



This is a digital copy of a book that was preserved for generations on library shelves before it was carefully scanned by Google as part of a project to make the world's books discoverable online.

It has survived long enough for the copyright to expire and the book to enter the public domain. A public domain book is one that was never subject to copyright or whose legal copyright term has expired. Whether a book is in the public domain may vary country to country. Public domain books are our gateways to the past, representing a wealth of history, culture and knowledge that's often difficult to discover.

Marks, notations and other marginalia present in the original volume will appear in this file - a reminder of this book's long journey from the publisher to a library and finally to you.

Usage guidelines

Google is proud to partner with libraries to digitize public domain materials and make them widely accessible. Public domain books belong to the public and we are merely their custodians. Nevertheless, this work is expensive, so in order to keep providing this resource, we have taken steps to prevent abuse by commercial parties, including placing technical restrictions on automated querying.

We also ask that you:

- + *Make non-commercial use of the files* We designed Google Book Search for use by individuals, and we request that you use these files for personal, non-commercial purposes.
- + *Refrain from automated querying* Do not send automated queries of any sort to Google's system: If you are conducting research on machine translation, optical character recognition or other areas where access to a large amount of text is helpful, please contact us. We encourage the use of public domain materials for these purposes and may be able to help.
- + *Maintain attribution* The Google "watermark" you see on each file is essential for informing people about this project and helping them find additional materials through Google Book Search. Please do not remove it.
- + *Keep it legal* Whatever your use, remember that you are responsible for ensuring that what you are doing is legal. Do not assume that just because we believe a book is in the public domain for users in the United States, that the work is also in the public domain for users in other countries. Whether a book is still in copyright varies from country to country, and we can't offer guidance on whether any specific use of any specific book is allowed. Please do not assume that a book's appearance in Google Book Search means it can be used in any manner anywhere in the world. Copyright infringement liability can be quite severe.

About Google Book Search

Google's mission is to organize the world's information and to make it universally accessible and useful. Google Book Search helps readers discover the world's books while helping authors and publishers reach new audiences. You can search through the full text of this book on the web at <http://books.google.com/>



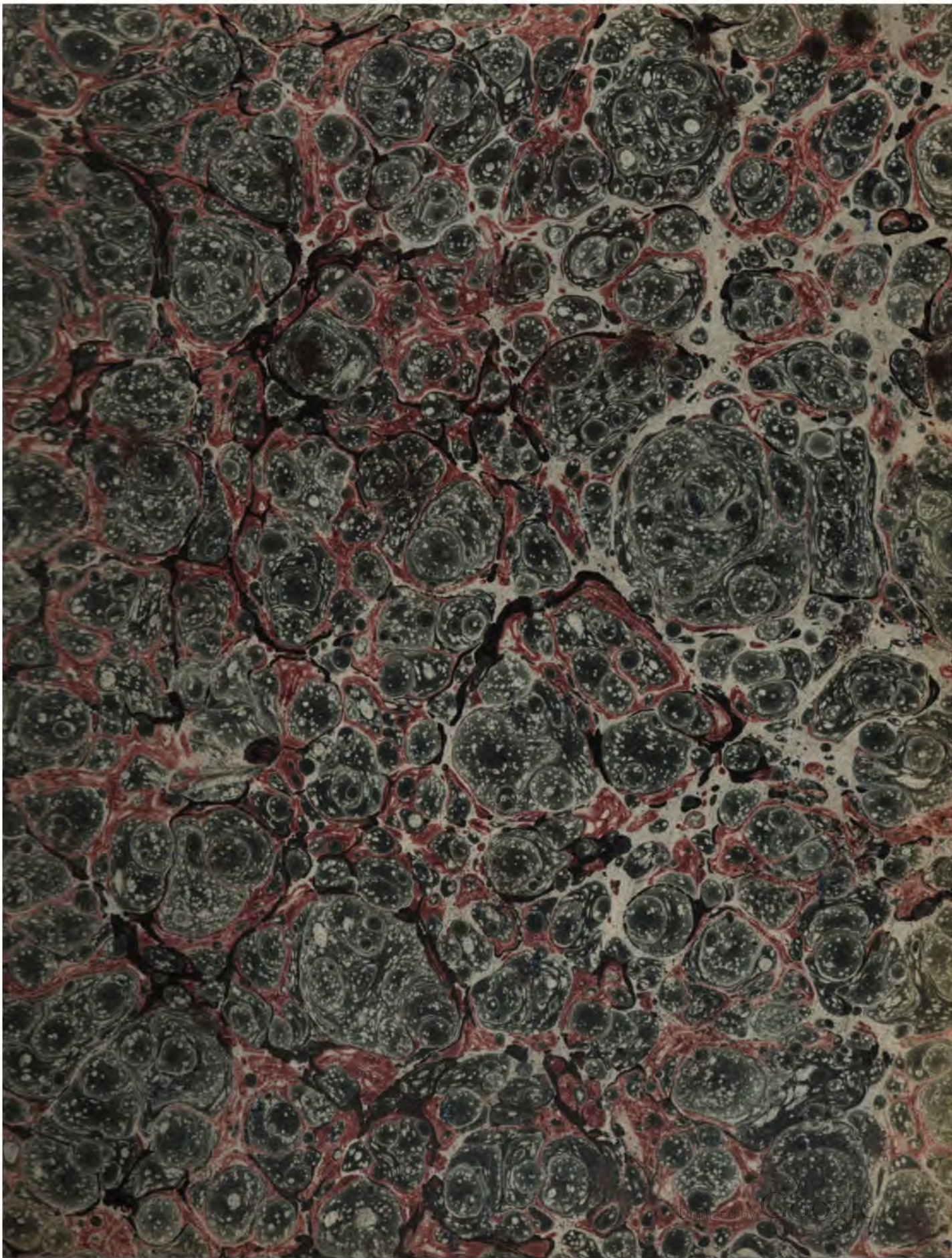

ENCYCLOPÆDIA BRITANNICA.

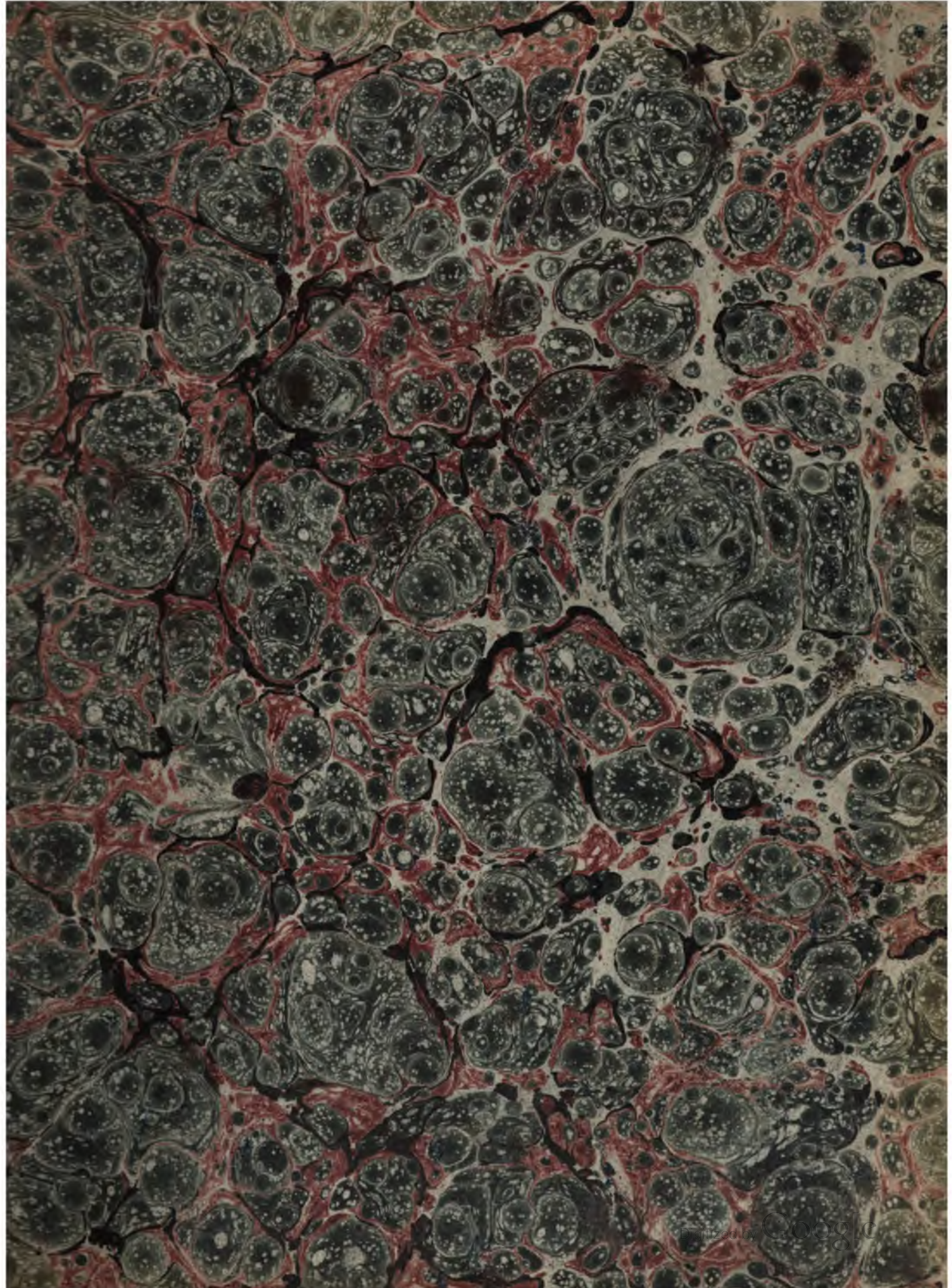

ENCYCLOPÆDIA BRITANNICA.

Encyclopædia Britannica:

OR, A

DICTIONARY

OF

ARTS, SCIENCES, AND MISCELLANEOUS
LITERATURE;

ENLARGED AND IMPROVED.

THE SIXTH EDITION.

Illustrated with nearly six hundred Engravings.

VOL. X.

INDOCTI DISCANT; AMENT MEMINISSE PERITI.

EDINBURGH:

PRINTED FOR ARCHIBALD CONSTABLE AND COMPANY;

AND HURST, ROBINSON, AND COMPANY, 90, CHEAPSIDE,

LONDON.

1823.

;

)

ENCYCLOPÆDIA BRITANNICA.

G O T

Gothofred,
Gotten-
burg.

GOTHOFRED, or GODFREY, DENIS or DIONYSIUS, an eminent civil lawyer, born of an illustrious house at Paris in 1549. Finding his country involved in the confusion of the leaguers, he accepted of a professor's chair at Geneva, until he was patronized and employed by Henry IV.; but being afterwards stripped of his employments as a Huguenot, he at length retired to Heidelberg, from whence no offers were able to detach him. He was, however, disappointed of his intention to end his days there; for the disturbances that broke out in the Palatinate obliged him, in 1621, to take refuge in Strasburg, where he died the following year. He wrote a great number of books; but his principal work is the *Corpus Juris Civilis, cum notis*.

GOTHOFRED, *Theodore*, son of the former, was born at Geneva in 1580. As soon as he had finished his studies, he went to Paris; where he conformed to the Romish religion, and applied with indefatigable industry to the study of history, that of France particularly, wherein he became very eminent, as appears by his works. In 1632, the king made him one of his historiographers, with a stipend of 3000 livres; and, in 1636, he was sent to Cologne, to assist at the treaty of peace negotiating there on the part of France, by the cardinal of Lyons. This treaty being removed to Munster, Gothofred was sent thither, where he drew up Memoirs on the subject; and continued in that city, in the king's service, to his death in 1649. His principal work is his "Account of the Ceremonial of the kings of France."

GOTTENBURG, or **GOTHEBURG**, a rich and strong town of West Gothland, in Sweden, with a good harbour, at the mouth of the river Gothebä; which is the best situated for foreign trade of any in Sweden, as it lies without the Sound. It occupies the site of an ancient town, named *Lodese*, which was built by Gustavus Vasa; and being endowed with considerable privileges, soon became the great emporium for the trade of the western provinces. Charles IX. when duke of Gothland, having in 1604 laid the foundations of a new town in the island of Hisingen, at no great distance from Lodese, called *Gotheborg* (since corrupted into *Gottenburg*), in honour of his duchy; upon his accession to the throne, he erected in his new town a trading company; drew thither many foreigners, particularly the Dutch, to whom he allowed an exemption from all duties of export and import during 20 years; a corps of English and

VOL. X. Part I.

G O T

Gotten-
burg,
Gottingen.

Scots troops under the command of William Stewart; and granted to the Calvinists established therein the free exercise of their religion, the first place in Sweden where this toleration was permitted. The town being in 1611 reduced to ashes by the Danes, was rebuilt in the reign of Gustavus Adolphus in its present situation, and obtained a confirmation of its ancient rights, with the grant of several additional privileges.—It is built in a very singular situation. At a small distance from the sea is a marshy plain, scarcely more than half a mile in breadth, watered by the rivers Gotha and Moldal, and almost entirely enclosed with high ridges of rocks, so bare and rugged, that they scarcely produce a single blade of grass, and exhibit as barren an appearance as the summits of the loftiest Alps. Gottenburg stands partly upon the ridges, and partly in the plain; and is divided from these different situations into the Upper and Lower Town. The latter is entirely level, intersected by several canals in the manner of the Dutch towns; and its houses are all constructed upon piles; the upper part hangs on the declivities; and rows of buildings rise one above the other like the seats of an amphitheatre. The whole is regularly fortified; and its circumference is near three miles, exclusive of the suburbs, called *Haga*, which lie toward the harbour. The streets are all uniformly straight: a few of the houses are of brick; but the generality are constructed with wood painted red. The harbour is formed by two chains of rocks, and is about a quarter of a mile in breadth. Its entrance is defended by the fort of New Elfsborg, which stands upon a small rocky island, and contains a garrison of 250 men. There is at Gottenburg a Royal Society of Sciences and Literature, upon the plan of that of Upsala.—Mr Coxe was informed by a merchant who had resided 22 years at Gottenburg, that, during that period, its population had increased considerably, and that it now contained about 30,000 inhabitants. This flourishing state is attributed to the extension of its commerce, particularly its East India Company, and the success of the herring-fishery. An English consul and several merchants of our nation reside at Gottenburg; and a chapel, with a regular chaplain, is appropriated to their use. E. Long. 11. 44. N. Lat. 57. 40.

GOTTINGEN, a considerable town of Lower Saxony in Germany, and in the duchy of Brunswick; formerly free and imperial, but afterwards subject to the elector of Hanover. Here his late majesty George II.

Göttingen
|
Goudt.

founded an university. It is seated on the river Leine, in E. Long. 9. 55. N. Lat. 51. 32.

GOTTORP, a town of the duchy of Sleswick, in Denmark, and capital of the duchy of Holstein Götterp, where the duke has a very fine palace.

GOUANIA, in *Botany*, a genus of plants belonging to the polygamia class. See *BOTANY Index*.

GOUDA, or **TURBOW**, a considerable town of South Holland, in the United Provinces, remarkable for its stately church. It is seated on the river Issel, in E. Long. 4. 36. N. Lat. 52. 1.

GOUDT, **HENRY**, usually called *Count Goudt*, was born of a noble family at Utrecht, in 1570; and was a knight of the Palatinate. Being passionately fond of the arts, particularly painting and engraving, and desirous of engaging in them, he applied himself diligently to drawing, and made a great proficiency therein. He went to Rome to examine the works of the great masters in that city. Here he contracted an intimacy with that excellent artist Adam Elsheimer; studied his manner of penciling, designing, and colouring; and made his works models for his own imitation. He pre-engaged all the pictures that his friend and favourite could finish, and even paid liberally for them before-hand; by which means he found himself in possession of a most desirable treasure. Those pictures which Goudt himself painted were neatly and delicately touched, in colour and pencil resembling Elsheimer, though they were in no degree equal to the paintings of that admirable master. On his return to his native country, a young woman, who was in love with him, and desirous of fixing his affections upon her, gave him in his drink a love philtre: which, however, terminated in a very melancholy manner, by depriving him totally of his senses; and in the dreadful state of idiotism he dragged on a miserable life to the age of 66, his death happening in 1636. It is remarkable, that though lost to every other subject, when painting was spoken of he would discourse upon it in a very rational manner.

Goudt practised engraving as well as painting, and made seven beautiful prints after the pictures of Elsheimer, which are well known to the curious, and are to be met with in most choice collections. He worked with the graver only, in a very neat style; and produced a most powerful effect, not by strengthening the strokes, according to the usual method, but by crossing them with additional strokes, equally neat, and that five or six times, one over another, in the deep shadows. Considering the precision with which he executed his engravings, the freedom of handling the graver which may be discovered in them is very astonishing. The woods and other parts of the fore-ground in that admirable print of the Ceres, are very finely expressed. The heads of the figures are correctly drawn, and the other extremities are managed in a judicious manner. The seven prints done by him from Elsheimer, mentioned above, are, 1. Ceres drinking from a pitcher. An old woman appears holding a candle at the door of the cottage, and a boy naked standing by her is laughing and pointing at the goddess; for which contempt he was metamorphosed by her into a frog. The powerful and striking effect of this engraving cannot be properly described. This print is distinguished also by the name of the *sorcery*. 2. The flight into Egypt: A

Goudt
|
Gourgues.

night-scene, in which the moon and stars are introduced with great success. 3. The angel with Tobit, who is drawing a fish by his side. The back-ground is a landscape; the weeds in the fore-ground, and the branches of the trees in front, as well as the foliage and weeds hanging from them, are beautifully expressed. 4. The angel with Tobit, crossing a stream of water: The back-ground, a landscape. 5. Baucis and Philemon entertaining Jupiter and Mercury. 6. A landscape, called the *Aurora*, representing the dawn of day. The effect is very beautiful. 7. The beheading of St John in prison, a very small upright oval print, which is by far the scarcest.

GOVERNMENT, in general, is the polity of a state, or an orderly power constituted for the public good.

Civil government was instituted for the preservation and advancement of men's civil interests, and for the better security of their lives, liberties, and properties. The use and necessity of government is such, that there never was an age or country without some sort of civil authority: but as men are seldom unanimous in the means of attaining their ends, so their differences in opinion in relation to government have produced a variety of forms of it. To enumerate them would be to recapitulate the history of the whole earth. But, according to Montesquieu, and most other writers, they may, in general, be reduced to one of these three kinds. 1. The republican. 2. The monarchical. 3. The despotic.—The first is that, where the people in a body, or only a part of the people, have the sovereign power; the second, where one alone governs, but by fixed and established laws; but in the despotic government, one person alone, without law and without rule, directs every thing by his own will and caprice. See the article *LAW*, N^o 1. 3.—10. On the subject of government at large, see Montesquieu's *L'Esprit des Loix*, l. 2. c. 1.; Locke, ii. 129, &c. quarto edition, 1768; Sidney on government; Sir Thomas Smith *de Repub. Angl.* and Acherly's *Britannic Constitution*.—As to Gothic government, its original and faults, &c. see Montesquieu's *L'Esprit des Loix*, l. 11. c. 8. See *FEOBAL System* in this work, and **GOVERNMENT** in the **SUPPLEMENT**.

GOVERNMENT is also a post or office, which gives a person the power or right to rule over a place, a city, or a province, either supremely or by deputation.

GOVERNMENT is likewise used for the city, country, or place to which the power of governing is extended.

GOUGE, an instrument used by divers artificers, being a sort of round hollow chisel; serving to cut holes, channels, grooves, &c. in wood, stone, &c.

GOULART, **SIMON**, a famous minister of Geneva, was born at Senlis in 1543; and was one of the most indefatigable writers of his time. He made considerable additions to the Catalogue of witnesses of the truth, composed by Illyricus; and acquired a great reputation by his works; the principal of which are, 1. A translation of Seneca. 2. A collection of memorable histories. 3. A translation of St Cyprian *De lapsis*. 4. Several devotional and moral treatises. He died at Geneva in 1628.

GOURD. See *CUCURBITA*, *BOTANY Index*.

GOURGUES, **DOMINIQUE**, an illustrious French patriot,

Gourgues
Gown.

Gown,
Gowran.

patriot, a private gentleman of Gascony. The Spaniards having inhumanly massacred a colony of Frenchmen who had settled in Florida, Gourgues took a severe revenge on them, an account of which is given under the article FLORIDA. On his return he was received with acclamations by his countrymen, but was forbidden to appear at court. Queen Elizabeth invited him to command an English fleet against the Spaniards in 1593; but he died at Tours in his way to England.

GOURNAY, a town of France, in the department of Lower Seine, celebrated for its butter-market. Population 2550. It is situated on the river Ept, in E. Long. 1. 47. N. Lat. 49. 29.

GOURNAY, *Mary de Jars de*, a lady celebrated for her learning, was the daughter of William de Jars, lord of Neufvi and Gournay. After the death of her father, she was patronised by Montaigne and Cardinal Richelieu. To the daughter of the former she dedicated her *Nesegay of Pindus*; and composed several other works, the most considerable of which is *Les Avis*. She died at Paris in 1685, aged 80. The critics are divided concerning the reputation of this lady: by some she is styled the *Syren of France*; others say her works should have been buried with her.

GOUT. See *MEDICINE Index*.

GOWER, JOHN, one of our most ancient English poets, was contemporary with Chaucer, and his intimate friend. Of what family, or in what country he was born, is uncertain. He studied the law, and was some time a member of the society of Lincoln's-inn, where his acquaintance with Chaucer began. Some have asserted that he was a judge; but this is by no means certain. In the first year of Henry IV. he became blind; a misfortune which he laments in one of his Latin poems. He died in the year 1402; and was buried in St Mary Overie, which church he had rebuilt chiefly at his own expence, so that he must have lived in affluent circumstances. His tomb was magnificently and curiously ornamented. It still remains, but hath been repaired in later times. From the collar of SS round the neck of his effigies, which lies upon the tomb, it is conjectured that he had been knighted. As to his character as a man, it is impossible, at this distance of time, to say any thing with certainty. With regard to his poetical talents, he was undoubtedly admired at the time when he wrote, though a modern reader may find it difficult to discover much harmony or genius in any of his compositions. He wrote, 1. *Speculum meditantis*, in French, in ten books. There are two copies of this in the Bodleian library. 2. *Vox clamantis*, in Latin verse, in seven books. Preserved also in the Bodleian library, and in that of All-Souls. It is a chronicle of the insurrection of the commons in the reign of Richard II. 3. *Confessio amantis*; printed at Westminster by Caxon in 1493. Lond. 1532, 1554. It is a sort of poetical system of morality, interspersed with a variety of moral tales. 4. *De rege Henrico IV*. Printed in Chaucer's works. There are likewise several historical tracts, in manuscript, written by our author, which are to be found in different libraries; also some short poems printed in Chaucer's works.

GOWN, *ROSK*, a long upper garment, worn by

lawyers, divines, and other graduates; who are hence called *men of the gown*, or *gownmen*.

The gown is an ample sort of garment, worn over the ordinary clothes, hanging down to the feet.—It is fashioned differently for ecclesiastics and for laymen.

At Rome they gave the name "virile gown," *toga virilis*, to a plain kind of gown which their youth assumed when arrived at puberty. This they particularly denominated *prætexta*. See *TOGA*, *PRÆTEXTA*, &c.

"The remarkable dress of our British ancestors (Mr Whitaker observes), which continued very nearly the same to the commencement of the last century among the natives of Ireland, and has actually descended to the present among the mountaineers of Scotland, and is therefore rendered very familiar to our ideas, carried in it an astonishing appearance to the Romans. And it seems to have been equally the dress of the men and women among the nobles of Britain. But in a few years after the erection of the Roman British towns in the north, and in the progress of refinement among them, this ancient habit began to be disesteemed by the chiefs of the cities, and looked upon as the badge of ancient barbarism. And the growing prejudices were soon so greatly improved, that within 20 years only after the construction of the towns, the British sagum was actually resigned, and the Roman *toga* or gown assumed by many of them.

"The gown, however, never became universal in Britain: and it seems to have been adopted only by the barons of the cities and the officers of the crown; and has therefore been transmitted to us as the robe of reverence, the ensign of literature, and the mantle of magistracy. The woollen and plaided garments of the chiefs having naturally superseded the leathern vestures of their clients, the former were still worn by the generality of the Britons; and they were retained by the gentlemen of the country, and by the commonalty both in country and city. That this was the case, appears evident from the correspondent conduct of the Gauls and Britons; who kept their *Virgata Sagula* to the last, and communicated them to the Franks and Saxons. The plaided drapery of the Britons still appeared general in the streets of Manchester; and must have formed a striking contrast to the gown of the chief, the dark mantle of Italy: and it and the ornamented buttons on the shoulder are preserved among us even to the present moment, in the parti-coloured clothing and the tasseled shoulder knots of our footmen."

In some universities physicians wear a scarlet gown. In the Sorbonne, the doctors were always in gowns and caps. Beadles, &c. wear gowns of two or more colours.

Among the French officers, &c. they distinguish those of the *short gown or robe*; which are such as have not been regularly examined. They have also barbers of the *short gown*, who are such as are obliged to practise in an inferior way to those of the long robe.

Gown is also taken in the general for civil magistrature, or the profession opposite to that of arms. In this sense it was that Cicero said *coheret armis togæ*.

GOWRAN, a borough town, in the county of Kilkenny and province of Leinster, Ireland. N. Lat.

Gowran
||
Graaf.

52. 34. W. Long. 7. 0. It is governed by a portrieve, recorder, and town clerk. Here are the ruins of an old church, also the handsome seat of the late Lord Clifden; and three miles beyond Gowran the ruins of Ballinabola castle.

GOYEN, JOHN VAN, painter of landscapes, cattle, and sea pieces, was born at Leyden in 1596; and was for some time instructed by Isaac Nicholai, who was reputed a good painter; but afterwards he became the disciple of Esaias Vandervelde, the most celebrated landscape painter of his time. Van Goyen very soon rose into general esteem; and his works are more universally spread through all Europe than the works of any other master, for he possessed an uncommon readiness of hand and freedom of pencil. It was his constant pleasure and practice to sketch the views of villages and towns situated on the banks of rivers or canals; of the sea-ports in the Low Countries; and sometimes of inland villages, where the scenes around them appeared to him pleasing or picturesque. Those he afterwards used as subjects for his future landscapes; enriching them with cattle, boats, and figures in character, just as the liveliness of his imagination directed. He understood perspective extremely well, and also the principles of the chiaro-scuro; which branches of knowledge enabled him to give his pictures a strong and agreeable effect. He died in 1656, aged 60.—His usual subjects were sea-pieces, or landscapes with views of rivers, enlivened with figures of peasants either ferrying over cattle, drawing their nets in still water, or going to or returning from market. Sometimes he represented huts of boors on the banks of rivers, with overhanging trees, and a beautiful reflection of their branches from the transparent surface of the waters. These were the subjects of his best time, which he generally marked with his name and the year; and the high finished pictures of Van Goyen will be for ever estimable. But as he painted abundance of pictures, some are slight, some too yellow, and some negligently finished; though all of them have merit, being marked with a free, expeditious, and easy pencil, and a light touch. His pictures frequently have a grayish cast; which did not arise from any mismanagement of the tints, or any want of skill in laying on the colours; but was occasioned by his using a colour called *Haerlem blue*, much approved of at that time, though now entirely disused, because the artists found it apt to fade into that grayish tint; and it hath also rendered the pictures of this master exceedingly difficult to be cleaned without injuring the finer touches of the finishing. His best works are valued so highly in most parts of Europe, and especially in the Low Countries, that they deservedly afford large prices, being ranked in Holland with the pictures of Teniers; and at this time are not easily procured, particularly if they are undamaged, though his slighter performances are sufficiently common.

GRAAF, REGNIER DE, a celebrated physician, born at Schoonhaven, in Holland, in 1641. He studied physic in Prussia. He was educated in Leyden, where he acquired great honour by publishing a treatise *De Succo Pancreatico*. He also published three pieces upon the organs of generation, both male and female; upon which subject he had a controversy with Swammerdam. He died young, in 1673; and his works,

with his life prefixed, were published at Leyden in 1677, in 8vo.

GRABE, JOHN ERNEST, a very learned writer in the beginning of the 18th century, a native of Konigsberg, in Prussia. He was educated in the Lutheran religion; but the reading of the fathers led him into doubts. He presented to the electoral consistory at Sambia in Prussia a memorial containing his doubts. The elector gave orders to three eminent divines to answer them. Their answers shook him a little in his resolution of embracing the Roman Catholic religion; and one of them, Spener, advised him to go to England. He went; and King William gave him a pension, which was continued by Queen Anne. He was ordained a priest of the church of England, and honoured with the degree of doctor of divinity by the university of Oxford; upon which occasion Dr George Smalridge pronounced two Latin orations, which were afterwards printed. He wrote, 1. *Spicilegium S. S. Patrum, ut et Hereticorum sæculi post Christum natum*, 8vo. 2. An edition of the Septuagint, from the Alexandrian manuscript in St James's library. 3. Notes on Justin, &c.; and other works, which are esteemed by the learned.

GRACCHUS, TIBERIUS, elected tribune of the Roman people, demanded in the senate, in their name, the execution of the Agrarian law; by which all persons possessing above 200 acres of land were to be deprived of the surplus, for the benefit of the poor citizens, amongst whom an equal distribution of them was to be made. Having carried his plan into execution by violent measures, he fell a victim to his zeal, being assassinated by his own party, 133 B. C. Caius his brother, pursuing the same steps, was killed by the consul Opimius, 121 B. C. See (history of) ROME.

GRACE, among divines, is taken, 1. For the free love and favour of God, which is the spring and source of all the benefits we receive from him. 2. For the work of the Spirit renewing the soul after the image of God; and continually guiding and strengthening the believer to obey his will, to resist and mortify sin, and overcome it.

GRACE is also used, in a peculiar sense, for a short prayer said before and after meat.

The proofs of the moral obligation of this ceremony, drawn from different passages of the New Testament, are so well known, that it is needless to insist on them here. Some others, drawn from the practice of different nations, and of very remote antiquity, may not be disagreeable to our readers.

1. Athenæus tells us, in his *Deipnosoph.* lib. ii. that in the famous regulation made by Amphictyon king of Athens with respect to the use of wine, both in sacrifices and at home, he required that the name of *Jupiter the Sustainer* should be decently and reverently pronounced. The same writer, in lib. iv. p. 149. quotes Hermeias, an author extant in his time, who informs us of a people in Egypt, inhabitants of the city of Naucratis, whose custom it was on certain occasions, after they had placed themselves in the usual posture of eating at the table, to rise again and kneel; when the priest or precentor of the solemnity began to chant a grace, according to a stated form amongst them; and when that was over, they joined in the meal in a solemn sacrificial manner. Heliodorus has a

passage

Grace. passage in his *Ethiopics* to the same purpose, that it was the custom of the Egyptian philosophers to pour out libations and put up ejaculations before they sat down to meals. Porphyry, in his treatise *De abstin.* lib. iv. p. 408. gives a great character of the Samnean gymnosophists in Egypt for the strictness of their life: as one article in their favour, he observes, that at the sounding of a bell before their meals, which consisted only of rice, bread, fruits, and herbs, they went to prayers; which being ended, and not before, the bell sounded again, and they sat down to eating. In general this was a religious usage or rite among the ancient Greeks; and derived from yet older ages, if Clement of Alexandria rightly informs us. He mentions, that these people when they met together to refresh themselves with the juice of the grape, sung a piece of music, in imitation of the Hebrew psalms, which they called a *scholion*. Livy, lib. xxxix. speaks of it as a settled custom among the old Romans, that they offered sacrifice and prayer to the gods at their meals and computations. But one of the fullest testimonies to our purpose is given by Quintilian, *Declam.* 301. *Adisti mensam*, says he, *ad quam cum venire cepimus, Deos invocamus*; "We approached the table (at supper together), and then invoked the gods."

The Jesuit Trigautius, in his very elegant and instructive narrative of the Christian expedition of their missionaries into China, book i. p. 69. gives this account of the people there in the particular now under consideration. "Before they place themselves for partaking of an entertainment, the person who makes it sets a vessel, either of gold, or silver, or marble, or some such valuable material, in a charger full of wine, which he holds with both his hands, and then makes a low bow to the person of chief quality or character at the table. Then from the hall or dining-room, he goes into the porch or entry, where he again makes a very low bow, and turning his face to the south, pours out this wine upon the ground as a thankful oblation to the Lord of heaven. After this, repeating his reverential obeisance, he returns into the hall." &c.

The Turks pray for a blessing on their meat; and many more instances might be produced of infidels who have constantly observed the like custom in some way or other.

2. The fact, therefore, with respect to the heathen world, being thus evident, we proceed to the sentiments and behaviour of the Jews in this particular. Their celebrated historian Josephus, giving a detail of the rites and customs of the Essenes, who were confessedly the strictest and most pious professors of the Jewish religion, has this remarkable passage to the present purpose: "The priest," says he, "begs a blessing before they presume to take any nourishment; and it is looked upon as a great sin to take or taste before." Then follows the thanksgiving before meat: and "when the meal," proceeds he, "is over, the priest prays again; and the company with him bless and praise God as their preserver, and the donor of their life and nourishment."

Philo, in his book *De vita contemplativa*, gives an account of a body of men and women stricter than even the Essenes themselves. He distinguishes them by

Grace. no particular name, though his relation is very accurate and circumstantial; namely, that on certain special occasions, before "they took their meals, they placed themselves in a proper decent order; when, lifting up their hands and eyes to heaven, they prayed to God that he would be pleased to be propitious to them in the use of those his good creatures."

From the Hebrew ritual it appears, that the Jews had their hymns and psalms of thanksgiving, not only after eating their passover, but on a variety of other occasions, at and after meals, and even between their several courses and dishes; as when the best of their wine was brought upon the table, or their aromatic confections, or the fruit of the garden, &c. On the day of the passover was sung Psalm cxiv. "When Israel came out of Egypt," &c.

Aristæus has a passage full on the present subject. "Moses," says he, "commands that when the Jews are going to eat or drink, the company should immediately join in sacrifice or prayer." Where Rabbi Eleazar (upon that author) met with this sentence, was being controverted. But supposing it not be found *in scriptis*, it is sufficient for us to know that the Jews did constantly practise this custom, upon the foundation of an ancient and general tradition and usage. That the prophet Daniel gave thanks before meat, is evident from the Apocryphal book concerning Bel and the Dragon, where, ver. 38, 39, we find, that "Daniel said, Thou hast remembered me, O God! neither hast thou forsaken them who seek thee and love thee. So Daniel arose, and did eat." Of this text Prudentia takes notice in Cathemirin, hymn iv.

*His sumptis Danielis excitavit
In cœlum faciem, cibeque fortis,
Amen reddidit, allelujah dixit.
The much-belov'd took the repast,
And up to heav'n his eyes he cast;
By which refresh'd he sung aloud,
Amen, and allelujah to his God.*

Where, by the way, it may be observed, that the poet is a little mistaken in making the prophet give thanks after meat; whereas, according to the text, he did it before.

GRACE, or *Gracefulness*, in the human character; an agreeable attribute, inseparable from motion as opposed to rest, and as comprehending speech, looks, gesture, and loco-motion.

As some motions are homely, the opposite to graceful; it is to be inquired, With what motions is this attribute connected? No man appears graceful in a mask; and therefore, laying aside the expressions of the countenance, the other motions may be genteel, may be elegant, but of themselves never are graceful. A motion adjusted in the most perfect manner to answer its end, is elegant; but still somewhat more is required to complete our idea of grace or gracefulness.

What this unknown *more* may be; is the nice point. One thing is clear from what is said, that this *more* must arise from the expressions of the countenance: and from what expressions so naturally as from those which indicate mental qualities, such as sweetness, benevolence, elevation, dignity? This promises to be a fair analysis: because of all objects mental qualities affect us the most; and

Grace,
Graces.

and the impression made by graceful appearance upon every spectator of taste, is too deep for any cause purely corporeal.

The next step is, to examine what are the mental qualities, that in conjunction with elegance of motion, produce a graceful appearance. Sweetness, cheerfulness, affability, are not separately sufficient, nor even in conjunction. Dignity alone, with elegant motion, produces a graceful appearance; but still more graceful with the aid of other qualities, those especially that are the most exalted. See **DIGNITY**.

But this is not all. The most exalted virtues may be the lot of a person whose countenance has little expression: such a person cannot be graceful. Therefore to produce this appearance, we must add another circumstance, viz. an expressive countenance, displaying to every spectator of taste, with life and energy, every thing that passes in the mind.

Collecting these circumstances together, grace may be defined, "that agreeable appearance which arises from elegance of motion and from a countenance expressive of dignity." Expressions of other mental qualities are not essential to that appearance, but they heighten it greatly.

Of all external objects, a graceful person is the most agreeable.

Dancing affords great opportunity for displaying grace, and haranguing still more. See **DANCING**, **DECLAMATION**, and **ORATORY**.

But in vain will a person attempt to be graceful who is deficient in amiable qualities. A man, it is true, may form an idea of qualities he is destitute of; and, by means of that idea, may endeavour to express these qualities by looks and gestures: but such studied expression will be too faint and obscure to be graceful.

Act of GRACE, the appellation given to the act of parliament 1696, c. 32. which allows prisoners for civil debts to be set at liberty, upon making oath that they have not wherewithal to support themselves in prison, unless they are alimeted by the creditors on whose diligences they were imprisoned, within ten days after intimation made for that purpose.

Days of GRACE, three days immediately following the term of payment of a bill, within which the creditor must protest it if payment is not obtained, in order to intitle him to recourse against the drawer.

GRACE is also a title of dignity given to dukes, archbishops, and in Germany to barons and other inferior princes.

GRACES, **GRATIAE**, *Charities*, in the heathen theology, were fabulous deities, three in number, who attended on Venus. Their names are, *Aglais*, *Thais*, and *Euphroayne*; i. e. shining, flourishing, and gay; or, according to some authors, *Pasithea*, *Euphrosyne*, and *Ægiale*. They were supposed by some to be the daughters of Jupiter and Eurynome the daughter of Oceanus; and by others, to be the daughters of Bacchus and Venus.

Some will have the Graces to have been four; and make them the same with the *Hora* "hours", or rather with the four seasons of the year. A marble in the king of Prussia's cabinet represents the three Graces in the usual manner, with a fourth seated and covered with a large veil, with the words underneath, *Ad Sorores III*. But this groupe we may understand to be the

three Graces, and Venus, who was their sister, as being daughter of Jupiter and Dione.

The Graces are always supposed to have hold of each other's hands, and never parted. They were painted naked, to show that the Graces borrow nothing from art, and that they have no other beauties than what are natural.

Yet in the first ages they were not represented naked, as appears from Pausanias, lib. vi. and lib. ix. who describes their temple and statues. They were of wood, all but their head, feet, and hands, which were white marble. Their robe or gown was gilt: one of them held in her hand a rose, another a dye, and the third a sprig of myrtle.

GRACILIS, a muscle of the leg, thus called from its slender shape. See **ANATOMY**, *Table of the Muscles*.

GRACULA, the **GRACKLE**, a genus of birds belonging to the order of picæ. See **ORNITHOLOGY Index**.

GRACULUS. See **CORVUS**, **ORNITHOLOGY Index**.

GRADATION, in general, the ascending step by step, or in a regular and uniform manner.

GRADATION, in *Logic*, a form of reasoning, otherwise called **SORITES**.

GRADATION, in *Painting*, a gradual and insensible change of colour, by the diminution of the tints and shades.

GRADATION, in *Rhetoric*, the same with **CLIMAX**.

GRADISKA, a strong town of Hungary in Sclavonia, on the frontiers of Croatia, taken by the Turks in 1691. It is seated on the river Save, in E. Long. 17. 55. N. Lat. 45. 38.

GRADISKA, a strong town of Italy, in a small island of the same name on the frontiers of Friuli, in E. Long. 13. 37. N. Lat. 46. 6. It is subject to the house of Austria.

GRADO, a strong town of Italy, in a small island of the same name, on the coast of Friuli, and in the Austrian territory. E. Long. 13. 27. N. Lat. 45. 46.

GRADUATE, a person who has taken a degree in the university. See **DEGREE**.

GRÆVIUS, **JOHN GEORGE**, one of the most learned writers in the 17th century. In the 24th year of his age, the elector of Brandenburg made him professor at *Doisbourg*. In 1658, he was invited to *Deventer* to succeed his former master *Gronovius*. In 1661, he was appointed professor of eloquence at *Utrecht*; and 12 years after he had the professorship of politics and history conferred on him. He fixed his thoughts here, and refused several advantageous offers. He had, however, the satisfaction to be sought after by divers princes, and to see several of them come from Germany, to study under him. He died in 1703, aged 71. His *Theaurus antiquitatum et historiarum Ratiæ*, &c. and other works, are well known.

GRAFTING, or **ENGRAFTING**, in *Gardening*, is the taking a shoot from one tree, and inserting it into another, in such a manner that both may unite closely and become one tree. By the ancient writers on husbandry and gardening, this operation is called *incision*, to distinguish it from inoculation or budding, which they call *inserere oculos*.

Grafting has been practised from the most remote antiquity;

Graces
Grafting.

Coasting,
Graham.

Graham
|
Graham.

antiquity; but its origin and invention is differently related by naturalists. Theophrastus tells us, that a bird having swallowed a fruit whole, cast it forth into a cleft or cavity of a rotten tree; where mixing with some of the petrified parts of the wood, and being washed with the rains, it budded, and produced within this tree another tree of a different kind. This led the husbandmen to certain reflections, from which soon afterwards arose the art of engraving. For the different methods of performing this operation, see GARDENING Index.

GRAHAM, JAMES, Marquis of Montrose, was comparable to the greatest heroes of antiquity. He undertook, against almost every obstacle that could terrify a less enterprising genius, to reduce the kingdom of Scotland to the obedience of the king; and his success corresponded to the greatness of the undertaking. By valour, he in a few months, almost effected his design; but, for want of supplies, was forced to abandon his conquests. After the death of Charles I. he made a second attempt, with a few men, but was immediately defeated by a numerous army. As he was leaving the kingdom in disguise, he was betrayed into the hands of his enemy, by the lord Aston, his intimate friend. He was carried to his execution with every circumstance of indignity that wanton cruelty could invent; and hanged upon a gibbet 30 feet high, with the book of his exploits appended to his neck. He bore this reverse of fortune with his usual greatness of mind, and expressed a just scorn at the rage and the insult of his enemies. We meet with many instances of valour in this active reign; but Montrose is the only instance of heroism. He was executed May 21. 1650. See BRITAIN, N^o 137, 138, 143, 165.

GRAHAM, Sir Richard, Lord Viscount Preston, eldest son of Sir George Graham of Netherby, in Cumberland, Bart. was born in 1648. He was sent ambassador by Charles II. to Louis XIV. and was master of the wardrobe and secretary of state under James II. But when the revolution took place, he was tried and condemned, on an accusation of attempting the restoration of that prince; though he obtained a pardon by the queen's intercession. He spent the remainder of his days in retirement, and published an elegant translation of "Boethius on the consolation of philosophy." He died in 1695.

GRAHAM, George, clock and watch-maker, the most ingenious and accurate artist in his time, was born in 1675. After his apprenticeship, Mr Tompion received him into his family, purely on account of his merit; and treated him with a kind of parental affection as long as he lived. Besides his universally acknowledged skill in his profession, he was a complete mechanic and astronomer; the great mural arch in the observatory at Greenwich was made for Dr Halley, under his immediate inspection, and divided by his own hand: and from this incomparable original, the best foreign instruments of the kind are copied made by English artists. The sector by which Dr Bradley first discovered two new motions in the fixed stars, was of his invention and fabric: and when the French academicians were sent to the north to ascertain the figure of the earth, Mr Graham was thought the fittest person in Europe to supply them with instruments; those

who went to the north were not so well furnished. He was for many years a member of the Royal Society, to which he communicated several ingenious and important discoveries; and regarded the advancement of science more than the accumulation of wealth. He died in 1751.

GRAHAM'S Dyke. See ANTONINUS'S Wall.

GRAIN, corn of all sorts, as barley, oats, rye, &c. See CORN, WHEAT, &c.

GRAIN is also the name of a small weight, the twentieth part of a scruple in apothecaries weight, and the twenty-fourth of a pennyweight Troy.

A grain-weight of gold-bullion is worth two-pence, and that of silver but half a farthing.

GRAIN also denotes the component particles of stones and metals, the veins of wood, &c. Hence cross-grained, or against the grain, means contrary to the fibres of wood, &c.

GRALLÆ, in Ornithology, is an order of birds analogous to the *bruta* in the class of *mammalia* in the Linnæan system. See ORNITHOLOGY.

GRAMINA, GRASSES; one of the seven tribes or natural families, into which all vegetables are distributed by Linnæus in his *Philosophia Botanica*. They are defined to be plants which have very simple leaves, a jointed stem, a husky calyx termed *gluma*, and a single seed. This description includes the several sorts of corn as well as grasses. In Tournefort they constitute a part of the fifteenth class, termed *apetalæ*; and in Linnæus's sexual method, they are mostly contained in the second order of the third class, called *triandria digynia*.

This numerous and natural family of the grasses has engaged the attention and researches of several eminent botanists. The principal of these are, Ray, Monti, Micheli, and Linnæus.

M. Monti, in his *Catalogus stirpium agri Bononiensis gramina ac hujus modi affinia complectens*, printed at Bononia in 1719, divides the grasses from the disposition of their flowers, as Theophrastus and Ray have divided them before him, into three sections or orders. — These are, 1. Grasses having flowers collected in a spike. 2. Grasses having their flowers collected in a panicle or loose spike. 3. Plants that in their habit and external appearance are allied to the grasses.

This class would have been natural if the author had not improperly introduced sweet-rush, juncus, and arrow-headed grass, into the third section. Monti enumerates about 306 species of the grasses, which he reduces under Tournefort's genera; to these he has added three new genera.

Scheuchzer in his *Aristographia*, published likewise in 1719, divides the grasses, as Monti, from the disposition of their flowers, into the five following sections: 1. Grasses with flowers in a spike, as phalaris, anthoxanthum, and frumentum. 2. Irregular grasses, as schœnanthus, and cornucopia. 3. Grasses with flowers growing in a simple panicle or loose spike, as reed and millet. 4. Grasses with flowers growing in a compound panicle, or diffused spike, as oats and poa. 5. Plants by their habit nearly allied to the grasses, as cyprus-grass, scirpus, linagrostis, rush, and scheuchzeria.

Scheuchzer has enumerated about four hundred species, which he describes with amazing exactness.

Gramina,
Grammar.

Micheli has divided the grasses into six sections, which contain in all 44 genera, and are arranged from the situation and number of the flowers.

GRAMINA, the name of the fourth order in Linnæus's Fragments of a Natural Method, consisting of the numerous and natural family of the grasses, viz. agrostis, aira, alopecurus or fox-tail grass, anthoxanthum or vernal grass, aristida, arundo or reed, avena or oats, bobartia, briza, bromus, cinna, cornucopiæ or horn of plenty grass, cynosurus, dactylis, elymus, festuca or fescue-grass, hordeum or barley, lagurus or hare's-tail

grass, lolium or darnel, lygeum or hooded matweed, melica, milium or millet, nardus, oryza or rice, panicum or panic-grass, paspalum, phalaris or canary-grass, phleum, poa, saccharum or sugar-cane, secale or rye, stipa or winged spike-grass, triticum or wheat, uniola or seaside oats of Carolina, coix or Job's tears, olyra, pharus, tripsacum, zea, Indian Turkey wheat or Indian corn, zizania, segilops or wild fescue-grass, andropogon, ap-luda, cenchrus, holcus or Indian millet, ischæmum. See BOTANY.

Gramin
Gramin

GRAMMAR.

Definition.

1. **G**RAMMAR is the art of speaking or of writing any language with propriety; and the purpose of language is to communicate our thoughts.

2. Grammar, considered as an art, necessarily supposes the previous existence of language; and as its design is to teach any language to those who are ignorant of it, it must be adapted to the genius of that particular language of which it treats. A just method of grammar, therefore, without attempting any alterations in a language already introduced, furnishes certain observations called *rules*, to which the methods of speaking used in that language may be reduced; and this collection of rules is called the *grammar* of that particular language. For the greater distinctness with regard to these rules, grammarians have usually divided this subject into four distinct heads, viz. **ORTHOGRAPHY**, or the art of combining letters into syllables, and syllables into words; **ETYMOLOGY**, or the art of deduc-

Grammar
particular,

ing one word from another, and the various modifications by which the sense of any one word can be diversified consistently with its original meaning or its relation to the theme whence it is derived; **SYNTAX**, or what relates to the construction or due disposition of the words of a language into sentences or phrases; and **PROSODY**, or that which treats of the quantities and accents of syllables, and the art of making verses.

3. But grammar, considered as a science, views language only as it is significant of thought. Neglecting particular and arbitrary modifications introduced for the sake of beauty or elegance, it examines the analogy and relation between words and ideas; distinguishes between those particulars which are essential to language and those which are only accidental; and thus furnishes a certain standard, by which different languages may be compared, and their several excellencies or defects pointed out. This is what is called **PHILOSOPHIC** or

UNIVERSAL GRAMMAR.

4. **T**HE origin of language is a subject which has employed much learned investigation, and about which there is still a diversity of opinion. The design of speech is to communicate to others the thoughts and perceptions of the mind of the speaker: but it is obvious, that between an internal idea and any external sound there is no natural relation; that the word *fire*, for instance, might have denominated the substance which we call *ice*, and that the word *ice* might have signified *fire*. Some of the most acute feelings of man, as well as of every other animal, are indeed expressed by simple inarticulate sounds, which as they tend to the preservation of the individual or the continuance of the species, and invariably indicate either pain or pleasure, are universally understood: but these inarticulate and significant sounds are very few in number; and if they can with any propriety be said to constitute a natural and universal language, it is a language of which man as a mere sensitive being partakes in common with the other animals.

The design
of speech.

5. Man is endowed not only with *sensation*, but also with the faculty of *reasoning*; and simple inarticulate sounds are insufficient for expressing all the various modifications of thought, for communicating to others a chain of argumentation, or even for distinguishing be-

Language
consists of
words signi-
ficant of
ideas.

tween the different sensations either of pain or of pleasure: a man scorched with fire or unexpectedly plunged among ice, might utter the cry naturally indicative of sudden and violent pain; the cry would be the same, or nearly the same, but the sensations of cold and heat are widely different. *Articulation*, by which those simple sounds are modified, and a particular meaning fixed to each modification, is therefore absolutely necessary to such a being as man, and forms the language which distinguishes him from all other animals, and enables him to communicate with facility all that diversity of ideas with which his mind is stored, to make known his particular wants, and to distinguish with accuracy all his various sensations. Those sounds thus modified are called **WORDS**; and as words have confessedly no natural relation to the ideas and perceptions of which they are significant, the use of them must either have been the result of human sagacity, or have been suggested to the first man by the Author of nature.

6. Whether language be of divine or human origin, is a question upon which, though it might perhaps be soon resolved, it is not necessary here to enter. Upon either supposition, the first language, compared with those which succeeded it, or even with itself as afterwards enlarged, must have been extremely rude and

narrow.

E,

ASSES, WITH THEIR SUBDIVISIONS.

There is a certain affection of nouns denoting the sex of those substances of which they are the names. For as in nature every object is either male, or female, or neither the one nor the other, grammarians, following this idea, have divided the names of beings into three classes. Those which denote males, are said to be of the *MASCULINE* gender; those that denote females, of the *FEMININE* gender; and those which denote neither the one nor the other, of the *NEUTER* gender. The English is the only language of which the nouns are, with respect to sex, an exact copy of nature. There is no object in nature single and alone, and as by far the greater part of nouns are the names of whole classes of objects, it is necessary that every such noun ought to have some variation, to denote whether it is one individual of the class which it

Division of Words.

narrow. If it was of *human* contrivance, this will be readily granted; for what art was ever invented and brought to a state of perfection by illiterate savages? If it was taught by GOD, which is at least the more probable supposition, we cannot imagine that it would be more comprehensive than the ideas of those for whose immediate use it was intended; that the first men should have been taught to express pains or pleasures which they never felt, or to utter sounds that should be afterwards significant of ideas which at the time of utterance had not occurred to the mind of the speaker: man, taught the elements of language, would be able himself to improve and enlarge it as his future occasions should require.

6
Origin of ideas.

7. As all language is composed of significant words variously combined, a knowledge of them is necessary previous to our acquiring an adequate idea of language as constructed into sentences and phrases. But as it is by words that we express the various ideas which occur to the mind, it is necessary to examine how ideas themselves are suggested; before we can ascertain the various classes into which words may be distributed. It is the province of *logic* to trace our ideas from their origin, as well as to teach the art of reasoning: but it is necessary at present to observe, that our earliest ideas are all ideas of sensation, excited by the impressions that are made upon our organs of sense by the various objects with which we are surrounded. Let us therefore suppose a reasonable being, devoid of every possible prepossession, placed upon this globe; and it is obvious, that his attention would in the first place be directed to the various objects which he saw existing around him. These he would naturally endeavour to distinguish from one another; and if he were either learning or inventing a language, his first effort would be to give them *names*, by means of which the ideas of them might be recalled when the objects themselves should be absent. This is one copious source of words; and forms a natural class which must be common to every language, and which is distinguished by the name of NOUNS; and as these nouns are the names of the several substances which exist, they have likewise been called SUBSTANTIVES.

7
Of nouns.

8. It would likewise be early discovered, that every one of these substances was endowed with certain qualities or attributes; to express which another class of words would be requisite, since it is only by their qualities that substances themselves can attract our attention. Thus, *to be weighty*, is a quality of matter; *to think*, is an attribute of man. Therefore in every language words have been invented to express the known qualities or attributes of the several objects which exist.

8
Of attributes.

These may all be comprehended under the general denomination of ATTRIBUTIVES.

Division of Words.

9. NOUNS and ATTRIBUTIVES must comprehend all that is *essential* to language (A): for every thing which exists, or of which we can form an idea, must be either a *substance* or the *attribute* of some substance; and therefore those two classes which denominate substances and attributes, must comprehend all the words that are *necessary* to communicate to the bearer the ideas which are present to the mind of the speaker. If any other words occur, they can only have been invented for the sake of dispatch, or introduced for the purposes of ease and ornament, to avoid tedious circumlocutions or disagreeable tautologies. There are indeed grammarians of great name, who have considered as essential to language an order of words, of which the use is to connect the nouns and attributes, and which are said to have *no signification of themselves*, but to become *significant by relation*. Hence all words which can possibly be invented are by these men divided into two general classes: those which are SIGNIFICANT OF THEMSELVES, and those which are NOT. Words significant of themselves are either expressive of the names of substances, and therefore called SUBSTANTIVES; or of attributes, and therefore called ATTRIBUTIVES. Words which are not significant of themselves, must acquire a meaning either as defining or connecting others; and are therefore arranged under the two classes of DEFINITIVES and CONNECTIVES.

9
Of definitives and connectives.

10. That in any language there can be words which of themselves have *no signification*, is a supposition which a man free from prejudice will not readily admit; for to what purpose should they have been invented? as they are significant of no ideas, they cannot facilitate the communication of thought, and must therefore be only an incumbrance to the language in which they are found. But in answer to this it has been said, that these words, though devoid of signification themselves, acquire a sort of meaning when joined with others, and that they are as necessary to the structure of a sentence as cement is to the structure of an edifice: for as *stones* cannot be arranged into a regular building without a *cement* to bind and connect them, so the original words significant of *substances* and *attributes*, cannot be made to express all the variety of our ideas without being *defined* and *connected* by those words which of themselves signify *nothing*.—It is wonderful, that he who first suggested this simile did not perceive that it tends to overthrow the doctrine which it is meant to illustrate: for surely the *cement* is as much the *matter* of the building as the *stones* themselves; it is equally solid and equally extended. By being united with

(A) This is the doctrine of many writers on the theory of language, for whose judgment we have the highest respect: yet it is not easy to conceive mankind so far advanced in the art of abstraction as to view *attributes* by themselves independent of particular *substances*, and to give one general name to each attribute wheresoever it may be found, without having at the same time words expressive of *affirmation*. We never talk of any *attribute*, a colour for instance, without *affirming* something concerning it; as, either that it is *bright* or *faint*, or that it is the colour of some *substance*. It will be seen afterwards, that to denote *affirmation* is the proper office of what is called the substantive *verb*: as, "Milk is white." That *verb* therefore appears to be as necessary to the communication of thought as any species of words whatever; and if we must range words under a few general classes, we should be inclined to say, that *nouns*, *attributes*, and *affirmatives*, comprehend all that is essential to language.

Division of Words. with the stones, it neither acquires nor loses any one of the qualities *essential to matter*; it neither communicates its own softness, nor acquires their hardness. By this mode of reasoning therefore it would appear, that the words called *definitives* and *connectives*, so far from having of themselves *no signification*, are equally essential to language, and equally significant with those which are denominated *substantives* and *attributives*; and upon investigation it will be found that this is the truth. For whatever is meant by the *definition* or *connection* of the words which *all men* confess to be significant, *that meaning* must be the sense of the words of which the purpose is to define and connect; and as there can be *no meaning* where there are no *ideas*, every one of these *definitives* and *connectives* must be significant of *some idea*, although it may not be always easy or even possible to express that idea by another word.

11. These different modes of dividing the parts of speech we have just mentioned, because they have been largely treated of by grammarians of high fame. But it does not appear to us, that any man can feel himself much the wiser for having learned that all words are either **SUBSTANTIVES** or **ATTRIBUTIVES**, **DEFINITIVES** or **CONNECTIVES**. The division of words into those which are **SIGNIFICANT OF THEMSELVES**, and those which are **SIGNIFICANT BY RELATION**, is absolute nonsense, and has been productive of much error and much mystery in some of the most celebrated treatises on grammar. It is indeed probable, that any attempt to establish a different classification of the parts of speech from that which is commonly received, will be found of little utility either in *practice* or in *speculation*. As far as the *former* is concerned, the vulgar division seems sufficiently commodious; for every man who knows any thing, knows when he uses a *noun* and when a *verb*. With respect to the *latter*, not to mention that all the grammarians from **ARISTOTLE** to **HORNE TOOKE**, have differed on the subject, it should seem to be of more importance, after having ascertained with precision the nature of each species of words, to determine in what circumstances they *differ* than in what they *agree*.

12. In most languages, probably in all cultivated languages, grammarians distinguish the following parts of speech: *Noun, pronoun, verb, participle, adverb, preposition, conjunction*. The *Latin* and *English* grammarians admit the *interjection* among the parts of speech, although it is confessedly not necessary to the construction of the sentence, being only thrown in to express the affection of the speaker: and in the *Greek* and *English* tongues there is the *article* prefixed to nouns, when they signify the common names of *things*, to point them out, and to show how far their signification extends. In the method of arrangement commonly followed in grammars, *adjectives* are classed with *substantives*, and both are denominated *nouns*; but it is certain that, when examined philosophically, an essential difference is discovered between the *substantive* and the *adjective*; and therefore some writers of eminence, when treating of this subject, have lately given the following classification of words which we shall adopt: **THE ARTICLE, NOUN, PRONOUN, VERB, PARTICIPLE, ADJECTIVE, ADVERB, PREPOSITION, CONJUNCTION, INTERJECTION**. All these words are to be found in the *English* language; and therefore we shall examine each

class, endeavour to ascertain its precise import, and show in what respects it differs from every other class. It is impossible to investigate the principles of grammar without confining the investigation in a great measure to some particular language from which the illustrations must be produced; and that we should prefer the *English* language for this purpose can excite no wonder, as it is a preference which to every tongue is due from those by whom it is spoken. We trust, however, that the principles which we shall establish will be found to apply *universally*; and that our inquiry, though *principally* illustrated from the *English* language, will be an inquiry into *philosophical* or *universal* grammar.

CHAP. I. Of the Noun or Substantive.

13. **NOUNS** are all those words by which objects or substances are denominated, and which distinguish them from one another, without marking either quantity, quality, action, or relation. The *substantive* or *noun* is the name of the thing spoken of, and in *Greek* and *Latin* is called *name*; for it is *onoma* in the one, and *nomen* in the other; and if in *English* we had called it the *name* rather than the *noun*, the appellation would perhaps have been more proper, as this last word, being used only in *grammar*, is more liable to be misunderstood than the other, which is in *constant* and *familiar* use. That *nouns* or the names of things must make a part of every language, and that they must have been the words first suggested to the human mind, will not be disputed. Men could not speak of themselves or of any thing else, without having names for themselves and the various objects with which they are surrounded. Now, as all the objects which exist must be either in the same state in which they were produced by *nature*, or changed from their original state by *art*, or *abstracted* from substances by the powers of imagination, and conceived by the mind as having at least the capacity of being characterized by qualities; this naturally suggests a division of nouns into **NATURAL**, as *man, vegetable, tree, &c.* **ARTIFICIAL**, as *house, ship, watch, &c.* and **ABSTRACT**, as *whiteness, motion, temperance, &c.*

14. But the diversity of objects is so great, that had each individual a distinct and proper name, it would be impossible for the most tenacious memory, during the course of the longest life, to retain even the *nouns* of the narrowest language. It has therefore been found expedient, when a number of things resemble each other in some important particulars, to arrange them all under one *species*; to which is given a name that belongs equally to the *whole species*, and to each *individual* comprehended under it. Thus the word *man* denotes a *species* of animals, and is equally applicable to every *human being*: The word *horse* denotes another species of animals, and is equally applicable to every individual of that species of *quadrupeds*; but it cannot be applied to the species of *men*, or to any *individual* comprehended under that species. We find, however, that there are some qualities in which several species resemble each other; and therefore we refer them to a *higher* order called a *genus*, to which we give a name that is equally applicable to every *species* and every *individual* comprehended under it. Thus, *men* and *horses* and all *living things* on earth resemble each other in this respect, that they have *life*. We refer them

10
The common division of the parts of speech the most proper.

Noun

11

The noun defined.

12

Different kinds of nouns.

13

Nouns general term

^{Noun.} them therefore to the *genus* called *animal*; and this word belongs to every *species* of animals, and to each *individual animal*. The same classification is made both of *artificial* and *abstract* substances; of each of which there are *genera*, *species*, and *individuals*. Thus in *natural* substances, *animal*, *vegetable*, and *fossil*, denote **GENERA**; *man*, *horse*, *tree*, *metal*, a **SPECIES**; and *Alexander*, *Bucephalus*, *oak*, *gold*, are **INDIVIDUALS**. In *artificial* substances, *edifice* is a **GENUS**; *house*, *church*, *tower*, are **SPECIES**; and the *Vatican*, *St Paul's*, and the *Tower of London*, are **INDIVIDUALS**. In *abstract* substances, *motion* and *virtue* are **GENERA**; *flight* and *temperance* are **SPECIES**; the *flight of Mahomet* and *temperance in wine* are **INDIVIDUALS**. By arranging substances in this manner, and giving a name to each *genus* and *species*, the *nouns* necessary to any language are comparatively few and easily acquired: and when we meet with an object unknown to us, we have only to examine it with attention; and comparing it with other objects, to refer it to the *genus* or *species* which it most nearly resembles. By this contrivance we supply the want of a proper name for the *individual*; and so far as the resemblance is complete between it and the *species* to which it is referred, and of which we have given it the name, we may converse and reason about it without danger of error: Whereas had each *individual* in nature a *distinct* and *proper* name, words would be innumerable and incomprehensible; and to employ our labours in language, would be as idle as that study of numberless written symbols which has been attributed to the *Chinese*.

¹⁴ The origin of the singular and plural numbers. 15. Although *nouns* are thus adapted to express not the *individuals* but the *genera* or *species* into which substances are classed; yet, in speaking of these substances, whether *natural*, *artificial*, or *abstract*, all men must have occasion to mention sometimes *one* of a kind, and sometimes *more* than one. In every language, therefore, nouns must admit of some variation in their form, to denote *unity* and *plurality*; and this variation is called *number*. Thus in the English language, when we speak of a single place of habitation, we call it a *house*; but if of more, we call them *houses*. In the first of these cases the noun is said to be in the *singular*, in the last case it is in the *plural*, number. Greek nouns have also a *dual* number to express *two* individuals, as have likewise some Hebrew nouns; but this variation is evidently not essential to language; and it is perhaps doubtful whether it ought to be considered as an elegance or a deformity.

16. But although number be a natural accident of nouns, it can only be considered as *essential* to those which denote *genera* or *species*. Thus we may have occasion to speak of *one animal* or of *many animals*, of *one man* or of *many men*; and therefore the nouns *animal* and *man* must be capable of expressing *plurality* as well as *unity*. But this is not the case with respect to the *proper* names of *individuals*: for we can only say *Xenophon*, *Aristotle*, *Plato*, &c. in the *singular*; as, were any one of these names to assume a *plural* form, it would cease to be the *proper* name of an *individual*, and become the *common* name of a *species*. Of this, indeed, we have some examples in every language. When a proper name is considered as a general appellation under which many others are arranged, it is then no longer the name of an *individual* but of a *species*, and

as *such* admits of a *plural*; as the *Cæsars*, the *Howards*, the *Pelhams*, the *Montagues*, &c.: but *Socrates* can never become *plural*; so long as we know of *no more* than *one* man of that name. The reason of all this will be obvious, if we consider that every *genus* may be found whole and entire in each of its *species*; for *man*, *horse*, and *dog*, are each of them an entire and complete *animal*: and every *species* may be found whole and entire in each of its *individuals*: for *Socrates*, *Plato*, and *Xenophon*, are each of them completely and entirely a *man*. Hence it is, that every *genus*, though **ONE**, is multiplied into **MANY**; and every *species*, though **ONE**, is also multiplied into **MANY**; by reference to those beings which are their *subordinates*: But as *no individual* has any *such subordinates*, it can never in strictness be considered as **MANY**; and so, as well in *nature* as in *name*, is truly an **INDIVIDUAL** which cannot admit of *number*.

¹⁵ Of gender. 17. Besides *number*, another characteristic, visible in substances, is that of **SEX**. Every substance is either *male* or *female*; or *both male and female*; or *neither one nor the other*. So that with respect to *sexes* and their *negation*, all substances conceivable are comprehended under this *fourfold* consideration, which language would be very imperfect if it could not express. Now the existence of *hermaphrodites* being rare, if not doubtful, and language being framed to answer the ordinary occasions of life, no provision is made, in any of the tongues with which we are acquainted, for expressing, otherwise than by a name made on purpose, or by a periphrasis, *duplicity* of *sex*. With regard to this great natural characteristic, grammarians have made only a threefold distinction of nouns: those which denote *males* are said to be of the *masculine gender*; those which denote *females*, of the *feminine*; and those which denote substances that admit not of *sex*, are said to be *neuter* or of *neither gender*. All animals have *sex*; and therefore the *names* of all animals should have *gender*. But the *sex* of all is not equally obvious, nor equally worthy of attention. In those species that are most common, or of which the *male* and the *female* are, by their *size*, *form*, *colour*, or other outward circumstances, *eminently distinguished*, the *male* is sometimes called by *one* name, which is *masculine*; and the *female* by a *different* name, which is *feminine*. Thus in English we say, *husband*, *wife*; *king*, *queen*; *father*, *mother*; *son*, *daughter*, &c. In others of similar distinction, the name of the *male* is applied to the *female* only by prefixing a syllable or by altering the termination; as *man*, *woman*; *lion*, *lioness*; *emperor*, *empress*, anciently *emperess*; *master*, *mistress*, anciently *masteress*, &c. When the *sex* of any animal is not obvious, or not material to be known, the same name, in some languages, is applied, without variation, to all the *species*, and that name is said to be of the *common gender*. Thus in Latin *bos albus* is a white ox, and *bos alba* a white cow. Diminutive insects, though they are doubtless male and female, seem to be considered in the English language as if they were really creeping things. No man, speaking of a *worm*, would say *he* creeps, but *it* creeps upon the ground. But although the origin of *genders* is thus clear and obvious; yet the English is the only language, with which we are acquainted, that deviates not, except in a very few instances, from the order of nature. Greek and Latin, and many of the modern tongues, have nouns,

Noun. some masculine, some feminine, which denote substances where sex never had existence. Nay, some languages are so particularly defective in this respect, as to class every object, inanimate as well as animate, under either the *masculine* or the *feminine gender*, as they have no *neuter gender* for those which are of neither sex. This is the case with the *Hebrew, French, Italian, and Spanish*. But the *English*, strictly following the order of nature, puts every noun which denotes a *male animal*, and no other, in the *masculine gender*; every name of a *female animal*, in the *feminine*; and every animal whose sex is not *obvious, or known*, as well as every *inanimate* object whatever, in the *neuter gender*. And this gives our language an advantage above most others in the poetical and rhetorical style: for when nouns naturally neuter are converted into masculine and feminine, the *personification* is more distinctly and more forcibly marked. (See PERSONIFICATION). Some very learned and ingenious men have endeavoured, by what they call a more subtle kind of reasoning, to discern even in things without sex a distant analogy to that NATURAL DISTINCTION, and to account for the names of inanimate substances being, in Greek and Latin, *masculine* and *feminine*. But such speculations are wholly fanciful; and the principles upon which they proceed are overturned by an appeal to facts. Many of the substances that, in one language, have *masculine names*, have in others names that are *feminine*; which could not be the case were this matter regulated by *reason or nature*. Indeed for this, as well as many other anomalies in language, no other reason can be assigned than that *custom*—

Quem penes arbitrium est, et jus, et norma, loquendi.

16
Origin of cases.

18. It has been already observed that most nouns are the names, not of *individuals*, but of whole classes of objects termed *genera* and *species* (B). In classing a number of *individuals* under *one species*, we contemplate only those qualities which appear to be important, and in which the several individuals are found to agree, abstracting the mind from the consideration of all those which appear to be less essential, and which in one individual may be such as have nothing exactly similar in any other individual upon earth. Thus, in classing the *individuals* which are comprehended under the *species* denominated *horse*, we pay no regard to their *colour* or the *size*; because experience teaches us, that no *particular* colour or size is essential to that individual living creature, and that there are not perhaps upon earth *two* horses whose colour and size are *exactly alike*. But the qualities which in this process we take into view, are the *general shape*, the *symmetry*, and *proportion* of the *parts*; and in short every thing which appears evidently *essential* to the *life* of the *individual* and the *propagation* of the *race*. All these qualities are strikingly similar in all the individuals which we call *horses*, and as strikingly dissimilar from the corresponding qualities of every *other* individual animal. The colour of a *horse* is of-

ten the same with that of an *ox*; but the shape of the one animal, the symmetry and proportion of his parts, are totally different from those of the other; nor could any man be led to class the *two individuals* under the *same species*. It is by a similar process that we ascend from one *species* to another, and through *all* the *species* to the highest *genus*. In each *species* or *genus* in the ascending series *fewer particular* qualities are attended to than were considered as *essential* to the *genus* or *species* immediately below it; and our *conceptions* become more and more *general* as the particular qualities, which are the objects of them, become *fewer in number*. The use of a *general term*, therefore, can recall to the mind only the *common* qualities of the *class*, the *genus* or *species* which it represents. But we have frequent occasion to speak of *individual* objects. In doing this, we annex to the *general term* certain words significant of *particular qualities*, which discriminate the object of which we speak, from every other individual of the class to which it belongs, and of which the *general term* is the *common name*. For instance, in advertising a *thief*, we are obliged to mention his *height, complexion, gait*, and whatever may serve to distinguish him from *all other men*.

The process of the mind in rendering her conceptions *particular*, is indeed exactly the reverse of that by which she *generalizes* them. For as in the process of *generalization*, she *abstracts* from her ideas of any number of *species* certain qualities in which they differ from each other, and of the *remaining* qualities in which they agree, constitutes the first *genus* in the ascending series; so when she wishes to make her conceptions more *particular*, she *annexes* to her idea of any *genus* those qualities or circumstances which were before abstracted from it; and the *genus*, with this *annexation*, constitutes the first *species* in the descending series. In like manner, when she wishes to descend from any *species* to an *individual*, she has only to *annex* to the idea of the *species* those *particular* qualities which discriminate the *individual intended* from the *other individuals* of the same kind.

This *particularizing* operation of the mind points out the manner of applying the *general terms* of language for the purpose of expressing *particular ideas*. For as the *mind*, to limit a *general idea*, connects that *idea* with the *idea* of some *particular circumstance*; so *language*, as we have already observed, in order to limit a *general term*, connects that *term* with the *word* denoting the particular circumstance. Thus, in order, to particularize the *idea* of horse, the *mind* connects that *general idea* with the *circumstance*, suppose, of *whiteness*; and in order to particularize the *word* horse, *language* connects that *word* with the *term* white: and so in other instances.—*Annexation*, therefore, or the connecting of general words or terms in language, fits it for expressing particular conceptions; and this must hold alike good in *all languages*. But the methods of *denoting* this *annexation* are various in various tongues. In *English* and most modern languages we commonly use for this purpose

(B It is almost needless to observe, that the words *genus* and *species*, and the phrases *higher genus* and *lower species*, are taken here in the *logical* sense; and not as the words *genus, species, order, class*, are often employed by naturalists. For a farther account of the mental process of generalization, see LOGIC and METAPHYSICS.

pose little words, which we have chosen to style *particles*; and in the *Greek* and *Latin* languages, the *cases of nouns* answer the same end.

19. *Cases*, therefore, though they are *accidents of nouns* not *absolutely necessary*, have been often considered as such; and they are certainly worthy of our examination, since there is perhaps no language in which *some cases* are not to be found, as indeed without *them* or their various *powers* no language could readily answer the purposes of life.

17 Cases, the marks of association. All the *oblique cases* of nouns (if we except the *vocative*) are merely marks of *annexation*; but as the *connections* or *relations* subsisting among *objects* are very various, *some cases* denote *one kind* of relation, and *some another*. We shall endeavour to investigate the connection which *each case* denotes, beginning with the *genitive*.—This is the *most general* of all the cases, and gives notice that *some connection* indeed subsists between *two objects*, but does not point out the *particular kind* of connection. That we must infer, not from our *nature* or termination of the *genitive itself*, but from our *precious knowledge* of the *objects connected*. That the *genitive* denotes merely *relation in general*, might be proved by adducing innumerable examples, in which the *relations* expressed by this case are *different*; but we shall content ourselves with one observation, from which the truth of our opinion will appear beyond dispute. If an expression be used in which are, connected by the *genitive case*, two words significant of objects between which a *twofold relation* may subsist, it will be found impossible, *from the expression*, to determine *which* of these two relations is the *true one*, which must be gathered wholly from the context. Thus, for example, from the phrase *injuria regis*, no man can know whether the *injury* mentioned be an *injury suffered* or an *injury inflicted* by the king; but if the *genitive case* notified any *particular relation*, no such ambiguity could exist. This case therefore gives notice, that two objects are, *somehow or other* (C), connected, but it marks not the *particular sort* of connection. Hence it may be translated by our particle *of*, which will be seen afterwards to be of a signification equally general.

18 The import of the genitive case.

19 Of the dative and accusative cases. The *dative* and *accusative cases* appear to have nearly the same meaning: each of them denoting *apposition*, or the junction of *one object with another*. Thus when any one says, *Comparo Virgilium Homero*, *Homer* and *Virgil* are conceived to be placed *beside one another*, in order to their being compared; and *this sort* of connection is denoted by the *dative case*. In like manner, when it is said *fatus humeros*, *breadth* is conceived as joined to or connected in *apposition with shoulders*; and the expression may be translated "broad at the shoulders."

This *apposition* of two objects may happen either *without previous motion*, or in *consequence of it*. In the foregoing instances *no motion* is *pre supposed*; but if one say, *Misit aliquos subsidio eorum*, the *apposition* is there in consequence of motion. In like manner, when

it is said, *Profectus est Romam*, his *apposition with Rome* is conceived as the *effect* of his *motion* thither.

Noun.

From this idea of the *accusative*, the reason is obvious why the object *after* the active verb is often put in that case; it is because the action is supposed to proceed *from the agent to the patient*. But the same thing happens with respect to the *dative case*, and for the *same reason*. Thus, *Antonius læsit Ciceronem*, and *Antonius nocuit Cicroni*, are expressions of the same import, and in each the action of *hurting* is conceived as proceeding *from Antony to Cicero*; which is finely illustrated by the passive form of such expressions, where the procedure above mentioned is expressly marked by the preposition *ab*: *Cicero nocetur*, *Cicero læditur ab Antonio*. It is therefore not true, that "the *accusative* is *that case*, at least the *only case*, which to an efficient nominative and a verb of action subjoins either the effect or the passive subject; nor is the *dative* the only case which is formed to express relations tending to itself." The only thing *essential* to these two cases is to denote the *apposition or junction of one object with another*; and this they do *nearly*, if not altogether, in the *same manner*, although from the *custom* of language they may not be indifferently subjoined to the same verb.

20 Of the ablative case. The Greek language has no *ablative case*: but in the Latin, where it is used, it denotes *concomitancy*, or that *one thing accompanies another*. From this *concomitancy* we sometimes draw an *inference*, and sometimes *not*. For example, when it is said, *Templum clamore petebant*, *clamour* is represented as *concomitant* with their going to the temple; and *here* no inference is drawn; but from the phrase *palleo metu*, although nothing more is expressed than that paleness is a *concomitant* of the fear, yet we instantly *infer* that it is also the *effect* of it. In most instances where the *ablative* is used, an *inference* is drawn, of which the foundation is some *natural connection* observed to subsist between the *objects* thus connected in *language*. When this inference is *not* meant to be drawn, the *preposition* is commonly added; as, *interfectus est cum gladio*, "he was slain with a sword about him;" *interfectus est gladio*, "he was slain with a sword as the *instrument* of his death."

21 Of the nominative and vocative cases. The remaining cases, which have not been noticed, are the *nominative* and the *vocative*. These are in most instances alike in termination, which makes it probable that they were originally *one and the same case*. The foundation of this conjecture will appear from considering the *use* to which each of these cases is applied. The *nominative* is employed to call up the idea of *any object* in the mind of the hearer. But when a man hears his *own name* mentioned, his attention is instantly roused, and he is naturally led to *listen to what is to be said*. Hence, when a man meant particularly to *solicit* one's attention, he would naturally pronounce that person's *name*; and thus the *nominative case* would pass into a *vocative*, of which the use is *always* to *solicit attention* (D).

20. The

(C) The Greek grammarians seem to have been aware of the nature of this case when they called it *σύνεσις*, *synesis*, or the *general case*: of which name the Latin grammarians evidently mistook the meaning when they translated it *casus genitivus*, or the *generative case*; a name totally foreign from its nature.

(D) The chief objection to this conjecture, that the *nominative* and *vocative* were originally the *same case*, is taken from the Latin tongue, in which the nouns of the second declension ending in *us* terminate their *vocative*

12
Noun.
Import of
the Greek
and Latin
cases.

20. The *Greek* and *Latin* among the *ancient*, and the *German* among the *modern* languages, express different connections or relations of one thing with another by *cases*. In *English* this is done for the most part by prepositions; but the *English*, being derived from the same origin as the *German*, that is, from the *Teutonic*, has at least *one* variation of the substantive to answer the same purpose. For instance, the relation of *possession*, or *belonging*, is often expressed by a different ending of the substantive, which may be well called a *case*. This case answers nearly to the *genitive case* in *Latin*; but as *that* is not a denomination significant of the *nature* of the case in any language, it may perhaps in *English* be more properly called the *possessive case*. Thus, *God's grace*, anciently *Godis grace*, is the *grace belonging to* or in the *possession of God*: and may be likewise expressed by means of the preposition; thus,—*the grace of God*.

13
One case
in English
to denote
possession.

Although the word *Godis* is as evidently an inflexion of the noun *God* as the word *Dei* is an inflexion of *Deus*, there are grammarians who have denied that in *English* there is *any* true inflexion of the original noun, and who have said that the noun with the addition of that syllable, which we consider as the *sign of a case*, *ceases* to be a *noun*, and becomes a *definitive*; a word which with them is devoid of signification. Thus, in the expression *Alexander's house*, the word *Alexander's* stands not as a *noun*, but as an *article* or *definitive*, serving to ascertain and point out the *individuality* of the house. But this is a palpable mistake: the word *Alexander's* serves *not* to point out the *individuality* of the house, but to show to whom the house *belongs*; and is therefore beyond dispute, not an *article*, but a *noun*, in the *possessive case*. Again, when we say *St Peter's* at Rome and *St Paul's* at London, the words *St Peter's* and *St Paul's* are neither *articles*, nor, as has been absurdly imagined, the proper names of edifices, like the *Rotundo* or the *Circus*; but they are in the *possessive case*, the names of the two apostles to whom the churches were *dedicated*, and to whom they are supposed to *belong*.

But that this, which we have called the *possessive case*, is really *not* so, must be evident, it is said, because there are certain circumstances in which it cannot be substituted for the noun with the preposition prefixed. Thus, though a man may say, I speak *of Alexander*, I write *of Cæsar*, I think *of Pompey*; he cannot say, I speak *Alexander's*, I write *Cæsar's*, or I think *Pompey's*. This is indeed true, but it is nothing to the purpose: for though I may say, *Loquor DE Alexandro*, *Scribo DE Cæsare*, *Cogito DE Pompeio*; I cannot say, *Loquor Alexandri*, *Scribo Cæsaris*, or *Cogito Pompeii*: and therefore all that can be inferred from this argument is, that as the *Latin genitive* is not always of the same import with the preposition *de*, so the *English possessive* is not always of the same import with the preposition *of*. Upon the whole, then, we may conclude, that *English nouns* admit of one inflexion; and

that though *cases* are not so essential to nouns as gender and number, no language can be wholly without them or their various powers.

Article.

CHAP. II. Of Articles or Definitives.

21. THE intention of language is to communicate thought, or to express those ideas which are suggested to us by our senses external and internal. The ideas first suggested to us are those of pain and pleasure, and of the objects with which we are surrounded; and therefore the words first learned must be *nouns*, or the names of objects natural, artificial, and abstract. Every object about which the human mind can be conversant is strictly and properly speaking *particular*; for all things in nature differ from one another in numberless respects, which, not to mention the idea of separate existence, so circumscribe and *individuate* them, that no one thing can be said to be another. Now the use of language being to express our ideas or conceptions of these objects, it might naturally be expected that every object should be distinguished by a *proper name*. This would indeed be agreeable to the truth of things, but we have already seen that it is altogether impracticable. Objects have therefore been classed into *genera* and *species*; and names given, *not* to each *individual*, but to each *genus* and *species*. By this contrivance of language, we are enabled to ascertain in some measure any *individual* that may occur, and of which we know not the proper name, only by referring it to the *genus* or *species* to which it belongs, and calling it by the *general* or *specific* name; but as there is frequent occasion to distinguish individuals of the same species from one another, it became necessary to fall upon some expedient to mark this distinction. In many languages *general* and *specific* terms are modified and restricted by three orders of words; the *ARTICLE*, the *ADJECTIVE*, and the *OBLIQUE CASES* of *NOUNS*. The *cases* of *nouns* we have already considered: the *adjective* will employ our attention afterwards: at present our observations are of the article confined to the *ARTICLE*; a word so very necessary, that without it or some equivalent invention men could not employ *nouns* to any of the purposes of life, or indeed communicate their thoughts at all. As the business of *articles* is to enable us, upon occasion, to employ *general terms* to denote *particular objects*, they must be considered in *combination* with the general terms, as merely *substitutes* for proper names. They have, however, been commonly called *definitives*; because they serve to *define* and *ascertain* any *particular object*, so as to *distinguish* it from the other objects of the general class to which it belongs, and, of course, to *denote* its *individuality*. Of words framed for this purpose, whether they have by grammarians been termed *articles* or not, we know of no language that is wholly destitute. The nature of them may be explained as follows.

24
The neces-
sity and u-
tility of the ar-
ticle.

22. An object occurs with which, as an *individual*, we are totally unacquainted; it has a head and limbs, and

tive in *e*. But this is easily accounted for. The *s* in such words was often dropt, as appears from the scanning of old Latin poetry; and when this was done, the *u* being short, would naturally in pronunciation pass into *e*, a like short vowel; and thus, in the *vocative case*, *e* would in time be written instead of *u*.

Article. and appears to possess the powers of self-motion and sensation: we therefore refer it to its proper *species*, and call it a *dog*, a *horse*, a *lion*, or the like. If it belongs to none of the species with which we are acquainted, it cannot be called by any of their names; we then refer it to the *genus*, and call it an *animal*.

²⁵
Two articles. But this is not enough. The object at which we are looking, and which we want to distinguish, is not a *species* or a *genus*, but an *individual*. Of what kind? *Known* or *unknown*? Seen now for the first time, or seen before and now remembered? This is one of the instances in which we shall discover the use of the two articles *A* and *THE*: for, in the case supposed, the article *A* respects our *primary* perception, and denotes an individual as *unknown*; whereas *THE* respects our *secondary* perception, and denotes individuals as *known*. To explain this by an example: I see an object pass by which I never saw till now. What do I say? *There goes a beggar with a long beard*. The man departs, and returns a week after: What do I then say? *There goes THE beggar with THE long beard*. Here the article only is changed, the rest remains unaltered. Yet mark the force of this apparently minute change. The individual *once vague* is now recognised as *something known*; and that merely by the efficacy of this latter article, which tacitly insinuates a kind of *previous* acquaintance, by referring a present perception to a like perception already past.

This is the explanation of the articles *A* and *THE* as given by the learned Mr Harris, and thus far what he says on the subject is certainly just; but it is not true that the article *THE* always insinuates a *previous* acquaintance, or refers a present perception to a like perception already past.—I am in a room crowded with company, of which the greater part is to me totally unknown. I feel it difficult to breathe from the grossness of the inclosed atmosphere; and looking towards the window, I see in it a person whom I never saw before. I instantly send my compliments to *THE gentleman in the window*, and request, that, if it be not inconvenient, he will have the goodness to let into the room a little fresh air. Of this gentleman I have no *previous acquaintance*; my present perception of him is my *primary* perception, and yet it would have been extremely improper to send my compliments, &c. to a *gentleman in the window*.—Again, there would be no impropriety in saying—“*A man* whom I saw yesterday exhibiting a show to the rabble, was this morning committed to jail charged with the crime of housebreaking.” Notwithstanding the authority, therefore, of Mr Harris and his master Apollonius, we may venture to affirm, that it is not *essential* to the article *A* to respect a *primary* perception, or to the article *THE* to indicate a *pre-established* acquaintance. Such may indeed be the manner in which these words are most frequently used; but we see that there are instances in which they may be used differently. What then, it may be asked, is the import of each article, and in what respects do they differ.

23. We answer, that the articles *A* and *THE* are both of them *definitives*, as by being prefixed to the names of *genera* and *species* they so circumscribe the latitude of those names as to make them for the most part denote *individuals*. A *noun* or *substantive*, without

any article to limit it, is taken in its widest sense. Thus the word *man* means all mankind;

Article.

“The proper study of mankind is man:”

where *mankind* and *man* may change places without making any alteration in the sense. But let either of the articles of which we are treating be prefixed to the word *man*, and that word is immediately reduced from the name of a *whole genus* to denote only a *single individual*; and instead of the noble truth which this line asserts, the poet will be made to say, that the proper study of mankind is not the common nature which is diffused through the whole human race, but the manners and caprices of *one individual*. Thus far therefore the two articles agree; but they differ in this, that though they *both* limit the specific name to *some individual*, the article *A* leaves the *individual itself unascertained*; whereas the article *THE* *ascertains the individual also*, and can be prefixed to the specific name only when an individual is intended, of which something may be predicated that distinguishes it from the other individuals of the species. Thus, if I say—*A man is fit for treasons*, my assertion may appear strange and vague; but the sentence is complete, and wants nothing to make it intelligible: but if I say—*THE man is fit for treasons*, I speak nonsense; for as the article *THE* shows that I mean *some particular* man, it will be impossible to discover my meaning till I complete the sentence, and predicate something of the individual intended to distinguish him from other individuals.

“THE man that hath not music in himself, &c.

“Is fit for treasons.”

A man, therefore, means some one or other of the human race *indefinitely*; *THE man* means, *definitely*, that particular man who is spoken of: the former is called the *indefinite*, the latter the *definite*, article.

The two articles differ likewise in this respect, that as the article *A* serves only to separate *one individual* object from the general class to which it belongs, it cannot be applied to *plurals*. It has indeed the same signification nearly with the numerical word *one*; and in French and Italian, the same word that denotes unity is also the article of which we now treat. But the essence of the article *THE* being to define objects, by pointing them out as those of which something is affirmed or denied which is not affirmed or denied of the other objects of the same class, it is equally applicable to *both* numbers: for things may be predicated of one *sex* of *men*, as well as of a *single man*, which cannot be predicated of *other men*. The use and import of each article will appear from the following example: “*Man* was made for Society, and ought to extend his good-will to *all men*; but *a man* will naturally entertain a more particular regard for *the men* with whom he has the most frequent intercourse, and enter into a still closer union with *the man* whose temper and disposition suit best with his own.”

We have said, that the article *A* cannot be applied to plurals, because it denotes unity: but to this rule there is apparently a remarkable exception in the use of the adjectives *few* and *many* (the latter chiefly with the word *great* before it), which, though joined with *plural substantives*, yet admit of the *singular article A*:

as,

Article. as, *a few men, a great many men.* The reason of this is manifest from the effect which the article has in these phrases: it means a small or a great number *collectively* taken, to which it gives the idea of a *whole*, that is, of *unity*. Thus likewise *a hundred, a thousand, is one whole number*, an aggregate of many collectively taken, and therefore still retains the article *A* though joined as an adjective to a plural substantive; as, *a hundred years.* The exception therefore is only apparent; and we may affirm, that the article *A* *universally* denotes *unity*.

24. The indefinite article is much less useful than the other; and therefore the Greek and Hebrew languages have it not, though they both have a definite article. In languages of which the *nouns, adjectives, and verbs*, have inflexion, no mistake can arise from the want of the *indefinite* article; because it can always be known by the *terminations* of the *noun* and the *verb*, and by the circumstances predicated of the noun, whether a *whole species* or *one individual* be intended. But this is not the case in English. In that language, the adjectives having no variation with respect to gender or number, and the tenses of the verbs being for the most part the same in both numbers, it might be often doubtful, had we not the indefinite article, whether the *specific name* was intended to express the *whole species* or only *one individual*. Thus, if we say in English, "*Man was born sent from God.*" we must be understood to mean that the birth of *every man* is from God, because to the specific term the indefinite article is not prefixed. Yet the words *ἕνασθε ἀνθρώπους ἀπεσταλμένους παρὰ Θεοῦ* convey no such meaning to any person acquainted with the Greek language; as the word *ἀνθρώπους*, without any article, is restricted to an individual by its concord with the verb and the participle; and the sense of the passage is, *A man was born (or existed) sent from God.* But though the *Greeks* have no article correspondent to the article *A*, yet nothing can be more nearly related than their *ὁ* to our *THE*, *ὁ βασιλεὺς*—*THE king*; *τὸ δῶρον*—*THE gift*. In one respect, indeed, the Greek and English articles differ. The former is varied according to the gender and number of the noun with which it is associated, being *ὁ*—*masculine*, *ἡ*—*feminine*, *το*—*neuter*; and *οἱ, αἱ, τα*, in the *plural number*: whereas the English article suffers no change, being invariably *THE* before nouns of every gender and in both numbers. There are, however, some modern languages which, in imitation of the Greek, admit of a variation of their article which relates to gender; but this cannot be considered as *essential* to this species of words, and it may be questioned whether it be an improvement to the language. In tongues of which the nouns have no inflexion, it can only serve to perplex and confuse, as it always presents a particular idea of *sex* where in many cases it is not necessary.

27
A greater number of articles in the English language than is commonly supposed.

25. The articles already mentioned are allowed to be strictly and properly such by every grammarian; but there are some words, such as *this, that, any, some, all, other, &c.* which are generally said to be sometimes *articles* and sometimes *pronouns*, according to the different modes of using them. That words should change their *nature* in this manner, so as to belong sometimes to *one part* of speech, and sometimes to *another*, must to every unprejudiced person appear very extraordinary; and if it were a fact, language would

be a thing so equivocal, that all inquiries into its nature upon principles of science and reason would be vain. But we cannot perceive any such fluctuation in any word whatever; though we know it to be a general charge brought against words of almost every denomination, of which we have already seen *one* instance in the *possessive case of nouns*, and shall now see *another* in those words which are commonly called *pronominal articles*.

If it be true, as we acknowledge it to be, that the genuine PRONOUN *always stands by itself*, assuming the power of a *noun*, and supplying its place, then is it certain that the words *this, that, any, some, &c.* can never be PRONOUNS. We are indeed told, that when we say *THIS is virtue, give me THAT, the words this and that are pronouns*; but that when we say, *THIS HABIT is virtue, THAT MAN defrauded me*, then are they *articles or definitives*. This, however, is evidently a mistake occasioned by overlooking those abbreviations in construction which are frequent in every language, and which, on account of that very frequency, have perhaps escaped the attention of grammarians whose sagacity has been successfully employed on matters less obvious.—When we say *THIS is virtue*, it is evident that we communicate no intelligence till we add *a substantive* to the word *this*, and declare *what* is virtue. The word *this* can therefore in no instance assume the power of a noun, since the noun to which it relates, though for the sake of dispatch it may be omitted in writing or conversation, must always be supplied by the mind of the reader or hearer, to make the sentence intelligible, or *this* itself of any importance.—“When we have viewed speech analysed, we may then consider it as compounded. And here, in the first place, we may contemplate that *synthesis*, which by combining simple terms produces a truth; then by combining two truths produce a third; and thus others and others in continued demonstration, till we are led, as by a road, to the regions of science. Now *THIS* is that superior and most excellent synthesis which alone applies itself to our intellect or reason, and which to conduct according to rule constitutes the *art of logic*. After *THIS* we may turn to those inferior compositions which are productive of the pathetic,” &c.—Here, if any where, the word *THIS* may be thought to *stand by itself*, and to assume the power of a noun; but let any man complete the construction of each sentence, and he will perceive that *THIS* is no more than a *definite article*. Thus,—“we may contemplate that *synthesis* which by combining simple terms produces a truth; then by combining two truths produces a third truth; and thus other truths and other truths in continued demonstration, till we are led, as by a road, into the regions of science. Now *THIS combination of truths* is that superior and most excellent synthesis which alone applies itself to our intellect or reason, and which to conduct according to rule constitutes the *art of logic*. After we have contemplated *THIS art*, we may turn,” &c.

The word *THAT* is generally considered as still more equivocal than *this*; for it is said to be sometimes an *article*, sometimes a *pronoun*, and sometimes a *conjunction*. In the following extract it appears in all these capacities; and yet, upon resolving the passage into parts and completing the construction, it will be found to be invariably a *definite article*.—“It is necessary to that per-

Articles

Articles

fection, of which our present state is capable, *that* the mind and body should both be kept in action; *that* neither the faculties of the one nor of the other be suffered to grow lax or torpid for want of use: but neither should health be purchased by voluntary submission to ignorance, nor should knowledge be cultivated at the expence of health; for *that* must enable it either to give pleasure to its possessor, or assistance to others." If this long sentence be resolved into its constituent parts, and the words be supplied which complete the construction, we shall see the import of the word **THAT** to be precisely the same in each clause. "The mind and body should both be kept in action; **THAT** action is necessary to **THAT** perfection of which our present state is capable: neither the faculties of the one nor of the other should be suffered to grow lax or torpid for want of use; *the degree of action proper to prevent THAT lazness is necessary*: but neither should health be purchased by voluntary submission to ignorance, nor should knowledge be cultivated at the expence of health; for **THAT health** must enable it either to give pleasure to its possessor, or assistance to others." Again:

"He **that's** unskilful will not toss a ball:"

"A man unskilful (he is *that*) will not toss a ball." Here the word **THAT**, though substituted for what is called the *relative pronoun* (**E**), still preserves unchanged its definitive import; and in every instance, except where it may be used very improperly, it will be found to be neither more nor less than a *definite article*.

26. It appears then, that if the *essence of an article be to define and ascertain*, the words *this* and *that*, as well as *any, some, all, &c.* which are commonly called *pronominal articles*, are much more properly *articles* than any thing else, and as such should be considered in universal grammar. Thus, when we say, *THIS picture I approve*, but *THAT I dislike*; what do we perform by the help of the words **THIS** and **THAT**, but bring down the common appellative to denote two individuals; the one as *the more near*, the other as *the more distant*? So when we say, *SOME men are virtuous, but ALL men are mortal*; what is the natural effect of this **ALL** and **SOME**, but to define that *universality* and *particularity* which would remain indefinite were we to take them away? The same is evident in such sentences as, *SOME substances have sensation, OTHERS want it; Choose ANY way of acting, and SOME men will find fault, &c.*: for here **SOME**, **OTHER**, and **ANY**, serve all of them to *define* different parts of a given whole; **SOME**, to denote any *indeterminate part*; **ANY**, to denote an *indefinite mode of action, no matter what*; and **OTHER**, to denote the *remaining part*, when a part has been assumed already.

27. We have said that the *article* is a part of speech so very necessary, that without it, or some equivalent invention (**F**), mankind could not communicate their thoughts; and that of words falling under this description, we know of no language which is wholly destitute. We are aware that these positions may be controverted; and that the *Latin* may be instanced as a language

which, without *articles*, is not only capable of communicating the ordinary thoughts of the speaker to the mind of the hearer, but which, in the hands of *Cicero, Virgil, and Lucretius*, was made to serve all the purposes of the most profound philosopher, the most impassioned orator, and the sublimest poet. That the *Latin* has been made to serve all these purposes cannot be denied, although *Lucretius* and *Cicero* both complain, that on the subject of *philosophy*, where the use of articles is most conspicuous, it is a deficient language. But should we grant what cannot be demanded, that those two great men were unacquainted with the powers of their native tongue, our positions would still remain unshaken; for we deny that the *Latin* is wholly without articles. It has indeed no word of precisely the same import with our **THE** or the *Greek* δ ; but the place of the indefinite article **A** might be always supplied, if necessary, with the numerical word *unus*. It may be so even in English; for we believe there is not a single instance where the words *one man, one horse, one virtue*, might not be substituted for the words *a man, a horse, a virtue, &c.* without in the slightest degree altering the sense of the passage where such words occur. This substitution, however, can be but very seldom if ever necessary in the *Latin* tongue, of which the precision is much greater than that of the *English* would be without articles; because the oblique cases of the *Latin* nouns, and the inflexion of its verbs, will almost always enable the reader to determine whether an appellative represents a whole species or a single individual.—The want of the definite article **THE** seems to be a greater defect; yet there are few instances in which its place might not be supplied by **THIS** or by **THAT** without obscuring the sense; and the *Latin* tongue is by no means deficient of articles corresponding to these two. Let us substitute the words **ONE** and **THAT** for **A** and **THE** in some of the foregoing examples, and we shall find, though the sound may be uncouth, the sense will remain. Thus,

"**THAT** man who hath not music in himself, &c.

"Is fit for treasons,"

conveys to the mind of the reader the very same sentiment which the poet expresses by the words "**THE** man that hath not music," &c. Again, "*Man* was made for society, and ought to extend his good-will to *all men*; but *one* man will naturally entertain a more particular regard for *those men* with whom he has the most frequent intercourse, and enter into a still closer union with *that man* whose temper and disposition suit best with his own." Now the words **HIC** and **ILLE** being exactly of the same import with the words **THIS** and **THAT**; it follows, that wherever the place of the article **THE** may in *English* be supplied by **THIS** or by **THAT**, it may in *Latin* be supplied by **HIC** or by **ILLE**. This is the case with respect to **NATHAN'S** reproof of **DAVID**, where the definite article is indeed most emphatical. The original words might have been translated into English, "thou art *that* man," as well as "thou art

(E) See more of this afterwards.

(F) As in the Persian and other eastern languages, in which the place of our indefinite article is supplied by a termination to those nouns which are meant to be particularized.

Articles in the Latin language.

Articles. art the man;” and in *Latin* they may with the utmost propriety be rendered, “Tu es ille homo.” Indeed the words HIC and ILLE, and we might instance many more, though they are commonly called *pronouns*, are in truth nothing but *definite articles*: HIC is evidently *his*; and ILLE is most probably derived from the Hebrew word *ah*, in the plural *ale*; which may be translated indifferently, either THE or THAT. But what proves beyond dispute that these two words are not *pronouns* but *articles*, is, that in no single instance will they be found to stand by themselves and assume the power of *nouns*. For the sake of dispatch, or to avoid disagreeable repetitions, the *noun* may indeed be often omitted; but it is *always supplied* by the reader or hearer, when HIC and ILLE appear in their proper place, and are seen to be invariably *definite articles*. We shall give an example of the use of each word, and dismiss the subject.

28
Hic and
Ille arti-
cles.

In the first oration against Catiline, Cicero begins with addressing himself in a very impassioned style to the traitor, who was present in the senate-house. He then exclaims pathetically against the manners of the age, and proceeds in these words: *Senatus hæc intelligit, consul videt: HIC tamen vivit. Vivit? immo verociam in senatum venit: fit publici consilii particeps.* In this passage HIC cannot be a pronoun; for from the beginning of the oration there occurs not a single *noun* of which it can possibly supply the place. When the orator uttered it, he was probably *pointing with his finger* at Catiline, and every one of his audience would supply the *noun* in his own mind, as we do when we translate it, “Yet *this* traitor lives.” When Virgil says,

ILLE ego, qui quondam gracili modulatus avena
Curmen,

it is obvious that he means, *I am THAT MAN*, or THAT POET, *who sung*, &c.; and though we may translate the words “I am *he* who tuned his song,” &c. yet when we construe the passage, we are under the necessity of supplying either *vates* or *vir*, which shows that ILLE is nothing more than a definite article signifying THAT or THE. It appears then, that the *Latin* tongue is not wholly destitute of articles, as few cases can occur where the Greek; and our THE may not be supplied by the words HIC and ILLE; which have in our opinion been very improperly termed *pronouns*. If there be any such cases, we can only confess that the *Latin* language is defective; whereas, had it *no* articles, it is not easy to conceive, how it could answer, to a cultivated people, the ordinary purposes of speech.

28. The articles THIS and THAT, unlike A and THE, are varied according as the noun, with which they are associated, is in the singular or in the plural number. Thus we say—*this* and *that man* in the singular, and *these* and *those men* in the plural. The *Latin* articles *hic* and *ille*, for such we will call them, are varied like the Greek δ , not only with the number, but also with the gender of their nouns. In languages, where the structure of a sentence may be so changed from the order of nature, as it commonly is in Greek and Latin, and where the reader is guided, not by the *position* but by the *terminations* of the words, to those which are in concord and those which are not, these variations of the articles have their use; but in English they are of no

importance.—Were it not that the custom of the language—the *forma loquendi*, as Horace calls it—has determined otherwise, there would be no more impropriety in saying *this*, or *that men*, than in saying *some men*, or *the men*.

29. As articles are by their nature definitives, it follows of course, that they cannot be united with such words as are in their own nature *as definite as they may be*; nor with such words as, *being undefinable, cannot properly be made otherwise*; but only with those words *which, though indefinite, are yet capable through the article of becoming definite*. Hence the reason why it is absurd to say, THE I, or THE THOU; because nothing, as will be seen afterwards, can make these pronouns more *definite* than they are of themselves; and the same may be said of proper names. Neither can we say, THE BOTH, because the word BOTH is *in its own nature* perfectly defined. Thus if it be said—“I have read both poets,”—this plainly indicates a *definite pair*, of whom some mention has been made already. On the contrary, if it be said, “I have read two poets,” this may mean *any pair* out of all that ever existed. And hence this numeral being in this sense indefinite (as indeed are all others as well as itself), is forced to assume the article whenever it would become *definite*. Hence also it is, that as TWO, when taken alone, has reference to some *primary* and *indefinite* perception, while the article THE has reference to some perception *secondary* and *definite*, it is bad language to say, TWO THE MEN, as this would be *blending of incompatibles*, that is, it would be representing two men as *defined* and *undefined* at the same time. On the contrary, to say BOTH THE MEN, is good language; because the substantive cannot possibly be less apt, by being defined, to coalesce with a numeral adjective which is defined as well as itself. So likewise it is correct to say, THE TWO MEN, THESE TWO MEN, or THOSE TWO MEN; because here the article, being placed at the beginning, *extends its power*, as well through the numeral adjective as the substantive, and tends equally to *define* them both.

30. As some of the above words admit of no article, because they are by nature *as definite as may be*; so there are others which admit it not, because they are not to be *defined at all*. Of this sort are all INTERROGATIVES. If we question about *substances*, we cannot say, THE WHO IS THIS, but WHO IS THIS? And the same as to *qualities* and both *quantities*: for we say, without an article, WHAT SORT OF, HOW MANY, HOW GREAT? The reason is, the article THE respects beings of which we can *predicate something*: but interrogatives respect beings about which we are *ignorant*, and of which we can therefore *predicate nothing*; for as to what we know, interrogation is superfluous. In a word, the *natural as-*

30
sociators with articles are ALL THOSE COMMON APPELLATIVES WHICH DENOTE THE SEVERAL GENERA AND SPECIES OF BEINGS: and it may be questioned whether, in strictness of speech, they are ever associated with any other words.

31. We have said that proper names admit not of the article, being, in their *own nature*, definite. This is true, whilst each name is confined to *one individual*; but as different persons often go by the same name, it is necessary to distinguish these from one another, to prevent the ambiguity which this identity of name would otherwise occasion. For this purpose we are obliged

Articles.
With what
words arti-
cles can-
not be uni-
ted.

With what
words they
naturally
associate.

Articles. obliged to have recourse to *adjectives* or *epithets*. For example, there were two *Grecian chiefs* who bore the name of *Ajax*; and it was not without reason that *Mnestheus* used *epithets* when his intention was to distinguish the one from the other: "If both *Ajaxes* cannot be spared (said he), at least let mighty *Telamonian Ajax* come." But as epithets are diffused through various subjects, in as much as the same adjective may be referred to many substantives, it has been said to be necessary, in order to render both parts of speech equally definite, that the adjective itself assume an article before it, which may indicate a reference to some single person only. It is thus we say—*Trypho THE Grammarian*; *Apollodorus THE Cyrenian*, &c. This is the doctrine of *Mr Harris*; from which, though we have the highest respect for the learning of the author, we feel ourselves obliged to dissent. In the examples given, the article *THE* is certainly not associated with the words *Grammarian* and *Cyrenian*, in the same manner in which it is associated with the word *man* in the sentence—"The man that hath not music in himself," &c. When we say *Apollodorus the Cyrenian*, we may, without fully or impertinence, be asked—the *Cyrenian* **WHAT** (C)? And the moment this question is answered, it will be seen that the article defines, not an adjective, but a substantive. If the answer be, the *Cyrenian philosopher*, the article *THE* is associated with the word *philosopher*, and the phrase *Apollodorus THE Cyrenian*, is an abbreviation of *Apollodorus THE philosopher of Cyrene*. In like manner, *Trypho THE grammarian*, is *Trypho THE grammarian writer*, or *Trypho THE writer of grammar*. Such abbreviations are very common. We familiarly say *THE SPEAKER*, and are understood to mean a high officer in the British parliament; yet, as *speaker* is a name common to many men, we may, without impropriety, be asked, *what speaker* we mean? and if so, we must reply, *the speaker of the house of commons*. But that which is eminent is supposed to be generally known; and therefore, in common language, *THE SPEAKER* is deemed a sufficient designation of him who presides over the lower house of parliament. Hence, by an easy transition, the definite article, from denoting *reference*, comes to denote *eminence* also: that is to say, from implying an ordinary pre-acquaintance, to presume a kind of general and universal notoriety. Thus *A KING* is any king; but *THE KING* is that person whom we acknowledge for our sovereign, the *king of Great Britain*. In Greek too, as in English, the article is often a mark of eminence; for the *POET* meant *Homer*, and *THE STACYRITE* meant *Aristotle*; not but that there were many poets besides *Homer*, and many *Stagyrites* besides *Aristotle*, but none equally illustrious.

³¹
The great utility of this species of words.

32. Before we dismiss the *ARTICLE*, we shall produce one example to show the utility of this species of words; which, although they may seem to be of small importance, yet, when properly applied, serve to make a few general terms sufficient for expressing, with accuracy, all the various objects about which mankind can have occasion to converse. Let *MAN* be the general term, which I have occasion to employ for the purpose of denoting some particular. Let it be required to

express this particular as *unknown*; I say *A MAN*:—**Pronouns.** *Known*; I say *THE man*:—*Definite*; *A CERTAIN man*:—*Indefinite*; *ANY man*:—*Present, and near*; *THIS man*:—*Present, and at some distance*; *THAT man*:—*Like to some other*; *SUCH a man*:—*Different from some other*; *ANOTHER man*:—*An indefinite multitude*; *MANY men*:—*A definite multitude*; *A THOUSAND men*:—*The ones of a multitude, taken throughout*; *EVERY man*:—*The same ones taken with distinction*; *EACH man*:—*Taken in order*; *FIRST man, SECOND man, &c.*:—*The whole multitude of particulars taken collectively*; *ALL men*:—*The negation of that multitude*; *NO man*:—*A number of particulars present and near*; *THESE men*:—*At some distance, or opposed to others*; *THOSE men*:—*A number of individuals separated from another number*; *OTHER men*:—*A small indefinite number*; *FEW men*:—*A proportionally greater number*; *MORE men*:—*A smaller number*; *FEWER men*:—And so on we might go almost to infinitude. But not to dwell longer upon this subject, we shall only remark, "that minute changes in *PRINCIPLES* lead to mighty changes in effects; so that *PRINCIPLES* are well entitled to regard, however trivial they may appear."

CHAP. III. Of Pronouns, or Substantives of the second order.

33. To men who are neither intoxicated with their own abilities, nor ambitious of the honour of building new systems, little pleasure can accrue from differing upon points of science from writers of great and deserved reputation. In such circumstances a man of modesty, although he will not upon the authority of a celebrated name adopt an opinion of which he perceives not the truth, must always advance his own notions with some degree of diffidence, as being conscious that the truth which he cannot perceive, may be visible to a keener and more perspicacious eye. In these circumstances we feel ourselves with regard to some of the most celebrated writers on grammar, from whom, concerning one or two points, comparatively indeed of but little importance, we have already been compelled reluctantly to differ. In treating of pronouns we are likely to deviate still farther from the beaten track; but that we may not be accused of acting the part of dogmatists in literature, and of claiming from others that implicit confidence which we refuse to give, we shall state with fairness the commonly received opinions, point out in what respects we think them erroneous, assign our reasons for calling them in question, and leave our readers to judge for themselves. The most celebrated writer in English who has treated of pronouns, and whom, since the publication of his *Hermes*, most other writers have implicitly followed, is *Mr HARRIS*, who, after a short introduction, proceeds thus:

34. "All conversation passes between *individuals* ³² The commonly supposed imp-
who will often happen to be till that instant *unacquainted* ^{posed imp-}
with each other. What then is to be done? How shall ^{personal}
the speaker address the other, when he knows not his ^{pronouns.}
name? or how explain himself by his own name, of
which the other is wholly ignorant? Nouns, as they
have

C 2

(C) Man or child, philosopher, orator, poet, or soldier, &c.?

Pronouns. have been described, cannot answer this purpose. The first expedient upon this occasion seems to have been pointing, or indicating by the finger or hand; some traces of which are still to be observed, as a part of that action which naturally attends our speaking. But the authors of language were not content with this: they invented a race of words to supply this pointing; which words, as they always stood for substantives or nouns, were characterised by the name of PRONOUNS. These also they distinguished into three several sorts, calling them pronouns of the first, the second, and the third person, with a view to certain distinctions, which may be explained as follows.

“Suppose the parties conversing to be wholly unacquainted, neither name nor countenance on either side known, and the subject of the conversation to be the speaker himself. Here to supply the place of pointing, by a word of equal power, the inventors of language furnished the speaker with the pronoun I; I write, I say, I desire, &c.: and as the speaker is always principal with respect to his own discourse, this they called, for that reason, the pronoun of the first person.

“Again, suppose the subject of the conversation to be the party addressed. Here, for similar reasons, they invented the pronoun THOU; THOU writest, THOU walkest, &c.: and as the party addressed is next in dignity to the speaker, or at least comes next with reference to the discourse, this pronoun they therefore called the pronoun of the second person.

“Lastly, suppose the subject of conversation neither the speaker nor the party addressed, but some third object different from both. Here they provided another pronoun, HE, SHE, or IT; which, in distinction to the two former, was called the pronoun of the third person: And thus it was that pronouns came to be distinguished by their respective PERSONS.”

36. The description of the different PERSONS here given is taken, we are told, from PRISCIAN, who took it from APOLLONIUS. But whatever be the deference due to these ancient masters, their learned pupil, though guided by them, seems not to have hit upon the true and distinguishing characteristic of the personal pronouns. He supposes, that when the names of two persons conversing together are known to each other, they may, by the use of these names, express all that the personal pronouns express: but this is certainly not true. To us, at least, there appears to be a very material difference between saying, “George did this,” and “I did this;” nor do we think that the power of the pronoun would be completely supplied by the name, even with the additional aid of indication by the hand. So when one man says to another, with whom he is conversing, “James did so and so;” it is surely not equivalent to his saying, “you did so and so.” If such were the case, one might pertinently ask, when both persons are known to each other, Why do they use the personal pronouns? Mr Harris tells us, that “when the subject of conversation is the speaker himself, he uses I; and when it is the party addressed, he uses THOU.” But in fact the nature of the personal pronouns has no sort of connection with the subject of conversation, whether that conversation relate to the speaker, the party addressed, or a Greek book. In this sentence, “I say that the three angles of every triangle are equal to two right angles,” the speaker is surely not the sub-

ject of the discourse; nor is the party addressed, but the truth of his assertion, the subject of discourse in the following sentence;—“You say, that Horne Tooke’s Divisions of Purley is the most masterly treatise on grammar, so far as it goes, that you have ever seen.” Mr Harris uses the phrase, becoming the subject of conversation, in no other sense than that when the speaker has occasion to mention HIMSELF, he uses I; when the party addressed, THOU; and when some other person or thing, HE, SHE, or IT: but we know that we may use other words, by no means equivalent to the two first of these pronouns, which will sufficiently mark himself, and the party addressed; and that he may use indifferently, and without the smallest injury to the sense, either the third pronoun, or the word for which it is merely a substitute. A man who bears various characters, may design HIMSELF by any one of them. Thus Mr PITT may speak of himself as first lord of the treasury, chancellor of the exchequer, or member for the university of Cambridge; and in each case he would be what Mr Harris calls the subject of conversation: yet every one feels that none of these designations is equivalent to I. What then is the force of the personal pronouns?

37. It appears to be simply this: The first denotes the speaker, as CHARACTERISED BY THE PRESENT ACT OF SPEAKING in contradistinction to every other character which he may bear. The second denotes the party addressed, as CHARACTERISED BY THE PRESENT CIRCUMSTANCE OF BEING ADDRESSED, in contradistinction to every other character, &c.: And what is called the pronoun of the third person is merely a NEGATION OF THE OTHER TWO, as the neuter gender is a negation of the masculine and feminine. If this account of the personal pronouns be true, and we flatter ourselves that its truth will be obvious to every body, there is but one way of expressing by other words the force of the pronouns of the first and second person. Thus, “The person who now speaks to you did so and so,” is equivalent to “I did so and so;” and “The person to whom I now address myself did so and so,” is equivalent to “You did so and so.”

Hence we see why it is improper to say the I or the THOU; for each of these pronouns has of itself the force of a noun with the definite article prefixed, and denotes a person of whom something is predicted, which distinguishes him from all other persons. I is the person who now speaks, THOU is the person who is now addressed by the speaker. Hence too we see the reason why the pronoun I is said to be of the first, and the pronoun THOU of the second person. These pronouns can have place only in conversation, or when a man, in the character of a public speaker, addresses himself to an audience; but it is obvious, that there must be a speaker before there can be a hearer; and therefore, that the pronouns may follow the order of nature, I, which denotes the person of the speaker, must take place of THOU, which denotes the person of the hearer. Now the speaker and the hearer being the only persons engaged in conversation or declamation, I is with great propriety called the pronoun of the first, and THOU the pronoun of the second person. We have said, that, with respect to pronouns, the third person, as it is called, is merely a negative of the other two. This is evident from the slightest attention to the import of those words which are called pronouns of the third person. HE, SHE, or IT, denotes not the person either of the speaker or of the hearer;

Pronoun. end, as we have just observed, no other person can have a share in conversation or declamation. An absent person or an absent thing may be the *subject* of conversation, but cannot be the *speaker* or the *person addressed*. HE, SHE, and IT, however, as they *stand by themselves*, and assume the *power of nouns*, are very properly denominated *pronouns*; but they are not *personal* pronouns in any other sense than as the *negation of sex* is the *neuter gender*.

all other properties and attributes whatever, except **Pronoun.** those mentioned above as *descriptive* of the *nature* of these pronouns, are foreign from the intention of the speaker, who, when he uses the pronoun *I*, means THE PERSON WHO NOW SPEAKS—no matter whether man or woman: and when the pronoun THOU—THE PERSON—no matter whether man or woman—TO WHOM HE NOW ADDRESSES HIMSELF—and nothing more.

38. We have already seen that nouns admit of number; *pronouns*, which are their substitutes, likewise admit of number. There may be MANY speakers at once of the *same* sentiment, as well as *one*, who, including himself, speaks the sentiment of MANY; speech may likewise be addressed to MANY at a time, as well as to ONE; and the subject of the discourse may likewise be MANY. The pronoun, therefore, of every one of the *persons* must admit of number to express this *singularity* or *plurality*. Hence the pronoun of the first person *I*, has the plural WE; that of the second person THOU, has the plural *YE* or *YOU*; and that of the third person HE, SHE, or IT, has the plural THEY, which is equally applied to all the three genders.

But the pronoun of the third person denoting neither the *speaker* nor the *hearer*, but the *subject* of the discourse, and being merely the substitute of a *noun* which may be either *masculine*, *feminine*, or *neuter*, must of necessity agree with the noun which it represents, and admit of a triple distinction significant of gender. In the English, which allows its adjectives no genders, this pronoun is HE in the *masculine*, SHE in the *feminine*, and IT in the *neuter*; the utility of which distinction may be better found in supposing it away. Suppose for example, that we should in history read these words: *He caused him to destroy him*—and were informed that the pronoun, which is here thrice repeated, stood each time for something different; that is to say, for a man, for a woman, and for a city, whose names were *Alexander*, *Thais*, and *Persepolis*. Taking the pronoun in this manner—divested of its gender—how would it appear which was destroyed, which the destroyer, and which the cause that moved to the destruction? But there is no ambiguity when we hear the genders distinguished: when we are told with the proper distinctions, that SHE caused HIM to destroy IT, we know with certainty, that the *prompter* was the *woman*; that her *instrument* was the *hero*; and that the *subject* of their cruelty was the *unfortunate city*.—From this example we would be surprised how the *Italians*, *French*, and *Spaniards*, could express themselves with precision or elegance with no more than two variations of this pronoun.

34 The second personal pronoun used in the plural number when only one person is addressed. Although in this case we apply YOU to a *single* person, yet the *verb* must agree with it in the *plural number*; it must necessarily be, *you have*, not *you hast*. YOU WAS—the *second person plural* of the *pronoun* placed in agreement with the *first* or *third person singular* of the *verb*, is an enormous, though common, solecism, which ought to be carefully avoided. In very solemn style, as when we address the Supreme Being, we use THOU—perhaps to indicate that *he is God alone*, and that *there is none like unto him*; and we sometimes use the same form of the pronoun in contemptuous or very familiar language, to intimate that the person to whom we speak is the *meanest* of human beings, or the *dearest* and *most familiar* of our friends. A king, exerting his authority on a solemn occasion, adopts the *plural* of the first person, “WE strictly command and charge;” meaning, that he acts by the advice of counsellors, or rather as the representative of a whole people. But in all cases in which the *use of the pronoun* deviates from the *nature of things*, the *verb in concord* deviates with it; for, as will be seen afterwards, these two words universally agree in number and person.

37 The cases of pronoun. 40. Although in every language with which we are acquainted, there is but one pronoun for each of the first and second persons; and although it is obvious from the nature and import of those words, that no more can be necessary; yet the mere *English* reader may perhaps be puzzled with finding three distinct words applied to each; I, MINE, and ME, for the *first* person; THOU, THINE, and THEE, for the *second*. The learned reader will see at once that the words MINE and ME, THINE and THEE, are equivalent to the *genitive* and *accusative cases* of the Latin pronouns of the first and second persons. That MINE is a pronoun in the possessive case is obvious; for if I were asked “whose book is that before me?” I should reply—“It is MINE (I);” meaning that it belongs to me. That

35 The pronouns of the first and second person have no variations to denote sex, and why. 39. But though all these pronouns have *number*, neither in *Greek*, *Latin*, or any modern language, do those of the *first* and *second* person carry the distinctions of sex. The reason is obvious (H), namely, that *sex* and

(H) The reason assigned by Mr Harris and his followers is, that “the speaker and hearer being generally present to each other, it would have been superfluous to have marked a distinction by art, which from nature and even dress was commonly apparent on both sides. This is perhaps the best reason which their description of the personal pronouns admits, but it is not satisfactory; for the speaker and hearer may meet in the dark, when different dresses cannot be distinguished.

(I) If we mistake not, Dr Johnson has somewhere affected to ridicule Bishop Lowth for considering the word MINE as the *possessive case* of the *pronoun* of the first person. According to the doctor, MINE is the same word with the pronominal adjective MY; and was anciently used before a vowel, as MY was before a consonant. This is not said with the great Lexicographer’s usual precision. That MINE was anciently used before a vowel is certain; but it does not therefore follow, that it is the same word with MY. If it were, we might on every occasion

Pronouns. That the word ME is the *same* pronoun in the *case* which the Latin grammarians call the *accusative*, is evident from the import of that word in the sentence HE ADMIRES ME, where the *admiration* is supposed to proceed *from* (K) the *person spoken of to the person who speaks*. It appears therefore, that though English *nouns* have only *two cases*, the *nominative* and *possessive*, the *pronouns* of that language have three, as I, MINE, ME; THOU, THINE, THEE; HE, HIS, HIM, &c. That these are cases, can be questioned by no man who admits that *mei, mihi, me*, are cases of the Latin pronoun EGO. Both pronouns, the *Latin* and the *English*, are irregularly inflected: and perhaps those words which are called the oblique cases of each may have originally been derived from nominatives different from EGO and I; but these nominatives are now lost, and *mei* and *mine* have, beyond all dispute, the effect of the genitives of the *Latin* and *English* pronouns of the first person. These variations, however, cannot be looked upon as an essential part of language, but only as a particular refinement invented to prevent the disagreeable repetition of the pronoun, which must frequently have happened without such a contrivance. This seems to have been the only reason why *pronouns* have been endowed with a greater variety of cases than *nouns*. *Nouns* are in themselves greatly diversified. Every *genus* and every *species* of objects has a distinct *name*, and therefore the sameness of sound does not so often occur among them as it would among the *pronouns*, without *cases*, where the same I, THOU, HE, SHE, or IT, answers for every object which occurs in nature: but by this diversity in the form of the words, the *cacophony*, which would be otherwise disgusting, is in a great measure avoided. It is, probably, for the same reason, that the *plural* of each of these pronouns is so very different from the *singular*. Thus from I, MINE, ME, in the *singular*, is formed, in the *plural*, WE, OURS, US; from THOU, THINE, and THEE, YE or YOU, YOURS, YOU; and from HE, SHE, IT, HIS, HERS, ITS, HIM, HER, IT, in the *singular*, THEY, THEIRS, THEM, in the *plural*. In all of which there is not the least resemblance between the *singular* and *plural* of any one word: and except in HE, HIS, HIM; IT, ITS; THEY, THEIRS, THEM; there is not any similarity between the different cases of the same word in the same number.

³⁸
The first and second personal pronouns coalesce with the third.

41. From the account here given of the personal pronouns, it appears that the first or second will, either of them, coalesce with the third, but not with each other. For example, it is good sense, as well as good grammar, to say in any language, I AM HE—THOU ART HE—WE WERE THEY—YOU WERE THEY; but we cannot say—I AM THOU—nor THOU ART I—nor WE ARE YOU, &c. The reason is, there is no absurdity for the *speaker* to be the *subject* also of the discourse, as when it is said—I am he; or for the *person addressed*, as when we say, thou art he. But for the same person, in the same circumstances, to be at once the speaker and the party addressed, is impossible; for which reason the

coalescence of the pronouns of the first and second persons is likewise impossible.

42. I, THOU, HE, SHE, and IT, are all that are usually called *personal* pronouns. There is another class of words, which are called sometimes *pronominal adjectives*, sometimes *adjective pronouns*, sometimes *possessive pronouns*; and by one writer of grammar they have been most absurdly termed *pronominal articles*. It is not worth while to dispute about a name; but the words in question are MY, THY, HER, OUR, YOUR, THEIR. These words are evidently in the *form* of *adjectives*: for, like other English adjectives, they have no variation to indicate either *gender*, *number*, or *case*; and yet they are put in *concord* with *nouns* of every gender and both numbers, as MY WIFE, MY SON, MY BOOK—HER HUSBAND, HER SONS, HER DAUGHTERS, &c. But, though in the *form* of *adjectives*, they have the *power* of the *personal pronouns* in the *possessive case*: MY BOOK is the book of ME, or the book of HIM WHO NOW SPEAKS; OUR HOUSE is the house of US, or the house occupied by the PERSONS WHO NOW SPEAK; HER HUSBAND, is the husband of a woman who can be known only from something preceding in the discourse; and THEIR PROPERTY is the property of them—of any persons, whether men or women, or both, who have been previously mentioned. Words which have the *form* of *adjectives*, with the *power* of *pronouns*, may, without impropriety, be called *pronominal adjectives*; and such is the name by which we shall henceforth distinguish them. To these pronominal adjectives as well as to the personal pronouns, are subjoined the words *own* and *self*—in the plural *selves*: in which case they are emphatical, and imply a silent contrariety or opposition. Thus, I live in my own house; that is, not in a hired house. This I did with my own hand; that is, not by proxy. This was done by myself; that is, not by another. The word *self* subjoined to a personal pronoun forms also the reciprocal pronoun; as we hurt ourselves by vain rage; he blamed himself for his misfortune. *Himself, itself, themselves* are supposed by Wallis to be put, by corruption, for *his self, its self, their selves*; so that *self* is always a *substantive or noun*, and not a pronoun. This seems to be a just observation; for we say, the man came himself; they went themselves; where the words *himself* and *themselves* cannot be accusatives but nominatives, and were anciently written *his self, their selves*.

⁴⁰
The reciprocal pronoun.

There are other words which are usually ranked under the class of *pronouns*: as *who, which, what*. These, when employed in asking questions, are called *interrogative pronouns*; though a name more characteristic might surely be found for them. Their import, however, will be more easily ascertained after we have considered another species of pronouns, which have been denominated *relatives*, and with which they are intimately connected.

43. The pronouns already mentioned may be called *relative prepositive*, as may indeed all substantives, because they are capable of introducing or leading a sentence: noun.

but

occasion substitute either of these for the other, without offending against *grammar*, however we might injure the sound; but we apprehend that this is not the case. "That book is MINE," is good English; but "that book is my" would be a gross solecism: the reason is, that MINE is a *genuine pronoun*, and stands by itself with the *power* of a *noun*; but MY, being an adjective, cannot stand by itself.

(K) See Chap. I. 18, 19. on the Cases of Nouns.

Pronouns. but there is another pronoun which has a character peculiar to itself; and which, as it is never employed but to connect sentences, and must therefore have always a reference to something preceding, is called the *subjunctive*, or *relative* pronoun. This pronoun is in Greek, *ὅς, ἃ, ὅ;* in *Latin*, QUI, QUÆ, QUOD; and in *English*, WHO, WHICH, WHAT.

44. In order to determine with precision the nature and import of the *relative pronoun*, it will be necessary to ascertain the powers which it contains, or the parts of speech into which it is capable of being resolved. Now, it is obvious, that there is not a single noun, or *prepositive pronoun*, which the *relative* is not capable of representing: for we say, I, WHO saw him yesterday, cannot be mistaken; YOU, WHO did not see him, may have been misinformed; THEY, WHO neither saw nor heard, can know nothing of the matter; THE THINGS, WHICH he exhibited, were wonderful. From these examples it is apparent, in the first place, that the *relative* contains in itself the force of any other pronoun; but it contains something more.

45. If from any sentence in which there is a *relative*, that relative be taken away, and the *prepositive* pronoun, which it represents, be substituted in its stead, the sentence will lose its bond of union, and stand quite loose and unconnected. Thus, if instead of saying the man is wise WHO speaks little, we should say the man is wise HE speaks little, the sentence would be resolved into two; and what is affirmed of the man's wisdom, would have no connection with the circumstance of his speaking little. Hence it is evident, in the second place, that the *relative* contains the force of a *connective* as well as of the *prepositive* pronoun. What kind of connection it denotes, is next to be ascertained.

46. It may be laid down as a general principle, "that, by means of the *relative pronoun*, a clause of a sentence, in which there is a verb, is converted into the nature of an adjective, and made to denote some attribute of a substance, or some property or circumstance belonging to the antecedent noun." Thus, when it is said, homo qui prudentia præditus est, the relative clause—qui prudentia præditus est, expresses nothing more than the quality of prudence in concrete with the subject homo, which might have been equally well expressed by the adjective prudens. In like manner, when we say, vir sapit qui pauca loquitur, the relative clause expresses the property of speaking little as belonging to the man, and as being that quality which constitutes, or from which we in-

fer, his wisdom; but if there were such a word as pauciloquens, that quality might very properly be expressed by it, and the phrase vir sapit pauciloquens would express the same assertion with vir sapit qui pauca loquitur.

Now if a relative clause expresses that which might be expressed by an adjective, the presumption is, that it may be resolved into the same constituent parts. But every adjective contains the powers of an abstract substantive, together with an expression of connection; and may be resolved into the *genitive case* of that substantive, or into the *nominative* with the particle of pre-Of the fixed, which, in English, corresponds to the termination same import with the English preposition of. member of a sentence, in which there is a relative, may, in every instance, be analysed in the same manner, will be apparent from the following examples. Vir qui sapit, vir sapiens, and vir sapientiæ; "a man who is wise, a wise man, and a man of wisdom;" are certainly phrases of the same import. Again, homo, cui ingratus est animus, malus fit amicus, may be translated into Greek, ἀνθρώπος ἀκαρτίως κακός γινώσκει φίλος; and into English, "the man of ingratitude is a bad friend."

47. Thus then it appears, that the *relative pronoun* contains in itself the force of the *prepositive* pronoun, together with that connection implied in English by the preposition of, and in the ancient languages by the *genitive case*. When one says vir sapit qui pauca loquitur, the relative clause qui pauca loquitur expresses that attribute of the man from which his wisdom is inferred: it is conceived by the mind, as stripped of its propositional form, and standing in the place of a substantive noun governed in the *genitive case* by vir. The whole sentence might be thus translated, "the man of little speaking is wise;" or, did the use of the English language admit of it, "the man of he speaks little is wise." In like manner, when it is said, "Man who is born of a woman is of few days and full of trouble;"—the relative clause is equivalent to an abstract noun in the *genitive case*, and the whole might be expressed in the following manner, "man of he is born of a woman is of few days and full of trouble."

We are sensible, that these expressions into which, in the instances adduced, we have resolved the relative clauses, will appear extremely uncouth and offensive; but we mean not to recommend them as common modes of phraseology. Against their being employed as such, present use loudly remonstrates (L). They are introduced only with a view to show the true import of the relative.

(L) It is worthy of observation, however, that, repugnant as such expressions are to the present idiom of the English language, there is nothing in the nature of the thing that could render the use of them improper. All prepositions, as will be seen afterwards, are expressive of relations subsisting between these objects of which they connect the signs in discourse. Those objects may be denoted, either by single words, and then the preposition will govern a noun; or by assertions, and then it will govern a nominative and a verb. Thus, when it is said, "I came after his departure;" the preposition after expresses the relation between two events—my coming and his departure, and governs a substantive noun: but if it is said, "I came after he departed," the preposition in this case (for, as shall be shown afterwards, it is absurd to call it, in the one instance, a preposition, and in the other a conjunction) expresses the same relation as before, but governs a nominative and a verb.

This last expression is exactly similar to those employed above. When one says, for example, "the man of he speaks little is wise;"—however uncouth the expression may appear from its not being supported by the authority of custom, the preposition of is used precisely in the same manner, and serves the very same purpose, as when it is said, "the man of little speaking is wise." In both cases it denotes the relation between the two

Pronouns. *relative pronoun*; and for that purpose they are well adapted. That pronoun seems to be of use only when there is a deficiency of *adjectives* or *substantives* to denote some *complex attribute* by which we want to *limit a general term* or *expression*. Where such adjectives or substantives exist in language, we may indeed use the *relative* or not at pleasure. Thus we may say, *homo qui grandia loquitur*, or *homo grandiloquus*; because the *adjective* and the *relative clause* are precisely of the same meaning. But if the Latins were called upon to translate *αὐτοματὸς ἀνελιδιδασίλος*, we believe they must have made use of the *relative pronoun*, as we know not any correspondent adjective in their language.

45
Mr Harris's mistake on this subject.

48. The learned and ingenious Mr Harris has, in his *Treatise on Universal Grammar*, given an analysis of the *relative pronoun* very different from that which has been given by us. The result of his inquiry is, that the *relative* is equivalent to another pronoun, together with an expression of connection of that kind which is denoted by the particle *and*. This analysis he exemplifies, and endeavours to confirm by the following sentence: "Light is a body which moves with great celerity." Now, says he, instead of *which* substitute the words *and it*, and in their united powers you see the force and character of the pronoun here treated. But let any one attentively consider these two expressions,—"*Light is a body which moves with great celerity*,"—and "*Light is a body and it moves with great celerity*;" and he will find that they are not precisely equivalent. For to speak in the language of logic, there is in the *first* but one proposition, of which the *subject* is *light*, and the *predicate* a complex term expressed by the words—*body which moves with great celerity*. In the *second* there are two propositions, or two *predications* concerning light:—*first, that it is a body*; and *secondly, that it moves with great celerity*. The *relative clause*, in the first case, expresses a *property* of the antecedent *body*, which with that property is predicated of the subject *light*; in the second case, this property is removed from the *predicate* of which it was an essential part, and is improperly converted into a new *predication*

of the *subject*. The sentence may be resolved upon our principles, and its precise import preserved; as—"Light is a body of it moves with great celerity"; the clause—"it moves with great celerity," is conceived by the mind as having the force of an *abstract substantive*, and is connected with the antecedent body by the preposition *of*, answering to the termination of the genitive case. This abstract substantive thus connected expresses a *quality of the body* light. But by this example Mr Harris's doctrine is not exhibited in all its absurdity: let us try it by another.

Suppose the following assertion to be true;—"CHARLES XII. was the only monarch who conquered kingdoms to bestow them on his friends." Here it is evident there is but one proposition, of which the predicate is expressed by the words—"only monarch who conquered kingdoms to bestow them on his friends;" so that the *relative clause* is a *necessary part* of the predicate, and has, like an *abstract noun* in the genitive case, the effect of modifying the general term *monarch*. Resolve this sentence on Mr Harris's principles, and you have two propositions of which the first is a notorious falsehood:—"Charles XII. was the only monarch; and he conquered kingdoms to bestow them on his friends." But instead of *and* substitute *of*—saying, "Charles XII. was the only monarch of he conquered kingdoms to bestow them on his friends," and you preserve the true import of the expression (M).

49. Are there no cases, then, in which the relative may be resolved into the connective *and* with a prepositive pronoun? Undoubtedly there are, and we shall now endeavour to ascertain them.

Adjectives in language have two different effects upon the substantives to which they belong, according to the nature of the attribute which they express. If the attribute expressed by the adjective be competent to all the species of which the substantive is the specific name, it is plain that the adjective does not *modify* or *limit* the substantive, for this obvious reason, that nothing can modify which is not discriminative. Thus, when

objects—*man* and *little speaking*; only in the one it is prefixed to a noun, in the other to an assertory clause of a sentence, the import of which is to be taken as a noun. Custom hath indeed determined that prepositions shall more frequently govern a noun than a nominative and a verb; but they are, in their own nature, equally well adapted to answer both purposes.

But, as the *pronoun* of the third person is merely the substitute of some *noun*, an objector may ask, What noun is here represented by *he*? "The man of he speaks little is wise!" Who is meant by the pronoun *he*? We answer, the man who is declared to be *wise*. The objection proceeds from inattention to the radical signification of the word *of*, which a late ingenious writer has shown to be the fragment of a Gothic or Anglo-Saxon word, signifying *consequence* or *offspring*. If this be admitted, and, after the proofs which he has given, we think it cannot be denied, the uncouth phrase, "The man of he speaks little is wise," may be thus resolved, "The man, a consequence (of his mind is) he speaks little, is wise;" or, in other words, "The man, in consequence of his speaking little, is wise." The same acute writer, Mr Horne Tooke, has shown that *of* and *for*, though of different radical meanings, may often be substituted the one for the other without injury to the sense. Let this substitution be made in the present instance, and the propriety of the phrase will be apparent: "The man is wise for he speaks little." It must be remembered, however, that such a substitution cannot be made in every instance, because *for* signifies *cause*, and *of* signifies *consequence*.

(M) Mr Harris was probably led into his opinion, from considering the Latin *qui* or *quis* as compounded of *que* and *is* (see *Hermes*, page 81, 82. edit. 3d.). But the notion of *Perizonius* is perhaps better founded, who in his notes ad *Sanct. Minerv.* considers it as immediately taken from the Greek *τις*, which in the Doric is made *τις*, and in the Latin *quis*. For it seems highly probable, as some ingenious writers have endeavoured to show, that the Latin is a dialect of the Greek. Of this at least we are certain, that many words in the former are immediately adopted from the latter.

Pronouns. When Horace says, "Prata canis albicant pruinis," the adjective *canis* denotes a quality common to all *hoarfrost*; and therefore cannot modify the *substantive*, because it adds nothing to the conception of which that substantive is the name. But when the attribute expressed by the adjective is competent to some *individuals* only of the species of which the substantive is the name, the adjective has then the effect of *modifying* or *limiting* the substantive. Thus, when one says *vir bonus*, he makes use of an adjective which modifies the substantive *vir*, because it expresses a quality or attribute which does not belong to *all men*.

The clause of a sentence, in which there is a *relative*, as it is in every other respect, so is it in this, equivalent to an *adjective*; it either *modifies*, or does not *modify*, the *antecedent*, according as the *attribute* which it expresses is or is not characteristic of the *species* to which the antecedent belongs. Thus, when it is said, "Man, who is born of a woman, is of few days and full of trouble," the relative clause—*who is born of a woman*, expresses an attribute common to *all men*, and therefore cannot modify. In like manner when we say—"SOCRATES, who taught moral philosophy, was virtuous,"—the clause, *who taught moral philosophy*, does not modify. In both these instances the relative clause might be omitted; and it might be said with equal truth, "Man is of few days and full of trouble, —and" "SOCRATES was virtuous."

But if it be said, *vir sapit qui pauca loquitur*, the relative clause—*qui pauca loquitur*, *modifies* the antecedent *vir*; for it is not affirmed of *every man*, that he is wise, but only of *such men as speak little*. So—"Charles XII. was the only monarch who conquered kingdoms to bestow them on his friends;" and, "the man that endureth to the end shall be saved;" with many more examples that will occur to every reader.

Now it will be found, that it is only when the relative clause expresses such a property or circumstance of the antecedent as does *not* limit its signification, that the *relative pronoun* can be resolved into a *prepositive pronoun* with the conjunction *and*, and that in these cases the relative clause itself is of very little importance. Thus in the assertion,—“Charles XII. was the only monarch who conquered kingdoms to bestow them on his friends,”—where the relative clause is *restrictive*, the *who* cannot be resolved into *and he* consistently with truth or common sense. But in the expression, “Man, who is born of a woman, is of few days and full of trouble,” the relative *who* may be so resolved, at least without violating truth;—“Man is of few days and full of trouble, and he is born of a woman.” The only difference between the sentence with the relative *who*, and the same sentence *thus resolved*,—is—that, in the former case, it contains but *one predication*; in the latter *two*, and these but loosely connected.

50. Thus then it appears that the general analysis of the *relative pronoun* is into the particle *of*, and a *prepositive pronoun*; but that there are also occasions on which it may be resolved into a *prepositive pronoun* and the particle *and*, without materially altering the sense. Now what is the reason of this distinction?

If the relative clause be equivalent to an *adjective*, or to an *abstract substantive* in the genitive case, it is easy to see that the relative itself may, in *every instance*, be resolved into another pronoun and the particle *of*; but

VOL. X. Part I.

it will not perhaps be quite so evident how it should in *any instance* be resolved by *and*. This last analysis has its foundation in the nature of the particles *of* and *and*; or, to speak more properly, in the nature of the attribute which the relative clause expresses. Both the particles *of* and *and* are used to link or join conceptions together; but with this difference, that *of* has the effect of making the conceptions it connects figure in the mind as *one object*; whereas the conceptions connected by *and* are still conceived *separately as before*. To explain ourselves by an example: suppose we take two words, *man* and *virtue*, which denote two distinct ideas or conceptions, and join them together by the particle *of*, saying *man of virtue*; the mind no longer views them separately as significant of two conceptions, but of *one*. Take the same words, and join them together by the particle *and*, saying *man and virtue*: the conceptions denoted by *man* and *virtue* are still viewed separately as *two*; notice is only given that they are *collaterally connected*.

This being the case, it follows, that when the relative modifies the antecedent, or, in other words, when the *relative clause* and the *antecedent* denote but *one conception*, the relative must then be resolved by *of*, in order to preserve this *unity of conception*. But when the relative does *not* modify the antecedent; that is, when its clause does not express any *necessary* part of a complex conception, then the conceptions or ideas denoted by the *relative clause* and the *antecedent* may be viewed separately as *two*; and therefore the relative may be resolved into the corresponding prepositive pronoun and the particle *and*.

To state this reasoning in a light somewhat different. As every relative clause, which expresses an attribute that is *not* applicable to a *whole genus* or species, must necessarily *modify* some *general term*, that is, *restrict* its signification; and as that general term must belong either to the *subject* or to the *predicate* of a proposition; it is evident, that every *such* relative clause is a *necessary part* of that *subject* or *predicate* in which its *antecedent* stands. If therefore a relative clause, which *modifies*, be taken *away* either from the *subject* or the *predicate* of a proposition; or if that *connection*, in consequence of which it modifies, be *dissolved* (which is always done when the relative is resolved by *and*); the proposition itself will not hold true. The reason is, that the *subject* or the *predicate* becomes then too general: for, in the *one case*, something is predicated of a *whole genus* or *species*, which can be predicated only of some *individuals* of that genus or species; and in the *other*, a *general predication* is made where only a *particular* one can be applied. Thus, if it be said, “All men who transgress the laws are deserving of punishment;” the *subject* of the proposition is expressed by the words, “all men who transgress the laws.” Take the clause of the relative “who transgress the laws”—away, and say, “all men are deserving of punishment;” and you have a proposition which is not true, because that is affirmed of the *whole species* which can be affirmed only of some *individuals*. Retaining now the clause of the relative, but resolving it by *and*, you have the same proposition as before; and together with it, in this instance, *another* which is equally false:—“All men, *and they* transgress the laws, are deserving of punishment;” that is, “*all men* are deserving of punishment, and *all men* transgress the laws.”

D

But

Pronouns.

But when the attribute expressed by the clause of the relative is characteristic of the *genus* or *species* of the antecedent, and consequently applicable to every individual which that genus or species comprehends, the relative clause may be entirely omitted without affecting the truth of the proposition, which is already as general as it can be. As in this case the import of the relative clause is *not restrictive* of the signification of the antecedent, it is of little consequence whether the attribute be represented by the connective part of the relative, as *of* the antecedent, or be affirmed to belong to the antecedent in a *separate assertion*. Thus it matters not much, whether we say, "Man, who is subject to death, ought not to be too much elated;" that is, according to our analysis, "Man *of* he is subject to death, ought not to be too much elated;" or, forming the relative clause into a separate assertion, and connecting the two by the particle *and*, we say, "Man, and he is subject to death, ought not to be too much elated." In the one sentence, indeed, the *reason* is implied *why* man should not be too much elated, viz. *his being subject to death*: in the other, *no reason* is assigned for this; we only affirm that man is subject to death, and likewise that he should not be too much elated: but as both affirmations are equally true and evident, it is of little consequence in such a case as this, whether the reason upon which either is founded be implied or not.

48
Conclusion
respecting
the relative
pronoun.

51. From the whole of this tedious investigation, we flatter ourselves that the following conclusions are deduced and sufficiently established: 1st, That the *relative pronoun* contains in itself the united powers of a *connective* and *another pronoun*. 2dly, That *of* is the connective of which, together with another *pronoun*, it contains the powers, as in every possible instance it may be resolved into these constituent parts, and the *import* of the sentence in which it has place remain *unaltered*. 3dly, That the relative clause of a sentence has the import of an *abstract substantive*, in the ancient languages, in the *genitive case*; in English, with the particle *of* prefixed. 4thly, That the relative pronoun is of *necessary use* only where there is a deficiency of *adjectives* or *substantives* to denote some *complex attribute*, by which we want to *limit* a *general term* or *expression*; but that where such adjectives or substantives exist in language, we may use the *relative* or not at pleasure. And, 5thly, That though, in cases where the relative clause does not *limit* a *general term*, the relative pronoun may, without *violating truth*, be analysed by *and*; yet such analysis is never proper, as it gives *two predicates* to the same *subject*, which, in the original proposition, had but *one predicate*.

52. If the clause of the relative be equivalent to an adjective, as in every instance it seems to be, it will naturally occur, that in the ancient languages, the relative should agree with its antecedent in *gender*, *number*, and *case*. They do agree for the most part in *gender* and *number*; in *case* they cannot often, because the very intention of introducing a *relative* into language is to represent the antecedent in a *different case*. Whenever we have occasion to use a *substantive* or *noun* in a clause of a sentence, and afterwards to express by

another clause, in which there is a verb, an *attribute* of the object denoted by that *substantive*, we then employ the *relative pronoun*. Now it seldom happens that the two clauses admit of the same *regimen*; and hence the *case* of the relative is often *necessarily different* from that of the antecedent, as the case of each must be accommodated to the clause in which it is found. Thus we cannot say, "Deus *qui* colimus bonus est;" but, "Deus *quem* colimus bonus est;" because the *regimen* of the verb *colō* is always the *accusative*.

This shows the necessity of introducing a relative in- Why the
to those languages which give inflexions to their nouns. relative is
Were all the nouns of a language indeclinable, there more useful
would be little occasion for a relative; and accordingly in the
in English it is often omitted. Examples are frequent learned lan-
in our best authors. Suffice it to quote the following. guages than
in the Eng-
lish.

"For I have *business* would employ an age."

Jane Shore.

"I had several *men* died in my ship of calentures."

SWIFT.

"They who affect to guess at the object they cannot see."

BOLINGBROKE.

We are not ignorant that our most eminent grammarians consider such expressions as chargeable with impropriety; and we are far from recommending them in any dignified or solemn composition. But in the instances adduced there is not the smallest degree of *obscurity*; at least there is none occasioned by the *omission of the relative*. The reason seems to be, that the mind can easily, by an effort of its own, make the *antecedent* unite, first with the one clause, and then with the other. Thus when it is said—"I have *business* would employ an age:" the mind can, without any difficulty, as the word *business* has no inflexions, consider it first as the objective case after *have*, and then as the nominative to *would employ*; but this cannot be so easily done in the ancient languages, where the termination of the noun is changed by the variation of its cases.

53. Both in the learned and in the living languages the relative has different *forms*, corresponding to the different *genders of nouns*; and by these it gives notice whether it is applied to *persons*, or to *things without life*. Thus in the English language we say, *The man or the woman who went to Rome*; *The tree which stands on yonder plain*. It admits likewise, when applied to males or females, a variation of cases similar to that of the *personal pronouns*. Thus we say, *The man whose book is now before me*; *The man or woman whom I saw yesterday*: but the neuter admits of no such distinction (N); as we say *the trees which I saw*, as well as *the trees which stands on yonder plain*. In modern languages the relative admits not of any distinction to denote *number*; for we say, *The man or the men who came yesterday*; *The man or the men of whom I speak*.

54. In English, the word *that*, which by some has The word.
been called a *demonstrative pronoun*, by others a *prono- that often*
minial article, and by us a *definite article*, is often used supplies
instead of the *relative*, as in the following examples: the place of
"He is the same man *that* I saw yesterday:—He was the
the

(N) "Whose is by some authors made the possessive case of *which*, and applied to things as well as persons; I think, improperly." *Leath.*

Pronouns. the ablest prince *that* ever filled a throne." With regard to the principle upon which this acceptation of the word *that* depends, we offer the following conjecture.

51
And why
is done so.

In English, from the cool and phlegmatic arrangement of the language, occasioned by the want of inflexions and conjugations, the place of every part of a sentence is almost uniformly determined, and very little variety is allowed in the collocation of the words. The adjective is almost always placed in apposition with its substantive, and the nominative with its verb. In consequence of this uniformity in the collocation of the words, the mind acquires a habit of connecting in idea any kind of word with the place in which it is used to stand; and is naturally led to consider every word that stands in such a place as belonging to such a class. Hence it is, we imagine, that the definitive *that* passes into the nature of the relative pronoun; as in those instances in which it occupies the place of the relative, it was natural to consider it as having the same import. Yet the word *that* has undoubtedly in itself no more the force of the relative pronoun than *the* or *this*, or any other definitive whatever. In such expressions as the foregoing, it is not improbable that originally the clause of the definitive *that*, which we now call the relative clause, was thrown in as a kind of modifying circumstance in the following manner: "The book (I read that) is elegant;" where the speaker, finding the word *book* too general for his purpose, throws in a clause to qualify and restrict it, or to confine his affirmation to that particular book which he is then reading. We can easily suppose, that through time the definitive *that* in such an expression might be transposed or removed from its own place to that of the relative: so that the expression would run thus, "The book *that* I read is elegant;" which would be considered as precisely equivalent to "The book *which* I read is elegant." This opinion is not a little confirmed by a similar use of the article in Greek, which though undoubtedly a definitive like the English *the*, is often used instead of the relative pronoun. Numberless examples may be found in *Homer* and *Herodotus*, especially in the latter, who seldom uses what is properly called the relative. We shall produce one instance from each.

Εἶπεν Ἀτρεΐδης Ἀγαμέμνονε, ΤΟΝ περὶ πάντων
Ζῶν ὄντων πρῶτον διακρίτης. *Iliad* x. 88.

Ὁμοῖοι γὰρ μεγάλοισι καὶ ταπεινοῖς (Ἀθῆναι σκίλ.) δὲνα
ἴνα κερύεσθαι νομοῖσι ΤΟΥΣ αἰσφῆσι Σάλας ἔλαι, *HEROD. Clis.*

52
Interrogative
pronouns

55. We have said that the *interrogative* pronouns, as they are called, *who*, *which*, *what*, are intimately connected with *relatives*; we now affirm, that the *two first* of these words are *nothing* but relatives, and that the *last* contains in itself the united powers of a *relative* and *definitive*. With respect to *cases*, *number*, and *gender*, the words *who* and *which*, when employed as *interrogatives*, differ not from the same words when employed as *relatives*; and we hold it as a maxim, without which science could not be applied to the subject of language, that the *same word* has always the same *radical import* in whatever different situations it may be placed. To understand this, it is necessary to observe, that all men have a natural propensity to communicate their thoughts in the fewest words possible: hence it follows, that words are often omitted which are necessary to complete the

construction of the sentence; and this nowhere happens more frequently than in the use of *who* and *which*. In sentences where these words are confessedly *relatives*, we often find them without an antecedent; as,

"Who steals my purse steals trash." SHAKESPEARE.

"Which *who* would learn, as soon may tell the sands." DRYDEN.

"Qui *Bavium* non odit, amet tuacarina, *Mævi*. VIRG.

"That is, "He who steals my purse, &c.;" "Which he who would learn, as soon, &c.;" and "Ille qui *Bavium* non odit, &c. Such abbreviations occasion no obscurity, because from previous circumstances the hearer knows the mind of the speaker and the persons to whom he refers. But it is not with respect to the *relative* and *antecedent* only that such abbreviations have place: in sentences of a different form, whole clauses are sometimes omitted, while the meaning of the speaker is made sufficiently plain. Thus when King Richard III. having lost his horse in battle, exclaims,

"A horse! a horse! my kingdom for a horse!"

there is no complete thought *expressed*; but the circumstances in which the king then was, enabled those about him to understand that he *wanted a horse*. Accordingly Catesby answers him,

"Withdraw, my lord, I'll help you to a horse."

In like manner, when a person asks a question, his expression is frequently incomplete; but the tone of his voice, or some other circumstance, enables us to ascertain his meaning, and to supply, if we please, the words that are omitted. Thus when it is said, *An fecisti?* nothing more is *expressed* than *If you did it* (the Latin *an* being nothing else but the Greek *an*, *ei*); but some circumstance enables the person who hears it to know that the meaning is, "Say if you did it." Let us apply these observations to the words *who* and *which*. If these words be *relatives*, and if our analysis of the relative be just, it is obvious, that no *complete* meaning can be contained in the clause, "Who is your principal friend?" for that clause contains nothing more than the circumstance of *being your principal friend* predicated of some *unknown* person; "of he is your principal friend." That this is indeed the case, every man may be convinced, by asking himself what he means by the interrogative *who* in such a sentence; for he will find it impossible to affix to it *any* meaning without supplying an *antecedent clause*, by which that which is called an *interrogative* will be immediately converted into the *relative pronoun*. The custom, however, of language, and the tone of voice with which the *relative clause* is uttered, intimates, without the help of the *antecedent*, the wish of the speaker to be informed by the person addressed of the name and designation of his principal friend; and we know that the sentence when completed is, "Tell me the name and designation of the person who is your principal friend." Again, when the prophet says, "who is this that cometh from Edom, with dyed garments from Bozrah?" he utters but *part* of a sentence, which when completed will run thus: "Describe the person who cometh from Edom (this is that person), with dyed garments from Bozrah." He sees a person coming from Edom, of whose name

53
are merely
relative;
and

Verbs. and designation he is ignorant; he calls upon some one for information concerning these particulars; and that there may be no mistake, he describes the unknown person as having *dyed garments from Bosrah*; but lest even that description should not be sufficiently accurate, he throws in the definitive clause, *this is that person*, pointing at him, we may suppose, with his finger;—*Which*, used as an interrogative, indicates a wish of knowing a particular person or thing out of more than one mentioned; as, “Which of the two did it?” that is, “*Tell me the one of the two which did it?*” for in old English *which* as a *relative* is often used, where in modern English we should say *who*; and that mode of speech is still retained when the antecedent is omitted, and the relative clause employed to indicate such a wish as that before us. *What* includes in itself the signification of a *definitive* and a *relative pronoun*; as, “from *what* has gone before, *what* follows may easily be guessed;” where the word *what* is equivalent to *that which*. When therefore we say, “What rude fellow is that?” our meaning is, “*Describe that person who is that rude fellow.*” Upon the whole, then, it is evident, that the words called *interrogatives* are merely *relative pronouns*; and that interrogative sentences are *relative clauses* uttered in such circumstances as to enable the hearer to supply the antecedents necessary to complete the meaning.

54
interrogative sentences relative clauses.

56. To conclude: We have seen that **SUBSTANTIVES** are either *primary* or *secondary*; or, in other words, **NOUNS** or **PRONOUNS**. **NOUNS** denote *substances*, and those either *natural*, *artificial*, or *abstract*. They moreover denote things either *general*, or *special*, or *particular*; and a *general* or *specific* name is made to denote an *individual* by means of words called *articles* or *definitives*. **PRONOUNS** are the substitutes of **NOUNS**, and are either *prepositive* or *subjunctive*. The **PREPOSITIVE** is distinguished into *three* orders, called the *first*, the *second*, and the *third* person. The **SUBJUNCTIVE**, otherwise called the **RELATIVE**, includes the powers of all those three, having *superadded* as of its own the peculiar force of a *connective*.

CHAP. IV. Of Verbs.

57. THE words which we have hitherto considered are commonly called *substantives* primary or secondary, and *definitives*; because *nouns* are significant of *substances*; *pronouns* are the substitutes of *nouns*; and the *article* serves to ascertain the *extent* of the *noun*, and to determine whether on any occasion it be significant of a whole *class* of substances, or only of *one individual*. But substances are of importance to mankind only on account of their various *qualities* or *attributes*; for their internal texture is a thing of which we are profoundly ignorant, and with which we have no manner of concern. Thus, experience teaches us, that certain vegetables are pleasant to the taste, and wholesome food; whilst others are unpleasant and poisonous. The former kinds are valuable only for their *qualities* or *attributes*; and they are the *qualities* or *attributes* of the latter that make them worthless or hurtful. A horse is strong, and swift, and docile; and may be trained to carry a man on a journey, or to drag a plough. It is for his *strength*, *swiftness*, and *docility*, that he is the most valuable of all quadrupeds. One man is brave,

55
Substances of importance only for their qualities or attributes.

another learned, and another eloquent; and by possessing these different *qualities*, or *attributes*, each is fitted for a different station in society. It is plain, therefore, that in contemplating substances, our attention must be principally bestowed upon their *qualities*, and that the words which serve to denote these qualities must be an essential part of language. Such words are in general called *attributives*; and are of three sorts, *Verbs*, *Participles*, and *Adjectives*.

Verbs. There is a class of words called attributives: These are verbs, participles, and adjectives.

58. Of all the constituent parts of speech none has given the grammarians greater trouble than the **VERB**. The vast variety of circumstances which it blends together in one word, throws very considerable difficulties in the way of him who attempts to analyse it and ascertain its nature; at the same time, that by its eminent use in language, it is intitled to all the attention which can be bestowed upon it. To the discussion of the verb, Mr Harris, whose notions of this as of the other parts of speech have been generally adopted by the subsequent writers on grammar, has dedicated a large proportion of his book, in which he has thrown out many excellent observations, mixed, as it appear to us, with several errors. We have already observed, that no man is ignorant when he uses what is called a *verb* and when a *noun*. Every schoolboy knows, that the words *IS*, *LOVETH*, *WALKETH*, *STANDETH*, in *English*; and *EST*, *AMAT*, *AMATUR*, *AMBULAT*, *STAT*, in *Latin*, are **VERBS**: he knows likewise that they are of different *kinds*; that some of them are said to be *active*, some *passive*, and some *neuter*. But it should seem that the first object of our investigation ought to be the *characteristic* of the verb, or that which all these words have in *common*, and which constitutes them **VERBS**, distinguishing them from *every other species of words*. Now it is obvious to the slightest attention, that every verb, whether *active*, *passive*, or *neuter*, may be resolved into the substantive verb *IS*, and another *attributive*: for *LOVETH* is of the same import with *IS loving*; *WALKETH*, with *IS walking*; and *AMAT*, with *AMANS EST*. But *loving*, *walking*, and *amans*, are not verbs: whence it follows, that the *characteristic* of the verb, that which constitutes it what it is, and cannot be expressed by other words, must be that which is signified by the word *IS*; and to us that appears to be neither more nor less than *assertion*.

57
The difficulty of ascertaining the nature of the verb.

58
The characteristic of the verb.

ASSERTION, therefore, or **PREDICATION**, is certainly the very **ESSENCE** of the *verb*, as being that part of its office, and that part only, which cannot be discharged by other kinds of words. Every other circumstance which the verb includes, such as *attribute*, *mode*, *time*, &c. it may be possible to express by *adjectives*, *participles*, and *adverbs*; but without a *verb* it is impossible to *predicate*, to affirm or deny, any one thing of any other thing. The office of the **VERB**, then, when stripped of all *accidental* circumstances, seems to be merely this, “To join together the subject and predicate of a proposition:” its powers are analogous to those of the sign $+$ in *Algebra*, which does not affect the separate *value* of the quantities between which it is placed, but only indicates their *union* or *coalescence*. To explain by an example: When we say, *Cicero eloquens*, *Cicero wise*; these are imperfect sentences, though they denote a substance and an attribute. The reason is, that they want an *assertion*, to show that such an attribute appertains to such a substance. But when we insert the word *was*,

Verbs. we join the substance and attribute together; we give notice that the *wisdom* and *eloquence* are applied to *Cicero*, and we do nothing more: we neither increase the wisdom nor diminish it, we neither make it real nor imaginary; for it was supposed in all its extent when the words *Cicero* and *wise* stood independent of each other. We may indeed use the *verb* in a form which implies not an *assertion only*, but likewise an *attribute*; as when we say *George writeth*, or *George walketh*: But as *whiteness* or any other particular colour is not of the *essence* of a *horse*, an animal which is found of *all* colours; so in the phrases quoted, the *attribute*, though implied, is not of the *essence* of the *verb*; for it may be equally well expressed by other words: *George is writing*, and *George is walking*, are phrases of the very same import with *George writeth* and *George walketh*.

59. In resolving every verb, whether active, passive, or neuter, into the substantive verb *is* and another attributive, we have the honour to agree with all the grammarians; but to the word *is* itself the learned author of *Hermes* has given a meaning which, as a verb, it does not admit. He observes, that before any thing can be the subject of a proposition, it must *exist*: that all existence is either *absolute* or *qualified*, *mutable* or *immutable*: that the verb *is* can by itself express *absolute existence*, but never the *qualified*, without subjoining the particular form; and that it signifies both *mutable* and *immutable* existence, having in these cases different meanings; although the sentences which he gives as examples are evidently constructed in the same manner and consist of the same parts of speech. His examples are: of *absolute* existence, *B is*; of *qualified*, *B is an animal*; of *mutable*, *This orange is ripe*; of *immutable*, *The diagonal of the square is incommensurable with its sides*. But if *predication* be the essence of verb, all this is nothing to the purpose, and part of it is not true. It is not true that the verb *is* ever varies its signification; for it hath as *verb* no connection with existence of any kind. All such circumstances are superadded to its verbal nature; or, to speak more accurately, we infer such circumstances from our previous knowledge of the objects concerning which the predication is made. When we say, "*this orange is ripe*," we do indeed mean, as Mr Harris observes, that it is *so now at this present* in opposition to *past* and *future* time: but it is not the verb *is*, but the definitive *THIS*, which fixes the *time of maturity*, as well as the *place* of the orange; for had we said *oranges are ripe*, we might have been properly asked, *When and where* are they ripe? although the same verb *is* is used in both sentences. Even in the sentence "*B is*," *absolute* existence (the most simple of all) is *inferred*, and not *expressed*, by the *verb*; and the inference is made from this obvious principle, "That when one utters a mark of *predication*, we naturally conclude that he means to predicate *something* of the subject." If he adds no *specific* predication, as *B is*.

ROUND, we apply to *B* the most general that we can; and what other species is so general as *existence*?

That the idea of existence, considered as *mutable* or *immutable*, is not contained in the verb *is* itself, but is derived from our knowledge of the objects concerning which the predication is made, appears manifestly from this: That if a person be supposed ignorant of the meaning of the words *GOD* and *MAN*, whilst he knows that of *is*; the uttering of the two propositions *God is happy*, and *this man is happy*, will give him no notice of existence considered as *mutable* or *immutable*, *temporary* or *eternal* (o). His conclusion with respect to these modes of existence, if any such conclusion be drawn at all, must be derived entirely from his previous knowledge of the nature of *God* and the nature of *man*.

Some of our readers may possibly think this notion of *verb* too abstract and metaphysical; yet what other circumstance than *mere predication* is essential to that species of words? We say *essential*; for we are here inquiring, not what is expressed by each *individual verb*, but what it is which is equally expressed by *all verbs*, and which distinguishes them from the *other parts of speech*. And if it be true, that every thing which the verb implies, *predication alone excepted*, may be expressed by other parts of speech, and that *no other parts of speech* can predicate; then we think ourselves warranted to affirm, that *simple predication* is the *essential characteristic* of *VERB*; that *every word* which predicates is a *VERB*; and that *nothing* is so which does not predicate.

It must not, however, be concealed, that a doctrine ⁵⁹ very different from this has been lately maintained by ^{An objection to our theory,} a writer of distinguished abilities. "We have *energy* expressed," says Dr Gregory (p), "and of course a verb constituted *without affirmation*, when we wish or command; without *command*, when we affirm or wish; without *wish*, when we command or affirm: yet in all these cases we have equally and indisputably a verb."

That in all these cases we have a *verb*, is indeed indisputable; but we hold it to be equally indisputable, that in all these cases we have *affirmation*. The ingenious author has given no direct example of a *wish* or *command uttered without affirmation*; and a feeling or sentiment which is *not uttered* has nothing to do with language: but he has given a sentence in which there are three verbs, that in his opinion denote *no affirmation*, but a very plain *supposition*. If a *supposition* can be expressed without affirmation, we shall very readily allow that a *wish* or *command* may be so expressed likewise. The Doctor's supposition is thus expressed: "*Had any punishment ever overtaken you for your broken vows; were but one of your teeth growing black, or even were but one of your nails growing less beautiful, I should believe you.*" It is almost superfluous to observe, that to every verb not in the infinitive mode there must be a *nominative*, and to every active verb an *object*, whatever be the arrangement of the sentence in which such verbs are found. These are

(o) The truth of this observation may be proved by experiment, by uttering to a man of good common sense these two propositions, taking care to express the words *God* and *man* in a language which he does not understand. Thus, *Deus is happy*, and *hic homo is happy*; uttered to a man *totally* unacquainted with the Latin tongue, will convey no notice of existence considered as *mutable* or *immutable*, &c.

(p) *THEORY of the MOODS of VERBS*, published in Vol. II. of the *TRANSACTIONS of the ROYAL SOCIETY of EDINBURGH*.

are truths known to every schoolboy; the reasons of them shall be given afterwards. It is likewise undeniable, that in the sentence before us, the nominative to *had* is *any punishment*; to the first, *were one of your teeth*; and to the second, *one of your nails*. But the sentence arranged in grammatical order, with the several nominatives before their respective verbs, is evidently *elliptical*; and the conjunction *if* must be supplied as well to complete the construction as to make sense of the passage. *If* any punishment had ever overtaken you; *if* but one of your teeth were growing black, or even *if* but one of your nails were growing less beautiful, I should believe you." Now it has lately been proved, by such evidence as leaves no room for doubt, that *if*, though called a *conjunction*, is in fact a *verb* in the imperative mode, of the same import with *give*; so that we may substitute the one for the other without in the smallest degree altering the sense. The sentence will then run thus: "Give any punishment had ever overtaken you; *give* but one of your teeth were growing black, &c. I should believe you." It is therefore so far from being true, that *had* and *were*, when the sentence is completed, express no affirmation; that it is only upon *granting the truth of the affirmation which they denote*, that the speaker says, "I should believe you." "Any punishment had ever overtaken you," is plainly an affirmation; *if, give* that affirmation, *admit its truth*, "I should believe you." But it cannot be supposed that *had* and *were* change their significations by a mere change of place, or that by being removed from the *middle* to the *beginning* of a clause, they *lose* their *original import*, and come to denote something *entirely different*. Were this the case, every attempt to ascertain and fix the general principles of grammar would be as ridiculous as an attempt to arrest the course of time. For what purpose then, it may be asked, if the verb *always* denotes *affirmation*, is it removed from the middle to the beginning of the clause, when *supposition* is implied as in the present instance? We answer, that *supposition* is neither more nor less than *conditional affirmation*; that when *such* affirmation is *completely* expressed, the verb is *not* removed to the beginning of the clause; and that such removal takes place *only* when the clause is *elliptical*, being merely an artificial contrivance in language, to show the reader or bearer that some such word, as *if*, demanding the truth of the affirmation, is *omitted* for the sake of dispatch. This is evident; for when the word requiring the affirmation to be granted is *supplied*, the verb must be restored to its place in the middle of the clause. Such abbreviations, and such contrivances to mark them, are frequent in all languages, as will be seen more clearly when we come to treat of modes.

Upon the whole, notwithstanding the deference which we willingly pay to this very masterly writer, we are compelled reluctantly to differ from him, and still to think that *simple predication is the essence of the VERB*.

Should we be required to exemplify our theory by language, and to produce instances of this simplified verb in practice, we might answer, that the not being able to produce such instances would be no good argument against the truth of our principles. It is the nature of language to express many circumstances by the same word, all of which however are not *essential* to distinguish the *species* to which that word belongs from the *other species* of words; and it is the nature of man to *infer* from discourse many things which are not *actually expressed*. Perhaps, however, something nearly approaching to an exemplification of our idea of a *simple verb* will be found in the following proposition: "The three angles of every plane triangle are equal to two right angles." What other office the verb *are* here performs than simply to join the *subject* and *predicate*, it is difficult to perceive. It does not give notice of *time*; or such notice, if given, is an imperfection; for the truth of the proposition is independent on time. Neither ought it to imply *existence*; for the proposition would be true, were there neither a triangle nor a right angle in nature.

This idea of *verb*, when it is well considered, we hope will be found just; but should any of our readers suspect it of novelty, and on that account be disposed to condemn it, we have only to request that he will restrain his censure till he has examined the writings of others, and nicely observed the several postures of his own mind in discourse; for meditation may perhaps show him that our theory is not false, and inquiry will satisfy him that it is not novel (Q).

60. But although it is certain that *assertion*, and *as-* The greater part of that species of words which grammarians call *verbs* denote an attribute as well as an *assertion*; or, in the language of *logic*, they express both the *copula* and the *predicate* of a proposition: thus, *he liveth, he writeth, he walketh*, are phrases equivalent in all respects to—*he is living, he is writing, he is walking*. Now, of attributes *some* have their essence in *motion*, as *walking*; *some* in the *privation of motion*, as *resting*; and *others* have *nothing to do with either motion or its privation*, as *white* and *black*. But all *motion* and all *privation of motion* imply *time* as their *concomitant*; and a *substance* may have an *attribute to-day* which it had *not yesterday*, and will not have *to-morrow*. This is self-evident; for a man may be at rest *to-day* who *yesterday* was *walking*; and *to-morrow* will be on *horseback*; and a sheet of paper may have been *white* yesterday, which *to-day* is *black*.

(Q) "Besides words, which are names of ideas in the mind, there are a great many others that are made use of, to signify the *connection* that the mind gives to ideas or propositions one with another. The mind in communicating its thoughts to others, does not only need *signs* of the *ideas* it has then before it, but *others* also to show or intimate some particular *action* of its own at that time *relating* to those ideas. This it does several ways; as *is* and *is not* are the general *marks* of the mind *affirming* or *denying*." *Locks on Human Understanding*.

"Verbum est pars orationis variabilis, aliquid de re aliqua dici seu affirmari significans. Vulgaris verbi definitio est, quod, sit pars orationis, quæ agere, pati, aut esse significet. Sed nostra accuratior, magisque ex ipsa verbi cujusvis natura petita videtur. Cæterum *affirmari* laxiore hic sensu accipimus, pro eo quod prædicari Dialectici appellant, quo non modo affirmationes strictius sic dicuntur, sed negationes etiam interrogationesque includuntur." *Ruddimanni Grammaticæ Institutiones*. See also *Dr Beattie's Theory of Language*.

Verbs.
63
All verbs denote time: hence the origin of tenses.

black, and at some future time will be of a different colour. As, therefore, all motions and their privation imply time: and as a proposition may be true, at one time, which is not true at another; all VERBS, as well those which denote both an attribute and an assertion, as those which denote an assertion only, come to denote TIME also: Hence the origin and use of tenses, which are so many different forms assigned to each verb, to show, without altering its principal signification, the various TIMES in which the assertion expressed by it may be true. Whether these various forms of the verb be essential to language, it is vain to dispute. They have place in every language with which we are acquainted; and as the use of the verb is to affirm one thing of another, it is absolutely necessary that the time, when such or such an affirmation is true, be marked by tenses, or some other contrivance. Concerning tenses, therefore, we shall throw together some observations equally applicable to every language, after premising a general remark or two which seem necessary in order to proceed with precision.

64
All time past, present, or future; hence the tenses of verbs are threefold.

61. Time, although its essence consists in succession continued and unbroken, may yet be considered by the mind as divided into an infinite number of parts. There is, however, one grand division which necessarily occurs, and to which the different tenses of verbs are in all languages adapted.—Computing from some portion conceived to be present, all time is either past or to come. Hence the tenses of verbs are threefold; some denoting time present, some time past, and others time future.

Again, from the very nature of time, it must be obvious, that all its parts are relative; i. e. that no portion of it can be ascertained by any thing inherent in itself, but only by referring it to some other portion, with respect to which it is past, present, or to come. In this respect time is perfectly analogous to space: for as the space in which any object exists, cannot be described but by stating its relation to some other space; so neither can the time of any attribute or action be determined, but by stating its relation to some other time. When, therefore, we would mark the time of any action or event, we must previously fix upon some point to which we may refer it. If this point be known, the time referred to it will be known also; but if the former be not known, neither will the latter.

Lastly, in contemplating an action, we may have occasion to consider it as going on, or as finished. This distinction is likewise denoted by the different tenses of verbs. In treating, therefore, of the tenses, there are two things to which attention ought principally to be turned;—the relation which the several tenses have to one another in respect of time; and the notice which they give of an action's being completed or not completed.

65
Different grammars have enumerated different numbers of tenses.

62. Having premised these remarks, we proceed now to the tenses themselves; of which Mr HARRIS has enumerated no fewer than twelve. Of this enumeration we can by no means approve; for, without entering into a minute examination of it, nothing can be more obvious, than that his INCEPTIVE PRESENT—I am going to write—is a FUTURE TENSE; and his COMPLETIVE PRESENT—I have written—a PAST tense. But, as was before observed of the classification of words, we cannot help being of opinion, that, to take the tenses as they are commonly received, and endeavour to ascertain their nature and their differences, is a much more useful exercise, as well as more proper for a work of

this kind, than to raise, as might easily be done, new and hypothetical theories on the subject.

Verbs.

It has been already observed, that all the tenses must necessarily mark relative time. In one sense, this is extremely obvious. The present tense is used in contradistinction to both the past and future, and marks an attribute or action as existing in neither. The past and the future are in like manner used in contradistinction to the present; and mark an attribute or action which exists not now, but which in the one case has existed formerly, in the other will exist at some time coming. But besides this relation of contradistinction subsisting among the tenses, there is another of co-existence, as we may call it, to which it is of great consequence to attend—especially in examining the nature of the present.

66
Of the present tense.

63. The PRESENT TENSE refers not only to something which is past or future, but also to something with which the attribute or action of the verb is contemporary. This reference is necessarily implied in its very name; for we cannot say of any thing that it is present, without implying at the same time that there is something else with which it is present. Hence it appears with how little reason Mr Harris and others have given us an *arist* of the present, as marking present time indefinitely in contradistinction to OTHER presents, which have been called *inceptive*, *extended*, and *completive presents*. For from what has been said it follows, that the present tense is necessarily and from its very nature perfectly indefinite, and can of itself give notice of no precise or determinate portion or point of time whatever. A thing may have been present fifty years ago, may be present now, or at any future period. This tense implies the relation of co-existence between two or more things; but, without some auxiliary circumstance, it cannot in any language mark the particular portion of time in which those things exist. The indefinite nature of this tense is indeed most clearly seen in that use of it in which Mr Harris has styled it the *arist* of the present; that is, in cases where it is employed to denote the repetition of an action which the agent is accustomed frequently to perform, or to express propositions of which the truth is evinced by general experience; as in the following examples:

“Hypocrisy—the only evil that walks
“Invisible, except to God alone.”

“Ad poenitendum propter qui cito judicat,” &c.

In these instances it is plain there is no particular time pointed out: the propositions are true, or apprehended as true, at all times. Although the actions, therefore, of walking and hastening are expressed as present, it is impossible from the expressions to determine any precise point of time when they are present.

But if the present tense be thus indefinite, how, it may be asked, are we to ascertain the particular time which is intended? We answer, it is to be ascertained, either by stating the action of the verb as existing in some time already known, or by inference. If, for example, we say,—“Millions of spiritual creatures walk the earth unseen,”—the proposition is general, and the time of walking undetermined. But if we add—“both when we wake and when we sleep,”—the time is by this addition ascertained and specified; for if the time when men wake and sleep be known, the time when these spirits walk the earth is known also.—When no specifying clause is given by which to determine the time of the present tense, it is very commonly determined by inference.

Verbs. *ference.* Thus, if one use such an expression as—"He sleeps while I am speaking to him,"—the time of his sleeping is ascertained by the subsequent clause of the sentence; but if it be said simply—"he sleeps"—without assigning any data from which it may be concluded when his sleeping is present, we very naturally infer that it is at the instant we receive the information of his sleeping. Such inferences as this are common in language. The mind is desirous to obtain complete information on every subject; and therefore frequently supplies to itself what is not expressed in the speech of others.

Both these ways of ascertaining the precise time of the present tense, are excellently illustrated by the use of the word present as applied to space. Take a familiar example:—"His brother and he were present when I read the letter." It is at first sight evident that this expression is perfectly indefinite. But if it be said—"His brother and he were present at your house when I read the letter,"—the place of action is then determined by being referred to a portion of space which is known. If no such reference be made, the person who hears the speech uttered must either remain ignorant of the place intended, or he must ascertain it to himself by inference; and he will probably infer it to be that in which the speaker is at the time of his uttering the indefinite sentence. This leads us to observe, that such inferences are not often made without sufficient foundation. Various circumstances may assist the reader or hearer in making them, and prevent all danger of mistake. He may have the evidence of sense, or of something preceding in the discourse, and a number of other particulars, to justify and warrant his conclusion. Thus, if when sitting by a large fire, one pronounce the words—"I am too warm;" those to whom he addresses his speech are authorized to conclude, that he is too warm at the time of speaking, unless he expressly prevent the drawing of that conclusion by adding some such clause as—"When I wear a great coat."

It is strictly demonstrable, and hath by Mr Harris been in fact demonstrated, that there is no such thing as present time. Yet do we not only conceive time as present and existing, but frequently as extended to a very great degree. We speak not only of the present instant, or the present day, but also of the present year, and even of the present century. This manner of conceiving time is indeed loose and unphilosophical; but it is sufficient for the ordinary purposes of language. To express time as it really is, we ought to say, the passing day, the passing year, and the passing century; but in common discourse we denominate any portion of time present, in which the present now or instant is included, although it is obvious that part of that portion is past, and the remainder of it future. From the very nature of time thus conceived to be present, the tense now under consideration must represent the action of the verb as commenced, and not finished: for as time is in continued succession, and accompanies every action; when any action is not commenced, it exists not in any time, though it may exist hereafter in time which is now future; and when it is finished, it exists no longer in time present, but in time past. Hence the absurdity of introducing into a theory of the tenses an inceptive present and a completive present; for these terms imply each a direct contradiction.

64. After having said so much of the present tense, we shall have but little to say of the PRÆTER-IMPERFECT. It states an action in respect of time as past; and in respect of progress, as unfinished. *Legebam*—I was reading at some past time, but my reading was then incomplete; I had not finished the book or the letter. We must here observe, however, as we did with respect to the present tense, that although the præter-imperfect represents the action as past, it does not inform us in what precise portion of past time the unfinished action was going on: this circumstance must either be given in separate words, or be inferred by the hearer. If one say simply—*Legebam*, the person to whom he addresses his speech will conclude, that the time of his reading is past with respect to the present time of his speaking. But if he say,—*Legebam antequam venisti*, he expressly states the action of reading as past with respect to the time in which his hearer came to the place where they both are at the time of speaking. The time of the præter-imperfect is always past with respect to the present instant when the imperfect is used, and of this the tense itself gives notice; but it may also be past with respect to some other time, and of this it conveys no information.

If we join two præter-imperfects together, the expression will state the co-existence of two progressive actions, both of which were going on at a time past in respect of some determinate time given or supposed. "*Cum tu scribebas ego legebam*;" "when you were writing I was reading." Hence the præter-imperfect has by some grammarians been called the relative present; a name which, however, is by no means exclusively applicable to this tense. When the præter-imperfect is by the conjunction and joined in the same sentence with a plusquam-perfect, the two tenses express two actions, both prior to the time of speaking; but the one as having continued after the other was finished. Thus, *Eneas* speaking of the destruction of Troy, says, that after having escaped with his father and followers, he returned to the city in quest of his wife, and went directly to his own house; but there, continues he, "*irruerant Danaï, et tectum omne tenebant*."—"the Greeks had rushed in," that action was over and completed before his arrival; but the act of "possessing the whole house," *tenebant*, was not over, but still continuing.

65. But it is necessary that the verb denote actions which were complete or perfect in past time, as well as those which were incomplete or imperfect. For this purpose, Greek and English verbs have an aorist, a præter-perfect, and a plusquam-perfect. Of these the Latin has only the two last. The præter-perfect in that language sustains a twofold character: it performs the office of the Greek and English aorist, as well as of the præter-perfect properly so called; that is, it denotes a finished action at some indefinite past time, as well as at some time which is both past and definite.

In attempting to analyze the signification of complex terms, by which we here mean words that include in their signification a variety of particulars, it is of great advantage to have these particulars separately expressed by different words in another language. Now the English has resolved the tenses, which in the Greek and Latin languages are denominated the aorist and the præter-perfect, by means of what are commonly called auxiliary verbs, expressing the former by the verb *did*, and the latter by the verb *have*. In examining there-

fore

Verba. fore the *aorist* and *præter-perfect*, it will be of use to inquire into the import of *these verbs*.

Did is evidently the *aorist* of the verb *to do*; a verb of the most general signification, as it denotes *action of every kind*. It expresses the *finished performance of some action*, the completion of which must of course have taken place in some portion of *past time*. "*I DID write, or I wrote* (these expressions being equivalent) yesterday, a month, a year ago," &c. But the import of *did* being so very general, it can convey no *determinate* meaning without being limited by the addition of some *particular action*; and this *addition*, however expressed, is to be considered in the same light as an *accusative case*, governed by the active verb *did*; for it produces exactly the same *effect*. "*ἔγραψα, scripsi, I did WRITE*; that is, "*at some past time I performed the action of writing, and finished it.*"

The verb *have*, which is included in the *præter-perfect*, is plainly a verb of the *present tense* denoting *possession*. But a man may possess *one* thing as well as *another*; and therefore *have* requires *limitation*, for the very same reason that *did* requires it, namely, because its signification is *perfectly general*. Now this *limitation*, whatever it is, must be conceived as the *thing possessed*; and in instances where *have* is limited by a *noun*, this is obvious, and universally acknowledged: "*I have a gold watch,*" is, "*I possess a gold watch.*" But to annex the same meaning to the word *have*, when used as an *auxiliary verb*, is an idea we believe not common, and which may perhaps be thought whimsical; yet what other meaning *can* be affixed to it? To suppose that words have not each a *radical* and *determinate* signification, is to suppose language a subject incapable of philosophical investigation; and to suppose, with Mr *Harris*, that there are words entirely *devoid* of signification, is at once to render all inquiries after the principles of grammar nugatory and ridiculous. We conceive, then, that each of the phrases, "*ἔγραψα ἑπιστολὴν, scripsi epistolam, I HAVE written a letter,*" is equivalent to the phrase, "*I possess at present the finished action of writing a letter.*" Such an expression may sound *harsh* to the ear, because it is *not in use*: but we often employ expressions, to the *precise* and *proper* meaning of which we do not attend; and if the above be attentively considered, however awkward it may at first appear, nothing will be found in it either improper or absurd.

The *aorist*, then, we conceive to state an action as *performed* and *finished* in some *past portion of time*; whilst the *præter-perfect* represents the *past performance* and *completion* of that action as *now possessed*. And here we may hazard a conjecture why *have*, when used as an auxiliary verb, is always joined with a *past participle*; whereas *did* is joined to a word expressing the *simple action* of the verb, or, as it is called, *present infinitive*. Of the expression, "*I have WRITTEN a letter,*" as *one part*, viz. the verb *have*, denotes *present time*; the other part, viz. WRITTEN, must denote *past time*, to give notice that the action is *performed* and *finished*. *Did*, on the other hand, implying *past time*, has no occasion for the *past part* of another verb to give notice of this circumstance; for "*I did WRITE a letter,*" is equivalent to, "*at some past time I performed and finished the simple action of writing a letter.*"

The principal distinction in practice between the *aorist* and *præter-perfect* (for the difference seems little in their real import) consists in the *time* by which the performance of the action admits of being *particularly* specified. The *præter-perfect* is always joined with a portion of time which includes the *present now* or *instant*; for otherwise it could not signify, as it always does, the *present possession* of the *finishing* of an action.

But the *aorist*, which signifies *no such possession*, is as constantly joined with a portion of *past time* which excludes the *present now* or *instant*. Thus we say, "*I have written a letter this day, this week,*" &c.; but, "*I wrote a letter yesterday, last week,*" &c.; and to *interchange* these expressions of time in *Greek* and *English*, where the *aorist* and *præter-perfect* have different forms, would be improper. In *Latin*, indeed, where they have but one form, the impropriety does not appear.

66. Besides the tenses already examined, which are expressive of *past time*, in most languages the verb has another tense called the *plusquam-perfect*, in which, however, no difficulty occurs to detain our attention. What the *præter-imperfect* is to the *present tense*, that the *plusquam-perfect* is to the *præter-perfect*. The verb *had*, by which it is resolved in *English*, being evidently the past time of *have*, sufficiently explains its meaning and relation to the other tenses: "*I had written a letter,*" is equivalent to the phrase, "*I possessed at some past time, the finished action of writing a letter.*"

It is justly observed by *Dr Beattie*, that the imperfect and plusquam-perfect are very useful, and may be the sources of much elegant expression; and that if one were not taught to distinguish, in respect of meaning as well as of form, these tenses from each other, and the *præterite* from both, one could not pretend to understand, far less to translate, any good classic author.

67. Having considered the tenses which imply *present* and *past time*, it now remains that we examine the import of those which are expressive of *time future*. In *Latin* and *English* there are *two tenses* for this purpose; of which the *first* represents an action in point of *time as not yet existing*, but as about to exist at some period *to come*; but it does not bring the *completion* of the action into view. The *other* asserts the *futurity* of an action together with its *completion*. *Scribam*, "*I shall be writing,*" denotes *future time* and *complete action*; for it does not say whether I am to write for a long or for a short time, or whether I shall *finish* what I promised to *begin*. This part of the verb, therefore, to which the Greek *ἔσω* corresponds, is an *imperfect future*, and likewise an *aorist*. The futurity of any action, it should seem, may always be computed from the time of speaking; for every action must be *future* with respect to the *time* at which its futurity is *declared*; but the *time* of its futurity may be more precisely specified by fixing on some *other future time* to which to refer it: "*I shall be writing after he shall have departed.*" *Shall* or *will* refers to future *time indefinitely*; and *write* or *writing* refers to an action which is intended to *begin* and so far to proceed, but of which nothing is said concerning the completion.

On the other hand, *scripsero*, "*I shall have written,*" is a *perfect future* denoting complete action; for *shall* denotes *future time*; *written*, *finished action*; and *have*, *present possession*. So that the meaning of the whole assertion

Verbs.

is, that "at some future period of time I shall possess the finished action of writing." The completion of the action, together with the possession of it, is always future with respect to the time of assertion; but, with respect to some other time expressed or understood, the completion of the action is to be past: *Promittis te scripturum si rogavero*, "you promise to write if I shall have asked you." In this sentence the action of asking is future with relation to the time of promising, but it is past with relation to that of writing. This tense the Latin grammarians call the future of the subjunctive mode; but very improperly. The notice which it communicates, respects not the power or liberty of acting, which, as will be seen by and by, is the characteristic of that mode; but the action itself. It ought therefore to be ranked among the tenses of the indicative mode; for scripsero is, in every sense, as really indicative as scribam or scripturus ero.

72
Of the tenses of the subjunctive mode.

68. These are all the tenses, essentially different from each other, which have place in the indicative mode of any language with which we are acquainted (R); but as there are tenses in the mode called Subjunctive, which bear the same names with these already examined, and which have yet a different import, it will be necessary to consider them before we dismiss the subject of tenses.

Of modes in general something must be said hereafter; at present we shall only observe, that the mode with which we are now concerned, is not very properly distinguished by the name assigned to it by the Latin grammarians. They call it the subjunctive, because it is often subjoined to another verb, and forms the secondary clause of a sentence: but the mode called indicative frequently appears in the same circumstances. The difference between these two modes appears to us to consist in this, that the indicative asserts something directly concerning the action; the subjunctive, something concerning the power or liberty of the agent to perform it: for that the latter asserts as well as the former, admits not of dispute.

73
The present.

69. The present tense of the subjunctive mode, in the learned languages, answers to the English auxiliaries may and can. Let us consider these a little.—May is evidently a verb of the present tense denoting liberty. When I assert that I MAY write, I give notice that "I am under no compulsion to abstain from writing;" that there is no impediment from without by which I am restrained from writing. Can is also a verb of the present

tense, expressive of internal power or skill. "I can write" is equivalent to—"There is nothing in myself which incapacitates me for performing the operation of writing." This verb seems originally to have denoted knowledge or skill, and to have been afterwards extended to signify power or ability of any kind. There is little doubt of its being the same with the old English verb to con, which signifies to know.—The difference between the import of these two verbs may and can will be best perceived in a familiar example. Suppose we say to one of our transcribers, "You may write a treatise on grammar, to which he returns for answer "I cannot:" our assertion evidently supposes him at liberty to write the treatise; his answer implies, that he is unable or unskilled to do it. We may conclude, then, that the present tense of this mode contains a declaration of present liberty, ability, or skill; and its other tenses will be found to have reference to the same capacities.

Verbs.

The observation is here to be repeated which was enlarged upon under the present of the indicative. The liberty or ability signified by this tense is always represented as present; but the time of this presence is indefinite. If no particular time be specified, we generally refer it to the time of speaking; but another point may be given from which we are to compute. "When he shall have finished, you may then proceed as you propose." Here the liberty of proceeding is stated as present, not at the time of speaking, but at the time of his finishing, which is future to the time of speaking. But though the liberty, ability, or skill, denoted by this tense, be represented as present, the action itself is stated as contingent; for it is not necessary that a man should perform an action because he has the capacity to perform it.

From this idea of the present of the subjunctive some of its most peculiar uses seem capable of being explained.—And, in the first place, it appears to have a near affinity with the future of the indicative; inso much that in many instances they may be used promiscuously. Without materially altering the effect of the expression, we may say, "Dico me facturum esse quæ imperet," or "quæ imperabit." The reason of this, perhaps, may be, that with respect to us, futurity and contingency are in most cases nearly the same, both being involved in equal obscurity; and therefore it is often of little consequence which mode of expression we employ.

Secondly, The present of the subjunctive is used to denote

(R) On this point we subscribe to the opinion of the elegant and ingenious Dr Beattie.—"It will perhaps occur (says he), that there are two Greek tenses, of which I have given no account; namely, the second aorist, and the second future. The truth is, that I consider them as unnecessary. Their place, for any thing I know to the contrary, might at all times be supplied by the first aorist and the first future. Some grammarians are of opinion, that the first aorist signifies time past in general, and the second, indefinite time past; and that the first future denotes a nearer, and the second, a more remote, futurity. But this, I apprehend, is mere conjecture, unsupported by proof: and therefore I incline rather to the sentiments of those who teach, that the second future and the second aorist have no meaning different from the first future and the first aorist; and that they are the present and imperfect of some obsolete theme of the verb; and when the other theme came into use, happened to be retained for the sake of variety perhaps, or by accident, with a preterite and future signification. Be this as it will, as these tenses are peculiar to the Greek, and have nothing corresponding to them in other tongues, we need not scruple to overlook them as superfluous."—*The Theory of Language*, Part II. Chap. ii.

To these judicious observations we have nothing to add, but that they acquire no small degree of confirmation from this circumstance, that there are many Greek verbs which have no second future, and which are yet employed to denote every possible modification of future time. Of the paulo-post-futurum of the Greeks we have taken

Verbs. note the *right* of which a person is possessed. "I may, or I can, sell this book." This application, which Dr Priestley considers as the *primary* signification of the tense, is easily deduced, or rather follows immediately, from the foregoing account of its import. For if one be under *no restraint*, either external or internal, to prevent him from performing an action, he has surely a *right* to perform it.

the *subjunctive* of the verb *do*; for it is nonsense to talk of *liberty*, with respect to the *performance* of an action, which, at the time of speaking, is supposed to be *past* and *completed*. What then is the import of the phrase? We are persuaded that it is elliptical, and that the word *say* or *affirm* is understood: "I may (say that I) have done such or such a thing in my time;" for liberty or contingency can relate to actions only as they are conceived to be *present* or *future*.

Verbs.

Thirdly, The *present* of the *subjunctive* is often used to signify *command* or *request*; as when one says, "You may give my compliments to such a person." This use of the tense under consideration seems to have arisen from a desire to *soften the harshness* of a command, by avoiding the appearance of claiming superiority. When a man utters the above sentence, he certainly utters *no command*, but only *asserts* that the person to whom he speaks has *liberty* or *power* to do him a favour. This assertion, however, may contain no *new information*; and therefore the person *addressed*, reflecting upon the *intention* of the *speaker* in making it, infers that it indicates a *wish* or *desire* that "his compliments should be made to such a person."

72. Of all the tenses, the most complex is the *plus-quam-perfect* of this mode. It combines a *past* and a *quam-perfect* time with a *finished* action. It may be considered as the *past time* both of the *perfect future* and of the *preter-perfect* of the *subjunctive*: for it represents an action, *future* and *contingent* at some *past time*, as *finished before* another *period specified*; which period therefore, though *past* at the *time of speaking*, was itself *future* with respect to the time when the futurity or contingency of the *action existed*. "Promisisti te scripturum fuisse si rogassem;" "You promised that you would write, if I should have asked you." Here the *futurity* of the action of *asking*, which is represented as *complete* and *finished*, is stated as *co-existing* with the *past promise*; but the *action itself* must be *posterior* to that promise: it is however supposed to be *past* with respect to the action of *writing*, which is also *posterior* to the promise.

74
The preter-imperfect.

70. Of the *subjunctive* as well as of the *indicative*, the *preter-imperfect* is evidently the *past time* of the *present*. As the latter asserts *liberty*, or *ability*, to perform some action, as existing at *present*, the former asserts the same liberty or ability to *have existed* in *time past*; but the *precise portion* of time past, in which these capacities existed, must be specified by other words, or it will remain *unknown*. Thus in the following sentence, "Dixi me facturum esse quæ imperaret," the time of *imperaret* is referred to that of *dixi*: the person having the *right* to command, is supposed to have had it at the *time* when the other *said* that he would *obey*. This tense, as well as the present, states the action as *going on* and *incomplete*; and also as *future* with respect to the *liberty* or *ability* to perform it. It is rendered into *English* by the verbs *could* or *might*; of which the *first* is the past time of *can*, the second of *may*.

73. Before we dismiss the subject of tenses, it may be said to be improper just to mention *number* and *person*; for these have place in every tense of the verb in the *learned* languages, and in many tenses even of the *English* verb. They cannot, however, be deemed *essential* to the verb; for *affirmation* is the same, whether it be made by *you*, by *me*, or by a *third person*, or whether it be made by *one man* or by a *thousand*. The most that can be said is, that verbs in the more elegant languages are provided with a variety of terminations which respect the *number* and *person* of every *substantive*, that we may know with more precision, in a complex sentence, each particular substance with its attendant verbal attributes. The same may be said of *sex* with respect to *adjectives*. They have terminations which *vary* as they respect beings *male* or *female*, though it is past dispute that *substances alone* are susceptible of *sex*. We therefore pass over these matters, and all of like kind, as being rather among the *elegancies* of *particular languages*, and therefore to be learned from the *particular grammar* of each tongue, than among the *essentials* of language; which *essentials alone* are the subject of inquiry in a treatise on *universal grammar*.

75
The preter-perfect.

From the near affinity which the *present* of the *subjunctive* has to the *future* of the *indicative*, the tense now under consideration appears, in many instances, as the past time of the *latter* as well as the *former*. Thus *Disi me facturum quæ imperaret*, may be rendered "I said that I would do whatever he might, or whatever he *should*, command."

71. Of the *preter-perfect*, it is sufficient to observe, that as the *present* states the agent as at *liberty* to be performing an *unfinished* action; so this tense states him as at *liberty* to perform the action considered as *finished*. "I may be writing a letter when you come, i. e. I am at liberty to be writing a letter when you come." I may have written a letter when you come," i. e. I am at liberty to be in possession of the *finished* action of writing a letter when you come."

74. Besides *tenses*, *number*, and *person*, in every tongue Of *modes*. with which we are acquainted, *verbs* are subject to another variation, which grammarians have agreed to call *Modes*. Of *modes*, as of *tenses*, it has been warmly disputed whether or not they be essential to language. The truth seems to be, that the only part of the verb *absolutely necessary* for the purpose of communicating thought is the *indicative mode*; for all the others, as has been well observed by Dr Gregory, are resolvable, by means of additional verbs and a word denoting the action of the primary verb, into circuitous expressions which

It is a common mode of expression to say, "I may have done such or such a thing in my time," when he who speaks can have little doubt whether he has done the thing or not. In that case, the words *may have done*, cannot be considered as the *preter-perfect* of

E 2

taken no notice, because it is found only in the *passive* voice; to which, if it were necessary, it is obvious that it would be necessary in *all* voices, as a man may be about to *act* as well as to *suffer* immediately.

Verbs.
79
Different
opinions
about the
number of
modes.

which fully convey their meaning (s). But such expressions continually repeated would make language very prolix and wholly inanimated; for which reason, the import of each of the commonly received modes is a subject worthy of the philologist's investigation. About the number of modes, whether necessary or only expedient, as well as about the import of each, the writers on grammar have differed in opinion. Mr Harris, one of the most celebrated of those writers, has enumerated four modes of the verb, besides the infinitive; viz. The INDICATIVE or DECLARATIVE, to assert what we think certain; the POTENTIAL or SUBJUNCTIVE, for the purposes of whatever we think contingent; the INTERROGATIVE, when we are doubtful, to procure us information; and the REQUISITIVE, to assist us in the gratification of our volitions. The requisitive too, according to him, appears under two distinct species; either as it is IMPERATIVE to inferiors, or PREGATIVE to superiors.

For establishing such a variety of modes as this, no sort of foundation whatever appears. The same reasoning which induced the author to give us an interrogative and requisitive mode, might have made him give us a hortative, a dissuasive, a volitive, and innumerable other modes, with which no language is acquainted. But besides perplexing his reader with useless distinctions, we cannot help thinking that Mr Harris has fallen into some mistakes with regard to the import of those modes which are universally acknowledged. According to him, assertion is the characteristic of the indicative, and that which distinguishes it from the subjunctive or potential; but this is certainly not true, for without an assertion, the verb cannot be used in any mode. Of this the learned author, indeed, seems to have been aware, when he observed of the subjunctive mode, that it is employed "when we do not strictly assert," and that "it implies but a dubious and conjectural assertion." The

truth is, that the assertion implied in this mode, though it is not concerning the same thing, is equally positive and absolute with that conveyed by the indicative. An example quoted by himself should have set him right as to this matter:

Sed tacitus pasci si posset corvus, HABERET Plus dapis, &c.

Who does not feel that the assertion contained in *haberet*, is as absolute and positive as any assertion whatever?

75. Perhaps we may be asked to define what we mean by a mode. We know not that we can define it to universal satisfaction. Thus much, however, seems to be obvious, that those variations which are called modes do not imply DIFFERENT MODIFICATIONS of the ACTION of the verb. *Amo, Amem, Ama*, do not signify modes of LOVING; for modes of loving are, loving MUCH, loving LITTLE, loving LONG, &c.—Shall we then get over the difficulty by saying, with Mr Harris, that "modes exhibit some way or other the soul and its affections?" This is certainly true; but it is nothing to the purpose; for it does not distinguish the meaning of mode from the object of language in general, all languages being intended to exhibit the soul and its affections.

Grammatical modes of verbs have been defined by Mode de-
Dr Gregory to be "concise modes of expressing some fincd.
of those combinations of thoughts which occur most frequently, and are most important and striking." This is a just observation; but perhaps he would have given a more complete definition had he said, that grammatical modes of verbs are concise modes of expressing some of those combinations of thoughts which occur most frequently, and of which ASSERTION is an essential part (T). This indeed seems to be the real account of the matter, especially if our notion of the nature of verb be well founded,

(s) The imperative, for instance, may be resolved into a verb of commanding in the first person of the present of the indicative, and a word denoting the action of the primary verb, commonly called the infinitive mode of that verb. Thus, *I nunc et versus tecum meditare canores*, and "*Jubeo te nunc ire et tecum meditari*," &c. are sentences of the very same import. The subjunctive may be resolved in the same manner by means of a verb denoting power or capacity; for *credam*, and *possum credere*, may be often used indifferently. The indicative mode, however, is not thus convertible with another verb of affirming in the first person of the present of the indicative, and a word denoting the action of the primary verb: for *Titius scribit*, "Titius writes," is not of the same import with *dico Titium scribere, quod Titius scribat*, "I say that Titius writes." The first of these sentences, as has been already shown, contains but one assertion; the second obviously contains two. *Titius writes*, is equivalent to *Titius is writing*; *I say that Titius writes*, is equivalent to *I AM saying that Titius is writing*. The reason why the imperative and subjunctive are resolvable into expressions into which the indicative cannot be resolved, will be seen when the import of each of those modes is ascertained.

(T) Every verb, except the simple verb *am, ait, is, &c.* expresses without modes a combination of thoughts, viz. affirmation and an attribute. The affirmation, however, alone is essential to the verb, for the attribute may be expressed by other words. It is indeed extremely probable, that, in the earliest ages of the world, the affirmation and attribute were always expressed by different words; and that afterwards, for the sake of conciseness, one word, compounded perhaps of these two, was made to express both the affirmation and the attribute: hence arose the various classes of verbs, active, passive, and neuter. Of a process of this kind there are evident signs in the Greek and some other tongues. But the improvers of language stopped not here. The same love of conciseness induced them to modify the compound verb itself, that it might express various combinations of thought still more complex: but in all these combinations assertion was of necessity included; for if the word had ceased to assert, it would have ceased to be a verb of any kind.

Soon after this short note was written, and the whole article finished for the press, we accidentally met with *Pickbourn's Dissertation on the English Verb*. Of that work it belongs not to us to give a character. Such of our readers as shall peruse it, will see that on many points we differ widely in opinion from the author; but we have no painful apprehension of any comparison which may be made. It gives us pleasure, however, to find,

Verbs. founded, that its *essence* consists in *affirmation*. And in this opinion we are the more confirmed, from a conviction that no man *ever* employs language on *any occasion* but for the purpose of *affirming something*. The speaker may affirm something directly of the *action itself*; something of the agent's *power* or *capacity* to perform it; or something of his own *desire* that it should be performed, &c.—but still he must *affirm*.

81
All modes equally indicative.

If this be so, then are all the modes equally *indicative*. Some may be indicative of *perceptions*, and others of *volitions*; but still they all contain *indications*. On this idea the three foregoing modes of *amo* will be thus distinguished. When a man indicates his *present feeling* of the passion of love, he uses the first; when he indicates his *present capacity* of feeling it, he uses the second; and when he indicates his *present desire* that the person to whom he is speaking would entertain that passion, he uses the *third*.

76. As to what Mr Harris calls the *interrogative* mode, he himself observes that it has a near affinity to the *indicative*. It has in fact not only a near affinity to it, but, as far as language is concerned, there is not between the one and the other the slightest difference. For, in *written* language, take away the *mark* of *interrogation*, and, in *spoken* language, the *peculiar tone of voice*, and the *interrogative* and *indicative* modes appear *precisely the same*. That such should be the case is extremely natural.

To illustrate this, let us for once speak in the singu-

lar number, and conceive one of our readers to be present. I *assert* a thing, taking the *truth* of it for *granted*; but if you know me to be *wrong*, I *presume* that you will set me *right*: in this case, assertion produces the same effect as *interrogation*. Instances perpetually occur in common conversation. An acquaintance says to me—"You took a ride this morning?" I answer *yes* or *no* according to the case; and the same effect is produced as if he had said—"Did you take a ride this morning?" In this way, at first, would simple *assertions* be employed to procure information wanted. *Fecisti*—you *did* such a thing; *fecisti ne*—you *did* it *not*;—either would produce the proper reply, and the information wanted would be gained (v). This being observed as language improved, men would accompany such a sentence with a *peculiar tone of voice*, or other marks, to signify more unequivocally that they wanted *information*, or that *such information* was the *only object* of their speech. Farther progress in refinement would lead them to alter the *position of the words* of a sentence when they meant to *ask a question*, as we do in *English*, saying (when we *assert*), "You have read Euripides;" (when we *interrogate*), "Have you read Euripides?"

In *Greek* and *Latin* questions are asked commonly enough by the particles *u* and *an*. These particles we know to be exactly equivalent to the English particle *if*, at least to the sense in which that particle is commonly taken. *An fecisti* is "If you did it;" and the sentence

that his notions respecting the origin of such verbs as express at once *assertion* and an *attribute*, are the same with those which had occurred to ourselves.

"The copula *is* appears (says Mr Pickbourn) to have been coeval with language itself. But we have not the same evidence to convince us, that that must necessarily have been the case of any other finite verb; for the copula *is*, containing only an *affirmation*, is much more simple than a verb which unites in one word both an *attribute* and an *affirmation*. Since therefore people, in their first attempts to express their ideas by words, would scarcely think of any thing more than what was absolutely necessary, it is probable they would be some time before they invented any other word containing in itself an *assertion* or *affirmation*; for they would not very early think of contriving words so *complex* in their nature as to include in them both the *name* of an *action* and an *assertion*.

"I conjecture, that the first mode of expressing *actions* or *passions* would be by *participles* or *verbal nouns*, i. e. words signifying the *names* of the *actions* or *passions* they wanted to describe; and these words connected with their subject by the copula *is*, might in those rude beginnings of language tolerably well supply the place of verbs: e. g. from observing the operations of nature, such words as *rain* or *raining*, *thunder* or *thundering*, would soon be invented; and by adding the copula *is*, they would say, *thundering* or *thunder is* or *is not*, *raining* or *rain is*; which, by the rapidity of pronunciation, might in time form the verbs *rains*, *thunders*, &c. The observation of their own *actions*, or the *actions* of the animals around them, would soon increase their stock of ideas, and put them upon contriving suitable expressions for them. Hence might arise such words as these; *sleep* or *sleeping*, *stand* or *standing*, *run* or *running*, *bite* or *biting*, *hurt* or *hurting*; and by joining these to substantives by means of the copula *is*, they might form such sentences as these—*Lion is sleeping*, or perhaps *lion sleep is*, *stand is*, &c. which would soon be contracted into *lion sleeps*, *stands*, *runs*, *bites*, *hurts*, &c. Thus, our little insulated family might become possessed of verbs including an *attribute* and an *affirmation* in one word."

This account of the origin of *active*, *passive*, and *neuter verbs*, is certainly ingenious; and, in our opinion, it is not more ingenious than just when applied to the Greek and other ancient languages, though it is not applicable to the English: but it seems to be quite irreconcilable with the definition of *verb*, which the author has adopted from Bishop Lowth; and indeed with every other definition except that which makes the essence of *verb* to consist in *simple affirmation*.

(v) Of a question put in the form of an *assertion* we have a remarkable instance in the Gospel of St Matthew. When Christ stood before Pilate, the governor asked him, saying, *Σὺ εἶ βασιλεὺς τῶν Ἰουδαίων*. That this sentence was pronounced with a view to obtain some answer, is evident from the context; yet it is as plainly an *affirmation*, though uttered probably in a scoffing tone, as the serious confession of Nathaniel, *Σὺ εἶ βασιλεὺς τῶν Ἰσραηλίων*. Had not the question been put in this form, which *asserts* Christ to be the king of the Jews, the reply could not have been *Σὺ λέγεις*; for without an *assertion* the governor would have said nothing. See Dr Campbell's *Translation of the Gospels*, where the form used in the original is with great propriety retained in the version.

Verbs — fence may either be an abbreviation for *dic an fecisti*, “tell me if you did it;” or *an* may perhaps be, as if certainly is, the imperative mode of some obsolete verb equivalent to *give*; and in that case, *an fecisti* will be a complete interrogative sentence, signifying, “you did it, give that.”—But of the *interrogative mode* of Mr Harris we have said enough; perhaps our readers will think, too much, since it is a useless distinction not found in any language. It will, however, be proper to say something of his *precativ mode*, as far as it is the same with the *optative mode* of the Greek grammarians. And,

82
Of the optative mode.

77. Nothing, we think, can be clearer, than that the Greek *optative* constitutes *no distinct mode* of the *verb*, whatever meaning be annexed to the word *mode*. The different tenses of the *optative* are evidently nothing but the *past tenses* of the corresponding tenses of the *subjunctive*. Præs. sub. *τυπῶ*, I may strike. Præs. opt. *τυπῶμι*, I might strike, &c. This is proved to be indubitably the case by the uniform practice of the Greek writers. Examples might be found without number were one to read in search of them. The following sentence will illustrate our meaning: *Ἐχθροῖσι Ἀθηναῖοι ἰνα βοηθῶσι τοῖς Ἀργείοις*, “the Athenians come that they may assist the Argives.” Here the leading verb *ἰνα βοηθῶσι* being of the *present* tense, the dependent verb *βοηθῶσι* is the *present subjunctive*. But change the former to the *past time*, and the latter must also be changed. *Ἡκεῖσε Ἀθηναῖοι ἰνα βοηθῶσιν τοῖς Ἀργείοις*, “the Athenians came that they might assist the Argives.” Here it is plain that *βοηθῶσιν*, the present of the *optative*, is the *past time* of *βοηθῶσι*, the present of the *subjunctive*; and the same in other instances.

It is almost unnecessary to add, that when *this mode* is employed to denote a *wish*, the wish is not *expressed* by the *verb*, but is *understood*. Such abbreviated expressions to denote a wish are common in all languages. Thus, in Greek,

Ἵμιν μὲν θεοὶ δοῦν, ἰδομεκὶν δὲματ' ἕροσσι

Ἐκπρῶσι Πρῆταμοῖο πόλι, &c.

signifies, “The gods might give you (or, as we say in English, *changing* the position of the verb, *might the gods give you*) to destroy,” &c. So in Latin, *Ut te omnes dii deaque perdant*, “That all the gods and goddesses may curse you!” Again, in English, “O that my head were waters!” &c. In all these, and such like sentences, the words equivalent to *I wish, I pray*, are understood. In Greek a *wish* is sometimes introduced by the particle *ἰ* or *ἰνα*, *if*; as in Homer.

Ἐἰδ' ἰφίλιε τ' ἀγῶνος τ' ἕμισται, ἀγῶμος τ' ἀπολισθαί.

“If it had been your fate not to be born, or to die unmarried!” The supplement is, “It would have been happy for your country,” or some such thing. In like manner, a poor person not uncommonly intreats a favour by saying, “Sir, *if* you would be so good!” Here he *stops*; but the completion of his sentence is, “It would make me happy.” In all these cases a *wish*

is not *formally expressed* by the speaker, but *inferred* by the hearer. They are therefore instances of that tendency which mankind universally discover to abbreviate their language, especially in cases where the passions or feelings are interested.

83
Only three modes necessary, the indicative, subjunctive, and imperative.

78. The *interrogative* and *optative modes* being set aside as superfluous, it would appear from our investigation, that the *real distinct modes* of the *verb*, which are found in the most copious and varied language, are only three; the *indicative*, the *subjunctive*, and the *imperative*: and that these are all that can be considered as *necessary*; the *first* to indicate the speaker's *feeling* or *acting*, the *second* to indicate his *capacity* of feeling or acting, and the *third* to indicate his *desire* that the person to whom he speaks *should feel* or *act*.

Here again we have the misfortune to find ourselves differ in opinion with Dr Gregory; who seems to think, that a greater number of modes, if not absolutely necessary, would, however, be highly useful. His words are: “All languages, I believe, are defective in respect of that variety and accuracy of combination and of distinction, which we know with infallible certainty take place in thought. Nor do I know of any particular in which language is more deficient than in the expressing of those *energies* or modifications of thought; some of which always are, and all of which might be, expressed by the grammatical moods of verbs. Of this there cannot be a clearer proof than the well-known fact, that we are obliged to express by the same mood very different modifications or *energies* of thought. As, for instance, in the case of the grammatical mood called the *imperative*, by which we express occasionally prayer to GOD, command to a slave, request to a superior, advice to an equal or to any one, order as from an officer to his subaltern, supplication to one whom we cannot resist.”—If these be, as the author calls them, *specific* differences of thought, he will not surely object to their being all ranked under one *genus*, which may be called *desire* (x). That the internal feelings, which prompt us to pray to God, to command a slave, to request a superior, to advise an equal, to give an order to an inferior, and to supplicate one whom we cannot resist, are all different in *degree*, cannot be denied. Each of them, however, is *desire*; and the *predication*, by which the desire is made known to the person whom we address, is the same in all, when we utter a prayer as when we utter a command, when we request as when we supplicate. But *predication alone* is that which constitutes the *verb*: for *desire* by itself, however modified, can be expressed only by an *abstract noun*; and the *mere energy* of desire, when not applied to a particular *energiser*, can be expressed only by a *participle*, or by what is commonly, though improperly, called the *infinitive mode*. Now it is certainly conceivable, that a few *shades of meaning*, or a few (y) *degrees* of one *general energy*, might be marked by

(x) “DESIRE;—wish; with eagerness to obtain or enjoy.” Johnson.

“The uneasiness a man finds in himself upon the absence of any thing, whose present enjoyment carries the idea of delight with it, is that we call DESIRE. Good and evil, present and absent, work upon the mind; but that which immediately determines the will, from time to time, to every voluntary action, is the uneasiness of DESIRE, fixed upon some absent good.” Locke.

This, whether it be sound philosophy or not, is surely sufficient authority for using the word *desire* to denote the *genus*; of which *prayer, command, advice, supplication, &c.* may be considered as so many distinct *species*.

(y) Dr Gregory seems to think, that not barely a few, but a vast number, of these *energies* might be so marked.

Verbs. by corresponding variations of such verbs as combine energy with predication; and there could be no great impropriety in calling those variations *modes*, or rather *modes of modes*: but that such a multiplication of modes would be an-improvement in language, is by no means evident. The verb, with the modes and tenses which it has in all languages, is already a very complex part of speech; which few are able, and still fewer inclined, to analyze: and it would surely be of no advantage to make it more complex by the introduction of *new modes*, especially when those *degrees of energy* which could be marked by them are with equal and perhaps greater precision marked, in the *living speech*, by the different tones of voice adapted to them by nature; and, in *written language*, by the reader's general knowledge of the subject and of the persons who may be occasionally introduced. If there be any particular delicacy of sentiment, or energy, which cannot thus be made known, it is better to express it by a name appropriated to itself, together with the *simple* and original verb of affirmation, than to clog the *compound* verb with such a multiplicity of variations as would render the acquisition of every language as difficult as is said to be that of the Chinese written characters. The *indicative*, *subjunctive*, and *imperative*, are there-

fore all the modes of the verb which to us appear to be in any degree *necessary* or expedient; and they are in fact all the modes that are really found in any language with which we are acquainted.

For the INFINITIVE, as has been already observed, The infinitive no seems on every account to be improperly styled a *mode*. mode of the verb, but an abstract noun. To that name it has no title which we can perceive, except that its *termination sometimes* (for even this is not true universally) differs in the learned languages from the terminations of the *other parts* of the verb. Nay, if *affirmation* be, as it has been proved to be, the very *essence* of verb, it will follow, that the *infinitive* is no part of the verb at all; for it expresses *no affirmation*. It forms no complete sentence by itself, nor even when *joined to a noun*, unless it be aided by some *real part* of a verb either expressed or understood. *Scribo, scribebam, scripsi, scripseram, scribam, scripsero*; "I am writing, I was writing, I have written, I had written, I shall write, I shall have written," do each of them contain an *affirmation*, and constitute a complete sentence: but *scribere* "to write," *scripsisse* "to have written," affirm nothing, and are not more applicable to any one person than to another. In a word, the *infinitive* is nothing more than an *abstract noun* (z), denoting the *simple ENERGY* of the verb, in conjunction with

"*Affirming* (says he), *denying*, *testifying*, foretelling, asking, answering, *wishing*, *hoping*, *expecting*, believing, knowing, doubting, supposing, stipulating, being able, commanding, *praying*, requesting, *supplicating*, loving, hating, fearing, despairing, being accustomed, wondering, admiring, wavering, swearing, *advising*, *refusing*, *exhorting*, *dissuading*, *encouraging*, promising, threatening, &c. all admit very readily of being combined with the general import of a verb." He adds, that "if every one of them had been expressed in all languages by variations as striking as those of *τυνην*, *τυνησιμω*, and *τυνησιν*, they *must* have been acknowledged as distinct *moods* of the verb."

If all these words denote different energies of thought, which, however, may be doubted, and if all those different energies, with many others for which, as the author justly observes, it is not easy to find names, could, like *capacity* and *desire*, be combined with the *general action* or *energy* of one verb; and if those combinations could be marked by *corresponding variations* of that verb; we should indeed acknowledge such *variations* to be distinct *modes*, or *modes of modes*, of the verb. But we doubt much if all this be possible. We are certain that it would be no improvement: for it seems to be evident, either that, in some of the modes, the radical letters of the original verb must be changed, and then it would cease to be the same verb; or that many of the modes must be expressed by words of very unmanageable length; not to mention that the additional complication introduced by so many minute distinctions into a part of speech already exceedingly complex, would render the import of the verb absolutely unintelligible to nine-tenths even of those who are justly styled *the learned*.

(z) In our idea of the *infinitive*, we have the honour to agree with the learned and excellent *Ruddiman*; whose words are, "Non ineptè hic modus a veteribus quibusdam VERBI NOMEN est appellatum. Est enim (si non verè ac semper, quod nonnulli volunt, nomen substantivum) significatione certè ei maxime affinis; ejusque vices sustinet per omnes casus. Et quidem manifestè substantivum videtur, cum *adjectivum* ei additur neutri generis: ut, *Cic. Att. xiii. 28. Cum vivere ipsum turpe sit nobis.*—*Pers. v. 53. Velle suum cuique est.*—*Cic. Fin. i. 1. Totum hoc displicet philosophari.*—*Petron c. 52. Meum intelligere nulla pecunia vendo.* Item, *absque adjectivo*: ut, *Ovid Met. ii. 483. Posse loqui eripitur, i. e. potestas loquendi.*—*Plaut. Bacch. i. 2. 50. Hic vereri perdidit, i. e. verecundiam.*—*Cic. Tusc. v. 38. Loquor de docto homine et erudito, cui vivere est cogitare, i. e. cujus vita est cogitatio* [*GRAMMATICÆ LATINÆ INSTITUTIONES: Pars secunda, lib. i. cap. 2. where the reader will find examples of the infinitive used by the best Roman writers as a substantive noun in every case.*]

This opinion of *Ruddiman* and his ancient grammarians has been lately controverted with much ingenuity by *Dr Gregory*; who seems to think, that in the *infinitive* alone we should look for the *essence* of the verb divested of every accidental circumstance, time only excepted. If this be indeed the case, almost every thing which we have said of the verb, its *tenses*, and its *modes*, is erroneous; and he who takes his principles of grammar from the *Encyclopædia*, will fill his head with a farrago of absurdities. The writer of the article, however, has been at much pains to acquire correct notions of the subject: he has studied the writings of others; he

Verbs.

with *time*; and is not a *mode*, as far as we can conceive, of any thing. Thus, *Scire tuum nihil est*, is the same with *Scientia tua nihil est*; and, "Death is certain," with "To die is certain."

35
Of expressing commands by the future tense.

79. Before we dismiss the subject of *modes*, it may not be improper to take notice of the connection which Mr Harris, after Apollonius, has found between *commanding* and *futurity*. "Intreating and commanding (he says) have a necessary respect to the *future only*. For what have they to do with the *present* and the *past*, the natures of which are immutable and necessary." This is surely confounding *commands* with the *execution* of commands. But the learned writer proceeds to inform us, that "it is from the *connection* of *futurity* with *commands*, that the *future* of the *indicative* is sometimes used for the *imperative mode*." The *connection*, of which he speaks, appears to us entirely imaginary; for *futurity* has nothing to do with *commands*, though it may

with the *execution* of them. The *present time* is the time of *commanding*, the *future* of *obeying*. But supposing the connection *real*, it would not account for the *future tenses* being used *imperatively*. For although it were true, as it is evidently false, that commands are *future*, it would not follow that the relation is *convertible*, or that employing the *future* should imply a *command*. The principle upon which such expressions as, THOU SHALT NOT KILL, come to have the force of a *command*, seems to be this. When a person, especially one possessed of authority, asserts that an *action*, depending on the *will* of a *free agent*, and therefore in its own nature *contingent*, *shall* or *shall not* actually take place; what are we to *conclude* from such an assertion? Why surely it is natural to conclude, that it is his *will*, his *command*, that his assertion be *verified*. The English word *shall*, if we be well informed, denoted originally *obligation*; a sense in which its past tense *should* is still

Verbs.

has consulted several persons of undoubted learning, who have devoted a great part of their time to grammatical investigations; and he is extremely unwilling to suppose that all his inquiries respecting the most important part of speech have ended in error. He trusts, therefore, that he shall not be deemed a petulant caviller, though he examine with some severity the principal observations and arguments upon which the Doctor has built his theory. Upon that examination he enters with diffidence: for the learned Professor's knowledge of the various powers of the mind appears, even in this essay, to be such as eminently qualifies him for ascertaining the precise import of *every* species of words employed for the purpose of communicating thought; and with such a man the present writer would be much happier to agree than to differ in opinion.

The Doctor acknowledges (Trans. of the Royal Society, Edinburgh, vol. ii. lit. class, p. 195.), that the *infinitive* is most improperly called a *mode*: and on that account he thinks we ought to turn our thoughts *exclusively* to it, "when we endeavour to investigate the general import of the verb, with a view to ascertain the *accident* which it denotes; and be led, step by step, to form a distinct notion of what is *common* in the *accidents* of all verbs, and what is *peculiar* in the *accidents* of the several classes of them, and thereby be enabled to give good definitions, specifying the *essence* of the verb," &c. It may be true, that to the *infinitive exclusively* we should turn our attention, when we wish to ascertain the *accident* denoted by a *particular verb* or class of verbs; i. e. the *kind of action, passion, or state of being*, of which, superadded to affirmation, that verb or class of verbs is expressive: but in *accidents* of this kind it may be doubted if there be any thing that with propriety can be said to be *common* to all verbs. There seems indeed to be nothing *common* to all verbs but that which is *essential* to them, and by which they are distinguished from *every other part* of speech; but every kind of *action, passion, and state of being*, may be completely expressed by *participles* and *abstract nouns*; and therefore in such *accidents* we cannot find the *essence* of the verb, because such accidents distinguish it not from other parts of speech. Were a man called upon to specify the *essence* of *verse* or *metre*, he would not say, that it consists in the meaning of the words, or in the using of these words according to the rules of syntax. In every kind of *verse* where words are used they have indeed a meaning, and in all good verses they are grammatically constructed; but this is likewise the case in *prose*, and therefore it cannot be the *essence* of *verse*. The *essence* of *verse* must consist in something which is not to be found in *prose*, viz. a certain harmonic succession of sounds and number of syllables: and the *essence* of the *verb* must likewise consist in something which is not to be found in *any other part of speech*; and that, we are persuaded, is nothing but *affirmation*. But if *affirmation* be the very *essence* of the verb, it would surely be improper, when we endeavour to ascertain the general import of that part of speech, to turn our thoughts exclusively to a word which implies *no* affirmation; for what does not affirm, cannot in strictness of truth be either a *verb* or the *mode* of a verb.

In the same page it is said, that "the *infinitive* denotes that kind of thought or combination of thoughts which is common to all the other modes." In what sense this is true, we are unable to conceive: it denotes indeed the same *accident*, but certainly not the same *thought* or *combination* of thoughts. In the examples quoted, *Non est VIVERE, sed VALERE vita*, &c. the infinitives have evidently the effect of *abstract nouns*, and not of *verbs*; for though *vivere* and *valere* express the same *states of being* with *vivo* and *valeo*, they by no means express the same *combination of thoughts*. *VIVO* and *VALEO* affirm that *I AM living*, and that *I AM well*; and he who utters these words must think *not of life and health in the abstract*, but of *life and health as belonging to himself*. *VIVERE* and *VALERE*, on the other hand, affirm *nothing*; and he who utters them thinks only of the *states of living* and of *being in health*, without applying them to any particular person.

The exquisitely learned author of *The Origin and Progress of Language*, having said that the *infinitive* is used either as a *noun*, or that it serves to connect the verb with another verb or a noun, and so is useful in syntax, the Doctor combats this opinion and infers the infinitive to be truly a *verb*; because "the thought expressed by

Verbs. still commonly employed. In English, therefore, the foregoing process of *inferring a command from an assertion of futurity* seems to have been reversed; and the word *shall*, from denoting a *command or obligation*, has come to denote *futurity* simply.

26
 f verbs, as
 they are
 active, pas-
 sive, or
 neuter.

80. Having considered the *verb* in its *essence*, its *tenses*, and its *modes*, we might seem to have exhausted the subject; but there is still something more to be done. Grammarians have distinguished *verbs* into several *species*: and it remains with us to inquire upon what principle in nature this distinction is made, and how far it proceeds. Now it must be obvious, that if *predication* be the *essence of verbs*, all *verbs*, as such, must be of the *same species*; for *predication* is the *same* in every *proposition*, under every *possible circumstance*, and by *whomsoever it is made*. But the greater part of verbs contain the *predicate* as well as the *predication* of a pro-

position; or, to speak in common language, they denote an *attribute* as well as an *affirmation*. Thus, *lego* is "I am reading;" *ambulo*, "I am walking;" *sto*, "I am standing;" *verbero*, "I am striking;" *verberor*, "I am stricken." But the *attributes* expressed by these *verbs* are evidently of different kinds; some consisting in *action*, some in *suffering*, and some in a state of being which is *neither active nor passive*. Hence the distinction of verbs, according to the *attributes* which they denote, into *active*, *passive*, and *neuter*. *Lego*, which is an assertion that I am employed in the *act of reading*, is an *active verb*; *verberor*, which is an assertion that I am *suffering* under the rod, is a *passive verb*, because it denotes a *passion*; and *sto*, which is an assertion that I am *standing still*, is said to be a *neuter verb*, because it denotes neither *action* nor *passion*. But it is self-evident that there cannot be *action* without an *agent*, nor *passion* without

Verbs.

by means of *it*, may be expressed in synonymous and convertible phrases, in different languages, by means of other parts or moods of the verb." Of these synonymous and convertible phrases he gives several examples, of which the first is taken from Hamlet's soliloquy. "To be or not to be, that is the question," he thinks equivalent in meaning to, "The question is, whether we shall be or shall not be?" But we are persuaded he is mistaken. "Whether we shall be or shall not be," is a question asking, whether we shall exist at some *future and indefinite time*? but the subject of Hamlet's debate with himself was *not*, Whether, if his conscious existence should be interrupted, it would be afterwards at some *future and indefinite time restored*? but whether it was to *continue uninterrupted* by his exit from this world? This, we think, must be self-evident to every reader of the Soliloquy. It is likewise very obvious, that the word *question* in this sentence does not signify *interrogatory*, but *subject of debate* or *affair to be examined*; and that the word *that* serves for no other purpose than to complete the verse, and give additional *emphasis*, perhaps, to an inquiry so important. "To be or not to be, that is the question," is therefore equivalent in all respects to "The continuance or non-continuance of my existence, is the matter to be examined;" and the infinitive is here indisputably used as an abstract noun in the nominative case. Should it be said, that the Doctor may have taken the sentence by *itself*, unconnected with the *subject of Hamlet's soliloquy*; we beg leave to reply that the supposition is impossible; for, independent of the circumstances with which they are connected, the words "To be or not to be," have no perfect meaning. Were it not for the subject of the soliloquy, from which every reader supplies what is wanting to complete the sense, it might be asked, "To be or not to be"—*What?* A coward, a murderer, a king, or a dead man! Questions all equally reasonable, and which in that case could not be answered.

With the same view, to prove the infinitive to be truly a *verb*, the Doctor proceeds to remark upon the following phrases, *Dico, credo, puto, Titium existere, valere, jacere, cecidisse, procubuisse, projecisse Mævium, projectum fuisse a Mævio*; which, he says, have the very same meaning with *dico, &c. quod Titius existat, quod jaceat, quod ceciderit, &c.* He adds, that "the *infinitives*, as thus used, acquire not any further meaning, in addition to the radical import of the verb with tense, like the proper moods; but the *subjunctives* after *quod* lose their peculiar meaning as *moods*, and signify no more than bare *infinitives*." In the sense in which this observation is made by the author, the very reverse of it seems to be the truth. The *infinitives*, as thus used, acquire, at least in the mind of the reader, something like the power of *affirmation*, which they certainly have not when standing by themselves; whereas, the *subjunctives* neither *lose* nor *acquire* any meaning by being placed after *quod*. *Dico, credo, puto, Titium existere, valere, jacere, &c.* when translated literally, signify, *I say, believe, think, Titius to exist, to be well, to lie along*; a mode of speaking which, though now not elegant, was common with the best writers in the days of *Shakespeare*, and is frequently to be found in the writings of *Warburton* at the present day. *Dico, credo, puto, quod Titius existat, quod jaceat, &c.* signifies literally, *I say, believe, think, that Titius may exist, may lie along, &c.* Remove the verbs in the indicative mode from the former set of phrases, and it will be found that the *infinitives* had acquired a meaning, when conjoined with them, which they have not when left by themselves: for *Titium existere, jacere*; "Titius to exist, to lie along," have no complete meaning, because they *affirm nothing*. On the other hand, when the indicative verbs are removed, together with the wonder-working *quod*, from the latter set of phrases, the meaning of the *subjunctives* remains in all respects as it was before the removal; for *Titius existat, jaceat, &c.* signify, *Titius may exist, may lie along*, as well when they stand by themselves as when they make the final clauses of a compound sentence. Every one knows that *quod*, though often called a conjunction, is always in fact the *relative pronoun*. *Dico, credo, puto, quod Titius existat*, must therefore be construed thus: *Titius existat (est id) quod dico, credo, &c.* "Titius may exist is that thing, that proposition, which I say, believe, think." In the former set of phrases, the *infinitives* are used as abstract nouns in the accusative case, denoting, in conjunction with *Titium*, one complex conception, the *existence, &c. of Titius*: *Dico, credo, puto*; I say, believe, think; and the *object* of my speech, belief, thought, is *Titium existere*, "the existence of Titius."

Verbs. without a *passive being*; neither can we make a *predication of any kind*, though it denote neither *action* nor *passion*, without predicating of *something*. All verbs, therefore, whether *active*, *passive*, or *neuter*, have a necessary reference to some *noun* expressive of the *substance*, of which the *attribute*, denoted by the verb, is *predicated*. This noun, which in all languages must be in the *nominative case*, is said to be the *nominative* to the *verb*; and in those languages in which the *verb* has *person* and *number*, it must in *these respects* agree with its *nominative*.

87
All verbs have a necessary reference to a noun in the nominative case.

88
Active verbs transitive or intransitive.

Of *action*, and consequently of *verbs denoting action*, there are obviously two kinds. There is an *action* which passes from the *agent* to some *subject*, upon which he is employed; and there is an *action* which respects *no object* beyond the *agent himself*. Thus *lego* and *ambulo* are verbs which equally denote *action*; but the action of *lego* refers to some *external object* as well as to the *agent*; for when a man is *reading*, he must be reading *something*, a book, a newspaper, or a letter, &c. whereas, the action of *ambulo* is confined wholly to the *agent*; for when a man is *walking*, he is employed upon *nothing beyond himself*,—his *action* produces no *effect* upon any thing external. These two species of verbs have been denominated *transitive* and *intransitive*; a designation extremely proper, as the distinction which gave rise to it

is philosophically just. *Verbs* of both species are *active*; *Participles*, but the action of those only which are called *transitive* respects an external object; and therefore in those languages of which the nouns have cases, it is only after *verbs* which are *transitive* as well as *active*, that the *noun* denoting the *subject* of the action is put in the *accusative* or *objective case*. *Verbs* which are *intransitive*, though they be really *active*, are in the structure of the sentences considered as *neuter*, and govern *no case*.

89
The former only govern nouns in the accusative case.

And so much for that most important of all words the *VERB*. We proceed now to the consideration of *participles*, *adjectives*, and *adverbs*; which as they have a near relation to one another, we shall treat of in the same chapter.

CHAP. V. Of Participles, Adjectives, and Adverbs.

SECT. I. Of Participles.

89
90
91
92
93
94
95
96
97
98
99
100
101
102
103
104
105
106
107
108
109
110
111
112
113
114
115
116
117
118
119
120
121
122
123
124
125
126
127
128
129
130
131
132
133
134
135
136
137
138
139
140
141
142
143
144
145
146
147
148
149
150
151
152
153
154
155
156
157
158
159
160
161
162
163
164
165
166
167
168
169
170
171
172
173
174
175
176
177
178
179
180
181
182
183
184
185
186
187
188
189
190
191
192
193
194
195
196
197
198
199
200
201
202
203
204
205
206
207
208
209
210
211
212
213
214
215
216
217
218
219
220
221
222
223
224
225
226
227
228
229
230
231
232
233
234
235
236
237
238
239
240
241
242
243
244
245
246
247
248
249
250
251
252
253
254
255
256
257
258
259
260
261
262
263
264
265
266
267
268
269
270
271
272
273
274
275
276
277
278
279
280
281
282
283
284
285
286
287
288
289
290
291
292
293
294
295
296
297
298
299
300
301
302
303
304
305
306
307
308
309
310
311
312
313
314
315
316
317
318
319
320
321
322
323
324
325
326
327
328
329
330
331
332
333
334
335
336
337
338
339
340
341
342
343
344
345
346
347
348
349
350
351
352
353
354
355
356
357
358
359
360
361
362
363
364
365
366
367
368
369
370
371
372
373
374
375
376
377
378
379
380
381
382
383
384
385
386
387
388
389
390
391
392
393
394
395
396
397
398
399
400
401
402
403
404
405
406
407
408
409
410
411
412
413
414
415
416
417
418
419
420
421
422
423
424
425
426
427
428
429
430
431
432
433
434
435
436
437
438
439
440
441
442
443
444
445
446
447
448
449
450
451
452
453
454
455
456
457
458
459
460
461
462
463
464
465
466
467
468
469
470
471
472
473
474
475
476
477
478
479
480
481
482
483
484
485
486
487
488
489
490
491
492
493
494
495
496
497
498
499
500
501
502
503
504
505
506
507
508
509
510
511
512
513
514
515
516
517
518
519
520
521
522
523
524
525
526
527
528
529
530
531
532
533
534
535
536
537
538
539
540
541
542
543
544
545
546
547
548
549
550
551
552
553
554
555
556
557
558
559
560
561
562
563
564
565
566
567
568
569
570
571
572
573
574
575
576
577
578
579
580
581
582
583
584
585
586
587
588
589
590
591
592
593
594
595
596
597
598
599
600
601
602
603
604
605
606
607
608
609
610
611
612
613
614
615
616
617
618
619
620
621
622
623
624
625
626
627
628
629
630
631
632
633
634
635
636
637
638
639
640
641
642
643
644
645
646
647
648
649
650
651
652
653
654
655
656
657
658
659
660
661
662
663
664
665
666
667
668
669
670
671
672
673
674
675
676
677
678
679
680
681
682
683
684
685
686
687
688
689
690
691
692
693
694
695
696
697
698
699
700
701
702
703
704
705
706
707
708
709
710
711
712
713
714
715
716
717
718
719
720
721
722
723
724
725
726
727
728
729
730
731
732
733
734
735
736
737
738
739
740
741
742
743
744
745
746
747
748
749
750
751
752
753
754
755
756
757
758
759
760
761
762
763
764
765
766
767
768
769
770
771
772
773
774
775
776
777
778
779
780
781
782
783
784
785
786
787
788
789
790
791
792
793
794
795
796
797
798
799
800
801
802
803
804
805
806
807
808
809
810
811
812
813
814
815
816
817
818
819
820
821
822
823
824
825
826
827
828
829
830
831
832
833
834
835
836
837
838
839
840
841
842
843
844
845
846
847
848
849
850
851
852
853
854
855
856
857
858
859
860
861
862
863
864
865
866
867
868
869
870
871
872
873
874
875
876
877
878
879
880
881
882
883
884
885
886
887
888
889
890
891
892
893
894
895
896
897
898
899
900
901
902
903
904
905
906
907
908
909
910
911
912
913
914
915
916
917
918
919
920
921
922
923
924
925
926
927
928
929
930
931
932
933
934
935
936
937
938
939
940
941
942
943
944
945
946
947
948
949
950
951
952
953
954
955
956
957
958
959
960
961
962
963
964
965
966
967
968
969
970
971
972
973
974
975
976
977
978
979
980
981
982
983
984
985
986
987
988
989
990
991
992
993
994
995
996
997
998
999
1000

81. THE nature of *VERBS* being understood, that of *Participles* is not of difficult comprehension. Every *verb*, except that which is called the *substantive verb*, is expressive of an *attribute*, of *time*, and of an *assertion*. Now if we take away the *assertion*, and thus destroy the *verb*, there will remain the *attribute* and the *time*; and these combined make the essence of that species of words called

In confirmation of the same idea, that the *infinitive* is truly a *verb*, the author quotes from *Horace* a passage, which, had we thought quotations necessary, we should have urged in support of our own opinion:

Nec quicquam tibi prodest
Aërias TENTASSE domos, animoque rotundum
PERCURRISSE polum, morituro.

To our apprehension, nothing can be clearer than that *TENTASSE* and *PERCURRISSE* are here used as *nouns*; for if they be not, where shall we find a *nominative* to the verb *prodest*? It was certainly what was signified by *TENTASSE aërias domos, animoque rotundum PERCURRISSE polum*, that is said to have been no advantage to *Archytas* at his death. This indeed, if there could be any doubt about it, would be made evident by the two prose versions, which the professor subjoins to these beautiful lines. The first of which is as follows: *Nec quicquam tibi prodest quod aërias domos TENTAVERIS, et animo PERCURRERIS polum*; which must be thus constructed: *TENTAVERIS aërias domos, et PERCURRERIS animo polum (est id) quod nec quicquam tibi prodest*. This version, however, is not perfectly accurate: for it contains *two propositions*, while *Horace's* lines contain but *one*. The second, which, though it may be a crabbed inelegant sentence, expresses the poet's sense with more precision, is in these words: *Nec quicquam tibi prodest morituro tua TENTATIO domuum aëriarum, et CURSUSTUUS circa polum*. Having observed, with truth, that this sentence has the very same meaning with the lines of *Horace*, *Dr Gregory* asks, "Why are not *tentatio* and *cursus* reckoned verbs as well as *tentasse* and *percurrisse*?" Let those answer this question who believe that any of these words are truly verbs; for they are surely, as he adds, all very near akin; indeed so near, that the mind, when contemplating the import of each, cannot perceive the difference. Meanwhile, we beg leave in our turn to ask, Why are not *tentasse* and *percurrisse* reckoned *abstract nouns* as well as *tentatio* and *cursus*? To this question it is not easy to conceive what answer can be returned upon the *Doctor's* principles. In his theory there is nothing satisfactory; and what has not been done by himself, we expect not from his followers. On the other hand, our principles furnish a very obvious reason for excluding *tentatio* and *cursus* from the class of *verbs*; it is, because these words express *no predication*. *Tentasse* and *percurrisse* indeed denote *predication* no more than *tentatio* and *cursus*; and therefore upon the same principle we exclude them likewise from a class to which, if words are to be arranged according to their import, they certainly do not belong.

Should the reader be inclined to think that we have dwelt too long on this point, we beg him to reflect, that if our ideas of the essence of the verb and of the nature of the infinitive be erroneous, every thing which we have said of modes and tenses is erroneous likewise. We were therefore willing to try the solidity of those principles which hold the essence of the verb to consist in *energy*: and we selected *Dr Gregory's* theory for the subject of examination, not from any disrespect to the author, whom the writer of this article never saw; but because we believe his abilities to be such, that

Si Pergama destrud
Defendi possent, etiam hac defensa fuissent.

jectives ed PARTICIPLES. Thus, take away the *assertion* from the verb *γράφω* *writeth*, and there remains the *participle* *γράφων* *writing*; which, without the *assertion*, denotes the *same attribute* and the *same time*. After the same manner, by *withdrawing the assertion*, we discover *γέγραπτες* *written* in *εγγράφη* *wrote*; *γέγραπτον* *about to write* in *γράφω* *shall be writing*. This is Mr *Harris's* doctrine respecting *participles*; which, in our opinion, is equally elegant, perspicuous, and just. It has, however, been controverted by an author, whose rank in the republic of letters is such, that we should be wanting in respect to him, and in duty to our readers, were we to pass his objections wholly unnoticed.

82. It is acknowledged by *Dr Beattie*, that this, which we have taken, is the most convenient light in which the *participle* can be considered in universal grammar: and yet he affirms that *present participles* do not always express *present time*, nor *preterite participles* *past time*; nay, that *participles* have often no connection with *time at all*. He thus exemplifies his assertion, in *Greek*, in *Latin*, and in *English*.

"When *Cebes* says, *Ἐπιπυλασθενα πικισατρονυλις ο τω τωο Ιεπου ιου* 'We WERE WALKING in the temple of Saturn,' the *participle* of the present WALKING, is, by means of the verb WERE, applied to *time past*; and therefore of itself cannot be understood to signify any sort of time." Again, after observing, that in *English* we have but two simple *participles*, such as *writing* and *written*, of which the *former* is generally considered as the *present* and the *latter* as the *past*, the Doctor adds, But "the *participle* *writing*, joined to a verb of different tenses, may denote either *past* or *future* action; for we may say not only, *I AM writing*, but also, *I WAS writing* yesterday, and *I SHALL BE writing* to-morrow;" whence he infers that *no time whatever* is denoted by the *present participle*. But surely this is a hasty inference, drawn from the doctrine of *absolute time* and a *definite present*, which we have already shown to be groundless and contradictory. When we speak simply of an action as *present*, we *must* mean that it is *present* with respect to *something besides itself*, or we speak a jargon which is unintelligible, but we do not ascertain the *time* of its *presence*. From the very *nature of time*, an action may be *present now*, it may have *been present formerly*, or it may be *present at some future period*; but the *precise time* of its presence cannot be ascertained even by the *present of the indicative of the verb* itself; yet who ever supposed that the *present of the indicative* denotes *no time*? The *participle of the present* represents the *action of the verb as going on*; but an action cannot be going on without being *present in time* with something. When, therefore, *Cebes* says, "We were walking in the temple of Saturn," he represents the action of the verb *walk* as *present* with something; but by using the *verb* expressive of his *assertion* in a *past tense*, he gives us to understand that the *action* was *not present* with any thing at the period of his *speaking*, but at some *portion of time prior* to that period: what that *portion of time* was, must be collected from the subsequent parts of his discourse. The same is to be said of the phrases *I was writing yesterday*, and *I shall be writing to-morrow*. They indicate, that the *action of the verb WRITE* was *present with me yesterday*, and *will again be present with me to-morrow*. The *action*, and the *time of action*, are denoted by the *participle*; that action is *affirmed to*

belong to *me* by means of the verb; and the *time* at *Adjectives*, which it belonged to *me* is pointed out by the *tenses* of that verb, *am*, *was*, and *shall be*. All this is so plain, that it could not have escaped *Dr Beattie's* penetration, had he not hastily adopted the absurd and contradictory notion of a *definite present*.

Of the truth of his assertion respecting *past participles*, he gives a *Greek* and a *Latin* example. The *former* is taken from *St Mark*: *ἰ πιστωτας ευθεσιας*; and the *latter* is that which is commonly called the *perfect future* of the passive verb *amor*, *amatus fuero*. In the first instance, he says that the *participle*, though belonging to the aorist of the *past time*, must be rendered either by the *indefinite present*, "he who *believeth*;" or by the *future*, "he who *will believe*;" and the reason which he gives for this rendering of the word is, that "the believing here spoken of is considered as *posterior* in time to the *enunciation* of the *promise*." This is indeed true, but it is not to the purpose; for with the *enunciation* of the *promise*, the *time of the participle* has no manner of concern. The time of *πιστωτας* depends entirely upon the time of *ευθεσιας*, with respect to which it must *undeniably be past*. Our Lord is not here asserting, that he who *shall believe* at the *day of final retribution*, shall be *saved*; but that he who shall on that day be found to *have believed* in time *past*, shall be *saved*: and if the *participle* had not been expressive of a *finished action* and a *past time*, the whole sentence would have conveyed a meaning not friendly to the interests of the gospel. In like manner, the time of *amatus* is referred, *not* to the time of *speaking*, but to the time of *fuero*, with respect to which, who sees not that it is *past*? The two words, taken together, contain a declaration, that he who utters them *shall*, at some time *posterior* to that of speaking, *have BEEN loved*; *shall have been loved* denotes *two times*, both *future* with respect to the time of *speaking*; but when the time, denoted by *shall have*, comes to be present, that of the *participle loved* must be *past*, for it is declared that the *action* of it shall *then be complete* and *finished*.

We conclude, then, that it is *essential* to a *participle* to express both an *attribute* and *time*; and that such words as denote *no time*, though they may be in the *form* of *participles*, as *doctus*, "learned," *eloquens*, "eloquent," &c. belong to *another part of speech*, which we now proceed to consider.

SECT. II. *Of Adjectives.*

83. The nature of *verbs* and *participles* being understood, that of *ADJECTIVES* becomes easy. A *verb* implies (as we have said) an *attribute*, *time*, and an *assertion*; a *participle* implies only an *attribute* and *time*; and an *ADJECTIVE* implies only an *attribute as belonging to some substance*. In other words, an *ADJECTIVE* has *no assertion*, and it denotes *only such an attribute as has not its essence either in motion or its privation*. Thus, in general, the attributes of *quantity*, *quality*, and *relation*, such as *many*, *few*, *great*, *little*, *black*, *white*, *good*, *bad*, *double*, *treble*, &c. are all denoted by *ADJECTIVES*.

84. To understand the import and the use of this species of words, it must be observed that every *adjective* is resolvable into a *substantive* and an *expression of connection* equivalent to *of*. Thus, a *good man* is a *man of* other with *goodness*; where we see the *attribute* denoted by the *adjective* fully expressed by an *abstract noun*. But it is

Adjectives. evident that the *noun* *goodness* does not express the *whole* meaning of the *adjective* *good*; for every *adjective* expresses not only an *attribute*, but also the *connection* between the *attribute* and its *substance*; whereas in the *abstract noun*, the *attribute* is considered as a *substance* unconnected with any other substance.

In the next place it is to be observed, that the *connection* expressed by *adjectives*, like that expressed by *of*, is of a nature so *general* and *indefinite*, that the particular *kind* of connection must, in some languages, be inferred from our previous knowledge of the objects between which it subsists, or it will for ever remain unknown. This might be proved by a variety of examples, but will perhaps be sufficiently evident from the following. *Color salubris* signifies colour that *indicates* health; *exercitatio salubris*, exercise that *preserves* health; *victus salubris*, food that *improves* health; *medicina salubris*, medicine that *restores* health. In all these examples the *connection* expressed by the adjective form of *salubris* is different; and though it may be known from *previous experience*, there is nothing in any of the expressions themselves by which it can be ascertained. Thus, adjectives are each significant of an *attribute* and *connection*; but the particular *kind* of connection is ascertained by experience.—The usual effect of *adjectives* in language, is to *modify* or *particularize* a *general term*, by adding some *quality* or *circumstance* which may distinguish the object *meant* by that term, from the *other* objects of the *same species*. I have occasion, for example, to speak of a particular man, of whose name I am ignorant. The word *man* is too general for my purpose, it being applicable to *every individual* of the human species. In what way then do I proceed, in order to particularize it, so as to make it denote *that very man* whom I mean to *specify*? I annex or conjoin to it such words as are significant of *objects* and *qualities* with which *he is connected*, and which are not equally applicable to *others* from whom I mean to *distinguish him*. Thus I can say, a *man of prudence* or a *prudent man*, a *wise man*, a *good man*, a *brave man*, &c. By these additions the general term *man* is limited, or modified, and can be applied only to *certain men* to whom belong the *attributes* expressed by the *adjectives* *prudent*, *wise*, *good*, and *brave*. If it be still too general for my purpose, I can add to it other qualities and circumstances, till I make it so particular as to be applicable to but *one individual man* in the universe.

93 The usual effect of adjectives is to modify a general term.

85. This is the way in which **ADJECTIVES** are commonly used, but this is not the *only* way. Instead of being employed to *modify* a *substantive*, they sometimes appear as the *principal words* in the sentence, when the sole use of the *substantive* seems to be to modify the *abstract noun*, contained under the *adjective* to which that *substantive is joined*. In order to understand this, it will be necessary to attend to the following observations.

94 The reverse of this is sometimes the case.

It may be laid down as a general proposition, that when any term or phrase is employed to denote a *complex conception*, the mind has a power of considering, in what order it pleases, the *simple ideas* of which the *complex conception* is composed. To illustrate this observation by an example: The word *eques* in Latin denotes a *complex conception*, of which the *constituent simple ideas* are those of a *man* and a *horse*; with this *connection* subsisting between them, that the *man* is conceived as on the *back of the horse*. In the use of this word, it is

well known that the *idea first* in order, as being the *principal subject* of the proposition, is commonly *the MAN on the back of the horse*; but it is not so always, for the mind may consider the *HORSE* as the principal object. Thus when Virgil says,

*Fræna Pelethronii Lapithæ gyrosque dedere,
Impositi dorso; atque EQUITEM docuere sub armis
INSULTARE SOLO, et GRESSUS GLOMERARE superbos—*

the energies attributed to the object signified by **EQUITEM**, make it evident that the *horse* and not the *man* is meant; for it is not the property of a *man*, *insultare solo, et gressus glomerare superbos*.

The same observation holds true where the *complex object* is denoted by two or more words; an *adjective*, for instance, and a *substantive*. Thus in the phrase *summus mons se inter nubila condit*, the words *summus mons* represent a *complex conception*, of which the constituent ideas are those of *height* and *mountain*, connected together by the *adjective* form of *summus*. Either of these ideas may be the subject of the proposition; and the expression will accordingly admit of two different significations. If *mons* be made the subject of the proposition, the meaning will be, "the highest mountain hides itself among the clouds." If the *substantive* included in the radical part of *summus* be made the subject of the proposition, the expression will signify, "the summit, or highest part of the mountain, hides itself among the clouds." The latter is the true import of the sentence.

86. From these observations and examples, we shall be enabled to understand the *two uses* of the *adjective*. It is either employed, as has been already observed, to *restrict* or *modify*, a *general term*; or the *abstract substantive* contained in the *adjective* is modified by the *noun*, with which, in the concrete or adjective form, that *abstract substantive* is joined. The first may be called the *direct*, the second the *inverse*, acceptation of adjectives.

The *inverse* acceptation of *adjectives* and *participles* (for both are used in the same manner) has not, except in a very few instances, been noticed by any *grammarian*; yet the principle is of great extent in language. In order to explain it, we shall produce a few examples; which on any other principle it is impossible to understand.

Evry, speaking of the abolition of the regal authority at Rome, says, *Regnum est Romæ ab URBE CONDITA ad LIBERATAM annos ducentos quadraginta quatuor*, "Monarchy subsisted at Rome, not from the city built (which would convey no meaning), but from the building of the city, to its deliverance;" &c. Both the participles *condita* and *liberata* are here used *inversely*; that is, the *abstract substantives* contained in *condita* and *liberata* are modified or restricted by the substantives *urbe* and *urbem*, with which they unite. Again, *Ovid*, speaking of the contest between *Ajax* and *Ulysses* for the arms of *Achilles*, has these lines:

*Qui, licet cloquio filum quoque Nestora vincat,
Haud tamen efficiet, DESERTUM ut NESTORA CRIMEN
Nullum esse rear.*

Here also the *adjective* or *participle* **DESERTUM** is taken inversely, and the *general notion* of *desertion* contained in it is *modified* or rendered *particular* by being joined with the substantive **NESTORA**. The meaning of the passage

Adjectives. passage is, "I will never be induced to believe that the desertion of Nestor was not a crime." Were *desertum* to be taken directly as an adjective modifying its substantive, the sentence must be translated, "I cannot believe that Nestor deserted was not a crime." But it is evident that this is nonsense: as NESTOR, whether deserted or not deserted, could not be a crime.

It were easy to produce many more examples of adjectives taken *inversely*; but these may suffice to illustrate the general principle, and to show, that without attending to it, it is impossible to understand the ancient authors. We shall adduce one instance of it from Shakespeare, to evince that it is not confined to the ancient languages, though in these it is certainly more frequent than in the moderns:

"Freeze, freeze, thou bitter sky;
 "Thou canst not bite so nigh
 "As benefits forgot:
 "Though thou the waters warp,
 "Thy sting is not so sharp
 "As friends remember'd not."

Here it is evident, that the adjective FORGOT is taken *inversely*; for it is not a benefit, but the forgetting of a benefit, which bites more than the bitter sky: and therefore, in this passage, the adjective serves not to modify the noun; but the noun *benefits* is employed to modify the abstract substantive contained in the adjective *forgot*, which is the subject of the proposition, and the principal word in the sentence.

Had Mr Harris attended to the principle, and reflected upon what he could not but know, that all adjectives denote substances; not indeed subsisting by themselves, as those expressed by nouns, but concretely, as the attributes of other substances; he would not have classed adjectives with verbs, or have passed so severe a censure upon the grammarians for classing them with nouns. It matters very little how adjectives are classed, provided their nature and effect be understood; but they have at least as good a title to be ranked with nouns as with verbs, and in our opinion a better. To adopt Mr Harris's language, they are homogeneous with respect to nouns, as both denote substances; they are heterogeneous with respect to verbs, as they never do denote assertion.

87. Besides original adjectives, there is another class, which is formed from substantives. Thus, when we say, *the party of Pompey, the style of Cicero, the philosophy of Socrates*; in these cases, the party, the style, and the philosophy spoken of, receive a stamp and character from the persons whom they respect: Those persons, therefore, perform the part of attributes. Hence they actually pass into attributives, and assume as such the form of adjectives. It is thus we say, *the Pompeian party, the Ciceronian style, and the Socratic philosophy*. In like manner, for a trumpet of brass, we say a brazen trumpet, and for a crown of gold, a golden crown, &c. Even pronominal substantives admit the like mutation. Thus, instead of saying the book of me, and of thee, we say my book, and thy book; and instead of saying, the country of us, and of you, we say our country, and your country. These words *my, thy, our, your, &c.* have therefore been properly called pronominal adjectives.

88. It has been already observed, and must be obvious to all, that substances alone are susceptible of sex; and that therefore substantive nouns alone should have distinctions respecting gender. The same is true with respect to number and person. An ATTRIBUTE admits of no change in its nature, whether it belong to YOU or to ME, to a MAN or a WOMAN, to ONE man or to MANY; and therefore the words expressive of attributes, ought on all occasions, and in every situation, to be fixed and invariable. For as the qualities good and bad, black and white, are the same, whether they be applied to a man or a woman, to many or to few; so the word which expresses any one of these attributes ought in strictness to admit of no alteration with whatever substantive it may be joined. Such is the order of nature; and that order, on this as on other occasions, the English language most strictly observes: for we say equally, a good man or a good woman; good men or good women; a good house or good houses. In some languages, indeed, such as Greek and Latin, of which the nouns admit of cases, and the sentences of an inverted structure, it has been found necessary to endow adjectives with the threefold distinction of gender, number, and person; but as this is only an accidental variation, occasioned by particular circumstances, and not in the least essential to language, it belongs not to our subject, but to the particular grammars of these tongues.

There is, however, one variation of the adjective, which has place in all languages, is founded in the nature of things, and properly belongs to universal grammar. It is occasioned by comparing the attribute of one substance with a similar attribute of another, and falls naturally to be explained under the next section.

SECT. III. Of Adverbs, and the Comparison of Adjectives.

89. As adjectives denote the attributes of substances, so there is an inferior class of words which denote the modifications of these attributes. Thus, when we say "Cicero and Pliny were both of them eloquent; Statius and Virgil both of them wrote;" the attributes expressed by the words *eloquent* and *wrote* are immediately referred to Cicero, Virgil, &c.; and as denoting the attributes of substances, these words, the one an adjective, and the other a verb, have been both called ATTRIBUTIVES OF THE FIRST ORDER. But when we say, "Pliny was moderately eloquent, but Cicero exceedingly eloquent; Statius wrote indifferently, but Virgil wrote admirably;" the words *moderately, exceedingly, indifferently, and admirably*, are not referable to substantives, but to other attributes; that is, to the words *eloquent* and *wrote*, the signification of which they modify. Such words, therefore, having the same effect upon adjectives that adjectives have upon substantives, have been called ATTRIBUTIVES OF THE SECOND ORDER. By grammarians they have been called ADVERBS; and, if we take the word VERB in its most comprehensive signification (A), as including not only verbs properly so called, but also every species of words, which, whether essentially or accidentally, are significant of the attributes of substances, we shall find the name ADVERB to

(A) Aristotle and his followers called every word a verb, which denotes the predicate of a proposition. This classification was certainly absurd; for it confounds not only adjectives and participles, but even substantives, with verbs: but the authority of Aristotle was great; and hence the name of adverb, though that word attaches itself only to an adjective or participle, or a verb significant of an attribute: it does not attach itself to the pure verb.

96
 Adjectives
 formed
 from sub-
 stantives.

97
 and from
 pronouns.

Adverbs,
 &c.

98
 Adjectives
 from their
 nature
 should have
 no varia-
 tion to de-
 note sex,
 number, or
 person.

99
 They have
 however
 one varia-
 tion found-
 ed in the
 nature of
 things.

100
 The import
 of adverbs.

101
 The reason
 of their
 names.

Adverbs,
&c.

to be a very just appellation, as denoting A PART OF SPEECH, THE NATURAL APPENDAGE OF SUCH VERBS. So great is this dependence in grammatical syntax, that an *adverb* can no more subsist without its *verb*, i. e. without *some word* significant of an *attribute*, than a *verb* or *adjective* can subsist without its *substantive*. It is the same here as in certain natural subjects. Every *colour*, for its existence, as much requires a *superficies*, as the *superficies* for its existence requires a *solid body*.

102
Adverbs
denoting
intension
and remis-
sion.

99. Among the attributes of substance are reckoned *quantity* and *quality*: thus we say a *white garment*, a *high mountain*, &c. Now some of these quantities and qualities are capable of *intension* or *remission*; or, in other words, *one substance* may have them in a *greater* or *less degree* than another. Thus we say, a *garment EXCEEDINGLY white*, a *mountain TOLERABLY* or *MODERATELY high*. Hence, then, one copious source of *secondary attributes* or *ADVERBS* to denote these two, that is, *intension* and *remission*; such as *greatly*, *tolerably*, *vastly*, *extremely*, *indifferently*, &c.

103
Attributes
of the same
kind com-
pared by
means of
such ad-
verbs.

But where there are different intensions of the same attribute, they may be compared together: Thus, if the garment A be *EXCEEDINGLY white*, and the garment B be *MODERATELY white*, we may say, the garment A is *MORE white* than the garment B. This *paper* is *white*, and *snow* is *white*; but *snow* is *MORE white* than this paper. In these instances, the adverb *MORE* not only denotes *intension*, but *relative intension*: nay, we stop not here, as we not only denote *intension merely relative*, but *relative intension than which there is none greater*. Thus we say, *Sophocles was wise*, *Socrates was MORE wise* than he, but *Solomon was the MOST wise* of men. Even *verbs*, properly so called, which denote an *attribute* as well as an *assertion*, must admit both of *simple* and also of *comparative intensions*; but the *simple verb TO BE* admits of neither the one nor the other. Thus, in the following example, *Fume he LOVETH MORE than riches*; but *virtue of all things he LOVETH MOST*; the words *MORE* and *MOST* denote the different *comparative intensions* of the *attribute* included under the verb *loveth*; but the *assertion* itself, which is the *essential part* of the *verb*, admits neither of *intension* nor *remission*, but is the same in all possible propositions.

104
The com-
parison of
adjectives,
either by
adverbs,

91. From this circumstance of *quantities* and *qualities* being capable of *intension* and *remission*, arise the *COMPARISON* of *adjectives*, and its different *DEGREES*, which cannot well be more than the two species above mentioned; one to denote *simple excess*, and one to denote *superlative*. Were we indeed to introduce more degrees than these, we ought perhaps to introduce *infinite*, which is absurd. For why stop at a limited number, when in all subjects susceptible of *intension*, the intermediate excesses are in a manner infinite? Between the first *simple white* and the *superlative whitest*, there are infinite degrees of *more white*; and the same may be said of *more great*, *more strong*, *more minute*, &c. The doctrine of grammarians about *three* such degrees of comparison, which they call the *positive*, the *comparative*, and the *superlative*, must be absurd; both because in their *positive* there is no *comparison* at all, and because their *superlative* is a *comparative* as much as their *comparative* itself. Examples to evince this may be met with everywhere: *Socrates was the MOST wise of all the Athenians*; *Homer was the MOST SUBLIME of all poets*, &c. In this

sentence *Socrates* is evidently compared with the *Athenians*, and *Homer* with all other poets. Again, if it be said that *Socrates was MORE wise than any other Athenian*, but that *Solomon was the MOST wise of men*; is not a comparison of *Solomon* with *mankind* in general, as plainly implied in the last clause of the sentence, as a comparison of *Socrates* with the *other Athenians* in the first?

Adverbs,
&c.

But if both imply comparison, it may be asked, In what consists the difference between the *comparative* and *superlative*? Does the *superlative* always express a *greater excess* than the *comparative*? No: for though *Socrates was the most wise of the Athenians*, yet is *Solomon* affirmed to have been *more wise* than he; so that here a *higher superiority* is denoted by the *comparative more* than by the *superlative most*. Is this then the difference between these two degrees, that the *superlative* implies a comparison of *one with many*, while the *comparative* implies only a comparison of *one with one*? No: this is not always the case neither. The Psalmist says, that "he is *wiser* (or *more wise*) than all his teachers;" where, though the *comparative* is used, there is a comparison of *one with many*. The real difference between these two degrees of comparison may be explained thus:

When we use the *superlative*, it is in consequence of having compared *individuals* with the *species* to which they belong, or one or more *species* with the *genus* under which they are comprehended. Thus, *Socrates was the MOST wise of the Athenians*, and *the Athenians were the MOST ENLIGHTENED of ancient nations*. In the first clause of this sentence, *Socrates*, although compared with the *Athenians*, is at the same time considered as *one of them*; and in the last, the *Athenians*, although compared with *ancient nations*, are yet considered as *one of those nations*. Hence it is that in *English* the *superlative* is followed by the preposition *of*, and in *Greek* and *Latin* by the *genitive case* of the *plural number*; to show, that the object which has the pre-eminence is considered as *belonging to that class* of things with which it is compared.

But when we use the *comparative degree*, the objects compared are set in *direct opposition*; and the one is considered *not* as a *part of the other*, or as *comprehended* under it, but as something altogether *distinct* and *belonging to a different class*. Thus, were one to say, "Cicero was *more eloquent* than the Romans," he would speak absurdly; because every body knows, that of the class of men expressed by the word *Romans* Cicero was one, and such a sentence would affirm that orator to have been more eloquent than himself. But when it is said that "Cicero was *more eloquent* than all the other Romans, or than any other Roman," the language is proper, and the affirmation true: for though the persons spoken of were all of the same class or city, yet Cicero is here set in *contradistinction* to the rest of his countrymen, and is not considered as *one of the persons* with whom he is compared. It is for this reason that in *English* the *comparative degree* is followed by a noun governed by the word of *contradistinction* *than*, and in *Latin* by a noun in the *ablative case* governed by the preposition *præ* (B) either expressed or understood. We have already observed, that the *ablative case* denotes *concomitancy*: and therefore when

an

(B) See *Ruddimanni Grammaticæ Institutiones, Pars secunda, lib. i. cap. 2.*

Although it is certainly true, that when we use the *superlative*, we ought in propriety to consider the things compared

Adverbs, &c.

an adjective in the comparative degree is prefixed to a noun, that noun is put in the *ablative case*, to denote that two things are compared together in *company*; but by means of the preposition, expressed or understood, that which is denoted by the *comparative adjective* is seen to be preferred *before* that which is denoted by the *noun*.

92. We have hitherto considered *comparatives* as expressed by the words *more* and *most*; but the authors, or improvers of language, have contrived a method to retrench the use of these *adverbs*, by expressing their force by an *inflection of the adjective*. Thus, instead of *more fair*, they say FAIRER; instead of *most fair*, FAIREST: and the same method of comparison takes place both in the Greek and Latin languages; with this difference, however, between the genius of these languages and ours, that we are at liberty to form the comparison either in the one method or in the other; whereas in those languages the comparison is seldom if ever formed by the assistance of the adverb, but always by the inflection of the adjective. Hence this inflection is by the Greek and Latin grammarians considered as a *necessary accident of the adjective*; but it has reached no farther than to *adjectives*, and *participles sharing the nature of adjectives*. The attributes expressed by *verbs* are as susceptible of comparison as those expressed by *adjectives*; but they are always compared by means of *adverbs*, the *verb* being too much diversified already to admit of more variations without perplexity.

93. It must be confessed that *comparatives*, as well the *simple* as the *superlative*, seem sometimes to part with their *relative nature*, and to retain only their *intensive*. Thus in the degree denoting *simple excess*:

TRISTIOR, et lacrymis oculos suffusa nitentes. VIRG.

Tristior means nothing more than that *Venus* was *very sad*. In the degree called the *superlative* this is more usual. Phrases extremely common are, *Vir doctissimus, vir fortissimus*, "a most learned man, a most brave man;" i. e. *not the bravest and most learned man that ever existed*, but a man possessing those qualities in an *eminent degree*. In English, when we intimate that a certain quality is possessed in an eminent degree, without making any *direct comparison* between it and a similar quality, we do it by the *intensive word very*, more commonly than by *most*: as, *Cicero was VERY eloquent; the mind of Johnson was VERY vigorous*. This mode of expression has been called the *superlative of eminence*, to distinguish it from the *other superlative*, which is *superlative upon comparison*. Yet it may be said, that even in

the *superlative of eminence* something of *comparison* must be *remotely or indirectly* intimated, as we cannot reasonably call a man *very eloquent*, without comparing *his* eloquence with the eloquence of *other men*. This is indeed true; but we cannot therefore affirm that *comparison* is more clearly intimated in *this superlative* than in the *simple adjective eloquent*: for when we say that a man is *eloquent*, we mark between *his* eloquence and that of *other men* a distinction of the same *kind*, though not in the same *degree*, as when we say that he is *very eloquent*.

In English we distinguish the two superlatives, by prefixing to the *one* the definite article *the*, to show that something is predicated of the object expressed by it, which cannot be predicated of *any other* object; and by subjoining the preposition *of*, to show that the objects with which it is compared are of the same class with itself: as, "Solomon was *the wisest of men*; Hector was *the most valiant of the Trojans*." To the other (c) superlative we only prefix the indefinite article *a*: as, "he was *a very good man*: he was *a most valiant soldier*."

94. As there are some *qualities* which admit of *comparison*, so there are others which admit of none: such, for example, are those which denote that *quality of bodies arising from their figure*; as when we say, a *circular table*, a *quadrangular court*, a *conical piece of metal*, &c. The reason is, that a million of things participating the same figure, participate it *equally*, if they do it at all. To say, therefore that while A and B are both *quadrangular*, A is *more or less* quadrangular than B, is absurd. The same holds true in all attributives denoting *definite quantities* of whatever nature: for as there can be no comparison without *intension or remission*, and as there can be no intension or remission in *things always definite*, therefore these attributives can admit of no comparison. By the same method of reasoning, we discover the cause why no *substantive is susceptible of these degrees of comparison*. A *mountain* cannot be said *MORE TO BE OR TO EXIST* than a *mole-hill*; but the *more or less* must be sought for in their quantities. In like manner, when we refer many individuals to one species, the lion A cannot be called *more a lion* than the lion B (D); but if more any thing, he is *more fierce, more swift*, or exceeding in some such attribute. So again, in referring many species to one genus, a crocodile is not *more an animal* than a lizard; nor a tiger more than a cat; but, if any thing, the crocodile and tiger are *more bulky, more strong*, &c. than the animals with which they are compared; the excess, as before, being derived from their attributes.

Adverbs, &c.

105
r by in-
crease.

107
Adjectives
which ad-
mit not of
degrees of
compari-
son.

106
Comparatives sometimes lose their relative nature.

compared as of the same class; and when we use the *comparative*, as of different classes; yet is not this *distinction* always attended to by the best writers in any language. In Latin and Greek the *comparative* is sometimes used, where in English we should use the *superlative*; as *dextra est fortior manuum*; and in the Gospel it is said, that "a grain of mustard-seed is the *smaller* (*μικροτέρως*) of all seeds, but when grown up it is the *greater* (*μεγίστην*) of herbs." Even in English, the custom of the language permits us not to say "he is the *tallest* of the two," it must be the *taller* of the two; but we cannot say "he is the *taller* of the *three*," it must be the *tallest*. For these and other deviations from the general rule no reason is to be found in the nature of things; they are errors made proper by use.

(c) In English, the termination *est* is peculiar to the superlative of *comparison*, to which the *definite article* is prefixed. Thus we may say, "Homer was *the sublimest of poets*;" but we cannot say, "Homer was *a sublimest poet*." Again, we may say "Homer was *a very sublime poet*;" but not, "Homer was *the very sublime poet*."

(d) When Pope says of a certain person, that he is "a tradesman, meek, and *much a liar*;" the last phrase is the same with *much given to lying*, the word *liar* having the effect of an *attributive*.

Adverbs,
&c.
103
Adverbs
divided in-
to classes.

95. Of the *adverbs* or *secondary attributives* already mentioned, those denoting *intension* and *remission* may be called ADVERBS of QUANTITY CONTINUOUS, as *greatly*, *vastly*, *tolerably*, &c. *once*, *twice*, *thrice*, &c. (E) are ADVERBS of QUANTITY DISCRETE; *more* and *most*, *less* and *least*, to which may be added *equally*, *proportionally*, &c. are ADVERBS of RELATION. There are others of QUALITY: as when we say, *HONESTLY industrious*, *PRUDENTLY brave*; *they fought BRAVELY*, *he painted FINELY*.

And here it may be worth while to observe, how the same thing, participating the same essence, assumes different grammatical forms from its different relations. For example, suppose it should be asked, How differ *honest*, *honestly*, and *honesty*? The answer is, They are in essence the same: but they differ in as much as *honest* is the *attributive* of a *noun*; *honestly*, of *verb* or *adjective*; and *honesty* being divested of these its attributive relations, assumes the power of a *noun* or *substantive*, so as to stand by itself.

96. The adverbs hitherto mentioned are common to *verbs* of every species; but there are some which are confined to *verbs* properly so called, that is, to such verbs as denote *motions* or *energies* with their *privations*. All *motion* and *rest* imply *time* and *place* as a kind of necessary coincidence. Hence, when we would express the place or time of either, we have recourse to *adverbs* formed for this purpose; of PLACE, as when we say, *he stood THERE*, *he went HENCE*, *he came HITHER*; of time, as when we say, *he stood THEN*, *he went AFTERWARDS*, *he travelled FORMERLY*. To these may be added the adverbs which denote the *intensions* and *remissions peculiar* to *MOTION*, such as *speedily*, *hastily*, *swiftly*, *slowly*, &c.; as also adverbs of *place* made out of *prepositions*, such as *upward* and *downward* from *up* and *down*. It may, however, be doubted whether some of these words, as well as many others which do not so properly *modify* attributes, as mark some *remote circumstance* attending an attribute or our way of conceiving it, are truly *adverbs*, though so called by the grammarians. The simple *affirmative* and *negative* YES and NO are called *adverbs*, though they surely do not signify that which we hold to be the very essence of the adverb, a *modification of attributes*. "Is he learned? No." "Is he brave? Yes." Here the two adverbs, as they are called, signify *not* any *modification* of the attributes *brave* and *learned*, but a total negation of the attribute in the one case, and in the other a declaration that the attribute belongs to the person spoken of.

Adverbs are indeed applied to many purposes; and their general nature may be better understood by reading a list of them, and attending to their etymology, than by any general description or definition. Many of them seem to have been introduced into language in order to express by *one word* the meaning of two or three; and are mere abbreviations of *nouns*, *verbs*, and *adjectives*. Thus, the import of the phrase, *in what place*, is expressed by the single word *WHERE*; *so what place*, by *WHITHER*; *from this place*, by *HENCE*; *in a direction ascending*, by *UPWARDS*; *at the present time*, by *NOW*; *at what time*, by *WHEN*; *at that time*, by *THEN*; *many times*, by *OFTEN*; *not many times*, by *SELDOM*, &c.

97. Mr *Horne Tooke* has, with great industry and accuracy, traced many of the English adverbs from their origin in the ancient Saxon and other northern tongues, and shown them to be either corruptions of other words or abbreviations of phrases and sentences. He observes, "that all adverbs ending in *LY*, the most prolific branch of the family, are sufficiently understood: the termination being only the word *like* corrupted; and the corruption so much the more easily and certainly discovered, as the termination remains more pure and distinguishable in the other sister languages, in which it is written *kick*, *lyk*, *lig*, *tigen*." He might have added, that in Scotland the word *like* is, at this day, frequently used instead of the English termination *ly*; as for a *goodly figure*, the common people say a *good-like figure*. Upon this principle the greater part of *adverbs* are resolved into those parts of speech which we have already considered, as *honestly* into *honest-like*, *vastly*, into *vast-like*, &c. so that when we say of a man he is *honestly industrious*, we affirm that he is *honest-like industrious*, or that his *industry* has the *appearance* of being *honest*. *Adverbs* of a different termination the same acute writer resolves thus; AGHAST into the past participle AGAZED;

"The French exclaimed,—the devil was in arms.
"All the whole army stood *agazed* on him." SHAKESP.

AGO, into the past participle AGONE or GONE. ASUNDER he derives from ASUNDERED, *separated*; the past participle of the Anglo-Saxon verb *asundrian*: a word which, in all its varieties, is to be found, he says, in all the northern tongues; and is originally from *sand*, i. e. *sand*. TO WIT, from WITTAN *to know*; as *videlicet* and *scilicet*, in Latin, are abbreviations of *videre-licet* and *scire-licet*. NEEDS, he resolves into NEED IS, used parenthetically; as, "I must *needs* do such a thing."—"I must (need is) do such a thing;" i. e. "I must do it, there is *need* of it." ANON, which our old authors use for *immediately*, *instantly*, means, he says, *in one*; i. e. *in one instant, moment, minute*. As,

"And right anon withouten more abode."
"Anon in all the haste I can."

ALONE and ONLY are resolved into ALL ONE, and ONE-LIKE. In the Dutch, EEN is *one*; and ALL EEN *alone*; and ALL-EEN-LIKE, *only*, anciently *abouely*. ALIVE is *on live*, or *in life*. Thus,

"Christ eterne *on live*." CHAUCER.

AUGHT or OUGHT; A WHIT or O WHIT; O being formerly written for the article A, or for the numeral ONE; and *whit* or *hwit*, in Saxon, signifying a small thing, as a *point* or *dot*. AWHILE, which is usually classed with *adverbs*, is evidently a *noun* with the indefinite article prefixed; a *while*, i. e. a *time*. WHILST, anciently and more properly WHILES, is plainly the Saxon HWILE-ES, *time that*. ALOFT was formerly written ON-LOFT: As,

"And ye, my mother, my soveregne pleassance
"Oyer al thing, *out take* Christ ON LOFTE." CHAUCER.

Now, says Mr *Horne Tooke*, *lyft*, in the Anglo Saxon, is

(E) These words were anciently written *one's*, *twie's*, *thrie's*; and are merely the genitives of *one*, *two*, *three*, the substantive *time* or *turn* being omitted. Thus, *How often did you write?* Answer, *Once*, i. e. *one's time*. See *Horne Tooke's Diversions of Purley*.

Verbs. *is the air or the clouds*, as IN LYFTE CUMMENDE, *coming in the clouds* (St Luke). In the Danish, LUFT is *air*; and "at spronge i lufften," *to blow up into the air*, or ALOFT. So in the Dutch, *de loef hebben*, *to sail before the wind*; *loeven*, *to ply to windward*; *loef*, *the weather vane*, &c. From the same root are our other words; *Loft*, *lofty*, *to luff*, *lee*, *leeward*, *lift*, &c. It would be needless, as the ingenious author observes, to notice such adverbs as, *afoot*, *adays*, *ashore*, *astray*, *askope*, *aright*, *abed*, *aback*, *abreast*, *afloat*, *aloud*, *aside*, *afield*, *aground*, *aland*, &c. These are at first view seen for what they are. Nor shall we follow him through the analysis which he has given of many other adverbs, of which the origin is not so obvious as of these. Of the truth of his principles we are satisfied; and have not a doubt, but that upon those principles a man conversant with our earliest writers, and thoroughly skilled in the present languages, may trace every English (s) adverb to its source, and show that it is no part of speech separate from those which we have already considered. The adverbs, however, of affirmation and negation, are of too much importance to be thus passed over; and as we have never seen an account of them at all satisfactory, except that which has been given by Horne Tooke, we shall transcribe the substance of what he says concerning AYE, YEA, YES, and NO. To us these words have always appeared improperly classed with adverbs upon every definition which has been given of that part of speech. Accordingly, our author says, that AYE or YEA is the imperative of a verb of northern extraction; and means, *have*, *possess*, *enjoy*. And YES is a contraction of AY-ES, *have*, *possess*, *enjoy*, *that*. Thus, when it is asked whether a man be learned, if the answer be by the word YES, it is equivalent to *have that*, *enjoy that*, *believe that* proposition. (See what was said of the nature of interrogation, Chap. IV. N^o 76.)

The northern verb of which *yea* is the imperative, is in Danish EJER, *to possess*, *have*, *enjoy*. EJA, *aye* or *yea*; EJE, *possession*; EJER, *possessor*. In Swedish it is EGA, *to possess*; of which the imperative is JA, *aye*, *yea*: EGARE, *possessor*. In German, JA signifies *aye*, or *yea*; EIGENER, *possessor*, *owner*; EIGEN, *own*. In Dutch, EIGENEN is *to possess*; JA, *yea*.

Greenwood derives NOT and its abbreviation NO from the Latin; Minshow, from the Hebrew; and Junius, from the Greek. Our author very properly observes, that the inhabitants of the north could not wait for a word expressive of dissent till the establishment of those nations and languages: and adds, that we need not be inquisitive nor doubtful concerning the origin and signi-

fication of NOT and NO; since we find that, in the Danish NODIG, in the Swedish NODIG, and in the Dutch, NOODE, NODE, and NO, mean *averse*, *unwilling*. So that when it is asked whether a man be brave, if the answer be NO, it is a declaration that he who makes it is *averse from* or *unwilling to admit* that proposition.

98. Most writers on grammar have mentioned a species of adverbs, which they call *adverbs of interrogation*, such as *where*, *whence*, *whither*, *how*, &c. But the truth is, that there is no part of speech, which, of itself, denotes interrogation. A question is never asked otherwise than by *abbreviation*, by a *single word*, whether that word be a *noun*, a *pronoun*, a *verb*, or an *adverb*. The word WHERE is equivalent to—*in what place*; WHENCE to—*from what place*; and HOW to—*in what manner*, &c. In these phrases, IN *what place*, FROM *what place*, and IN *what manner*, the only word that can be supposed to have the force of an *interrogative*, is *what*, which is resolvable into *that which*: But we have already explained, in the chapter of *Pronouns*, the principles upon which the *relative* is made to denote interrogation, and the same reasoning will account for the adverbs *where*, *whence*, *whither*, *how*, &c. being employed as *interrogatives*. When we say, *where were you yesterday?* *whence have you come?* *whither are you going?* *how do you perform your journey?* We merely use so many *abbreviations* for the following sentences; *tell us*, or *describe to us*, THE PLACE *where* (or in which) *you were yesterday*; THE PLACE *whence* (or from which) *you have come*; THE PLACE *to which* *you are going*; THE MANNER *in which* *you perform your journey*? And so much for *adverbs*. We now proceed to those parts of speech which are usually called *prepositions* and *conjunctions*, and of which the use is to connect the other words of a sentence, and to combine two or more *simple sentences* into *one compound sentence*.

CHAP. VI. Of Prepositions, Conjunctions, and Interjections.

99. It has been observed, that a man while awake is conscious of a continued train of perceptions and ideas passing in his mind, which depends little upon his own will; that he cannot to the train add a new idea; and that he can but very seldom break its connexion. To the slightest reflection these truths must be apparent. Our first ideas are those which we derive from external objects making impressions on the senses; but all the external objects which fall under our observation are linked together in such a manner as indicates them to be parts of one great and regular system

(s) The same resolution might probably be made of the Greek and Latin adverbs, were we as intimately acquainted with the sources of those tongues as Mr Horne Tooke is with the sources of the English language. "Many of the Latin adverbs (says the learned Ruddiman) are nothing else but *adjective nouns* or *pronouns*, having the *preposition* and *substantive* understood; as, *quo*, *co*, *eodem*, for *ad quæ*, *eu*, *eadem* (*loca*) or *cui*, *ei*, *eidem* (*loco*); for of old these datives ended in o. Thus, *qua*, *hac*, *illac*, &c. are plainly adjectives in the *abl. sing. Femin.* the word *via*, "a way," and the preposition *in*, being understood. Many of them are compounds; as, *quomodo*, i. e. *quo modo*; *quemadmodum*, i. e. *ad quem modum*; *quamobrem*, i. e. *ob quam rem*; *quare*, i. e. (*pro*) *qua re*; *quorum*, i. e. *versus quem* (*locum*); *scilicet*, i. e. *scire licet*; *videlicet*, i. e. *videre licet*; *ihcet*, i. e. *ire licet*; *illico*, i. e. *in loco*; *magno opere*, i. e. *magno opere*; *nimirum*, i. e. *ni (est) mirum*; *hodie*, i. e. *hoc die*; *postridie*, i. e. *postero die*; *pridie*, i. e. *præ die*. *Perfecto*, *certe*, *sane*, *male*, *bene*, *plane*, are obviously adjectives. *Forte* is the ablative of *fors*; and if we had leisure to pursue the subject, and were masters of all the languages from which the Latin is derived, we doubt not but we should be able to resolve every adverb into a *substantive* or *adjective*.

Prepositions, &c.
112
by various relations:

system. When we take a view of the things by which we are surrounded, and which are the archetypes of our ideas, their inherent qualities are not more remarkable than the various relations by which they are connected. Cause and effect, contiguity in time or in place, high and low, prior and posterior, resemblance and contrast, with a thousand other relations, connect things together without end. There is not a single thing which appears solitary and altogether devoid of connexion. The only difference is, that some are intimately and some slightly connected, some nearly and some at a distance. That the relations by which external objects are thus linked together must have great influence in directing the train of human thought, so that not one perception or idea can appear to the mind wholly unconnected with all other perceptions or ideas, will be admitted by every man who believes that his senses and intellect represent things as they are.

This being the case, it is necessary, if the purpose of language be to communicate thought, that the speaker be furnished with words, not only to express the ideas of substances and attributes which he may have in his mind, but also to indicate the order in which he views them, and to point out the various relations by which they are connected. In many instances all this may be done by the parts of speech which we have already considered. The closest connexion which we can conceive is that which subsists between a substance and its qualities; and in every language with which we are acquainted, that connexion is indicated by the immediate coalescence of the adjective with the substantive; as we say, a good man, a learned man; *vir bonus, vir doctus*. Again, there is a connection equally intimate, though not so permanent, between an agent and his action: for the action is really an attribute of the agent; and therefore we say, the boy reads, the man writes; the noun coalescing with the verb so naturally, that no other word is requisite to unite them. Moreover, an action and that which is acted upon being contiguous in nature, and mutually affecting each other, the words which denote them should in language be mutually attractive, and capable of coalescing without external aid; as, he reads a book, he builds a house, he breaks a stone. Further; because an attribute and its modifications are inseparably united, an adjective or a verb is naturally connected with the adverb which illustrates or modifies its signification; and therefore, when we say, he walks slowly, he is prudently beaver, it is plain that no other word is necessary to promote the coalescence of the attributes walking and bravery with their modifications of slowness and prudence. The agreement between the terms of any proposition which constitutes truth is absolutely perfect; but as either of the terms may agree with many other things besides its correlate, some word is requisite in every proposition to connect the particular predicate with the particular subject: and that is the office of the simple verb TO BE; as, the three angles of every triangle ARE equal to two right angles.

Thus we see, that many of the relations subsisting between our ideas may be clearly expressed by means of nouns, adjectives, verbs, and adverbs; and in those languages of which the nouns have cases, there is perhaps no relation of much importance which might not be thus pointed out, without being under the necessity of employing the aid of any additional part of speech.

In English, however, the case is otherwise; for were we to say, "He rode Edinburgh, went the parliament-house, walked his counsel the court met," we should speak unintelligibly; as in these expressions there is either a total want of connexion, or such a connection as produce falsehood and nonsense. In order to give meaning to the passage, the several gaps must be filled up by words significant of the various relations by which the different ideas are connected in the mind; as, "He rode to Edinburgh, went to the parliament-house, and walked with his counsel till the court met." Of these connecting words, TO and WITH are called prepositions, AND and TILL are usually called conjunctions. Although these prepositions and conjunctions are not so absolutely necessary in Greek and Latin as they are in English; yet as there is no language wholly without them, nor any language in which it is not of importance to understand their force, they well deserve a place in universal grammar.

100. The sole use of conjunctions and prepositions in language is to connect either sentences or other words; but the theory of these connectives themselves has certainly never been understood, unless HORNE TOOKER has at last hit upon the truth. Mr HARRIS writes about them and about them, quoting passages from Greek and Latin authors, and produces at last no information. His definitions of both, as parts of speech void of signification, are highly absurd; and even the principal distinction which he makes between them seems not to be well founded. Prepositions and conjunctions denote the relations subsisting between the ideas expressed by those words or sentences which they serve to connect; and as relations are contemplated by the mind as well as positive ideas themselves, the words which denote those relations cannot be insignificant. The essential difference between the conjunction and preposition, according to the same author, consists in this, that the former connects sentences, and the latter words: but the fact is often otherwise. An obvious example occurs where the conjunction AND connects not sentences but words. "A man of WISDOM and VIRTUE is a perfect character." Here it is not meant to be asserted, "that the man of WISDOM is a perfect character, and that the man of VIRTUE is a perfect character:" both these assertions would be false. This sentence therefore (and many such will occur) is not resolvable into two; whence it follows, that the conjunction AND does not always connect sentences; and the same is frequently the case with other conjunctions.

Horne Tooker's idea of prepositions and conjunctions is, that they do not form distinct classes of words, but are merely abbreviations of nouns and verbs: and with respect to the English language, he has been remarkably successful in proving his position. But though such be undeniably the case in English, it would be rash to conclude a priori that it is so in all other tongues. To establish this general conclusion would require a long and tedious deduction in each particular language; and how much language, leisure, industry, and acuteness, such an undertaking would require, even in one tongue, it is not easy to determine. In the languages with which we are best acquainted, many conjunctions, and most prepositions, have the appearance at least of original words; and though this most acute grammarian, from his knowledge of the northern tongues, has been able to trace the most important of those in English to

Prepositions, &c.

113
Expressed by prepositions and conjunctions.

114
These connect either sentences or words.

Conjunctions.

very plausible sources, the same thing would be difficult in other languages of which the sources are obscure, and absolutely impossible in those of which they are wholly unknown. It is, however, a strong presumption in favour of his opinion, that grammarians have never been able to assign any *general characteristic* of those species of words; which, did they constitute *distinct parts of speech*, one would think could not have so long remained undiscovered. It is a farther presumption in his favour, that many words in Greek and Latin, as well as in English, which have been called *conjunctions*, are obviously resolvable upon his principles, and indeed discover their meaning and origin upon mere inspection. We shall therefore content ourselves with retailing the common doctrine respecting these parts of speech so far as it is intelligible; subjoining at the bottom of the page the analysis given by Horne Tooke of the most important *English conjunctions* and *prepositions*; and requesting our readers, who would understand the subject, to attend more to the relations between their various ideas, than to the frivolous distinctions which, in compliance with custom, we are compelled to lay before them. We shall treat first of the *conjunction*.

SECT. I. Of Conjunctions.

115 Definition of conjunction.

101. A conjunction is a part of speech of which, as its name indicates, the use is to connect either two or more words in a sentence, or to make of two simple sentences one compound sentence. It is usually said, that conjunctions never connect words, but sentences only, and that this is the circumstance which distinguishes them from *prepositions*. We have already given one example which proves this distinction to be ill founded; we shall now give from *Horne Tooke* one or two more, which will place its absurdity in a still clearer light: *Two AND two are four; John AND Jane are a handsome couple; AB and BC and CA form a triangle. Are two four? Is John a couple and Jane a couple? Does one straight line form a triangle?* From the subjoined note it appears, that AND (G) may connect any two things which can be connected, as it signifies *addition*.

116 Which are either conjunctive or disjunctive.

Conjunctions connecting sentences, sometimes connect their meaning, and sometimes not. For example, let us take these two sentences, *Rome was enslaved, Cæsar was ambitious*, and connect them together by the conjunction BECAUSE; *Rome was enslaved BECAUSE Cæsar was ambitious*. Here the meanings, as well as the sentences, appear to be connected by that natural relation which subsists between an effect and its cause; for the enslaving of Rome was the effect of Cæsar's ambition. That particular relation therefore is that which is

denoted by the conjunction BECAUSE (H), which would be improperly used to connect two sentences between which the relation of an effect to its cause exists not. But if it be said, *manners must be reformed, OR liberty will be lost*; here the conjunction OR, though it join the sentences, yet as to their meaning is a perfect disjunctive. Between the reformation of manners and the loss of liberty there is certainly a natural relation; but it is not the relation of contiguity or similitude, or of cause and effect, but of contrariety. The relation of contrariety therefore is the signification of the word OR (I). And thus it appears, that though all conjunctions may combine sentences, yet, with respect to the sense, some are CONJUNCTIVE and others DISJUNCTIVE.

Conjunctions.

102. Those conjunctions which conjoin both sentences and their meanings are either COPULATIVES or CONTINUATIVES. The principal copulative in English is AND, which we have already considered. The continuatives are much more numerous; IF, AN, BECAUSE, THEREFORE, WHEREFORE, HENCE, &c. The difference between them is this: The copulative does no more than barely couple words or sentences; and is therefore applicable to all subjects of which the natures are not incompatible (K). The relation which it denotes is that of juxtaposition, or of one thing added to another. Continuatives, on the contrary, by a more intimate connection, consolidate sentences into one continuous whole; and are therefore applicable only to subjects which have an essential relation to each other, such as that of an effect to its cause or of a cause to its effect. For example, it is no way improper to say, *Lysippus was a statuary, AND Priscian a grammarian; the sun shineth, AND the sky is clear*; because these are things that may coexist, and yet imply no absurdity. But it would be absurd to say, *Lysippus was a statuary BECAUSE Priscian was a grammarian*; though not to say, *the sun shineth BECAUSE the sky is clear*. With respect to the first, the reason is, that the word BECAUSE denotes the relation which an effect bears to its cause: but the skill of Priscian in grammar could not possibly be the cause of Lysippus's skill in statuary; the coincidence between the skill of the one and that of the other, in arts so very different, was merely accidental. With respect to the shining of the sun and the clearness of the sky, the case is widely different; for the clearness of the sky is the CAUSE of the sun's shining, at least so as to be seen by us.

117 Conjunctions either copulative or continuative.

As to the continuatives, they are either SUPPOSITIVE, such as *if, an*; or POSITIVE, such as *because, therefore, as*, &c. Take examples of each: *You will live happily IF you live honestly; you live happily BECAUSE you live honestly; you live honestly, THEREFORE you live happily*. The difference between these continuatives is this: The suppositives denote connection, but do not assert actual existence;

118 Continuatives, either suppositive or positive.

G 2

(G) AND is a Saxon word, being (according to Mr H. Tooke) an abbreviation of ANAD, the imperative of the verb ANANAD, to add to or heap up. So that when we say *two AND two are four*, we only declare that *two added to two are four*.

(H) BECAUSE is compounded of the Saxon BE—by, and cause; and by some of our most ancient authors it was written BY CAUSE. *Rome was enslaved BECAUSE Cæsar was ambitious*, is therefore equivalent to, *Rome was enslaved by the cause CÆSAR WAS AMBITIOUS*; taking the phrase, *Cæsar was ambitious* as an abstract noun in concord with the other noun *cause*.

(I) OR seems to be a mere contraction of the Saxon ODER, which signifies other, i. e. something different and often contrary. So that the conjunction or must always denote diversity, and very often contrariety.

(K) As *day and night, heat and cold*: for we cannot say of the same portion of time, *it is day AND it is night*; or of the same body, it is both *hot AND cold*.

Conjunctions.
118
Positives, either causal or collective.

istence; the *positives* imply both the *one* and the *other* (L).

The *positives* above mentioned are either CAUSAL; such as, *because, since, as* (M), &c.: Or COLLECTIVE; such

as, *therefore, wherefore, &c.* The difference between these is this: The *causals* subjoin *causes* to *effects*; as, *the sun is in eclipse, BECAUSE the moon intervenes*: The *collectives* subjoin *effects* to *causes*; as, *the moon intervenes, THEREFORE*

Conjunctions

(L) The reason of all this will be apparent from the analysis given by *Horne Tooke* of those words which we have called *suppositive* conjunctions. IF and AN may be used mutually and indifferently to supply each other's place; for they are both *verbs*, and of the same import. IF is merely the imperative of the *Gothic* and *Anglo-Saxon* verb GIFAN, *to give*; and in those languages, as well as in the English formerly, this *supposed conjunction* was pronounced and written as the common imperative GIF. Thus,

"My largesse

"Hath lotted her to be your brother's mistress,

"GIF shee can be reclaimed; GIF not, his prey."

Sad Shepherd, Act ii. scene 1.

Gawin Douglass almost always uses GIF for IF, as the common people in some counties of Scotland do even at this day; and it is obvious, that our IF has always the *signification* of the English imperative *give*, and no other. So that the resolution of the construction in the sentence, *If you live honestly you will live happily*, is simply this, *GIVE you live honestly* (taking *you live honestly* as an abstract noun) *you will live happily*. Your living *happily* is declared to depend upon your living *honestly* as the *condition*; but *give that*, and your happiness is positively asserted. In like manner may such sentences be resolved as,

"I wonder he can move! that he's not fixed!

"IF THAT his feelings be the same with mine."

Thus, "His feelings be the same with mine, *give that*, I wonder he can move," &c. And here we cannot forbear giving our assent to the truth of Mr Tooke's observation, that when the *datum* upon which any conclusion depends is a *sentence*, the article THAT, if not expressed, *may* always be inserted. We do not, however, think the *insertion* at all times absolutely *necessary* to complete the syntax; for active *verba* govern *whole sentences* and *clauses* of sentences as well as substantive *nouns*. Instances of this occur so frequently in the Latin classics, that they can have escaped no man's notice who has ever read *Horace* or *Virgil* with attention. We agree likewise with our most ingenious author, that where the *datum* is not a sentence, but some *noun* governed by the verb IF or GIVE, the article THAT can never be inserted. For example, if we be asked, how the weather will dispose of us to-morrow? we cannot say: IF THAT fair, it will send us abroad; IF THAT foul, it will keep us at home;" but "IF fair, it will send us abroad," &c. The reason is obvious: the verb in this case directly governs the noun; and the resolved construction is, "GIVE fair weather, it will send us abroad; GIVE foul weather, it will keep us at home."

AN, the other suppositive conjunction mentioned, is nothing else than the *imperative* of the Anglo-Saxon verb ANAN, which likewise means *to give* or *to grant*. As, "AN you had an eye behind you, you might see more detraction at your heels than fortune before you;" that is, "GRANT you had an eye behind you, you might see," &c. This account of the two *conditional conjunctions* in English is so rational and satisfactory, that we are strongly inclined to believe that all those words which are so called, are in all languages to be accounted for in the same manner. Not indeed that they must all mean precisely *to give* or *to grant*, but some word equivalent; such as, *be it, suppose, allow, permit, &c.*; which meaning is to be sought for in the particular etymology of each respective language.

(M) Of the *causal conjunctions* mentioned in the text, BECAUSE has been already considered; and some account must be given of the two words SINCE and AS. The former of these, according to Mr H. Tooke, is a very corrupt abbreviation, confounding together different words and different combinations of words. To us it appears to be compounded of SEAND, *seeing*; and ES, *that or it*; or of SIN, *seen*, and ES. SEAND and SIN are the *present* and *past* participles of the Anglo-Saxon verb SEON, *to see*. In modern English SINCE is used four ways; *two* as a *PREPOSITION* affecting *words*, and *two* as a *CONJUNCTION* affecting *sentences*. When used as a *preposition*, it has always the signification of the past participle SEEN joined to THENCE (i. e. *seen and thenceforward*), or else the signification of the past participle SEEN only. When used as a *conjunction*, it has sometimes the signification of the *present* participle SEEING, or SEEING THAT; and sometimes the signification of the past participle SEEN, or SEEN THAT. We shall give examples of all these significations. 1st. As a *preposition* signifying SEEN and thenceforward: "A more amiable sovereign than George III. has not swayed the English sceptre SINCE the conquest." That is, "The conquest seen (or at the completion of the sight of the conquest), and thenceforward, a more amiable sovereign than George III. has not swayed the English sceptre." SINCE, taken in this sense, seems rather to be a corruption of SITHTHAN or SITHENCE, than a compound of SEAND and ES. 2dly, As a *preposition* signifying SEEN simply: Did George III. reign before or SINCE that example? 3dly, As a *conjunction*, SINCE means *seeing that*: as, "If I should labour for any other satisfaction but that of my own mind, it would be an effect of phrenzy in me, not of hope; SINCE (or *seeing that*) it is not truth but opinion that can travel through the world without a passport." 4thly, It means SEEN THAT or THAT SEEN; as, "SINCE death in the end takes from all whatsoever fortune or force takes from any one, it were a foolish madness in the shipwreck of worldly things, when all sinks but the sorrow, to save that;" i. e.—Death in the end takes from all whatsoever fortune or force takes from any one; THAT SEEN, it were a foolish madness," &c.

As, the other *causal* conjunction mentioned in the text, is an *article* meaning always IT, or THAT, or WHICH. Take the following example:

"She glides away under the foamy seas

"As swift AS darts or feather'd arrows fly."

Conjunctions

THEREFORE (N) *the sun is in eclipse.* We therefore use *causals* in those instances where, the *effect* being conspicuous, we seek for its *cause*; and *collectives*, in demonstration and science, properly so called, where the *cause* being first known, by its help we discern *effects*.

119
Causal conjunctions denote four kinds of causes.

As to *causal* conjunctions, we may further observe, that there is no one of the four species of causes which they are not capable of denoting. For example, the *MATERIAL cause*; *The trumpet sounds BECAUSE it is made of metal.* The *FORMAL*; *The trumpet sounds BECAUSE it is long and hollow.* The *EFFICIENT*; *The trumpet sounds BECAUSE an artist blows it.* The *FINAL*; *The trumpet sounds THAT it may raise our courage.* It is worth observing, that the three first causes are expressed by the strongest affirmation; because if the *effect* actually be, these must be also. But this is not the case with respect to the last, which is only affirmed as a thing that *may* happen. The reason is obvious; for whatever may be the *end* which set the artist first to work, *that end* it may still be beyond his power to obtain; as, like all other contingents, it may either happen or not. Hence also it is connected by a particular conjunction, **THAT** (O), absolutely confined to this *cause*.

120
Disjunctive conjunctions.

103. We come now to the **DISJUNCTIVE CONJUNCTIONS**;

a species of words which bear this contradictory name, because while they *CONJOIN* the sentences, they *DISJOIN* the sense; or, to speak a language more intelligible, they denote *relations* of **DIVERSITY** or **OPPOSITION**.

Conjunctions

That there should be such words, whether called *conjunctions* or not, is extremely natural. For as there is a principle of **UNION** diffused through all things, by which **THIS WHOLE** is kept together and preserved from dissipation; so is there in like manner a principle of **DIVERSITY** diffused through all, the source of *distinction*, of *number*, and of *order*. Now it is to express in some degree the *modifications of this diversity*, that those words called **DISJUNCTIVE CONJUNCTIONS** are employed.

Of these *disjunctives* some are **SIMPLE** and some **ADVERSATIVE**: *Simple*; as when we say, *EITHER it is day or it is night: Adversative*; as when we say, *it is not day BUT it is night.* The difference between these is, that the *simple* express nothing more than a *relation of DIVERSITY*; the *adversative* express a *relation* not barely of *diversity*; but also of **OPPOSITION**. Add to this, that the *adversatives* are **DEFINITE**, the *simple* **INDEFINITE**. Thus when we say, *the number three is not an even number BUT (P) an odd*, we not only *disjoin* two opposite attributes, but we *definitely* affirm the *one* to *belong* to the

121
Either simple or adversative.

That is, "She glides away (with) **THAT** swiftness (with) **WHICH** darts or feathered arrows fly." In German, where **AS** still retains its original signification and use, it is written **ES**. So is another *conjunction* of the same import with **AS**, being evidently the Gothic article **SA** or **SO**, which signifies *it* or *that*.

(N) As Mr Harris has called **THEREFORE**, **WHEREFORE**, &c. *collective conjunctions*, we have retained the denomination, though perhaps a more proper might be found. It is indeed of little consequence by what name any class of words be called, provided the import of the words themselves be understood. **WHEREFORE** and **THEREFORE** evidently denote the *relation* of a *cause* to its *effects*. They are compounds of the Saxon words **HWÆR** and **THÆR** with **FOR** or **VOOR**: and signify, *for which*, *for those*, or *that*. It is worthy of remark, that in some parts of Scotland the common people even at this day use **THIS** for *these*.

(O) We have already considered the word **THAT**, and seen that it is never a conjunction, but uniformly a definite article. "The trumpet sounds (for) **THAT** it may raise our courage;" taking the clause *it may raise our courage* as an abstract noun in concord with *that* and governed by *for*. Or the sentence may be resolved thus: "The trumpet may raise our courage (for) **that** (purpose) it sounds."

(P) Mr Horne Tooke has favoured us with some ingenious remarks on the two different derivations of the word **BUT**, when used in the two acceptations that are usually annexed to it, viz. that which it bears in the *beginning* of a sentence, and that which it has in the *middle*. He has given it as his opinion, that this word, when employed in the *former way*, is corruptly put for **BOT**, the imperative of the Saxon verb **BOTAN**, *to boot*, *to superadd*, *to supply*, &c. and that when used in the *latter* it is a contraction of **BE-UTAN**, the imperative of **BEONUTAN**, *to be out*. Our ancient writers made the proper distinction between the orthography of the one word and that of the other. Gawin Douglass, in particular, although he frequently confounds the two words, and uses them improperly, does yet abound with many instances of their proper use; and so contrasted, as to awaken, says our author, the most inattentive reader. Of the many examples quoted by him, we shall content ourselves with the two following:

"BOT thy worke shall endure in laude and glorie,

"BUT spot or fault condigne eterne memorie."

Preface.

—"BOT gif the fates, BUZ pleid,

"At my pleasure suffer it me life to leid."

Book iv.

If this derivation of the word **BUT** from **BOTAN**, *to superadd*, be just, the sentence in the text, "the number, three is not an even number **BUT** an odd," will be equivalent to, "the number three is not an even number, superadd (it is) an odd number;" and if so, the opposition is not marked (at least directly) by the word **BUT**, but by the adjectives **EVEN** and **ODD**, which denote attributes in their own nature opposite. It is only when **BUT** has this sense that it answers to *sed* in Latin, or to *mais* in French. In the second line of the quotation from Gawin Douglass's Preface, the word **BUT** is evidently a contraction of **BE-UTAN**, and has a sense very different from that of **BOT** in the preceding line. The meaning of the couplet is, "**SUPERADD** (to something said or supposed to be said before) thy work shall endure in laude and glorie, **BE OUT** (i. e. *without*) spot or fault," &c. In the following passage from **DONNE**, the word **BUT**, although written in the same manner, is used in both its meanings: "You must answer, that she was brought very near the fire, and as good as thrown in; or else, that she was provoked to it by a divine inspiration. **BUT** that another divine inspiration moved the beholders to believe that she did therein a noble act, this act of her's might have been calumniated." That

Conjunctions. the *subject*, and *deny the other*. But when we say, *the number of the stars is EITHER (Q) even OR odd*; though we assert *one attribute to be*, and the other *not to be*, yet the alternative is notwithstanding left *indefinite*.

As to *adversative disjunctives*, it has been already said, after Mr Harris, that they imply *OPPOSITION*: but the truth seems to be, that they only unite in the same sentence *words or phrases* of opposite meanings. Now it is obvious, that *opposite attributes* cannot belong to the *same subject*; as when we say, *Nereus was beautiful*, we cannot *SUPERADD* to this sentence, that *he was ugly*; we cannot say, *he was beautiful BUT ugly*. When there is *opposition*, it must be either of the *same attribute in different subjects*; as when we say, "*Brutus was a patriot, BUT Caesar was not*:" Or of *different attributes in the same subject*; as when we say "*Gorgius was a sophist, BUT not a philosopher*." Or of *different attributes in different subjects*; as when we say, "*Plato was a philosopher, BUT Hippias was a sophist*." The conjunctions used for all these purposes have been called *absolute adversatives*, we think improperly, as the *opposition* is not marked by the *conjunctions*, but by the *words or sentences* which they serve to *connect*. Mr Locke, speaking of the word *BUT*, says, that "it sometimes intimates a *stop* of the mind, in the course it was going, before it came to the end of it;" to which Mr Tooke replies with truth, that *BUT* itself is the farthest of any word in the language from *intimating a stop*. On the contrary, it always intimates something to *follow*; inasmuch, that when any man in discourse finishes his words with *BUT*, instead of supposing him to have *stopped*, we always ask, *BUT what?*

Besides the *adversatives* already mentioned, there are two other species, of which the most important are UN-

LESS and *ALTHOUGH*. For example, "*Troy will be taken, UNLESS the palladium be preserved*; *Troy will be taken, ALTHOUGH Hector defend it*." The nature of these *adversatives* may be thus explained. As every *event* is naturally allied to its cause, and by parity of reason it is opposed to its *preventive*; and as every cause is either *adequate* or *inadequate* (inadequate when it endeavours without being effectual), so in like manner is every *preventive*. Now *adequate preventives* are expressed by such *adversatives* as *UNLESS*: "*Troy will be taken, UNLESS the palladium be preserved*;" that is, *this alone is sufficient to prevent it*. The *inadequate* are expressed by such *adversatives* as *ALTHOUGH*: "*Troy will be taken ALTHOUGH Hector defend it*;" that is, *Hector's defence will prove ineffectual*. These may be called *adversatives ADEQUATE and INADEQUATE*.

Such is the doctrine of Mr Harris; which although we can discover in it no determinate meaning, we have ventured with others to retail, in respect to our readers, who may be more perspicacious than ourselves. The author was a man of great learning; and the subject, as he has treated it, appears to be intricate. But whatever sense or nonsense there may be in what he says of *causes and preventives adequate and inadequate*, we have no hesitation to affirm that he has totally mistaken the import of the words *UNLESS* and *ALTHOUGH*. From these being called both *preventives*, the *one adequate* and the *other inadequate*, an unwary reader might be led to infer, that they denote the *same idea* or the *same relation*; and that the whole difference between them is, that the expression of the one is more forcible than that of the other. Nothing, however, can be farther than this from the truth. The meaning of *UNLESS* is directly opposite to that of *ALTHOUGH*. *UNLESS (R)* and *THOUGH* are

is, "You must answer, that she was brought very near the fire," &c. *Superadd* (to that answer) *BE OUT* (or *UNLESS* or *WITHOUT*; for, as will be seen by and bye, all those words are of the same import) that another divine inspiration moved," &c. To these remarks and examples it may be worth while to add, that even now *BUT* is often used by the illiterate Scotch for *WITHOUT*; as nothing is more common than to hear a clown say, "He came from home *BUT* his breakfast."

Having mentioned *WITHOUT* as a word of the same import with *BUT* when distinguished from *BOT*, it may not be improper to consider that word here; for though in modern English it is entirely confined to the office of a preposition, it was formerly used indifferently either as a *preposition* or a *conjunction*. *WITHOUT* then is nothing but the imperative *WYRTHAN-UTAN*, from the Anglo-Saxon and Gothic verb *WEORTHAN*, *WITHAN*; which in the Anglo-Saxon language is incorporated with the verb *BEON*, *esse*. According to this derivation, which is *Horne Tooke's*, the word *WITHOUT*, whether called conjunction or preposition, is the same as *BE OUT*; and such will be its import, should it after all be nothing more than a compound of *WITH*, which signifies to *join*, and sometimes to *be*, and *UTE*, *out*.

(Q) *EITHER* is nothing more than a distributive *pronoun*, which every body understands; and *OR* we have already explained.

(R) So low down as in the reign of Queen Elizabeth (says *Horne Tooke*) this conjunction was sometimes written *oneles* or *onelesse*; but more anciently it was written *ONLES* and sometimes *ONLESSE*. Thus, in the trial of Sir John Oldcastle in 1413, "It was not possible for them to make whole Christes cote without some, *ONLESSE* certeyn great men were brought out of the way." So, in "The image of governance," by Sir T. Eliot, 1451, "Men do fere to approuche unto their sovereigne Lord, *ONLES* they be called." So again, in "A necessary doctrine and erudition for any Christian man, set furthe by the king's majestic of England," 1543, "*ONLES* ye believe, ye shall not understande." "No man shall be crowned, *ONLES* be lawfully fight." "The soul waxeth feeble, *ONLESSE* the same be cherished." "It cannot begyane, *ONLESSE* by the grace of God." Now, *ONLES* is the imperative of the Anglo-Saxon verb *ONLESAN*, to *dismiss* or *remove*.

LES, the imperative of *LESAN* (which has the same meaning as *ONLESAN*), is likewise used sometimes by old writers instead of *UNLESS*. Instances might be given in abundance from *G. Douglass* and *Ben Johnson*; but perhaps it may be of more importance to remark, that it is this same imperative *LES*, which, placed at the end of nouns and coalescing with them, has given to our language such adjectives as *hopeless*, *restless*, *deathless*, *motionless*, &c. i. e. *dismiss hope*, *rest*, *death*, *motion*, &c.

Mr Tooke observes, that all the languages which have a conjunction corresponding to *LESS* or *UNLESS*, as

are both verbs in the *imperative mode*: the former signifying *take away* or *dismiss*: the latter *allow, permit, grant, yield, assent*. This being the case, "Troy will be taken UNLESS the *palladium* be preserved," is a sentence equivalent to "REMOVE the *palladium* be preserved (taking the *palladium* be preserved as an abstract noun, the preservation of the *palladium*) Troy will be taken." Again, "Troy will be taken, ALTHOUGH Hector defend it," is the same as "Troy will be taken ALLOW Hector (to) defend it." The idea, therefore, expressed by UNLESS is that of the REMOVAL of one thing to make way for another; the idea expressed by ALTHOUGH (S) is that of ALLOWING one thing to COEXIST with another, with which it is APPARENTLY incompatible.

104. Before we take leave of this subject, we might treat, as others have treated, of *adverbial* conjunctions, and conjunctions (T) of various other denominations. But of multiplying subdivisions there is no end; and systems, in which they abound, convey for the most part no information. The nature of conjunctions can be thoroughly understood only by tracing each to its original in some parent or cognate tongue; and when that shall be done in other languages with as much suc-

cess as it has lately been done by Mr *Horne Tooke* in English, then, and not till then, may we hope to see a rational, comprehensive, and consistent theory of this part of speech. Then too shall we get rid of all that farrago of useless distinctions into *conjunctive, adjunctive, disjunctive, subjunctive, copulative, continuative, subcontinuative, positive, suppositive, causal, collective, preventive, adequate and inadequate, adversative, conditional, illative, &c. &c.*; which explain nothing, and which serve only to veil ignorance and perplex sagacity.

Conjunctions. 123 Which serves only to veil ignorance.

That Mr *Tooke's* principles will apply exactly to the conjunctions of every language both dead and living, is what our limited knowledge of these languages does not authorise us positively to affirm. It is, however, a strong presumption in favour of his opinion, that illiterate savages, the first cultivators of language, are little likely to have sent out their faculties in quest of words to denote the *abstract relations* subsisting among their ideas, when we have such evidence as his book affords that the names of the most *common substances* and *qualities* could answer *that* and every other purpose, which in the ordinary intercourse of life can be answered by the faculty of speech. It is a farther presumption in his favour,

well as the manner in which the place of these words is supplied in the languages which have not a conjunction correspondent to them, strongly justify his derivation which we have adopted. The Greek *ουχι*, the Latin *nisi*, the Italian *se non*, the Spanish *sino*, the French *si non*, all mean *be it not*. And in the same manner do we sometimes supply its place in English by *but, without, be it not, but if, &c.* It may be proper just to add, that, according to the same author, the conjunction LEST is a contraction of LESED, the past participle of LESEN; and that LEST with the article *that*, either expressed or understood, means no more than *hoc dimisso* or *quo dimisso*.

(S) ALTHOUGH is compounded of *al* or *all*, and THO', THOUGH, THAT, or, as the vulgar more purely pronounce it, THAF, THAUF, and THOF. Now, THAF or THAUF, is evidently the imperative THAF or THAFIG of the verb THAFIAN or THAFIGAN to *allow, permit, grant, yield, assent*; and THAFIG becomes *thak, though, thoug*, (and *thoch*, as G. Douglass, and other Scotch authors write it) by a transition of the same sort, and at least as easy as that by which HAFUC becomes *hawk*. It is no small confirmation of this etymology, that anciently they often used *all be, albeit, all had, all were, all give*, instead of ALTHOUGH; and that as the Latin *SI (if)* means *be it*, and *NISI* and *SINE (unless and without)* mean *be not*, so *ETSI (although)* means *and be it*.

(T) In a work of this kind, which professes to treat of *universal* grammar, it would be impertinent to waste our own and our readers time on a minute analysis of each conjunction which may occur in any one particular language. We shall therefore pursue the subject no farther; but shall subjoin Mr HORNE TOOKE's table of the English conjunctions, referring those who are desirous of fuller satisfaction to his ingenious work entitled *The Diversions of Parley*.

IF	} Are the Imperatives	GIF	} Of their respective Verbs	GIF	To give.
AN		AN		ANAN	To grant.
UNLESS		ONLES		ONLESAN	To dismiss.
EKE		EAC		EAKAN	To add.
YET		GET		GETAN	To get.
STILL		STELL		STELLAN	To put.
ELSE		ALES		ALESAN	To diminish.
THOUGH		THAFIG		THAFIGAN	} To allow.
or		or		or	
THO'		THAF		THAFIAN	
BUT		BOT		BOTAN	To boot, or superadd.
BUT		BE-UTAN		BEON-UTAN	To be out.
WITHOUT		WYRTH-UTAN		WYRTHAN-UTAN	To be out.
AND	AN AD	ANAN AD	Dare congeriem.		
LEST is the participle LESED of LESEN, to dismiss.					
SINCE	} is the participle of SKON, to see.	SITHAN			
		SYNE			
		SEAND-ES			
		SITHTHE			
		or			
	SIN-ES				

THAT is the article or pronoun THAT. As is ES, a German article, meaning *it, that, or which*. And SO is SA or so, a Gothic article of the same import with AS.

Propositions. favour, that in the rudest languages there are few if any conjunctions; and that even in others which are the most highly polished, such as Greek and Latin, as well as English, many of those words which have been called conjunctions are obviously resolvable into other parts of speech. Thus *αλλὰ*, translated *but*, is evidently the neuter gender of either the *nominative* or *accusative plural* of *ἄλλος*; another; and when used as a conjunction, it intimates that you are going to add something to what you have already said. *Cæterum* has the same meaning, and is nothing but *καὶ ἕτερον*. *MAIS* (*but* in French) is the Latin *maius*; *ut, uti, ut, quod*, is the *relative pronoun*. Of *quocirca, quia, præterea, antequam, quenquam, quemvis, quantumvis, quamlibet*, &c. the resolution is too obvious to require being mentioned. Where such resolutions as these can be made, or when the conjunctions of any particular tongue can be traced to their origin in any other, there needs be no dispute about their *true import*; but when the case is otherwise, and the conjunction either appears to be an *original word*, or is derived from a *source* to which it cannot be traced, we would advise such of our readers as wish to speak or write correctly, to dismiss from their minds all considerations of *copulatives, continuatives, causals, and disjunctives*, with the rest of that jargon which we have already mentioned; and to inquire diligently in what manner and for what purpose the conjunction in question is used by the best writers, both ancient and modern, of the particular language which they are studying. This will indeed be found a work of labour; but it appears to us to be the only means left of discovering the precise relations which such conjunctions were intended to express; and, by consequence, of knowing what words or sentences they are fitted to connect, so as to produce a style at once accurate and perspicuous.

SECT. II. Of Propositions.

125 **Propositions unite two words that refuse to coalesce of themselves;**

105. By Mr Harris and his followers, a PROPOSITION is defined to be a part of speech ~~that~~ *itself of signification, but so formed as to unite two words that are significant, and that refuse to coalesce or unite of themselves.* We have already expressed our opinion of that theory which holds certain words to be devoid of signification; but its absurdity, in the present instance, is more than ever glaring. Concerning the number of propositions, it is well known that hitherto authors have never agreed. The ancient Greek grammarians admitted only 18; the ancient Latin grammarians above 50; though the moderns, *Sunctius, Sciopius, Perizonius, Vossius, and Ruddiman*, have endeavoured to lessen the number without fixing it. Bishop *Wilkins* thinks that 36 are sufficient; and *Girard* says that the French language has done the business effectually with 32. But if propositions be words devoid of signification, why should there be disputes respecting their numbers? or why in any language should there be more than one preposition, since a single unmeaning mark of connection would certainly answer the purpose as well as a thousand? The *cypher*, which has no value of itself, and only serves (if we may use the language of grammarians) to connote and consignify, and to change the value of figures, is not several and various, but uniformly one and the same. That "the preposition is so formed, as to unite two words which refuse to coalesce or unite of themselves," is indeed true; and this union it effects,

Propositions. not by having no signification of its own, but by signifying the relation by which the things expressed by the united words are connected in nature. Propositions are to be accounted for in much the same manner as the cases of nouns. The necessity of this species of words, or of some equivalent invention, follows from the possibility of having in language a distinct complex term for each distinct collection of ideas which we may have occasion to put together in discourse. The addition or subtraction of any one idea to or from a collection of ideas, makes it a different collection; and, if, after either of these operations, it were to be expressed by the same word as before, nothing could ensue but misrepresentation and falsehood. Now, to use in language a different and distinct complex term for each different and distinct collection of ideas, is equally impossible, as to use a distinct particular term for each particular and individual idea. To supply, therefore, the place of the complex terms which are wanting in a language, are the cases of nouns and prepositions employed; by the aid of which, complex and general terms are prevented from being infinite or too numerous, and are used only for those collections of ideas which we have most frequent occasion to mention in discourse. By means of propositions this end is obtained in the most simple manner. For, having occasion to mention a collection of ideas for which there is no single complex term in the language, we either take that complex term which includes the greatest number, though not all of the ideas we would communicate; or else we take that complex term which includes all and the fewest ideas more than those we would communicate; and then, by the help of the preposition, we either make up the deficiency in the one case, or retrench the superfluity in the other. For instance, having occasion to mention a house of a particular description, and knowing that the term *house* is too general for our purpose, and that the building we have in view has no appropriate name, we say, perhaps, a house WITH a party-wall, or a house WITHOUT a roof.—In the first instance, the complex term *house* is deficient, and the preposition directs to add what is wanting.—In the second instance, the complex term is redundant as it denotes a complete house; the preposition, therefore, directs to take away what is superfluous.

Now, considering propositions in this the most simple light, as serving only to limit or modify general terms, it is absolutely necessary that they should have meanings of their own; for otherwise, how could we, in the instance before us, make known by them our intention, whether of adding to, or retrenching from, the same general term *house*. If, to a disciple of Mr HARRIS, we should say, a house JOIN; he would reply, JOIN WHAT? But he would not contend that JOIN is an indeclinable word which has no meaning of its own, because he knows that it is the imperative of a verb, of which the other parts are still in use; and its own meaning is clear, though the sentence is not completed. If, instead of JOIN, we should say to him, a house WITH; he would still ask the same question, WITH what? But if we were to discourse with him concerning the word WITH, he would probably tell us, that WITH is a preposition, an indeclinable word, which is itself devoid of signification, but so formed as to unite two words that are significant. And yet it would be evident by his question, that he felt it had a meaning of its own; which

preposi-
tions.

is in reality the same as JOIN (U). Indeed, so far has always been plainly perceived, that WITH and WITHOUT are directly opposite and contradictory; and it would puzzle the most acute philosopher to discover opposition and contradiction in two words where neither of them had any signification. Wilkins, therefore, has well expressed their meaning, where he says, that WITH is a preposition "relating to the notion of *social*, or circumstance of *society* AFFIRMED; and that WITHOUT is a preposition relating to the same notion of *social*, or circumstance of *society* DENIED."

117
they all
serve to
modify in
different
ways some
general
term or
general af-
firmation.

106. But to denote the relations of *adding* and *taking away*, is not the only purpose for which prepositions are employed. They all indeed serve to modify some *general term* or *general affirmation*, but not precisely in the same way as WITH and WITHOUT. It has been already observed, that words significant of those things which coincide in nature, coalesce with one another in syntax, without being beholden to any auxiliary tie. For instance, an *adjective* coalesces with its *substantive*, a *verb* with its *nominative*; a noun expressing an *object* acted upon, with a *verb* denoting *action*; and an *adverb* with its *verb*. Take the following example: THE SPLENDID SUN GENIALLY WARMETH THE FERTILE EARTH. But suppose we were desirous to modify this affirmation by the addition of other substantives, AIR, for instance, and BEAMS: how would these coincide with the other words of the sentence, or under what character could

they be introduced? Not as *nominatives* or *accusatives* to the *verb*, for both these places are already filled: the *nominative* by the substance SUN, which is certainly the *agent* in this operation; the *accusative* by the substance EARTH, which is as certainly the object acted upon. Not as *qualities* of the SUN and EARTH: for qualities inhering in their substances can only be expressed by *adjectives*, and the words *air* and *beams* are both *substantives*. Here then we must have recourse to prepositions; but we can employ only such prepositions as point out the *relations* which the AIR and the BEAMS have to the *sun warming the earth*. In English we should say, *the splendid sun WITH his beams genially warmeth THROUGH the air the fertile earth*. The sentence, as before, remains *entire* and *one*; the *substantives* required are both *introduced*; and not a word which was there before is detruded from its proper place. The import of WITH we have already discovered; it directs to UNITE the *beams* to the *sun*, as JOINTLY with him performing the operation. But the AIR has no other connexion with this operation, than as the MEDIUM OF PASSAGE between the SUN and the EARTH: and therefore the preposition THROUGH (X) must denote that *relation* which subsists between an *object* in *motion*, and the *medium* in which it moves; nor could a preposition of a different import have been employed, without altering the meaning of the whole sentence (Y).

Preposi-
tions.

107. Mr Harris is of opinion that most, if not all, prepositions

(U) This account of prepositions is taken from *Horne Tooke*, who adds, that the only difference between the two words WITH and JOIN, is, that the other parts of the Gothic and Anglo-Saxon verb WITHAN, *to join* (of which WITH is the imperative), have ceased to be employed in the language. As WITH means *join*, so the correspondent French preposition AVEC means, *and have that, or, have that also*. But though WITH, as the imperative of WITHAN, means *join*, it has sometimes a very different signification. Mr *Tyrwhit* in his Glossary has truly observed, that WITH and BY are often synonymous. They certainly are so; but then WITH seems to be an abbreviation of the imperative of WYRTHAN, *to be*; as WITHOUT is of WYRTHAN-UTAN, *to be out*. This being the case, our two instances in the text will stand thus: *a house JOIN a party-wall; a house BE-OUT a roof*. Nor let any one be surprised that we make no difference between the *conjunction* WITHOUT and the preposition WITHOUT. The word is the same, whether it be employed to unite *words* or *sentences*. Prepositions were originally, and for a long time, classed with *conjunctions*; and when first separated from them, they were only distinguished by the name of *prepositive conjunctions*. They are generally used to unite *words*, but not always; for we may say indifferently, *I came after HIS DEPARTURE*, or *I came after HE DEPARTED*. By the greater part of grammarians, indeed, AFTER, when employed as in the first sentence, is classed with the prepositions; when employed as in the second, it is classed with the conjunctions. The word, however, is the same in both sentences; its *meaning* is the same, and its *effect* precisely the same. The only circumstance of discrimination is, that in the first example it is prefixed to a noun, *his departure*; in the second, it is prefixed to a nominative and a verb, *he departed*. But even the nominative and the verb, thus applied, express no more than a specifying circumstance annexed to the other proposition, *I came*; and whenever they are rightly apprehended by the mind, they are stript of their prepositional form, and considered *abstractly* under a new phasis, *his departure*. Thus, then, the two sentences are synonymous in every respect, excepting the *apparent* grammatical nature of the words *his departure*, and *he departed*; and even these are reduced to one grammatic form in the mind, whenever the import of the propositions is rightly apprehended. WITHOUT, and many other prepositions, especially in the learned languages, are used exactly as AFTER is used in the two instances which we have given. *Horne Tooke* quotes Lord Mansfield for saying, "It cannot be read WITHOUT the Attorney-General consents to it." This, in modern English, is not the common phraseology; but it offends not against any principle of grammar. The *nominative* and the *verb* are here, as in the former instance, considered as an *abstract noun*. "It cannot be read WITHOUT the consent of the Attorney-General."

(X) THOROUGH, THOROUGH, THOROW, THROUGH, or THRO', is no other, says *Horne Tooke*, than the Gothic substantive DAURO, or the Teutonic substantive THURUH, and, like them, means *door, gate, passage*. So that the sentence in the text, resolved upon his principles, stands thus: "The splendid sun—JOIN his beams—genially warmeth—PASSAGE the air, (or, the air being the *passage* or *medium*)—the fertile earth." And in the same manner may we translate the preposition *through* in every instance where *through* is used in English, or its equivalent preposition in any language; as from the Latin and Italian word *porta* (in Spanish *puerta* and in French *porte*), have come the Latin and Italian preposition *per*, the French *par*, and the Spanish *por*.

(Y) If, for instance, we were to substitute WITH or OF instead of THROUGH, we should in the one case alter the

Prepositions.
125
Prepositions originally denoted the various relations of body,

prepositions were originally formed to denote the relations of PLACE. For this opinion we see not sufficient evidence. If indeed we could suppose the inventors or earliest improvers of language to have at all concerned themselves with relations as abstracted from the objects related, we must believe that those which first attracted their attention were the relations subsisting among themselves, and the various bodies with which they were surrounded. We must likewise agree with our author, that place is the grand relation which bodies or natural substances maintain at all times to one another; but we do not therefore think that it would attract the earliest notice of untaught barbarians. On the contrary, we are of opinion that mankind must have made very considerable progress in science before they attempted to abstract place from body; an attempt which, according to some of the most profound philosophers (Z), is not only difficult, but absolutely impracticable. But whatever be in this, the relations of cause and effect, of duration and motion, are in themselves as obvious, and as likely to arrest the attention and obtain names, as those of place.—Among men totally illiterate they are evidently more so; for pain and pleasure would suggest some idea of cause and effect as matters of importance. There is, however, no probability that the inventors of any language had the least idea of abstract relations. They doubtless expressed complex conceptions by nouns and verbs, significant at once of the particular ideas and of the various relations by which they viewed those ideas as combined together in a complex conception. Afterwards, when mens minds became enlarged, and when, from the fluctuation inseparable from a living language, objects or ideas received new names, the old words, whether nouns or verbs, which were originally employed to express a par-

ticular complex conception, of which certain particular RELATIONS made a part, might be retained for the purpose of denoting those and all similar RELATIONS; and thus verbs and nouns would degenerate into particles bearing the names of prepositions and conjunctions. For instance, one Anglo-Saxon being desirous to communicate to another his own conception of a house with a party-wall, and having (we shall suppose) no such word in his tongue as a preposition, would naturally utter the word house, desiring his friend, at the same time, to add to that well known sound another sound (uttering it) significant of the particular circumstance wanting to complete his complex conception;—A house WITH (i. e. JOIN) a party-wall. The word WITH, as the imperative of a verb, denotes of course three ideas combined together, viz. a command or wish, an affirmation, and the idea of junction. But when the verb WITHAN was dismissed from the English language, the imperative WITH was still retained; but losing its verbal and modal nature, it was thenceforth employed to denote only one of the three ideas for which it originally stood, viz. the idea of junction. And thus it is, that verbs, and also nouns and adjectives, in passing from one language to another, may become prepositions (A) and conjunctions. Thus too it is, that some of those prepositions come to denote the contiguous, and some the detached, relation of body. The contiguous, as when we say, Caius walked WITH a staff; i. e. Caius JOIN a staff, walked; the statue stood UPON (B) a pedestal, i. e. the statue stood (the place of its standing) the HIGHER PART of a pedestal; the river ran OVER a sand, i. e. the river ran (the place of its running) the HIGHER PART of a sand. The detached relation, as when we say, He is going TO (C) Italy, i. e. He is going, THE

Prepositions.

129
and were at first either verbs or nouns.

END

meaning, and in the other speak nonsense. "The sun warmeth WITH the air the fertile earth," is an affirmation that the sun warmeth BOTH THE AIR AND THE EARTH; whereas the original sentence affirmed nothing more than that he warmeth the EARTH. "The sun warmeth OF the air the fertile earth," is nonsense, as it makes the earth a part, or a consequence, of the air. So necessary is it that prepositions have a meaning, and that the meaning of each be attended to.

(Z) The Bishops BERKELEY and LAW, with the very learned and ingenious Principal CAMPBELL of Aberdeen. See *The Principles of Human Knowledge*, LAW's *Notes on KING's Origin of Evil*, and *The Philosophy of Rhetoric*.

(A) As the Italian substantive CASA, a house, race, family, nation, &c. in passing to the French, becomes the preposition CHEZ, to which there is not, so far as we know, a preposition of precisely the same import in any language. SENZA or SENZE, in Italian, becomes SANS in French, and means absence. Nor is it necessary that verbs and nouns should always pass from one language to another, in order to be converted into prepositions. The Greek preposition χωρις is evidently the corrupted imperative of χωρίζω, to sever, to disjoin, to separate. The Latin SINE is SIT NE, be not. The German SONDER is the imperative of SONDERN, which has the same meaning as χωρίζω.

(B) UP, UPON, OVER, BOVE, ABOVE, have all, says *Horne Tooke*, one common origin and signification. In the Anglo-Saxon, UFA, UFERA, UFEMEST, are the adjectives ALTUS, ALTIOR, ALTISSIMUS. UFA or UFAN, up; comparative UFERA, OFERE or OFER, over or upper; superlative UFEMEST, utmost or uppermost. BEUFAN, BUFAN, ON BUFAN, bove, above. If this be a just account of the origin of these words, the sentences in the text, where upon, over, and above, occur, will run thus: "The statue stood ON HIGH a pedestal;" "the river ran HIGHER a sand;" "the sun is risen ON HIGH the hills." And here we may observe, that the mere relation between standing, running, &c. and place, is rather inferred from the verb itself, than expressed by a separate word; and the reason is obvious. For if a statue stand, every one knows that it must stand on some thing as well as at some time. There is therefore no necessity, whatever elegance there may be in it, for employing any word to denote that relation, which is commonly believed to be signified by on; but it is necessary to insert, between the verb and pedestal, a word significant of place, that pedestal may not be mistaken, by an ignorant person, for a portion of time, or any thing else connected with the standing of the statue.

(C) That TO is significant of detached relation, is the language of Mr Harris, which, though it may be allowed in a loose and vulgar sense, is certainly not philosophically just. The preposition TO (in Dutch written TOE and TOT) is the Gothic substantive TAUI or TAHTS, signifying act, effect, result, or consumption; which Gothic substantive is itself no other than the past participle TAUID or TAUIDS of the verb TAUIAN agere. And

Prepositions.

Prepositions.

END (of his journey) *Italy*; the sun is risen ABOVE the hills, i. e. the sun is risen (the place) THE TOP of the hills: these figs came FROM Turkey, i. e. these figs came BEGINNING (their journey at) Turkey.

Besides the detached relation of body, Mr Harris is of opinion that the preposition FROM denotes two other relations not less different than those of motion and rest. Thus if we say, "That lamp hangs FROM the ceiling, the preposition FROM assumes a character of quiescence.

But if we say, *That lamp is falling FROM the ceiling*, the preposition in such case assumes a character of motion." But this is evidently a mistake: the detached relation in the former instance of the figs, as well as the motion and rest in the present instances, are expressed not by the preposition, but by the verbs *came, falls, hangs*. The word *from* has as clear, as precise, and at all times as uniform and unequivocal a meaning, as any word in the language. FROM means merely BEGINNING, and nothing

it is obvious, that what is done, is terminated, ended, finished. In the Teutonic, this verb is written TUAN or TUON; whence the modern German THUN, and its preposition TU. In the Anglo-Saxon, the verb is TEOGAN, and the preposition TO. DO, the auxiliary verb, as it has been called, is derived from the same root, and is indeed the same word as TO. The difference between a T and a D is so very small, that an etymologist knows by the practice of languages, and an anatomist by the reason of that practice, that in the derivation of words it is scarce worth regarding. To support this etymon of TO, Mr Horne Tooke gives a similar instance in the Latin tongue. The preposition AD, he says, is merely the past participle of AGERE, which past participle is likewise employed as a Latin substantive. He exhibits the derivation of AD thus:

Agitum—agtum	{	AGDUM—AGD—AD
		or or or
		ACTUM—ACT—AT

The most superficial reader of Latin verse (he observes), knows how readily the Romans dropped their final *um*. And a little consideration of the organs and practice of speech will convince him how easily AGD or ACT would become AD or AT; as indeed this preposition was indifferently written either way by the ancients. By the later writers of Rome, the preposition was written AD with D only, in order to distinguish it from the other corrupt word called the conjunction AT; which for the same reason was written with the T only, though that likewise had anciently been written, as the preposition, either AD or AT. The preposition TO and the conjunction TOO in English, are both in syntax and in meaning used exactly as the preposition AD and the conjunction AT in Latin. From the specimens prefixed to Johnson's dictionary, as a history of our language, it appears that, as late as the reign of Elizabeth, the preposition and conjunction were both written with one O. And it has been shown in the first volume of the Transactions of the Royal Society of Edinburgh, that TO and TOO, as well as AD and AT, are precisely of the same import. The only difference, in either language, between the preposition and the conjunction, is, that the former directs, as a modification of some previous proposition, the addition of some substantive or noun; the latter, sometimes a sentence or clause of a sentence considered abstractly as a noun; and that, when the former is used, the preposition, to which the modifying circumstance is to be added, is formally expressed, but omitted when the latter is employed. Thus Denham says,

"Wisdom he has, and, TO his wisdom courage;
"Temper TO that, and, UNTO all, success."

In this example, every succeeding circumstance is by the preposition TO marked as an addition to the preceding. "Wisdom he has, and courage additional to his wisdom." But Denham might with equal propriety have omitted the object which TO governs, or to which it directs something to be added, though he must then, from the custom of the language, have employed the conjunction instead of the preposition. As,

"Wisdom he has, and courage too," &c.

This mode of expression would have been more concise, and as intelligible as the other, "Wisdom he has, and courage TO his wisdom," &c.

Not only is the object governed by TO omitted, when it is represented by a substantive in the context, but also when it is involved in a preposition; and then the conjunction, as it is called, is always used. Thus,

"_____ Let those eyes that view
"The daring crime, behold the vengeance TOO."

So, "He made him prisoner, and killed him too." In the one example, the circumstance of beholding the vengeance is stated as an addition to the viewing of the crime; and in the other, the killing him is stated as an addition to the making him a prisoner. In both examples, the object governed by TOO is the amount of the preceding proposition taken abstractly as a noun or substantive. Thus then it appears, that TO and TOO, though classed the one with the prepositions, and the other with the conjunctions, are really one and the same word. The same is true of AD and AT. Thus, "AD hoc, promissa barba et capilli efferaverant speciem oris," signifies "Additional to this, his long beard and hair had given a wildness to his aspect." But when the object governed by AD is not formally stated, AD itself is classed with the conjunctions, and written differently, AT. Thus TERENCE, "PH. Fac ita ut jussi, deducantur isti. PA. Faciam. PH. AT diligenter. PA. Fiet. PH. AT maturè." By the means of AT, the circumstances of diligence and haste are superadded to the action commanded. "PH. It is not enough that you do it, you must do it carefully TOO." PA. Well, it shall be carefully done. "PH. In good time TOO." AT, taken in this sense, is most commonly employed, like the English BUT, to mark the unexpected union of incongruous objects: As, "Aulam tyranni frequentabat, AT patriam amabat;" literally, "He frequented the court of the tyrant; joined EVEN TO that he loved his country." "He was a courtier and a patriot TOO." But if AD and AT in Latin, and TO and TOO in English, be derived from verbs which signify to DO or ACT, it may be asked how they come themselves to denote addition. The answer is obvious.

Prepositions.

thing else. It is simply the *Anglo-Saxon* and *Gothic* noun *FRUM*, *beginning, origin, source, fountain, author* (D). Now if this meaning be applied to Mr *Harris's* instances, *FROM* will speak clearly for itself, without the assistance of the *interpreting* verbs, which are supposed by him to *vary its character*.

"These figs *came FROM* Turkey."

"That lamp *falls FROM* the ceiling."

"That lamp *hangs FROM* the ceiling."

Came is a complex term for one species of motion; *falls* is a complex term for another species of motion; and *hangs* is a complex (E) term for a species of attachment. Have we occasion to communicate or mention the COMMENCEMENT or BEGINNING of these motions, and of this attachment, and also the *place where* they commence or begin? To have complex terms for each occasion of this sort is absolutely impossible; and therefore nothing can be more natural or more simple than to add the signs of those ideas, viz. the word BEGINNING (which will remain always the same) and the NAME of the *place* (which will perpetually vary). Thus,

"These figs *came—BEGINNING* Turkey."

"That lamp *falls—BEGINNING* ceiling."

"That lamp *hangs—BEGINNING* ceiling."

That is,

"Turkey the *place* of BEGINNING to come."

"Ceiling the *place* of BEGINNING to fall."

"Ceiling the *place* of BEGINNING to hang."

It has been said by no less a man than Bishop Wilkins, that *FROM* refers *primarily to place, and secondarily to time*. But the truth is, that *FROM* relates to every thing to which *beginning* relates, and to nothing else.

"*FROM* morn till night the eternal larum rang."

That is, "The larum rang BEGINNING morning (or morning being the *time* of its BEGINNING) till night."

As *FROM* always denotes *beginning*, so *TO* and *TILL* always denote the *end*. There is, however, this difference between them, that *TO* denotes the *end of any thing*; *TILL* the *end only of time*. We may say indifferently—"From morn to night," or "from morn TILL night, the eternal larum rang;" but we cannot say—"These figs came from Turkey TILL England."

Prepositions.

That *TILL* can, with propriety, be opposed to *FROM* only when we are talking of *time*, is evident; for it is a word compounded of *TO* and *WHILE*, i. e. *time*. And as the coalescence of these two words *TO-WHILE*, took place in the language long before the present superfluous use of the article *THE*, the phrase—"From morn TILL night" is neither more nor less than—from *From morn TO TIME* night. When we say, "*from morn TO night*," the word *TIME* is omitted as unnecessary.

Besides *FROM*, Mr *Harris* mentions *OVER* as significant sometimes of *motion* and sometimes of *rest*; and quotes as instances the two following passages from *Milton*;

—To support uneasy steps

OVER the burning marl.

Here, says he, *OVER* denotes *motion*. Again,

—He with looks of cordial love

Hung OVER her enamoured.

Here *OVER* denotes *rest*. But the truth is, that *OVER* denotes neither *motion* nor *rest* in either of the passages. In the first quotation, indeed, *MOTION* is implied; but it is implied in the word *STEPS*; and not in *OVER*, which denotes only that the *place* of the steps was the *top* of the burning marl. In the second quotation *rest* is implied, and *that* too a particular species of rest; but it is implied or rather expressed by the verb *HUNG*, and *OVER* denotes the *place* of that species of rest.

108. But though the original use of prepositions was to denote *the relations of body*, they could not be confined to this office only. They by degrees extended themselves to subjects *incorporeal*; and came to denote relations, as well *intellectual* as *local*. Thus, because in place he who is *above* has commonly the advantage over him who is *below*; hence we transfer *OVER* and *UNDER* (F) to *dominion* and *obedience*. Of a king, we say, *he ruled OVER his people*; of a soldier, *he served UNDER his general*. So too we say, *with thought*; *without* attention; *thinking over* a subject; *under* anxiety; *from* fear; *through* jealousy, &c. All which instances, with many others of like kind, show, that the first words of men, like their *first ideas*, had an immediate reference to *sensible objects*; and that in after days, when they began to discern with their *intellect*, they took those words which they

130
They were by degrees extended to subjects incorporeal.

If a man should utter a sentence, and to the end of it subjoin the very general word *DO*, the person to whom he spoke, would naturally ask, *DO what?* and this question would, of course, produce an *additional* sentence or clause of a sentence. Besides, it is to be observed, that *AGERE*, from which the Latin preposition is derived, as well as the Gothic verb, which is the source of the English particles, means not only *TO DO*, but also to *adduce* or *bring*; so that when we say, he is going *TO* Italy," we do nothing more than *affirm* that "he is *going*," and desire the person to whom we speak, "to *ADD* Italy, to the journey."

From this derivation of the preposition *TO*, it will be seen at once upon what principle it is employed to mark the infinitive mode. In the learned languages that mode is generally known by its termination; but in English it would be impossible, without the aid of *TO* or of some other word significant of *action*, to distinguish the *VERB* love from the *noun* or *substantive*.

(D) This derivation is Mr *Horne Tooke's*; and he supports it by the following sentence: *NE RÆDD GE SE THE ON FRUMMAN WORHTE, HE WORHTE WÆPMAN AND WIFMEN*; which is the *Anglo-Saxon* of St *Matt.* xix. 4. "Annon legistis, quod qui eos *in principio* creavit, creavit eos marem et feminam?"

(E) These are *complex* terms because they are *verbs*. Each denotes an *affirmation* and *time*; and combined with these, *came* and *falls* denote *motion*, and *hangs* denotes *rest*.

(F) *UNDER* and *BENEATH*, though by the sound they seem to have little connection, are yet in fact almost the same word, and may very well supply each other's place. *UNDER* is nothing but *ON-NEDER*, and *BENEATH* is compounded of the imperative *BE* and the noun *NEATH*. *NEATH* uncompounded having slipped away from our language, would perhaps be unintelligible, had not the *nouns* *NETHER* and *NETHERMOST* still continued in common use. *NEATH*; *Anglo-Saxon*, *NEOTHAN*, *NEOTHE*; *Dutch*, *NEDEN*; *Danish*, *NED*; *German*, *NIEDRE*; and *Swedish*, *NEDRE* and *NEDER*; is undoubtedly as much a *substantive*, and has the same meaning, as the word *NADIR*. In common language it denotes the *bottom*.

Prepositions.

they found *already made*, and transferred them by metaphor to *intellectual* conceptions.

Among the relations which may be considered rather as intellectual than corporeal, are those of *cause* and *consequence*; and for the denoting of these we have *two prepositions*, which sometimes appear in direct opposition to one another, and at other times may exchange places without injury to the sense.

“Well! 'tis e'en so! I have got the London disease they call love. I am sick of my husband, and FOR my gallant.”
Wycherley's Country Wife.

Here OF and FOR seem almost placed in opposition; at least their effects in the sentence appear to be very different; for, by the help of these two prepositions alone, and without the assistance of any other words, she expresses the two contrary affections of *loathing* and *desire*. The truth, however, is, that the author, if it had pleased him, might have used OF where he has employed FOR, and FOR where he has put OF. This is evident from the following quotation:

“Marian. *Come, Amie, you'll go with us.*”

“Amie. *I am not well.*”

“Lionel. *She's sick of the young shepherd that bekist her.*”
Sad Shepherd.

In the same manner we may, with equal propriety, say—“We are sick of hunger;” or—“We are sick FOR hunger.” And in both cases we shall have expressed precisely the same thing, with only this difference, that, in the former sentence, we declare *sickness* to be a CONSEQUENCE; in the latter, we declare *hunger* to be a CAUSE. But to return to the *country wife*; that poor lady seems to have had a complication of distempers; she had, at least, two disorders—a *sickness or loathing*, and a *sickness of love*. She was sick FOR disgust, and sick FOR love. She was

Sick of disgust FOR her husband;

Sick OF love FOR her gallant.

Sick FOR disgust OF her husband.

Sick FOR love OF her gallant.

In the first sentence, as thus stated, *sickness* is declared to be the CONSEQUENCE of *disgust*, of which *her husband* is declared to be THE CAUSE. In the second, *sickness* is declared to be the CONSEQUENCE of love, of which *her gallant* is declared to be the CAUSE. In the third sentence DISGUST is declared to be the CAUSE of her *sickness*, and the CONSEQUENCE or OFFSPRING of her *husband*. In the fourth, *love* is declared to be the CAUSE of her *sickness*, and the CONSEQUENCE or OFFSPRING of her *gallant*.

Thus, then, it appears, that though the *two first* of these sentences, taken entire, convey the very same meaning with the *two last*, yet the import of the preposition FOR is as different from that of OF, as CAUSE is from CONSEQUENCE (G). When two words or sentences are linked together by the former of these prepositions, the object expressed by the last word or sentence is declared to be the CAUSE of that which is expressed by the preceding; when two words or sentences are linked together

by the latter preposition, the object expressed by the first word or sentence is declared to be the CONSEQUENCE OF, or to PROCEED FROM, the object expressed by the second. It is therefore a matter of perfect indifference to the sense, whether we say *sickness or hunger*, or *sickness FOR hunger*; *The man, or he speaks little, is wise, or the man is wise, FOR he speaks little*. By means of the preposition OF, we declare *sickness* to be the CONSEQUENCE proceeding from *hunger*, and *wisdom* to be the CONSEQUENCE we infer from the *man's speaking little*; by means of FOR, we declare *hunger* to be the CAUSE of *sickness*, and the circumstance of *speaking little* to be the CAUSE from which we infer the *man's wisdom*. In the one sentence, OF is to be considered as a noun in opposition to *sickness*; in the other, as a noun in opposition to *the man is wise taken abstractly as a noun*. In the one sentence FOR (i. e. CAUSE) is to be considered as a noun in opposition to *hunger*; in the other, as the same noun in opposition to *he speaks little taken abstractly as a noun*.

109. In the foregoing use of prepositions, we have seen how they are applied by way of *justa-position*; that is to say, where they are prefixed to a word without becoming a part of it. But they are used also by other way of composition; that is, they are prefixed to other words so as to become real parts of them. Thus in Greek we have *επιδακται*; in Latin *intelligere*; and in English *UNDERstand*. So also, to *FOREtel*, or *OVERact*, to *UNDERvalue*, to *OUTgo*, &c.; and in Greek and Latin other instances innumerable. In this case the prepositions commonly transfuse something of their own meaning into the word with which they are compounded. For example, if we suppose some given space, E and EX transfuse signify *out of* that space; PER, *through it*; IN, *within it*; SUBunder it. Hence E and PER, in composition, augment: *Enormis* is something not simply big, but big in excess; something got out of the rule, and beyond the measure. Dico, “to speak;” *edico*, “to speak out;” whence *edictum* “an edict,” something so effectually spoken as all are supposed to hear and all to obey.—On the contrary, IN and SUB diminish and lessen. *Injustus*, *iniquus*, “unjust, inequitable;” something that lies within justice and equity, that reaches not so far, that falls short of them. *Subniger*, “blackish;” *subrubicundus*, “reddish;” tending to black, and tending to red; but yet under the standard, and below perfection.

110. Before we dismiss this part of our subject, we shall make the same general remark on prepositions that we formerly made on conjunctions; viz. that the precise import of each can with certainty be known only by tracing it to its source in some word of known and determinate meaning either in the language where the preposition itself has place, or in some parent or cognate tongue. And it may be laid down as an infallible rule, that where different languages use the same or a similar particle, that language ought to be considered as its legitimate parent, in which the true meaning of the word can be found, and where its use is as common and familiar as that of any other verbs and substantives.

(G) *Iunius* derives FOR from the Greek *προς*; *Skinner*, from the Latin *pro*; but I believe, says *Horne Took*, that it is no other than the Gothic substantive FAIRINA, “cause.” He imagines also that OF (in the Gothic and Anglo-Saxon AF) is a fragment of the Gothic and Anglo-Saxon words AFARA and AFORA, *posteritas*, *proles*, &c. In a word, he considers FOR and OF as nouns or substantives; the former always meaning *cause*, the latter always meaning *consequence*, *offspring*, *successor*, *follower*, &c. If this account of these words be just, and we have no doubt of it, the prepositions FOR and OF are in syntax to be considered as nouns in opposition with other nouns, or with sentences taken abstractly as nouns.

Interjections.

stantives. When prepositions can be traced to such sources as these, no room can be left for disputes concerning their meaning. In carrying on this etymological pursuit, we find advantages in the nature of *prepositions* which *conjunctions* do not afford us. WITH and WITHOUT, FROM and TO, with many other words belonging to this class, have meanings directly opposite and contradictory to each other. If, then, by the total or partial extinction of an original language, the root of any one preposition be lost, whilst that of its opposite remains, the philosopher ought to be satisfied with reasoning from *contrariety*; as nothing is more evident, than that the meaning of a word is known when we know with precision the meaning of its opposite. When we meet, however, with a luckless preposition of which no root is left to be dug up, and which has itself no direct opposite in the language, nothing remains but that we inquire for what purpose it is used by the best writers both ancient and modern; and if we can fix upon *one meaning* which will apply, however awkwardly, to all the places where it occurs, or to the greater part of them, the probability is, that we have discovered the *true and original* (H) meaning of the preposition; and by keeping that meaning constantly in view, we shall ourselves be enabled to use the word with perspicuity and precision.

SECT. III. Of Interjections.

134
The interjection not properly any part of speech.

III. Besides the above parts of speech, there is another acknowledged in all the languages of Europe, called the INTERJECTION; a word which cannot be comprehended under any of the foregoing classes. The *genuine interjections* are very few in number, and of very little importance, as they are thrown into a sentence without altering its *form* either in *syntax* or in *signification*. In the words of *Horne Tooke* the brutish *inarticulate* interjection has nothing to do with speech, and is only the miserable refuge of the speechless. The dominion of speech, according to the same author, is erected on the downfall of *interjections*. Without the artful contrivances of languages, mankind would have nothing but *interjections* with which to communicate orally any of their feelings. "The neighing of a horse, the lowing of a cow, the barking of a dog, the purring of a cat, sneezing, coughing, groaning, shrieking, and every other involuntary convulsion with oral sound, have almost as good a title to be called parts of speech as *interjections*. In the intercourse of language, *interjections* are employed only when the suddenness or vehemence of some affection or passion returns men to their natural state, and makes them for a moment forget the use of speech; or when, from some circumstance, the shortness of speech will not permit them to exercise it." The genuine interjection, which is always expressive of some very strong sensation, such, as AH! when we feel pain, does not owe its characteristi-

cal expression to the arbitrary form of articulation, but derives its whole force from the tone of voice and modification of countenance and gesture. Of consequence, these tones and gestures express the same meaning, without any relation to the articulation which they may assume; and are therefore universally understood by all mankind. *Voluntary interjections* are used in books only for embellishment, and to mark forcibly a strong emotion. But where speech can be employed, they are totally useless; and are always insufficient for the purpose of communicating thought. Dr Beattie ranks *strange, prodigious, amazing, wonderful, O dear, dear me, &c.* when used alone, and without apparent grammatical syntax, among the *interjections*: but he might with as much propriety have considered *hardly, truly, really*, and even many Latin *verbs*, as *interjections*; for these two are often used *alone*, to supply the place of *whole sentences*. The truth is, that all men, when suddenly and violently agitated, have a strong tendency to shorten their discourse by employing a *single word* to express a *sentiment*. In such cases, the word employed, whether *noun, adjective, or verb*, would be the *principal* word of the sentence, if that sentence were completed; and the *agitation* of the speaker is such, and the *cause* of it so obvious, that the hearer is in no danger of mistaking the *sense*, and can himself supply the words that are wanting. Thus if a person, after listening to a romantic narrative, were to exclaim, *strange!* would any man of common sense suppose, that the word *strange*, because uttered alone, had lost the power of an *adjective* and become an *interjection*? No, surely: Every one sees, that the exclamation is equivalent to, *That is STRANGE, or That is a STRANGE story*. *Real interjections* are never employed to convey *truth* of any kind. They are not to be found amongst *laws*, in books of *civil institutions*, in *history*, or in any treatise of useful *arts or sciences*; but in *rhetoric and poetry*, in *novels, plays, and romances*, where in English, so far from giving *pathos* to the style, they have generally an effect that is disgusting or ridiculous.

HAVING now analysed *every part* of speech which can be necessary for the *communication of thought*, or which is acknowledged in any language with which we are acquainted; we shall dismiss the article of *Grammar*, after annexing a Table, which may present at one view the several *classes and subdivisions of words*. Of the different modes of dividing the parts of speech, as well as of the little importance of *systematic classifications*, we have already declared our decided opinion: but for the sake of those who may think differently from us, we shall in the annexed Table adopt Mr *Harris's* classification as far as it is intelligible; after informing our readers that Mr *Horne Tooke* admits only *three parts* of speech, the *article*, the *noun*, and the *verb*, and considers all other words as corruptions or abbreviations of the two last of these.

A

(n) For instance, let us suppose that *Horne Tooke's* derivation of FOR, from the Gothic substantive FAIRINA, is fanciful and ill-founded; yet there can be little doubt but CAUSE is its true and original meaning, when it is found, that of sixteen examples brought by *Greenwood*, and forty-six by *Johnson*, of different significations of the word FOR, there is not one where the *noun* CAUSE may not be substituted instead of the *preposition* FOR; sometimes indeed awkwardly enough, but always *without injury* to the *sense*. Even where FOR seems to be *loco adterius*, which *Lowth* asserts to be its *primary sense*, it will be found to be CAUSE, and nothing else: Thus *He made considerable progress in the study of the law before he quitted that profession FOR this of poetry*; i. e. *before he quitted that profession, this of poetry being the CAUSE of his quitting it*.

Gramma-
rian
Granada.

GRAMMARIAN, one that is skilled in or teaches grammar.

Anciently the name *grammarius* was a title of honour, literature, and erudition, being given to persons accounted learned in any art or faculty whatever. But it is otherwise now, being frequently used as a term of reproach, to signify a dry plodding person, employed about words and phrases, but inattentive to the true beauties of expression and delicacy of sentiment. The ancient grammarians, called also *philologers*, must not be confounded with the grammatists, whose sole business was to teach children the first elements of language. Varro, Cicero, Messala, and even Julius Cæsar, thought it no dishonour to be ranked grammarians, who had many privileges granted to them by the Roman emperors.

GRAMMONT, a town of France, in Upper Vienne, remarkable for its abbey, which is the chief of the order. E. Long. 1. 30. N. Lat. 46. 1.

GRAMPIAN HILLS; a chain of high mountains in Scotland, which run from east to west almost the whole breadth of the kingdom. See (*Scottish*) ALPS and SCOTLAND.—They take their name from only a single hill, the *Mons Grampius* of Tacitus, where Galgacus waited the approach of Agricola, and where the battle was fought so fatal to the brave Caledonians.

GRAMPOUND, a town of Cornwall in England, seated on the river Valle, over which there is here a bridge. W. Long. 4. 45. N. Lat. 50. 18. The inhabitants have a considerable manufacture of gloves; and the town sends two members to parliament. Some think that this town is the Veluba of the ancients, because it stands on the same river; and that on the building of the bridge, the name was changed into Grandpont. It was made a borough in the reign of Edward III. by whose charter it was endowed with large privileges, particularly freedom from toll through all Cornwall, a market on Saturday, and three fairs in the year; which the burghesses hold of the duchy of Cornwall in fee-farm, at the rent of about 12 guineas. Its privileges were confirmed by King Henry VIII. but it did not send members to parliament till the reign of Edward VI. It is a corporation with a mayor, eight magistrates, a recorder, and town-clerk. The mayor is chosen annually the Tuesday before Michaelmas, and the members by the majority of the magistrates and freemen, who are such of the inhabitants as pay scot and lot. It sends two members to parliament, who are chosen by as more than thirty voters. Population 601 in 1811.

GRAMPUS, a species of delphinus. See DELPHINUS, CETOLOGY *Index*.

GRANADA, a province of Spain, which for a long time was a kingdom distinct from the rest of that country. See the article SPAIN.—It made a part of the ancient Bætica; and was inhabited by the Bætulæ, the Sexitani, &c. At present it is sometimes called Upper Andalusia. It is bounded to the south and east by the Mediterranean, to the west and north by Lower Andalusia, and the north-east by Murcia. Its extent from west to east is two hundred and ten miles; but its greatest breadth exceeds not eighty. The air here is temperate and healthy; and though there are many mountains in the province, and some

of them very high, yet they are almost everywhere covered with vines and fruit-trees, together with laurel, myrtle, sweet-basil, thyme, lavender, marjoram, and other aromatic herbs, which give an exquisite taste to the flesh of their sheep and cattle. A great deal of silk and sugar, flax and hemp, honey and wax, is also produced here; besides dates and acorns, superior to the finest nuts; good stone for building; several sorts of gems; sumach, used in dressing goat-skins; and galls, of which a dye is made for leather. The valleys, with which the mountains are interspersed, are extremely beautiful and fertile. The inhabitants of some of the highest mountains are said to be descendants of the Moors; and, though they are become Roman Catholics, retain in a great measure, their ancient customs, manners, and language. The principal rivers in the province are the Genil or Xenil, and Guadalatin, besides which there are many lesser streams. Abundance of salt is made in this province. The present population is estimated at 700,000. Malaga is its principal port. It was the last of the kingdoms possessed by the Moors, and was not reduced and annexed to the crown of Castile until 1492.

GRANADA, the capital of the above province, is situated at the foot of the Sierra Nevada, or the Snowy Mountain, in a wholesome air and fruitful country, an hundred and eighty-eight miles south of Madrid, in W. Long. 3. 40. N. Lat. 37. 17. It stands upon two hills separated by the Darro. The Genil runs under the walls, and these two rivers are formed from the melting of the snow with which the mountain is constantly covered. The Darro is said to carry with it small particles of gold; and its name, derived from *lat aurum*, may be alleged as a proof of this: the Genil, in like manner, rolls with its stream little pieces of silver. When Charles V. came to Granada in 1526, with the empress Isabella, the city presented him with a crown made of gold gathered from the Darro. The city is large and magnificent, containing a great number of very handsome public and private buildings. Its walls, which are adorned with many towers at equal distances, are said to be ten miles in compass. Here are two castles; the one built by the Moors, and the other by Charles V. and Philip II. They both command a very fine prospect; and the first is so large, that it looks like a city by itself, and, it is said, has room enough to accommodate forty thousand people, exclusive of the royal palace, and the convent of St Francis. Here is also a court of inquisition; a royal tribunal; and an university, founded in 1531; with the see of an archbishop, who has a revenue of forty thousand ducats per annum. A great many noblemen, clergymen, and wealthy citizens, reside in this city, of which the silk trade and manufacture is considerable, and the arsenal is said to be the best furnished of any in Spain. The inhabitants, who are partly descended of the Moors, amounted to 66,000 in 1797. There are several fine squares, particularly that called the *Bivaramba*, or *Plaza Mayor*, where the bull-fights are held; and without the city is a large plain, full of towns and villages, called *La Vega de Granada*.

The Moors are said to regret nothing but Granada, amongst all the losses they have sustained in Spain; they mention it in all their evening prayers, and supplicate

heaven

Granada. heaven to restore it to their possession. The last Moorish ambassador who came into Spain obtained permission of the king to see Granada; he shed tears on entering the Alhambra, and could not refrain from exclaiming, that the folly of his ancestors had deprived them and their posterity of that delightful country.

Granada had formerly twenty gates: the first, that of Elvira, which still remains; the second, that of Bib-almazar, or of conference, because, with the Moors, it was a kind of place of resort where they conversed on affairs; the third, Vivarambla, so called from its leading to a grand square which still bears the same name; the fourth, Bib Racha, or of provisions; the fifth, Bitautabin, or the gate of the hermits, which led to different solitudes, the abodes of dervises; the sixth, Bib-mitre, or Biblacha, the first gate; the seventh, the mill gate; the eighth, that of the sun, because it opened to the east; the ninth, the gate of the Alhambra, called by the Moors Bib Luxar; the tenth, Bib Adam, or the gate of the bones of Adam; the twelfth, Bib Ciedra, the gate of the nobles; the Moors kept this gate shut for a long time, because it had been predicted that the enemies which should one day take the city, would enter by that gate; the thirteenth, is that of Faxalauza, or of the hill of almond trees; the fourteenth, the lion gate, in Arabic, Bib Elecei; the fifteenth, the coast gate, called by the Moors Alacabar; the sixteenth, Bib Albonut, or the gate of the Banners, at present the magdalen gate; the seventeenth, that of the Darro; the eighteenth, that of the Mosayca; the nineteenth, that called the gate of *Ecce Homo*; the twentieth, that by the side of the Alhambra.

The Moors have left more monuments in Granada than in any other city in Spain. From the great number of inscriptions in and about the city, and the fine edifices of the Alhambra and the Generalif, it might be supposed these people intended to make Granada the greatest depository of their religion, manners, customs, and magnificence. There is not a wall which does not bear some marks of their power; but, notwithstanding this abundance of monuments, the reign of the Moors in Spain is still buried in confusion and obscurity. The ignorance of the Spaniards, their superstition, and the hatred they bore the Moors, have much contributed to this darkness; they have either destroyed, or suffered to be effaced by time, every thing which bore the mark of Mahometanism, instead of preserving the monuments of antiquity, which at the same time were those of their own glory; and it may be said, that chance alone, and the solidity of their construction, much more than curiosity or a love of the arts, has preserved those which still exist, though daily going to ruin.

An account of the ALHAMBRA has been already given under its name in the order of the alphabet. From the hall of *Comares* there mentioned, there is a modern little staircase; the old one, which corresponded to the beauty of the edifice, having been destroyed. At the top of the staircase is a gallery, a part of which is inclosed with an iron railing: this kind of cage is called the prison of the queen. It was here the wife of the last king of Granada was imprisoned. The Gomels and Legris, two families of distinction, bore false witness against her virtue, and occasioned the destruction of the greatest part of the Abencerrages, another

powerful and numerous family of Granada of whom Granada. they were jealous. The history of this event is given as follows:

In the year 1491, Abdali, surnamed the Little, still reigned in Granada; but this city was upon the brink of ruin, for the principal families were divided against each other. The Moors had carried their arms against Jaen, and had been bravely repulsed. Abdali was consoling himself in one of his pleasure houses for the ill success of his enterprise, when the Zegrís, who long had been the secret enemies of the Abencerrages, took the opportunity of this defeat to represent them to the king as rebellious subjects, who employed their immense riches to gain the favour of the people and dethrone their sovereign. They accused Albin Hamet, the most rich and powerful among them, of having an adulterous commerce with the queen, and produced witnesses who asserted they had on a certain festival seen, at Generalif, under a bower of rose trees, Albin Hamet in the arms of that princess. The fury of Abdali may easily be imagined; he swore the destruction of the Abencerrages. But the Zegrís, too prudent to let his anger break forth, advised him to dissimulate, and not to suffer it to be known to that numerous and powerful family that he was informed of their perfidy. It will be better, said they, to entice them into the snare, and, before they can unite and put themselves into a state of defence, revenge upon their heads the insult offered to the crown. This advice was followed; Abdali went to the Alhambra, having ordered thirty of his guards to arm themselves, and the executioner to attend. The Abencerrages were sent for one by one, and beheaded as soon as they entered the hall of the lions, where there is still a large vase of alabaster, which was quickly filled with blood and the heads of expiring bodies. Thirty-five heads had already been struck off, and all the Abencerrages would have died in the same manner, had not a page, who had followed his master, and remained unperceived in the hurry of the execution, taken an opportunity of withdrawing and giving information to the rest of the unhappy family of what had passed. These immediately assembled their friends in arms, crying out through the city of Granada, "Treason! treason! Let the king die! he unjustly puts to death the Abencerrages!" The people, with whom they were favourites, did not hesitate in assisting them: fourteen thousand men were soon found in arms, and immediately proceeded towards the Alhambra, shouting all the way, Let the king die! Abdali, surprised his secret should have been so soon discovered, and severely repenting of having followed the pernicious counsels he had received, ordered the castle gates to be shut; but they were presently set on fire. Muley Hacén, who had been forced to abdicate the throne in favour of his son, hearing the tumult of the people, had one gate opened, and presented himself to appease the rage of the citizens; but he no sooner appeared, than he was lifted up by the multitude nearest the gate, who cried out, "Behold our king, we will have no other, long live Muley Hacén;" and leaving him surrounded by a strong guard, the Abencerrages, and other nobles, entered the castle, accompanied by upwards of an hundred soldiers. But they found the queen only, with her women, and in the utmost consternation at the sudden

Granada. sudden revolution, of which she knew not the cause. They asked for the king; and being informed he was in the hall of the lions, entered it furiously, and found him defended by the Zegris and the Gomels, and in less than two hours killed upwards of two hundred of them. Abdali had the good fortune to escape. The bodies of the beheaded Abencerrages were laid upon black cloth, and carried to the city. Muza, brother to Abdali, and who by his great actions had gained the favour of the people, seeing the Abencerrages were revenged, found means to appease them; and having learned that the king had taken refuge in a mosque near the mountain now called Saint Helena, went and brought him back to the castle of the Alhambra. For several days nothing but sighs and groans were heard throughout the city. Abdali shut himself up in the castle, and refused to see the queen. Those who had accused her of adultery, however, persisted in their false accusation, and said, they would maintain, with arms in their hands, against all who should contradict them, that the queen was guilty. The unhappy princess was imprisoned, and the day arriving on which she was to perish by the hands of the executioner, when none among the Moors offering to defend her, she was advised to commit her cause to some Christian knights, who presented themselves at the time appointed, and conquered her false accusers, so that she was immediately set at liberty. The taking of Granada soon followed this combat; Muza and the Abencerrages having, it is said, facilitated the conquest of it by Ferdinand and Isabella.

From the Alhambra you enter the Generalif by a low gate, which favoured the escape of Abdali when Ferdinand took Granada. Generalif is said to signify, in Arabic, the house of love, of dance, and pleasure. It was built by a prince of the name of Omar, who was so fond of music, that he retired to this palace, entirely to give himself up to that amusement. The Generalif is the most pleasing situation in the environs of Granada. It is built upon a very high mountain, whence waters rush from every side, which escape in torrents, and fall in beautiful cascades in the courts, gardens, and halls of that ancient palace. The gardens form an amphitheatre, and are full of trees, venerable from their antiquity. Two cypresses in particular are noted, called the Cypresses of the Queen, because it was near them the perfidious Gomel impeached the virtue of that princess and the honour of the Abencerrages. Of this place, travellers observe, that the writers of romances have never imagined a scene equal to it.

Granada was formerly called *Illiberia*, and founded, if we will believe some writers, by Liberia, a great-grand-daughter of Hercules, daughter of Hispan, and wife to Hesperus, a Grecian prince, and brother to Atalanta. Others, who support their assertions by proofs to the full as satisfactory, maintain that it was founded by Iberus, grandson of Tubal, and that it took the name of Granada, or Garnata, from Nata the daughter of Liberia; this word being composed of *Gar* (which in the language of the time signified grotto) and *Nata*; that is, "the grotto of Nata," because that princess studied astrology and natural history, and delighted in the country. It is certain that such a person as Nata, or Natayda, existed in the first ages of

VOL. X. Part I.

the foundation of Granada; and that in the place where the Alhambra now stands, there was a temple dedicated to Nativala. The date of the foundation of Granada is said to be 2808 years before Christ. We know that in the time of the Romans it was a municipal colony.—A description in Latin of Granada, such as it was in 1560, written by a merchant of Antwerp, named George Hosnabel, who travelled into Spain, is to be found in the work intitled *Civitates orbis terrarum*, printed at Cologne in 1576. This book also contains a good plan of the city of Granada.

GRANADA, or *Grenada*, one of the Caribbee islands. See **GRENADA**.

GRANADA, a town of Mexico, in America, in the province of Nicaragua, and in the audience of Guatemala, seated on the lake Nicaragua, 70 miles from the South sea. It was taken twice by the French buccaniers, and pillaged. The inhabitants carry on a great trade by means of the lake, which communicates with the North sea. W. Long. 87. 46. N. Lat. 10. 12.

GRANADA, New, a province of South America, in Terra Firma, about 950 miles in length, and 240 in breadth. It is bounded on the north by Carthagenia and St Martha, on the east by Venezuela, on the south by Popayan, and on the west by Darien. It contains mines of gold, copper, and iron; horses, mules, good pastures, corn, and fruits. It belongs to the Spaniards, and Santa-Fe de Bagota is the capital town. See **GRANADA, New**, SUPPLEMENT.

GRANADILLOES, the name of some islands of the Caribbees, in America, having St Vincent to the north and Granada to the south. They are so inconsiderable that they are quite neglected; but were ceded to England by the treaty of peace in 1763.

GRANADIER, a soldier armed with a sword, a firelock, a bayonet, and a pouch full of hand grenades. They wear high caps, are generally the tallest and briskest fellows, and are always the first upon all attacks.

Every battalion of foot has generally a company of granadiers belonging to it; or else four or five granadiers belong to each company of the battalion, which, on occasion, are drawn out, and form a company of themselves. These always take the right of the battalion.

GRANADO, or **GRENADÉ**, in the art of war, a hollow ball or shell of iron or other metal, of about 2½ inches diameter, which being filled with fine powder, is set on fire by means of a small fuse driven into the fuse-hole, made of well-seasoned beech-wood, and thrown by the granadiers into those places where the men stand thick, particularly into the trenches and other lodgments made by the enemy. As soon as the composition within the fuse gets to the powder in the granado, it bursts into many pieces, greatly to the damage of all who happen to be in its way. Granadoes were invented about the year 1594. The author of the Military Dictionary has the following remark on the use of granadoes. "Grenades have unaccountably sunk into disuse; but I am persuaded there is nothing more proper than to have grenades to throw among the enemy who have jumped into the ditch. During the siege of Cassel under the count de la Lippe, in the campaign of 1762, a young engineer

I

undertook

Granado
||
Granary.

undertook to carry one of the outworks with a much smaller detachment than one which had been repulsed, and succeeded with ease from the use of grenades; which is a proof that they should not be neglected, either in the attack or defence of posts."—The word Granado takes its rise from hence, that the shell is filled with grains of powder, as a pomegranate is with kernels.

GRANARD, a borough, market, fair, and post town in the county of Longford, province of Leinster; it gives title of earl to the family of Forbes; situated 52 miles from Dublin, and about 16 north-east of Longford. N. Lat. 53. 44. W. Long. 7. 30. Here is a remarkable hill or mount, called the *Mount of Granard*, thought to be artificial, and the site of a Danish castle or fort; which commands from its summit a most extensive prospect into six or seven adjoining counties. In this town have lately been given annual prizes to the best performers on the Irish harp. Granard has a barrack for a company of foot; and formerly returned two members to the Irish parliament; patronage in the families of Macartney and Greville. Fairs held 3d May and 1st October. This place takes its name from *Grian-ard*, or "the height of the sun," and was formerly the residence of the chiefs of North Teffia. It is sometimes written Orehard.

GRANARY, a building to lay or store corn in, especially that designed to be kept a considerable time.

Sir Henry Wotton advises to make it look towards the north, because that quarter is the coolest and most temperate. Mr Worlidge observes, that the best granaries are built of brick, with quarters of timber wrought in the inside, to which the boards may be nailed, with which the inside of the granary must be lined so close to the bricks, that there may not be any room left for vermin to shelter themselves. There may be many stories one above another, which should be near the one to the other; because the shallower the corn lies, it is the better, and more easily turned.

The two great cautions to be observed in the erecting of granaries are, to make them sufficiently strong, and to expose them to the most drying winds. The ordering of the corn in many parts of England, particularly in Kent, is thus: To separate it from dust and other impurities after it is thrashed, they toss it with shovels from one end to the other of a long and large room; the lighter substances fall down in the middle of the room, and the corn only is carried from side to side or end to end of it. After this they screen the corn, and then bringing it into the granaries, it is spread about half a foot thick, and turned from time to time about twice in a week; once a week they also repeat the screening it. This sort of management they continue about two months, and after that they lay it a foot thick for two months more; and in this time they turn it once a week, or twice if the season be damp, and now and then screen it again. After about five or six months they raise it to two feet thickness in the heaps, and then they turn it once or twice in a month, and screen it now and then. After a year, they lay it two and a half or three feet deep, and turn it once in three weeks or a month, and screen it proportionably. When it has lain two years or more, they turn it once in two months, and screen it once a quarter; and how long soever it is kept, the oftener the turn-

ing and screening are repeated, the better the grain will be found to be.—It is proper to leave an area of a yard wide on every side of the heap of corn, and other empty spaces, into which they turn and toss the corn as often as they find occasion. In Kent they make two square holes at each end of the floor, and one round in the middle, by means of which they throw the corn out of the upper into the lower rooms, and so up again, to turn and air it the better. Their screens are made with two partitions, to separate the dust from the corn, which falls into a bag, and when sufficiently full this is thrown away, the pure and good corn remaining behind. Corn has by these means been kept in our granaries 30 years; and it is observed, that the longer it is kept the more flour it yields in proportion to the corn, and the purer and whiter the bread is, the superfluous humidity only evaporating in the keeping. At Zurich in Switzerland, they keep corn 80 years, or longer, by the same sort of methods.

The public granaries at Dantzick are seven, eight, or nine stories high, having a funnel in the midst of each floor to let down the corn from one to another. They are built so securely, that though every way surrounded with water, the corn contracts no damp, and the vessels have the convenience of coming up to the walls to be loaded. The Russians preserve their corn in subterranean granaries of the figure of a sugar-loaf, wide below and narrow at top; the sides are well plastered, and the top covered with stones. They are very careful to have the corn well dried before it is laid into these storehouses, and often dry it by means of ovens; the summer dry weather being too short to effect it sufficiently.—Dantzick is the grand storehouse or repository of all the fruitful kingdom of Poland. The wheat, barley, and rye, of a great part of the country, are there laid up in parcels of 20, 30, or 60 lasts in a chamber, according to the size of the room; and this they keep turning every day or two, to keep it sweet and fit for shipping. A thunder storm has sometimes been of very terrible consequences to these stores. All the corn of the growth of former years has been found so much altered by one night's thunder, that though over night it was dry, fit for shipping or keeping, and proper for uses of any sort, yet in the morning it was found clammy and sticking. In this case, there is no remedy but the turning of all such corn two or three times a day for two months or longer; in which time it will sometimes come to itself, though sometimes not. This effect of thunder and lightning is only observed to take place in such corn as is not a year old, or has not sweated thoroughly in the straw before it was thrashed out. The latter inconvenience is easily prevented by a timely cure; but as to the former, all that can be done is carefully to examine all stores of the last year's corn after every thunder storm, that if any of this have been so affected, it may be cured in time; for a neglect of turning will certainly utterly destroy it.

According to Vitruvius's rules, a granary should always be at the top of a house, and have its openings only to the north or east, that the corn may not be exposed to the damp winds from the south and west, which are very destructive to it; whereas the contrary ones are very necessary and wholesome to it, serving

Granary.

Granary. to cool and dry it from all external humidity, from whatever cause. There must also be openings in the roof to be set open in dry weather, partly to let in fresh air, and partly to let out the warm effluvia which are often emitted by the corn. The covering of the roofs should always be of tiles, because in the worst seasons, when the other openings cannot be safe, there will always be a considerable inlet for fresh air, and a way out for the vapours by their joinings, which are never close. If there happen to be any windows to the south, great care must be taken to shut them up in moist weather, and in the time of the hot southern winds. There must never be a cellar, or any other damp place under a granary, nor should it ever be built over stables; for in either of these cases the corn will certainly suffer by the vapours, and be made damp, in one, and ill-tasted in the other.

M. du Hamel and Dr Hales recommend various contrivances for ventilating or blowing fresh air through corn laid up in granaries or ships, in order to preserve it sweet and dry, and to prevent its being devoured by weevils or other insects. This may be done by nailing wooden bars or laths on the floor of the granary about an inch distant from each other, when they are covered with hair-cloth only; or at the distance of two or three inches, when coarse wire-work, or basket-work of osier, is laid under the hair-cloth, or when an iron plate full of holes is laid upon them. These laths may be laid across other laths, nailed at the distance of 15 inches, and two or more deep, that there may be a free passage for the air under them. The under laths must come about six inches short of the wall of the granary at one end of them; on which end a board is to be set edgewise, and sloping against the wall: by this disposition a large air-pipe is formed, which having an open communication with all the interstices between and under the bars, will admit the passage of air below forcibly through a hole at the extremity of it, into all the corn in the granary, that will consequently carry off the moist exhalations of the corn. The ventilators for supplying fresh air may be fixed against the wall, on the inside or outside of the granary, or under the floor, or in the ceiling; but wherever they are fixed, the handle of the lever that works them must be out of the granary, otherwise the person who works them would be in danger of suffocation, when the corn is fumed with burning brimstone, as is sometimes done for destroying weevils. Small moveable ventilators will answer the purpose for ventilating corn in large bins in granaries, and may be easily moved from one bin to another. If the granary or corn ship be very long, the main air-pipe may pass lengthwise along the middle of it, and convey air, on both sides, under the corn. In large granaries, large double ventilators laid on each other, may be fixed at the middle and near the top of the granary, that they may be worked by a wind-mill fixed on the roof of the building, or by a water-mill. The air is to be conveyed from the ventilators through a large trunk or trunks, reaching down through the several floors to the bottom of the granary, with branching trunks to each floor, by means of which the air may be made to pass into a large trunk along the adjoining cross walls: from these trunks several lesser trunks, about four inches wide, are to branch off, at the distance of three or

four feet from each other, which are to reach through the whole length of the granary, and their farther ends are to be closed: seams of $\frac{1}{2}$ or $\frac{1}{4}$ of an inch are to be left open at the four joinings of the boards, where they are nailed together, that the air may pass through them into the corn. In some of these lesser trunks there may be sliding shutters, in order to stop the passage of the air through those trunks which are not covered with corn; or to ventilate one part of the granary more briskly than others, as there may be occasion. There must also be wooden shutters, hung on hinges at their upper part, so as to shut close of themselves; these must be fixed to the openings in the walls of the granary on their outside: by these means they will readily open to give a free passage for the ventilating air, which ascends through the corn, to pass off, but will instantly shut when the ventilation ceases, and thereby prevent any dampness of the external air from entering: to prevent this, the ventilation should be made only in the middle of dry days, unless the corn, when first put in, is cold and damp.

In lesser granaries, where the ventilators must be worked by hand, if these granaries stand on staddles, so as to have their lowest floor at some distance from the ground, the ventilators may be fixed under the lowest floor, between the staddles, so as to be worked by men standing on the ground, without or within the granary. A very commodious and cheap ventilator may be made for small granaries, by making a ventilator of the door of the granary; which may be easily done by making a circular screen, of the size of a quarter of a circle, behind the door: but in order to this, the door must be open, not inwards but outwards of the granary, so that as it falls back, it may be worked to and fro in the screen; which must be exactly adapted to it in all parts of the circular side of the screen, as well as at the top and bottom. But there must be a stop at about eight or ten inches distance from the wall, to prevent the door's falling back farther; that there may be room for a valve in the screen to supply it with air; which air will be driven in by the door, through a hole made in the wall near the floor, into the main air-trunk, in which there must be another valve over the hole in the wall, to prevent the return of the air.

To destroy weevils and other insects with which GRANARIES are apt to be infested.—The preservation of grain from the ravages of insects may be best effected by timely and frequent screening, and ventilation; as little or no inconvenience will follow corn or malt lodged dry, but what evidently results from a neglect of these precautions. For, whether the obvious damage arise from the weevil, the moth, or the beetle, that damage has ceased at the time the vermin make their appearance under either of these species, they being, when in this last state of existence, only propagators of their respective kinds of vermiculi; which, while they continue in that form, do the mischief.

In this last, or insect state, they eat little, their principal business being to deposit their ova (eggs), which unerring instinct prompts them to do where large collections of grain furnish food for their successors while in a vermicular state. It is therefore the business of industry, to prevent future generations of these ravagers, by destroying the eggs previous to their hatching; and

Granary
||
Grand.

this is best accomplished by frequent screening, and exposure to draughts of wind or fresh air. By frequently stirring the grain, the cohesion of their ova is broken, and the nidus of those minute worms is destroyed, which on hatching collect together, and spin or weave numerous nests of a cob-web like substance for their security. To these nests they attach, by an affinity of small threads, many grains of corn together, first for their protection, and then for their food. When their habitations are broken and separated by the screen, they fall through its small interstices, and may be easily removed from the granary with the dust. Those that escape an early screening will be destroyed by subsequent ones, while the grain is but little injured; and the corn will acquire thereby a superior purity. But by inattention to this, and sometimes by receiving grain already infected into the granary, these vermin, particularly the weevil, will in a short time spread themselves in that state everywhere upon its surface, and darken even the walls by their number. Under such circumstances, a hen or hens, with new hatched chickens, if turned on the heap, will traverse, without feeding (or very sparingly so) on the corn, wherever they spread; and are seemingly insatiable in the pursuit of these insects. When the numbers are reduced within reach, a hen will fly up against the walls, and brush them down with her wings, while her chickens seize them with the greatest avidity. This being repeated as often as they want food, the whole species will in a day or two be destroyed. Of the phalæna (moth), and the small beetle, they seem equally voracious: on which account they may be deemed the most useful instruments in nature for eradicating these noxious and destructive vermin. See *VERMIN, Destruction of*.

GRANATE, or GARNET, a species of mineral belonging to the siliceous genus. See *MINERALOGY Index*.

GRANATE-Paste. See *GARNET*.

GRAND, a term rather French than English, though used on many occasions in our language. It has the same import with *great*, being formed of the Latin *grandis*. In this sense we say, the grand-master of an order, the grand-master of Malta, of the freemasons, &c. So also the grand-signior, the grand-visir, &c. grand-father, grand-mother, &c.

Among the French there were formerly several officers thus denominated, which we frequently retain in English; as grand almoner, grand ecuyer, grand chambellan, grand voyer, &c.

GRAND-Assize. See *ASSISE*.

GRAND Distress (districtio magna), in *English Law*, a writ of distress, so called on account of its extent, which reaches to all the goods and chattels of the party within the county. The writ lies in two cases: either when the tenant or defendant is attached and appears not, but makes default; or where the tenant or defendant hath once appeared, and after makes default. On such occasions, this writ lies by common law, in lieu of a petit cape.

GRAND Gusto, among painters, a term used to express that there is something in the picture very great and extraordinary, calculated to surprise, please, and instruct.—Where this is found, they say, the painter was a man of *grand gusto*; and they use the words *sub-*

lime and *marvellous*, when they speak of a picture, in much the same sense.

GRAND Jury, larcency, serjeanty, &c. See *JURY*, &c.

GRANDEE, is understood of a lord of the first rank or prime quality.

In Spain, the term *grandees* is used absolutely to denote the prime lords of the court, to whom the king has once given leave to be covered in his presence: there are some grandees for life only; made by the king's saying simply, Be covered. Others are grandees by descent; made by the king's saying, Be covered for thyself and heirs. These last are reputed far above the former.

There are some who have three or four grandeeships in their family.

GRANDEUR and SUBLIMITY. These terms have a double signification: they commonly signify the qualification or circumstance in objects by which the emotions of grandeur and sublimity are produced; sometimes the emotions themselves.

In handling the present subject, it is necessary that the impression made on the mind by the magnitude of an object, abstracting from its other qualities, should be ascertained. And because abstraction is a mental operation of some difficulty, the safest method for judging is, to choose a plain object that is neither beautiful nor deformed, if such a one can be found. The plainest that occurs, is a huge mass of rubbish, the ruins perhaps of some extensive building; or a large heap of stones, such as are collected together for keeping in memory a battle or other remarkable event. Such an object, which in miniature would be perfectly indifferent, makes an impression by its magnitude, and appears agreeable. And supposing it so large as to fill the eye, and to prevent the attention from wandering upon other objects, the impression it makes will be so much the deeper. See *ATTENTION*.

But though a plain object of that kind be agreeable it is not termed *grand*: it is not entitled to that character, unless, together with its size, it be possessed of other qualities that contribute to beauty, such as regularity, proportion, order, or colour: and according to the number of such qualities combined with magnitude, it is more or less grand. Thus St Peter's church at Rome, the great pyramid of Egypt, the Alps towering above the clouds, a great arm of the sea, and above all a clear and serene sky, are grand; because, beside their size, they are beautiful in an eminent degree. On the other hand, an overgrown whale, having a disagreeable appearance, is not grand. A large building, agreeable by its regularity and proportions, is grand; and yet a much larger building, destitute of regularity, has not the least tincture of grandeur. A single regiment in battle-array, makes a grand appearance; which the surrounding crowd does not, though perhaps ten for one in number. And a regiment where the men are all in one livery, and the horses of one colour, makes a grander appearance, and consequently strikes more terror, than where there is confusion of colour and dress. Thus greatness or magnitude is the circumstance that distinguishes grandeur from beauty: agreeableness is the genus, of which beauty and grandeur are species.

The emotion of grandeur, duly examined, will be found

Grand
||
Grandeur
and
Sublimity.

Double sig-
nification.

Grandeur
is distinguish-
ed from
beauty.

Grandeur
and
Sublimity.

found an additional proof of the foregoing doctrine. That this emotion is pleasant in a high degree, requires no other evidence but once to have seen a grand object: and if an emotion of grandeur be pleasant, its cause or object, as observed above, must infallibly be agreeable in proportion.

The qualities of grandeur and beauty are not more distinct, than the emotions are which these qualities produce in a spectator. It is observed in the article BEAUTY, that all the various emotions of beauty have one common character, that of sweetness and gaiety. The emotion of grandeur has a different character: a large object that is agreeable, occupies the whole attention, and swells the heart into a vivid emotion, which, though extremely pleasant, is rather serious than gay. And this affords a good reason for distinguishing in language these different emotions. The emotions raised by colour, by regularity, by proportion, and by order, have such a resemblance to each other, as readily to come under one general term, viz. *the emotion of beauty*; but the emotion of grandeur is so different from these mentioned, as to merit a peculiar name.

3
Demands
not strict
regularity.

Though regularity, proportion, order, and colour, contribute to grandeur as well as to beauty, yet these qualities are not by far so essential to the former as to the latter. To make out that proposition, some preliminaries are requisite. In the first place, the mind, not being totally occupied with a small object, can give its attention at the same time to every minute part; but in a great or extensive object, the mind, being totally occupied with the capital and striking parts, has no attention left for those that are little or indifferent. In the next place, two similar objects appear not similar when viewed at different distances: the similar parts of a very large object, cannot be seen but at different distances; and for that reason, its regularity, and the proportion of its parts, are in some measure lost to the eye: neither are the irregularities of a very large object so conspicuous as of one that is small. Hence it is, that a large object is not so agreeable by its regularity, as a small object; nor so disagreeable by its irregularities.

4
Qualities
contributing to
grandeur.

These considerations make it evident, that grandeur is satisfied with a less degree of regularity, and of the other qualities mentioned, than is requisite for beauty; which may be illustrated by the following experiment. Approaching to a small conical hill, we take an accurate survey of every part, and are sensible of the slightest deviation from regularity and proportion. Supposing the hill to be considerably enlarged, so as to make us less sensible of its regularity, it will upon that account appear less beautiful. It will not, however, appear less agreeable, because some slight emotion of grandeur comes in place of what is lost in beauty. And at last, when the hill is enlarged to a great mountain, the small degree of beauty that is left, is sunk in its grandeur. Hence it is, that a towering hill is delightful, if it have but the slightest resemblance of a cone; and a chain of mountains not less so, though deficient in the accuracy of order and proportion. We require a small surface to be smooth; but in an extensive plain, considerable inequalities are overlooked. In a word, regularity, proportion, order,

and colour, contribute to grandeur as well as to beauty; but with a remarkable difference, that in passing from small to great, they are not required in the same degree of perfection. This remark serves to explain the extreme delight we have in viewing the face of nature, when sufficiently enriched and diversified with objects. The bulk of the objects in a natural landscape are beautiful, and some of them grand: a flowing river, a spreading oak, a round hill, an extended plain, are delightful; and even a rugged rock, or barren heath, though in themselves disagreeable, contribute by contrast to the beauty of the whole; joining to these the verdure of the fields, the mixture of light and shade, and the sublime canopy spread over all, it will not appear wonderful, that so extensive a group of splendid objects should swell the heart to its utmost bounds, and raise the strongest emotion of grandeur. The spectator is conscious of an enthusiasm which cannot bear confinement, nor the strictness of regularity and order: he loves to range at large; and is so enchanted with magnificent objects, as to overlook slight beauties or deformities.

The same observation is applicable in some measure to works of art. In a small building, the slightest irregularity is disagreeable: but in a magnificent palace, or a large Gothic church, irregularities are less regarded. In an epic poem, we pardon many negligences that would not be permitted in a sonnet or epigram. Notwithstanding such exceptions, it may be justly laid down for a rule, That in works of art, order and regularity ought to be governing principles; and hence the observation of Longinus, "In works of art we have regard to exact proportion; in those of nature, to grandeur and magnificence."

The same reflections are in a good measure applicable to sublimity: particularly that, like grandeur, it is a species of agreeableness; that a beautiful object placed high, appearing more agreeable than formerly, produces in the spectator a new emotion, termed *the emotion of sublimity*; and that the perfection of order, regularity, and proportion, is less required in objects placed high, or at a distance, than at hand.

The pleasant emotion raised by large objects, has not escaped the poets:

—————He doth bestride the narrow world
Like a colossus; and we petty men
Walk under his huge legs.

Julius Caesar, act i. sc. 3.

Cleopatra. I dreamt there was an emperor Antony:
Oh such another sleep, that I might see
But such another man!
His face was as the heav'ns: and therein stuck
A sun and moon, which kept their course, and lighted
The little O o' th' earth.
His legs bestrid the ocean, his rear'd arm
Crested the world.

Antony and Cleopatra, act v. sc. 3.

—————Majesty
Dies not alone; but, like a gulf, doth draw
What's near it with it. It's a massy wheel
Fix'd on the summit of the highest mount;
To whose huge spokes ten thousand lesser things

Are

Grandeur
and
Sublimity.

Are mortis'd and adjoin'd ; which, when it falls,
Each small annexment, petty consequence,
Attends the boist'rous ruin. *Hamlet*, act iii. sc. 8.

The poets have also made good use of the emotion
produced by the elevated situation of an object :

Quod si me lyricis vatibus inseres,
Sublimi feriam sidera vertice.

HORAT. *Carm.* l. ii. ode 1.

O thou ! the earthly author of my blood,
Whose youthful spirit, in me regenerate,
Doth with a twofold vigour lift me up,
To reach at victory above my head.

Richard II. act i. sc. 4.

Northumberland, thou ladder wherewithal
The mounting Bolingbroke ascends my throne.

Richard II. act v. sc. 2.

Antony. Why was I rais'd the meteor of the world,
Hung in the skies : and blazing as I travell'd,
Till all my fires were spent ; and then cast downward,
To be trod out by Cæsar ?

DRYDEN, *All for Love*, act i.

The description of Paradise in the fourth book of
Paradise Lost, is a fine illustration of the impression
made by elevated objects.

So on he fares, and to the border comes
Of Eden, where delicious Paradise,
Now nearer, crowns with her inclosure green,
As with a rural mound, the champain head
Of a steep wilderness ; whose hairy sides
With thicket overgrown, grotesque and wild,
Access deny'd ; and over head up grew
Insuperable height of loftiest shade,
Cedar, and pine, and fir, and branching palm,
A silvan scene ; and as the ranks ascend,
Shade above shade, a woody theatre
Of stateliest view. Yet higher than their tops
The verd'rous wall of Paradise up sprung ;
Which to our general sire gave prospect large
Into his nether empire, neighb'ring round.
And higher than that wall a circling row
Of goodliest trees, loaden with fairest fruit,
Blossoms and fruits at once of golden hue,
Appear'd, with gay enamell'd colours mix'd.

l. 131.

Though a grand object is agreeable, we must not infer that a little object is disagreeable ; which would be unhappy for man, considering that he is surrounded with so many objects of that kind. The same holds with respect to place : a body placed high is agreeable ; but the same body placed low, is not by that circumstance rendered disagreeable. Littleness and lowness of place are precisely similar in the following particular, that they neither give pleasure nor pain. And in this may visibly be discovered peculiar attention in fitting the internal constitution of man to his external circumstances. Were littleness and lowness of place agreeable, greatness and elevation could not be so ; were littleness and lowness of place disagreeable, they would occasion uninterrupted uneasiness.

The difference between great and little with respect

2

to agreeableness, is remarkably felt in a series when we pass gradually from one extreme to the other. A mental progress from the capital to the kingdom, from that to Europe—to the whole earth—to the planetary system—to the universe, is extremely pleasant : the heart swells, and the mind is dilated at every step. The returning in an opposite direction is not positively painful, though our pleasure lessens at every step, till it vanish into indifference : such a progress may sometimes produce pleasure of a different sort, which arises from taking a narrower and narrower inspection. The same observation holds in a progress upward and downward. Ascent is pleasure because it elevates us ; but descent is never painful : it is for the most part pleasant from a different cause, that it is according to the order of nature. The fall of a stone from any height, is extremely agreeable by its accelerated motion. We feel it pleasant to descend from a mountain, because the descent is natural and easy. Neither is looking downward painful ; on the contrary, to look down upon objects, makes part of the pleasure of elevation : looking down becomes then only painful when the object is so far below as to create dizziness ; and even when that is the case, we feel a sort of pleasure mixed with the pain : witness Shakespeare's description of Dover cliffs :

Grandeur
and
Sublimity.

—How fearful

And dizzy 'tis, to cast one's eye so low !
The crows and choughs, that wing the midway air,
Show scarce so gross as beetles. Half-way down
Hangs one that gathers samphire ; dreadful trade !
Methinks he seems no bigger than his head.
The fishermen that walk upon the beach
Appear like mice ; and yon tall anchoring bark
Diminish'd to her cock ; her cock, a buoy
Almost too small for sight. The murm'ring surge,
That on th' unnumbered idle pebbles chafes,
Cannot be heard so high. I'll look no more,
Lest my brain turn, and the deficient sight
Topple down headlong. *King Lear*, act iv. sc. 6.

A remark is made above, that the emotions of grandeur and sublimity are nearly allied. And hence it is, that the one term is frequently put for the other : an increasing series of numbers, for example, producing an emotion similar to that of mounting upward, is commonly termed an *ascending series* : a series of numbers gradually decreasing, producing an emotion similar to that of going downward, is commonly termed a *descending series* : we talk familiarly of going up to the capital, and of going down to the country : from a lesser kingdom we talk of going up to a greater ; whence the *anabasis* in the Greek language, when one travels from Greece to Persia. We discover the same way of speaking in the language even of Japan ; and its universality proves it the offspring of a natural feeling.

The foregoing observation leads us to consider grandeur and sublimity in a figurative sense, and as applicable to the fine arts. Hitherto these terms have been taken in their proper sense as applicable to objects of sight only : and it was of importance to bestow some pains upon that article : because, generally speaking, the figurative sense of a word is derived from its proper sense, which holds remarkably at present.

Beauty

Grandeur
and
Sublimity.

Beauty, in its original signification, is confined to objects of sight; but as many other objects, intellectual as well as moral, raise emotions resembling that of beauty, the resemblance of the effects prompts us to extend the term *beauty* to these objects. This equally accounts for the terms *grandeur* and *sublimity* taken in a figurative sense. Every emotion, from whatever cause proceeding, that resembles an emotion of grandeur or elevation, is called by the same name: thus generosity is said to be an *elevated* emotion, as well as great courage; and that firmness of soul which is superior to misfortunes obtains the peculiar name of *magnanimity*. On the other hand, every emotion that contracts the mind, and fixeth it upon things trivial or of no importance, is termed *low*, by its resemblance to an emotion produced by a little or low object of sight: thus an appetite for trifling amusements is called a *low taste*. The same terms are applied to characters and actions: we talk familiarly of an *elevated* genius, of a great man, and equally so of *littleness* of mind: some actions are *great* and *elevated*, and others are *little* and *grovelling*. Sentiments, and even expressions, are characterized in the same manner: an expression or sentiment that raises the mind is denominated *great* or *elevated*; and hence the **SUBLIME** in poetry. In such figurative terms, we lose the distinction between *great* and *elevated* in their proper sense; for the resemblance is not so entire as to preserve these terms distinct in their figurative application. We carry this figure still farther. Elevation, in its proper sense, imports superiority of place; and lowness, inferiority of place: and hence a man of *superior* talents, of *superior* rank; of *inferior* parts, of *inferior* taste, and such like. The veneration we have for our ancestors, and for the ancients in general, being similar to the emotion produced by an elevated object of sight, justifies the figurative expression of the ancients being *raised* above us, or possessing a *superior* place. The notes of the gamut, proceeding regularly from the blunter or grosser sounds to the more acute and piercing, produce in the hearer a feeling somewhat similar to what is produced by ascending upward; and this gives occasion to the figurative expressions, a *high note*, a *low note*.

Such is the resemblance in feeling between real and figurative grandeur, that among the nations on the east coast of Africa, who are directed purely by nature, the officers of state are, with respect to rank, distinguished by the length of the baton each carries in his hand; and in Japan, princes and great lords show their rank by the length and size of their sedan-poles. Again, it is a rule in painting, that figures of a small size are proper for grotesque pieces: but that an historical subject, grand and important, requires figures as great as the life. The resemblance of these feelings is in reality so strong, that elevation in a figurative sense is observed to have the same effect, even externally, with real elevation.

K. Henry. This day is call'd the feast of Crispian.
He that outlives this day, and comes safe home,
Will stand a tiptoe when this day is nam'd,
And rouse him at the name of Crispian.

Henry V. act iv. sc. 8.

Grandeur
and
Sublimity.

The resemblance in feeling between real and figurative grandeur is humorously illustrated by Addison in criticising upon English tragedy †. “The ordinary method of making a hero is to clap a huge plume of feathers upon his head, which rises so high, that there is often a greater length from his chin to the top of his head than to the sole of his foot. One would believe, that we thought a great man and a tall man the same thing. As these superfluous ornaments upon the head make a great man, a princess generally receives her grandeur from those additional incumbrances that fall into her tail: I mean the broad sweeping train that follows her in all her motions, and finds constant employment for a boy who stands behind her to open and spread it to advantage.” The Scythians, impressed with the fame of Alexander, were astonished when they found him a little man.

A gradual progress from small to great is not less remarkable in figurative than in real grandeur or elevation. Every one must have observed the delightful effect of a number of thoughts or sentiments, artfully disposed like an ascending series, and making impressions deeper and deeper: such disposition of members in a period is termed a *climax*.

Within certain limits grandeur and sublimity produce their strongest effects, which lessen by excess as well as by defect. This is remarkable in grandeur and sublimity taken in their proper sense: the grandest emotion that can be raised by a visible object is where the object can be taken in at one view: if so immense as not to be comprehended but in parts, it tends rather to distract than satisfy the mind (A): in like manner, the strongest emotion produced by elevation is where the object is seen distinctly; a greater elevation lessens in appearance the object, till it vanish out of sight with its pleasant emotions. The same is equally remarkable in figurative grandeur and elevation; which shall be handled together, because, as observed above, they are scarcely distinguishable. Sentiments may be so strained as to become obscure, or to exceed the capacity of the human mind: against such license of imagination, every good writer will be upon his guard. And therefore it is of greater importance to observe, that even the true sublime may be carried beyond that pitch which produces the highest entertainment. We are undoubtedly susceptible of a greater elevation than can be inspired by human actions the most heroic and magnanimous; witness what we feel from Milton's description of superior beings: yet every man must be sensible of a more constant and sweet elevation when the history of his own species is the

(x) It is justly observed by Addison, that perhaps a man would have been more astonished with the majestic air that appeared in one of Lysippus's statues of Alexander, though no bigger than the life, than he might have been with Mount Athos, had it been cut into the figure of the hero, according to the proposal of Phidias, with a river in one hand and a city in the other. *Spectator*, N^o 415.

Grandeur
and
Sublimity.

the subject: he enjoys an elevation equal to that of the greatest hero, of an Alexander or a Cæsar, of a Brutus or an Epaminondas: he accompanies these heroes in their sublimest sentiments and most hazardous exploits, with a magnanimity equal to theirs; and finds it no stretch to preserve the same tone of mind for hours together without sinking. The case is not the same in describing the actions or qualities of superior beings: the reader's imagination cannot keep pace with that of the poet; the mind, unable to support itself in a strained elevation, falls as from a height; and the fall is immoderate like the elevation: where that effect is not felt, it must be prevented by some obscurity in the conception, which frequently attends the descriptions of unknown objects. Hence the St Francis, St Dominics, and other tutelary saints among the Roman Catholics. A mind unable to raise itself to the Supreme Being self-existent and eternal, or to support itself in a strained elevation, finds itself more at ease in using the intercession of some saint whose piety and penances while on earth are supposed to have made him a favourite in heaven.

A strained elevation is attended with another inconvenience, that the author is apt to fall suddenly as well as the reader; because it is not a little difficult to descend, sweetly and easily, from such elevation to the ordinary tone of the subject. The following passage is a good illustration of that observation:

Sæpe etiam immensum cœlo venit agmen aquarum,
Et fœdam glomerant tempestatem imbribus atris
Collectæ ex alto nubes. Ruit ardens æther,
Et pluvia ingenti sata læta, bonique labores
Diluit. Implentur fossæ, et cava flumina crescunt
Cum sonitu, fervetque fretis spirantibus æquor.
Ipse Pater, mediâ nimborum in nocte, corusca
Fulmina molitur dextra. Quo maxima motu
Terra tremit: fugere feræ, et mortalia corda
Per gentes humilis stravit pavor. Ille flagranti
Aut Atho, aut Rhodopen, aut alta Ceraunia telo
Dejicit: *ingeminant Austri, et densissimus imber.*

VIRG. *Georg.* i. 322.

In the description of a storm, to figure Jupiter throwing down huge mountains with his thunderbolts, is hyperbolically sublime, if we may use the expression: the tone of mind produced by that image is so distant from the tone produced by a thick shower of rain, that the sudden transition must be unpleasant.

Objects of sight that are not remarkably great nor high, scarce raise any emotion of grandeur or of sublimity: and the same holds in other objects; for we often find the mind roused and animated, without being carried to that height. This difference may be discerned in many sorts of music, as well as in some musical instruments: a kettle-drum rouses, and a haut-boy is animating; but neither of them inspires an emotion of sublimity: revenge animates the mind in a considerable degree; but it never produceth an emotion that can be termed *grand* or *sublime*; and perhaps no disagreeable passion ever has that effect.

No desire is more universal than to be exalted and honoured; and upon that account, chiefly, are we ambitious of power, riches, titles, fame, which would suddenly lose their relish did they not raise us above

others, and command submission and deference: and it may be thought that our attachment to things grand and lofty, proceeds from their connection with our favourite passion. This connection has undoubtedly an effect; but that the preference given to things grand and lofty must have a deeper root in human nature, will appear from considering, that many bestow their time upon low and trifling amusements, without having the least tincture of this favourite passion: yet these very persons talk the same language with the rest of mankind; and prefer the more elevated pleasures: they acknowledge a more refined taste, and are ashamed of their own as low and grovelling. This sentiment, constant and universal, must be the work of nature; and it plainly indicates an original attachment in human nature to every object that elevates the mind: some men may have a greater relish for an object not of the highest rank; but they are conscious of the preference given by mankind in general to things grand and sublime, and they are sensible that their peculiar taste ought to yield to the general taste.

What is said above suggests a capital rule for reaching the sublime in such works of art as are susceptible of it; and that is, to present those parts or circumstances only which make the greatest figure, keeping out of view every thing low or trivial; for the mind, elevated by an important object, cannot, without reluctance, be forced down to bestow any share of its attention upon trifles. Such judicious selection of capital circumstances, is by an eminent critic styled *grandeur of manner* *. In none of the fine arts is there so great scope for that rule as in poetry; which, by that means, enjoys a remarkable power of bestowing upon objects and events an air of grandeur: when we are spectators, every minute object presents itself in its order; but in describing at second hand, these are laid aside, and the capital objects are brought close together. A judicious taste in thus selecting the most interesting incidents, to give them an united force, accounts for a fact that may appear surprising; which is, that we are more moved by spirited narrative at second hand, than by being spectators of the event itself, in all its circumstances.

Longinus † exemplifies the foregoing rule by a comparison of two passages.

Ye pow'rs, what madness! how on ships so frail
(Tremendous thought!) can thoughtless mortals sail?
For stormy seas they quit the pleasing plain,
Plant woods in waves, and dwell amidst the main.
Far o'er the deep (a trackless path) they go,
And wander oceans in pursuit of wo.
No ease their hearts, no rest their eyes can find,
On heaven their looks, and on the waves their mind;
Sunk are their spirits, while their arms they rear,
And gods are wearied with their fruitless prayer.

ARISTÆUS.

Burst as a wave that from the cloud impends,
And swell'd with tempests on the ship descends.
White are the decks with foam: the winds aloud
Howl o'er the masts, and sing through every shroud.
Pale, trembling, tir'd, the sailors freeze with fears,
And instant death on every wave appears.

HOMER.

In the latter passage, the most striking circumstances are selected to fill the mind with terror and astonishment. The former is a collection of minute and low circumstances, which scatter the thought, and make no impression: it is at the same time full of verbal antitheses and low conceit, extremely improper in a scene of distress.

The following description of a battle is remarkably sublime, by collecting together, in the fewest words, those circumstances which make the greatest figure.

“ Like autumn’s dark storms pouring from two echoing hills, toward each other approached the heroes; as two dark streams from high rocks meet and roar on the plain, loud, rough, and dark in battle, meet Lochlin and Inisfail. Chief mixes his strokes with chief, and man with man: steel sounds on steel, and helmets are cleft on high: blood bursts and smokes around: strings murmur on the polish’d yew: darts rush along the sky: spears fall like sparks of flame that gild the stormy face of night.

“ As the noise of the troubled ocean when roll the waves on high, as the last peal of thundering heaven, such is the noise of battle. Though Cormac’s hundred bards were there, feeble were the voice of a hundred bards to send the deaths to future times; for many were the deaths of the heroes, and wide poured the blood of the valiant.” FINGAL.

The following passage in the 4th book of the Iliad is a description of a battle wonderfully ardent.— “ When now gathered on either side, the host plunged together in fight; shield is harshly laid to shield; spears crash on the brazen corslets: bossy buckler with buckler meets; loud tumult rages over all; groans are mixed with boasts of men; the slain and slayer join in noise; the earth is floating round with blood. As when two rushing streams from two mountains come roaring down, and throw together their rapid waters below, they roar along the gulphy vale; the startled shepherd hears the sound as he stalks o’er the distant hills: so, as they mixed in fight, from both armies clamour with loud terror arose.” But such general descriptions are not frequent in Homer. Even his single combats are rare. The fifth book is the longest account of a battle that is in the Iliad; and yet contains nothing but a long catalogue of chiefs killing chiefs, not in single combat neither, but at a distance with an arrow or a javelin; and these chiefs named for the first time and the last. The same scene is continued through a great part of the sixth book. There is at the same time a minute description of every wound, which for accuracy may do honour to an anatomist, but in an epic poem is tiresome and fatiguing. There is no relief from horrid languor, but the beautiful Greek language and melody of Homer’s versification.

In the twenty-first book of the Odyssey, there is a passage which deviates widely from the rule above laid down: it concerns that part of the history of Penelope and her suitors, in which she is made to declare in favour of him who should prove the most dexterous in shooting with the bow of Ulysses:

Now gently winding up the fair ascent,
By many an easy step the matron went:
VOL. X. Part I.

†

Then o’er the pavements glides with grace divine
(With polish’d oak the level pavements shine).
The folding gates a dazzling light display’d,
With pomp of various architrate o’erlaid.
The bolt, obedient to the silken string,
Forsakes the staple as she pulls the ring;
The wards respondent to the key turn round;
The bars fall back; the flying valves resound.
Loud as a bull makes hill and valley ring,
So roar’d the lock when it releas’d the spring.
She moves majestic through the wealthy room,
Where treasur’d garments cast a rich perfume:
There, from the column where aloft it hung,
Reach’d, in its splendid case, the bow unstrung.

Virgil sometimes errs against this rule: in the following passages minute circumstances are brought into full view; and what is still worse, they are described with all the pomp of poetical diction, *Æneid*, lib. i. l. 214. to 219. lib. vi. l. 176. to 182. lib. vi. l. 212. to 231.: and the last, which describes a funeral, is the less excusable, as the man whose funeral it is makes no figure in the poem.

The speech of Clytemnestra, descending from her chariot, in the *Iphigenia* of Euripides, is stuffed with a number of common and trivial circumstances. * Act iii.

But of all writers, Lucan in this article is the most injudicious: the sea fight between the Romans and Massilians † is described so much in detail, without exhibiting any grand or total view, that the reader is fatigued with endless circumstances, without ever feeling any degree of elevation; and yet there are some fine incidents, those, for example, of the two brothers, and of the old man and his son, which, taken separately, would affect us greatly. But Lucan, once engaged in a description, knows no end. See other passages of the same kind, lib. iv. l. 292. to 337. lib. iv. l. 750. to 765. The episode of the sorceress Erictho, end of book sixth, is intolerably minute and prolix. † Lib. iii.

This rule is also applicable to other fine arts. In painting it is established, that the principal figure must be put in the strongest light; that the beauty of attitude consists in placing the nobler parts most in view, and in suppressing the smaller parts as much as possible; that the folds of the drapery must be few and large; that foreshortenings are bad, because they make the parts appear little; and that the muscles ought to be kept as entire as possible, without being divided into small sections. Every one at present subscribes to that rule as applied to gardening, in opposition to parterres split into a thousand small parts in the stiffest regularity of figure. The most eminent architects have governed themselves by the same rules in all their works.

Another rule chiefly regards the sublime, though it is applicable to every sort of literary performance intended for amusement: and that is, to avoid as much as possible abstract and general terms. Such terms, similar to mathematical signs, are contrived to express our thoughts in a concise manner; but images, which are the life of poetry, cannot be raised in any perfection but by introducing particular objects. General terms, that comprehend a number of individuals, must be expected from that rule: our kindred, our clan, our country, and words of the like import, though they

K

Grandeur
and
Sublimity.

scarce raise any image, have, however, a wonderful power over the passions: the greatness of the complex object overbalances the obscurity of the image.

Grandeur, being an extremely vivid emotion, is not readily produced in perfection but by reiterated impressions. The effect of a single impression can be but momentary; and if one feel suddenly somewhat like a swelling or exaltation of mind, the emotion vanishes as soon as felt. Single thoughts or sentiments are often cited as examples of the sublime; but their effect is far inferior to that of a grand subject displayed in its capital parts. We shall give a few examples, that the reader may judge for himself. In the famous action of Thermopylæ, where Leonidas the Spartan king, with his chosen band, fighting for their country, were cut off to the last man, a saying is reported of Dienece, one of the band, which, expressing cheerful and undisturbed bravery, is well entitled to the first place in examples of that kind: talking of the number of their enemies, it was observed, that the arrows shot by such a multitude would intercept the light of the sun; "So much the better (says he), for we shall then fight in the shade."

Herodot.
lib. 7.

Somersct. Ah! Warwick, Warwick, wert thou as we are

We might recover all our loss again.

The Queen from France hath brought a puissant power. Ev'n now we heard the news. Ah! couldst thou fly!

Warwick. Why, then I would not fly.

Third part, Henry VI. act v. sc. 3.

Such a sentiment from a man expiring of his wounds, is truly heroic; and must elevate the mind to the greatest height that can be done by a single expression; it will not suffer in a comparison with the famous sentiment *Qu'il mourut* of Corneille: the latter is a sentiment of indignation merely, the former of firm and cheerful courage.

To cite in opposition many a sublime passage, enriched with the finest images, and dressed in the most nervous expressions, would scarce be fair. We shall produce but one instance, from Shakespeare, which sets a few objects before the eye, without much pomp of language: it operates its effect by representing these objects in a climax, raising the mind higher and higher till it feel the emotion of grandeur in perfection:

The cloud-capt tow'rs, the gorgeous palaces,
The solemn temples, the great globe itself,
Yea, all which it inherit, shall dissolve, &c.

The cloud-capt tow'rs produce an elevating emotion, heightened by the *gorgeous palaces*; and the mind is carried still higher and higher by the images that follow. Successive images, making thus stronger and stronger impressions, must elevate more than any single image can do.

14
Grandeur
and subli-
mity em-
ployed in-
directly to
sink the
mind.

As, on the one hand, no means directly applied have more influence to raise the mind than grandeur and sublimity; so, on the other, no means indirectly applied have more influence to sink and depress it: for in a state of elevation, the artful introduction of an humbling object, makes the fall great in proportion to the elevation. Of this observation Shakespeare gives a beautiful example in the passage last quoted:

The cloud-capt tow'rs, the gorgeous palaces,
The solemn temples, the great globe itself,
Yea, all which it inherit, shall dissolve,
And like the baseless fabric of a vision
Leave not a wreck behind—*Tempest*, act iv. sc. 4.

Grandeur
and
Sublimity.

The elevation of the mind in the former part of this beautiful passage, makes the fall great in proportion, when the most humbling of all images is introduced, that of an utter dissolution of the earth and its inhabitants. The mind, when warmed, is more susceptible of impressions than in a cool state; and a depressing or melancholy object listened to, makes the strongest impression when it reaches the mind in its highest state of elevation or cheerfulness.

But a humbling image is not always necessary to produce that effect: a remark is made above, that in describing superior beings, the reader's imagination, unable to support itself in a strained elevation, falls often as from a height, and sinks even below its ordinary tone. The following instance comes luckily in view; for a better cannot be given: "God said, Let there be light, and there was light." Longinus quotes this passage from Moses as a shining example of the sublime; and it is scarce possible, in fewer words, to convey so clear an image of the infinite power of the Deity: but then it belongs to the present subject to remark, that the emotion of sublimity raised by this image is but momentary; and that the mind, unable to support itself in an elevation so much above nature, immediately sinks down into humility and veneration for a Being so far exalted above grovelling mortals. Every one is acquainted with a dispute about that passage between two French critics*, the one positively affirming it to be sublime, the other as positively denying. What has been remarked, shows, that both of them have reached the truth, but neither of them the whole truth: the primary effect of the passage is undoubtedly an emotion of grandeur; which so far justifies Boileau: but then every one must be sensible, that the motion is merely a flash, which, vanishing instantaneously, gives way to humility and veneration. That indirect effect of sublimity justifies Huet, on the other hand, who being a man of true piety, and probably not much carried by imagination, felt the humbling passions more sensibly than his antagonist did. And laying aside difference of character, Huet's opinion may perhaps be defended as the more solid; because, in such images, the depressing emotions are the more sensibly felt, and have the longer endurance.

* Boileau
and Huet

The straining an elevated subject beyond due bounds, ¹³ false sub-
and beyond the reach of an ordinary conception, is lime.
not a vice so frequent as to require the correction of criticism. But false sublime is a rock that writers of more fire than judgment commonly split on; and therefore a collection of examples may be of use as a beacon to future adventurers. One species of false sublime, known by the name of *bambast*, is common among writers of a mean genius; it is a serious endeavour, by strained description, to raise a low or familiar subject above its rank; which, instead of being sublime, fails not to be ridiculous. The mind, indeed, is extremely prone, in some animating passions, to magnify its objects

jects beyond natural bounds: but such hyperbolical description has its limits; and when carried beyond the impulse of the propensity, it degenerates into burlesque. Take the following examples:

Sejanus. ————— Great and high
The world knows only two, that's Rome and I.
My roof receives me not: 'tis air I tread,
And at each step I feel my advanc'd head
Knock out a star in heav'n's.

BEN JOHNSON, *Sejanus*, act v.

A writer who has no natural elevation of mind deviates readily into bombast: he strains above his natural powers; and the violent effort carries him beyond the bounds of propriety.

Guildford. Give way, and let the gushing torrent
come;
Behold the tears we bring to swell the deluge,
Till the flood rise upon the guilty world,
And make the ruin common.

Lady Jane Gray, act iv. near the end.

Another species of false sublime is still more faulty than bombast: and that is, to force elevation by introducing imaginary beings without preserving any propriety in their actions; as if it were lawful to ascribe every extravagance and inconsistency to beings of the poet's creation. No writers are more licentious in that article than Johnson and Dryden.

Methinks I see Death and the Furies waiting
What we will do, and all the heaven at leisure
For the great spectacle. Draw then your swords:
And if our destiny envy our virtue
The honour of the day, yet let us care
To sell ourselves at such a price, as may
Undo the world to buy us, and make Fate,
While she tempts ours, to fear her own estate.

Catiline, act v.

—————The Furies stood on hills
Circling the place, and trembled to see men
Do more than they: whilst Piety left the field,
Griev'd for that side, that in so bad a cause
They knew not what a crime their valour was.
The sun stood still, and was, behind the cloud
The battle made, seen sweating to drive up
His frighted horse, whom still the noise drove back-
wards.

Ibid, act v.

Osmyn. While we indulge our common happiness,
He is forgot by whom we all possess,
The brave Almanzor, to whose arms we owe
All that we did, and all that we shall do;
Who like a tempest that outrides the wind,
Made a just battle ere the bodies join'd.

Abdalla. His victories we scarce could keep in view,
Or polish 'em so fast as he rough drew.

Abdemelech. Fate after him below with pain did
move,

And Victory could scarce keep pace above.
Death did at length so many slain forget,
And lost the tale, and took 'em by the great.

Conquest of Granada, act ii. at beginning.

An actor on the stage may be guilty of bombast as well as an author in his closet: a certain manner of acting, which is grand when supported by dignity in the sentiment and force in the expression, is ridiculous where the sentiment is mean and the expression flat.

GRANDGOR is used in Scotland for the pox. In the Philosophical Transactions, N^o 469. sect. 5. we have a proclamation of King James IV. of Scotland, ordering all who had this disease, or who had attended others under it, forthwith to repair to an island (Inchkeith) in the frith of Forth. If the grandgor was the pox, and this distemper came into Europe at the siege of Naples in 1495, it must have made a very quick progress to cause such an alarm at Edinburgh in 1497.

GRANGE, an ancient term for a barn or place wherein to lay up and thresh corn. The word is formed of the Latin *granea*: or of *granum*, "grain, corn," &c. Hence also *granger* or *grangier*, "a grange-keeper or farmer."

GRANGE is also used, in a more extensive sense, for a whole farm, with all the appendages of stables for horses, stalls for cattle, &c. and for an inn.

GRANI, in our ancient writers, mustachoes or whiskers of a beard. The word seems formed from the ancient British or Irish *greann*, "a beard." It is given for a reason why the cup is refused to the laity, *Quia barbati, et prolixos habent granos, dum poculum inter epulas sumunt, prius liquore pilos inficiunt, quam ori infundunt.*

GRANICUS, a small river near the Hellespont in Lesser Asia, remarkable for the first victory gained by Alexander the Great over the armies of Darius.—Authors disagree very much about the number of the Persians, though all agree that they were vastly more numerous than the Greeks. Justin and Orosius tell us, that the Persian army consisted of 600,000 foot and 20,000 horse; Arian makes the foot amount to 200,000; but Diodorus tells us, that they were not more than 100,000 foot and 10,000 horse. The Macedonian army did not exceed 30,000 foot and 5000 horse. The Persian cavalry lined the banks of the Granicus, in order to oppose Alexander wherever he should attempt a passage; and the foot were posted behind the cavalry on an easy ascent. Parmenio would have had Alexander to allow his troops some time to refresh themselves; but he replied, that after having crossed the Hellespont, it would be a disgrace to him and his troops to be stopped by a rivulet. Accordingly a proper place for crossing the river was no sooner found, than he commanded a strong detachment of horse to enter; he himself followed with the right wing, which he commanded in person; the trumpets in the mean time sounding, and loud shouts of joy being heard through the whole army. The Persians let fly such showers of arrows against the detachment of Macedonian horse as caused some confusion; several of their horses being killed or wounded. As they drew near the bank a most bloody engagement ensued; the Macedonians attempting to land, and the Persians pushing them back into the river. Alexander, who observed the confusion they were in, took the command of them himself; and landing in spite of all opposition, obliged the Persian cavalry, after an obstinate resistance,

Graniteus
Grant.

resistance, to give ground. However, Spithrobates, governor of Ionia, and son-in-law to Darius, still maintained his ground, and did all that lay in his power to bring them back to the charge. Alexander advanced full gallop to engage him; neither did he decline the combat, and both were slightly wounded at the first encounter. Spithrobates having thrown his javelin without effect, advanced sword in hand to meet his antagonist, who ran him through with his pike as he raised his arm to discharge a blow with his scimitar. But Rosaces, brother to Spithrobates, at the same time gave Alexander such a furious blow on the head with his battle-axe, that he beat off his plume, and slightly wounded him through the helmet. As he was ready to repeat the blow, Clitus with one stroke of his scimitar cut off Rosaces's head, and thus in all probability saved the life of his sovereign. The Macedonians then, animated by the example of their king, attacked the Persians with new vigour, who soon after betook themselves to flight. Alexander did not pursue them; but immediately charged the enemy's foot with all his forces, who had now passed the river. The Persians, disheartened at the defeat of their cavalry, made no great resistance. The Greek mercenaries retired in good order to a neighbouring hill, whence they sent deputies to Alexander, desiring leave to march off unmolested. But he, instead of coming to a parley with them, rushed furiously into the middle of this small body, where his horse was killed under him, and he himself in great danger of being cut in pieces. The Greeks defended themselves with incredible valour for a long time, but were at last almost entirely cut off. In this battle the Persians are said to have lost 20,000 foot and 2500 horse, and the Macedonians only 55 foot and 60 horse.

GRANITE, a compound rock which is considered as one of the oldest of which the earth is composed; as in most cases all other rocks are incumbent on granite. The constituent parts of granite are feld-spar, quartz, and mica, in very variable proportions. See **GEOLOGY Index**.

GRANITILLO, or **GRANITEL**, a name given by some mineralogists to a particular species or variety of granite, which contains also sometimes hornblende.

GRANIVOROUS, an appellation given to animals which feed on corn or seeds. These are principally of the bird kind.

GRANT, in *Law*, a conveyance in writing of such things as cannot pass or be conveyed by word only; such as rents, reversions, services, &c.

GRANT, *Francis*. Lord Cullen, an eminent lawyer and judge of Scotland, was descended from a younger branch of the family of the Grants of Grant in that kingdom, and was born about the year 1660. When he commenced advocate, he made a distinguished figure at the revolution, by opposing the opinion of the old lawyers, who warmly argued on the inability of the convention of estates to make any disposition of the crown. The abilities which he discovered in favour of the revolution introduced him to extensive practice; in which he acquired so much reputation, that when the union between the two kingdoms was in agitation, Queen Anne, without solicitation, created him a baronet, with a view of securing his interest in

that measure; and upon the same principle, she soon after created him a judge, or one of the lords of session. From this time, according to the custom of Scotland, he was styled, from the name of his estate, Lord Cullen: and the same good qualities that recommended him to this honourable office, were very conspicuous in the discharge of it; which he continued for 20 years with the highest reputation, when a period was put to his life by an illness which lasted but three days. He died March 16th, 1726. His character is drawn to great advantage in the *Biographia Britannica*; where it is observed, among other remarks to his honour, "That as an advocate he was indefatigable in the management of business; but at the same time that he spared no pains, he would use no craft. He had so high an idea of the dignity of his profession, that he held it equally criminal to neglect any honest means of coming at justice, or to make use of any arts to elude it. In respect to fortune, though he was modest and frugal, and had a large practice, yet he was far from being avaricious. His private charities were very considerable, and grew in the same proportion with his profits. He was, besides, very scrupulous in many points; he would not suffer a just cause to be lost through a client's want of money. He was such an enemy to oppression, that he never denied his assistance to such as laboured under it; and with respect to the clergy of all professions (in Scotland), his conscience obliged him to serve them without a fee. When his merit had raised him to the bench, he thought himself accountable to God and man for his conduct in that high office: and that deep sense of his duty, at the same time that it kept him strictly to it, encouraged and supported him in the performance. Whenever he sat as lord ordinary, the paper of causes was remarkably full; for his reputation being equally established for knowledge and integrity, there were none, who had a good opinion of their own pretensions, but were desirous of bringing them before him, and not many who did not sit down satisfied with his decision. This prevailed more especially after it was found that few of his sentences were reversed; and when they were, it was commonly owing to himself: for if, upon mature reflection, or upon new reasons offered at the re-hearing, he saw any just ground for altering his judgment, he made no scruple of declaring it; being persuaded that it was more manly, as well as more just, to follow truth, than to support opinion: and his conduct in this respect had a right effect; for instead of lessening, it raised his reputation. He would not, however, with all this great stock of knowledge, experience, and probity, trust himself on matters of blood, or venture to decide in criminal cases on the lives of his fellow-creatures; which was the reason that, though often solicited, he could never be prevailed upon to accept of a seat in the judicary court.—In his private character he was as amiable as he was respectable in his public. He was charitable without ostentation, disinterested in his friendships, and beneficent to all who had any thing to do with him. He was not only strictly just, but so free from any species of avarice, that his lady, who was a woman of great prudence and discretion, finding him more intent on the business committed to him by others than on his own, took upon herself the care of placing out his mo-

Grant.

Grant,
Granville.

ney; and to prevent his postponing, as he was apt to do, such kind of affairs, when securities offered, she caused the circumstances of them to be stated in the form of cases, and so procured his opinion upon his own concerns as if they had been those of a client. He was so true a lover of learning, and was so much addicted to his studies, that, notwithstanding the multiplicity of his business while at the bar, and his great attention to his charge when a judge, he nevertheless found time to write various treatises on very different and important subjects: Some political, which were remarkably well timed, and highly serviceable to the government: others of a most extensive nature, such as his essays on law, religion, and education, which were dedicated to George II. when prince of Wales; by whose command, his then secretary, Mr Samuel Molyneux, wrote him a letter of thanks, in which were many gracious expressions, as well in relation to the piece as to its author. He composed, besides these, many discourses on literary subjects, for the exercise of his own thoughts, and for the better discovery of truth: which went no farther than his own closet, and from a principle of modesty were not communicated even to his most intimate friends."

GRANTHAM, a town of Lincolnshire, 110 miles N. from London, situated on the river Witham. It is supposed to have been a Roman town by the remains of a castle which have been formerly dug up here. It is governed by an alderman and 12 justices of the peace, a recorder, a coroner, &c. Here is a fine large church with a stone spire, one of the loftiest in England, being 288 feet high, and, by the deception of the sight, seems to stand awry. Here is a free-school, where Sir Isaac Newton received his first education, besides two charity-schools. It contained 3646 inhabitants in 1811. W. Long. 1. 37. N. Lat. 52. 55.

GRANVILLE, GEORGE, Lord Lansdowne, was descended from a very ancient family, derived from Rollo the first duke of Normandy. At eleven years of age he was sent to Trinity College in Cambridge, where he remained five years: but at the age of 13 was admitted to the degree of master of arts; having, before he was 12, spoken a copy of verses of his own composition to the duchess of York at his college, when she paid a visit to the University of Cambridge. In 1696, his comedy called the *She-gallants* was acted at the theatre-royal in Lincoln's-inn-fields, as his tragedy called *Heroic Love* was in the year 1698. In 1702 he translated into English the *second Olynthian of Demosthenes*. He was member for the county of Cornwall in the parliament which met in 1710; was afterwards secretary of war, comptroller of the household, then treasurer, and sworn one of the privy council. The year following he was created Baron Lansdowne. On the accession of King George I. in 1714, he was removed from his treasurer's place; and the next year entered his protest against the bills for attainting Lord Bolingbroke and the duke of Ormond. He entered deeply into the scheme for raising an insurrection in the west of England; and being seized as a suspected person, was committed to the Tower, where he continued two years. In 1719, he made a speech in the house of lords, against the bill to prevent occasional conformity. In 1722, he withdrew to France, and continued abroad

almost ten years. At his return in 1732, he published a fine edition of his works in 2 vols quarto. He died in 1735, leaving no male issue.

GRANVILLE, a sea-port town of France, in Lower Normandy, partly seated on a rock and partly on a plain. It gave title to an English earl, now extinct. W. Long. 1. 32. N. Lat. 48. 50.

GRANULATED, something that has undergone granulation, or has been reduced to grains.

GRANULATION, in *Chemistry*, an operation by which metallic substances are reduced into small grains, or roundish particles; the use of which is, to facilitate their combination with other substances.—This operation is very simple; it consists only in pouring a melted metal slowly into a vessel filled with water, which is in the mean time to be agitated with a broom. Lead or tin may be granulated by pouring them when melted into a box; the internal surface of which is to be rubbed with powdered chalk, and the box strongly shaken till the lead has become solid. Metals are granulated, because their ductility renders them incapable of being pounded, and because filing is long and tedious, and might render the metal impure by any admixture of iron from the file.

GRAPE, the fruit of the vine. See **VINE** and **WINE**. See also **CURRENT** and **RAISIN**.

GRAPE-Shot, in artillery, is a combination of small shot, put into a thick canvas bag, and corded strongly together, so as to form a kind of cylinder, whose diameter is equal to that of the ball adapted to the cannon. The number of shot in a grape varies according to the service or size of the guns: in sea-service nine is always the number; but by land it is increased to any number or size from an ounce and a quarter in weight to three or four pounds. In sea-service the bottoms and pins are made of iron, whereas those used by land are of wood.

GRAPES, in the manege, a term used to signify the arrests or mangy tumours that happen in the horse's legs.

GRAPHOMETER, a mathematical instrument, otherwise called a *semicircle*; the use of which is to observe any angle whose vertex is at the centre of the instrument in any plane (though it is most commonly horizontal, or nearly so); and to find how many degrees it contains. See **MENSURATION**.

GRAPNEL, or **GRAPLING**, a sort of small anchor, fitted with four or five flukes or claws, and commonly used to ride a boat or other small vessel.

Fire-GRAPPLING, an instrument nearly resembling the former, but differing in the construction of its flukes, which are furnished with strong barbs on their points. These machines are usually fixed on the yard-arms of a ship, in order to grapple any adversary whom he intends to board. They are, however, more particularly useful in *FIRE Ships* for the purposes described in that article.

GRASS, in *Botany*, a plant having simple leaves, a stem generally jointed and tubular, a husky calyx (called *gluma*), and the seed single. For the classification of grasses, see **BOTANY Index**; and for an account of the culture, see **AGRICULTURE Index**.

GRASSHOPPER, a species of gryllus. See **GRYLLUS**, **ENTOMOLGGY Index**.

GRATES for **FIRES**, are composed of ribs of iron

Granville
Grates.

Grates placed at small distances from one another, so that the air may have sufficient access to the fuel, and the accumulation of the ashes, which would choke the fire, may be prevented.—Grates seem peculiarly adapted to the use of pit-coal, which requires a greater quantity of air to make it burn freely than other kinds of fuel. The hearths of the Britons seem to have been fixed in the centre of their halls, as is yet practised in some parts of Scotland, where the fire is nearly in the middle of the house, and the family sit all around it. Their fire-place was perhaps nothing more than a large stone, depressed a little below the level of the ground, and thereby adapted to receive the ashes. About a century ago, it was only the floor of the room, with the addition of a bank or hob of clay. But it was now changed among the gentlemen for a portable fire-pan, raised upon low supporters, and fitted with a circular grating of bars. Such were in use among the Gauls in the first century, and among the Welsh in the tenth.

* See *Ar gentora.*

GRATIAN, the son of Valentinian I. by his first wife, was declared Augustus by his father at the city of Amiens in 365, and succeeded him in 367; a prince equally extolled for his wit, eloquence, modesty, chastity, and zeal against heretics. He associated Theodosius with him in the empire, and advanced the poet Ausonius to the consulate. He made a great slaughter of the Germans at Strasburg*, and hence was surnamed *Alemannicus*. He was the first emperor who refused the title of *Pontifex Maximus*, upon the score of its being a Pagan dignity. He was assassinated by Andragathius in 375, in the 24th year of his age.

GRATIAN, a famous Benedictine monk, in the 12th century, was born at Chiusi in Tuscany, and employed above 24 years in composing a work, entitled *Decretum*, or *Concordantia Discordantium Canonum*, because he there endeavoured to reconcile the canons which seemed contradictory to each other. This work was first printed at Mentz in 1472. As he is frequently mistaken; in taking one canon of one council, or one passage of one father for another, and has often cited false decretals, several authors have endeavoured to correct his faults; and chiefly Anthony Augustine, in his excellent work entitled *De emendatione Gratiani*. To the decretals of Gratian, the popes principally owed the great authority they exercised in the 13th and following centuries.

GRATINGS, in a ship, are small edges of sawed plank, framed one into another like a lattice or prison grate, lying on the upper deck, between the mainmast and foremast, serving for a defence in a close fight, and also for the coolness, light, and convenience of the ship's company.

GRATIOLA, HEDGE HYSSOP; a genus of plants belonging to the diandria class. See *BOTANY Index*.

GRATITUDE, in *Ethics*, a virtue disposing the mind to an inward sense and outward acknowledgment of benefits received.

Examples of ingratitude, Mr Paley observes, check and discourage voluntary beneficence; hence the cultivation of a grateful temper is a consideration of public importance. A second reason for cultivating in ourselves that temper is: That the same principle which is touched with the kindness of a human benefactor, is capable of being affected by the divine goodness, and

and of becoming, under the influence of that affection, a source of the purest and most exalted virtue. The love of God is the sublimest gratitude. It is a mistake, therefore, to imagine, that this virtue is omitted in the Scriptures; for every precept which commands us "to love God, because he first loved us," presupposes the principle of gratitude, and directs it to its proper object.

It is impossible to particularize the several expressions of gratitude, which vary with the character and situation of the benefactor, and with the opportunities of the person obliged; for this variety admits of no bounds. It may be observed, however, that on one part gratitude can never oblige a man to do what is wrong, and what by consequence he is previously obliged not to do: On the other part, it argues a total want of every generous principle, as well as of moral probity, to take advantage of that ascendancy, which the conferring of benefits justly creates, to draw or drive those whom we have obliged into mean or dishonest compliances.

The following pleasing example of genuine gratitude is extracted from *Hackwell's Apol.* lib. xiv. c. 10. p. 436.—Francis Frescobald, a Florentine merchant, descended of a noble family in Italy, had gained a plentiful fortune, of which he was liberal-handed to all in necessity; which being well known to others, though concealed by himself, a young stranger applied to him for charity. Signior Frescobald, seeing something in his countenance more than ordinary, overlooked his tattered clothes; and compassionating his circumstances, asked him "What he was, and of what country." "I am (answered the young man) a native of England; my name is Thomas Cromwell, and my father-in-law is a poor sheer-man. I left my country to seek my fortune; came with the French army that were routed at Gatyllion, where I was a page to a footman, and carried his pike and burget after him." Frescobald commiserating his necessities, and having a particular respect for the English nation, clothed him genteelly; took him into his house till he had recovered strength by better diet; and, at his taking leave, mounted him upon a good horse, with 16 ducats of gold in his pockets. Cromwell expressed his thankfulness in a very sensible manner, and returned by land towards England; where, being arrived, he was preferred into the service of Cardinal Wolsey. After the cardinal's death, he worked himself so effectually into the favour of King Henry VIII. that his majesty made him a baron, viscount, earl of Essex, and at last made him lord high chancellor of England. In the mean time, Signior Frescobald, by repeated losses at sea and land, was reduced to poverty; and calling to mind (without ever thinking of Cromwell), that some English merchants were indebted to him in the sum of 15,000 ducats, he came to London to procure payment. Travelling in pursuit of this affair, he fortunately met with the lord chancellor as he was riding to court; who thinking him to be the same gentleman that had done him such great kindness in Italy, he immediately alighted, embraced him, and with tears of joy asked him, "If he was not Signior Francis Frescobald, a Florentine merchant?" "Yes, Sir (said he) and your most humble servant." "My servant! (said the chancellor) No; you are my special friend, that relieved me

Gratitude. in my wants, laid the foundation of my greatness, and, as such, I receive you; and, since the affairs of my sovereign will not now permit a longer conference, I beg you will oblige me this day with your company at my house to dinner with me." Signior Frescobald was surprised and astonished with admiration who this great man should be that acknowledged such obligations, and so passionately expressed a kindness for him; but, contemplating a while his voice, his mien, and carriage, he concludes it to be Cromwell, whom he had relieved at Florence; and therefore not a little overjoyed, goes to his house, and attended his coming. His lordship came soon after; and immediately taking his friend by the hand, turns to the lord high admiral and other noblemen in his company, saying, "Don't your lordships wonder that I am so glad to see this gentleman? This is he who first contributed to my advancement." He then told them the whole story; and holding him still by the hand, led him into the dining-room, and placed him next himself at table. The company being gone, the chancellor made use of this opportunity to know what affair had brought him into England. Frescobald in few words gave him the true state of his circumstances: To which Cromwell replied, "I am sorry for your misfortunes, and I will make them as easy to you as I can; but, because men ought to be just before they are kind, it is fit I should repay the debt I owe you." Then leading him into his closet, he locked the door; and opening a coffer, first took out 16 ducats, delivering them to Frescobald, and said, "My friend, here is the money you lent me at Florence, with ten pieces you laid out for my apparel, and ten more you laid out for my horse; but, considering you are a merchant, and might have made some advantage of this money in the way of trade, take these four bags, in every one of which is 400 ducats, and enjoy them as the free gift of your friend." These the modesty of Frescobald would have refused, but the other forced them upon him. He next caused him to give him the names of all his debtors, and the sums they owed: which account he transmitted to one of his servants, with a charge to find out the men, and oblige them to pay him in 15 days under the penalty of his displeasure; and the servant so well discharged his duty, that in a short time the entire sum was paid. All this time Signior Frescobald lodged in the chancellor's house, where he was entertained according to his merits, with repeated persuasions for his continuance in England, and an offer of the loan of 60,000 ducats for four years if he would trade here: but he desired to return to Florence, which he did, with extraordinary favours from the lord Cromwell.

There is a species of grateful remorse, which sometimes has been known to operate forcibly on the minds of the most hardened in impudence. Of this Mr Andrews, who makes the remark, gives an instance in the following anecdote, said to have been a favourite one with the late Dr Campbell. "Towards the beginning of this century, an actor, celebrated for mimicry, was to have been employed by a comic author, to take off the person, the manner, and the singularly awkward delivery of the celebrated Dr Woodward, who was intended to be introduced on the stage in a laughable character, (viz. in that of *Dr Fossile*, in *Three Hours after Marriage*). The mimic dressed himself as a coun-

try man, and waited on the doctor with a long catalogue of ailments, which he said attended on his wife. The physician heard with amazement diseases and pains of the most opposite nature, repeated and redoubled on the wretched patient. For, since the actor's greatest wish was to keep Dr Woodward in his company as long as possible, that he might make the more observations on his gestures, he loaded his poor imaginary spouse with every infirmity which had any probable chance of prolonging the interview. At length, being become completely master of his errand, he drew from his purse a guinea, and, with a scrape, made an uncouth offer of it. 'Put up thy money, poor fellow (cried the doctor); thou hast need of all thy cash and all thy patience too, with such a bundle of diseases tied to thy back.' The actor returned to his employer, and recounted the whole conversation, with such true feeling of the physician's character, that the author screamed with approbation. His raptures were soon checked; for the mimic told him, with the emphasis of sensibility, that he would sooner die than prostitute his talents to the rendering such genuine humanity a public laughing-stock. The player's name was *Griffin*.

GRATZ, a strong town of Germany, and capital of Styria, with a castle seated on a rock, and an university. The Jesuits had a college here; and there are a great number of handsome palaces, and a fine arsenal. The castle stands upon a very lofty hill, and communicates with the river by means of a deep well. The empress dowager was obliged to retire hither during the war of 1741 and 1742. It is seated on the river Muer, in E. Long. 15. 16. N. Lat. 47. 10.

GRATIUS, a Latin poet, contemporary with Ovid, the author of a poem entitled *Cynegeticon*, or the *Manner of hunting with dogs*; the best edition of which is that of Leyden, 12mo, with the learned notes of Janus Ulitius.

GRAVE, in *Grammar*, a species of accent opposite to acute. The grave accent is expressed thus (`); and shows that the voice is to be depressed, and the syllable over which it is placed pronounced in a low deep tone.

GRAVE, in *Music*, is applied to a sound which is in a low or deep tone. The thicker the chord or string, the more grave the tone or note, and the smaller the acuter. Notes are supposed to be the more grave in proportion as the vibrations of the chord are less quick.

GRAVE, in the Italian music, serves to denote the slowest movement.

GRAVE, is also used for a tomb, wherein a person defunct is interred.

Graves, among the Jews, were generally out of the city, though we meet with instances of their interring the dead in towns. Frequent mention is made of graves upon mountains, in highways, in gardens, and private houses. So that nothing on this head seems to have been determined. The same may be observed with respect to the Greeks. The Thebans had a law that every person who built a house should provide a burial ground. Men who had distinguished themselves were frequently buried in the public forum. The most general custom was, however, to bury out of the city, chiefly by the highway side. The Romans were forbidden by the law of the 12 tables to bury or burn the

Gratitude
||
Grave.

Grave
Grave-
sande.

the dead in the city; but some we find had their sepulchres in Rome, though they paid a fine for the indulgence.

GRAVE, a very strong town of the Netherlands, in Dutch Brabant, seated on the river Maese, beyond which there is a fort. E. Long. 5. 41. N. Lat. 51. 46.

GRAVEL, in *Natural History and Gardening*, a congeries of pebbles, which, mixed with a stiff loam, makes lasting and elegant gravel-walks; an ornament peculiar to our gardens, and which gives them an advantage over those of other nations.

GRAVEL. See *MEDICINE Index*.

GRAVEL-Walks. To make these properly, the bottom should be laid with lime-rubbish, large flint-stones, or any other hard matter, for eight or ten inches thick, to keep weeds from growing through, and over this the gravel is to be laid six or eight inches thick. This should be laid rounding up in the middle, by which means the larger stones will run off to the sides, and may be raked away; for the gravel should never be screened before it is laid on. It is a common mistake to lay these walks too round, which not only makes them uneasy to walk upon, but takes off from their apparent breadth. One inch in five feet is a sufficient proportion for the rise in the middle; so that a walk of 20 feet wide should be four inches higher at the middle than at the edges, and so in proportion. As soon as the gravel is laid, it should be raked, and the large stones thrown back again: then the whole should be rolled both lengthwise and crosswise; and the person who draws the roller should wear shoes with flat heels, that he may make no holes; because holes made in a new walk are not easily remedied. The walks should always be rolled three or four times in very hard showers, after which they will bind more firmly than otherwise they could ever be made to do.

Gravel with some loam among it, binds more firmly than the rawer kinds; and when gravel is naturally very harsh and sharp, it is proper to add a mixture of loam to it. The best gravel for walks is such as abounds with smooth round pebbles, which, being mixed with a little loam, are bound so firmly together, that they are never afterwards injured either by wet or dry weather. These are not so liable to be turned up by the feet in walking, as the more irregularly shaped pebbles, and remain much more firmly in their places after rolling.

GRAVELINES, a strong sea-port town of the Netherlands, in Flanders, with a castle and harbour, seated in a marshy country on the river Aa, near the sea, in E. Long. 2. N. Lat. 50. 59.

GRAVELLY LAND or **SOIL**, that abounding with gravel or sand, which easily admits of heat and moisture; and the more stony such lands are, the more barren they prove.

GRAVENAC, a town of Germany, in the circle of Suabia, and capital of a county of the same name. E. Long. 8. 15. N. Lat. 48. 22.

GRAVER, in the art of engraving, a tool by which all the lines, scratches, and shades, are cut in copper, &c. See *ENGRAVING*.

GRAVESANDE, **WILLIAM JAMES**, was born of an ancient and honourable family at Delft in Holland, in 1688. He studied the civil law at Leyden, but

mathematical learning was his favourite amusement. When he had taken his doctor's degree in 1707, he settled at the Hague, and practised at the bar, in which situation he cultivated an acquaintance with learned men; with a society of whom, he published a periodical review entitled *Le Journal Litteraire*, which was continued without interruption from the year 1713 to the year 1722, when he died. The most considerable of his works are, "A treatise on perspective; An introduction to the Newtonian philosophy, or a treatise on the elements of physics confirmed by experiments; A treatise on the elements of algebra, for the use of young students;" and "A course of logic and metaphysics." He had intended to have presented the public with a system of morality, but his death prevented the execution. The ministers of the republic consulted him on all occasions wherein his talents were requisite; and his skill in calculation was often of service to them; as was his address in deciphering, for detecting the secret correspondence of their enemies. As professor of mathematics and astronomy at Leyden, none ever applied the powers of nature with more success, or to more useful purposes.

GRAVESEND, a town of Kent in England, situated on the banks of the Thames. It is 25 miles from London; and has a blockhouse well mounted with cannon, to command the ships and river, directly opposite to Tilbury fort in Essex. The town was plundered and burnt by the French and Spaniards in the reign of Richard II. to compensate which, the king, at the request of the abbot of St Mary-le-Grace of Tower-hill, to whom he had granted a manor there called *Parrocks*, vested it and Milton with the sole privilege of carrying passengers by water from hence to London at 4s. the whole fare, or 2d. a-head; which was confirmed by Henry VIII.; but now the fare is 9d. a-head in the tilt-boat, and 1s. in the wherry. The former must not take in above forty passengers, the latter no more than eight. Coaches ply here at the landing of people from London, &c. to carry them to Rochester. This town and Milton were incorporated by Queen Elizabeth by the name of the *portreeve*, (now the mayor), jurats, and inhabitants of Gravesend and Milton: And as Gravesend is the place where most passengers through Kent from foreign parts take boat for London, that queen, in order to show the grandeur of the metropolis of her kingdom, ordered the lord mayor, aldermen, and city companies, to receive all ambassadors and eminent strangers here in their formalities, and to attend them to London in barges if by water; or if they chose to come by land, they were to meet them on horseback on Blackheath in their livery gowns. The towns for several miles round are supplied from hence with garden stuffs; of which great quantities are also sent to London, where the asparagus of Gravesend is preferred to that of Battersea. All outward-bound ships are obliged to anchor in this road till they have been visited by the customhouse officers; and for this purpose a centinel at the blockhouse fires a musket: but the homeward-bound all pass by without notice, unless it be to put waiters on board, if they are not supplied before. As the outward-bound generally take in provisions here, the place is full of seamen, who are all in a hurry. The whole town being burn down in 1727, 5000l.

Grave-
sande,
Gravesend.

Gravesend was granted by parliament in 1731 for rebuilding its church, as one of the 50 new ones. In 1624, one Mr Pinnock gave 21 dwelling-houses here, besides one for a master weaver, to employ the poor; and here is a charity-school for 24 boys. Population 3119 in 1811. E. Long. 0. 22. N. Lat. 51. 27.

GRAVINA, a town of Italy, in the kingdom of Naples, and Terra di Bari, with a bishop's see, and the title of a duchy. E. Long. 17. N. Lat. 41.

GRAVINA'S ISLANDS, a range of islands in the North Pacific ocean, 40 miles in length. E. Long. 228. 24. N. Lat. 54. 52.

GRAVITATION, in *Natural Philosophy*, is sometimes distinguished from *gravity*. Thus M. Maupertuis takes gravity for that force whereby a body would fall to the earth; but gravitation for the same diminished by the centrifugal force. See *NEWTONIAN Philosophy*.

GRAVITY, or **GRAVITATION** (for the words are most commonly used synonymously), signifies either the force by which bodies are pressed towards the surface of the earth, or the manifest effect of that force; in which last sense the word has the same signification with *weight* or *heaviness*.

Concerning gravity in the first sense of the word, or that active power by which all bodies are impelled towards the earth, there have been great disputes. Many eminent philosophers, and among the rest Sir Isaac Newton himself, have considered it as the first of all second causes; an incorporeal or spiritual substance, which never can be perceived any other way than by its effects; an universal property of matter, &c. Others have attempted to explain the phenomena of gravitation by the action of a very subtle ethereal fluid; and to this explanation Sir Isaac, in the latter part of his life, seems not to have been averse. He hath even given a conjecture concerning the manner in which this fluid might occasion these phenomena. But for a full account of the discoveries of this great philosopher concerning the laws of gravitation, the conjectures made by him and others concerning its cause, the various objections that have been made to his doctrine, and the state of the dispute at present, see the articles *NEWTONIAN Philosophy* and *ASTRONOMY*.

Specific Gravity denotes the weight belonging to an equal bulk of every different substance. Thus the exact weight of a cubic inch of gold, compared with a cubic inch of water, tin, lead, &c. is called its *specific gravity*. See *HYDRODYNAMICS*, and *SPECIFIC Gravity*.

GRAY, or **GREY**, a mixed colour partaking of the two extremes, black and white. See *DYEING Index*.

In the manege they make several sorts of grays; as the branded or blackened gray, which has spots quite black dispersed here and there. The dappled gray, which has spots of a darker colour than the rest of the body. The light or silver gray, wherein there is but a small mixture of black hairs. The sad or iron gray, which has but a small mixture of white. And the brownish or sandy-coloured gray, where there are bay-coloured hairs mixed with the black.

GRAY, a town of France, in the department of Upper Saone, and capital of the bailiwick of Amont. It is a trading place, and seated on the river Saone, in E. Long. 53. 40. N. Lat. 47. 30.

GRAY, Lady Jane. See **GREY**.

VOL. X. Part I.

†

GRAY, Thomas, an admired English poet, was the youngest and only surviving son of a reputable citizen of London, and was born in Cornhill in 1716. He was educated at Eton, where he contracted a friendship with Mr Horace Walpole, and with Mr Richard West son of the lord chancellor of Ireland. Mr West and Mr Gray were both intended for the bar: but the former died early in life, and the latter was diverted from that pursuit by an invitation to accompany Mr Walpole in his travels; which he accepted without any determined plan for his future life. During Mr Gray's travels, he wrote a variety of letters to Mr West and to his parents, which are printed with his poems; and when he returned, finding himself in narrow circumstances, yet with a mind indisposed for active employment, he retired to Cambridge, and devoted himself to study. Soon after his return, his friend West died; and the melancholy impressed on him by this event may be traced in his admired "Elegy written in a country churchyard;" which is thought to have been begun, if not finished, at this time; though the conclusion, as it stands at present, is certainly different from what it was in the first manuscript copy. The first impulse of his sorrow for the death of his friend gave birth to a very tender sonnet in English, on the Petrarchian model; and also to a sublime apostrophe in hexameters, written in the genuine strain of classical majesty, with which he intended to begin one of his books *De Principiis Cogitandi*.

From the winter of the year 1742, to the day of his death, his principal residence was at Cambridge; from which he was seldom absent any considerable time, except between the years 1759 and 1762; when on the opening of the British Museum, he took lodgings in Southampton-row, in order to have recourse to the Harleian and other manuscripts there deposited, from which he made several curious extracts, amounting in all to a tolerable sized folio, at present in the hands of Mr Walpole.

About the year 1747, Mr Mason, the editor of Mr Gray's poems, was introduced to him. The former had written, a year or two before, some imitations of Milton's juvenile poems, viz. A Monody on the Death of Mr Pope, and two pieces entitled *Il Bellicoso* and *Il Pacifico* on the peace of Aix la-Chapelle; and the latter revised them at the request of a friend. This laid the foundation of an intimacy which continued without interruption to the death of Mr Gray.

About the year 1750, Mr Gray had put his last hand to his celebrated Elegy written in a country churchyard, and had communicated it to his friend Mr Walpole, whose good taste was too much charmed with it to suffer him to withhold the sight of it from his acquaintance. Accordingly it was shown about for some time in manuscript, and received with all the applause it so justly merited. At last the publisher of one of the magazines having obtained a surreptitious copy of it, Mr Gray wrote to Mr Walpole, desiring that he would put his own manuscript into the hands of Mr Dodsley, and order him to print it immediately. This was the most popular of all our author's publications. It ran through 11 editions in a very short space of time; was finely translated into Latin by Messrs Ansty and Roberts; and in the same year by Mr Lloyd.

From July 1759 to the year 1762, he generally re-

L

sided

Gray.

sided in London, with a view, as we have already observed, of having recourse to the British Museum. In July 1786, his grace the duke of Grafton wrote him a polite letter, informing him, that his majesty had been pleased to offer to him the professorship of Modern History in the university of Cambridge, then vacant by the death of Mr Laurence Brocket. This place was valuable in itself, the salary being 400l. a year; but what rendered it particularly acceptable to Mr Gray was its being given him without any solicitation. He was indeed remarkably disinterested in all his pursuits. Though his income, before this addition, was very small, he never read or wrote with a view of making his labours useful to himself. He may be said to have been of those few personages in the annals of literature, especially in the poetical class, who are devoid of self-interest, and at the same time attentive to economy; and also was among mankind in general one of those very few economists, who possess that talent, untingered with the slightest stain of avarice. When his circumstances were at the lowest, he gave away such sums in private charity, as would have done credit to an ampler purse. But what chiefly deterred him from seeking any advantage by his literary pursuits, was a certain degree of pride, which led him to despise the idea of being thought an author by profession.

However, it is probable, that early in life he had an intention of publishing an edition of Strabo; for his papers contain a great number of notes and geographical disquisitions on that author, particularly with respect to that part of Asia which comprehends Persia and India. The indefatigable pains which he took with the writings of Plato, and the quantity of critical as well as explanatory observations which he has left upon almost every part of his works, plainly indicate, that no man in Europe was better prepared to republish and illustrate that philosopher than Mr Gray. Another work, on which he bestowed uncommon labour was the *Anthologia*. In an interleaved copy of that collection of Greek epigrams, he has transcribed several additional ones, which he selected in his extensive reading; has inserted a great number of critical notes and emendations, and subjoined a copious index. But whether he intended this performance for the press or not, is uncertain. The only work which he meditated upon with this direct view from the beginning was a history of English poetry, upon a plan sketched out by Mr Pope. He has mentioned this himself in an advertisement to those three fine imitations of Norse and Welsh poetry, which he gave the world in the last edition of his poems. But after he had made some considerable preparations for the execution of this design, and Mr Mason had offered him his assistance, he was informed, that Mr Wharton, of Trinity College, Oxford, was engaged in a work of the same kind. The undertaking was therefore relinquished, by mutual consent; and soon after, on that gentleman's desiring a sight of the plan, our author readily sent him a copy of it.

Among other sciences, Mr Gray had acquired a great knowledge of Gothic architecture. He had seen and accurately studied in his youth, while abroad, the Roman proportions on the spot, both in ancient times, and in the works of Palladio. In his later years he

Gray.

applied himself to consider those stupendous structures of more modern date that adorn our own country; which, if they have not the same grace, have undoubtedly equal dignity. He endeavoured to trace this mode of building from the time it commenced through its various changes, till it arrived at its perfection in the reign of Henry VIII. and ended in that of Elizabeth. For this purpose, he did not so much depend upon written accounts, as that internal evidence which the buildings themselves give of their respective antiquity; since they constantly furnish to the well-informed eye, arms, ornaments, and other marks, by which their several ages may be ascertained. On this account he applied himself to the study of heraldry as a preparatory science; and has left behind him a number of genealogical papers, more than sufficient to prove him a complete master of it. By these means he arrived at so very extraordinary a pitch of sagacity, as to be enabled to pronounce, at first sight, on the precise time when every particular part of any of our cathedrals was erected. But the favourite study of Mr Gray for the last ten years of his life was natural history, which he then rather resumed than began; as by the instructions of his uncle Antrobus, he was a considerable botanist at 15. The marginal notes which he has left on Linnæus and other writers on the vegetable, animal, and fossil kingdoms, are very numerous: but the most considerable are on Hudson's *Flora Anglica*, and the tenth edition of the *Systema Naturæ*; which latter he interleaved and filled almost entirely. While employed on zoology, he read Aristotle's treatise on that subject with great care, and explained many difficult passages of that obscure ancient by the lights he had received from modern naturalists. In a word, excepting pure mathematics, and the studies dependent on that science, there was hardly any part of human learning in which he had not acquired a competent skill, and in most of them a consummate mastery. To this account of his literary character we may add, that he had a fine taste in painting, prints, gardening, and music; and was moreover a man of good breeding, virtue, and humanity.

He died in 1771: and an edition of his poems, with memoirs of his life and writings, were published in 4to, in 1775, by Mr Mason. This gentleman, however, instead of employing his own pen in drawing Mr Gray's character, has adopted one drawn by the reverend Mr Temple, rector of Mashfield in Devonshire, in a letter to Mr Boswell; to whom the public are indebted for communicating it. "Perhaps (says Mr Temple) he was the most learned man in Europe. He was equally acquainted with the elegant and profound parts of science, and that not superficially but thoroughly. He knew every branch of history, both natural and civil; had read all the original historians of England, France, and Italy: and was a great antiquarian. Criticism, metaphysics, morals, politics, made a principal part of his plan of study; voyages and travels of all sorts were his favourite amusement; and he had a fine taste in painting, prints, architecture, and gardening. With such a fund of knowledge, his conversation must have been equally instructing and entertaining; but he was also a good man, a well-bred man, a man of virtue and humanity. There is no character without some speck, some imperfection; and I think the greatest defect in his

Gray
||
Greaves.

his was an affectation in delicacy, or rather effeminacy, and a visible fastidiousness, or contempt and disdain of his inferiors in science. He also had, in some degree, that weakness which disgusted Voltaire so much in Mr Congreve: though he seemed to value others chiefly according to the progress they had made in knowledge, yet he could not bear to be considered himself merely as a man of letters; and though without birth, or fortune, or station, his desire was to be looked upon as a private independent gentleman, who read for his amusement. Perhaps it may be said, What signifies so much knowledge, when it produces so little? Is it worth taking so much pains to leave no memorial but a few poems? But let it be considered, that Mr Gray was, to others, at least innocently employed; to himself, certainly beneficially. His time passed agreeably; he was every day making some new acquisition in science; his mind was enlarged, his heart softened, and his virtues strengthened; the world and mankind were shown to him without a mask; and he was taught to consider every thing as trifling, and unworthy the attention of a wise man, except the pursuit of knowledge, and the practice of virtue in that state wherein God hath plac'd us."

GRAYLING. See SALMO, ICHTHOLOGY *Index*.

In angling for this fish the hook must be armed upon the shanks with a very narrow plate of lead, which should be slenderest at the bent of the hook, that the bait (which is to be a large grasshopper, the uppermost wing of which must be pulled off) may come over to it the more easily. At the point let there be a cod-bait in a continual motion. The jag-tail, which is a worm of a pale flesh-colour, with a yellow tag on its tail, is an excellent bait for the grayling in March and April.

GREASE, a swelling and gourdianness of the legs of a horse. See FARRIERY, N^o 482.

GREAT, a term of comparison, denoting a thing to have more extension than some other to which it is referred. Thus we say, a *great* space, a *great* distance, a *great* figure, a *great* body, &c.

GREAT is likewise used figuratively in matters of morality, &c. to signify ample, noble, elevated, extraordinary, important, &c. Thus we say, Shakespeare was a *great* genius, Da Vinci a *great* painter, Galileo a *great* philosopher, Bossu a *great* critic, &c.

GREAT is also a title or quality appropriated to certain princes and other illustrious personages. Thus we say, the *great* Turk, the *great* Mogul, the *great* chám of Tartary, the *great* duke of Florence, &c.

GREAT is also a surname bestowed on several kings and emperors. Thus we say, Alexander the *great*; Cyrus the *great*; Charles the *great*, or Charlemagne; Henry the *great* of France, &c.

GREAT is also applied to several officers who have pre-eminence over others. Thus we say, the lord *great* chamberlain; the *great* marshal of Poland, &c.

GREATER TONE, in *Music*. See TONE.

GREAVES, JOHN, an eminent physician and antiquary, was the eldest son of John Greaves sector of Cotswold, near Alresford in Hampshire, and born in 1602. He was educated at Balliol College in Oxford, from which he removed to Merton. He was afterwards, on the foot of his great merit, chosen geometry professor of Gresham college. His ardent thirst

of knowledge soon carried him into several parts of Europe, where he eagerly seized every opportunity of improving it. His next voyage was into the eastern countries; where nothing remarkable in the heavens, earth, or even subterraneous places, seems to have escaped his nice observation. He, with indefatigable industry, and even at the peril of his life, collected a considerable number of Arabic, Persian, and Greek manuscripts, for Archbishop Lang. Of these he well knew the value, as he was a master of the languages in which they were written. He also collected for that prelate many oriental gems and coins. He took a more accurate survey of the pyramids than any traveller who went before him. On his return from the East, he visited several parts of Italy a second time. During his stay at Rome, he made a particular inquiry into the true state of the ancient weights and measures. Soon after he had finished his second voyage, he was chosen Savilian professor of astronomy at Oxford. He was eminently qualified for this professorship, as the works of ancient and modern astronomers were familiar to him. His books relating to oriental learning, his *Pyramidographia*, or a description of the pyramids in Egypt, his *Epochæ Celebriores*, and other curious and useful pieces, of which Mr Ward has given us a catalogue, show him to have been a great man. Those which he intended to publish would have shown him to be a greater; but he was stopped in his great career by death in 1652.

GREBE. See COLYMBUS, ORNITHOLOGY *Index*.

GREECE, the present Romelia, and in many respects one of the most deservedly celebrated countries in the world, was anciently bounded on the north by Mount Rhodope and the river Strymon; on the west by the Ionian sea; on the south by the Mediterranean; on the east by the Egean sea and Archipelago. It extended from Mount Rhodope and Orbelus to the promontory of Tenarus, the southmost point of Peloponnesus, now the Morea, about 450 English miles; in breadth from east to west about 235 miles, and it embraced an area of about 57,750 square miles.

The general names by which the inhabitants of this country were known to the ancients were those of *Graioi*, or *Graicoi*, from whence the name of *Greecs* is plainly derived. These names are thought to come from Græcia, the father, or (according to some) the son, of Thessalus, who gave name to Thessaly; but some modern critics choose to derive it from *Regon*, the same with *Rex*, the son of Peleg, by the transposition of a letter to soften the sound.—These names were afterwards changed for *Achai* and *Hellenes*; the first, as is supposed from *Achæus*, the son of Xuthus, the son of Hellen, and father of Ion; or, according to the fable, the son of Jupiter: the other from Hellen, above mentioned, the son of Deucalion, and father of Dorus, from whom came the *Doræ*, afterwards a famous nation among the Greeks. Another name by which the Greeks were known in some parts of the country, was that of *Pelagii*, which the Arcadians, the most ancient people in Greece, deduced from their pretended founder *Pelagus*, who is said to have got such footing in Peloponnesus, that the whole peninsula from him was called *Pelagion*. But the most ancient name of all is universally allowed to have been that of *Ionæ*, which the Greeks themselves derived from Ion the son of

L 3

Xuthus;

Greaves
||
Greec.

Greece. Xuthus; or, as the fable hath it, of Apollo, by Creusa the daughter of Erichtheus the grandson of Deucalion. Josephus, however, affirms, that their original is of much older date; and that Javan, the son of Japhet, and grandson of Noah, was the first who peopled these countries; which Bochart hath also rendered very probable. It is true, indeed, that among the Greeks themselves, only the Athenians, and such colonies as sprung from them, were called *Iones*: but it is also plain beyond exception, that other nations gave this name to all the inhabitants of Greece.

The inhabitants of Greece in the first ages, even by the confession of their own historians, appear to have been savages scarce a degree removed from brutes. They lived indifferently on every fruit, herb, or root that came in their way: and lay either in the open fields, or at best sheltered themselves in dens, caves, and hollow trees: the country itself in the mean time remaining one continued uncultivated desert. The first improvement they made in their way of living, was the exchanging of their old food for the more wholesome acorns, building huts for themselves to sleep in, and covering their bodies with the skins of beasts. For all this, it seems, they were beholden to Pelagus above mentioned (supposed by some to be Peleg spoken of in Scripture), and who was highly revered by them on that account.—This reformation in their way of life, however, it seems, wrought none in their manners. On the contrary, they who had nothing to fight for but a hole to sleep in, began now to envy and rob one another of these slender acquisitions. This, in process of time, put them under a necessity of joining themselves into companies under some head, that they might either more safely plunder their neighbours, or preserve what they had got. Laws they had none, except that of the sword: so that those only lived in safety who inhabited the most barren and craggy places; and hence Greece for a long time had no settled inhabitants, the weakest being always turned out by the strongest. Their gigantic size and strength, if we may believe Plutarch, added so much to their insolence and cruelty, that they seemed to glory in committing the greatest acts of violence and barbarity on those that unhappily fell into their hands.

The next advance towards civilization, was their forming themselves into regular societies, to cultivate the lands, and build themselves towns and cities for their safety. Their original barbarity and mutual violences against each other naturally prevented them from uniting as one nation, or even into any considerable community: and hence the great number of states into which Greece was originally divided. The most remarkable of these small principalities mentioned in history are the following: In Peloponnesus were those of Sicyon, Argos, and Messenia, Achaia Propria, Arcadia, and Laconia. In Græcia Propria, (that part of Greece which lay without Peloponnesus,) were those of Attica, Megara, Bœotia, Lucris, Epichnemidia, Doris, Phocis, Locris, Ozolæa, and Ætolia. In Epirus were the Molossi, Amphiloichi, Cassiopaeci, Dræopes, Chaoces, Theaprotii, Almeni, and Acarnani. In Thessaly were those of Thessaliotis, Estiotis, Pelasgiotis, Magnesia and Phthia.—All these have at one time or other been severally governed by kings of their own, though we only find the names of

many of them mentioned in the histories of the more considerable kingdoms of Sparta, Attica, Thebes, &c.—The erection of these kingdoms, however, for some time, did not much alter the case; the inhabitants of the new kingdoms plundered and destroyed one another without mercy. Attica was the only place in any degree free from these incursions, because it was naturally destitute of every thing that could invite a plundering enemy; but those cities fared much worse which were situated on the sea-coasts; because they were in continual danger of being plundered either by sea or land: for pirates at that time did not less infest all those seas than robbers did the land. And this was one main cause why most of the ancient cities of Greece were situated at some considerable distance from the shore; but even in these, as all their safety consisted in the resistance they could make against an invader, their inhabitants were under the necessity of going constantly armed, and being ever on their guard.

Another mischief arising from these continual piracies and robberies was, that they occasioned the far greater part of the lands to lie uncultivated, so that the people only planted and sowed as much as was barely necessary for their present support; and where there was such an universal neglect of agriculture, there could be as little room for any discoveries in other useful arts and trades. Hence, when other nations, as the Jews, Egyptians, Midianites, Phœnicians, &c. had improved themselves to a very high degree, the Greeks seem to have been utter strangers to every useful art.

During this period of savage barbarity, the most renowned Grecian heroes; as Hercules, Theseus, &c. performed their exploits; which, however exaggerated by poetic fiction, no doubt had a foundation in truth. Some indeed are of opinion that the Grecian heroes are entirely fictitious, and their exploits derived from those of the Hebrew worthies, such as Samson, Gideon, &c. Yet, considering the extreme degree of barbarity which at that time prevailed throughout Greece, it seems not at all improbable that some persons of extraordinary strength and courage might undertake the cause of the oppressed, and travel about like the more modern knights-errant in quest of adventures.

The first expedition in which we find the Greeks united, was that against Troy, the particulars of which are recited under the article TROY. Their success here (which happened about 1184 B. C.) cost them very dear; vast numbers of their bravest warriors being slain; great numbers of the survivors being cast away in their return; and many of those who had the good luck to get back again being soon after murdered, or driven out of their country. It is probable, however, that their having staid for such a long time in Asia, might contribute to civilize the Greeks somewhat sooner than what they otherwise would have been; and accordingly, from this time, we find their history somewhat less obscure, and as it were beginning to emerge out of darkness. The continual wars, indeed, in which they were engaged among themselves, no doubt, for a long time, prevented them from making any considerable advances in those arts in which they afterwards made so great progress. These wars, which

Greece.

Greece.

which indeed never ceased as long as the Greeks preserved their liberty, rendered them brave, and skilled in the military art above all other nations; but at the same time they effectually prevented them from making permanent conquests, and confined them within the bounds of their own country; while the different states were one way or other so equally balanced, that scarce one of them was able perfectly to subdue another. The Spartans, however, having with great difficulty, reduced the kingdom of Messene, and added its territories to their own, became the leading people in Greece. Their superiority was long disputed by Athens; but the Peloponnesian war at last determined that point in favour of the Spartans, when the city of Athens was taken, and its walls demolished by Lysander the Spartan general. See ATTICA, N^o 164. —By the battle of Leuctra, the Spartans lost that superiority which they had maintained for 500 years, and which now devolved on the Thebans. After the death of Epaminondas, the celebrated Theban general, however, as no person was found possessed of his abilities, the Thebans were again obliged to yield the superiority to the Spartans. But by this time the Greeks had become acquainted with the luxuries and elegancies of life; and all the rigour of their original laws could not prevent them from valuing these as highly as other people. This did not indeed abate their valour, but it heightened their mutual animosities, at the same time that, for the sake of a more easy and comfortable life, they became more disposed to submit to a master. The Persians, whose power they had long dreaded, and who were unable to resist them by force of arms, at last found out (by the advice of Alcibiades) the proper method of reducing the Grecian power; namely, by assisting them by turns, and supplying one state with money to fight against another till they should be all so much reduced, that they might become an easy prey. Thus the Greeks were weakened, though the Persians did not reap any benefit from their weakness. Philip of Macedon entered into the same political views; and partly by intrigue, partly by force, got himself declared generalissimo of Greece. His successor Alexander the Great completed their subjection; and by destroying the city of Thebes, and exterminating its inhabitants, struck such a terror throughout Greece, that he was as fully obeyed by all the states as by any of the rest of his subjects. During his absence in Persia, however, they attempted to shake off the Macedonian yoke, but were quelled by his general Antipater. The news of Alexander's death was to them a matter of the utmost joy; but their mutual animosities prevented them from joining in any solid plan for the recovery of their liberties, and hence they continued to be oppressed by Alexander's successors, or other tyrants, till Aratus, an Achæan, about 268 B. C. formed a design of setting his country free from these oppressors. He persuaded a number of the small republics to enter into a league for their own defence, which was called the *Achæan league*; and notwithstanding that the republics, taken singly, had very little strength, they not only maintained their independency, but soon became formidable when united. This association continued to become daily more and more powerful; but received a severe check from Cleomenes, king of Sparta, which

Greece.

obliged them to call in Antigonus to their assistance. This prince overcame Cleomenes, at the battle of Sellasia, and afterwards made himself master of Sparta. Thus he became a more formidable enemy than the one he had conquered, and the recovery of the Grecian liberties was incomplete.

Soon after this, the Greeks began to feel the weight of a power more formidable than any which they had yet experienced; namely, that of the Romans. That insidious and haughty republic first intermeddled with the Grecian affairs, under pretence of setting them at liberty from the oppression of Philip of Macedon. This, by a proper union among themselves, they might have accomplished: but in this they acted as though they had been infatuated; receiving with the utmost joy the decree of the Roman consul, who declared them free; without considering, that he who had thus given them liberty, might take it away at his pleasure. This lesson, however, they were soon taught, by the total reduction of their country to a Roman province; yet this scarce can be called a misfortune, when we look back to their history, and consider their outrages upon one another: nor can we sympathize with them for the loss of that liberty which they only made use of to fill their country with slaughter and bloodshed. After their conquest by the Romans, they made no united effort to recover their liberty. They continued in quiet subjection till the beginning of the 15th century. About that time they began to suffer under the tyranny of the Turks, and their sufferings were completed by the taking of Constantinople in 1453. Since that time they have groaned under the yoke of a most despotic government; so that all traces of their former valour, ingenuity, and learning, are now in a manner totally extinct.

Modern Greece comprehends Macedonia; Albania, now called *Arnaut*; Epirus; Thessaly, now *Jana*; Achaia, now *Livadia*; the Peloponnesus, now *Morea*; together with the islands on its coast, and in the Archipelago. The continent of Greece is seated betwixt the 36th and 43d degrees of north latitude; and between the 19th and 25th degrees of longitude, east of London. To the north, it is bounded by Bulgaria and Servia, from which it is divided by a ridge of mountains; to the south by the Mediterranean sea; to the east by Romania and the Archipelago; and to the west by the Adriatic or gulf of Venice. Its length is said to be about 450 miles, and its utmost breadth about 335 miles. The air is extremely temperate and healthy: and the soil fruitful, though badly cultivated; yielding corn, wine, delicious fruits, and abounding with cattle, fowls, and venison. As to religion, Christianity was planted in Greece soon after the death of our Saviour, and flourished there for many ages in great purity; but since the Greeks became subject to the Turkish yoke, they have sunk into the most deplorable ignorance, in consequence of the slavery and thralldom under which they groan, and their religion is now greatly corrupted. It is indeed little better than a heap of ridiculous ceremonies and absurdities. The head of the Greek church is the patriarch of Constantinople; who is chosen by the neighbouring archbishops and metropolitans, and confirmed by the emperor or grand vizir. He is a person of great dignity, being the head and director of the eastern church.

Greece. The other patriarchs are those of Jerusalem, Antioch, and Alexandria. Mr Tournefort tells us, that the patriarchates are now generally set to sale, and bestowed upon those who are the highest bidders. The patriarchs, metropolitans, archbishops, and bishops, are always chosen from among the Caloyers or Greek monks. Before the patriarchs receive their patents and the caftan, which is a vest of linsey-woolsey, or some other stuff, presented by the grand signior to ambassadors, and other persons newly invested with some considerable dignity, they are obliged to make large presents to the vizir, &c. The income of the patriarch of Constantinople is said to amount to no less than one hundred and twenty thousand guilders, of which he pays the one-half by way of annual tribute to the Ottoman Porte, adding six thousand guilders besides as a present at the feast of Bairam. The next person to a bishop among the clergy is an archimandrite, who is the director of one or more convents, which are called *mandren*; then come the abbot, the arch-priest, the priest, the deacon, the under-deacon, the chanter, and the lecturer. The secular clergy are subjected to no rules, and never rise higher than high-priest. They are allowed to marry once; but it must be with a virgin, and before they are ordained. They have neither glebe nor tythes, but depend upon the perquisites that arise from their office; and they seldom preach but in Lent. The Greeks have few nunneries; but a great many convents of monks, who are all priests, and, students excepted, obliged to follow some handicraft employment, and lead a very austere life. The Greeks deny the supremacy of the pope, and abhor the worship of images; but have a multitude of pictures of saints in their churches, whom they pray to as mediators. Their fasts are very severe. They believe also in the doctrine of transubstantiation, and that the Holy Ghost does not proceed from the Son. They admit not of purgatory, says Mr Thevenot: but yet they allow a third place, where they say the blessed remain, in expectation of the day of judgment. At mass they consecrate with leavened bread; and communicate under both kinds, as well laics as priests, and as well women and children as men. When they carry the sacrament to the sick, they do not prostrate themselves before it, nor expose it to be adored: neither do they carry it in procession, or have any particular feast in honour of it. Baptism is performed among them by plunging the whole body of the child thrice into water. Immediately after baptism, they give it confirmation and the communion; and seven days after that, it undergoes the ceremony of ablation. When a priest is married, among other ceremonies, the bridegroom and bride drink each two glasses of wine; then the glass is given to the priest, who merrily drinks off the rest of the wine, and breaking the glass, says, So may the bridegroom break the virginity of the bride. As to the character of the modern Greeks, they are said to be very covetous, hypocritical, treacherous, great pederasts, and at the same time revengeful to the highest degree; but very superstitious. They are so much despised by the Turks, that these do not value even a Greek who turns Mahometan. The Turks are remarkable for their taciturnity; they never use any unnecessary words; but the Greeks, on the contrary, are very talkative and

lively. The Turks generally practise what their religion enjoins, but the Greeks do not; and their misery puts them upon a thousand mean shifts and scandalous practices, authorised by bad example, and perpetuated from father to son. The Greek women have fine features and beautiful complexions: their countenances still very much resemble those of the ancient Greek statues. See GREECE, SUPPLEMENT.

GREEK, or GRECIAN, any thing belonging to ancient Greece.

The Greek language, as preserved in the writings of the celebrated authors of antiquity, as Homer, Hesiod, Demosthenes, Aristotle, Plato, Xenophon, &c. has a great variety of terms and expressions, suitable to the genius and occasions of a polite and learned people, who had a taste for arts and sciences. In it, proper names are significative; which is the reason that the modern languages borrow so many terms from it. When any new invention, instrument, machine, or the like, is discovered, recourse is generally had to the Greek for a name to it; the facility wherewith words are there compounded, affording such as will be expressive of its use: such are, barometer, hygrometer, microscope, telescope, thermometer, &c. But of all sciences, medicine most abounds with such terms; as diaphoretic, diagnosis, diarrhoea, hæmorrhagy, hydrophobia, phthisis, atrophy, &c. Besides the copiousness and significancy of the Greek, wherein it excels most, if not all, other languages, it has also three numbers, viz. a singular, dual, and plural: also abundance of tenses in its verbs, which makes a variety in discourse, prevents a certain dryness that always accompanies too great an uniformity, and renders that language peculiarly proper for all kinds of verse. The use of the participles, of the aorist and preterite, together with the compound words already mentioned, give it a peculiar force and brevity, without taking any thing from its perspicuity.

It is no easy matter to assign the precise difference between the modern and ancient Greek; which consists in the terminations of the nouns, pronouns, verbs, &c. not unlike what obtains between some of the dialects of the Italian or Spanish. There are also in the modern Greek many new words, not to be met with in the ancient. We may therefore distinguish three ages of the Greek tongue: the first of which ends at the time when Constantinople became the capital of the Roman empire; the second lasted from that period to the taking of Constantinople by the Turks; and the third from that time to this.

GREEK Bible. See BIBLE.

GREEK Church, is that part of the Christian church which is established in Greece; extending likewise to some other parts of Turkey. See GREECE.—It is thus called in Europe, Asia, and Africa, in contradistinction from the Latin or Romish church; as also the Eastern church, in distinction from the Western.

The Romanists call the Greek church the *Greek schism*; because the Greeks do not allow the authority of the pope, but depend wholly, as to matters of religion, on their own patriarchs. They have treated them as schismatics ever since the revolt, as they call it, of the patriarch Photius.

GREEK Monks and Nuns, of whatever order, consider St Basil as their founder and common father, and

esteem

Green-house.

esteem it the highest crime to deviate in the least from his constitutions. There are several beautiful convents with churches, in which the monks perform divine service day and night. Some of the monks are ecobites, or live together, wear the same habit, eat at the same table, and perform the same exercises and employments.

GREEK Orders, in Architecture, are the Doric, Ionic, and Corinthian; in contradistinction to the two Latin orders, the Tuscan and Composite. See **ORDER**.

GREEN, one of the original prismatic colours, exhibited by the refraction of the rays of light. See **CHROMATICS** and **COLOUR**.

GREEN, among painters and dyers. See **COLOUR-Making**, N° 27. and **DYEING**, N° 367.

GREEN-Cloth, a board or court of justice held in the counting-house of the king's household, composed of the lord steward and officers under him, who sit daily. To this court is committed the charge and oversight of the king's household in matters of justice and government, with a power to correct all offenders, and to maintain the peace of the verge, or jurisdiction of the court-royal; which is every way about 200 yards from the last gate of the palace where his majesty resides.

It takes its name, *board of green cloth*, from a green cloth spread over the board where they sit.

Without a warrant first obtained from this court, none of the king's servants can be arrested for debt.

Clarks of the GREEN Cloth were two officers of the board of green cloth, who appointed the diet of the king and his household; and kept all records, ledgers, and papers relating thereto; made up bills, parcels, and debentures for salaries, and provisions and necessaries for the officers of the buttery, pantry, cellar, &c. They also waited upon foreign princes when entertained by his majesty. But this has been lately abolished.

GREEN-Finch, the English name of the greenish fringilla, with the wings and tail variegated with yellow. See **FRINGILLA**; **ORNITHOLOGY Index**.

GREEN-House, or Conservatory, a house in a garden, contrived for sheltering and preserving the most curious and tender exotic plants, which in our climate will not bear to be exposed to the open air, especially during the winter season. These are generally large and beautiful structures, equally ornamental and useful.

The length of green-houses must be proportioned to the number of plants intended to be preserved in them, and cannot therefore be reduced to rule; but their depth should never be greater than their height in the clear; which, in small or middling houses, may be 16 or 18 feet, but in large ones from 20 to 24 feet; and the length of the windows should reach from about one foot and a half above the pavement, and within the same distance of the ceiling, which will admit of a cornice round the building over the heads of the windows. Their breadth cannot be in proportion to their length: for if in the largest buildings they are more than seven or seven feet and a half broad, they will be extremely heavy and inconvenient. The piers between the windows must be as narrow as may be to support the building; for which reason they should either be of stone or of hard burnt bricks. If the piers are made of stone, they should be 30 inches wide in front, and

Green-house.

stopped off behind to about 18 inches, by which means there will be no corners to take off the rays of the sun. If they are of brick, they will require to be at least three feet in front, but they should be in the same manner sloped off behind. Over the green-house may be rooms for drying and preserving seeds, roots, &c. and behind it a place for tools and other purposes; and both these behind, and the rooms above, will be of great use in keeping off the frosts, so that the wall between these need not be of more than two bricks and a half in thickness.

The floor of the green-house, which should be laid either with Bremen squares, Parbeck stone, or flat tiles, must be raised two feet above the surface of the adjoining ground, or if the situation be damp, at least three feet; and if the whole is arched with low brick arches under the floor, they will be of great service in preventing damps: and under the floor, about two feet from the front, it will be very advisable to make a flue of ten inches wide and two feet deep: this should be carried the whole length of the house, and then returned back along the hinder part, and there be carried up into funnels adjoining to the tool-house, by which the smoke may be carried off. The fire-place may be contrived at one end of the house, and the door at which the fuel is put in, as also the ash-grate, may be contrived to open into the tool-house, and the fuel being laid in the same place, the whole will be out of sight. Bradley advises, that the front of green-houses, in the colder parts of England, be built in a sweep or semicircle, so that one part or other of it may receive the sun's rays all day. The use of fires must, however, be very sparing in this place: and it is not one winter in three or four that will require them in any part, only when the weather is very severe, and the frost cannot well be kept out any other way, this is an expedient that is good to have in readiness, as it may save a whole house of plants. Within of the windows, in front of the green-house, there should be good strong shutters, made with hinges, to fold back close to the piers, that they may not obstruct the rays of the sun. The back part of the house should be either laid over with stucco or plastered with mortar, and whitewashed, in order to prevent the frosty air from penetrating through the walls. When the green-house is wainscotted, the walls should be plastered with lime and hair behind the wainscot, to keep out the cold; and the wainscot, as well as the ceiling, and every part within the house should be painted white, for the reflection of the sun's rays. There must be a number of tressels with forms of wood upon them, to support the pots and plants; the tallest to be placed hindmost, the lowest within four feet of the windows: and the rows of plants should rise gradually, so that the heads of the second row should be entirely above the first; and behind them there should be a space of at least five feet, for the conveniency of watering the plants, and for a free circulation of air. It has been observed that the placing of the euphorbium, tereuses, and other succulent plants among orange-trees, and other common green-house plants, is always destructive of them, by making them receive an improper sort of effluvia, which plants of that kind imbibe very freely. They should therefore be placed in two wings built

Green-house
Greenland.

built at each end of the green-house; which, if well contrived, will be a great beauty as well as use to the building. These wings may be made capable of a great warmth also by more flues, and may be made to contain a hot-bed of tanner's bark for the raising many of the tender plants, natives of warm climates.

Whilst the front of the green-house is exactly south, one of the wings may be made to face the south-east, and the other the south-west. By this disposition the heat of the sun is reflected from one part of the building to the other all day, and the front of the main green-house is guarded from the cold winds. These two wings may be so contrived as to maintain plants of different degrees of hardiness, which may be easily effected by the situation and extent of the fire-place, and the manner of conducting the flues: the wing facing the south-east is evidently the most proper for the warmest stove; this may be divided in the middle by a partition of glass, with glass-doors opening from one division to the other. In each of these there should be a fire-place, with flues carried up against the back-wall, through which the smoke should be made to pass as many times the length of the house as the height will admit of the number of flues; for the longer the smoke is in passing, the more heat will be given to the house with a less quantity of fuel. The other wing, facing the south-west, should be divided and furnished with flues in the same manner; and thus different degrees of heat may be obtained, according to the seasons and the particular sorts of plants that are to be preserved. If there are no sheds behind these wings, the walls should not be less than three bricks thick: and the back part, having sloping roofs, which are covered with tiles or slates, should be lined with reeds, &c. under the covering. The sloping glasses of these houses should be made to slide and take off, so that they may be drawn down more or less in warm weather to admit air to the plants; and the upright glasses in front may be so contrived as that every other may open as doors upon hinges, and the alternate glasses may be divided into two: the upper part of each should be so contrived as to be drawn down like sashes, so that either of them may be used to admit air in a greater or less quantity as there may be occasion.

As to the management of the plants in the green-house, Mortimer recommends the opening of the mould about them from time to time, and sprinkling a little fresh mould in them, and a little warm dung on that; as also to water them when the leaves begin to wither and curl, and not oftener, which would make them fade and be sickly; and to take off such leaves as wither and grow dry.

GREEN-Sickness. See CHLOROSIS, MEDICINE *Index.*

GREEN-Silver, the name of an ancient custom within the manor of Writtel in the county of Essex in England; which is, that every tenant whose fore-door opens to Greenbury, shall pay an halfpenny yearly to the lord, by the name of *green-silver.*

GREEN Wax, is used where estates are delivered to the sheriffs out of the exchequer, under the seal of that court, made in green wax, to be levied in the several counties. This word is mentioned the 43d stat. Ed. III. c. 9. and 7 Hen. IV. c. 7.

GREENLAND, a general name by which are denoted the most easterly parts of America, stretching to-

wards the north pole, and likewise some islands to the northward of the continent of Europe, lying in very high latitudes.

This country is divided into West and East Greenland.—West Greenland is now determined by our latest maps to be a part of the continent of America, though upon what authority is not very clear. That part of it which the Europeans have any knowledge of is bounded on the west by Baffin's bay, on the south by Davis's straits, and on the east by the northern part of the Atlantic ocean. It is a very mountainous country, and some parts of it so high that they may be discerned 30 leagues off at sea. The inland mountains, hills, and rocks, are covered with perpetual snow; but the low lands on the sea-side are clothed with verdure in the summer season. The coast abounds with inlets, bays, and large rivers; and is surrounded with a vast number of islands of different dimensions. In a great many places, however, on the eastern coast especially, the shore is inaccessible by reason of the floating mountains of ice. The principal river, called *Baal*, falls into the sea in the 64th degree of latitude, where the first Danish lodge was built in 1721; and has been navigated above 40 miles up the country.

West Greenland was first peopled by Europeans in the eighth century. At that time a company of Icelanders, headed by one Ericke Rande, were by accident driven on that coast. On his return he represented the country in such a favourable light, that some families again followed him thither, where they soon became a thriving colony, and bestowed on their new habitation the name of *Greenland* or *Greenland*, on account of its verdant appearance. This colony was converted to Christianity by a missionary from Norway, sent thither by the celebrated Olaf, the first Norwegian monarch who embraced the true religion. The Greenland settlement continued to increase and thrive under his protection; and in a little time the country was provided with many towns, churches, convents, bishops, &c. under the jurisdiction of the archbishop of Drontheim. A considerable commerce was carried on between Greenland and Norway; and a regular intercourse maintained between the two countries till the year 1406, when the last bishop was sent over. From that time all correspondence was cut off, and all knowledge of Greenland has been buried in oblivion.

This strange and abrupt cessation of all trade and intercourse has been attributed to various causes; but the most probable is the following: The colony, from its first settlement, had been harassed by the natives, a barbarous and savage people, agreeing in customs, garb, language, and appearance, with the Esquimaux found about Hudson's bay. This nation, called *Schrellings*, at length prevailed against the Iceland settlers who inhabited the western district, and exterminated them in the 14th century: insomuch, that when their brethren of the eastern district came to their assistance, they found nothing alive but some cattle and flocks of sheep running wild about the country. Perhaps they themselves afterwards experienced the same fate, and were totally destroyed by these *Schrellings*, whose descendants still inhabit the western parts of Greenland, and from tradition confirm this conjecture. They affirm that the houses and villages, whose ruins still appear, were inhabited by a nation of strangers, whom their ancestors

Greenland. ancestors destroyed. There are reasons, however, for believing that there may be still some descendants of the ancient Iceland colony remaining in the eastern district, though they cannot be visited by land, on account of the stupendous mountains, perpetually covered with snow, which divide the two parts of Greenland; while they have been rendered inaccessible by sea, by the vast quantity of ice driven from Spitzbergen, or East Greenland. One would imagine that there must have been some considerable alteration in the northern parts of the world since the 15th century, so that the coast of Greenland is now become almost totally inaccessible, though formerly visited with very little difficulty. It is also natural to ask, By what means the people of the eastern colony surmounted the above-mentioned obstacles when they went to the assistance of their western friends; how they returned to their own country; and in what manner historians learned the success of their expedition? Concerning all this we have very little satisfactory information.

⁵ Account of the colony. All that can be learned from the most authentic records is, that Greenland was divided into two districts, called *West Bygd* and *East Bygd*: that the western division contained four parishes and 100 villages: that the eastern district was still more flourishing, as being nearer to Iceland, sooner settled, and more frequented by shipping from Norway. There are also many accounts, though most of them romantic and slightly attested, which render it probable that part of the eastern colony still subsists, who, at some time or other, may have given the imperfect relation above mentioned. This colony, in ancient times, certainly comprehended twelve extensive parishes, one hundred and ninety villages, a bishop's see, and two monasteries. The present inhabitants of the western district are entirely ignorant of this part, from which they are divided by rocks, mountains, and deserts, and still more effectually by their apprehensions: for they believe the eastern Greenlanders to be a cruel, barbarous nation, that destroy and eat all strangers who fall into their hands. About a century after all intercourse between Norway and Greenland had ceased, several ships were sent successively by the kings of Denmark in order to discover the eastern district; but all of them miscarried. Among these adventurers, Mogens Heinsson, after having surmounted many difficulties and dangers, got sight of the land; which, however, he could not approach. At his return, he pretended that the ship was arrested in the middle of her course by certain rocks of loadstone at the bottom of the sea. The same year, 1576, in which this attempt was made, has been rendered remarkable by the voyage of Captain Martin Frobisher, sent upon the same errand by Queen Elizabeth. He likewise descried the land; but could not reach it, and therefore returned to England;

⁶ Attempts to re-discover the country.

yet not before he had sailed sixty leagues in the strait Greenland, which still retains his name, and landed on several islands, where he had some communication with the natives. He had likewise taken possession of the country in the name of Queen Elizabeth; and brought away some pieces of heavy black stone, from which the refiners of London extracted a certain proportion of gold. In the ensuing spring he undertook a second voyage, at the head of a small squadron, equipped at the expense of the public; entered the straits a second time; discovered upon an island a gold and silver mine; bestowed names upon different bays, islands, and headlands; and brought away a lading of ore, together with two natives, a male and a female, whom the English kidnapped.

Such was the success of this voyage, that another armament was fitted out under the auspices of Admiral Frobisher, consisting of 15 sail, including a considerable number of soldiers, miners, smelters, carpenters, and bakers, to remain all the winter near the mines in a wooden fort, the different pieces of which they carried out in the transports. They met with boisterous weather, impenetrable fogs, and violent currents upon the coast of Greenland, which retarded their operations until the season was far advanced. Part of their wooden fort was lost at sea; and they had neither provision nor fuel sufficient for the winter. The admiral therefore determined to return with as much ore as he could procure: of this they obtained large quantities out of a new mine, to which they gave the name of the Countess of Sussex. They likewise built a house of stone and lime, provided with ovens; and here, with a view to conciliate the affection of the natives, they left a quantity of small morrice-bells, knives, beads, looking glasses, leaden pictures, and other toys, together with several loaves of bread. They buried the timber of the fort where it could be easily found next year; and sowed corn, pease, and other grain, by way of experiment, to know what the country would produce. Having taken these precautions, they sailed from thence in the beginning of September; and after a month's stormy passage arrived in England: but this noble design was never prosecuted.

Christiern IV. king of Denmark, being desirous of discovering the old Greenland settlement, sent three ships thither, under the command of Captain Godske Lindenow; who is said to have reached the east coast of Greenland, where he traded with the savage inhabitants, such as they are still found in the western district, but saw no signs of a civilized people. Had he actually landed in the eastern division, he must have perceived some remains of the ancient colony, even in the ruins of their convents and villages. Lindenow kidnapped two of the natives, who were conveyed to Copenhagen; and the same cruel fraud (A) was practised

(A) Nothing can be more inhuman and repugnant to the dictates of common justice than this practice of tearing away poor creatures from their country, their families, and connections; unless we suppose them altogether destitute of natural affection: and that this was not the case with those poor Greenlanders, some of whom were brought alive to Copenhagen, appears from the whole tenor of their conduct, upon their first capture, and during their confinement in Denmark. When first captivated, they rent the air with their cries and lamentations: they even leaped into the sea; and, when taken on board, for some time refused all sustenance. Their eyes were continually turned towards their dear country, and their faces always bathed in tears. Even

Greenland. used by other two ships which sailed into Davis's straits, where they discovered divers fine harbours, and delightful meadows covered with verdure. In some places they are said to have found a considerable quantity of ore, every hundred pounds of which yielded twenty-six ounces of silver. The same Admiral Lindenow made another voyage to the coast of Greenland in the year 1606, directing his course to the westward of Cape Farewell. He coasted along the straits of Davis; and having made some observations on the face of the country, the harbours, and islands, returned to Denmark. Carsten Richards, being detached with two ships on the same discovery, described the high land on the eastern side of Greenland; but was hindered by the ice from approaching the shore.

Other expeditions of the same nature have been planned and executed with the same bad success, under the auspices of a Danish company of merchants. Two ships returned from the western part of Greenland loaded with a kind of yellow sand, supposed to contain a large proportion of gold. This being assayed by the goldsmiths of Copenhagen, was condemned as useless, and thrown overboard; but from a small quantity of this sand, which was reserved as a curiosity, an expert chemist afterwards extracted a quantity of pure gold. The captain, who brought home this adventure, was so chagrined at his disappointment, that he died of grief, without having left any directions concerning the place where the sand had been discovered. In the year 1654, Henry Moller, a rich Dane, equipped a vessel under the command of David de Nelles, who sailed to the west coast of Greenland, from which he carried off three women of the country. Other efforts have been made, under the encouragement of the Danish king, for the discovery and recovery of the old Iceland colony in Greenland; but all of them miscarried, and people began to look upon such expeditions as wild and chimerical. At length the Greenland company at Bergen in Norway, transported a colony to the western coast, about the 64th degree of latitude; and these Norwegians sailed in the year 1712, accompanied by the Reverend Hans Egede, to whose care, ability, and precision, we owe the best and most authentic account of modern Greenland.— This gentleman endeavoured to reach the eastern district, by coasting southwards, and advanced as far as the States promontory; but the season of the year, and continual storms, obliged him to return; and as he could not even find the strait of Frobisher, he concluded that no such place ever existed. In the year 1724, a ship, being equipped by the company, sailed on this discovery, with a view to land on the east side

opposite to Iceland; but the vast shoals of ice, which Greenland. barricaded that part of the coast, rendered this scheme impracticable. His Danish majesty, in the year 1728, caused horses to be transported to Greenland, in hope that the settlers might by their means travel over land to the eastern district: but the icy mountains were found impassable. Finally, Lieutenant Richards, in a ship which had wintered near the new Danish colony, attempted, in his return to Denmark, to land on the eastern shore; but all his endeavours proved abortive.

Mr Egede is of opinion, that the only practicable method of reaching that part of the country, will be to coast north about in small vessels, between the great flakes of ice and the shore; as the Greenlanders have declared, that the currents continually rushing from the bays and inlets, and running south-westwards along the shore, hinder the ice from adhering to the land; so that there is always a channel open, through which vessels of small burden might pass, especially if lodges were built at convenient distances on the shore, for the convenience and direction of the adventurers.

That part of the country which is now visited and Mr Egede's account of the country. settled by the Danes and Norwegians, lies between the 64th and 68th degrees of north latitude; and thus far it is said the climate is temperate. In the summer, which continues from the end of May to the middle of September, the weather is warm and comfortable, while the wind blows easterly; though even at this time storms frequently happen, which rage with incredible violence; and the sea-coasts are infested with fogs that are equally disagreeable and unhealthy.— Near the shore, and in the bays and islets, the low land is clothed with the most charming verdure; but the inland mountains are perpetually covered with ice and snow. To the northward of the 68th degree of latitude the cold is prodigiously intense; and towards the end of August all the coast is covered with ice, which never thaws till April or May, and sometimes not till the latter end of June. Nothing can exhibit a more dreadful, and at the same time a more dazzling, appearance, than those prodigious masses of ice that surround the whole coast in various forms, reflecting a multitude of colours from the sun-beams, and calling to mind the enchanted scenes of romance. Such prospects they yield in calm weather; but when the wind begins to blow, and the waves to rise in vast billows, the violent shocks of these pieces of ice dashing against one another, fill the mind with horror.— Greenland is seldom visited with thunder and lightning, but the *Aurora Borealis* is very frequent and bright. At the time of new and full moon, the tide rises and falls upon this coast

the countenance of his Danish majesty, and the caresses of the court and people, could not alleviate their grief. One of them was perceived to shed tears always when he saw an infant in the mother's arms; a circumstance from whence it was naturally concluded, that he had left his wife with a young child in Greenland. Two of them went to sea in their little canoes in hope of reaching Greenland; but one of them was mistaken. Other two made the same attempt: but were driven by a storm on the coast of Schonen, where they were apprehended by the peasants, and reconveyed to Copenhagen. One of them afterwards died of a fever, caught in fishing pearl, during the winter, for the governor of Kolding. The rest lived some years in Denmark; but at length, seeing no prospect of being able to revisit their native country, they sunk into a kind of melancholy disorder, and expired.

Greenland. coast about three fathoms; and it is remarkable, that the springs and fountains on shore rise and fall with the flux and reflux of the ocean.

The soil of Greenland varies like that of all other mountainous countries. The hills are very barren, being indeed frozen throughout the whole year; but the valleys and low grounds, especially near the sea, are rich and fruitful. The ancient Norwegian chronicles inform us, that Greenland formerly produced a great number of cattle; and that considerable quantities of butter and cheese were exported to Norway; and, on account of their peculiar excellency, set apart for the king's use. The same histories inform us, that some parts of the country yielded excellent wheat; and that large oaks were found here, which carried acorns as big as apples. Some of these oaks still remain in the southern parts, and in many places the marks of ploughed land are easily perceived. At present, however, the country is destitute of corn and cattle, though in many places it produces excellent pasture; and, if properly cultivated, would probably yield grain also. Mr Egede sowed some barley in a bay adjoining to the Danish colony. It sprang up so fast, that by the latter end of July it was in the full ear; but being nipped by a night-frost, it never arrived at maturity. This seed was brought from Bergen, where the summer is of greater heat and duration than in Greenland; but in all probability the corn which grows in the northern parts of Norway would also thrive here. Turnips and coleworts of an excellent taste and flavour are also produced here. The sides of the mountains near the bays are clothed with wild thyme, which diffuses its fragrance to a great distance. The herb tormentil is very common in this country, and likewise many others not described by the botanists. Among the fruits of Greenland we number juniper-berries, blue-berries, bil-berries, and bramble-berries.

Greenland is thought to contain many mines of metal, though none of them are wrought. To the southward of the Danish colony are some appearances of a mine of copper. Mr Egede once received a lump of ore from one of the natives; and here he found calamine of a yellow colour. He once sent a considerable quantity of sand of a yellow colour, intermixed with streaks of vermilion, to the Bergen company. They probably found their account in this present; for they desired him by a letter to procure as much of that sand as possible: but he was never able to find the place where he saw the first specimen. It was one of the smallest among a great number of islands; and the mark he had set up was blown down by a violent storm. Possibly this might be the same mineral of which Captain Frobiaker brought so much to England. This country produces rock-crystals both red and white, and whole mountains of the asbestos or incombustible flax. Around the colony, which is known by the name of *Good Hope*, they find a kind of bastard marble of various colours, which the natives form into bowls, lamps, pots, &c. All that has been said of the fertility of Greenland, however, must be understood only of that part which lies between the 60th and 65th degrees of latitude. The most northern parts are totally destitute of herbs and plants. The wretched inhabitants cannot find grass in sufficient quantities to

stuff into their shoes to keep their feet warm, but are obliged to buy it from those who inhabit the more southern parts.

The animals which abound most in Greenland are, rein-deer, foxes, hares, dogs, and white bears. The hares are of a white colour, and very fat; the foxes are of different colours, white, grayish, and bluish; and smaller than those of Denmark and Norway. The natives keep a great number of dogs, which are large, white, or speckled, and rough, with ears standing upright, as is the case with all the dogs peculiar to cold climates. They are timorous and stupid; and neither bay nor bark, but sometimes howl dismally. In the northern parts the natives yoke them in sledges; which, though heavy laden, they will draw on the ice at the rate of 70 miles in a short winter's day. These poor animals are very ill rewarded for their service; being left to provide for themselves, except when their masters happen to catch a great number of seals. On these occasions the dogs are regaled with the blood and entrails; at other times they subsist, like wild beasts, upon muscles and berries. Here also are found great numbers of ravens, eagles of a prodigious size, falcons, and other birds of prey; and likewise a kind of linnet, which warbles very melodiously. Whales, sword-fish, porpoises, &c. abound on the coasts; also holybut, turbot, cod, haddock, &c.

The people who now inhabit the western coasts of Greenland, and who, without doubt, are the descendants of the ancient *Schrellings*, who exterminated the first Iceland colony, bear a near resemblance to the Samoiedes and Laplanders in their persons, complexions, and way of life. They are short, brawny, and inclined to corpulency; with broad faces, flat noses, thick lips, black hair and eyes, and a yellowish tawny complexion. They are for the most part vigorous and healthy; but remarkably short-lived; few of them reaching the grand climacteric; and many dying in their infancy, and in the prime of youth. They are subject to a weakness in the eyes, occasioned by the piercing winds and the glare of the snow in the winter time. The leprosy is known among them, but is not contagious. Those that dwell in the northern parts are miserably tormented with dysenterica, rheums, and pulmonary disorders, boils, and epilepsy. The small-pox being imported among them from Copenhagen in the year 1734, made terrible havock among these poor people, who are utterly destitute of any knowledge of the medicinal art, and depend entirely for assistance upon their *angekuts* or conjurers. In their dispositions the Greenlanders are cold, phlegmatic, indolent, and slow of apprehension: but very quiet, orderly, and good-natured. They live peaceably together; and have every thing in common, without strife, envying, or animosity. They are civil and hospitable, but slovenly to a degree almost beyond the Hottentots themselves. They never wash themselves with water; but lick their paws like the cat, and then rub their faces with them. They eat after their dogs without washing their dishes; devour the lice which devour them; and even lick the sweat, which they scrape off from their faces with their knives. The women wash themselves with their own urine, which they imagine makes their hair grow; and in the winter-time go out immediately after, to let the liquor freeze upon their skin.

Greenland. They will often eat their victuals off the dirty ground, without any vessel to hold them in; and devour rotten flesh with the greatest avidity. In times of scarcity they will subsist on pieces of old skin, reeds, seaweed, and a root called *tugloronet*, dressed with train-oil and fat. The dung of rein deer taken from the intestines, the entrails of partridges, and all sorts of offals, are counted dainties among these savages; and of the scrapings of seal skins they make delicate pan-cakes. At first they could not taste the Danish provisions without abhorrence; but now they are become extremely fond of bread and butter, though they still retain an aversion to tobacco and spirituous liquors; in which particular they differ from almost all savages on the face of the earth.

The Greenlanders commonly content themselves with one wife; who is condemned, as among other savage nations, to do all the drudgery, and may be corrected, or even divorced, by the husband at pleasure. Heroes, however, and extraordinary personages, are indulged with a plurality of wives. Their young women are generally chaste and bashful; but at some of their feasts, in the midst of their jollity, a man retires with his neighbour's wife behind a curtain made of skins; and all the guests, thus coupled, retire in their turns. The women think themselves happy if an *angekut* or prophet will thus honour them with his caresses. These people never marry within the prohibited degrees of consanguinity, nor is it counted decent in a couple to marry who have been educated in the same family.— They have a number of ridiculous and superstitious customs; among which the two following are the most remarkable: While a woman is in labour the gossips hold a chamber-pot over her head, as a charm to hasten the delivery. When the child is a year old, the mother licks and slabbers it all over, to render it, as she imagines, more strong and hardy.

9
Language,
religion,
&c.

All the Greenlanders hitherto known speak the same language, though different dialects prevail in different parts of the country. It abounds with double consonants; and is so guttural, that the pronunciation of many words is not to be learned except by those who have been accustomed to it from their infancy. The letters C, D, F, Q, and X, are not known in their alphabet. Like the North Americans, and inhabitants of Kamtschatka, they have a great number of long polysyllables. Their words, nouns as well as verbs, are inflected at the end by varying the termination, without the help of articles: but their language being found defective, they have adopted a good many words from the Norwegian dialect. Notwithstanding the endeavours of the Danish missionaries, they have no great reason to boast of the proselytes they have made of the natives of Greenland. These savages pay great deference and respect to the Danes, whom indeed they obey as their masters, and hear the truths of the Christian religion expounded without doubting the veracity of their teachers; but at the same time they listen with the most mortifying indifference, without being in the least influenced by what they have heard. They believe in the immortality of the soul, and the existence of a spirit whom they call *Torngarsuk*; but of whom they have formed the most ridiculous notions. The *angekuts*, who are supposed to be his immediate ministers, differ con-

Greenland. cerning the principles of his existence; some affirming that he is without form or shape; others, that he has the shape of a bear; others, that he has a large human body with only one arm; while others affirm that he is no larger than a man's finger, with many other absurdities of a similar kind. They have also a peculiar kind of mythology, by which they believe all the elements to be full of spirits, from among which every one of their prophets is supplied with a familiar which they name *Torngack*, and who is always ready when summoned to his assistance.

The Greenlanders are employed all the year round either in fishing or hunting. At sea they pursue the whales, horses, seals, fish for eating, and sea fowl. On shore they hunt the rein-deer in different parts of the country. They drive these animals, which feed in large herds, into a narrow circle or defile, where they are easily slain with arrows. Their bow is made of fir-tree, wound about with the twisted sinews of animals; the string is composed of the same stuff, or of seal skin: the arrow is a full fathom in length, pointed with a bearded iron, or a sharp bone; but those with which they kill birds are blunt, that they may not tear the flesh. Sea fowls they kill with lances, which they throw to a great distance with surprising dexterity. Their manner of catching whales is quite different from that practised by the Europeans. About 50 persons, men and women, set out in one long boat, which is called a *kone-boat*, from *kone*, a "woman," because it is rowed by females only. When they find a whale, they strike him with harpoons, to which are fastened with long lines some seal skins blown up like bladders. These, by floating on the surface, not only discover the back of the whale, but hinder him from diving under water for any length of time. They continue to pursue him until he loses strength, when they pierce him with spears and lances till he expires. On this occasion they are clad in their spring coats, consisting of one piece, with gloves, boots, caps made of seal-skin so closely laced and sewed that they keep out water. Thus accoutred, they leap into the sea; and begin to slice off the fat, even under water, before the whale is dead.—They have many different ways of killing seals; namely, by striking them with a small harpoon equipped also with an air-bag; by watching them when they come to breathe at the air-holes in the ice, and striking them with spears; by approaching them in the disguise of their own species, that is, covered with a seal-skin, creeping upon the ice, and moving the head from side to side as the seals are accustomed to do. By this stratagem the Greenlander moves towards the unsuspecting seal, and kills him with a spear. The Greenlanders angle with lines made of whale-bone cut very small, by means of which they succeed wonderfully. The Greenland canoe, like that used in Nova Zembla and Hudson's bay, is about three fathoms in length, pointed at both ends, and three quarters of a yard in breadth. It is composed of thin rafts fastened together with the sinews of animals. It is covered with dressed seal-skins both below and above, in such a manner that only a circular hole is left in the middle, large enough to admit the body of one man. Into this the Greenlander thrusts himself up to the waist, and fastens the skin so tight about

Greenland. about him that no water can enter. Thus secured, and armed with a paddle broad at both ends, he will venture out to sea in the most stormy weather to catch seals and sea-fowl; and if he is overset, he can easily raise himself by means of his paddle. A Greenland in one of these canoes, which was brought with him to Copenhagen, outstripped a pinnace of 16 oars, manned with choice mariners.—The kono-boat is made of the same materials, but more durable; and so large, that it will contain 50 persons with all their tackle, baggage, and provisions. She is fitted with a mast, which carries a triangular sail made of the membranes and entrails of seals, and is managed without the help of braces and bowlings. These kones are flat bottomed, and sometimes 60 feet in length. The men think it beneath them to take charge of them; and therefore they are left to the conduct of the women, who indeed are obliged to do all the drudgery, including even the building and repairing their houses, while the men employ themselves wholly in preparing their hunting implements and fishing tackle.

The number of inhabitants in West Greenland in 1802 was estimated at 20,000. In the winter time the people dwell in huts built of stone or turf: on the one side are the windows, covered with the skins of seals or rein-deer. Several families live in one of these houses, possessing each a separate apartment, before which is a hearth with a great lamp placed on a treviti, over which hangs their kettle; above is a rack or shelf on which their wet clothes are dried. They burn train oil in their lamps; and instead of wick, they use a kind of moss, which fully answers the purpose. These fires are not only sufficient to boil their victuals; but likewise to produce such a heat, that the whole house is like a bagnio. The door is very low, that as little cold air as possible may be admitted. The house within is lined with old skins, and surrounded with benches for the conveniency of strangers. In the summer time they dwell in tents made of long poles fixed in a conical form, covered in the inside with deer skins, and on the outside with seal skins, dressed so that the rain cannot pierce them.

East Green-land. East Greenland was for a long time considered as a part of the continent of West Greenland, but is now discovered to be an assemblage of islands lying between $76^{\circ} 46'$ and $80^{\circ} 30'$ of north latitude, and between 9° and 20° of east longitude. It was discovered by Sir Hugh Willoughby in the year 1553, who called it *Groenland*; supposing it to be a part of the western continent. In 1595, it was again visited by William Barentz and John Cornelius, two Dutchmen, who pretended to be the original discoverers, and called the country *Spitzbergen*, or Sharp Mountains, from the many sharp-pointed and rocky mountains with which it abounds. They alleged that the coast discovered by Sir Hugh Willoughby was some other country; which accordingly the Hollanders delineated on their maps and charts by the name of *Willoughby Land*; whereas in fact no such land ever existed; and long before the voyage of these Dutchmen, Stephen Barrows, an English shipmaster, had coasted along a desolate country from N. Lat. 78° to $80^{\circ} 11'$, which was undoubtedly Spitzbergen. The sea in the neighbourhood of the islands of Spitzbergen abounds very much

with whales, and is the common resort of the whale-fishing ships from different countries, and the country itself is frequently visited by these ships; but till the voyage of the Hon. Capt. Phipps (afterwards Lord Mulgrave), by order of his majesty, the situation of it was erroneously laid down. It was imagined that the land stretched to the northward as far as 82° of north latitude; but Capt. Phipps found the most northerly point of land, called *Seven Islands*, not to exceed $80^{\circ} 30'$ of latitude. Towards the east he saw other lands lying at a distance, so that Spitzbergen plainly appeared to be surrounded by water on that side, and not joined to the continent of Asia, as former navigators had supposed. The north and west coasts also he explored, but was prevented by the ice from sailing so far to the northward as he wished. The coast appeared neither habitable nor accessible. It is formed of high, barren, black rocks, without the least marks of vegetation; in many places bare and pointed; in others covered with snow, appearing even above the clouds. The valleys between the high cliffs were filled with snow and ice. "This prospect," says Capt. Phipps, "would have suggested the idea of perpetual winter, had not the mildness of the weather, the smooth water, bright sunshine, and constant day-light, given a cheerfulness and novelty to the whole of this romantic scene." The current ran along this coast half a knot an hour north. The height of one mountain seen here was found by geometrical mensuration to be at one time $1503\frac{3}{4}$ feet, at another $1503\frac{1}{8}$ feet. By a barometer constructed after De Luc's method, the height was found to be $1588\frac{3}{4}$ feet. On this occasion Capt. Phipps has the following remarks. "I cannot account for the great difference between the geometrical measure and the barometrical according to M. de Luc's calculation, which amounts to 84.7 feet. I have no reason to doubt the accuracy of Dr Irving's observations, which were made with great care. As to the geometrical measure, the agreement of so many triangles, each of which must have discovered even the smallest error, is the most satisfactory proof of its correctness. Since my return I have tried both the theodolite and barometer, to discover whether there was any fault in either; and find them, upon trial, as I had always done before, very accurate."

There is good anchorage in Schmeerenburgh harbour, lying in N. Lat. $74^{\circ} 44'$, E. Long. $9^{\circ} 50' 45''$; in 13 fathoms, sandy bottom, not far from the shore, and well sheltered from all winds. Close to this harbour is an island called *Amsterdam Island*, where the Dutch used formerly to boil their whale-oil; and the remains of some conveniency erected by them for that purpose are still visible. The Dutch ships, excepting in time of war, still resort to this place for the later season of the whale-fishery.—The rocks about this place are chiefly a kind of marble or limestone. No appearances of metals were observed, nor any signs of ancient or modern volcanoes. No insects, or any species of reptiles, were seen, not even the common earth-worm. There were no springs or rivers; but great plenty of water was produced from the snow which melted on the mountains.

The most remarkable views which these dreary regions present are those called *Icebergs*. They are large bodies of ice filling the valleys between the high mountains.

Greenland, Greenock. mountains. Their face towards the sea is nearly perpendicular, and of a very lively light-green colour. One was about 300 feet high, with a cascade of water issuing from it. The black mountains on each side, the white snow, and greenish-coloured ice, composed a very beautiful and romantic picture. Large pieces frequently broke off from the icebergs, and fell with great noise into the water. One piece was observed to have floated out into the bay, and grounded in 24 fathoms; it was 50 feet high above the surface of the water, and of the same beautiful colour with the iceberg from which it had separated.

These islands are totally uninhabited, though it doth not appear but that human creatures could subsist on them, notwithstanding their vicinity to the pole.—Eight English sailors, who were accidentally left here by a whale-fishing ship, survived the winter, and were brought home next season. The Dutch then attempted to settle a colony on Amsterdam island above mentioned; but all the people perished, not through the severity of the climate, but of the scurvy, owing to the want of those remedies which are now happily discovered, and which are found to be so effectual in preventing and curing that dreadful disease.—The late account also of six Russian sailors who staid four years in this inhospitable country, affords a decisive proof, that a colony might be settled on East Greenland, provided the doing so could answer any good purpose.

GREENLAND Company. A joint stock of 40,000l. was by statute to be raised by subscribers, who were incorporated for 14 years from the first of October 1693, and the company to use the trade of catching whales &c. into and from Greenland, and the Greenland seas; they may make bye-laws for the government of the persons employed in their ships, &c. Stat. 4. and 5 W. III. cap. 17. This company was farther encouraged by parliament in 1696; but partly by unskillful management, and partly by real losses, it was under the necessity of entirely breaking up, before the expiration of the term assigned to it, ending in 1707. But any person who will adventure to Greenland for whale-fishing, shall have all privileges granted to the Greenland company, by 1 Anne, cap. 16. and thus the trade was again laid open. Any subjects may import whale-fins, oil, &c. of fish caught in the Greenland seas, without paying any customs, &c. stat. 10 Geo. I. cap. 16. And ships employed in the Greenland-fishery are to be of such burden, provided with boats, so many men, fishing-lines, harping irons, &c. and be licensed to proceed; and on their return shall be paid 20s. per ton bounty, for whale-fins, &c. imported; 6 Geo. II. cap. 33. The bounty was afterwards increased; but has been lately diminished, and since this diminution, the trade has increased. See *Whale-Fishery*.

GREENOCK, a sea-port town of Scotland, and one of the ports of the city of Glasgow. It is distant 24 miles from that city. The frith of Clyde here expands into a fine bason four miles wide, and is landlocked on all sides.

Greenock, till lately, was divided into what are called the old and new parishes. Certain lands disjoined from Inerkip and Houston, in the year 1636, by virtue of a petition from the proprietors to the lords of commission for plantation of kirks, &c. which received

the name of Greenock when erected into a parish. There are different opinions entertained respecting the origin of the name, but the most probable opinion is, that it is derived from the Gaelic *Grianeg*, which signifies the *bay of the sun*. It lies in the north-west part of the county of Renfrew, in the presbytery of Paisley, and synod of Glasgow and Ayr, with the frith of Clyde on the north. Greenock was erected into a burgh of barony in 1575, and is governed by two bailies and a council.

The parish of Greenock is hilly, with the exception of a small strip of level ground of various breadth, stretching along the shore. It abounds with peat for fuel to the inhabitants, vast quantities of which they can afford to dispose of to the neighbouring towns and villages.

The soil upon the shore is full of gravel, light and sandy, which needs much rain to produce even a tolerable crop. It produces, however, large quantities of excellent potatoes, and by the assistance of sea ware, much good barley and oats.

As far as is yet known, the parish of Greenock produces no minerals which are in the least remarkable. Freestone is the most common; while limestone, which has been but lately discovered, has been found in very small quantities. No traces of coal have yet been met with.

In descending from the hills, there are some rivulets which form beautiful cascades, and appear like wreathes of snow, when seen from the shore. The chief of them bears the name of Wallace, the celebrated champion of the liberties of Scotland.

On the west side of the bay of Greenock and Crawfurd-dike, formerly denominated the bay of St Lawrence, from a chapel in the vicinity consecrated to that saint, lies the new town of Greenock. In the beginning of the 18th century it consisted only of one row of houses covered with thatch, and had no vestige of a harbour for vessels; but at present it extends along the Clyde rather more than an English mile, but not more than a furlong in breadth. Before the year 1745, a new parish was erected in Greenock, by the permission of Sir John Shaw, who gave up to the heritors and elders the right of patronage; and lately a third parish.

Both the parishes did not contain more than 4000 persons about the year 1745, and in 10 years after, they had suffered a diminution of 142 persons, as appears from the return transmitted to Dr Webster. The increase of population has been rapid since that time, the number of inhabitants being 19,042 in 1811.

Improvements have kept pace with the progress of wealth and population. An infirmary was erected in 1808, and a bridewell in 1809. And in 1815 a new customhouse was begun, which was finished in 1817. It is a fine building, 172 feet long and 100 feet deep, and has a handsome Doric portico in front. About a third of the building is occupied by the excise. Two newspapers are published at Greenock, and for some years past there has been an annual exhibition of paintings and drawings. There are two commercial banks in the town, a provident bank, and a number of benefit societies. The harbour which has of late years been greatly enlarged and improved, has from 16 to 26 feet water at high tides, and is capable of receiving 500 sail of merchant vessels. There are three established churches in the town, a Gaelic chapel, and meeting-houses

Greenock, Greenwich. houses of Roman Catholics, Belief, Independents, Baptists, Burghers, and Antiburghers.

The town of Greenock is governed by a council of nine feuars, of whom two are bailies. It is a burgh of barony, erected by Sir John Shaw in the year 1757, who was at that time superior. The inhabitants of Greenock petitioned the Scotch parliament in 1700, for a fund to build a harbour, which was absolutely and unaccountably refused. This made them enter into a contract with Sir John Shaw, paying a voluntary assessment of sixteen pence on each sack of malt brewed into ale within the limits of the town. In the year 1740 the whole debt was extinguished, and a surplus remained of 27,000 merks.

In Greenock there are several dack manufactories, three soap and candle works, one saddle and shoe manufactory, and two sugar-houses, all carried on for exportation to a great extent.

In the year 1784, after peace with America, 436 vessels British and foreign, including outward and homeward bound, carrying 14,911 tons, were entered at the port of Greenock; and in 1791, there were 1962 vessels, the tonnage of which amounted to 31,704. In 1818, the registered shipping amounted to 40,195 tons. In the same year the duties of customs amounted to 351,871. and those of excise to 280,000. The revenues of the town and harbour were 10,000*l*.

GREENWICH, a town of the county of Kent, in England, pleasantly situated on the bank of the Thames, about five miles east from London. Here was formerly a royal palace, built by Humphry duke of Gloucester, enlarged by Henry VII. and completed by Henry VIII. The latter often chose this town for his place of residence; as did also the queens Mary and Elizabeth, who were born in it. The same Duke Humphry began a tower on the top of the steep hill in the park, which was finished by Henry VII. but afterwards demolished, and a royal observatory erected in its place by Charles II. furnished with mathematical instruments for astronomical observations, and a deep dry well for observing the stars in the day-time. The palace being afterwards much neglected, King Charles II. (who had enlarged the park, walled it about and planted it), pulled it down, and began another, of which he lived to see the first wing magnificently finished. But King William III. in 1694, granted it, with nine acres of ground thereto belonging, to be converted into a royal hospital for old and disabled seamen, the widows and children of those who lost their lives in the service, and for the encouragement of navigation. This wing, which cost King Charles 26,000*l*. is now the first wing of the hospital towards London. The front to the Thames consists of two ranges of stone buildings, with the ranger's house in the centre of the area, but detached from any part of the hospital. These buildings perfectly correspond with each other, and have their tops crowned with a stone ballustrade. The buildings which are facing the area, correspond with them, though in a finer and more elegant style; and have domes at their ends, which are 120 feet high, supported on coupled columns. Under one of these is the hall, which is finely painted by Sir James Thornhill, and contains many royal portraits; and under the other the chapel, which

by accident was destroyed by fire. This fire broke out in the hospital on the second of January 1779, and totally consumed the dome at the S. E. quarter of the building, with the chapel, which was the most elegant in the world, the great dining hall, and eight wards, containing the lodgings of near 600 pensioners. The dome was rebuilt about the year 1785, and the whole damage has since been repaired. On the sides of the gate which opens to these buildings from the park, are placed a large terrestrial and celestial globe, in which the stars are gilt; and in the centre of the area is a statue of George II. About 3000 old disabled seamen are maintained in this hospital, and 5400 out-pensioners receive assistance from the funds. Besides private benefactions, to the amount of near 60,000*l*. the parliament, in the year 1732, settled upon it the earl of Derwentwater's estate, to the value of 6000*l*. per annum. All strangers who see it, pay two-pence each; and this income is applied to the support of the mathematical school for the sons of sailors. For the better support of it, every seaman in the merchant service, pays sixpence a month, stopped out of their pay, and delivered in at the six-penny receiver's office in Tower-hill. On this account, a seaman, who can produce an authentic certificate of his being disabled, and rendered unfit for service, by defending any ship belonging to his majesty's British subjects, or in taking any ship from the enemy, may be admitted into this hospital, and receive the same benefit from it as if he had been in his majesty's immediate service. Besides the seamen and widows above mentioned, about 200 boys, the sons of seamen, are bred up for the service of the royal navy. Each of the mariners has a weekly allowance of seven loaves, weighing 16 ounces each; three pounds of beef, two of mutton, a pint of pease, a pound and a quarter of cheese, two ounces of butter, fourteen quarts of beer, and one shilling a-week tobacco-money; the tobacco-money of the boatswains is two shillings and sixpence a-week each, that of their mates one shilling and sixpence, and that of the other officers in proportion to their rank: besides which, each common pensioner receives once in two years, a suit of blue clothes, a hat, three pairs of stockings, two pairs of shoes, five neckcloths, three shirts, and two night-caps. Out of all that is given for showing the ball, only three-pence in the shilling is allowed to the person that shews them; the rest makes an excellent fund for the yearly maintenance of not less than 20 poor boys, who are the sons of mariners that have been either slain or disabled in the service of their country. The park is well stocked with deer, and affords as much variety, in proportion to its size, as any in the kingdom; but the views from the Observatory and the One-tree hill are beautiful beyond imagination, particularly the former. The projection of these hills is so bold, that you do not look down upon a gradually falling slope, or flat inclosures, but at once upon the tops of branching trees, which grow in knots and clumps out of deep hollows and embrowned dells. The cattle which feed on the lawns, which appear in breaks among them, seems moving in a region of fairy land. A thousand natural openings among the branches of the trees break upon little picturesque views of the swelling turf, which, when illuminated by the sun, have an effect pleasing beyond the

power

Greenwich
||
Gregory.

power of fancy to paint. This is the fore-ground of the landscape: a little farther, the eye falls on that noble structure the hospital, in the midst of an amphitheatre of wood; then the two reaches of the river make that beautiful serpentine which forms the Isle of Dogs, and present the floating millions of the Thames. To the left appears a fine tract of country, leading to the capital, which there finishes the prospect. The parish-church of Greenwich, rebuilt by the commissioners for erecting the 50 new churches, is a very handsome structure, dedicated to St Alphege, archbishop of Canterbury, who is said to have been slain by the Danes in the year 1012, on the spot where the church now stands. There is a college at the end of the town, fronting the Thames, for the maintenance of 20 decayed old house-keepers, 12 out of Greenwich, and eight who are to be alternately chosen from Spottisham and Castle-Rising in Norfolk. This is called *the duke of Norfolk's College*, though it was founded and endowed in 1613 by Henry earl of Northampton, the duke of Norfolk's brother, and by him committed to the care of the Mercers company. To this college belongs a chapel, in which the earl's body is laid; which, as well as his monument, was removed hither a few years ago from the chapel of Dover castle. The pensioners, besides meat, drink, and lodging, are allowed one shilling and sixpence a-week, with a gown every year, linen once in two years, and hats once in four years. In 1560, Mr Lambard, author of the *Perambulation of Kent*, also built an hospital, called *Queen Elizabeth's college*, said to be the first erected by an English Protestant. There are likewise two charity-schools in this parish. The river Thames is here very broad, and the channel deep; and at some very high tides the water is salt. This is the chief harbour for the king's yachts. In 1811 Greenwich contained 2315 houses, and 16,947 inhabitants. A market on Wednesday and Saturday was erected here in 1737, the direction of which is in the governors of the royal hospital, to which the profits arising from it were appropriated.

GREGARIOUS, among zoologists, a term applied to such animals as do not live solitary, but associate in herds or flocks.

GREGORIAN CALENDAR, that which shows the new and full moon, with the time of Easter, and the moveable feasts depending thereon, by means of epacts, disposed through the several months of the Gregorian year. See **CHRONOLOGY**, N^o 26.

GREGORIAN Telescope. See **OPTICS Index**.

GREGORIAN Year. See **CHRONOLOGY**, N^o 26.

GREGORY the Great, was born at Rome of a patrician family. He discovered such abilities in the exercise of the senatorial employments, that the emperor Justin the younger appointed him prefect of Rome. Pope Pelasgius II. sent him nuncio to Constantinople, to demand succours against the Lombards. When he thought of enjoying a solitary life, he was elected pope by the clergy, the senate, and the people of Rome. Besides his learning and diligence in instructing the church, both by writing and preaching, he had a very happy talent in winning over princes in favour of the temporal as well as spiritual interest of religion. He undertook the conversion of the English, and sent over some monks of his order, under the direction of Augustin their abbot. His morality with respect to the

chastity of churchmen was very rigid, asserting that a man who had ever known a woman ought not to be admitted to the priesthood; and he always caused the candidates for it to be examined upon that point. He likewise vigorously exerted himself against such as were found guilty of calumny. However, he flattered the emperor Phocas, while his hands were yet reeking with the blood of Mauritius, and of his three children, who had been butchered in his sight. He likewise flattered Brunehaut, a very wicked queen of France. He is accused of destroying the noble monuments of ancient Roman magnificence, that those who visited the city might not attend more to the triumphal arches than to holy things; and burnt a multitude of heathen books, Livy in particular. He died in 604.

GREGORY of Nazianzen, surnamed the *Divine*, was one of the most illustrious ornaments of the Greek church in the fourth age. He was made bishop of Constantinople in 379; but finding his election contested by Timotheus archbishop of Alexandria, he voluntarily resigned his dignity about 382, in the general council of Constantinople. His works are extant, in two volumes, printed at Paris in 1609. His style is said to be equal to that of the most celebrated orators of ancient Greece.

GREGORY, Theodorus, surnamed *Thaumaturgus* on account of his miracles, was the scholar of Origen; and was elected bishop of Neocæsarea, the place of his birth, about the year 240, during his absence. He assisted at the council of Antioch, in 255, against Paulus Samosetanus; and died in 270. He had the satisfaction of leaving only seventeen idolaters in his diocese, where there were but seventeen Christians when he was ordained. There is still extant of his, A gratulatory oration to Origen, A canonical epistle, and some other works.

GREGORY, bishop of Nyssa, one of the fathers of the church, and author of the Nicene creed, was born in Cappadocia, about the year 331. He was chosen bishop of Nyssa in 372, and banished by the emperor Valens for adhering to the council of Nice. He was nevertheless afterwards employed by the bishops in several important affairs, and died in 396. He wrote Commentaries on the Scriptures; Sermons on the mysteries; Moral discourses; Dogmatical treatises; Panegyrics on the saints; some letters on church discipline; and other works. His style is very allegorical and affected.

GREGORY of Tours, or *Georgius Florentius Gregorius*, one of the most illustrious bishops and celebrated writers of the sixth century, was descended from a noble family in Auvergne. He was educated by his uncle Gallus, bishop of Clermont; and distinguished himself so much by his learning and virtue, that in 573 he was chosen bishop of Tours. He afterwards went to Rome to visit the tomb of the apostles, where he contracted a friendship with Gregory the Great, and died in 595. This author was extremely credulous with regard to miracles. He wrote, 1. The history of France. 2. The lives of the saints; and other works. The best edition is that published by Father Rumart, 1699.

GREGORY, David, the son of the reverend John Gregory, minister of Drumoak, in the county of Aber-

Gregory. deen. He was born about the year 1628, educated by his father for business, and bound apprentice to a mercantile house in Holland. But as his love of letters exceeded his desire for money, he relinquished commerce in the year 1655, and on the death of an elder brother he succeeded to the estate of Kinnairdie, about 40 miles from Aberdeen, where he resided many years, and had no fewer than 32 children borne to him by two wives. Three of his sons became eminent for their extensive literature, and were at one time professors of mathematics in the universities of Oxford, Edinburgh, and St Andrews.

The neighbouring gentlemen made a jest of Mr Gregory for his ignorance of what was doing on his own farm, but esteemed him highly as a man of letters. Having studied physic merely for amusement, he practised gratis among the poor; and his knowledge of it being so extensive, he was employed by the nobility and gentry in the neighbourhood, but he would take no fees. Having much business during the day, he went very early to bed, rose to his studies about two or three in the morning, and then slept an hour or two before breakfast.

In the country where he dwelt he was the first person who had a barometer, to the changes in which, according to the changes in the weather, he paid great attention, and was once in great danger of being tried by the presbytery for witchcraft or conjuration. He was waited upon by a deputation of ministers, who inquired into the truth of certain reports which had come to their ears, whom he so far satisfied as to induce them to wave a prosecution against a man who, by the extensive knowledge of medicine which he possessed, was a public blessing to the country.

About the beginning of last century he removed to Aberdeen, and during Queen Anne's war he turned his attention to the improvement of artillery, to make great guns more destructive, and executed a model of his intended engine. We are informed by Dr Reid, that he knew a clock-maker who had been employed in making this model; but as he made so many different pieces without knowing their design, or the method of uniting them, he could give no consistent account of the whole. Mr Gregory being satisfied with his invention by various experiments, he desired his son to show it to Sir Isaac Newton, concealing the name of the inventor; but Sir Isaac was much displeased with it, and declared that the inventor was more entitled to punishment than reward, as it was solely calculated for destruction, and might come to be known to the enemy. That great man urged the necessity of destroying it, and it is probable that Mr Gregory's son, the Savilian professor, followed his advice, for the model was never found.

When the rebellion broke out in 1715, the old gentleman went a second time to Holland, and returned when it was over to Aberdeen, where he died about 1720, in the 93d year of his age, leaving behind him a history of his own times, which was never published.

GREGORY, James, one of the most eminent mathematicians of the 17th century, was a son of the Rev. Mr John Gregory minister of Drumoak in the county of Aberdeen, and was born at Aberdeen in 1638. His mother was a daughter of Mr David Anderson of

Finzaugh, a gentleman who possessed a singular turn for mathematical and mechanical knowledge. This mathematical genius was hereditary in the family of the Andersons, and from them seems to have been transmitted to their descendants of the name of Gregory. Alexander Anderson, cousin-german of the above-mentioned David, was professor of mathematics at Paris in the beginning of the 17th century, and published there in 1612, *Supplementum, Apollonii redivivi, &c.* The mother of James Gregory inherited the genius of her family; and observing in her son, while yet a child, a strong propensity to mathematics, she instructed him herself in the elements of that science. He received his education in the languages at the grammar-school of Aberdeen, and went through the usual course of academical studies in the Marischal college.

At the age of 24 he published his treatise, entitled *Optica Promota, seu abdita radiorum reflexorum et refractorum mysteria, geometricè enucleata: cui subnectitur appendix subtilissimorum astronomiæ problematon resolutionem exhibens*, London 1663: a work of great genius, in which he gave the world an invention of his own, and one of the most valuable of the modern discoveries, the construction of the reflecting telescope. This discovery immediately attracted the attention of the mathematicians, both of our own and of foreign countries, who were soon convinced of its great importance to the sciences of optics and astronomy. The manner of placing the two specula upon the same axis appearing to Sir Isaac Newton to be attended with the disadvantage of losing the central rays of the larger speculum, he proposed an improvement on the instrument, by giving an oblique position to the smaller speculum, and placing the eye-glass in the side of the tube. But it is worth remarking, that the Newtonian construction of that instrument was long abandoned for the original or Gregorian, which is at this day universally employed where the instrument is of a moderate size; though Mr Herschel has preferred the Newtonian form for the construction of those immense telescopes, which of late years he has so successfully employed in observing the heavens.

The university of Padua being at that time in high reputation for mathematical studies, James Gregory went thither soon after the publication of his first work; and fixing his residence there for some years, he published, in 1667, *Veru Circuli et Hyperboles quadratura*; in which he propounded another discovery of his own, the invention of an infinitely converging series for the areas of the circle and hyperbole. To this treatise, when republished in 1668, he added a new work, entitled, *Geometriæ pars universalis, inserviens quantitatum curvarum transmutatione et mensura*; in which he is allowed to have shown, for the first time, a method for the transmutation of curves. These works engaged the notice, and procured Mr Gregory the correspondence, of the greatest mathematicians of the age, Newton, Huygens, Halley, and Wallis; and their author being soon after chosen a fellow of the royal society of London, contributed to enrich the Philosophical Transactions at that time by many excellent papers. Through this channel, in particular, he carried on a dispute with Mr Huygens, upon the occasion of his treatise on the quadrature of the circle and hyperbole, to

Gregory. which that able mathematician had started some objections. Of this controversy, it is unnecessary to enter into particulars. It is sufficient to say, that, in the opinion of Leibnitz, who allows Mr Gregory the highest merit for his genius and discoveries, Mr Huygens has pointed out, though not errors, some considerable deficiencies in the treatise above mentioned, and shown a much simpler method of attaining the end in view.

In 1688, Mr James Gregory published at London another work, entitled *Exercitationes Geometricæ*, which contributed still to extend his reputation. About this time he was elected professor of mathematics in the university of St Andrew's; an office which he held for six years. During his residence there, he married, in 1669, Mary, the daughter of George Jameson the celebrated painter, whom Mr Walpole has termed the Vandyke of Scotland, and who was fellow-disciple with that great artist in the school of Rubens at Antwerp.

In 1674, he was called to Edinburgh, to fill the chair of mathematics in that university. This place he had held for little more than a year, when, in October 1675, being employed in showing the satellites of Jupiter through a telescope to some of his pupils, he was suddenly struck with total blindness, and died a few days after, at the early age of 37.

He was a man of an acute and penetrating genius. His temper seems to have been warm, as appears from the conduct of his dispute with Mr Huygens; and, conscious perhaps of his own merits as a discoverer, he seems to have been jealous of losing any portion of his reputation by the improvements of others upon his inventions.

GREGORY, *David*, Savilian professor of astronomy at Oxford, whom Dr Smith has termed *subtilissimi ingenii mathematicus*, was the eldest son of Mr Gregory of Kinnairdie, brother of the above-mentioned Mr James Gregory. He was born at Aberdeen in 1661, and received the earlier part of his education in that city. He completed his studies at Edinburgh; and, being possessed of the mathematical papers of his uncle, soon distinguished himself likewise as the heir of his genius. In the 23d year of his age, he was elected professor of mathematics in the university of Edinburgh; and published, in the same year, *Exercitatio Geometrica de dimensione figurarum; sive specimen methodi generalis dimetiendi quasvis figuras*, Edinburgh, 1684, 4to. He saw very early the excellence of the Newtonian philosophy; and had the merit of being the first who introduced it into the schools by his public lectures at Edinburgh. "He had (says Mr Whiston*) already caused several of his scholars to keep acts, as we call them, upon several branches of the Newtonian philosophy; while we at Cambridge, poor wretches, were ignomi-

nously studying the fictitious hypotheses of the Cartesian."

In 1691, on the report of Dr Bernard's intention of resigning the Savilian professorship of astronomy at Oxford, David Gregory went to London; and being patronized by Sir Isaac Newton, and warmly befriended by Mr Flamstead the astronomer royal, he obtained the vacant professorship, for which Dr Halley was a competitor. This rivalry, however, instead of animosity, laid the foundation of friendship between these eminent men; and Halley soon after became the colleague of Gregory, by obtaining the professorship of geometry in the same university. Soon after his arrival in London, Mr Gregory had been elected a fellow of the royal society; and, previously to his election into the Savilian professorship, had the degree of doctor of physic conferred on him by the university of Oxford (A).

In 1693, he published in the Philosophical Transactions a resolution of the Florentine problem *de Testudine veliformi quadribili*; and he continued to communicate to the public, from time to time, many ingenious mathematical papers by the same channel. In 1695, he printed at Oxford *Catoptrica et Dioptrica Sphericæ Elementa*; a work which, as he informs us in his preface, contains the substance of some of his public lectures read, eleven years before, at Edinburgh. This valuable treatise was republished first with additions by Dr William Brown, with the recommendation of Mr Jones and Dr Desaguliers; and afterwards by the latter of these gentlemen, with an appendix containing an account of the Gregorian and Newtonian telescopes, together with Mr Hadley's tables for the construction of both those instruments. It is not unworthy of remark, that, in the end of this treatise, there is an observation which shows, that what is generally believed to be a discovery of a much later date, the construction of achromatic telescopes, which has been carried to great perfection by Mr Dollond and Mr Ramsden, had suggested itself to the mind of David Gregory, from the reflection on the admirable contrivance in nature in combining the different humours of the eye. The passage is as follows: "Quod si ob difficultates physicas in speculis idoneis torno elaborandis et poliendis, etiamnum lentibus uti oporteat, fortassis media diversæ densitatis ad lentem objectivam componendam adhibere utile foret, ut à natura factum observamus in oculi fabrica, ubi cristallinus humor (sere ejusdem cum vitro virtutis ad radios lucis refringendos) aqueo et vitreo (aquæ quoad refractionem haud abimilibus) conjungitur, ad imaginem quam distinctè fieri poterit, à natura nihil frustra moliente, in oculi fundo depingendam." *Catopt. et Dioptr. Sphær. Elem. Oxon.* 1695, p. 98.

In 1702 our author published at Oxford, *Astronomiæ Physicæ*

(A) On obtaining the above professorship, he was succeeded in the mathematical chair at Edinburgh by his brother James, likewise an eminent mathematician; who held that office for 33 years, and retiring in 1725 was succeeded by the celebrated Maclaurin. A daughter of this professor James Gregory, a young lady of great beauty and accomplishments, was the victim of an unfortunate attachment, which furnished the subject of Mallet's well-known ballad of William and Margaret.

Another brother, Charles, was created professor of mathematics at St Andrew's by Queen Anne in 1707. This office he held with reputation and ability for 32 years; and, resigning in 1739, was succeeded by his son, who eminently inherited the talents of his family, and died in 1763.

Gregory. *Physico et Geometrica Elementa*; a work which is accounted his masterpiece. It is founded on the Newtonian doctrines, and was esteemed by Sir Isaac Newton himself as a most excellent explanation and defence of his philosophy. In the following year he gave to the world an edition in folio of the works of Euclid in Greek and Latin; in prosecution of a design of his predecessor Dr Bernard, of printing the works of all the ancient mathematicians. In this work, although it contains all the treatises attributed to Euclid, Dr Gregory has been careful to point out such as he found reason, from internal evidence, to believe to be the productions of some inferior geometrician. In prosecution of Dr Bernard's plan, Dr Gregory engaged, soon after, with his colleague Halley, in the publication of the Conics of Apollonius; but he had proceeded but a little way in his this undertaking when he died, in the 49th year of his age, at Maidenhead in Berkshire, A. D. 1710. To the genius and abilities of David Gregory, the most celebrated mathematicians of the age, Sir Isaac Newton, Dr Halley, and Dr Keill, have given ample testimonies. Indeed it appears that he enjoyed, in a high degree, the confidence and friendship of Sir Isaac Newton. This philosopher entrusted him with a manuscript copy of his *Principia*, for the purpose of making observations on that work. Of these observations there is a complete copy preserved in the library of the University of Edinburgh. They contain many valuable commentaries on the *Principia*, many interesting anecdotes, and various sublime mathematical discussions. Some of the paragraphs are in the hand-writing of Huygens, and they relate to the theory of light of this philosopher. The observations of Dr Gregory had come too late for the first edition of Newton's great work; but he availed himself of them in the second. Besides those works published in his lifetime, he left in manuscript, A Short Treatise of the Nature and Arithmetic of Logarithms, which is printed at the end of Dr Keill's translation of Commandine's Euclid; and a Treatise of Practical Geometry, which was afterwards translated, and published in 1745, by Mr Maclaurin.

Dr David Gregory married in 1695, Elizabeth the daughter of Mr Oliphant of Langtown in Scotland. By this lady he had four sons, of whom, the eldest, David, was appointed regius professor of modern history at Oxford by King George I. and died in 1767, in an advanced age, after enjoying for many years the dignity of dean of Christ-church in that university.

GREGORY, Dr John, professor of medicine in the university of Edinburgh, was the son of Dr James Gregory professor of medicine in King's college Aberdeen, and grandson of James the inventor of the Gregorian telescope. His father was first married to Catharine Forbes, daughter of Sir John Forbes of Monymusk; by whom he had six children, most of whom died in infancy. He married afterwards Ann Chalmers, only daughter of the Rev. Mr George Chalmers principal of King's college, by whom he had two sons and a daughter. John, the youngest of the three, was born at Aberdeen, Jan. 3. 1724. Losing his father when only in the 7th year of his age, the care of his education devolved on his grandfather Principal Chalmers, and on his elder brother Dr James Gregory, who, upon the resignation of their father a short time before his death, had been appointed to succeed him in the professorship

of medicine in King's college. He likewise owed much in his infant years, and during the whole course of his studies, to the care and attention of his cousin, the celebrated Dr Reid, afterwards of the university of Glasgow. The rudiments of our author's classical education he received at the grammar-school of Aberdeen; and under the eye of his grandfather, he completed, in King's college, his studies in the Latin and Greek languages, and in the sciences of ethics, mathematics, and natural philosophy. His master in philosophy and in mathematics was Mr Thomas Gordon, philosophy professor of King's college, who ably filled an academical chair for above half a century.

In 1742, Mr Gregory went to Edinburgh, where the school of medicine was then rising to that celebrity which has since so remarkably distinguished it. Here he attended the anatomical lectures of the elder Dr Monro, of Dr Sinclair on the theory of medicine, and of Dr Rutherford on the practice. He heard likewise the prelections of Dr Alston on the materia medica and botany, and of Dr Plummer on chemistry. The medical society of Edinburgh, instituted for the free discussion of all questions relative to medicine and philosophy, had begun to meet in 1737. Of this society we find Mr Gregory a member in 1742, at the time when Dr Mark Akenside, his fellow student and intimate companion, was a member of the same institution.

In the year 1745 our author went to Leyden, and attended the lectures of those celebrated professors Gaubius, Albinus, and Van Royen. While at this place he had the honour of receiving from the King's college of Aberdeen, his *alma mater*, who regarded him as a favourite son, an unsolicited degree of doctor of medicine; and soon after, on his return thither from Holland, he was elected professor of philosophy in the same university. In this capacity he read lectures during the years 1747, 1748, and 1749, on mathematics, on experimental philosophy, and on moral philosophy. In the end of 1749, however, he chose to resign his professorship of philosophy, his views being turned chiefly to the practice of physic, with which he apprehended the duties of this professorship, occupying a great portion of his time, too much interfered. Previously, however, to his settling as a physician at Aberdeen, he went for a few months to the continent; a tour of which the chief motive was probably amusement, though, to a mind like his, certainly not without its profit in the enlargement of ideas, and an increased knowledge of mankind.

Some time after his return to Scotland, Dr Gregory married in 1752, Elisabeth daughter of William Lord Forbes; a young lady who, to the exterior endowments of great beauty and engaging manners, joined a very superior understanding, and an uncommon share of wit. With her he received a handsome addition of fortune; and during the whole period of their union, which was but for the space of nine years, enjoyed the highest portion of domestic happiness. Of her character it is enough to say, that her husband, in that admired little work, *A Father's Legacy to his Daughters*, the last proof of his affection for them, declares, that "while he endeavours to point out what they should be, he draws but a very faint and imperfect picture of what their mother was." The field of medical practice at Aberdeen being at that time in a great measure pre-

Gregory. occupied by his elder brother Dr James Gregory, and others of some note in their profession, our author determined to try his fortune in London. Thither accordingly he went in 1754; and being already known by reputation as a man of genius, he found an easy introduction to many persons of distinction both in the literary and polite world. The late George Lord Lyttelton was his friend and patron. An attachment, which was founded on a striking similarity of manners, of tastes, and of dispositions, grew up into a firm and permanent friendship; and to that nobleman, to whom Dr Gregory was wont to communicate all his literary productions, the world is indebted for the publication of the *Comparative View of the State and Faculties of Man*, which made him first known as an author. Dr Gregory likewise enjoyed the friendship of the late Edward Montagu, Esq. and of his lady, the celebrated champion of the fame of Shakespeare, against the cavils and calumnies of Voltaire. At her assemblies, or *conversations*, the resort of taste and genius, our author had an opportunity of cultivating an acquaintance with many of the most distinguished literary characters of the present times.

In 1754 Dr Gregory was chosen fellow of the royal society of London; and daily advancing in the public esteem, it is not to be doubted, that, had he continued his residence in that metropolis, his professional talents would have found their reward in a very extensive practice. But the death of his brother, Dr James Gregory, in November 1755, occasioning a vacancy in the professorship of physic in King's college, Aberdeen, which he was solicited to fill, he returned to his native country in the beginning of the following year, and took upon him the duties of that office to which he had been elected in his absence.

Here our author remained till the end of the year 1764, when urged by a very laudable ambition, and presuming on the reputation he had acquired as affording a reasonable prospect of success in a more extended field of practice, he changed his place of residence for Edinburgh. His friends in that metropolis had represented to him the situation of the college of medicine as favourable to his views of filling a professorial chair in that university; which accordingly he obtained in 1766, on the resignation of Dr Rutherford, professor of the practice of physic. In the same year he had the honour of being appointed first physician to his majesty for Scotland on the death of Dr Whytt.

On his first establishment in the university of Edinburgh, Dr Gregory gave lectures on the practice of physic during the years 1767, 1768, and 1769. Afterwards, by agreement with Dr Cullen, professor of the theory of physic, these two eminent men gave alternate courses of the theory and of the practice.—As a public speaker, Dr Gregory's manner was simple, natural, and animated. Without the graces of oratory, which the subject he had to treat in a great degree precluded, he expressed his ideas with uncommon perspicuity, and in a style happily attuned between the formality of studied composition and the ease of conversation. It was his custom to premeditate, for a short time before entering the college, the subject of his lecture, consulting those authors to whom he had occasion to refer, and marking in short notes the arrangement of his intended discourse: then fully ma-

ster of his subject, and confident of his own powers, he trusted to his natural facility of expression to convey those opinions which he had maturely deliberated. The only lectures which he committed fully to writing, were those introductory discourses which he read at the beginning of his annual course, and which are published in these volumes under the title of *Lectures on the Duties and Qualifications of a Physician*. Of these, which were written with no view to publication, many copies were taken by his pupils, and some from the original manuscript, which he freely lent for their perusal. On hearing that a copy had been offered for sale to a bookseller, it became necessary to anticipate a fraudulent, and perhaps a mutilated publication, by authorising an impression from a corrected copy, of which he gave the profits to a favourite pupil. These lectures were first published in 1770, and afterwards in an enlarged and more perfect form in 1772.

In the same year, 1772, Dr Gregory published *Elements of the Practice of Physic*, for the use of Students: a work intended solely for his own pupils, and to be used by himself as a text-book to be commented upon in his course of lectures. In an advertisement prefixed to this work, he signified his intention of comprehending in it the whole series of diseases of which he treated in his lectures on the Practice of Physic; but this intention he did not live to accomplish, having brought down the work no further than to the end of the class of Febrile Diseases.—In his academical lectures, Dr Gregory never attempted to mislead the student by flattering views of the perfection of the science; but was, on the contrary, anxious to point out its defects; wisely judging that a thorough sense of the imperfection of an art or science is the first step towards its improvement. In this view he was careful to expose the fallaciousness of the several theories and hypotheses which have had the most extensive currency, and perpetually inculcated the danger of systematizing with limited experience, or an imperfect knowledge of facts. Yet in the work last mentioned it will appear from the order in which he has treated of the several diseases, that he did not entirely neglect the systematic arrangements of other authors. These, however, he warned his pupils, that he had not adopted from any conviction of the rectitude of those theories to which they referred, but only as affording that degree of method, and regularity of plan, which is found to be the best help to the study of any science. Considering a rational theory of physic to be as yet a desideratum, it was his object to communicate to his pupils the greatest portion of practical knowledge, as the only basis on which such a theory could ever be reared. His method, in treating of the several diseases, was first to mention those symptoms which are understood among physicians to characterize or define a disease; proceeding from the general to the more particular series of symptoms and their occasional varieties; to point out accurately the *diagnostic* symptoms, or those by which one disease is essentially distinguished from others that resemble it, and to mark likewise the *prognostics* by which a physician is enabled to conjecture of the probable event of a disease, whether favourable or otherwise. He then proceeded to specify the various causes, predisposing, occasional, and proximate; accounting, as far as he thought could be done

Gregory.

Gregory. on just principles, for the appearance of the several symptoms; and, finally, he pointed out the general plan of cure, the particular remedies to be employed, and the cautions requisite in the administration of them. Thus desirous of establishing the science of medicine upon the solid foundation of practice and experience; and knowing that many things asserted as facts by medical writers have been assumed on a very careless observation, while confirming a favourite theory; and that, on the other hand, many real and important facts have, from the same spirit of system, been explained away and discredited; he constantly endeavoured, both by his precept and example, to inculcate to his pupils the necessity of extreme caution either in admitting or in denying medical facts, or what are commonly given as such. To the desire of enforcing this necessary caution is owing that multitude of queries respecting matters of fact, as well as matters of opinion, which occurs in the *Elements of the Practice of Physic*.

Dr Gregory, soon after the death of his wife, and as he himself says, for the amusement of his solitary hours," employed himself in the composition of that admirable tract, entitled, *A Father's Legacy to his Daughters*; a work which, though certainly never intended by its author for the public eye, it would have been an unwarrantable diminution of his fame, and a capricious refusal of a general benefit to mankind, to have limited to the sole purpose for which it was originally designed. It was, therefore, with great propriety, published after the author's death by his eldest son. This work is a most amiable display of the piety and goodness of his heart, and his consummate knowledge of human nature and of the world. It manifests such solicitude for their welfare, as strongly recommends the advice which he gives. He speaks of the female sex in the most honourable terms, and labours to increase its estimation, whilst he plainly, yet genteelly and tenderly, points out the errors into which young ladies are prone to fall.—It is particularly observable, in what high and honourable terms he speaks of the Holy Scriptures, of Christian worship, and faithful ministers; how warmly he recommends to his daughters the serious and devout worship of God in public and private. He dwells largely on that temper and behaviour, which were particularly suited to their education, rank, and circumstances; and recommends that gentleness, benevolence, and modesty, which adorn the character of the ladies, and do particular honour to their sex. His advices, with regard to love, courtship, and marriage, are peculiarly wise, and interesting to them. They show what careful observation he had made on female domestic conduct, and on the different effects of possessing or wanting the virtues and qualities which he recommends. There is something peculiarly curious, animated, and useful, in his directions to them, how to judge of, and manifest an honourable passion in, and towards the other sex, and in the very accurate and useful distinction which he makes between true and false delicacy. Nothing can be more striking and affecting, nothing more likely to give his paternal advices their desired effect, than the respectful and affectionate manner in which he mentions his lady their mother, and the irreparable loss which he and they sustained by her early death. In short, in

this tract, the professor shines with peculiar lustre as a husband and father, and it is admirably adapted to promote domestic happiness.

These letters to his daughters were evidently written under the impression of an early death, which Dr Gregory had reason to apprehend from a constitution subject to the gout, which had begun to show itself at irregular intervals even from the 18th year of his age. His mother, from whom he inherited that disease, died suddenly in 1770, while sitting at table. Dr Gregory had prognosticated for himself a similar death; an event of which, among his friends, he often talked, but had no apprehension of the nearness of its approach. In the beginning of the year 1773, in conversation with his son Dr James Gregory, the latter remarking, that having for the three preceding years had no return of a fit, he might make his account with a pretty severe attack at that season; he received the observation with some degree of anger, as he felt himself then in his usual state of health. The prediction, however, was too true; for having gone to bed on the 9th of February 1773, with no apparent disorder, he was found dead in the morning. His death had been instantaneous, and probably in his sleep; for there was not the smallest discomposure of limb or of feature—a perfect *Euthanasia*.

Dr Gregory, in person, was considerably above the middle size. His frame of body was compacted with symmetry, but not with elegance. His limbs were not active; he stooped somewhat in his gait; and his countenance, from a fullness of feature and a heaviness of eye, gave no external indication of superior power of mind or abilities. It was otherwise when engaged in conversation. His features then became animated, and his eye most expressive. He had a warmth of tone and of gesture which gave a pleasing interest to every thing which he uttered; But, united with this animation, there was in him a gentleness and simplicity of manner, which, with little attention to the exterior and regulated forms of politeness, was more engaging than the most finished address. His conversation flowed with ease; and, when in company with literary men, without affecting a display of knowledge, he was liberal of the stores of his mind. He possessed a large share of the social and benevolent affections, which, in the exercise of his profession, manifested themselves in many nameless, but important, attentions to those under his care; attentions which, proceeding in him from an extended principle of humanity, were not squared to the circumstances or rank of the patient, but ever bestowed most liberally where they were most requisite. In the care of his pupils, he was not satisfied with a faithful discharge of his public duties. To many of these, strangers in the country, and far removed from all who had a natural interest in their concerns, it was matter of no small importance to enjoy the acquaintance and countenance of one so universally respected and esteemed.

GRE-HOUND. See *CANIS, MAMMALIA Index*.—Among a litter of gre-hound puppies, the best are always those which are lightest. These will make the nimblest dogs as they grow up. The gre-hound is best for open countries where there is little covert. In these places there will sometimes be a course after a hare of two or three miles or more, and both the dogs and the

Gregory, Gre-hound.

Gre-
hound,
Grenada.

game in sight all the while. It is generally supposed that the gre-hound bitch will beat the dog in running; but this seems to be an error; for the dog is both longer made, and considerably stronger, than the bitch of the same kind. In the breeding these dogs the bitch is principally to be regarded; for it is found by experience, that the best dog and a bad bitch will not get so good puppies as an indifferent dog with a good bitch. The dog and bitch should be as nearly as may be of the same age; and for the breeding of fine and perfect dogs, they should not be more than four years old. An old bitch may be used with a young dog, but the puppies of a young bitch and an old dog will never be good for any thing.

The general food for a gre-hound ought to be chippings or raspings of bread, with soft hones and gritles; and those chippings ought always to be soaked in beef or mutton broth.

The proper exercise for a gre-hound is coursing him three times a-week, and rewarding him with blood; which will animate him in the highest degree, and encourage him to prosecute his game. But the hare also should ever have fair play. She should have the law, as it is called; that is, have leave to run about twelve score yards before the dog is slipped at her, that he may have some difficulty in the course, and not pick up the game too easily. If he kills the hare, he must never be suffered to tear her; but she must be taken from him, his mouth cleaned of the wool, and the liver and lights given him by way of encouragement. Then he is to be led home, and his feet washed with butter and beer, and about an hour after he is to be fed.

When the dog is to be taken out to course, he should have nothing in the morning but a toast and butter, and then he is to be kennelled till taken out to the field. The kennelling these dogs is of great use, always giving them spirit and nimbleness when they are set loose: and the best way of managing a fine gre-hound is, never to let him stir out of the kennel, except at the times of feeding, walking, or coursing.

GRENADA, one of the Caribbee islands, lying in W. Long. 61. 30. N. Lat. 12. 10. It is the last of the Windward Caribbees; and lies 30 leagues north of New Andalsia, on the continent. It is about 30 miles in length, and in some places 15 in breadth. The chief port, formerly called *Louis*, now *St George's*, stands on the west side of the island, in the middle of a large bay, with a sandy bottom. It is said that 1000 barks, from 300 to 400 tons, may ride secure from storms; and that 100 ships, of 1000 tons each, may be moored in the harbour. A large round bason, which is parted from it by a bank of sand, would contain a considerable number of ships, if the bank was cut through: but by reason of it the large ships are obliged to pass within 80 paces of one of the mountains lying at the mouth of the harbour; the other mountain lying about half a mile distant. The island abounds with wild game and fish; it produces also very fine timber, but the cocoa-tree is observed not to thrive here so well as in the other islands. A lake on a high mountain, about the middle of the island, supplies it with fresh-water streams. Several bays and harbours lie round the island, some of which might be fortified

to great advantage; so that it is very convenient for shipping, not being subject to hurricanes. The soil is capable of producing tobacco, sugar, indigo, pease, and millet.

In 1638, M. Poincy, a Frenchman, attempted to make a settlement in Grenada; but was driven off by the Caribbeans, who resorted to this island in greater numbers than to the neighbouring ones, probably on account of the game with which it abounded. In 1650, Mons. Parquet, governor of Martinico, carried over from that island 200 men, furnished with presents to reconcile the savages to them; but with arms to subdue them, in case they should prove intractable. The savages are said to have been frightened into submission by the number of the Frenchmen: but, according to some French writers, the chief not only welcomed the new-comers; but, in consideration of some knives, hatchets, scissars, and other toys, yielded to Parquet the sovereignty of the island, reserving to themselves their own habitations. The Abbé Raynal informs us, that these first French colonists, *imagining* they had purchased the island by these trifles, assumed the sovereignty, and soon acted as tyrants. The Caribs, unable to contend with them by force, took their usual method of murdering all those whom they found in a defenceless state. This produced a war; and the French settlers having received a reinforcement of 300 men from Martinico, forced the savages to retire to a mountain; from whence, after exhausting all their arrows, they rolled down great logs of wood on their enemies. Here they were joined by other savages from the neighbouring islands, and again attacked the French, but were defeated anew; and were at last driven to such desperation, that 40 of them, who had escaped from the slaughter, jumped from a precipice into the sea, where they all perished, rather than fall into the hands of their implacable enemies. From thence the rock was called *le morne des sauteurs*, or "the bill of the leapers;" which name it still retains. The French then destroyed the habitations, and all the provisions of the savages; but fresh supplies of Caribbeans arriving, the war was renewed with great vigour, and great numbers of the French were killed. Upon this they resolved totally to exterminate the natives: and having according attacked the savages unawares, they inhumanly put to death the women and children, as well as the men; burning all their boats and canoes, to cut off all communication between the few survivors and the neighbouring islands. Notwithstanding all these barbarous precautions, however, the Caribbees proved the irreconcilable enemies of the French; and their frequent insurrections at last obliged Parquet to sell all his property in the island to the Count de Cerillac in 1657. The new proprietor, who purchased Parquet's property for 30,000 crowns, sent thither a person of brutal manners to govern the island. He behaved with such insupportable tyranny, that most of the colonists retired to Martinico; and the few who remained condemned him to death after a formal trial. In the whole court of justice that tried this miscreant, there was only one man (called *Archangeli*) who could write. A farrier was the person who impeached: and he, instead of the signatures, sealed with a horse-shoe; and Archangeli, who performed

Grenada.

Grenada. formed the office of clerk, wrote round it these words in French, "Mark of M. de la Brie, counsel for the court."

It was apprehended that the court of France would not ratify a sentence passed with such unusual formalities; and therefore most of the judges of the governor's crimes, and witnesses of his execution, disappeared. Only those remained whose obscurity screened them from the pursuit of the laws. By an estimate, taken in 1700, there were at Grenada no more than 251 white people, 53 free savages or mulattoes, and 525 slaves. The useful animals were reduced to 64 horses and 569 head of horned cattle. The whole culture consisted of three plantations of sugar and 52 of indigo.—The island had been sold in 1664 to the French West India company for 100,000 livres.

This unfavourable state of the affairs of Grenada was changed in 1714. The change was owing to the flourishing condition of Martinico. The richest of the ships from that island were sent to the Spanish coasts, and in their way touched at Grenada to take in refreshments. The trading privateers, who undertook this navigation, taught the people of that island the value of their soil, which only required cultivation. Some traders furnished the inhabitants with staves and utensils to erect sugar plantations. An open account was established between the two colonies. Grenada was clearing its debts gradually by its rich produce; and the balance was on the point of being closed, when the war in 1744 interrupted the communication between the two islands, and at the same time stopped the progress of the sugar-plantations. This loss was supplied by the culture of coffee, which was pursued during the hostilities with all the activity and eagerness that industry could inspire.—The peace of 1748 revived all the labours, and opened all the former sources of wealth. In 1753, the population of Grenada consisted of 1262 white people, 175 free negroes, and 11,991 slaves. The cattle amounted to 2298 horses or mules, 2456 head of horned cattle, 3278 sheep, 902 goats, and 331 hogs. The cultivation rose to 83 sugar plantations, 2,725,600 coffee trees, 150,300 cocoa-trees, and 800 cotton plants. The provisions consisted of 5,740,450 trenches of cassada, 933,596 banana trees, and 143 squares of potatoes and yams. The colony made a rapid progress, in proportion to the excellence of its soil; but in 1762 the island was taken by the British. At this time one of the mountains at the side of St George's harbour was strongly fortified, and might have made a good defence, but surrendered without firing a gun; and by the treaty concluded in 1763 the island was ceded to Britain. On this cession, and the management of the colony after that event, the abbé Baynal has the following remarks.—"This long train of evils [the ambition and mismanagement of his countrymen] has thrown Grenada into the hands of the English, who are in possession of this conquest by the treaty of 1763. But how long will they keep this colony? Or, will it never again be restored to France?—England has not made a fortunate beginning. In the first enthusiasm raised by an acquisition, of which the highest opinion had been previously formed, every one was eager to purchase estates there. They sold for much more than their real value. This caprice, by

expelling old colonists who were inured to the climate, has sent about 1,553,000l. out of the mother-country. This imprudence has been followed by another. The new proprietors, misled, no doubt, by national pride, have substituted new methods to those of their predecessors. They have attempted to alter the mode of living among their slaves. The negroes, who from their very ignorance are more attached to their customs than other men, have revolted. It hath been found necessary to send out troops, and to shed blood. The whole colony was filled with suspicions. The masters who had laid themselves under a necessity of using violent methods, were afraid of being burnt or massacred in their own plantations. The labours have declined, or been totally interrupted. Tranquillity has at length been restored. The number of slaves has been increased as far as 40,000, and the produce has been raised to the treble of what it was under the French government. The plantation will still be improved by the neighbourhood of a dozen of islands, called the *Grenadines* or *Grenadilles*, that are dependent on the colony. They are from three to eight leagues in circumference. The air is wholesome. The ground, covered only with thin bushes, has not been screened from the sun. It exhales none of those noxious vapours which are fatal to the husbandman. Carriacou, the only one of the Grenadines which the French have occupied, was at first frequented by turtle fishermen; who, in the leisure afforded them by so easy an occupation, employed themselves in clearing the ground. In process of time, their small number was increased by the accession of some of the inhabitants of Guadeloupe; who, finding that their plantations were destroyed by a particular sort of ants, removed to Carriacou. The island flourished from the liberty that was enjoyed there. The inhabitants collected about 1200 slaves, by whose labours they made themselves a revenue of near 20,000l. a-year in cotton.—The other Grenadines do not afford a prospect of the same advantages, though the plantation of sugar is begun there. It has succeeded remarkably well at Becouya, the largest and most fertile of these islands, which is no more than two leagues distant from St Vincent."

In the year 1779, the conquest of this island was accomplished by D'Estaign the French admiral, who had been prevented from attempting it before by his enterprise against St Vincent. Immediately after his conquest of St Lucia, however, being reinforced by a squadron under M. de la Motte, he set sail for Grenada with a fleet of 26 sail of the line and 12 frigates, having on board 10,000 land forces. Here he arrived on the second of July; and landed 3000 troops, chiefly Irish, being part of the brigade composed of natives of Ireland in the service of France. These were conducted by Count Dillon, who disposed them in such a manner as to surround the hill that overlooks and commands George's town, together with the fort and harbour. To oppose these, Lord M'Cartney, the governor, had only about 150 regulars, and 300 or 400 armed inhabitants; but though all resistance was evidently vain, he determined nevertheless to make an honourable and gallant defence. The preparations he made were such as induced D'Estaign himself to be present at the attack; and, even with his vast superiority of force, the first attack on the entrenchments proved

unsuccessful.

Grenada. unsuccessful. The second continued two hours; when the garrison were obliged to yield to the immense disparity of numbers who assaulted them, after having killed or wounded 300 of their antagonists. Having thus made themselves masters of the intrenchments on the hill, the French turned the cannon of them towards the fort which lay under it; on which the governor demanded a capitulation. The terms, however, were so extraordinary and unprecedented, that both the governor and inhabitants agreed in rejecting them; and determined rather to surrender without any conditions at all than upon those which appeared so extravagant. On this occasion D'Estaign is said to have behaved in a very haughty and severe manner; indulging his soldiers also in the most unwarrantable liberties, and in which they would have proceeded much farther had they not been restrained by the Irish troops in the French service.

In the mean time Admiral Byron, who had been conveying the homeward-bound West India fleet, hastened to St Vincent, in hopes of recovering it; but being informed, by the way, that a descent had been made at Grenada, he changed his course, hoping that Lord M'Cartney would be able to hold out till his arrival. On the sixth of July he came in sight of the French fleet; and, without regarding D'Estaign's superiority of six ships of the line and as many frigates, determined if possible to force him to a close engagement. The French commander, however, was not so confident of his own prowess as to run the risk of an encounter of this kind; and having already achieved his conquest, had no other view than to preserve it. His designs were facilitated by the good condition of his fleet; which being more lately come out of port than that of the British, sailed faster, so that he was thus enabled to keep at what distance he pleased. The engagement began about eight in the morning, when Admiral Barrington with his own and two other ships got up to the van of the enemy, which they attacked with the greatest spirit. As the other ships of his division, however, were not able to get up to his assistance, these three ships were necessarily obliged to encounter a vast superiority, and of consequence suffered exceedingly. The battle was carried on from beginning to end in the same unequal manner; nor were the British commanders, though they used their utmost efforts for this purpose, able to bring the French to a close engagement. Thus Captains Collingwood, Edwards, and Cornwallis, stood the fire of the whole French fleet for some time. Captain Fanshaw of the Monmouth, a 64 gun ship, threw himself singly in the way of the enemy's van; and Admiral Rowley and Captain Butchart fought at the same disadvantage: so that finding it impossible to continue the engagement with any probability of success, a general cessation of firing took place about noon. It recommenced in the same manner about two in the afternoon; and lasted, with different interruptions, till the evening. During this action some of the British ships had forced their way into St George's harbour, not imagining that the enemy were already in possession of the island. They were soon undeceived, however, by perceiving the French colours flying ashore, and the guns and batteries firing at them. This discovery put an end to the design which had brought on the engagement;

and as it was now high time to think of providing for the safety of the British transports, which were in danger from the number of the enemy's frigates, the engagement was finally discontinued. During this action some of Admiral Byron's ships had suffered extremely. The Lion of 64 guns, Captain Cornwallis, was found incapable of rejoining the fleet which were plying to windward; and was therefore obliged to bear away alone before the wind. Two other ships lay far astern in a very distressed situation; but no attempt was made to capture them, nor did the French admiral show the least inclination to renew the engagement.

Grenada was restored to Great Britain by the treaty of peace of 1783.—George's town, at St George's, is the residence of the governor.

When the levelling spirit of the French revolution threatened to banish all rational liberty and subordination from the face of the earth; the ill-fated island of Grenada did not escape the contagion. The slaves in this island were early tinctured with the love and admiration of those principles which subverted the monarchy of France. They were of consequence ready to revolt at the instigations of republican emissaries, who in 1795 effected a landing from the island of Guadaloupe in considerable numbers. Yet many of the slaves hesitated at first to take an active part in this unnatural rebellion against the British government; but their perseverance was at length shaken by the alluring temptations which were held out to them, of participating of the property of their plundered masters, and the flattering promises of total emancipation.

It is astonishing, as it seems repugnant to every feeling of human nature with which we are acquainted, that such of the slaves, both male and female, as had experienced the most humane treatment, and enjoyed the greatest share of their masters confidence, were the most active and cruel in this horrible insurrection. This seems to be a melancholy proof of an assertion often made by those who are inimical to the abolition of the slave-trade, that the most humane and benevolent treatment can make no impression on their native ferocity.

As the French troops had been too successful in their attack upon Guadaloupe, the disaffected negroes in Grenada who spoke the French language, as well as numbers of white people who were charmed with the extravagant doctrine of liberty and equality, were encouraged to project and execute a revolt from the British government, every step of which they marked with plunder and with blood. Having effected a landing at Grenville or *La Baye*, and Charlotte town, on different sides of the island, the insurgents, to the number of 100, surrounded the former place, and about one o'clock in the morning (March 6. 1795) plundered the dwelling and storehouses, and dragging the innocent, the astonished inhabitants into the streets, set them up as marks to be shot at. When they fell before the discharge of their musketry, the inhuman banditti mangled their bodies with cutlasses in the most shocking manner. At this time there were 14 English inhabitants in the town, only three of whom escaped the insatiable vengeance of those pretended lovers of freedom! Some escaped by swimming to the vessels which were then lying in the roads, while others, captured by the insurgents, were murdered on their way to the camp of the rebel

Grenada rebel chief Fedon, because they could not march so quickly as desired.

Gresham By the last returns made to the house of commons, the population of Grenada in 1811 was, slaves 29,381; whites 771; free people of colour 1210; total 31,362. In 1776 the exports from Grenada amounted to 600,000l.; and in 1809 they are stated to amount only to 189,000l., while the imports were 439,453l. The island is 123 miles S.W. of Barbadoes, and 71 miles N.W. of Tobago.

GRENADINES, or **GRENADILLOS**. See the preceding article.—In these islands, fresh water is found only in one place. A small spring has been discovered in the principal island Carriacou, by digging; but being of great value, it is kept locked by the proprietor. The capital of that island is called Hillsborough, in which there is a small church.

GRENAILLE, a name given by the French writers to a preparation of copper, which the Chinese use as a red colour in some of their finest china, particularly for that colour which is called *oil-red* or *red in oil*. The china-ware coloured with this is very dear. The manner in which they procure the preparation is thus: they have in China no such thing as silver coined money, but they use in commerce bars or masses of silver; these they pay and receive in large bargains; and among a nation so full of fraud as the Chinese, it is no wonder that these are too often adulterated with too great an alloy of copper. They pass, however, in this state, in the common payments. There are some occasions, however, such as the paying the taxes and contributions, on which they must have their silver pure and fine: on this occasion they have recourse to certain people, whose sole business it is to refine the silver, and separate it from the copper and the lead it contains. This they do in furnaces made for the purpose, and with very convenient vessels. While the copper is in fusion, they take a small brush, and dip the end of it into water; then striking the handle of the brush, they sprinkle the water by degrees upon the melted copper; a sort of pellicle forms itself by this means on the surface of the matter, which they take off while hot with pincers of iron, and immediately throwing it into a large vessel of cold water, it forms that red powder which is called the *grenaille*; they repeat the operation every time they in this manner separate the copper; and this furnishes them with as much of the *grenaille* as they have occasion for in their china works.

GRENOBLE, a large, populous, and ancient town of France, in the department of Isere, with a bishop's see. It contains a great number of handsome structures, particularly the churches and convents. The leather and gloves that are made here are highly esteemed. It is seated on the river Isere, over which there are two bridges to pass into that part called *Perriere*, a large street on the other side of the river. Population in 1815, 23,000. E. Long. 5. 49. N. Lat. 45. 12.

GRESHAM, **SIR THOMAS**, an opulent merchant of London, descended from an ancient and honourable family of Norfolk, was born in 1519. He was, as his father had been before him, appointed king's agent at Antwerp, for taking up money of the merchants; and in 1551 he removed to that city with his family. This employment was suspended on the accession of Queen Mary: but on proper representations, was re-

stored to him again. Queen Elizabeth conferred the honour of knighthood upon him, and made him her agent in foreign parts. It was at this time he thought proper to provide himself with a mansion-house in the city, suitable to his station and dignity; with which intention he built a large house on the west side of Bishopsgate-street, afterwards known by the name of *Gresham college*. His father had proposed building a house or exchange for the merchants to meet in, instead of walking in the open street; but this design remained for the son to accomplish. Sir Thomas went beyond his father: he offered, if the citizens would provide a proper piece of ground, to build a house at his own expence; which, being accepted, he fulfilled his promise after the plan of the exchange at Antwerp. When the new edifice was opened, the queen (Jan. 29. 1570) came and dined with the founder; and caused a herald with a trumpet to proclaim it by the name of the *Royal Exchange*. In pursuance also of a promise to endow a college for the profession of the seven liberal sciences, he made a testamentary disposition of his house in London for that purpose; leaving one moiety of the royal exchange to the corporation of London, and the other to the merchants company, for the salaries of seven lecturers in divinity, law, physic, astronomy, geometry, music, and rhetoric, at 50l. each per annum. He left several other considerable benefactions, and died in 1579. As to the college, it was afterwards pulled down in consequence of an application to parliament from the city, and the excise-office erected in its place. The lectures are read, or rather hurried through, in a chamber over the Royal Exchange. Those who have drawn Sir Thomas's character observe, that he had the happiness of a mind every way suited to his fortune; generous and benign; ready to perform any good actions, and encourage them in others. He was a great friend and patron of our celebrated martyrologist John Fox. He was well acquainted with the ancient and several modern languages; he had a very comprehensive knowledge of all affairs relating to commerce, whether foreign or domestic; and his success was not less, being in his time esteemed the highest commoner in England. He transacted Queen Elizabeth's mercantile affairs so constantly, that he was called *the royal merchant*; and his house was sometimes appointed for the reception of foreign princes upon their first arrival at London.

GREUSSEN, a town of Upper Saxony, in the county of Schweitzburg, 16 miles north of Erfurt, and 18 east of Mulhausen. Long. 11° 3' east, Lat. 51° 6' north.

GREVILLE, **FULKE**, Lord Brook, of Beauchamp's Court in Warwickshire, a poet and miscellaneous writer, was born in the year 1554, and descended from the noble families of Beauchamps of Powick and Willoughby de Brook. In company with his cousin Sir Philip Sidney, he began his education at a school in Shrewsbury; thence he went to Oxford, where he remained for some time a gentleman commoner, and then removed to Trinity-college in Cambridge. Having left the university, he visited foreign courts, and thus added to his knowledge of the ancient languages a perfect knowledge of the modern. On his return to England he was introduced to Queen Elizabeth by

Gresham
Greville

Greville
|
Grew.

his uncle Robert Greville, at that time in her majesty's service; and by means of Sir Henry Sidney, lord president of Wales, was nominated to some lucrative employments in that principality.

In the year 1581, when the French commissioners who came to treat about the queen's marriage with the duke of Anjou were sumptuously entertained with tilts and tournaments, Mr Greville, who was one of the challengers, so signalized himself, as to "win the reputation of a most valiant knight." He continued a constant attendant at court, and a favourite with the queen to the end of her reign; during which he obtained the office of treasurer of marine causes, also a grant of the manor of Wedgnoek, and likewise the honour of knighthood. In this reign he was several times elected member for the county of Warwick; and from the journals of the house seems to have been a man of business, as his name frequently appears in committees.

On the accession of King James I. he was installed knight of the Bath; and soon after obtained a grant of the ruinous castle of Warwick, which he repaired at a considerable expence, and where he probably resided during the former part of this reign: but in the year 1614, the twelfth of James I. he was made under treasurer, and chancellor of the exchequer, one of the privy council, and gentleman of the bed-chamber; and in 1620, was raised to the dignity of a baron by the title of Lord Brook of Beauchamp's Court. He was also privy-counsellor to King Charles I. in the beginning of whose reign he founded a history-lecture in Cambridge.

Having thus attained the age of 74, through a life of continued prosperity, universally admired as a gentleman and a scholar, he fell by the hand of an assassin, one of his own domestics, who immediately stabbed himself with the same weapon with which he had murdered his master. This fellow's name was Haywood; and the cause is said to have been a severe reprimand for his presumption in upbraiding his master for not providing for him after his death. It seems he had been witness to Lord Brook's will, and knew the contents. Some say he stabbed him with a knife in the back, others with a sword. This affair happened at Brook-house in Holborne.—Lord Brook was buried with great pomp in St Mary's church at Warwick, in his own vault, over which he had erected a monument of black and white marble, ordering at his death the following inscription to be engraven upon the tomb: "Fulke Greville, servant to Queen Elizabeth, counsellor to King James, and friend to Sir Philip Sidney. *Trophæum Peccati.*" He wrote several works both in verse and prose; among which are, 1. Two tragedies, *Alabam* and *Mustapha*. 2. A Treatise of Human Learning, &c. in verse, folio. 3. The Life of Sir Philip Sidney. 4. An inquisition upon Fame and Honour, in 86 stanzas. 6. *Cæcilia*, a collection of 109 songs. 7. His Remains, consisting of political and philosophical poems.

GREVIUS. See GREVIUS.

GREW, NEHEMIAH, a learned English writer, in the 17th century, had a considerable practice as a physician in London, and succeeded Mr Oldenburg in the office of secretary to the royal society. In this capacity, pursuant to an order of council, he drew up

a catalogue of the natural and artificial rarities belonging to the society, under the title of *Musæum Regalis Societatis*, &c. 1681. He also wrote, besides several pieces in the Philosophical Transactions, 1. The Comparative Anatomy of the Stomach and Guts, folio. 2. The Anatomy of Plants, folio. 3. *Tractatus de Salis Cathartici natura et usu*. 3. *Cosmologia Sacra*, or a Discourse of the Universe as it is the Creature and Kingdom of God, folio. He died suddenly in 1721.

GREWIA, a genus of plants belonging to the gymandria class, and in the natural method ranking under the 37th order, *Columniferæ*. See BOTANY Index.

GREY, or GRAY colour. See GRAY.

GREY, Lady Jane, a most illustrious and unfortunate lady, descended of the blood-royal of England by both parents, was the eldest daughter of Henry Grey marquis of Dorset, and Frances the daughter of Charles Brandon Lord Suffolk, by Mary the dowager of Louis XII. king of France, who was the youngest daughter of Henry VII. king of England. She was born in the year 1537, at Broadgate, her father's seat in Leicestershire. She discovered an early propensity to all kinds of good literature; and having a fine genius, improved under the tuition of Mr Elmer, she made a most surprising progress in the languages, arts, and sciences. She understood perfectly both kinds of philosophy, and could express herself very properly at least in the Latin and Greek tongues; and we are informed by Sir Thomas Chaloner (in Strype's Memorials, vol. iii. p. 93.), that she was well versed in Hebrew, Chaldee, Arabic, French, and Italian; "and (he adds) she played well on instrumental music, writ a curious hand, and was excellent at the needle." Chaloner also tells us, that she accompanied her musical instrument with a voice exquisitely sweet in itself, assisted by all the graces that art could bestow.

In the year 1553, the dukes of Suffolk and Northumberland, who were now, after the fall of Somerset, arrived at the height of power, began, on the decline of the king's health, to think how to prevent that reverse of fortune which, as things then stood, they foresaw must happen upon Edward's death. To obtain this end, no other remedy was judged sufficient but a change in the succession of the crown, and transferring it into their own families, by rendering Lady Jane queen. Those most excellent and amiable qualities which had rendered her dear to all who had the happiness to know her, joined to her near affinity to the king, subjected her to become the chief tool of an ambition so notoriously not her own. Upon this very account she was married to Lord Guilford Dudley, fourth son of the duke of Northumberland, without discovering to her the real design of the match; which was celebrated with great pomp in the latter end of May, so much to the king's satisfaction, that he contributed bounteously to the expence of it from the royal wardrobe. The young king Edward VI. died in July following; and our fair scholar, with infinite reluctance, overpowered by the solicitations of her ambitious friends, allowed herself to be proclaimed queen of England, on the strength of a deed of settlement extorted from that prince by her father-in-law the duke of Northumberland, which set aside the succession of Queen Mary, Queen Elizabeth, and Mary-queen

Grew
|
Grey.

Grey
||
Grief

queen of Scots. Her regal pageantry continued but a few days. Queen Mary's undoubted right prevailed; and the unfortunate Lady Jane Grey and her husband were committed to the Tower, and on the 13th of November arraigned and found guilty of high treason. On the 12th of February following they were both beheaded on Tower-hill. Her magnanimity in this dreadful catastrophe was astonishing. Immediately before her execution, she addressed herself to the weeping multitude with amazing composure and coherency: she acknowledged the justice of the law, and died in charity with that wretched world which she had so much reason to execrate. Thus did the pious Mary begin her reign with the murder of an innocent young creature of 18; who for simplicity of manners, purity of heart, and extensive learning, was hardly ever equalled in any age or country. But, alas! Jane was an obstinate heretic.—A few days before her execution, Fleckenham, the queen's chaplain, with a pious intention to rescue her poor soul from eternal misery, paid her frequent visits in the Tower, and used every argument in his power to convert her to the Popish religion; but he found her so much his superior in argument, that he gave up the contest: resigning her body to the block, and her soul to the devil.

Her writings are, 1. Four Latin Epistles; three to Bullenger, and one to her sister Lady Catherine. The last was written the night before her execution, in a blank leaf of a Greek Testament. Printed in a book entitled *Epistolæ Helveticæ Reformatioribus, vel ad eos scriptæ*, &c. Tiguri, 1742, 8vo. 2. Her Conference with Fleckenham. (Ballard). 3. A letter to Dr Harding, her father's chaplain. Printed in the Phoenix, vol. ii. p. 28. 4. A prayer for her own use during her confinement. In Fox's acts and monuments. 5. Four Latin verses; written in prison with a pin. They are as follows:

Non aliena putes, homini quæ obtingere possunt:
Sors hodierna mihi, tunc erit illa tibi.

Jane Dudley.

Deo juvante, nil nocet livor malus:
Et non juvante, nil juvat labor gravis.

Post tenebras spero lucem.

6. Her Speech on the Scaffold. (Ballard). It began thus: "My Lords, and you good Christian people who come to see me die; I am under a law, and by that law, as a never-erring judge, I am condemned to die: not for any thing I have offended the queen's majesty; for I will wash my hands guiltless thereof, and deliver to my God a soul as pure from such trespass as innocence from injustice; but only for that I consented to the thing I was enforced unto, constraint making the law believe I did that which I never understood." &c. —Hollinshed, Sir Richard Baker, Bale, and Fox, tell us that she wrote several other things, but do not mention where they are to be found.

GREY-Hound. See GRE-Hound.

GRIAS, a genus of plants belonging to the polyandria class, and in the natural method ranking with those of which the order is doubtful. See BOTANY Index.

GRIEF, or SORROW. The influence of this pas-

sion on the body is very great. Its effects resemble in several instances those of fear, with, however, some variations, owing perhaps to its being in general of longer duration. Grief diminishes the bodily strength in general, and particularly the force of the heart and circulation; as appears by the frequent sighs and deep respirations which attend it, which seem to be necessary exertions, in order to promote the passage of the blood through the lungs. It diminishes perspiration, obstructs the menstrual discharge, produces paleness of the skin, and œdematous complaints, and schirrus of the glandular parts. It aggravates the scurvy, and the malignity of putrid and contagious distempers, and renders people more apt to receive the infection of them. When it comes on suddenly, and in a great degree, it causes a palpitation of the heart, and renders the pulse irregular. Blindness, gangrene, and sudden death, have followed the excess of this sensation. Its effects of changing the colour of the hair are well known. Opiates, if not given in large doses, are good cordials in this case.

GRIEFENHAKEN, a town of Prussian Pomerania, in the duchy of Stetin, seated on the Oder, opposite to Gartz. E. Long. 14. 36. N. Lat. 53. 20.

GRIELUM, a genus of plants belonging to the decandria class. See BOTANY Index.

GRIERSON, CONSTANTIA, born of poor parents in the county of Kilkenny in Ireland, was one of the most learned women on record, though she died in 1733, at the early age of 27. She was an excellent Greek and Latin scholar; and understood history, divinity, philosophy, and mathematics. She proved her skill in Latin by her dedication of the Dublin edition of Tacitus to Lord Carteret, and by that of Terence to his son; to whom she also addressed a Greek epigram. She wrote many elegant English poems, several of which were inserted by Mrs Barber among her own. When Lord Carteret was lord lieutenant of Ireland, he obtained a patent for Mr Grierson to be king's printer; and to reward the uncommon merit of his wife, caused her life to be included in it.

GRIESSEWALDE, or GRIPSWALDE, a town of Upper Saxony, 15 miles south-east of Stralsund. E. Long. 13. 22. N. Lat. 54. 4.

GRIFFON (GRYPHUS, γρυψ), in the natural history of the ancients, the name of an imaginary bird of prey, of the eagle kind. They represented it with four legs, wings, and a beak; the upper part representing an eagle, and the lower a lion: they supposed it to watch over gold mines, hidden treasures, &c. The animal was consecrated to the sun; and the ancient painters represented the chariot of the sun as drawn by griffons. M. Spanheim observes the same of those of Jupiter and Nemesis.

The griffon in Scripture is that species of the eagle called in Latin *ossifraga*, the "osprey;" and גריפון, of the verb גרפ, *paras*, "to break."

The griffon is frequently seen on ancient medals; and is still borne in coat-armour. Guillim blazons it rampant; alleging, that any very fierce animal may be so blazoned as well as the lion. Sylvester, Morgan, and others, use the terms *segriciant* instead of rampant.

This is also an ornament of architecture in constant

Grief
||
Griffon.

use among the Greeks, and was copied from them, with the other elegancies of architectural enrichments, by the Romans. See SPHYNX.

GRIFLEA, a genus of plants belonging to the octandria class; and in the natural method ranking under the 17th order, *Calycanthemæ*. See BOTANY Index.

GRIMALDI, FRANCISCO, an eminent painter, generally known by the appellation of *Bolognese*, was born at Bologna in 1606, where he became a disciple of Annibal Caracci, and proved an honour to that illustrious master. From the school of Annibal he went to complete his studies at Rome, and improved himself daily, by copying the works of those artists in which he observed the greatest excellence, until his superior talents recommended him to the favour of Innocent X. who afforded him immediate opportunities of exerting his genius in the gallery of his palace at Monte Cavallo, and also in the Vatican. The merit of his performances very soon engaged the attention and applause of the public, and increased the number of his admirers and friends; among whom were the prince Pamphilio, and many of the principal nobility of Rome. His reputation reached Cardinal Mazarine at Paris, who sent for him, settled a large pension on him, and employed him for three years in embellishing his palace and the Louvre, by the order of Louis XIII. The troubles of the state, and the clamours raised against the cardinal, whose party he warmly espoused, put him so much in danger, that his friends advised him to retire among the Jesuits. He did so, and was of use to them; for he painted them a decoration for the exposition of the sacrament during the holy days, according to the custom of Rome. This piece was mightily relished at Paris: the king honoured it with two visits, and commanded him to paint such another for his chapel at the Louvre. Grimaldi after that returned to Italy; and at his arrival at Rome found his great patron Innocent X. dead: but his two successors Alexander VII. and Clement IX. honoured him equally with their friendship, and found him variety of employment. Grimaldi was amiable in his manners, as well as skilful in his profession: he was generous without profusion, respectful to the great without meanness, and charitable to the poor. The following instance of his benevolence may serve to characterize the man. A Sicilian gentleman, who had retired from Messina with his daughter during the troubles of that country, was reduced to the misery of wanting bread. As he lived over-against him, Grimaldi was soon informed of it; and in the dusk of the evening, knocking at the Sicilian's door, without making himself known, tossed in money and retired. The thing happening more than once, raised the Sicilian's curiosity to know his benefactor; who finding him out, by hiding himself behind the door, fell down on his knees to thank the hand that had relieved him. Grimaldi remained confused, offered him his house, and continued his friend till his death. He died of a dropsy at Rome in 1680, and left a considerable fortune among six children. The genius of Grimaldi directed him chiefly to landscape, which he executed most happily. His colouring is strong; his touch light and delicate; his situations are uncommonly pleasing; and the leafing of his trees is admirable. Sometimes, indeed, his colouring appears ra-

ther too green: but those landscapes, which he painted in the manner of Caracci, may serve as models for all those who admire the style of that school; and he designed his figures in an elegant taste. The pictures of this master are very rare, especially those of his best time; and whenever they are to be purchased, they afford large prices. Of his children above mentioned, the youngest, named *Alexander*, proved a good painter, in the same style and taste with his father, though very far inferior to him: some of the pictures of Alexander, however, are either artfully, or injudiciously, ascribed to Francisco.

GRIMBERGEN, a town of Brabant, with an abbey and a castle, six miles north of Brussels. E. Long. 4. 27. N. Lat. 50. 57.

GRIMM, a town in the electorate of Saxony, with a citadel, seated on the Muldaw, 10 miles south-east of Leipsic. E. Long. 12. 35. N. Lat. 51. 15.

GRIMMEN, a town of Swedish Pomerania, five miles south of Stralsund. E. Long. 13. 29. N. Lat. 54. 12.

GRIMSBY, GREAT, a large sea-port town of Lincolnshire in England, 170 miles north from London; and said to be the second, if not the first, corporation in England. It had anciently three convents and a castle. Here are several streets of good houses, and a church that looks like a cathedral. It was a place of great trade before its harbour was clogged up; yet the road before it is a good station for ships that wait for a wind to get out to sea. Its chief trade is in coals and salt brought by the Humber. The population in 1811 was estimated at 2747.

GRINDELWALD, a town of Switzerland, in the canton of Bern, seated among mountains, at the foot of a celebrated glacier, 25 miles south-east of Thun. E. Long. 7. 43. N. Lat. 46. 27.

GRINDING, or TRITURATION, the act of breaking or comminuting a solid body, and reducing it into powder. See PULVERISATION and LEVIGATION.

The painters colours are grinded on a marble or porphyry, either with oil or gum-water.

GRINDING is also used for rubbing or wearing off the irregular parts of the surface of a body, and reducing it to the destined figure, whether that be flat, concave, or the like.

The grinding and polishing of glass is a considerable art; for which see *Glass-Grinding*. For the grinding of optical glasses, see OPTICS, the *Mechanical Part*.

GRINDING, in cutlery, is an operation universally understood, by which edge-tools are sharpened. According to the usual practice, this operation is attended with considerable inconveniency, occasioned by the extrication of heat from friction. The steel very soon becomes ignited when the friction is performed on a dry stone; and even when immersed in water, the operation must be slow, to prevent the water from being thrown off by the centrifugal force; and if the water is poured on the stone from above by means of a cock, the quantity will be too small to preserve a sufficiently low temperature. But let the quantity of water be ever so great, if the instrument to be sharpened has not its point or edge so held as to meet the stream, it will almost inevitably be made softer.

To remedy these defects in the common mode of grinding, Mr Nicholson made an experiment with a

grindstone

Griffon
Grimaldi

Grimaldi
Grinding

Grinding. grindstone from Newcastle of a fine grit, 10 inches in diameter, with a block of mahogany to be employed with emery on the face of it. The grindstone and block were fixed on an axis, to be applied occasionally between the centres of a strong lathe. Both were cylindrical, and of the same diameter; the wood was grooved in opposite directions, in which the emery might be lodged. The face of the stone was left smooth, with a trough under it to hold the water. The cylinder of wood was faced with emery and oil, and the stone was used with water. A file was the instrument ground, and it was proposed to efface all the teeth. The mechanism of the lathe produced the rotation, by which the grinding apparatus made five revolutions in a second. The operation of the stone was slow, and the workman soon found inconvenience from the water in the trough being soon exhausted; but the emery cylinder cut rather faster. The friction operated by quick changes on the whole surface of the file, yet it soon became too hot to be held conveniently by the uncovered hand; and even when it was held with a cloth, such was the rapid increase of heat as to decompose the oil, which emitted an empyreumatic odour. When the stone became dry, the file was tried on the face of it, which soon became blue, and then nearly red hot. After this both cylinders were covered with tallow, and emery was sprinkled upon the wood cylinder, when the same instrument was held to the stone in rapid motion. The friction at first was scarcely apparent, but the pressure of the tool soon fused the tallow, and the stone cut very fast. When the tool after some time began to be a little heated, it was removed to a new zone of the cylinder, by which means the temperature was diminished. Similar effects accompanied the use of the wooden cylinder.

When oil was used upon the cylinder of wood, the heat occasioned by the friction raised the temperature of the instrument and of the oil in a state of fluidity; but when tallow instead of oil was employed, most of the heat was used in fusing that substance. The increased capacity of the melted tallow absorbed this heat, which became latent, and did not raise the temperature: and when the tallow already melted began to grow hot, as well as the tool, the employing another zone of consistent tallow reduced the temperature.

This discovery may yet be of considerable importance, for which we are indebted to the ingenuity of the learned editor of the Journal which bears his name, a performance which is much esteemed upon the continent as well as at home, by every man of literature and science.

GRINSTED, EAST and WEST; two towns near Salisbury in Wiltshire.

GRINSTED, East, a town 29 miles from London, seated on a hill, near the borders of Surry, near Ashdown forest. It has a handsome church, which was rebuilt after being burnt down 1683. On November 12. 1785, the beautiful tower having lately fallen to decay, fell down, and part lighting on the church very considerably damaged it. An hospital in the reign of King James I. for 31 poor people of this town, was built and endowed with 330l. a-year. It is a borough by prescription, governed by a bailiff and his brethren; has sent burgesses to parliament ever since the first of Edward II. who are elected by about 35

burgage-holders; had a charter for a monthly market from Henry VII. and is generally the place for the assizes. The returning officer here is the bailiff, who is chosen by a jury of burgage-holders. Its market is on Thursday; and its fairs, which are well frequented, are July 13. and December 11.; which last is a great one for Welsh runts, that are bought up here by the Kentish and Sussex farmers, and for fat hogs and other cattle. The population in 1811 was 2804.

GRINSTED, West, in Sussex, a town above 10 miles to the south-west of East-Grinsted, and containing in 1811 a population of 998 persons.

GRIPES, in *Medicine*, a colic or painful disorder of the lower belly, occasioned by irritating matters, or by wind in the intestines. See *MEDICINE Index*.

GRIPSWALD, a strong and considerable town of Pomerania in Germany; formerly imperial, but now subject to Prussia, with a good harbour and university. E. Long. 13. 53. N. Lat. 54. 12.

GRISGRIS, a superstition very prevalent among the negroes in the interior parts of Africa. The grisgris, according to Le Maire, are certain Arabic characters mixed with magical figures drawn by the marabuts or priests upon paper. Labat affirms, that they are nothing else than scraps of the Koran in Arabic; but this is denied by Barbot, who brought over one of these grisgris to Europe, and showed it to a number of persons deeply skilled in oriental learning. None of these could find the least trace of any character they understood. Yet, after all, this might be owing to the badness of the hand-writing; and the words are probably of the Mandingo language, though the characters are an attempt to imitate the Arabic. The poorest negro never goes to war without his grisgris, as a charm against wounds; and if it proves ineffectual, the priest transfers the blame on the immorality of his conduct. These priests invent grisgris against all kinds of dangers, and in favour of all desires and appetites; by virtue of which the possessors may obtain or avoid whatever they like or dislike. They defend them from storms, enemies, diseases, pains, and misfortunes; and preserve health, long life, wealth, honour, and merit, according to the marabuts. No clergy in the world are more honoured and revered by the people than these impostors are by the negroes; nor are any people in the world more impoverished by their priests than these negroes are, a grisgris being frequently sold at three slaves and four or five oxen. The grisgris intended for the head is made in the form of a cross, reaching from the forehead to the neck behind, and from ear to ear; nor are the arms and shoulders neglected. Sometimes they are planted in their bonnets in the form of horns; at other times, they are made like serpents, lizards, or some other animals, cut out of a kind of pasteboard, &c. There are not wanting Europeans, and otherwise intelligent seamen and merchants, who are in some degree affected with this weakness of the country, and believe that the negro sorcerers have an actual communication with the devil, and that they are filled with the malignant influence of that evil spirit, when they see them distort their features and muscles, make horrid grimaces, and at last imitate all the appearance of epileptics.

GRISONS, a people situated among the Alps, and allies of the Swiss. Their country is bounded on the

Grison: 
Grisons.

Grisons. north by the countries of Surgans and Bludenz, the canton of Glaris, and the principality of Lichtenstein; on the south by the canton's Italian bailiwics, the county of Chavenne, and the Valteline: on the east by the territories of Venice and Milan; and on the west by some of the Italian bailiwics, and the canton of Uri. It is divided into three leagues, viz. the *Grison or grey league*, the *league of the house of God*, and that of the *ten jurisdictions*; which unite and form one republic. The two first lie towards the south, and the third towards the north. The length of the whole is above 70 miles, and the breadth about 60. The inhabitants are said to have had the name of *Grisons* from the grey coats they wore in former times. This country, lying among the Alps, is very mountainous; but the mountains yield good pasture for cattle, sheep, and goats, with some rye and barley: in the valleys there is plenty of grain, pulse, fruits, and wine. This country also abounds with hogs and wild-fowl; but there is a scarcity of fish and salt, and their horses are mostly purchased of foreigners. The principal rivers are the Rhine, the Inn, and the Adda. Here are also several lakes, most of which lie on the tops of the hills. The language of the Grisons is either a corrupt Italian or the German. Each of the leagues is subdivided into several lesser communities, which are so many democracies; every male above 16 having a share in the government of the community, and a vote in the election of magistrates. Deputies from the several communities constitute the general diet of the Grison leagues, which meets annually, and alternately at the capital of each league; but they can conclude nothing without the consent of their constituents. This country was anciently a part of Rhetia. After the extinction of the Roman empire in the west, it was some time subject to its own dukes, or those of Swabia. Then the bishop of Coire, and other petty princes, dependent on the emperors of Germany, became masters of great part of it: at last, by the extinction of some, purchase, voluntary grants, and force, it got rid of all its lords, and erected itself into three distinct republics, each of which, as we observed already, is subdivided into a certain number of communities, which are a sort of republics, exercising every branch of sovereignty, except that of making peace or war, sending embassies, concluding alliances, and enacting laws relating to the whole country, which belong to the provincial diets of the several leagues. The communities may be compared to the cities of Holland, and the diets of the several leagues to the provincial states. The particular diets are composed of a deputy from each community; and both in them and the communities every thing is determined by a majority of votes. In the communities, every male above 16 has a vote. Besides the annual provincial diets for choosing the chiefs and other officers, and deliberating on the affairs of the respective leagues, there are general diets for what concerns all the three leagues or whole body. In both these, the representatives can do nothing of themselves, but are tied down to the instructions of their principals. There is a general seal for all the three leagues; and each particular league has a separate seal. Besides the stated times of meeting, extraordinary diets are sometimes summoned, when either the domestic affairs of the state or any foreign minister require it. In the ge-

Grisons. neral diets, the Grey League has 28 votes; that of the House of God, 23; and that of the Ten Jurisdictions, 15. These leagues, at different times, have entered into close alliances with the neighbouring cantons and their associates. The bailiwics, belonging in common to the three leagues are those of the Valteline, Chievane, Bormio, Meyenfeld, Malans, and Jennius; the officers of which are nominated successively by the several communities every two years. The yearly revenues arising to the Grisons from their bailiwics is said to amount to about 13,500 florins. The public revenues altogether are but small, though there are many private persons in the country that are rich. However, in case of any extraordinary emergency, they tax themselves in proportion to the necessity of the service and the people's abilities. They have no regular troops, but a well-disciplined militia; and upon occasion, it is said, can bring a body of 20,000 fighting men into the field: but their chief security arises from the narrow passes and high mountains by which they are surrounded.

Of the jurisprudence, religion, &c. of the Grisons, the following account is given by Mr Coxe in his travels in Switzerland. Throughout the three leagues the Roman law prevails, modified by the municipal customs. The courts of justice in each community are composed of the chief magistrate, who presides, and a certain number of jurymen, chosen by the people: they have no regular salaries, but receive for their attendance, a small sum, arising in some communities from the expenses of the process, which are defrayed by the criminals; in others from a share of the fines. They enjoy the power of pardoning or diminishing the penalty, and of receiving a composition in money. This mode of proceeding supposes what is as absurd in theory as it is contrary to experience, that judges will incline to mercy when it is their interest to convict; or will impartially inflict punishment, even when injurious to their own private advantage.—The prisoners are examined in private; frequently tortured for the purpose of forcing confession, when the judges either divide the fines, or remit the punishment for a composition. In some districts a criminal trial is a kind of festival to the judges, for whom a good repast is provided at the expense of the prisoner if convicted; and thus the following allusion, in Garth's *Dispensary*, applied with more wit than truth to our courts of justice, is literally fulfilled:—

'And wretches hang, that jurymen may dine.'

Capital punishments, however, are extremely rare; a circumstance arising not from a want of severity in the penal statutes, or from a propensity to mercy in the judges: but because the latter draw more advantages from fining than executing an offender. In a word, to use the expression of Burnet, which is as true at present as it was in his time, "Many crimes go unpunished, if the persons who commit them have either great credit or much money." It is remarkable, that torture is more frequently applied, and for smaller delinquencies, in these independent republics, than in the subject provinces. The infliction of it depends entirely upon the arbitrary will of the judges; a majority of whom may order it for an offence which is not capital, nor even punishable by corporal penalties. Thus it

Grisons. it is not uncommon, in those communities, where fines are divided among the judges, to torture women of loose conduct, for the purpose of compelling them to confess with whom they have been connected; for as such offences are punishable by fines, the more persons are convicted, the larger share of money is distributed among the judges for the trouble of their attendance. Even in the districts where the fines are paid to the community, torture is often no less wantonly inflicted, because when the prisoner is not found guilty, the expenses of the process fall upon the public, and the judges receive little emolument. Even in the civil courts most causes are decided by bribing the judges; and appeals in those communities, wherein they are admitted, scarcely serve any other end than to enlarge the sphere of corruption. Coire and a few other places are excepted from this general reflection.

The religion of the Grisons is divided into Catholic and Reformed. The doctrines of the reformation were first preached about the year 1524, and received at Fläsch, a small village in the Ten Jurisdictions upon the confines of Sargans; from thence they were extended to Meyensfeld and Malantz, and soon afterwards through the whole valley of Pretigau. The new opinions spread with such celerity, that before the end of the 16th century they were embraced by the whole league of the ten jurisdictions (excepting part of the community of Alvenew), the greatest part of the House of God, and a few communities in the Grey League. The difference of religion nearly excited a civil war between the two sects, as well at the first introduction of the Reformation as at the beginning of the troubles in the Valteline. In the latter instance, the two parties rose in arms; but the Catholics being overpowered by the Protestants, matters were amicably adjusted. Since that period all religious concerns have been regulated with perfect cordiality. According to the general consent of the three leagues, each community being absolute within its little territory, has the power of appointing its own particular worship, and the inhabitants are free to follow either the Catholic or Reformed persuasion. In the administration of civil affairs religion has no interference: the deputies of the general diet may be members of either communion, as chosen by the communities which they represent. By this moderate and tolerating principle, all religious dissensions have been suppressed as much as possible; and the most perfect amity subsists between the two sects.

In spiritual concerns, the Catholics for the most part are under the jurisdiction of the bishop of Coire. For the affairs of the Reformed churches, each league is divided into a certain number of districts, the ministers whereof assemble twice every year: these assemblies are called *colloquia*. Each colloquium has its president, and each league a superintendant called a *dean*. The supreme authority in spiritual concerns is vested in the synod, which is composed of the three deans, and the clergy of each league; the synod assembles every year alternately in each of the three leagues. Candidates for holy orders are examined before the synod. The necessary qualifications for admission into the church ought to be the knowledge of Hebrew, Greek, and Latin; but this rule is not strictly adhered to; many being ordained without the least acquaintance with either of those languages. Formerly Latin was solely

used, as well in the debates of the synod as for the purpose of examining the candidates; but at present that tongue grows more and more into disuse, and German is employed in its stead.

The number of reformed parishes in the whole three leagues amounts to 135, in the following proportion:—In the Grey League 46, in that of God's House 53, and in the League of Ten Jurisdictions 36. The ministers of these churches enjoy but very small salaries. The richest benefices do not perhaps yield more than 20*l.* or at most 25*l.* per annum, and the poorest sometimes scarcely 6*l.* This scanty income is attended with many inconveniences. It obliges the clergy who have families to follow some branch of traffic, to the neglect of their ecclesiastical studies, and to the degradation of the professional character. Another inconvenience is superadded to the narrowness of their income. In most communities the ministers, though confirmed by the synod, are chosen by the people of the parish, and are solely dependent on their bounty. In 1798, the Grisons, who had formerly been only the allies of the Swiss, were incorporated with the confederacy as a canton, which still remained however divided into the three leagues as before. The whole population of the Grisons has been recently estimated at 73,000, of whom 26,000 speak German, 10,000 Italian, and 37,000 the Romansh, or ancient Rhetian language. The canton furnishes a contingent of 1200 men, but in money only 750*l.* to the Helvetic confederacy.

GRIST, in country affairs, denotes corn ground, or ready for grinding.

GRIT, or **GRITSTONE**, a kind of stone which is used for building and for millstones and grindstones; and sometimes for filtering water.

GROAT, an English money of account, equal to four pence. Other nations, as the Dutch, Polanders, Saxons, Bohemians, French, &c. have likewise their groats, groots, groches, gros, &c. In the Saxon times, no silver coin bigger than a penny was struck in England, nor after the Conquest, till Edward III. who, about the year 1351, coined grosses, i. e. *groats*, or great pieces, which went for 4*d.* a-piece: and so the matter stood till the reign of Henry VIII. who, in 1504, first coined shillings.

GROATS, in country affairs, oats after the hulls are off, or great oat-meal.

GROCERS, anciently were such persons as engrossed all merchandise that was vendible; but now they are incorporated, and make one of the companies of the city of London, which deals in sugar, foreign fruits, spices, &c.

GROENLAND, or **SPITZBERGEN**. See **GREENLAND**.

GROGRAM, a kind of stuff made of silk and mohair.

GROIN, that part of the belly next the thigh.

GROIN, among builders, is the angular curve made by the intersection of two semi-cylinders or arches; and is either regular or irregular.—A *regular* groin is when the intersecting arches, whether semicircular or semielliptical, are of the same diameters and heights. An *irregular* groin is where one of the arches is semicircular and the other semielliptical.

GROMWELL. See **LITHOSPERMUM**, **BOTANY** *Index*.

GRONINGEN, the most northerly of the Seven

Grisons
Groningen.

Groningen
Gronovius

United Provinces, is bounded on the north by the German ocean; on the south, by the county of Drenthe; on the east, by the kingdom of Hanover; and on the west by the province of Friesland, from which it is parted by the river Lauwers. Its greatest length from south-east to north-west is about 47 miles; but its breadth is very unequal, the greatest being about 33 miles. Here are rich pastures, large herds of great and small cattle, plenty of sea and river fish, and of turf, with some forests and corn-land. There are several rivers in the province, of which the principal is the Hunse; and a great number of canals and dykes. The surface is level, and lies so low that the whole province is intersected by a multitude of canals and wet ditches for the purpose of carrying off the water, while it is protected by dykes against the inundations of the sea. In the towns there are some manufactures of linen and woollen. The population is computed at 146,000, upon a surface of 770 square miles. The province had anciently governors, under the title of *burggraves*; but their power being limited, the people enjoyed great privileges. Afterwards it became subject to the bishop of Utrecht; but shook off his yoke at last, and recovered its liberty. In 1536 it submitted to Charles V. and in 1579 acceded to the union of Utrecht. The colleges before the revolution were much the same here as in the other provinces, viz. the provincial states, council of state, provincial tribunal, and chamber of accounts; and six deputies were sent to the states-general.

GRONINGEN, the capital of the province of that name, is situated about 12 miles from the nearest shore of the German ocean, at the conflux of several rivulets, which form the Hunse and Fivel. Ships of considerable burden can come up to the city, in consequence of which it enjoys a pretty good trade. It was formerly very strong, but its fortifications are now much neglected. The university here was founded in 1615, and is well endowed out of the revenues of the ancient monasteries. The town, which was formerly one of the Hanse, and has still great privileges, is large and populous, being the seat of the high colleges, and containing three spacious market-places, and 27 streets, in which are many fine houses, besides churches and other public structures. By the river Fivel and the Ems, it has a communication with Westphalia. In 1672 it made such a gallant resistance against the bishop of Munster, that he is said to have lost 10,000 men before it. Rodolphus Agricola and Veselius, two of the most learned men of the age in which they lived, were born here. Under the jurisdiction of this city is a considerable district, called the *Gorecht*. E. Long. 6. 25. Lat. 53. 10.

GRONOVIA, a genus of plants belonging to the pentandria class; and in the natural method ranking under the 34th order, *Cucurbitaceæ*. See BOTANY *Index*.

GRONOVIVS, JOHN FREDERIC, a very learned critic, was born at Hamburg in 1613; and having travelled through Germany, Italy, and France, was made professor of polite learning at Deventer, and afterwards at Leyden, where he died in 1671. He published, 1. *Diatriba in Statii, &c.* 2. *De sestertiis*. 3. Correct editions of Seneca, Statius, T. Livy, Pliny's

Natural History, Tacitus, Aulus Gellius, Phædrus' *Gronovius* Fables, &c. with notes; and other works.

GRONOVIVS, James, son of the preceding, and a very learned man, was educated first at Leyden, then went over to England, where he visited the universities, consulted the curious MSS. and formed an acquaintance with several learned men. He was chosen by the grand duke to be professor at Pisa, with a considerable stipend. He returned into Holland, after he had resided two years in Tuscany, and consulted the MSS. in the Medicean library. In 1679, he was invited by the curators of the university to a professorship; and his inaugural dissertation was so highly approved of, that the curators added 400 florins to his stipend, and this augmentation continued to his death in 1716. He refused several honourable and advantageous offers. His principal works are, *The Treasure of Greek Antiquities*, in 13 vols. folio; and a great number of dissertations and editions of ancient authors. He was compared to Schioppus for the virulence of his style; and the severity with which he treated other great men who differed from him, exposed him to just censure.

GROOM, a name particularly applied to several superior officers belonging to the king's household, as groom of the chamber, groom of the stole. See STOLE, and WARDROBE.

GROOM is more particularly used for a servant appointed to attend on horses in the stable.—The word is formed from the Flemish *grom*, "a boy."

GROOVE, among miners, is the shaft or pit sunk into the earth, sometimes in the vein, and sometimes not.

GROOVE, among joiners, the channel made by their plough in the edge of a moulding, style, or rail, to put their pannels in, in wainscoting.

GROSE, FRANCIS, Esq. F. A. S. was born about the year 1731, and was the son of Mr Francis Grose, a jeweller of Richmond, by whom the coronation crown of George II. was filled up. Young Grose obtained an independent fortune by the death of his father, which happened in the year 1769. He was paymaster and adjutant in the Surry militia, but dissipation so far prevented him for some time from paying proper attention to his duty, that in his own humorous mode of expressing himself, he kept but two books of accounts, his right and left hand pockets. The losses which this thoughtless conduct occasioned him, awakened his dormant talents, and he resolved to turn his attention to literary pursuits. His education was classical, to which he united an excellent taste for drawing, which induced him to commence his "Views of Antiquities in England and Wales." He began this work in numbers in 1773, and completed it in 1776; and by it he obtained both reputation and profit, the latter of which his almost unpardonable liberality had rendered extremely needful. In 1777 he added other two volumes to his English views, which included the islands of Guernsey and Jersey, finished in 1778. All his expectations were fully gratified by the publication of this work, and during the remainder of his life he continued to publish others, which in general increased his reputation as an author, and always tended to augment his wealth. In the summer of 1789 he paid a visit to Scotland, and in

1790.

1790 began to publish in numbers, his views taken in that country. He next proceeded to Ireland, with a view to give a similar description of that country; but on the 6th of May 1791, while at Dublin in the house of Mr Horne, he was suddenly seized at table with an apoplectic fit, and immediately expired. He was buried in Drumcondra churchyard near Dublin.

Although his literature was very respectable, it was even exceeded by his good humour, by his convivial and friendly turn of mind. As both at home and abroad he was always in the best company, his knowledge of the world was so extensive, that his conversation was always useful and entertaining. He was free from the malignity and pride of some authors, for as he felt the independence of his own talents, he scorned to degrade others. Of the most careless, open, and artless disposition, he was often the prey of the designing, and has more than once embarrassed himself by too implicit confidence in the probity of others. A tale of distress never failed to touch his heart, and make the tear of commiseration glide down his cheek.

Besides the works formerly mentioned, he published a treatise on ancient armour and weapons; a classical dictionary of the vulgar tongue, military antiquities, &c.

GROSS, a foreign money, in divers countries, answering to our groat.

GROSS is used among us for the quantity of twelve dozen.

Gross Weight, is the weight of merchandises and goods, with their dust and dross, as also of the bag, cask, chest, &c. wherein they are contained; out of which gross weight, allowance is to be made of tare and tret.

GROSS, or *Grossus*, in our ancient law-writers, denotes a thing absolute, and not depending on another. Thus, *villain in gross*, *villanus in grosso*, was a servant, who did not belong to the land, but immediately to the person of the lord; or a servile person not appendant, or annexed to the lord or manor, and to go along with the tenures as appurtenant to it; but like other personal goods and chattels of his lord, at his lord's pleasure and disposal.

GROSS, *Advowson in*. See ADVOWSON.

GROSS-BEAK, the trivial name of the *coccythraustes*, or *haw-finch*, which is the *LOXIA coccythraustes*. See ORNITHOLOGY *Index*.

GROSSULARIA, the GOOSEBERRY. See RIBES, BOTANY *Index*.

GROTESQUE, or GROTESK, in sculpture and painting, somewhat whimsical, extravagant, and monstrous; consisting either of things that are merely imaginary, and have no existence in nature; or of things so distorted, as to raise surprise and ridicule. The names arise hence, that figures of this kind were anciently much used to adorn the *grottoes* wherein the tombs of eminent persons or families were inclosed. Such was that of Ovid, whose grotto was discovered near Rome about one hundred years ago.

GROTIUS, HUGO, or more properly HUGO DE GROËT, one of the greatest men in Europe, was born at Delft in 1583. He made so rapid a progress in his studies, that at the age of 15 he had attained a great knowledge in philosophy, divinity, and civil law; and a yet greater proficiency in polite literature, as appeared

by the commentary he had made at that age on Martianus Capella. In 1598, he accompanied the Dutch ambassador into France, and was honoured with several marks of esteem by Henry V. He took his degree of doctor of laws in that kingdom; and at his return to his native country, devoted himself to the bar, and pleaded before he was 17 years of age. He was not 24 when he was appointed attorney-general. In 1613 he settled in Rotterdam, and was nominated syndic of that city; but did not accept of the office till a promise was made him that he should not be removed from it. This prudent precaution he took from his foreseeing, that the quarrels of the divines on the doctrine of grace, which had already given rise to many factions in the state, would occasion revolutions in the chief cities. The same year he was sent into England on account of the divisions that reigned between the traders of the two nations, on the right of fishing in the northern seas; but he could obtain no satisfaction. He was afterwards sent to England, as it is thought, to persuade the king and the principal divines to favour the Arminians; and he had several conferences with King James on that subject. On his return to Holland, his attachment to Barneveldt involved him in great trouble; for he was seized, and sentenced to perpetual imprisonment in 1619, and to forfeit all his goods and chattels. But after having been treated with great rigour for above a year and a half in his confinement, he was delivered by the advice and artifice of his wife, who having observed that his keepers had often fatigued themselves with searching and examining a great trunk full of foul linen which used to be washed at Gorkum, but now let to pass without opening it, she advised him to bore holes in it to prevent his being stifled, and then to get into it. He complied with this advice, and was carried to a friend's house in Gorkum; where dressing himself like a mason, and taking a rule and trowel, he passed through the marketplace, and stepping into a boat went to Valvet in Brabant. Here he made himself known to some Arminians, and hired a carriage to Antwerp. At first there was a design of prosecuting his wife, who staid in the prison; and some judges were of opinion that she ought to be kept there in her husband's stead: however, she was released by a plurality of voices, and universally applauded for her behaviour. He now retired into France, where he met with a gracious reception from that court, and Louis XIII. settled a pension upon him. Having resided there eleven years, he returned to Holland, on his receiving a very kind letter from Frederic Henry prince of Orange: but his enemies renewing their persecution, he went to Hamburgh; where, in 1634, Queen Christina of Sweden made him her counsellor, and sent him ambassador into France. After having discharged the duties of this office above eleven years, he returned in order to give an account to Queen Christina of his embassy; when he took Holland in his way, and received many honours at Amsterdam. He was introduced to her Swedish majesty at Stockholm; and there begged that she would grant his dismissal, in order that he might return to Holland. This he obtained with difficulty; and the queen gave him many marks of her esteem, though he had many enemies at this court. As he was returning, the ship in

Grotius.

Grotius
|
Grotto.

which he embarked was cast away on the coast of Pomerania; and being now sick, he continued his journey by land; but was forced to stop at Rostock, where he died, on the 28th of August 1645. His body was carried to Delft, to be interred in the sepulchre of his ancestors. Notwithstanding the embassies in which he was employed, he composed a great number of excellent works; the principal of which are, 1. A treatise *De jure belli et pacis*, which is esteemed a master-piece. 2. A Treatise on the Truth of the Christian Religion. 3. Commentaries on the Holy Scriptures. 4. The History and Annals of Holland. 5. A great number of letters. All which are written in Latin.

GROTSCAW, a town of Turkey in Europe, in the province of Servia, where a battle was fought between the Germans and Turks, in the year 1739, in which the Germans were forced to retreat. It is 15 miles S. from Belgrade. E. Long. 21. 0. N. Lat. 45. 0.

GROTSKAW, a strong town of Germany, capital of a province of the same name in Silesia. It is very agreeably seated in a fruitful plain. E. Long. 17. 35. N. Lat. 50. 42.

GROTTO, or **GROTTA**, a large deep cavern or den in a mountain or rock. The word is Italian, *grotta*, formed, according to Menage, &c. from the Latin *crypta*. Du Cange observes, that *grotta* was used, in the same sense in the corrupt Latin.

The ancient anchorites retired into dens and grottoes, to apply themselves the more attentively to meditation.

Okey-hole, Elden-hole, Peak's-hole, and Pool's-hole, are famous among the natural caverns or grottoes of our country.

The entrance to Okey-hole, on the south side of Mendip-hills, is in the fall of those hills, which is beset all about with rocks, and has near it a precipitate descent of near twelve fathoms deep, at the bottom of which there continually issues from the rocks a considerable current of water. The naked rocks above the entrance show themselves about 30 fathoms high, and the whole ascent of the hill above is about a mile, and is very steep. As you pass into this vault, you go at first upon a level, but advancing farther, the way is found to be rocky and uneven, sometimes ascending and sometimes descending. The roof of this cavern, in the highest parts, is about eight fathoms from the ground, but in many particular places it is so low, that a man must stoop to get along. The breadth is not less various than the height, for in some places it is five or six fathoms wide, and in others not more than one or two. It extends itself in length about two hundred yards. People talk much of certain stones in it, resembling men and women, and other things; but there is little matter of curiosity in these, being only shapeless lumps of a common spar. At the farthest part of the cavern there is a good stream of water, large enough to drive a mill, which passes all along one side of the cavern, and at length slides down about six or eight fathoms among the rocks, and then pressing through the clefts of them, discharges itself into the valley. The river within the cavern is well stored with eels, and has some trouts in it; and these cannot have come from without, there being so great a fall near the entrance. In dry summers, a great number of frogs are seen all along

this cavern, even to the farther part of it; and on the roof of it, at certain places, hang vast numbers of bats, as they do in almost all caverns, the entrance of which is either level, or but slightly ascending or descending; and even in the more perpendicular ones they are sometimes found, provided they are not too narrow, and are sufficiently high. The cattle that feed in the pastures through which this river runs, have been known to die suddenly sometimes after a flood; this is probably owing to the waters having been impregnated, either naturally or accidentally, with lead ore.

Elden-hole is a huge profound perpendicular chasm, three miles from Buxton, ranked among the natural wonders of the Peak. Its depth is unknown, and is pretended to be unfathomable. Cotton tells us he sounded 884 yards; yet the plummet still drew. But he might easily be deceived, unless his plummet was very heavy; the weight of a rope of that length might well make the landing of the plummet scarce perceivable.

Peak's-hole and Pool's-hole are two very remarkable horizontal caverns under mountains; the one is situated near Castleton, and the other is just by Buxton. They seem to have owed their origin to the springs which have their current through them; when the water had forced its way through the horizontal fissures of the strata, and had carried the loose earth away with it, the loose stones must fall down of course: and where the strata had few or no fissures, they remained entire; and so formed these very irregular arches, which are now so much wondered at. The water which passes through Pool's-hole is impregnated with particles of limestone, and has incruited the whole cavern in such a manner that it appears as one solid rock.

In grottoes are frequently found crystals of the rock, stalactites, and other natural conglaciations, and those often of an amazing beauty. M. Homberg conjectures, from several circumstances, that the marble pillars in the grotto of Antiparos vegetate or grow. That author looks on this grotto as a garden, whereof the pieces of marble are the plants; and endeavours to show, that they could only be produced by some vegetative principle. See **ANTIPAROS**.

At Foligno in Italy is another grotto, consisting of pillars and orders of architecture of marble, with their ornaments, &c. scarcely inferior to those of art; but they all grow downwards: so that if this too be a garden, the plants are turned upside down.

Grotto del Cani, a little cavern near Pozzuoli, four leagues from Naples, the air of which is of a mephitical or noxious quality; whence also it is called *bocca venenosa*, the poisonous mouth.

Two miles from Naples (says Dr Mead), just by the Lago de Agnano, is a celebrated mofeta, commonly called *la Grotto del Cani*, and equally destructive to all within the reach of its vapours. It is a small grotto about eight feet high, twelve long, and six broad; from the ground arises a thin, subtle, warm fume, visible enough to a discerning eye, which does not spring up in little parcels here and there, but in one continued stream, covering the whole surface of the bottom of the cave; having this remarkable difference from common vapours, that it does not like smoke disperse itself into the air, but quickly after its rise falls back again, and

Grotto.

Grotto. returns to the earth; the colour of the sides of the grotto being the measure of its ascent: for so far it is of a darkish-green, but higher only common earth. And as I myself found no inconvenience by standing in it, so no animal, if its head be above this mark, is the least injured. But when, as the manner is, a dog, or any other creature, is forcibly kept below it, or, by reason of its smallness, cannot hold its head above it, it presently loses all motion, falls down as dead or in a swoon, the limbs convulsed and trembling; till at last no more signs of life appear than a very weak and almost insensible beating of the heart and arteries; which, if the animal be left a little longer, quickly ceases too, and then the case is irrecoverable; but if it be snatched out, and laid in the open air, it soon comes to life again, and sooner if thrown into the adjacent lake." The fumes of the grotto, the same author argues, are no real poison, but act chiefly by their gravity; else the creatures could not recover so soon, or if they did, some symptoms, as faintness, &c. would be the consequence of it. He adds, "that in creatures killed therewith, when dissected, no marks of infection appear; and that the attack proceeds from a want of air, by which the circulation tends to an entire stoppage; and this so much the more, as the animal inspires a fluid of a quite different nature from the air, and so in no respect fit to supply its place. Taking the animal out, while yet alive, and throwing it into the neighbouring lake, it recovers: this is owing to the coldness of the water, which promotes the contraction of the fibres, and so assists the retarded circulation; the small portion of air which remains in the vesiculæ, after every expiration, may be sufficient to drive out the noxious fluid. After the same manner, cold water acts in a *deliquium animi*: the lake of Agnano has no greater virtue in it than others."

The air in this grotto was for a long time reckoned to be of a poisonous nature, and thought to *suffocate* the animals which breathed it. Dr Hales imagined that it destroyed the elasticity of the air, caused the vesicles of the lungs to collapse, and thus occasioned sudden death.—It is now, however, found that this air is nothing else than fixed air, or carbonic acid gas, which issues from the earth in that place in great quantity.

Grotto del Serpi, is a subterraneous cavern near the village of Sassa, eight miles from the city of Braccano in Italy, described by Kircher thus: "The *grotto del serpi* is big enough to hold two persons. It is perforated with several fistular apertures, somewhat in manner of a sieve; out of which, at the beginning of the spring season, issues a numerous brood of young snakes of divers colours, but all free from any particular poisonous quality. In this cave they expose their lepers, paralytics, arthritics, and elephantiac patients, quite naked; where, the warmth of the subterraneous steams resolving them into a sweat, and the serpents clinging variously all around, licking and sucking them, they become so thoroughly freed of all their vicious humours, that, upon repeating the operation for some time, they become perfectly restored."

This cave Kircher visited himself; and found it warm, and every way agreeable to the description given of it. He saw the holes, and heard a murmuring hissing noise in them. Though he missed see-

ing the serpents, it not being the season of their creeping out; yet he saw a great number of their exuviae, or sloughs, and an elm growing hard by laden with them.

Grotto, Grove.

The discovery of this cave was by the cure of a leper going from Rome to some baths near this place. Losing his way, and being benighted, he happened upon this cave. Finding it very warm, he pulled off his clothes; and being weary and sleepy, had the good fortune not to feel the serpents about him till they had wrought his cure.

Museum Worm.

Milky Grotto, Crypta Lactea, a mile distant from the ancient village of Bethlehem, is said to have been thus denominated on occasion of the blessed Virgin, who let fall some drops of milk in giving suck to Jesus in this grotto. And hence it has been commonly supposed, that the earth of this cavern has the virtue of restoring milk to women that are grown dry, and even of curing fevers. Accordingly, they are always digging in it, and the earth is sold at a good rate to such as have faith enough to give credit to the fable. An altar has been built on the place, and a church just by it.

GROTTO, is also used for a little artificial edifice made in a garden, in imitation of a natural grotto. The outsides of these grottoes are usually adorned with rustic architecture, and their inside with shell-work, fossils, &c. finished likewise with jets d'eau or fountains, &c.

A cement for artificial grottoes may be made thus: Take two parts of white rosin, melt it clear, and add to it four parts of bees wax: when melted together, add two or three parts of the powder of the stone you design to cement, or so much as will give the cement the colour of the stone: to this add one part of flower of sulphur: incorporate all together over a gentle fire, and afterwards knead them with your hands in warm water. With this cement the stones, shells, &c. after being well dried before the fire, may be cemented.

Artificial red coral branches, for the embellishment of grottoes, may be made in the following manner: Take clear rosin, dissolve it in a brass-pan; to every ounce of which add two drams of the finest vermilion: when you have stirred them well together, and have chosen your twigs and branches, peeled and dried, take a pencil and paint the branches all over whilst the composition is warm; afterwards shape them in imitation of natural coral. This done, hold the branches over a gentle coal fire, till all is smooth and even as if polished. In the same manner white coral may be prepared with white lead, and black coral with lamp-black.

A grotto may be built with little expence, of glass, cinders, pebbles, pieces of large flint, shells, moss, stones, counterfeit coral, pieces of chalk, &c. all bound or cemented together with the above-described cement.

GROVE, in *Gardening*, a small wood impervious to the rays of the sun.

GROVES have been in all ages held in great veneration. The *proscuchæ*, and high-places of the Jews, whither they resorted for the purposes of devotion, were probably situated in groves: See Joshua xxiv. 26. The *proscuchæ* in Alexandria, mentioned by Philo,

Grove. had groves about them, because he complains that the Alexandrians, in a tumult against the Jews, cut down the trees of their proseuchæ.

The ancient Romans had a sort of groves near several of their temples, which were consecrated to some god, and called *luci*, by antiphrasis, *à non lucendo*, as being shady and dark. The veneration which the ancient druids had for groves is well known.

Modern groves are not only great ornaments to gardens: but are also the greatest relief against the violent heat of the sun, affording shade to walk under in the hottest parts of the day, when the other parts of the garden are useless; so that every garden is defective which has not shade.

Groves are of two sorts, viz. either open or close. Open groves are such as have large shady trees, which stand at such distances, as that their branches approach so near to each other as to prevent the rays of the sun from penetrating through them.

Close groves have frequently large trees standing in them; but the ground under these is filled with shrubs or underwood; so that the walks which are in them are private, and screened from winds: by which means they are rendered agreeable for walking, at those times when the air is either too hot or too cold in the more exposed parts of the garden. These are often contrived so as to bound the open groves, and frequently to hide the walls or other inclosures of the garden: and when they are properly laid out, with dry walks winding through them, and on the sides of these sweet-smelling shrubs and flowers irregularly planted, they have a charming effect.

GROVE, Henry, a learned and ingenious Presbyterian divine, was born at Taunton in Somersetshire, in 1683. Having obtained a sufficient stock of classical literature, he went through a course of academical learning, under the reverend Mr Warren of Taunton, who had a flourishing academy: He then removed to London, and studied some time under the reverend Mr Rowe, to whom he was nearly related. Here he contracted a friendship with several persons of merit, and particularly with Dr Watts, which continued till his death, though they were of different opinions in several points warmly controverted among divines. After two years spent under Mr Rowe, he returned into the country, and began to preach with great reputation; when an exact judgment, a lively imagination, and a rational and amiable representation of Christianity, delivered in a sweet and well-governed voice, rendered him generally admired; and the spirit of devotion which prevailed in his sermons procured him the esteem and friendship of Mrs Singer, afterwards Mrs Rowe, which she expressed in a fine ode on death, addressed to Mr Grove. Soon after his beginning to preach, he married; and on the death of Mr Warren, was chosen to succeed him in the academy at Taunton. This obliging him to reside there, he preached for 18 years to two small congregations in the neighbourhood; and though his salary from both was less than twenty pounds a-year, and he had a growing family, he went through it cheerfully. In 1708, he published a piece, entitled, *The Regulations of Diversions*, drawn up for the use of his pupils. About the same time, he entered into a private dispute by letter with Dr Samuel Clarke: but they not being able to con-

vince each other, the debate was dropped with expressions of great mutual esteem. He next wrote several papers printed in the *Spectator*, viz. Numbers 588. 601. 626. 635. The last was republished, by the direction of Dr Gibson bishop of London, in the *Evidences of the Christian Religion*, by Joseph Addison, Esq. In 1725, Mr James, his partner in the academy, dying, he succeeded him in his pastoral charge at Fulwood, near Taunton, and engaged his nephew to undertake the other parts of Mr James's work as tutor; and in this situation Mr Grove continued till his death, which happened in 1738. His great concern with his pupils, was to inspire and cherish in them a prevailing love of truth, virtue, liberty, and genuine religion, without violent attachments or prejudices in favour of any party of Christians. He represented truth and virtue in a most engaging light; and though his income, both as a tutor and a minister, was insufficient to support his family without breaking into his paternal estate, he knew not how to refuse the call of charity. Besides the above pieces, he wrote, 1. An Essay towards a demonstration of the Soul's Immortality. 2. An Essay on the Terms of Christian Communion. 3. The Evidence of our Saviour's Resurrection considered. 4. Some Thoughts concerning the Proof of a Future State from Reason. 5. A Discourse concerning the Nature and Design of the Lord's Supper. 6. Wisdom the first spring of Action in the Deity. 7. A Discourse on Saving Faith. 8. Miscellanies in prose and verse. 9. Many Sermons, &c. After his decease, his posthumous works were published by subscription, in four volumes octavo, with the names of near 700 subscribers, among whom were some of the best judges of merit in the established church.

GROUND, in painting, the surface upon which the figures and other objects are represented.

The ground is properly understood of such parts of the piece as have nothing painted on them, but retain the original colour upon which the other colours are applied to make the representations.

A building is said to serve as a ground to a figure when the figure is painted on the building.

The ground behind a picture in miniature is commonly blue or crimson, imitating a curtain of satin or velvet.

GROUND, in etching, denotes a gummy composition smeared over the surface of the metal to be etched, to prevent the aquafortis from eating, except in such places where this ground is cut through with the point of a needle. See **ETCHING**.

GROUND-Angling, fishing under water without a float, only with a plumb of lead, or a bullet, placed about nine inches from the hook; which is better, because it will roll on the ground. This method of fishing is most proper in cold weather, when the fish swim very low.

The morning and evening are the chief seasons for the ground line in fishing for trout; but if the day prove cloudy, or the water muddy, you may fish at ground all day.

GROUND-Tackle, a ship's anchors, cables, &c. and in general whatever is necessary to make her ride safe at anchor.

GROUND-Ivy. See **GLECHOMA**, **BOTANY Index**.

GROUND

Grove.
Ground.

GROUND-Pine. See **TEUCRIUM**, **BOTANY Index.**

GROUNDSEL. See **SENECIO**, **BOTANY Index.**

GROUP, in painting and sculpture, is an assemblage of two or more figures of men, beasts, fruits, or the like, which have some apparent relation to each other. See **PAINTING**. The word is formed of the Italian *gruppo*, a *knot*.

The **GROUPS**, a cluster of islands lately discovered in the South sea. They lie in about S. Lat. 18. 12. and W. Long. 142. 42. They are long narrow slips of land, ranging in all directions, some of them ten miles or upwards in length; but not more than a quarter of a mile broad. They abound in trees, particularly those of the cocoa nut. They are inhabited by well made people, of a brown complexion. Most of them carried in their hands a slender pole about 14 feet in length, pointed like a spear; they had likewise something shaped like a paddle, about four feet long. Their canoes were of different sizes, carrying from three to six or seven people, and some of them hoisted a sail.

GROUSE, or **GROWSE**, *Moor-fowl*, or *Moor-game*. See **TETRAO**, **ORNITHOLOGY Index.**

GROUTHEAD, or **GREATHEAD**, **ROBERT**, a learned and famous bishop of Lincoln, was born at Stow in Lincolnshire, or (according to others) at Stradbrook in Suffolk, in the latter part of the twelfth century. His parents were so poor, that when a boy he was reduced to do the meanest offices, and even to beg his bread; till the mayor of Lincoln, struck with his appearance and the quickness of his answers to certain questions, took him into his family, and put him to school. Here his ardent love of learning, and admirable capacity for acquiring it, soon appeared, and procured him many patrons, by whose assistance he was enabled to prosecute his studies, first at Cambridge, afterwards at Oxford, and at last at Paris. In these three famous seats of learning, he spent many years in the most indefatigable pursuit of knowledge, and became one of the best and most universal scholars of the age. He was a great master not only of the French and Latin, but also of the Greek and Hebrew languages, which was a very rare accomplishment in those times. We are assured by Roger Bacon, who was intimately acquainted with him, that he spent much of his time for almost forty years in the study of geometry, astronomy, optics, and other branches of physical and mathematical learning, in all which he very much excelled. Theology was his favourite study, in which he read lectures at Oxford with great applause. In the mean time, he obtained several preferments in the church, and was at length elected and consecrated bishop of Lincoln, A. D. 1235. In this station he soon became very famous, by the purity of his manners, the popularity of his preaching, the vigour of his discipline, and the boldness with which he reprov'd the vices and opposed the arbitrary mandates of the court of Rome; of this last it may be proper to give one example. Pope Innocent IV. had granted to one of his own nephews named *Frederick*, who was but a child, a provision to the first canon's place in the church of Lincoln that should become vacant; and sent a bull to the archbishop of Canterbury, and Innocent, then papal legate in England, commanding them to see the provision

made effectual; which they transmitted to the bishop **GROUTHEAD** of Lincoln. But that brave and virtuous prelate boldly refused to obey this unreasonable mandate, and sent an answer to the papal bull containing the following severe reproaches against his holiness for abusing his power: "If we except the sins of Lucifer and Antichrist, there neither is nor can be a greater crime, nor any thing more contrary to the doctrine of the gospel, or more odious and abominable in the sight of Jesus Christ, than to ruin and destroy the souls of men, by depriving them of the spiritual aid and ministry of their pastors. This crime is committed by those who command the benefices intended for the support of able pastors, to be bestowed on those who are incapable of performing the duties of the pastoral office. It is impossible therefore that the holy apostolic see, which received its authority from the Lord Jesus Christ, for edification, and not for destruction, can be guilty of such a crime, or any thing approaching to such a crime, so hateful to God and so hurtful to men. For this would be a most manifest corruption and abuse of its authority, which would forfeit all its glory, and plunge it into the pains of hell." Upon hearing this letter, his holiness became frantic with rage, poured forth a torrent of abuse against the good bishop, and threatened to make him an object of terror and astonishment to the whole world. "How dare (said he) this old, deaf, doating fool, disobey my commands? Is not his master the king of England my subject, or rather my slave? Cannot he cast him into prison, and crush him in a moment?" But the cardinals by degrees brought the pope to think more calmly, and to take no notice of this letter. "Let us not (said they) raise a tumult in the church without necessity, and precipitate that revolt and separation from us, which we know must one day take place." Remarkable words, when we reflect when and by whom they were spoken! The bishop did not long survive this noble stand against the gross corruptions and tyranny of the church of Rome? for he fell sick at his castle of Bugden that same year; and when he became sensible that his death was drawing near, he called his clergy into his apartment, and made a long discourse to them, to prove that the reigning pope Innocent IV. was Antichrist. With this exertion his strength and spirits were so much exhausted, that he expired soon after, October 9. 1253. A contemporary historian, who was perfectly well acquainted with him, hath drawn his character in the following manner. "He was a free and bold reprimander of the pope and the king; an admonisher of the prelates; a corrector of the monks; an instructor of the clergy; a supporter of the studious; a censurer of the incontinent; a scourge and terror to the court of Rome; a diligent searcher of the scripture; and a frequent preacher to the people. At his table he was hospitable, polite, and cheerful. In the church he was contrite, devout, and solemn; and in performing all the duties of his office he was venerable, active, and indefatigable." The illustrious Roger Bacon, who was most capable, and had the best opportunities of forming a true judgment of the extent of his learning, by perusing his works, and by frequently conversing with him, hath given this honourable testimony in his favour. "Robert GROUTHEAD bishop

Growth, Growth, bishop of Lincoln, and his friend Friar Adam de Marisco, are the two most learned men in the world, and excel all the rest of mankind both in divine and human knowledge." This most excellent and learned prelate was a very voluminous writer, and composed a prodigious number of treatises on a great variety of subjects in philosophy and divinity, a catalogue of which is given by Bale.

GROWTH, the gradual increase of bulk and stature that takes place in animals or vegetables, to a certain period.—The increase of bulk in such bodies as have no life, owing to fermentations excited in their substance, or to other causes, is called **EXPANSION**, **SWELLING**, &c.

The growth of animals, nay even of the human species, is subject to great variations. A remarkable instance in the last was observed in France in the year 1729. At this time the Academy of Sciences examined a boy who was then only seven years old, and who measured four feet eight inches and four lines high without his shoes. His mother observed the signs of puberty on him at two years old, which continued to increase very quick, and soon arrived at the usual standard. At four years old he was able to lift and toss the common bundles of hay in stables into the horses racks; and at six years old could lift as much as a sturdy fellow of twenty. But though he thus increased in bodily strength, his understanding was no greater than is usual with children of his age, and their play-things were also his favourite amusements.

Another boy, a native of the hamlet of Bouzanquet, in the diocese of Alais, though of a strong constitution, appeared to be knit and stiff in his joints till he was about four years and a half old. During this time nothing farther was remarkable of him than an extraordinary appetite, which was satisfied no otherwise than by giving him plenty of the common aliments of the inhabitants of the country, consisting of rye-bread, chesnuts, bacon, and water; but his limbs soon becoming supple and pliable, and his body beginning to expand itself, he grew up in so extraordinary a manner, that at the age of five years he measured four feet three inches; some months after, he was four feet eleven inches; and at six, five feet, and bulky in proportion. His growth was so rapid, that one might fancy he saw him grow: every month his clothes required to be made longer and wider; and what was still very extraordinary in his growth, it was not preceded by any sickness, nor accompanied with any pain in the groin or elsewhere. At the age of five years his voice changed, his beard began to appear, and at six he had as much as a man of thirty; in short, all the unquestionable marks of puberty were visible in him. It was not doubted in the country but this child was, at five years old, or five and a half, in a condition of begetting other children; which induced the rector of the parish to recommend to his mother that she would keep him from too familiar a conversation with children of the other sex. Though his wit was riper than is commonly observable at the age of five or six years, yet its progress was not in proportion to that of his body. His air and manner still retained something childish, though by his bulk and stature he resembled a complete man, which at first sight produced a very

singular contrast. His voice was strong and manly, and his great strength rendered him already fit for the labours of the country. At the age of five years, he could carry to a good distance three measures of rye, weighing 84 pounds; when turned of six, he could lift up easily on his shoulders and carry loads of 150 pounds weight a good way off: and these exercises were exhibited by him as often as the curious engaged him thereto by some liberality. Such beginnings made people think that he would soon shoot up into a giant. A mountebank was already soliciting his parents for him, and flattering them with hopes of putting him in a way of making a great fortune. But all these hopes suddenly vanished. His legs became crooked, his body shrunk, his strength diminished, his voice grew sensibly weaker, and he at last sunk into a total imbecility.

In the Paris Memoirs also there is an account of a girl who had her menses at three months of age. When four years old, she was four feet six inches in height, and had her limbs well proportioned to that height, her breasts large and plump, and the parts of generation like those of a girl of eighteen; so that there is no doubt but that she was marriageable at that time, and capable of being a mother of children. These things are more singular and marvellous in the northern than in the southern climates, where the females come sooner to maturity. In some places of the East Indies, the girls have children at nine years of age.

Many other instances of extraordinary growth might be brought, but the particulars are not remarkably different from those already related.—It is at first sight astonishing that children of such early and prodigious growth do not become giants: but when we consider, that the signs of puberty appear so much sooner than they ought, it seems evident that the whole is only a more than usually rapid expansion of the parts, as in hot climates; and accordingly it is observed, that such children, instead of becoming giants, always decay and die apparently of old age, long before the natural term of human life.

GRUB, in *Zoology*, the English name of the hexapode worms, produced from the eggs of beetles, and which at length are transformed into winged insects of the same species with their parents.

GRUBBING, in *Agriculture*, the digging or pulling up of the stubs and roots of trees. When the roots are large, this is a laborious task: but Mr Mortimer hath shown how it may be accomplished in such a manner as to save great expence by a very simple and easy method. He proposes a strong iron hook to be made about two feet four inches long, with a large iron ring fastened to the upper part of it. This hook must be fastened in a hole in the side of the root; and a lever being put into the ring, three men, by means of this lever, may wring out the root, and twist the sap-roots asunder. Stubs of trees may also be taken up with the same hook, in which work it will save a great deal of labour, though not so much as in the other; because the stubs must be first cleft with wedges, before the hook can enter their sides, to wrench them out by pieces.

GRUBENHAGEN, a town and castle of Westphalia, situated in the principality of the same name.

GRUBENHAGEN,

GRUBENTHAGEN, a principality in the duchy of Brunswic, in Lower Saxony, remarkable for its mines of silver, copper, iron, and lead. The Hartz forest, the ancient *Hercynian*, is a mountain covered with trees and abounding with mines.

GRUINALES (from *grus*, "a crane"), the name of the fourteenth order in Linnæus's Fragments of a Natural Method, consisting of geranium, and other genera allied to it in habit and structure.

GRUME, in *Medicine*, denotes a concremented clot of blood, milk, or other substance. Hence grumous blood is that which approaches to the nature of grume.

GRUPPO, or *Turned SHAKE*, a musical grace, defined by Playford to consist in the alternate prolation of two tones in juxtaposition to each other, with a close on the note immediately beneath the lower of them. See **SHAKE**.

GRUS, in antiquity, a dance performed yearly by the young Athenians around the temple of Apollo, on the day of the *Desia*. The motions and figures of this dance were very intricate, and variously interwoven; some of them being intended to express the windings of the labyrinth wherein the minotaur was killed by Theseus.

GRUS, in *Astronomy*, a southern constellation, not visible in our latitude. The number of stars in this constellation, according to Mr Sharp's Catalogue, is 13.

GRUS. See **ARDEA**, **ORNITHOLOGY Index**.

GRUTER, JAMES, a learned philologer, and one of the most laborious writers of his time, was born at Antwerp in 1560. He was but a child when his father and mother, being persecuted for the Protestant religion by the duchess of Parma, governess of the Netherlands, carried him into England. He imbibed the elements of learning from his mother, who was one of the most learned women of the age, and besides French, Italian, and English, was a complete mistress of Latin, and well skilled in Greek. He spent some years in the university of Cambridge; after which he went to that of Leyden to study the civil law; but at last applied himself wholly to polite literature. After travelling much, he became professor in the university of Heidelberg; near which city he died in 1627. He wrote many works; the most considerable of which are, 1. A large collection of ancient inscriptions. 2. *Thesaurus cræticus*. 3. *Deliciae poetarum Gallorum, Italorum, et Belgarum, &c.*

GRUYERES, a town of Switzerland, in the canton of Friburgh, with a castle. It is famous for its cheese, which bears the same name. E. Long. 6. 53. N. Lat. 46. 35.

GRY, a measure containing one-tenth of a line.

A line is one-tenth of a digit, and a digit one-tenth of a foot, and a philosophical foot one-third of a pendulum, whose diadromes, or vibrations, in the latitude of 45 degrees, are each equal to one-second of time, or one-sixtieth of a minute.

GRYLLUS, a genus of insects belonging to the order *Hemiptera*. See **ENTOMOLOGY Index**.

GRYPHITES, CROW'S STONE, an old name for a mineral found in clay and gravel pits.

GUADALAJARA, or **GUADALAXARA**, a town of Spain, in New Castile, seated on the river Henares.

It has a linen manufacture, and contains 12,000 inhabitants. W. Long. 2. 47. N. Lat. 40. 36.

GUADALAJARA, a considerable town of Mexico, and capital of a rich and fertile province of the same name, with a bishop's see. W. Long. 104. 16. N. Lat. 21. 10.

GUADALAVIAR, a river of Spain, which rises on the confines of Arragon and New Castile, and, running by Turvel in Arragon, crosses the kingdom of Valencia, passes by the town of the same name, and soon after falls into the Mediterranean sea, a little below Valencia.

GUADALQUIVER, one of the most famous rivers of Spain, rises in Andalusia, near the confines of Granada, and running quite through Andalusia, by the towns of Baiza, Andaxar, Cordova, Seville, and St Lucar, falls at last into the bay of Cadiz.

GUADALUPE, a handsome town in Spain, in Estramadura, with a celebrated convent, whose structure is magnificent, and is immensely rich. It is seated on a rivulet of the same name; 45 miles south-west from Toledo. W. Long. 4. 45. N. Lat. 39. 12.

GUADALUPE, one of the Caribbee islands, belonging to the French, the middle of which is seated about N. Lat. 16. 30. W. Long. 61. 50.

This island, which is of an irregular figure, may be about 80 leagues in circumference. It is divided into two parts by a small arm of the sea, which is not above two leagues long, and from 15 to 40 fathoms broad. This canal, known by the name of the *Salt River*, is navigable, but will only carry vessels of 50 tons burden.

That part of the island which gives its name to the whole colony is, towards the centre, full of craggy rocks, where the cold is so intense, that nothing will grow upon them but fern, and some useless shrubs covered with moss. On the top of these rocks, a mountain called *la Souphriere*, or the *Brimstone Mountain*, rises to an immense height. It exhales, through various openings, a thick black smoke, intermixed with sparks that are visible by night. From all these hills flow numberless springs, which fertilize the plains below, and moderate the burning heat of the climate by a refreshing stream, so celebrated that the galleons which formerly used to touch at the Windward islands, had orders to renew their provision with this pure and salubrious water. Such is that part of the island properly called *Guadalupe*. That which is commonly called *Grand Terre*, has not been so much favoured by nature. It is indeed less rugged; but it wants springs and rivers. The soil is not so fertile, or the climate so wholesome or so pleasant.

No European nation had yet taken possession of this island, when 550 Frenchmen, led on by two gentlemen named *Loline* and *Duplessis*, arrived there from Dieppe on the 28th of June 1635. They had been very imprudent in their preparations. Their provisions were so ill chosen, that they were spoiled in the passage, and they had shipped so few, that they were exhausted in two months. They were supplied with more from the mother-country. St Christopher's, whether from scarcity or design, refused to spare them any; and the first attempts in husbandry they made in the country could not as yet afford any thing. No resource was left for

Guadaloupe, the colony but from the savages; but the superfluities of a people, who cultivate but little, and therefore had never laid up any stores, could not be very considerable. The new comers, not content with what the savages might freely and voluntarily bring, came to a resolution to plunder them; and hostilities commenced on the 16th of January 1636.

The Caribs, not thinking themselves in a condition openly to resist an enemy who had so much the advantage from the superiority of their arms, destroyed their own provisions and plantations, and retired to Grande Terre, or to the neighbouring islands. From thence the most desperate came over to the island from which they had been driven, and concealed themselves in the thickest parts of the forests. In the day-time, they shot with their poisoned arrows, or knocked down with their clubs, all the Frenchmen who were scattered about for hunting or fishing. In the night, they burned the houses and destroyed the plantations of their unjust spoilers.

A dreadful famine was the consequence of this kind of war. The colonists were reduced to graze in the fields, to eat their own excrements, and to dig up dead bodies for their subsistence. Many who had been slaves at Algiers, held in abhorrence the hands that had broken their fetters: and all of them cursed their existence. It was in this manner that they atoned for the crime of their invasion, till the government of Aubert brought a peace with the savages at the end of the year 1640. The remembrance, however, of hardships endured in an invaded island, proved a powerful incitement to the cultivation of all articles of immediate necessity; which afterwards induced an attention to those of luxury consumed in the mother-country. The few inhabitants who had escaped the calamities they had drawn upon themselves, were soon joined by some discontented colonists from St Christopher's, by Europeans fond of novelty, by sailors tired of navigation, and by some sea-captains, who prudently chose to commit to the care of a grateful soil the treasures they had saved from the dangers of the sea. But still the prosperity of Guadaloupe was stopped or impeded by obstacles arising from its situation.

The facility with which the pirates from the neighbouring islands could carry off their cattle, their slaves, their very crops, frequently brought them into a desperate situation. Intestine broils, arising from jealousies of authority, often disturbed the quiet of the planters. The adventurers who went over to the Windward islands, disdain a land that was fitter for agriculture than for naval expeditions, were easily drawn to Martinico by the convenient roads it abounds with. The protection of those intrepid pirates brought to that island all the traders who flattered themselves that they might buy up the spoils of the enemy at a low price, and all the planters who thought they might safely give themselves up to peaceful labours. This quick population could not fail of introducing the civil and military government of the Caribbee islands into Martinico. From that time the French ministry attended more seriously to this than to the other colonies, which were not so immediately under their direction; and hearing chiefly of this island, they turned all their encouragements that way.

It was in consequence of this preference, that in

1700 the number of inhabitants in Guadaloupe amount-Guadaloupe ed only to 3825 white people, 325 savages, free negroes, mulattoes, and 6725 slaves, many of whom were Cariba.

At the end of the year 1755, the colony was peopled with 9643 whites, 41,140 slaves of all ages and of both sexes. Her saleable commodities were the produce of 330 sugar-plantations, and 15 plots of indigo; besides cocoa, coffee, and cotton. Such was the state of Guadaloupe when it was conquered by the British in the month of April 1759.

France lamented this loss; but the colony had reason to comfort themselves for this disgrace. During a siege of three months, they had seen their plantations destroyed, the buildings that served to carry on their works burnt down, and some of their slaves carried off. Had the enemy been forced to retreat after all these devastations, the island was ruined. Deprived of all assistance from the mother-country, which was not able to send her any succours; and expecting nothing from the Dutch (who, on account of their neutrality, came into her roads), because she had nothing to offer them in exchange; she could never have subsisted till the ensuing harvest.

The conquerors delivered them from these apprehensions. The British, indeed, are no merchants in their colonies. The proprietors of lands, who mostly reside in Europe, send to their representatives whatever they want, and draw the whole produce of the estate by the return of their ship. An agent settled in some sea-port of Great Britain is intrusted with the furnishing the plantation and receiving the produce. This was impracticable at Guadaloupe; and the conquerors in this respect were obliged to adopt the custom of the conquered. The British, informed of the advantage the French made of their trade with the colonies, hastened, in imitation of them, to send their ships to the conquered island; and so multiplied their expeditions, that they overstocked the market, and sunk the price of all European commodities. The colonists bought them at a very low price; and, in consequence of this plenty, obtained long delays for the payment.

To this credit, which was necessary, was soon added another arising from speculation, which enabled the colony to fulfil its engagements. A great number of negroes were carried thither, to hasten the growth and enhance the value of the plantations. It has been said in various memorials, all copied from each other, that the English had stocked Guadaloupe with 30,000 during the four years and three months that they remained masters of the island. The registers of the custom-houses, which may be depended on, as there could be no inducement for an imposition, attest that the number was no more than 18,721. This was sufficient to give the nation well-grounded hopes of reaping great advantages from their new conquest. But their hopes were frustrated; and the colony, with its dependencies, was restored to its former possessors by the treaty of peace in July 1763.

By the survey taken in 1767, this island, including the smaller islands, Desceada, St Bartholomew, Mari-galante, and the Saints, dependent upon it, contains 11,863 white people of all ages and of both sexes, 752 free blacks and mulattoes, 72,761 slaves; which makes in all a population of 85,376 souls.

Guadalupe
Gualeor.

Guadalupe was taken by the British in 1794, but retaken by the French the following year. It was again reduced by the British in 1810, and remained in their possession till the general peace in 1814, when it was restored to France. In 1812, according to an official return, the population consisted of 12,747 whites, 94,328 slaves, and 7764 free negroes. Guadalupe exported 8,216,249 pounds of sugar in 1811, with 1,601,686 pounds of coffee, besides other articles.

GUADIANA, a large river in Spain, having its source in New Castile, and crossing the high mountains, falls down to the lakes called *Ojos of Guadiana*; from whence it runs to Calatrava, Medelin, Merida, and Badajoz in Estremadura of Spain; and after having run for some time in Alentejo in Portugal, it passes on to separate the kingdom of Algarve from Andalusia; and falls into the bay or gulf of Cadiz, between Castro Marino and Agramonte. W. Long. 7. 26. N. Lat. 37. 10.

GUADIX, a town of Spain, in the kingdom of Granada, with a bishop's see. It was taken from the Moors in 1253, who afterwards retook it, but the Spaniards again got possession of it in 1489. It is seated in a fertile country, in W. Long. 3. 9. N. Lat. 37. 24.

GUAJACUM, LIGNUM VITÆ, or *Pockwood*; a genus of plants belonging to the decandria class; and in the natural method ranking under the 14th order, *Gruinales*. See BOTANY and MATERIA MEDICA *Index*.

GUALEOR, GUALIOR, or *Gowalier*, a large town of Indostan in Asia, and capital of a province of the same name, with an ancient and celebrated fortress of great strength. It is situated in the very heart of Hindostan Proper, being about 80 miles to the south of Agra, the ancient capital of the empire, and 130 from the nearest part of the Ganges. From Calcutta it is, by the nearest route, upwards of 800 miles, and 910 by the ordinary one; and about 280 from the British frontiers. Its latitude is 26. 14. and longitude 78. 26. from Greenwich.

In the ancient division of the empire it is classed in the soubah of Agra, and is often mentioned in history. In the year 1008, and during the two following centuries, it was thrice reduced by famine. It is probable that it must in all ages have been deemed a military post of the utmost consequence, both from its situation in respect to the capital, and from the peculiarity of its site, which was generally deemed impregnable. With respect to its relative position, it must be considered that it stands on the principal road leading from Agra to Malwa, Guzerat, and the Decan: and that too, near the place where it enters the hilly tract which advances from Bundelcund, Malwa, and Agimere, to a parallel with the river Jumnah, throughout the greatest part of its course. And from all these circumstances of general and particular situation, together with its natural and acquired advantages as a fortress, the possession of it was deemed as necessary to the ruling emperors of Hindostan as Dover castle might have been to the Saxon and Norman kings of England.—Its palace was used as a state prison as early as 1317, and continued to be such until the downfall of the empire.—On the final dismemberment of the empire, Gualeor appears to have fallen to the lot of a rajah of the Jat tribe; who assumed the government of the district in which it is

VOL. X. Part I.

immediately situated, under the title of Rana of Gobud or Gohd. Since that period it has changed masters more than once; the Mahrattas, whose dominions extend to the neighbourhood of it, having sometimes possessed it, and at other times the Rana: but the means of transfer were always either famine or treachery, nothing like a siege having ever been attempted.

Gualeor was in the possession of Madajee Scindia, a Mahratta chief, in 1779, at the close of which year the council-general of Bengal concluded an alliance with the Rana; in consequence of which four battalions of sepoy of 500 men each, and some pieces of artillery, were sent to his assistance, his district being overrun by the Mahrattas, and himself almost shut up in his fort of Gobud. The grand object of this alliance was to penetrate into Scindia's country, and finally to draw Scindia himself from the western side of India, where he was attending the motions of General Goddard, who was then employed in the reduction of Guzerat; it being Mr Hastings's idea, that when Scindia found his own dominions in danger, he would detach himself from the confederacy, of which he was the principal member, and thus leave matters open for an accommodation with the court of Poonah. It fell out exactly as Mr Hastings predicted. Major William Popham was appointed to the command of the little army sent to the Rana's assistance; and was very successful, as well in clearing his country of the enemy, as in driving them out of one of their own most valuable districts, and keeping possession of it: and Mr Hastings, who justly concluded that the capture of Gualeor, if practicable, would not only open the way into Scindia's country, but would also add to the reputation of our arms in a degree much beyond the risk and expence of the undertaking, repeatedly expressed his opinion to Major Popham, together with a wish that it might be attempted; and founding his hopes of success on the confidence that the garrison would probably have in the natural strength of the place. It was accordingly undertaken; and the following account of the place, and the manner of our getting possession of it, was written by Captain Jonathan Scott, at that time Persian interpreter to Major Popham, to his brother Major John Scott.

"The fortress of Gualeor stands on a vast rock of about four miles in length, but narrow, and of unequal breadth, and nearly flat at the top. The sides are so steep as to appear almost perpendicular in every part; for where it was not naturally so, it has been scraped away; and the height from the plain below is from 200 to 300 feet. The rampart conforms to the edge of the precipice all round; and the only entrance to it is by steps running up the side of the rock, defended on the side next the country by a wall and bastions, and farther guarded by seven stone gateways, at certain distances from each other. The area within is full of noble buildings, reservoirs of water, wells, and cultivated land; so that it is really a little district in itself. At the north-west foot of the mountain is the town, pretty large, and well built; the houses all of stone. To have besieged this place would be vain, for nothing but a surprise or blockade could have carried it.

"A tribe of banditti from the district of the Rana

Q

had

Gualeor. had been accustomed to rob about this town, and once in the dead of night had climbed up the rock and got into the fort. This intelligence they had communicated to the Rana, who often thought of availing himself of it, but was fearful of undertaking an enterprise of such moment with his own troops. At length he informed Major Popham of it, who sent a party of the robbers to conduct some of his own spies to the spot. They accordingly climbed up in the night, and found that the guards generally went to sleep after their rounds. Popham now ordered ladders to be made; but with so much secrecy, that until the night of surprise only myself and a few others knew it. On the 3d of August, in the evening, a party was ordered to be in readiness to march under the command of Captain William Bruce; and Popham put himself at the head of two battalions, which were immediately to follow the storming party. To prevent as much as possible any noise in approaching or ascending the rock, a kind of shoes of woollen cloth were made for the sepoy, and stuffed with cotton. At 11 o'clock the whole detachment marched from the camp at Reypour, eight miles from Gualeor, through unfrequented paths, and reached it at a little before day-break. Just as Captain Bruce arrived at the foot of the rock, he saw the lights which accompanied the rounds moving along the ramparts, and heard the sentinels cough (the mode of signifying that all is well in an Indian camp or garrison), which might have damped the spirit of many men, but served only to inspire him with more confidence, as the moment for action, that is, the interval between the passing the rounds was now ascertained. Accordingly when the lights were gone, the wooden ladders were placed against the rock, and one of the robbers first mounted, and returned with an account that the guard was retired to sleep. Lieutenant Cameron, our engineer, next mounted, and tied a rope-ladder to the battlements of the wall; this kind of ladder being the only one adapted to the purpose of scaling the wall is a body (the wooden ones only serving to ascend from crag to crag of the rock, and to assist in fixing the rope-ladders). When all was ready, Captain Bruce with 20 sepoy, grenadiers, ascended without being discovered, and squatted down under the parapet; but before a reinforcement arrived, three of the party had so little recollection as to fire on some of the garrison who happened to be lying asleep near them. This had nearly ruined the whole plan: the garrison were of course alarmed, and ran in great numbers towards the place; but ignorant of the strength of the assailants (as the men fired on had been killed outright), they suffered themselves to be stopped by the warm fire kept up by the small party of the grenadiers, until Major Popham himself, with a considerable reinforcement, came to their aid. The garrison then retreated to the inner buildings, and discharged a few rockets, but soon afterwards retreated precipitately through the gate; whilst the principal officers, thus deserted, assembled together in one house, and hung out a flag. Major Popham sent an officer to give them assurance of quarter and protection; and thus, in the space of two hours, this important and astonishing fortress was completely in our possession. We had only 20 men wounded and one killed. On the side of the enemy, Bapogee

the governor was killed, and most of the principal officers wounded."

Thus fell the strongest fortress in Hindostan, garrisoned by a chosen body of 1200 men, on August 4. 1780; and which, before the capture of it by the British, was pronounced by the princes of Hindostan, as far as their knowledge in the military art extended, to be impregnable. In 1783 Madajee Scindia besieged this fortress, then possessed by the Rana of Gohud, with an army of 70,000 men, and effected the reduction by the treachery of one of the Rana's officers. During the war in 1804, it surrendered to the British by capitulation after a short siege, but was restored to the Mahrattas at the peace by Lord Cornwallis.

GUAM, the largest of the Ladrone islands in the South sea, being about 40 leagues in circumference. It is the only one among the innumerable islands that lie scattered in the immense South sea which has a town built in the European style, with a regular fort, a church, and civilized inhabitants. The air is excellent, the water good, the garden stuffs and fruits are exquisite, the flocks of buffaloes innumerable, as are those of goats and hogs, and all kinds of poultry abound in an astonishing degree. There is no port in which worn-out sailors can be more speedily restored, or find better or more plentiful refreshments, than in this.

But Guam did not formerly enjoy this state of abundance. When it was first discovered by Magellan in 1521, with the other eight principal islands that lie north of it, which, with a multitude of smaller ones, form together that archipelago known by the name of the Ladrone, they were all crowded with inhabitants, but afforded no refreshments to navigators except fish, bananas, cocoa nuts, and bread fruit; and even these could not be procured but by force, amidst showers of the arrows and lances of the natives. The Spaniards carried thither from America the first stock of cattle, of fowls, of plants, and seeds, and fruits, as well as garden stuffs, which are all now found in such abundance.

The Ladrone islands, and Guam in particular, were covered with inhabitants when they were discovered. It is said that Guam alone contained upon its coast more than 30,000 people. These men were ferocious savages and bold thieves, as all the islanders in the South seas are, undoubtedly because they were unacquainted with the rights of property; but they were so savage, so incapable of supporting the yoke of civilization, that the Spaniards, who undertook to bring them under the regulations of law and order, have seen their numbers almost annihilated within the space of two centuries. Under the government of their missionaries, these fierce islanders, after having long defended, by cruel wars, the right of living like wild beasts under the guidance of instinct, being at last obliged to yield to the superiority of the Spanish arms, gave themselves up to despair: they took the resolution of administering potions to their women, in order to procure abortions, and to render them sterile, that they might not bring into the world, and leave behind them, beings that were not free, according to the ideas that they had of liberty. A resolution so violent,

**Gualeor,
Guam.**

Guam. lent, and so contrary to the views and intentions of nature, was persisted in with so much obstinacy in the nine Ladrone islands, that their population, which at the time of the discovery consisted of more than 60,000 souls, does not now exceed 800 or 900 in the whole extent of the archipelago. About 20 or 30 years ago, the scattered fragments of the original natives were collected and established in the island of Guam, where they now begin to recover by the wise precautions, and prudent, though tardy, exertions of a government more adapted to the climate of these islands and to the genius of their inhabitants.

The principal settlement, which the Spaniards call the town of Agana, is situated about four leagues north-east of the landing-place, on the sea-shore, and at the foot of some hills, not very high, in a beautiful well-watered country. Besides this, there are 21 smaller settlements of Indians round the island, all on the sea-shore, composed of five or six families, who cultivate fruits and grain, and employ themselves in fishing.

The centre of the island is still uncleared. The trees are not very tall, but they are fit for the building of houses and of boats. The forests are in general very thick. The Spaniards at first cleared certain portions of land to turn them into savannahs for the feeding of cattle. The formation of savannahs consists in multiplying within the forests small cleared spots separated only by thickets and rows of trees, and kept clean from shrubs of every kind. The Spaniards sow these spots with grass seeds, and other indigenous plants that are fit for pasturage. These meadows, being effectually shaded on every quarter, preserve their freshness, and afford the flocks and herds a shelter from the sun and the great heat of noon. The cattle that were formerly brought to the savannahs of Guam from America have multiplied astonishingly: they are become wild, and must be shot when wanted, or taken by stratagem.

The woods are likewise full of goats, of hogs, and fowls, which were all originally brought thither by the Spaniards, and are now wild. The flesh of all these animals is excellent. In the savannahs, and even in the heart of the forests, there is a vast multitude of pigeons, of parroquets, of thrushes, and of black-birds.

Among the indigenous trees of the country, the most remarkable are, the cocoa-nut tree and the bread-fruit tree. The woods are also filled with guavas, bananas, or plantains of many varieties, citrons, lemons, and oranges, both sweet and bitter, and the small dwarf thorny china-orange with red fruit. The caper-bush abounds in all the Ladrone islands; and as it is constantly in flower, as well as the citron and orange shrubs, with many other of the indigenous plants, they perfume the air with the most agreeable smells, and delight the eye with the richest colours.

The rivers of Guam, which are either rivulets or torrents, abound in fish of an excellent quality: the Indians, however, eat none of them, but prefer the inhabitants of the sea. The turtle, which grow here as large as those in the island of Ascension, are not eaten either by the Indians or Spaniards.

The cultivated crops lately introduced are, the rice, the maize, the indigo, the cotton, the cocoa, the su-

gar-cane, which have all succeeded. That of the maize, especially, is of astonishing fertility: it is common to find in the fields where this grain is cultivated plants of twelve feet high, bearing eight or ten spikes from nine to ten inches in length, set round with well-filled seeds. The gardens are stored with mangoes and pine-apples. The former is one of the finest fruits imaginable: it was brought from Manilla, and may be eaten in great quantity without any bad consequences.—Horses have been brought to Guam from Manilla, and asses and mules from Acapulco. The Indians have been taught to tame and domesticate the ox, and to employ him in the draught.

This island, the land of which rises gradually from the sea-shore towards the centre by a gentle acclivity, is not very mountainous. The inhabitants say, that its soil is equally rich and fertile over the whole island, except in the northern part, which forms a peninsula almost destitute of water. But in the rest, you cannot go a league without meeting a rivulet. Upon penetrating a little way into the interior part of the country, to the east and the south of Agana, many springs of fine water are found, forming, at little distances, basins of pure water, which, being shaded by thick trees, preserve a most agreeable coolness in spite of the heat of the climate.

The indigenous inhabitants are such as they were described by Magellan; of small stature, sufficiently ugly, black, and in general dirty, though they are continually in the water. The women are for the most part handsome, well made, and of a reddish colour. Both sexes have long hair. This scanty people have become by civilization, gentle, honest, and hospitable. They have, however, at the same time acquired a vice that was unknown to their savage ancestors. The men are a little addicted to drunkenness, for they drink freely of the wine of the cocoa-nut. They love music and dancing much, but labour little. They are passionately fond of cock-fighting. On Sundays and holidays they gather together in crowds after the service, at the door of the church; where each Indian brings his cock to match him with that of his neighbour, and each bets upon his own.—The mission of Guam is now in the hands of the Augustine friars, who have supplanted the Jesuits. E. Long. 155. 10. N. Lat. 13. 25.

GUAMANGA, a considerable town of South America, and capital of a province of the same name in Peru, and in the audience of Lima, with a bishop's see. It is remarkable for its sweetmeats, manufactures, and mines of gold, silver, iron, and quicksilver. W. Long. 74. 56. S. Lat. 12. 50.

GUANUGO, a rich and handsome town of South America, and capital of a district of the same name in the audience of Lima. W. Long. 75. 56. S. Lat. 9. 55.

GUANZAVELCA, a district of South America, in Peru, and in the audience of Lima. It abounds in mines of quicksilver. W. Long. 74. 39. S. Lat. 12. 36.

GUARANTEE, or **WARRANTER**, in *Law*, a term relative to warrant or warranter, properly signifying him whom the warranter undertakes to indemnify or secure from damage.

GUARANTEE is more frequently used for a warranter,

Guam
||
Guarantee.

Guarantee
Guard.

or a person who undertakes and obliges himself to see a second person perform what he has stipulated to the third. See **WARRANTY**.

GUARANTY, in matters of polity, the engagement of mediatorial or neutral states, whereby they plight their faith that certain treaties shall be inviolably observed, or that they will make war against the aggressor.

GUARD, in a general sense, signifies the defence or preservation of any thing; the act of observing what passes, in order to prevent surprise; or the care, precaution, and attention we make use of to prevent any thing from happening contrary to our intentions or inclinations.

GUARD, in fencing, implies a proper posture to defend the body from the sword of the antagonist.

GUARD, in the military art, is a duty performed by a body of men, to secure an army or place from being surprised by an enemy. In garrison the guards are relieved every day: hence it comes that every soldier mounts guard once every three or four days in time of peace, and much oftener in time of war. See **HONOURS**.

Advanced GUARD, is a party of either horse or foot, that marches before a more considerable body, to give notice of any approaching danger. These guards are either made stronger or weaker, according to situation, the danger to be apprehended from the enemy, or the nature of the country.

Van GUARD. See *Advanced GUARD*.

Artillery GUARD, is a detachment from the army to secure the artillery when in the field. Their *corps de garde* is in the front of the artillery park, and their sentries dispersed round the same. This is generally a 48-hours guard; and, upon a march, this guard marches in the front and rear of the artillery, and must be sure to leave nothing behind: if a gun or waggon breaks down, the officer that commands the guard is to leave a sufficient number of men to assist the gunners and matrosses in getting it up again.

Artillery Quarter-GUARD, is frequently a non-commissioned officer's guard from the royal regiment of artillery, whose *corps de garde* is always in the front of their encampment.

Artillery Rear-GUARD, consists in a corporal and six men, posted in the rear of the park.

Corps de GARDE, are soldiers entrusted with the guard of a post, under the command of one or more officers. This word also signifies the place where the guard mounts.

Grand GUARD; three or four squadrons of horse, commanded by a field-officer, posted at about a mile or a mile and a half from the camp, on the right and left wings, towards the enemy, for the better security of the camp.

Forage GUARD, a detachment sent out to secure the foragers, and who are posted at all places, where either the enemy's party may come to disturb the foragers, or where they may be spread too near the enemy, so as to be in danger of being taken. This guard consists both of horse and foot, and must remain on their posts till the foragers are all come off the ground.

Main GUARD, is that from which all other guards are detached. Those who are for mounting guard assemble at their respective captain's quarters, and march from thence to the parade in good order; where, after the whole guard is drawn up, the small guards are detached to their respective posts: then the subalterns throw lots for their guards, who are all under the command of the captain of the main guard. This guard mounts in garrison at different hours, according as the governor pleases.

Piquet GUARD, a good number of horse and foot, always in readiness in case of an alarm: the horses are generally saddled all the time, and the riders booted.

The foot draw up at the head of the battalion, frequently at the beating of the tat-too; but afterwards return to their tents, where they hold themselves in readiness to march upon any sudden alarm. This guard is to make resistance in case of an attack, until the army can get ready.

Baggage GUARD, is always an officer's guard, who has the care of the baggage on a march. The waggons should be numbered by companies, and follow one another regularly: vigilance and attention in the passage of hollow ways, woods, and thickets, must be strictly observed by this guard.

Quarter GUARD, is a small guard commanded by a subaltern officer, posted in the front of each battalion, at 222 feet before the front of the regiment.

Rear GUARD, that party of the army which brings up the rear on a march, generally composed of all the old grand guards of the camp. The rear-guard of a party is frequently eight or ten horse, about 500 paces behind the party. Hence the advance-guard going out upon a party, form the rear-guard in their retreat.

Rear-GUARD, is also a corporal's guard placed in the rear of a regiment, to keep good order in that part of the camp.

Standard GUARD, a small guard under a corporal, out of each regiment of horse, who mount on foot in the front of each regiment, at the distance of 20 feet from the streets, opposite the main street.

Trench GUARD, only mounts in the time of a siege, and sometimes consists of three, four, or six battalions, according to the importance of the siege. This guard must oppose the besieged when they sally out, protect the workmen, &c.

Provost GUARD, is always an officer's guard that attends the provost in his rounds, either to prevent desertion, marauding, rioting, &c. See **PROVOST**.

Ordinary GUARDS, such as are fixed during the campaign, and relieved daily.

Extraordinary GUARDS, or detachments, which are only commanded on particular occasions, either for the further security of the camp, to cover the foragers, or for convoys, escorts, or expeditions.

GUARDS, also imply the troops kept to guard the king's person, and consist both of horse and foot.

Horse GUARDS, in England, are gentlemen chosen for their bravery, to be entrusted with the guard of the king's person; and were divided into four troops, called the *1st, 2d, 3d, and 4th troop of horse-guards*. The first troop was raised in the year 1660, and the command

Guard.

Guard.

command given to Lord Gerard; the second in 1661, and the command given to Sir Philip Howard; the third in 1693, and the command given to Earl Feversham; the fourth in 1702, and the command given to Earl Newburgh. Each troop had one colonel, two lieutenant-colonels, one cornet and major, one guidon and major, four exempts and captains, four brigadiers and lieutenants, one adjutant, four sub-brigadiers and cornets, and 60 private men. But the four troops are now turned into two regiments of life-guards.

Horse-Grenadier GUARDS, are divided into two troops called the *1st and 2d troops of horse-grenadier guards*. The first troop was raised in 1693, and the command given to Lieutenant-general Cholmondeley; the second in 1702, and the command given to Lord Forbes. Each troop has one colonel, lieutenant-colonel, one guidon or major, three exempts and captains, three lieutenants, one adjutant, three cornets, and 60 private men.

Yeomen of the GUARD, first raised by Henry VII. in the year 1485. They are a kind of pompous foot-guards to the king's person; and are generally called by a nickname the *Beef-Eaters*. They were anciently 250 men of the first rank under gentry; and of larger stature than ordinary, each being required to be six feet high. At present there are but 100 in constant duty, and 70 more not on duty; and when any one of the 100 dies, his place is supplied out of the 70. They go dressed after the manner of King Henry VIII.'s time. Their first commander or captain was the earl of Oxford, and their pay is 2s. 6d. per day.

Foot GUARDS, are regiments of foot appointed for the guard of his majesty and his palace. There are three regiments of them, called the *1st, 2d, and 3d, regiments of foot-guards*. They were raised in the year 1660; and the command of the first given to Colonel Russel, that of the second to General Monk, and the third to the earl of Linlithgow. The first regiment is at present commanded by one colonel, one lieutenant-colonel, three majors, 23 captains, one captain-lieutenant, 31 lieutenants, and 24 ensigns; and contains three battalions. The second regiment has one colonel, one lieutenant-colonel, two majors, 14 captains, one captain-lieutenant, 18 lieutenants, 16 ensigns, and contains only two battalions. The third regiment is the same as the second.

The *French GUARDS* are divided into those within, and those without the palace.—The first are the *gardes du corps*, or body guards; which consist of four companies, the first of which companies was anciently Scots. See *Scots GUARDS, infra*.

The guards without are the *Gens d'Armes*, light horse, musqueteers, and two other regiments, the one of which is French and the other Swiss.

New arrangements, however, have taken place in this department as well as others since the late revolution.

Scots GUARDS, a celebrated band, which formed the first company of the ancient *gardes du corps* of France.

It happened from the ancient intercourse between France and Scotland, that the natives of the latter kingdom had often distinguished themselves in the service of the former. On this foundation the company of Scots guards, and the company of Scots gendarmes, were in-

stituted.—Both of them owed their institution to Charles VII. of France, by whom the first standing army in Europe was formed, *anno* 1454; and their fates cannot but be interesting to Scotsmen. See *GEN-DARMES*.

Valour, honour, and fidelity, must have been very conspicuous features of the national character of the Scots, when so great and civilized a people as the French could be induced to choose a body of them, foreigners as they were, for guarding the persons of their sovereigns.—Of the particular occasion and reasons of this predilection we have a recital by Louis XII. a succeeding monarch. After setting forth the services which the Scots had performed for Charles VII. in expelling the English out of France, and reducing the kingdom to his obedience, he adds—“Since which occasion, and for the great loyalty and virtue which he found in them, he selected 200 of them for the guard of his person, of whom he made an hundred men at arms, and an hundred life-guards: And the hundred men at arms are the hundred lances of our ancient ordinances; and the life-guard men are those of our guard who still are near and about our person.”—As to their fidelity in this honourable station, the historian, speaking of Scotland, says, “The French have so ancient a friendship and alliance with the Scots, that of 400 men appointed for the king's life-guard, there are an hundred of the said nation who are the nearest to his person, and in the night keep the keys of the apartment where he sleeps. There are, moreover, an hundred complete lances and two hundred yeomen of the said nation, besides several that are dispersed through the republic: And for so long a time as they have served in France, never hath there been one of them found that hath committed or done any fault against the kings or their estate; and they make use of them as of their own subjects.”

The ancient rights and privileges of the Scottish life-guards were very honourable; especially of the twenty-four first. The author of the *Ancient Alliance* says, “On high holidays, at the ceremony of the royal touch, the erection of knights of the king's order, the reception of extraordinary ambassadors, and the public entries of cities, there must be six of their number next to the king's person, three on each side; and the body of the king must be carried by these only, where-soever ceremony requires. They have the keeping of the keys of the king's lodging at night, the keeping of the choir of the chapel, the keeping the boats where the king passes the rivers; and they have the honour of bearing the white silk fringe in their arms, which in France is the *coronne couleur*. The keys of all the cities where the king makes his entry are given to their captain in waiting or out of waiting.—He has the privilege, in waiting or out of waiting, at ceremonies, such as coronations, marriages, and funerals of the kings, and at the baptism and marriage of their children, to take duty upon him. The coronation robe belongs to him; and this company, by the death or change of a captain, never changes its rank, as do the three others.”

This company's first commander, who is recorded as a person of great valour and military accomplishments, was Robert Patillock, a native of Dundee;

Guard.

Hist. of Louis XII. by Claud Seyail, master of requests to that prince.

Guard,
Guardian.

and the band, ever ardent to distinguish itself, continued in great reputation till the year 1578. From that period, the Scots guards were less attended to, and their privileges came to be invaded. In the year 1612, they remonstrated to Louis XIII. on the subject of the injustice they had suffered, and set before him the services they had rendered to the crown of France. Attempts were made to re-establish them on their ancient foundation; but no negotiation for this purpose was effectual. The troops of France grew jealous of the honours paid them: the death of Francis II. and the return of Mary to Scotland, at a time when they had much to hope, were unfortunate circumstances to them: the change of religion in Scotland was an additional blow; and the accession of James VI. to the throne of England disunited altogether the interests of France and Scotland. The Scots guards of France had therefore, latterly, no connection with Scotland but the name.

GUARD-BOAT, a boat appointed to row the rounds amongst the ships of war which are laid up in any harbour, &c. to observe that their officers keep a good looking-out, calling to the guard-boat as she passes, and not suffering her crew to come on board, without having previously communicated the watch-word of the night.

GUARD-SHIP, a vessel of war appointed to superintend the marine affairs in a harbour or river, and to see that the ships which are not commissioned have their proper watch-word kept duly, by sending her guard-boats around them every night. She is also to receive seamen who are impressed in the time of war.

GUARDIAN, in *Law*, a person who has the charge of any thing; but more commonly it signifies one who has the custody and education of such persons as have not sufficient discretion to take care of themselves and their own affairs, as children and idiots.

Their business is to take the profits of the minor's lands to his use, and to account for the same: they ought to sell all moveables within a reasonable time, and to convert them into land or money, except the minor is near of age, and may want such things himself; and they are to pay interest for the money in their hands that might have been so placed out; in which case it will be presumed that the guardians made use of it themselves. They are to sustain the lands of the heir, without making destruction of any thing thereon, and to keep it safely for him: if they commit waste on the lands, it is a forfeiture of the guardianship, 3 Edw. I. And where persons, as guardians, hold over any land, without the consent of the person who is next entitled, they shall be adjudged trespassers, and shall be accountable; 6 Ann. cap. xviii.

GUARDIAN, or *Warden*, of the *Cinque-ports*, is an officer who has the jurisdiction of the cinque-ports, with all the power that the admiral of England has in other places.

Camden relates, that the Romans, after they had settled themselves and their empire in our island, appointed a magistrate, or governor, over the east parts where the Cinque-ports lie, with the title of *comes littoris Saxonici per Britanniam*; having another, who bore the like title, on the opposite side of the sea. Their business was to strengthen the sea coast with munition,

against the outrages and robberies of the barbarians; and that antiquary takes our warden of the Cinque-ports to have been erected in imitation thereof. The wardenship is a place of value, supposed worth 7000l. per annum.

GUARDIAN of the Spiritualities, the person to whom the spiritual jurisdiction of any diocese is committed, during the time the see is vacant. A guardian of the spiritualities may likewise be either such in law, as the archbishop is of any diocese within his province; or by delegation, as he whom the archbishop or vicar general for the time appoints. Any such guardian has power to hold courts, grant licenses, dispensations, probates of wills, &c.

GUAREA, a genus of plants belonging to the octandria class. See *BOTANY Index*.

GUARINI, *BATTISTA*, a celebrated Italian poet, born at Ferrara in 1538. He was great grandson to Guarino of Verona, and was secretary to Alphonso duke of Ferrara, who intrusted him with several important commissions. After the death of that prince, he was successively secretary to Vincensio de Gonzaga, to Ferdinand de Medicis grand duke of Tuscany, and to Francis Maria de Feltri duke of Urbino. But the only advantages he reaped under these various masters were great encomiums on his wit and compositions. He was well acquainted with polite literature; and acquired immortal reputation by his Italian poems; especially by his *Pastor Fido*, the most known and admired of all his works, and of which there have been innumerable editions and translations. He died in 1612.

GUARDIA, or *GUARDA*, a town of Portugal, in the province of Beira, with a bishop's see. It contains about 2300 inhabitants, is fortified both by art and nature, and has a stately cathedral. W. Long. 6. 55. N. Lat. 40. 20.

GUARDIA-Alferex, a town of Italy, in the kingdom of Naples, and in the Contado di Molise, with a bishop's see. E. Long. 14. 56. N. Lat. 41. 39.

GUARGALA, or *GUERGUELA*, a town of Africa, and capital of a small kingdom of the same name, in Biledulgerid, to the south of Mount Atlas. E. Long. 9. 55. N. Lat. 28. 0.

GUARIBA, the name of a species of monkey. See *SIMIA*, *MAMMALIA Index*.

GUASTALLA, a strong town of Italy, with the title of a duchy, remarkable for a battle between the French and Imperialists in 1734. It was ceded to the duke of Parma in 1748, and now belongs to the late empress of France, Maria Louisa. It is seated near the river Po, in E. Long. 10. 38. N. Lat. 44. 55.

GUATIMALA, the audience and province of, in New Spain, is above 750 miles in length, and 450 in breadth. It is bounded on the west by Soconusco, on the north by Verapax and Honduras, on the east by Nicaragua, and on the south by the South sea. It abounds in chocolate, which they make use of instead of money. It has 12 provinces under it: and the native Americans, under the dominions of Spain, profess Christianity, mixed indeed with many of their own superstitious. There is a great chain of high mountains, which run across it from east to west, and it is subject to earthquakes and storms. It is, however, very fertile; and produces, besides chocolate, great quantities

Guatemala
Gudgeon.

ties of cochineal and cotton, indigo, woad, &c. See GUATIMALA, SUPPLEMENT.

GUATIMALA, *St Jago de*, is the capital of the above audience, with a bishop's see, and an university. It carries on a great trade, especially in chocolate. W. Long. 92. 40. N. Lat. 14. 28.

St Jago de Guatemala was almost ruined in 1541, by a storm and an eruption from the volcanic mountain Guatemala. It was afterwards rebuilt at a good distance from this mountain. But in 1773, it was again destroyed by a terrible earthquake. The town then contained 40,000 inhabitants; but no traces of it now remain; 8000 persons perished by this earthquake, and the loss has been estimated at 15 millions sterling.

GUAVA. See PSIDIUM, BOTANY *Index*.

GUAXACA, a province in the audience of Mexico, in New Spain, which is very fertile in wheat, Indian corn, cochineal, and cassia. It is bounded by the gulf of Mexico on the north, and by the South sea on the south. It contains mines of gold and silver. Guaxaca is the capital town.

GUAXACA, the capital town of the above province, with a bishop's see. It is without walls, and does not contain above 2000 inhabitants; but it is rich, and they make very fine sweet-meats and chocolates. It has several rich convents, both for men and women. W. Long. 97. 40. N. Lat. 17. 10.

GUAYRA, a district of the province of La Plata, in South America, having Brasil on the east, and Paraguay on the west.

GUBEN, a handsome town of Germany, in Lower Lusatia, seated on the river Neisse, and now belonging to the king of Prussia. E. Long. 14. 59. N. Lat. 51. 55.

GUBER, a kingdom of Africa, in Negroland. It is surrounded with high mountains; and the villages, which are many, are inhabited by people who are employed in taking care of their cattle and sheep. There are also abundance of artificers, and linen-weavers, who send their commodities to Tombuto. The whole country is overflowed every year by the inundations of the Niger, and at that time the inhabitants sow their rice. There is one town which contains almost 6000 families, among whom are many merchants.

GUBIO, a town of Italy, in the territory of the church, and in the duchy of Urbino, with a bishop's see. E. Long. 12. 38. N. Lat. 43. 18.

GUDGEON, a species of cyprinus. See CYPRINUS, ICHTHYOLOGY *Index*.

This fish, though small, is of so pleasant a taste, that it is very little inferior to smelt. They spawn twice in the summer season; and their feeding is much like the barbels in streams and on gravel, alighting all manner of flies: but they are easily taken with a small red worm, fishing near the ground; and being a leather-mouthed fish, will not easily get off the hook when struck.—The gudgeon may be fished for with float, the hook being on the ground; or by hand, with a running line on the ground, without cork or float. But although the small red worm above mentioned is the best bait for this fish, yet wasps, gentles, and cad-baits will do very well. You may also fish for gudgeons with two or three hooks at once, and find very pleasant sport, where they rise any thing large. When you angle for them, stir up the sand or gravel with a

long pole; this will make them gather to that place, bite faster, and with more eagerness.

Sea GUDGEON, *Rock fish*, or *Black Goby*. See COBIUS, ICHTHYOLOGY *Index*.

GUEBRES, or GABRES. See GABRES.

GUELPHS, or GUELFs, a celebrated faction in Italy, antagonists of the Gibelins. See GIBELINS.

The Guelphs and Gibelins filled Italy with blood and carnage for many years. The Guelphs stood for the Pope, against the emperor. Their rise is referred by some to the time of Conrad III. in the twelfth century; by others to that of Frederick I.; and by others to that of his successor Frederick II. in the thirteenth century.

The name of *Guelph* is commonly said to have been formed from *Welfe*, or *Welfo*, on the following occasion: the emperor Conrad III. having taken the duchy of Bavaria from Welfe VI. brother of Henry duke of Bavaria, Welfe, assisted by the forces of Roger king of Sicily, made war on Conrad, and thus gave birth to the faction of the Guelphs.

Others derive the name *Guelphs* from the German *Wolff*, on account of the grievous evils committed by that cruel faction: others deduce the denomination from that of a German called *Guelse*, who lived at Pistoye; adding, that his brother, named *Gibel*, gave his name to the Gibelins. See the article GIBELINS.

GUELDERLAND, one of the united provinces, bounded on the west by Utrecht and Holland, on the east by the Prussian Rhenish territories, on the north by the Zuyder sea and Overysseel, and on the south it is separated from Brabant by the Maese. Its greatest extent from north to south is about 47 miles, and from west to east near as much. It comprises about 2020 square miles, and contains 243,000 inhabitants. The air here is much healthier and clearer than in the maritime provinces, the land lying higher. It is watered by the Rhine, and its three branches, the Wahal, the Yssel, and the Leck, besides lesser streams. The soil is in many parts heavy, and in others sandy, and upon the whole not very fertile. The principal productions are corn, potatoes, fruit, tobacco, and hops. There are some manufactures in the province of linen, paper, and leather. A considerable part of the trade consists of the transit of goods from the coast to the interior of Germany. The greater part of the inhabitants are Protestants. In 1079, it was raised to a county by the emperor Henry IV. and in 1339 to a duchy by the emperor Louis of Bavaria. It had dukes of its own till 1528, when it was yielded up to the emperor Charles V. In 1576, it acceded to the union of Utrecht. The places of most note are Nimeguen, Zutphen, Arnheim, Harderwyst, Loo, &c.

GUELDRES, a strong town of the Netherlands, in the duchy of the same name. It was ceded to the king of Prussia, by the peace of Utrecht. It surrendered to the French in 1794, but was restored to Prussia in 1814. E. Long. 6. 10. N. Lat. 51. 30.

GUERCINO. See BARBIERI.

GUERICKE, OTTO or OTHO, a German philosopher of considerable eminence, was born in 1602, and died at Hamburg in 1686. In conjunction with Torricelli, Paschal, and Boyle, he contributed much to the farther explanation of the properties of air. He was counsellor to the elector of Brandenburg, and bur-

Gudgeon
Guericke.

Guericke
Guiana.

gomaster of Magdeburg, but his greatest celebrity was derived from his philosophical discoveries, in a particular manner the invention of the air-pump. Mr Boyle indeed made approaches towards the discovery of it much about the same time, but with that candour which is ever the characteristic of great and enlightened minds, he confessed that the merit of it belonged exclusively to Guericke, the account of whose experiments first enabled him to bring his design to any thing like maturity. Our author has also the merit of inventing the two brass hemispheres, by which the pressure of the air is illustrated, and an instrument for determining the changes in the state of the atmosphere, which fell into disuse on the invention of the barometer. By consulting his tube he predicted approaching storms, on which account he was deemed a sorcerer by the ignorant multitude. It is worthy of observation, that when his brass hemispheres were applied to each other, and the air exhausted, it resisted the efforts of sixteen horses to draw them asunder. He composed several treatises in natural philosophy, the principal of which is entitled *Experimenta Magdeburgica*, 1672, folio, which contains his experiments on a vacuum.

GUERNSEY, an island in the English channel on the coast of Normandy, subject to Britain; but (as well as the adjacent islands) governed by its own laws. See JERSEY. It extends from east to west in the form of a harp, and is thirteen miles and a half from the south-west to north-east, and twelve and a half, where broadest, from east to west. The air is very healthy, and the soil naturally more rich and fertile than that of Jersey; but the inhabitants neglect the cultivation of the land for the sake of commerce: they are, however, sufficiently supplied with corn and cattle, both for their own use and that of their ships. The island is well fortified by nature with a ridge of rocks, one of which, it was said, afforded emery; but from late inquiries this appears to be a mistake, no such substance being found in the island. Here is a better harbour than any in Jersey, which occasions its being more resorted to by merchants; and on the south side the shore bends in the form of a crescent, enclosing a bay capable of receiving very large ships. The island is full of gardens and orchards. The population is 21,293, including 2000 sailors or persons not permanently settled in the country.

GUETTARDA, a genus of plants belonging to the monœcia class, and in the natural method ranking under the 38th order, *Tricoccæ*. See BOTANY *Index*.

GUIANA, a large country of South America, is bounded on the east and north by the Atlantic ocean, and the river Oroonoko; on the south, by the river of the Amazons; and on the west, by the provinces of Grenada and New Andalusia in Terra Firma, from which it is separated both on the west and north by the river Oroonoko. It extends above 1200 miles from the north-east to the south-west, that is, from the mouth of the river Oroonoko to the mouth of the river of the Amazons, and near 600 in the contrary direction.

Most geographers divide it into two parts, calling the country along the coast *Caribbeana Proper*, and the interior country *Guiana Proper*: The last is also styled *El Dorado* by the Spaniards, on account of the immense quantity of gold it is supposed to contain.

The Portuguese, French, and Dutch, have all settlements along the coast. What lies south of Cape North belongs to the first of these nations; the coast between Cape North and Cape Orange is possessed by the natives; French Guiana, Old Cayenne, or Equinoctial France, extends from Cape Orange, about 240 miles along the coast, to the river Marani; where the Dutch territory begins, and extends to the mouth of the Oroonoko.

Along the coast, the land is low, marshy, and subject to inundations in the rainy season, from a multitude of rivers which descend from the inland mountains. Hence it is, that the atmosphere is suffocating, hot, moist, and unhealthy, especially where the woods have not been cleared away. Indeed, the Europeans are forced to live in the most disagreeable situations, and fix their colonies at the mouths of the rivers, amidst stinking marshes, and the putrid ooze of salt morasses, for the conveniency of exportation and importation.

"Dutch Guiana (according to the account of a physician who resided several years at Surinam) was first discovered by Columbus in 1498. It lies between the 7° of north and the 5° of south latitude, and between the 53° and 60° of longitude, west from London. It is bounded on the north and east, by the Atlantic; on the west, by the rivers Oroonoko and Negroe; and on the south, by the river of the Amazons.

"It was formerly divided among the Spaniards, Dutch, French, and Portuguese; but, except its sea coast, and lands adjacent to its rivers, it has hitherto remained unknown to all but its original natives; and even of these, it is only what were the Dutch territories that foreigners have any knowledge of; for those of the Spaniards, French, and Portuguese, are inaccessible to them.

"This country, on account of the diversity and fertility of its soil, and of its vicinity to the equator, which passes through it, affords almost all the productions of the different American countries between the tropics, besides a variety peculiar to itself."

Dutch Guiana was formerly the property of the English, who made settlements at Surinam, where a kind of corrupt English is still spoken by the negroes. The Dutch took it in the reign of Charles the Second; and it was ceded to them by a treaty in 1674, in exchange for what they had possessed in the province now called *New York*.

The land for 50 miles up the country from the sea-coast is flat; and, during the rainy seasons, covered two feet high with water. This renders it inconceivably fertile, the earth, for 12 inches deep, being a stratum of perfect manure. An attempt was once made to carry some of it to Barbadoes; but the wood-ants so much injured the vessel, that it was never repeated. The excessive richness of the soil is a disadvantage, for the canes are too luxuriant to make good sugar; and therefore, during the first and second crops, are converted into rum.

There are some trees on this part; but they are small and low, consisting chiefly of a small species of palm, intermixed with a leaf near 30 feet long and three feet wide, which grows in clusters, called a *Troælie*, and at the edges of running-water, with mangroves.

Guiana.

Guiana.

Farther inward the country rises; and the soil, though still fertile, is less durable. It is covered with forests of valuable timber, that are always green; and there are some sandy hills, though no mountains; in the French territories, however, there are mountains, according to the report of the Indians, for they have never been visited by any other people.

In this country the heat is seldom disagreeable; the trade-winds by day, the land breezes in the evening, and the invariable length of the nights, with gentle dews, refresh the air, and render it temperate and salubrious. There are two wet seasons and two dry, of three months each, in every year: and, during more than a month in each wet season, the rain is incessant. The dry seasons commence six weeks before the equinoxes, and continue six weeks after. The wet seasons are more wholesome than the dry, because the rains keep the waters that cover the low lands, next the sea, fresh and in motion; but during the dry season it stagnates, and, as it wastes, becomes putrid, sending up very unwholesome exhalations. Blossoms, green and ripe fruit, are to be found upon the same tree in every part of the year. There are some fine white and red agates in Guiana, which remain untouched; and mines of gold and silver, which the Dutch will not suffer to be wrought.

The inhabitants of Guiana are either natives, who are of a reddish brown; or negroes and Europeans; or a mixed progeny of these in various combinations. The natives are divided into different tribes, more or less enlightened and polished, as they are more or less remote from the settlements of the Europeans. They allow polygamy, and have no division of lands. The men go to war, hunt, and fish; and the women look after domestic concerns, spin, weave in their fashion, and manage the planting of cassava and manioc, the only things which in this country are cultivated by the natives. Their arms are bows and arrows; sharp poisoned arrows, blown through a reed, which they use in hunting; and clubs made of a heavy wood called *Iron-wood*. They eat the dead bodies of those that are slain in war; and sell for slaves those they take prisoners; their wars being chiefly undertaken to furnish the European plantations. All the different tribes go naked. On particular occasions they wear caps of feathers; but, as cold is wholly unknown, they cover no part but that which distinguishes the sex. They are cheerful, humane, and friendly; but timid, except when heated by liquor, and drunkenness is a very common vice among men.

Their houses consist of four stakes set up in a quadrangular form, with cross poles, bound together by slit nibbees, and covered with the large leaves called *troæthes*. Their life is ambulatory; and their house, which is put up and taken down in a few hours, is all they have to carry with them. When they remove from place to place, which, as they inhabit the banks of rivers, they do by water in small canoes, a few vessels of clay made by the women, a flat stone on which they bake their bread, and a rough stone on which they grate the roots of the cassava, a hammock and a hatchet, are all their furniture and utensils; most of them, however, have a bit of looking-glass framed in paper, and a comb.

VOL. X. Part I.

†

Their poisoned arrows are made of splinters of a hard heavy wood, called *cacario*; they are about 12 inches long, and somewhat thicker than a coarse knitting needle: one end is formed into a sharp point; round the other is wound some cotton to make it fit the bore of the reed through which it is to be blown. They will blow these arrows 40 yards with absolute certainty of hitting the mark, and with force enough to draw blood, which is certain and immediate death. Against this poison no antidote is known. The British, Dutch, French, Spaniards, and Portuguese, have each settlements in this country. See an account of each, and of the climate, soil, and population of the country, in the article GUIANA, SUPPLEMENT.

GUIAQUIL, also denominated by some *GUAIQUIL*, a city, bay, harbour, and river, in Peru, South America. The city is the second of Spanish origin, being as old as the year 1534. It lies on the west side of the river of the same name, in 2° 12' S. Lat. and 79° 6' W. Long. It is divided into the old and new towns, between which there is a communication by means of a wooden bridge. It is two miles in extent, and defended by two forts. The churches, convents, and houses, are of wood, and it contains about 20,000 inhabitants. This place is noted for a shell-fish no larger than a nut, which produces a beautiful purple dye. The commerce here is very considerable, the productions of the country alone forming the greatest part of it, which consist of timber, salt, horned cattle, mules and colts, pepper, drugs, and fine wool.

GUIAQUIL, a jurisdiction of South America, in the audience of Quito, near the Pacific ocean, a country subject to heavy rains and frequent storms, and abounding with troublesome insects.

GUIARA, a sea-port town of South America, and on the Caracca coast. It has a considerable trade, with a population amounting to 6000. W. Long. 67. O. N. Lat. 10. 35.

GUICCIARDINI, FRANCISCO, a celebrated historian, born at Florence in 1482. He professed the civil law with reputation, and was employed in several embassies. Leo X. gave him the government of Modena and Reggio, and Clement VII. that of Romagna and Bologna. Guicciardini was also lieutenant-general of the pope's army, and distinguished himself by his bravery on several occasions; but Paul III. having taken from him the government of Bologna, he retired to Florence, where he was made counsellor of state, and was of great service to the house of Medicis. He at length retired into the country to write his history of Italy, which he composed in Italian, and which comprehends what passed from the year 1494 to 1532. This history is greatly esteemed; and was continued by John Baptist Adriani, his friend. He died in 1540.

GUICCIARDINI, Lewis, his nephew, composed a history of the Low Countries, and memoirs of the affairs of Europe, from 1530 to 1560. He wrote with great spirit against the persecution of the duke d'Alva, for which he imprisoned him. He died in 1583.

GUIDES, in military language, are usually the country people in the neighbourhood of an encampment; who give the army intelligence concerning the country, the roads by which they are to march, and the probable route of the enemy.

R

GUIDI,

Guiana
||
Guides.

Guidi
||
Gauld.

GUIDI, ALEXANDER, an eminent Italian poet, born at Pavia in 1650. Having a desire to see Rome, he there attracted the notice of Queen Christina of Sweden, who retained him at her court; he also obtained a considerable benefice from Pope Innocent XI. and a pension from the duke of Parma. For a good office he did the state of Milan with Prince Eugene, he was enrolled among the nobles and decurions of that town; and died in 1712. Nature had been kinder to his intellects than to his exterior form; his body was small and crooked, his head was large, and he was blind of his right eye. A collection of his works was published at Verona in 1726.

GUIDO ARETIN. See **ARETIN.**

GUIDO RENT, an illustrious Italian painter, born at Bologna in 1595. In his early age he was the disciple of Denis Calvert, a Flemish master of good reputation; but afterwards entered himself in the school of the Caracci. He first imitated Ludovico Caracci; but fixed at last in a peculiar style of his own, that secured him the applause of his own time and the admiration of posterity. He was much honoured, and lived in splendor: but an unhappy attachment to gaming ruined his circumstances; the reflection of which brought on a languishing disorder, that put an end to his life in 1642. There are several designs of this great master in print, etched by himself.

GUIDON, a sort of flag or standard borne by the king's life-guard; being broad at one extreme, and almost pointed at the other, and slit or divided into two. The guidon is the ensign or flag of a troop of horse-guards. See **GUARD.**

GUIDON, also denotes the officer who bears the guidon. The guidon is that in the horse-guards which the ensign is in the foot. The guidon of a troop of horse takes place next below the cornet.

GUIDONS, Guidones, or Schola Guidonum, was a company of priests established by Charlemagne, at Rome, to conduct and guide pilgrims to Jerusalem, to visit the holy places: they were also to assist them in case they fell sick, and to perform the last offices to them in case they died.

GUIENNE, a large province of France, now forming the department of Gironde and that of Lot and Garonne, bounded on the north by Saintogne, Angoumois, and Limosin; on the east by Limosin, Auvergne, and Languedoc; on the south by the Pyrenees, Lower Navarre, and Bearn; and on the west by the ocean. It is about 225 miles in length, and 200 in breadth. It is divided into the Upper and Lower. The Upper comprehends Querci, Rouergue, Armagnac, the territory of Comminges, and the county of Bigorre. The Lower contains Bourdelois, Perigord, Agenois, Condomois, Bazadois, the Lander, Proper Gascony, and the district of Labour. The principal rivers are, the Garonne, the Adour, the Tarn, the Aveziron, and the Lot. Bourdeaux is the capital town.

GUILANDINA, the **NICKAR TREE**, a genus of plants belonging to the decandria class, and in the natural method ranking under the 33d order, *Lomentaceæ*. See **BOTANY Index.**

GUILD, (from the Saxon *guldene*, to "pay"), signifies a fraternity or company, because every one was *gildare*, i. e. to pay something towards the charge and support of the company. As to the original of

these guilds or companies: It was a law among the Saxons, that every freeman of fourteen years of age should find sureties to keep the peace, or be committed: upon which certain neighbours, consisting of ten families, enter into an association, and become bound for each other, either to produce him who committed an offence, or to make satisfaction to the injured party: that they might the better do this, they raised a sum of money among themselves, which they put into a common stock; and when one of their pledges had committed an offence, and was fled, then the other nine made satisfaction out of this stock, by payment of money, according to the offence. Because this association consisted of ten families, it was called a *decennary*: and from hence came out later kinds of fraternities. But as to the precise time when these guilds had their origin in England, there is nothing of certainty to be found; since they were in use long before any formal licence was granted to them for such meetings. It seems to have been about the close of the eleventh century, says Anderson, in his History of Commerce, vol. i. p. 70. that merchant-guilds, or fraternities, which were afterwards styled corporations, came first into general use in many parts of Europe. Mr Madox, in his *Firma Burgi*, chap. i. § 9. thinks, they were hardly known to our Saxon progenitors, and that they might be probably brought into England by the Normans; although they do not seem to have been very numerous in those days. The French and Normans might probably borrow them from the free cities of Italy, where trade and manufactures were much earlier propagated, and where possibly such communities were first in use. These guilds are now companies joined together, with laws and orders made by themselves, by the licence of the prince.

GUILD, in the royal boroughs of Scotland, is still used for a company of merchants, who are freemen of the borough. See **BOROUGH.**

Every royal borough has a dean of *guild*, who is the next magistrate below the bailie. He judges of controversies among men concerning trade; disputes between inhabitants touching buildings, lights, water-courses, and other nuisances; calls courts, at which his brethren of the *guild* are bound to attend; manages the common stock of the *guild*; and amerces and collects fines.

GUILD, Gild or Geld, is also used among our ancient writers, for a compensation or mulct, for a fault committed.

GUILD-Hall, or Gild-Hall, the great court of judicature for the city of London. In it are kept the mayor's court, the sheriff's court, the court of hustings, court of conscience, court of common council, chamberlain's court, &c. Here also the judges sit upon *nisi prius*, &c.

GUILDFORD, or GULDFORD, a borough-town of Surrey, situated on the river Wey, 31 miles south-west of London. Near it are the ruinous walls of an old castle, this having been in the Saxon times a royal villa, where many of our kings used to pass the festivals. Here is a corporation consisting of a mayor, recorder, aldermen, &c. which sent members to parliament ever since parliament had a being. The great road from London to Chichester and Portsmouth lies through this town, which has always been famous for good

Guild,
Guildford.

Guildford good inns, the cleanest of linen, and other excellent accommodations; and the assizes are often held here. Its manufactory formerly was cloth, of which there are still some small remains. Here is a school founded by King Edward VI. also an alms-house endowed with lands worth 300l. a-year, of which 100l. to be employed in setting the poor at work, and the other 200l. for the maintenance of a master, 12 brethren, and 8 sisters, who are to have 2s. 6d. a week. There are, besides, two charity schools for 30 boys and 20 girls. There were three churches in this town, but one of them fell down in April 1740. There is a fine circular course for horse-matches, which begin when the Newmarket races are ended. King William III. founded a plate of 100 guineas to be run for here every May, and used to honour the race with his presence, as did once King George I. The river Wey is made navigable to the town, and by it a great quantity of timber is carried to London, not only from this neighbourhood, but from Sussex and Hampshire woods, above 30 miles off, from whence it is brought hither in the summer by land carriage. This navigation is also of great support to Farnham market, corn bought there being brought to the mills on this river within seven miles distance, and, after being ground and dressed, is sent down in barges to London. The road from hence to Farnham is very remarkable, for it runs along upon the ridge of a high chalky hill, called *St Catharine's*, no wider than the road itself, from whence there is an extensive prospect, viz. to the north and north-west, over Bagshot heath, and the other way into Sussex. Population 2974 in 1811. The town sends two members to parliament; and gives title of earl to the North family.

GUILLEMOT. See COLYMBUS, ORNITHOLOGY *Indes.*

GULLIM, JOHN, of Welsh extraction, was born in Herefordshire about the year 1565. Having completed his education at Brazen-nose college, Oxford, he became a member of the college of arms in London; and he was made rouge croix pursuivant, in which post he died in 1621. He published, in 1610, a celebrated work, entitled the Display of Heraldry, folio, which has gone through many editions. To the fifth, which came out in 1679, was added A Treatise of Honour Civil and Military, by Captain John Loggan.

GUILLOTINE, the name of an instrument introduced by the authors of the French revolution, for beheading those who were condemned to death. The decree for using it passed on the 20th of March 1792, by order of the national assembly. It was not a new invention, properly speaking, but the revival of an instrument known before. It seems to have been first used under the name of *maiden*, in the barony of Halifax in Yorkshire, and it was likewise set up in Scotland, but we have no good authority for asserting that it was ever used, although some are of opinion that Regent Morton, who brought a model of it from England, suffered by it himself. See MAIDEN.

Guillotine, the supposed inventor, a physician of Lyons, and a member of the national assembly, thought it an honour conferred upon his name, by having it united with this instrument of death. His invention was expensive, and it received the most unqualified applause, both from the members and from the galleries. The propriety of using it was referred to a committee,

with instructions to take the opinion of the most able surgeons respecting it. M. Louis, an eminent surgeon of Paris, declared it well fitted for the task, and commended the judgment of M. Guillotine in the contrivance. His discovery upon this occasion was rewarded by the legislature with a donation of 2000 livres; and it was ordered to be printed in the Paris Journals.

As far as this instrument diminishes the duration of the dreadful conflict with death, it may be deemed merciful, and is, in this respect, preferable to the hanging of malefactors by the neck; but the agitation of the mind is probably augmented by the long series of preparatory operations. The hands of the criminal are tied behind his back; he is stretched on his face on a strong plank. He is then fastened to the plank, his neck is adjusted to the block, and a basket placed before him to receive his head, which in the speediest manner must take up some time, although we recollect to have read of 21 (viz. Brissot and his party) who were all decapitated in the course of 36 minutes.

The construction of the guillotine has been variously modified, and was at length made so portable as to constitute part of the travelling equipage of a commissioner from the national assembly; and a representation of it was put upon the coins, as an ornament. On a piece of ten sous value, which was struck at Mentz in the year 1793, there was for the device, the fasces and axe of ancient Rome, crowned with a red cap, and surrounded by a laurel wreath, having for an inscription, *Republique Françoise, 1793, (an 2).*

GUINEA, a large tract of country lying on the west side of the continent of Africa, extends along the coast three or four thousand miles, beginning at the river Senegal, situated about the 17th degree of north latitude (being the nearest part of Guinea as well to Europe as to North America). From that river to the river Gambia, and in the southerly course to Cape Sierra Leona, is comprehended a coast of about 700 miles; being the same tract for which Queen Elizabeth granted charters to the first traders to that coast. From Sierra Leona, the land of Guinea takes a turn to the eastward, extending that course about 1500 miles, including those several divisions known by the names of the *Grain Coast*, the *Ivory Coast*, the *Gold Coast*, and the *Slave Coast*, with the large kingdom of *Benin*. From thence the land runs southward along the coast about 1200 miles, which contains the kingdoms of *Congo* and *Angola*; where the trade for slaves ends. From which to the southermost cape of Africa, called the *Cape of Good Hope*, the country is settled by Caffres and Hottentots, who have never been concerned in the making or selling slaves.

1. Of the parts which are above mentioned, the first is that situated on the great river Senegal, which is said to be navigable more than 1000 miles, and is by travellers described to be very agreeable and fruitful. Mr Brue, principal factor for the French African company, who lived 16 years in that country, after describing its fruitfulness and plenty near the sea, adds, "The farther you go from the sea, the country on the river seems the more fruitful and well improved, abounding with Indian corn, pulse, fruit, &c. vol. ii. Here are vast meadows, which feed large herds of great and small cattle, and poultry numerous: the villages that lie thick on the river, show the country

Guinea.

is well peopled." The same author, in the account of a voyage he made up the river Gambia, the mouth of which lies about 300 miles south of the Senegal, and is navigable about 600 miles up the country, says, "that he was surprised to see the land so well cultivated; scarce a spot lay unimproved; the low lands divided by small canals were all sowed with rice, &c. the higher ground planted with millet, Indian corn, and pease of different sorts; their beef excellent; poultry plenty and very cheap, as well as all other necessaries of life." Mr Moore, who was sent from England about the year 1735, in the service of the African company, and resided at James Fort on the river Gambia, or in other factories on that river, about five years, confirms the above account of the fruitfulness of the country. Captain Smith, who was sent in the year 1726 by the African company to survey their settlements throughout the whole coast of Guinea, says *, "the country about the Gambia is pleasant and fruitful; provisions of all kinds being plenty and exceeding cheap." The country on and between the two above-mentioned rivers is large and extensive, inhabited principally by those three Negro nations known by the name of *Jalofs*, *Fulis*, and *Mandingos*. The *Jalofs* possess the middle of the country. The *Fulis* principal settlement is on both sides of the Senegal: great numbers of these people are also mixed with the *Mandingos*; which last are mostly settled on both sides the Gambia. The government of the *Jalofs* is represented as under a better regulation than can be expected from the common opinion we entertain of the negroes. We are told in Astley's Collection, "That the king has under him several ministers of state, who assist him in the exercise of justice. The grand jerafo is the chief justice through all the king's dominions, and goes in circuit from time to time to hear complaints and determine controversies. The king's treasurer exercises the same employment, and has under him alkairs, who are governors of towns or villages. That the kondi, or viceroy, goes the circuit with the chief justice, both to hear causes and inspect into the behaviour of the alkadi, or chief magistrate of every village in their several districts." Vascancelas, an author mentioned in the Collection, says, "the ancientest are preferred to be the prince's counsellors, who keep always about his person; and the men of most judgment and experience are the judges." The *Fulis* are settled on both sides of the river Senegal: their country, which is very fruitful and populous, extends near 400 miles from east to west. They are generally of a deep tawney complexion, appearing to bear some affinity to the Moors, whose country they join on the north: they are good farmers, and make great harvest of corn, cotton, tobacco, &c. and breed great numbers of cattle of all kinds. But the most particular account we have of these people is from Moore, who says †, "Some of these Fuli blacks, who dwell on both sides the river Gambia, are in subjection to the *Mandingos*, amongst whom they dwell, having been probably driven out of their country by war or famine. They have chiefs of their own, who rule with much moderation. Few of them will drink brandy, or any thing stronger than water and sugar, being strict Mahometans. Their form of government goes on easy, because the people are of a good quiet disposition, and so

well instructed in what is right, that a man who does ill is the abomination of all, and none will support him against the chief. In these countries the natives are not covetous of land, desiring no more than what they use; and as they do not plough with horses and cattle, they can use but very little; therefore the kings are willing to give the *Fulis* leave to live in their country, and cultivate their lands. If any of their people are known to be made slaves, all the *Fulis* will join to redeem them; they also support the old, the blind, the lame, amongst themselves; and as far as their abilities go, they supply the necessities of the *Mandingos*, great numbers of whom they have maintained in famine." The author, from his own observations, says, "They were rarely angry, and that he never heard them abuse one another."

The *Mandingos* are said by Mr Brue before mentioned, "to be the most numerous nation on the Gambia, besides which, numbers of them are dispersed over all these countries; being the most rigid Mahometans amongst the negroes, they drink neither wine nor brandy, and are politer than the other negroes. The chief of the trade goes through their hands. Many are industrious and laborious, keeping their grounds well cultivated, and breeding a good stock of cattle †. Every town has an alkadi, or governor, † Astley's Collect. P. 296. who has great power; for most of them having two common fields of clear ground, one for corn, and the other for rice, the alkadi appoints the labour of all the people. The men work the corn ground, and the women and girls the rice ground; and as they all equally labour, so he equally divides the corn amongst them; and in case any are in want, the others supply them. This alkadi decides all quarrels, and has the first voice in all conferences in town affairs." Some of these *Mandingos*, who are settled at Galem, far up the river Senegal, can read and write Arabic tolerably; and are a good hospitable people, who carry on a trade with the inland nations. "They are extremely populous in those parts, their women being fruitful, and they not suffering any person amongst them, but such as are guilty of crimes, to be made slaves." We are told from Jobson, "That the Mahometan negroes say their prayers thrice a-day. Each village has a priest who calls them to their duty. It is surprising (says the author), as well as commendable, to see the modesty, attention, and reverence they observe during their worship." He asked some of their priests the purport of their prayers and ceremonies; their answer always was, "that they adored God by prostrating themselves before him; that by humbling themselves they acknowledged their own insignificancy, and farther intreated him to forgive their faults, and to grant them all good and necessary things, as well as deliverance from evil." Jobson takes notice of several good qualities in these negro priests, particularly their great sobriety. They gain their livelihood by keeping school for the education of the children. The boys are taught to read and write. They not only teach school, but rove about the country, teaching and instructing, for which the whole country is open to them; and they have a free course through all places, though the kings may be at war with one another.

The three fore-mentioned nations practise several trades,

Guinea.

* Voyage to Guinea, p. 31, 34.

† Travels into distant parts of Africa, p. 198.

Guinea. trades, as smiths, potters, saddlers, and weavers. Their smiths work particularly neat in gold and silver, and make knives, hatchets, reaping hooks, spades, and shears to out iron, &c. Their potters make neat tobacco pipes, and pots to boil their food. Some authors say, that weaving is their principal trade: this is done by the women and girls, who spin and weave very fine cotton cloth, which they dye blue or black. Moore says, the Jalofs particularly make great quantities of the cotton cloth; their pieces are generally 27 yards long, and about nine inches broad, their looms being very narrow; these they sew neatly together, so as to supply the use of broad cloth.

It was in these parts of Guinea that M. Adanson, correspondent of the Royal Academy of Sciences at Paris, was employed from the year 1749 to the year 1753, wholly in making natural and philosophical observations on the country about the rivers Senegal and Gambia. Speaking of the great heats in Senegal, he says*, "it is to them that they are partly indebted for the fertility of their lands; which is so great, that, with little labour and care, there is no fruit nor grain but grows in great plenty."

Of the soil on the Gambia, he says, "it is rich and deep, and amazingly fertile; it produces spontaneously, and almost without cultivation, all the necessaries of life, grain, fruit, herbs, and roots. Every thing matures to perfection, and is excellent in its kind." One thing which always surprised him, was the prodigious rapidity with which the sap of trees repairs any loss they may happen to sustain in that country; "And I was never (says he) more astonished, than when landing four days after the locusts had devoured all the fruits and leaves, and even the buds of the trees, to find the trees covered with new leaves, and they did not seem to me to have suffered much."—"It was then (says the same author) the fish season; you might see them in shoals approaching towards land. Some of these shoals were 50 fathoms square, and the fish crowded together in such a manner, as to roll upon one another, without being able to swim. As soon as the negroes perceive them coming towards land, they jump into the water with a basket in one hand, and swim with the other. They need only to plunge and to lift up their basket, and they are sure to return loaded with fish." Speaking of the appearance of the country, and of the disposition of the people, he says, "which way soever I turned mine eyes on this pleasant spot, I beheld a perfect image of pure nature; an agreeable solitude, bounded on every side by charming landscapes; the rural situation of cottages in the midst of trees; the ease and indolence of the negroes, reclined under the shade of their spreading foliage; the simplicity of their dress and manners; the whole revived in my mind the idea of our first parents, and I seemed to contemplate the world in its primitive state. They are, generally speaking, very good-natured, sociable, and obliging. I was not a little pleased with this my first reception; it convinced me, that there ought to be a considerable abatement made in the accounts I had read and heard everywhere of the savage character of the Africans. I observed, both in the negroes and Moors great humanity and sociableness, which gave me strong hopes that I should be very safe amongst them, and meet with the success I desired in my inquiries af-

ter the curiosities of the country." He was agreeably amused with the conversation of the negroes, their fables, dialogues, and witty stories with which they entertain each other alternately, according to their custom. Speaking of the remarks which the natives made to him with relation to the stars and planets, he says, "it is amazing that such a rude and illiterate people should reason so pertinently in regard to those heavenly bodies; there is no manner of doubt, but that with proper instruments, and a good will, they would become excellent astronomers."

2. That part of Guinea known by the name of the *Grain and Ivory Coast* extends about 500 miles. The soil is said to be in general fertile, producing abundance of rice and roots; indigo and cotton thrive without cultivation, and tobacco would be excellent if carefully manufactured; they have fish in plenty; their flocks greatly increase; and their trees are loaded with fruit. They make a cotton cloth, which sells well on the coast. In a word, the country is rich, and the commerce advantageous, and might be greatly augmented by such as would cultivate the friendship of the natives. These are represented by some writers as a rude, treacherous people; whilst several other authors of credit give them a very different character, describing them as sensible, courteous, and the fairest traders on the coast of Guinea. In the Collection, they are said † to be averse to drinking to excess, and such as do are severely punished by the king's order. On inquiry why there is such a disagreement in the character given of these people, it appears, that though they are naturally inclined to be kind to strangers, with whom they are fond of trading, yet the frequent injuries done them by Europeans have occasioned their being suspicious and shy: the same cause has been the occasion of the ill treatment they have sometimes given to innocent strangers, who have attempted to trade with them. As the Europeans have no settlement on this part of Guinea, the trade is carried on by signals from the ships, on the appearance of which the natives usually come on board in their canoes, bringing their gold-dust, ivory, &c. which has given opportunity to some villanous Europeans to carry them off with their effects, or retain them on board till a ransom is paid. It is noted by some, that since the European voyagers have carried away several of these people, their mistrust is so great, that it is very difficult to prevail on them to come on board. Smith remarks, "As we passed along this coast, we very often lay before a town, and fired a gun for the natives to come off; but no soul came near us: at length we learnt by some ships that were trading down the coast, that the natives came seldom on board an English ship, for fear of being detained or carried off: yet at last some ventured on board; but if these chanced to spy any arms, they would all immediately take to their canoes, and make the best of their way home. They had then in their possession one Benjamin Cross, the mate of an English vessel, who was detained by them to make reprisals for some of their men, who had formerly been carried away by some English vessel." In the Collection we are told, "This villanous custom is too often practised, chiefly by the Bristol and Liverpool ships, and is a great detriment to the slave-trade on the windward coast." John Snock, mentioned in Rosman ‡, when

Guinea.

* Voyage to Senegal, &c. p. 303.

† Vol. ii. p. 56c.

‡ Description of Guinea, p. 44c.

Guinea.

when on the coast, wrote, "We cast anchor, but not one negro coming on board, I went on shore; and after having staid a while on the strand, some negroes came to me; and being desirous to be informed why they did not come on board, I was answered, that about two months before, the English had been there with two large vessels, and had ravaged the country, destroyed all their canoes, plundered their houses, and carried off some of their people, upon which the remainder fled to the inland country, where most of them were at that time; so that there being not much to be done by us, we were obliged to return on board. When I inquired after their wars with other countries, they told me they were not often troubled with them; but if any difference happened, they chose rather to end the dispute amicably than to come to arms.*" He found the inhabitants civil and good-natured. Speaking of the king of Rio Bestro, lower down the coast, he says, "He was a very agreeable, obliging man; and all his subjects are civil, as well as very laborious in agriculture and the pursuits of trade." Marchais † says, "That though the country is very populous, yet none of the natives (except criminals) are sold for slaves." Vaillant never heard of any settlement being made by the Europeans on this part of Guinea; and Smith remarks ‡, "That these coasts which are divided into several little kingdoms, and have seldom any wars, is the reason the slave-trade is not so good here as on the Gold and Slave Coast, where the Europeans have several forts and factories." A plain evidence this, that it is the intercourse with the Europeans, and their settlements on the coast, which gives life to the slave-trade.

3. Next adjoining to the Ivory Coast are those called the *Gold Coast* and the *Slave Coast*; authors are not agreed about their bounds, but their extent together along the coast may be about 500 miles. And as the policy, produce, and economy of these two kingdoms of Guinea are much the same, they shall be described together.

Here the Europeans have the greatest number of forts and factories; from whence, by means of the negro factors, a trade is carried on above 700 miles back in the inland country; where great numbers of slaves are procured, as well by means of the wars which arise amongst the negroes, or are fomented by the Europeans, as those brought from the back country. Here we find the natives more reconciled to the European manners and trade; but, at the same time, much more inured to war, and ready to assist the European traders in procuring loadings for the great number of vessels which come yearly on those coasts for slaves. This part of Guinea is agreed by historians to be, in general, extraordinary fruitful and agreeable; producing (according to the difference of the soil) vast quantities of rice and other grain, plenty of fruit and roots, palm wine and oil, and fish in great abundance, with much tame and wild cattle. Bosman, principal factor for the Dutch at D'Elmina, speaking of the country of Axim, which is situated towards the beginning of the Gold Coast, says, "The negro inhabitants are generally very rich, driving a great trade with the Europeans for gold: That they are industriously employed either in trade, fishing, or agriculture; but chiefly in the culture of rice, which grows here

in an incredible abundance, and is transported hence all over the Gold Coast: the inhabitants, in lieu, returning full fraught with millet, jamms, potatoes, and palm oil." The same author, speaking of the country of Ante, says, "This country, as well as the Gold Coast, abounds with hills, enriched with extraordinary high and beautiful trees; its valleys, betwixt the hills, are wide and extensive, producing in great abundance very good rice, millet, jamms, potatoes, and other fruits, all good in their kind." He adds, "In short, it is a land that yields its manurers as plentiful a crop as they can wish, with great quantities of palm wine and oil, besides being well furnished with all sorts of tame as well as wild beasts; but that the last fatal wars had reduced it to a miserable condition, and stripped it of most of its inhabitants." The adjoining country of Fetu, he says, "was formerly so powerful and populous, that it struck terror into all the neighbouring nations; but it is at present so drained by continual wars, that it is entirely ruined; there does not remain inhabitants sufficient to till the country, though it is so fruitful and pleasant that it may be compared to the country of Ante just before described; frequently (says our author), when walking through it before the last war, I have seen it abound with fine well built and populous towns, agreeably enriched with vast quantities of corn, cattle, palm wine, and oil. The inhabitants all apply themselves without any distinction to agriculture; some sow corn; others press oil, and draw wine from palm trees, with both which it is plentifully stored."

Smith gives much the same account of the before-mentioned parts of the Gold Coast; and adds, "the country about D'Elmina and Cape Coast is much the same for beauty and goodness, but more populous; and the nearer we come towards the Slave Coast, the more delightful and rich all the countries are, producing all sorts of trees, fruits, roots, and herbs, that grow within the torrid zone." Barbot also remarks*, with respect to the countries of Ante and Adom, "That the soil is very good and fruitful in corn and other produce; which it affords in such plenty, that besides what serves for their own use, they always export great quantities for sale: they have a competent number of cattle, both tame and wild, and the rivers are abundantly stored with fish; so that nothing is wanting for the support of life and to make it easy." In the Collection it is said, "That the inland people on that part of the coast employ themselves in tillage and trade, and supply the market with corn, fruit, and palm wine; the country producing such vast plenty of Indian corn, that abundance is daily exported as well by Europeans as blacks resorting thither from other parts." These inland people are said to live in great union and friendship, being generally well tempered, civil, and tractable; not apt to shed human blood, except when much provoked; and ready to assist one another. In the Collection it is said, "That the fishing business is esteemed on the Gold Coast next to trading; that those who profess it are more numerous than those of other employments. That the greatest number of these are at Kommendo, Mina, and Kormantin; from each of which places there go out every morning (Tuesday excepted, which is the Fetish day or day of rest), five, six, and sometimes eight hundred

Guinea.

* *Description of Guinea*, p. 441.

† *Astley's Collection*, vol. ii. p. 565.

‡ *Smith's Voyage to Guinea*, p. 512.

* *Barbot's Description of Guinea*, p. 154.

Guinea. canoes, from 13 to 14 feet long, which spread themselves two leagues at sea, each fisherman carrying in his canoe a sword, with bread, water, and a little fire on a large stone to roast fish. Thus they labour till noon, when the sea breeze blowing fresh, they return on the shore, generally laden with fish; a quantity of which the inland inhabitants come down to buy, which they sell again at the country markets."

Smith says, "The country about Acra, where the English and Dutch have each a strong fort, is very delightful, and the natives courteous and civil to strangers." He adds, "That this place seldom fails of an extraordinary good trade from the inland country, especially for slaves, whereof several are supposed to come from very remote parts, because it is not uncommon to find a Malayan or two amongst a parcel of other slaves. The Malay people are generally natives of Malacca, in the East Indies, situated several thousand miles from the Gold Coast." They differ very much from the Guinea negroes, being of a tawney complexion with long black hair.

Most parts of the Slave Coast are represented as equally fertile and pleasant with the Gold Coast. The kingdom of Whidah has been particularly noted by travellers. Smith and Bosman agree "That it is one of the most delightful countries in the world. The great number and variety of tall, beautiful, and shady trees, which seem planted in groves; the verdant fields everywhere cultivated, and no otherwise divided than by those groves, and in some places a small foot-path, together with a great number of villages, contribute to afford the most delightful prospect; the whole country being a fine, easy, and almost imperceptible ascent for the space of 40 or 50 miles from the sea. That the farther you go from the sea, the more beautiful and populous the country appears. That the natives were kind and obliging, and so industrious, that no place which was thought fertile could escape being planted, even within the hedges which inclose their villages. And that the next day after they had reaped, they sowed again."

Snelgrave also says, "The country appears full of towns and villages; and being a rich soil, and well cultivated, looks like an entire garden." In the Collection, the husbandry of the negroes is described to be carried on with great regularity. "The rainy season approaching, they go into the fields and woods, to fix on a proper place for sowing; and as here is no property in ground, the king's licence being obtained, the people go out in troops, and first clear the ground from bushes and weeds, which they burn. The field thus cleared, they dig it up a foot deep, and so let it remain for eight or ten days, till the rest of their neighbours have disposed their ground in the same manner. They then consult about sowing, and for that end assemble at the king's court the next Fetich day. The king's grain must be sown first. They then go again to the field, and give the ground a second digging, and sow their seed. Whilst "the king or governor's land is sowing, he sends out wine and flesh, ready dressed, enough to serve the labourers. Afterwards, they in like manner sow the ground allotted for their neighbours as diligently as that of the king's, by whom they are also feasted; and so continue to work in a body for the public benefit till

every man's ground is tilled and sowed. None but the king, and a few great men, are exempted from this labour. Their grain soon sprouts out of the ground. When it is about a man's height, and begins to ear, they raise a wooden house in the centre of the field, covered with straw, in which they set their children to watch their corn, and fright away the birds."

Bosman speaks in commendation of the civility, kindness, and great industry of the natives of Whidah. This is confirmed by Smith, who says, "The natives here seem to be the most gentleman-like negroes in Guinea, abounding with good manners and ceremony to each other. The inferior pay the utmost deference and respect to the superior, as do wives to their husbands, and children to their parents. All here are naturally industrious, and find constant employment; the men in agriculture, and the women in spinning and weaving cotton. The men, whose chief talent lies in husbandry, are unacquainted with arms; otherwise, being a numerous people, they could have made a better defence against the king of Dahomy, who subdued them without much trouble." According to the Collection, there are, throughout the Gold Coast, regular markets in all villages, furnished with provisions and merchandise, held every day in the week except Tuesday, whence they supply, not only the inhabitants, but the European ships. The negro women are very expert in buying and selling, and extremely industrious; for they will repair daily to market from a considerable distance, loaded like pack-horses, with a child perhaps at their back, and a heavy burden on their heads. After selling their wares, they buy fish and other necessaries, and return home loaded as they came. There is a market held at Sabi every fourth day, also a weekly one in the province of Apologua, which is so resorted to, that there are usually 5000 or 6000 merchants. Their markets are so well regulated and governed, that seldom any disorder happens; each species of merchandise and merchants have a separate place allotted them by themselves. The buyers may haggle as much as they will, but it must be without noise or fraud. To keep order, the king appoints a judge; who, with four officers well armed, inspects the markets, hears all complaints, and in a summary way decides all differences; he has power to seize and sell as slaves, all who are caught in stealing or disturbing the peace. In these markets are to be sold men, women, children, oxen, sheep, goats, and fowls of all kinds; European cloths, linen and woollen; printed calicoes, silk, grocery ware, china, gold-dust, iron in bars, &c. in a word, most sorts of European goods, as well as the produce of Africa and Asia. They have other markets, resembling our fairs, once or twice a-year, to which all the country repair; for they take care to order the day so in different governments as not to interfere with each other."

With respect to government, Smith says*, "that the Gold Coast and Slave Coast are divided into different districts, some of which are governed by their chiefs or kings: the others, being more of the nature of a commonwealth, are governed by some of the principal men, called *Cabeceros*; who Bosman says, are properly denominated *civil fathers*, whose province

Guinea.

Guinea. vince is to take care of the welfare of the city or village, and to appease tumults." But this order of government has been much broken since the coming of the Europeans. Both Bosman and Barbot mention murder and adultery to be severely punished on the coast, frequently by death; and robbery by a fine proportionable to the goods stolen.

The income of some of the kings is large. Bosman says, "that the king of Whidah's revenues and duties on things bought and sold are considerable; he having the tithes of all things sold in the market, or imported into the country." Both the above-mentioned authors say, the tax on slaves shipped off in this king's dominions, in some years, amounts to near 20,000.

Bosman tells us, "the Whidah negroes have a faint idea of a true God, ascribing to him the attributes of almighty power and omnipresence: but God, they say, is too high to condescend to think of mankind; wherefore he commits the government of the world to those inferior deities which they worship." Some authors say, the wisest of these negroes are sensible of their mistake in this opinion; but dare not forsake their own religion, for fear of the populace rising and killing them. This is confirmed by Smith, who says, "that all the natives of this coast believe there is one true God, the author of them and all things; that they have some apprehension of a future state; and that almost every village has a grove, or public place of worship, to which the principal inhabitants, on a set day, resort to make their offerings."

In the Collection it is remarked as an excellency in the Guinea government, "that however poor they may be in general, yet there are no beggars to be found amongst them; which is owing to the care of their chief men, whose province it is to take care of the welfare of the city or village, it being part of their office to see that such people may earn their bread by their labour; some are set to blow the smith's bellows, others to press palm oil, or grind colours for their mats, and sell provision in the markets. The young men are listed to serve as soldiers, so that they suffer no common beggar." Bosman ascribes a further reason for this good order*, viz. "that when a negro finds he cannot subsist, he binds himself for a certain sum of money, and the master to whom he is bound is obliged to find him necessaries; that the master sets him a sort of task, which is not in the least slavish, being chiefly to defend his master on occasions, or in sowing time to work as much as himself pleases."

* Bosman,
p. 119.

Adjoining to the kingdom of Whidah are several small governments, as Coto, great and small Popo, Atrah, &c. all situated on the Slave Coast, where the chief trade for slaves is carried on. These are governed by their respective kings, and follow much the same customs with those of Whidah, except that their principal living is on plunder and the slave-trade.

4. Next adjoining to the Slave Coast, is the kingdom of Benin, which, though it extends but about 170 miles on the sea, yet spreads so far inland as to be esteemed the most potent kingdom in Guinea. By accounts, the soil and produce appear to be in a great measure like those before described, and the natives are represented as a reasonable good-natured people. Artua says †, "they are a sincere, inoffensive people,

and do no injustice either to one another or to strangers." Smith confirms this account, and says, "that the inhabitants are generally very good-natured, and exceeding courteous and civil. When the Europeans make them presents, which in their coming thither to trade they always do, they endeavour to return them doubly." Bosman tells us, "that his countrymen the Dutch, who were often obliged to trust them till they returned the next year, were sure to be honestly paid their whole debts."

Guinea.

There is in Benin a considerable order in government; theft, murder, and adultery, being severely punished. Smith says, "their towns are governed by officers appointed by the king, who have power to decide in civil cases, and to raise the public taxes: but in criminal cases, they must send to the king's court, which is held at the town of Oedo or Great Benin. This town, which covers a large extent of ground, is about 60 miles from the sea." Barbot tells us, "that it contains 30 streets, 20 fathoms wide, and almost two miles long, commonly extending in a straight line from one gate to another; that the gates are guarded by soldiers; that in these streets markets are held every day, for cattle, ivory, cotton, and many sorts of European goods. This large town is divided into several wards or districts, each governed by its respective king of a street, as they call them, to administer justice, and to keep good order. The inhabitants are very civil and good-natured, condescending to what the Europeans require of them in a civil way." The same author confirms what has been said by others of their justice in the payment of their debts; and adds, "that they, above all other Guineans, are very honest and just in their dealings; and they have such an aversion for theft, that by the law of the country it is punished with death." We are told by the same author, "that the king of Benin is able upon occasion to maintain an army of 100,000 men; but that, for the most part, he does not keep 30,000." See the article BENIN.

5. The last division of Guinea from which slaves are imported, are the kingdoms of Congo and Angola: these lie to the south of Benin, extending with the intermediate land about 1200 miles on the coast. Great numbers of the natives of both these kingdoms profess the Christian religion, which was long since introduced by the Portuguese, who made early settlements in that country. See CONGO and ANGOLA.

In the Collection it is said, that both in Congo and Angola, the soil is, in general fruitful, producing great plenty of grain, Indian corn, and such quantities of rice, that it hardly bears any price, with fruits, roots, and palm oil in plenty. The natives are generally a quiet people, who discover a good understanding, and behave in a friendly manner to strangers, being of a mild conversation, affable, and easily overcome with reason. In the government of Congo, the king appoints a judge in every particular division, to hear and determine disputes and civil causes; the judges imprison and release, or impose fines, according to the rule of custom; but in weighty matters, every one may appeal to the king, before whom all criminal causes are brought, in which he giveth sentence; but seldom condemneth to death. The town of Leango stands in the midst of four lordships, which abound in

† Collect.
vol. iii.
p. 223.

Guinea.

corn, fruit, &c. Here they make great quantities of cloth of divers kinds, very fine and curious; the inhabitants are seldom idle; they even make needle-work caps as they walk in the streets. The slave-trade is here principally managed by the Portuguese, who carry it far up into the inland countries. They are said to send off from these parts 15,000 slaves each year. At Angola, about the tenth degree of south latitude, ends the trade for slaves.

As all these countries lie between the tropics, the air is excessively hot, especially from the beginning of September to the end of March; which, with the coolness of the nights, the frequent thick, stinking, sulphureous mists, and the periodical rains, when the flat country is overflowed, makes it very unhealthy, especially to Europeans. The natives, however, are little affected with the unwholesome air. According to Barbot, they keep much within doors in tempestuous times; and when exposed to the weather, their skins being suppled and pores closed by daily anointing with palm oil, the weather can make but little impression on them. They generally, therefore, enjoy a good state of health, and are able to procure to themselves a comfortable subsistence, with much less care and toil than is necessary in our more northern climate: which last advantage arises not only from the warmth of the climate, but also from the overflowing of the rivers, whereby the land is regularly moistened and rendered extremely fertile; and being in many places improved by culture, abounds with grain and fruits, cattle, poultry, &c. The earth yields all the year a fresh supply of food: Few clothes are requisite, and little art necessary in making them, or in the construction of their houses, which are very simple, principally calculated to defend them from the tempestuous seasons and wild beasts; a few dry reeds covered with mats serve for their beds. The other furniture, except what belongs to cookery, gives the women but little trouble; the moveables of the greatest among them amounting only to a few earthen pots, some wooden utensils, and gourds or calabashes; from these last, which grow almost naturally over their huts, to which they afford an agreeable shade, they are abundantly stocked with good clean vessels for most household uses, being of different sizes, from half a pint to several gallons.

The distempers the Europeans are subject to on this coast, are fevers, fluxes, and colics, which are occasioned by indifferent water and bad air; their settlements lying near the coast, where the fogs and steams arising from the ooze and salt-marshes, and the stinking fish the natives dry on the beach, corrupt the air, and render it fatal to foreigners. The most temperate men find it difficult to preserve their health; but a great many hasten their death by their intemperance, or negligence, exposing themselves to the cold air in the evening, after a very hot day. This sudden change, from one extreme to the other, has often very bad effects in hot climates.

Of mountains in Guinea, the most remarkable are those of Sierra Leon. The principal capes are those of Cape Blanco, Cape Verd, Cape Leon, Cape St Ann's, Cape Palmas, and Cape Three Points, Cape Formosa, Cape Monte, Cape St John, Cape Lopas, Cape Ledé, and Cape Negro. The chief bays are

VOL. X. Part I.

the Cyprian or Cintra bay, and the Bite of Guinea. Of the rivers, the most considerable are those of Co-anzo and Ambrisi, the Zaara, the Lunde, the Cameron, the Formosa, the Volta, the Sierra Leon, and the Sherbro. All these run from east to west (except the Volta, which runs from north to south), and fall into the Atlantic.

Besides gold, ivory, and slaves, Guinea affords indigo, wax, gum-senega, gum-tragacanth, and a variety of other gums and drugs.

The most ancient account we have of the country of the negroes, particularly that part situated on between the two great rivers of Senegal and Gambia, is from the writings of two ancient authors, one an Arabian, and the other a Moor. The first wrote in Arabic about the 12th century. His works, printed in that language at Rome, were afterwards translated into Latin, and printed at Paris under the patronage of the famous Thuanus chancellor of France, with the title of *Geographia Nubiensis*, containing an account of all the nations lying on the Senegal and Gambia. The other was written by John Leo, a Moor, born at Granada in Spain, before the Moors were totally expelled from that kingdom. He resided in Africa; but being on a voyage from Tripoli to Tunis, was taken by some Italian corsairs, who finding him possessed of several Arabian books, besides his own manuscripts, apprehended him to be a man of learning, and as such presented him to Pope Leo X. This pope encouraging him, he embraced the Romish religion, and his description of Africa was published in Italian. From these writings we gather, that after the Mahometan religion had extended to the kingdom of Morocco, some of the promoters of it crossing the sandy deserts of Numidia, which separate that country from Guinea, found it inhabited by men, who, though under no regular government, and destitute of that knowledge the Arabians were favoured with, lived in content and peace. The first author particularly remarks, "that they never made war, or travelled abroad, but employed themselves in tending their herds, or labouring in the ground." J. Leo says, p. 65. "That they lived in common, having no property in land, no tyrant nor superior lord, but supported themselves in an equal state, upon the natural produce of the country, which afforded plenty of roots, game, and honey. That ambition or avarice never drove them into foreign countries to subdue or cheat their neighbours. Thus they lived without toil or superfluities."—"The ancient inhabitants of Morocco, who wore coats of mail, and used swords and spears headed with iron, coming amongst these harmless and naked people, soon brought them under subjection, and divided that part of Guinea which lies on the rivers Senegal and Gambia into 15 parts; those were the 15 kingdoms of the negroes, over which the Moors presided, and the common people were negroes. These Moors taught the negroes the Mahometan religion, and arts of life; particularly the use of iron, before unknown to them. About the 14th century, a native negro, called *Heli Ischia*, expelled the Moorish conquerors; but though the negroes threw off the yoke of a foreign nation, they only changed a Libyan for a negro master. Heli Ischia himself becoming king, led the negroes on to foreign wars, and established himself in power over a very large

Guinea.

History of the Guinea trade.

Guinea. extent of country." Since Leo's time, the Europeans have had very little knowledge of those parts of Africa, nor do they know what became of his great empire. It is highly probable that it broke into pieces, and that the natives again resumed many of their ancient customs; for in the account published by Moore, in his travels on the river Gambia, we find a mixture of the Moorish and Mahometan customs, joined with the original simplicity of the negroes. It appears by accounts of ancient voyages, collected by Hackluit, Purchas, and others, that it was about 50 years before the discovery of America, that the Portuguese attempted to sail round Cape Bojador, which lies between their country and Guinea: this, after divers repulses occasioned by the violent currents, they effected; when landing on the western coasts of Africa, they soon began to make incursions into the country, and to seize and carry off the native inhabitants. As early as the year 1434, Alonzo Gonzales, the first who is recorded to have met with the natives, being on that coast, pursued and attacked a number of them, when some were wounded, as was also one of the Portuguese; which the author records as the first blood spilt by Christians in those parts. Six years after, the same Gonzales again attacked the natives and took 12 prisoners, with whom he returned to his vessels: he afterwards put a woman on shore, in order to induce the natives to redeem the prisoners; but the next day 150 of the inhabitants appeared on horses and camels, provoking the Portuguese to land; which they not daring to venture, the natives discharged a volley of stones at them, and went off. After this, the Portuguese still continued to send vessels on the coast of Africa: particularly we read of their falling on a village, whence the inhabitants fled, and, being pursued, 25 were taken; "he that ran best (says the author), taking the most." In their way home they killed some of the natives, and took 55 more prisoners. Afterwards Dinisanes Dagrama, with two other vessels, landed on the island Arguin, where they took 54 Moors; then running along the coast 80 leagues farther, they at several times took 50 slaves; but here seven of the Portuguese were killed. Then being joined by several other vessels, Dinisanes proposed to destroy the island, to revenge the loss of the seven Portuguese; of which the Moors being apprised, fled, so that no more than 12 were found, whereof only four could be taken, the rest being killed, as also one of the Portuguese." Many more captures of this kind on the coast of Barbary and Guinea are recorded to have been made in those early times by the Portuguese; who, in the year 1481, erected their first fort at D'Elmina on that coast, from whence they soon opened a trade for slaves with the inland parts of Guinea.

From the foregoing accounts, it is undoubted, that the practice of making slaves of the negroes owes its origin to the early incursions of the Portuguese on the coast of Africa, solely from an inordinate desire of gain. This is clearly evidenced from their own historians, particularly Cada Mosto, about the year 1455, who writes*, "That before the trade was settled for purchasing slaves from the Moors at Arguin, sometimes four, and sometimes more Portuguese vessels, were used to come to that gulf, well armed; and landing by

Guinea. night, would surprise some fishermen's villages: that they even entered into the country, and carried off Arabs of both sexes, whom they sold in Portugal." And also, "That the Portuguese and Spaniards, settled on four of the Canary islands, would go to the other island by night, and seize some of the natives of both sexes, whom they sent to be sold in Spain."

After the settlement of America, those devastations, and the captivating the miserable Africans, greatly increased.

Anderson, in his History of Trade and Commerce, p. 336. speaking of what passed in the year 1508, writes, "That the Spaniards had by this time found that the miserable Indian natives, whom they had made to work in their mines and fields, were not so robust and proper for those purposes as negroes brought from Africa: wherefore they, about that time, began to import negroes for that end into Hispaniola, from the Portuguese settlements on the Guinea coasts; and also afterwards for their sugar-works."

It was about the year 1551, towards the latter end of the reign of Edward VI. when some London merchants sent out the first English ship on a trading voyage to the coast of Guinea. This was soon followed by several others to the same parts; but the English not having then any plantations in the West India, and consequently no occasion for negroes, such ships traded only for gold, elephants teeth, and Guinea pepper. This trade was carried on at the hazard of losing their ships and cargoes, if they had fallen into the hands of the Portuguese, who claimed an exclusive right of trade, on account of the several settlements they had made there. In 1553, we find Captain Thomas Windham trading along the coast with 140 men, in three ships, and sailing as far as Benin, which lies about 3000 miles down the coast, to take in a load of pepper. Next year John Loke traded along the coast of Guinea, as far as D'Elmina, when he brought away considerable quantities of gold and ivory. He speaks well of the natives, and says, "That whoever will deal with them must behave civilly, for they will not traffic if ill used." In 1555, William Towerson traded in a peaceable manner with the natives, who made complaint to him of the Portuguese, who were then settled in their castle at D'Elmina; saying, "They were bad men; who made them slaves if they could take them, putting irons on their legs."

This bad example of the Portuguese was soon followed by some evil-disposed Englishmen: for the same Captain Towerson relates*, "That in the course of his voyage, he perceived the natives near D'Elmina unwilling to come to him, and that he was at last attacked by them; which he understood was done in revenge for the wrong done them the year before by one Captain Gainsh, who had taken away the negro captain's son and three others, with their gold, &c. This caused them to join the Portuguese, notwithstanding their hatred of them, against the English." The next year Captain Towerson brought these men back again; whereupon the negroes showed him much kindness. Quickly after this, another instance of the same kind occurred in the case of Captain George Fenner, who being on the coast with three vessels, was also attacked by the negroes, who wounded several of his people, and violently carried three of his men to their town. The

* Collection, vol. 1. p. 576.

Guinea. The captain sent a messenger, offering any thing they desired for the ransom of his men: but they refused to deliver them; letting him know, "That three weeks before, an English ship, which came into the road, had carried off three of their people; and that till they were brought again, they would not restore his men, even though they should give their three ships to release them." It was probably the evil conduct of these and some other Englishmen which was the occasion of what is mentioned in Hill's Naval History, viz. "That when Captain Hawkins returned from his first voyage to Africa, Queen Elizabeth sent for him, when she expressed her concern, lest any of the African negroes should be carried off without their free consent; which she declared would be detestable, and would call down the vengeance of heaven upon the undertakers." Hawkins made great promises, which nevertheless he did not perform; for his next voyage to the coast appears to have been principally calculated to procure negro slaves, in order to sell them to the Spaniards in the West Indies; which occasioned the same author to use these remarkable words: "Here began the horrid practice of forcing the Africans into slavery; an injustice and barbarity which, so sure as there is vengeance in heaven for the worst of crimes, will some time be the destruction of all who act or who encourage it." This Captain Hawkins, afterwards Sir John Hawkins, seems to have been the first Englishman who gave public countenance to this wicked traffic: for Anderson, before mentioned, at p. 401. says, "That in the year 1562, Captain Hawkins, assisted by subscription of sundry gentlemen, now fitted out three ships; and having learnt that negroes were a very good commodity in Hispaniola, he sailed to the coast of Guinea, took in negroes, and sailed with them for Hispaniola, where he sold them, and his English commodities, and loaded his three vessels with hides, sugar, ginger, &c. with which he returned home anno 1563, making a prosperous voyage." As it proved a lucrative business, the trade was continued both by Hawkins and others, as appears from the Naval Chronicle, p. 55.: where it is said, "That on the 18th of October 1564, Captain John Hawkins, with two ships of 700 and 140 tons, sailed for Africa; that on the 8th of December they anchored to the south of Cape Verd, where the captain manned the boat, and sent 80 men in armour into the country, to see if they could take some negroes; but the natives flying from them, they returned to their ships, and proceeded farther down the coast. Here they staid certain days, sending their men ashore, in order (as the author says) to burn and spoil their towns and take the inhabitants. The land they observed to be well cultivated, there being plenty of grain and fruit of several sorts, and the towns prettily laid out. On the 25th, being informed by the Portuguese of a town of negroes called *Bymba*, where there was not only a quantity of gold, but 140 inhabitants, they resolved to attack it, having the Portuguese for their guide; but by mismanagement they took but ten negroes, having seven of their own men killed and 27 wounded. They then went farther down the coast; when having procured a number of negroes, they proceeded to the West Indies, where they sold them to the Spaniards." And in the same Naval Chronicle, at p. 76. it is said, "That

in the year 1567, Francis Drake, before performing his voyage round the world, went with Sir John Hawkins in his expedition to the coast of Guinea, where taking in a cargo of slaves, they determined to steer for the Caribbee islands." How Queen Elizabeth suffered so grievous an infringement of the rights of mankind to be perpetrated by her subjects, and how she was persuaded, about the 30th year of her reign, to grant patents for carrying on a trade from the north part of the river Senegal to 100 leagues beyond Sierra Leona, which gave rise to the African Company, * See Com. is hard to account for, any otherwise than that it ^{arose from the misrepresentation made to her of the} ^{vol. iii.} ^{p. 225.} ^{216.} ^{Collection,} ^{p. 164.} situation of the negroes, and of the advantages it was pretended they would reap from being made acquainted with the Christian religion. This was the case of Louis XIII. of France: who, Labat, in his account of the isles of America, tells us, "was extremely uneasy at a law by which the negroes of his colonies were to be made slaves; but it being strongly urged to him as the readiest means of their conversion to Christianity, he acquiesced therewith." Nevertheless, some of the Christian powers did not so easily give way in this matter: for we find †, "That Cardinal Cibo, one of the pope's principal ministers of state, wrote a letter on behalf of the college of cardinals, or great council at Rome, to the missionaries in Congo, complaining that the pernicious and abominable abuse of selling slaves was yet continued; requiring them to remedy the same if possible; but this the missionaries saw little hopes of accomplishing, by reason that the trade of the country lay wholly in slaves and ivory."

It has been urged in justification of this trade, that by purchasing the captives taken in battle, they save the lives of so many human creatures, who otherwise would be sacrificed to the implacable revenge of the victors. But this pretence has been refuted by an appeal to reason and fact. For if the negroes apprehended they should be cruelly put to death if they were not sent away; why, it is asked, do they manifest such reluctance and dread as they generally do, at being brought from their native country? Smith, in his Account, p. 28. says, "The Gambians abhor slavery, and will attempt any thing, though ever so desperate, to avoid it." And Thomas Philips, in his account of a voyage he performed to the coast of Guinea, writes, "They (the negroes) are so loth to leave their own country, that they have often leaped out of the canoe, boat, or ship, into the sea, and kept under water till they were drowned, to avoid being taken up." But had the fact even been otherwise, the above plea is urged with an extreme bad grace, when it is notorious that the very wars said to be productive of such cruelty were fomented by the infamous arts of the Europeans. From the foregoing accounts, as well as other authentic publications of this kind, it appears, that it was the unwarrantable lust of gain which first stimulated the Portuguese, and afterwards other Europeans, to engage in this horrid traffic. By the most unquestionable relations of those early times, the natives were an inoffensive people, who, when civilly used, traded amicably with the Europeans. It is recorded of those of Benin, the largest kingdom in Guinea, that they were a gentle, loving people; and Reynold says, "They found more sincere proofs of

Guinea. love and good will from the natives, than they could find from the Spaniards and Portuguese, even though they had relieved them from the greatest misery." And from the same relations there is no reason to think otherwise, but that they generally lived in peace amongst themselves: there occurring no accounts of any wars at that early period, nor of any sale of captives taken in battle.

In fact, it was long after the Portuguese had made a practice of violently forcing the natives of Africa into slavery, that we read of the different negro nations making war upon each other, and selling their captives. And probably this was not the case, till those bordering on the coast, who had been used to supply the vessels with necessaries, had become corrupted by their intercourse with the Europeans, and were excited by drunkenness and avarice to join them in carrying on those wicked schemes, by which those unnatural wars were perpetrated, the inhabitants kept in continual alarms, the country laid waste, and, as Moore expresses it, "infinite numbers sold into slavery." But that the Europeans are the principal cause of these devastations, is particularly evidenced by one whose connection with the trade would rather induce him to represent it in the fairest colours, viz. Captain Smith, the person sent in the year 1726, by the African company, to survey their settlements; who, from the information he received of one of the factors who had resided ten years in that country, says, "That the discerning natives account it their greatest unhappiness, that they were ever visited by the Europeans*.—That we Christians introduced the traffic of slaves; and that before our coming they lived in peace."

* Smith,
p. 166.

† Collection,
vol. ii.
p. 98.

‡ p. 31.

In the accounts relating to the African trade, we find this melancholy truth farther asserted by some of the principal directors in the different factories: particularly A. Brue says †, "That the Europeans were far from desiring to act as peace-makers amongst the negroes; which would be acting contrary to their interest, since the greater the wars, the more slaves were procured." And William Bosman also remarks ‡, "That one of the former commanders gave large sums of money to the negroes of one nation, to induce them to attack some of the neighbouring nations; which occasioned a battle which was more bloody than the wars of the negroes usually are." This is confirmed by J. Barbot, who says, "That the country of D'Elmina, which was formerly very powerful and populous, was in his time so much drained of its inhabitants by the intestine wars fomented among the negroes by the Dutch, that there did not remain inhabitants enough to till the country."

It has also been advanced as an argument in favour of keeping the negroes in bondage, that there are slaves in Guinea, and that those amongst us might be so in their own country. Not to dwell upon the inconsistency of our giving any countenance to slavery, because the Africans, whom we esteem a barbarous and savage people, allow of it, and perhaps the more from our example; the very circumstance stated, when inquired into, must afford cause of blushing, rather than serve as a palliation of such iniquitous conduct: for it will appear, that the slavery endured in Guinea is by no means so grievous as that in the colonies. Captain Moore, speaking of the natives living on the river Gam-

bia, says, "That some of the negroes have many house slaves, which are their greatest glory; that those slaves live so well and easy, that it is sometimes a hard matter to know the slaves from their masters or mistresses. And that though in some parts of Africa they sell their slaves born in the family, yet on the river Gambia they think it a very wicked thing." The author adds, "He never heard of but one that ever sold a family slave, except for such crimes as they would have been sold for if they had been free." And in Astley's Collection, speaking of the customs of the negroes in that large extent of country farther down the coast, particularly denominated the *Coast of Guinea*, it is said, "They have not many slaves on the coast: none but the king or nobles are permitted to buy or sell any; so that they are allowed only what are necessary for their families or tilling the ground." The same author adds, "That they generally use their slaves well, and seldom correct them."

Guinea.

From the foregoing accounts of the natural disposition of the negroes, and the fruitfulness of most parts of Guinea, which are confirmed by authors of candour, who have written from their own knowledge, it may well be concluded, that the negroes acquaintance with the Europeans might have been a happiness to them: but these, forgetful of their duty as men and Christians, have conducted themselves in so iniquitous a manner; as must necessarily raise in the minds of the thoughtful and well-disposed negroes the utmost scorn and detestation of the very name of Christians. All other considerations have given way to an insatiable desire of gain, which has been the principal and moving cause of the most detestable and barbarous scene that was perhaps ever acted upon the face of the earth; instead of making use of that superior knowledge with which the Almighty, the common Parent of mankind, had favoured them, to strengthen the principle of peace and good will in the breasts of the incautious negroes, the Europeans have, by their bad example, led them into excess of drunkenness, debauchery, and avarice: whereby every passion of corrupt nature being inflamed, they have been easily prevailed upon to make war and captivate one another, as well to furnish means for the excesses they had been habituated to, as to satisfy the greedy desire of gain in their profligate employers; who to this intent have furnished them with prodigious quantities of arms and ammunition. Thus they have been hurried into confusion, distress, and all the extremities of temporal misery; every thing, even the power of their kings, has been made subservient to this wicked purpose; for instead of being protectors of their subjects, some of those rulers, corrupted by the excessive love of spirituous liquors, and the tempting baits laid before them by the factors, have invaded the liberties of their unhappy subjects, and are become their oppressors.

Here it may be necessary to observe, that the accounts we have of the inhabitants of Guinea are chiefly given by persons engaged in the trade, who, from self-interested views, have described them in such colours as were least likely to excite compassion and respect, and endeavoured to reconcile so manifest a violation of the rights of mankind to the minds of the purchasers; yet they cannot but allow the negroes to be possessed of some good qualities, though they con-

Guinea.

trive as much as possible to cast a shade over them. A particular instance of this appears in Astley's Collection, vol. ii. p. 73; where the author, speaking of the Mandingos settled at Galem, which is situated 900 miles up the Senegal, after saying that they carry on a commerce to all the neighbouring kingdoms, and amass riches, adds, "That excepting the vices peculiar to the blacks, they are a good sort of people, honest, hospitable, just to their word, laborious, industrious, and very ready to learn arts and sciences." Here it is difficult to imagine what vices can be peculiarly attendant on a people so well disposed as the author describes these to be. With respect to the charge some authors have brought against them, as being void of all natural affection, it is frequently contradicted by others. In vol. ii. of the Collection, p. 275. and 629. the negroes of North Guinea and the Gold Coast are said to be fond of their children, whom they love with tenderness. And Bosman says, p. 340. "Not a few in his country (viz. Holland) fondly imagine, that parents here sell their children, men their wives, and one brother the other: but those who think so, deceive themselves; for this never happens on any other account but that of necessity, or some great crime." The same is repeated by J. Barbot, p. 326. and also confirmed by Sir Hans Sloane in the introduction to his natural history of Jamaica; where, speaking of the negroes, he says, "they are usually thought to be haters of their own children; and therefore it is believed that they sell and dispose of them to strangers for money: but this is not true; for the negroes of Guinea being divided into several captainships, as well as the Indians of America, have wars; and besides those slain in battle, many prisoners are taken, who are sold as slaves, and brought thither: but the parents here, although their children are slaves for ever, yet have so great love for them, that no masters dare sell or give away one of their little ones unless they care not whether their parents hang themselves or not." J. Barbot, speaking of the occasion of the natives of Guinea being represented as a treacherous people, ascribes it to the Hollanders (and doubtless other Europeans) usurping authority, and fomenting divisions between the negroes. At p. 110. he says, "It is well known that many of the European nations, trading amongst these people, have very unjustly and inhumanly, without any provocation, stolen away, from time to time, abundance of the people, not only on this coast, but almost everywhere in Guinea, who have come on board their ships in a harmless and confiding manner: these they have in great numbers carried away, and sold in the plantations, with other slaves which they had purchased." And although some of the negroes may be justly charged with indolence and supineness, yet many others are frequently mentioned by authors as a careful, industrious, and even laborious people.

By an inquiry into the laws and customs formerly in use, and still in force among the negroes, particularly on the Gold Coast, it will be found, that provision was made for the general peace, and for the safety of individuals; even in W. Bosman's time, long after the Europeans had established the slave-trade, the natives were not publicly enslaved, any otherwise than in punishment for crimes, when prisoners of war, or by a

violent exertion of the power of their corrupted kings. Where any of the natives were stolen in order to be sold to the Europeans, it was done secretly, or at least only connived at by those in power; this appears from Barbot and Bosman's account of the matter, both agreeing that man-stealing was not allowed on the Gold Coast. The first says, "Kidnapping or stealing of human creatures is punished there, and even sometimes with death." And Bosman, whose long residence on the coast enabled him to speak with certainty, says, "That the laws were severe against murder, thievery, and adultery;" and adds, "That man-stealing was punished on the Gold Coast with rigid severity, and sometimes with death itself." Hence it may be concluded, that the sale of the greatest part of the negroes to the Europeans is supported by violence, in defiance of the laws, though the knavery of their principal men, who (as is too often the case with those in European countries), under pretence of encouraging trade, and increasing the public revenue, disregard the dictates of justice, and trample upon those liberties which they are appointed to preserve.

Moore also mentions man-stealing as being discountenanced by the negro governments on the river Gambia; and speaks of the enslaving the peaceable inhabitants, as a violence which only happens under a corrupt administration of justice. He says, "The kings of that country generally advise with their head men, scarcely doing any thing of consequence without consulting them first, except the king of Barsailay, who being subject to hard drinking, is very absolute. It is to this king's insatiable thirst for brandy, that his subjects freedoms and families are in so precarious a situation. Whenever this king wants goods or brandy, he sends a messenger to the English governor at James Fort, to desire he would send a sloop there with a cargo: *this news being not at all unwelcome*, the governor sends accordingly; against the arrival of the sloop, the king goes and ransacks some of his enemies towns, seizing the people, and selling them for such commodities as he is in want of, which commonly are brandy, guns, powder, balls, pistols, and cutlasses, for his attendants and soldiers; and coral and silver for his wives and concubines. In case he is not at war with any neighbouring king, he then falls upon one of his own towns, which are numerous, and uses them in the same manner. He often goes with some of his troops by a town in the day time, and returning in the night, sets fire to three parts of it, and putting guards at the fourth, there seizes the people as they run out from the fire; he ties their arms behind them, and marches them either to Joar or Cohone, where he sells them to the Europeans."

M. Brue, the French director, gives much the same account, and says, "That, having received goods, ^{astley} he wrote to the king, that if he had a sufficient number of slaves, he was ready to trade with him. This prince, as well as the other negro monarchs, has always a sure way of supplying his deficiencies, by selling his own subjects, for which they seldom want a pretence. The king had recourse to this method, by seizing 300 of his own people, and sent word to the director that he had the slaves ready to deliver for the goods." It seems the king wanted double the quantity of goods which

Guinea.

Guinea, which the factor would give him for these 300 slaves; but the factor refusing to trust him as he was already in the company's debt, and perceiving that this refusal had put the king much out of temper, he proposed that he should give him a license for taking so many more of his people as the goods he still wanted were worth: but this the king refused, saying, "It might occasion a disturbance among his subjects." Except in the above instance, and some others, where the power of the negro kings is unlawfully exerted over their subjects, the slave-trade is carried on in Guinea with some regard to the laws of the country, which allow of none to be sold but prisoners taken in their national wars, or people adjudged to slavery in punishment for crimes; but the largeness of the country, the number of kingdoms or commonwealths, and the great encouragement given by the Europeans, afford frequent pretences and opportunities to the bold designing profligates of one kingdom, to surprise and seize upon not only those of a neighbouring government, but also the weak and helpless of their own; and the unhappy people taken on those occasions, are, with impunity, sold to the Europeans. These practices are doubtless disapproved of by the most considerate amongst the negroes; for Bosman acquaints us, that even their rational wars are not agreeable to such. He says, "If the person who occasioned the beginning of the war be taken, they will not easily admit him to ransom, though his weight of gold should be offered, for fear he should in future form some new design against their repose."

We shall conclude this article with the following account of the shocking methods used in the carrying on of the slave-trade, as described by factors of different nations,

* *Asley,*
vol. ii p. 28.

Mr Moore *, factor for the English African Company on the river Gambia, writes, "That there are a number of negro traders, called *foncoes*, or merchants, who follow the slave-trade as a business; their place of residence is so high up the country as to be six weeks travel from James Fort, which is situated at the mouth of that river. These merchants bring down elephants teeth, and in some years 2000 slaves, most of which, they say, are prisoners taken in war. They buy them from the different princes who take them; many of them are Bumbrongs and Petcharies; nations who each of them have different languages, and are brought from a vast way inland. Their way of bringing them is tying them by the neck with leather thongs, at about a yard distant from each other, 30 or 40 in a string, having generally a bundle of corn or elephants teeth upon each of their heads. In their way from the mountains, they travel through very great woods, where they cannot for some days get water; so they carry in skin bags enough to support them for a time. I cannot (adds Moore) be certain of the number of merchants who follow this trade, but there may, perhaps, be about 100, who go up into the inland country with the goods which they buy from the white men, and with them purchase, in various countries, gold, slaves, and elephants teeth. Besides the slaves which the merchants bring down, there are many bought along the river: These are either taken in war, as the former are, or men condemned for crimes; or else people stolen, which is very frequent.—Since the

slave-trade has been used, all punishments are changed into slavery; there being an advantage on such condemnation, they strain for crimes very hard, in order to get the benefit of selling the criminal."

John Barbot, the French factor, in his account of the manner by which the slaves are procured, says, "The slaves sold by the negroes are for the most part prisoners of war, or taken in the incursions they make into their enemies territories; others are stolen away by their neighbours, when found abroad on the road, or in the woods; or else in the corn-fields, at the time of the year when their parents keep them there all the day to scare away the devouring small birds." Speaking of the transactions on that part of Guinea called the *Slave Coast*, where the Europeans have the most factories, and from whence they bring away much the greatest number of slaves, the same author says, "The inhabitants of Coto do much mischief in stealing those slaves they sell to the Europeans from the upland country.—That the inhabitants of Popo excel the former; being endowed with a much larger share of courage, they rob more successfully, by which means they increase their riches and trade." The author particularly remarks, "That they are encouraged in this practice by the Europeans: sometimes it happens, according to the success of their inland excursions, that they are able to furnish 200 slaves or more in a few days." And he says, "The blacks of Fida, or Whidah, are so expeditious in trading for slaves, that they can deliver 1000 every month."—"If there happens to be no stock of slaves there, the factor must trust the blacks with his goods, to the value of 150l. or 200l. which goods they carry up into the inland country to buy slaves, at all markets for above 600 miles up the country, where they are kept like cattle in Europe; the slaves sold there being generally prisoners of war, taken from their enemies like other booty, and perhaps some few sold by their own countrymen, in extreme want, or upon a famine, as also some as a punishment of heinous crimes." So far Barbot's account. That given by Bosman is as follows: "When the slaves which are brought from the inland countries come to Whidah, they are put in prison together; when we treat concerning buying them, they are all brought out together in a large plain, where, by our surgeons, they are thoroughly examined, and that naked, both men and women, without the least distinction or modesty. Those which are approved as good, are set on one side; in the meanwhile a burning iron, with the arms or name of the company, lies in the fire, with which ours are marked on the breast. When we have agreed with the owners of the slaves, they are returned to their prisons; where, from that time forward, they are kept at our charge, and cost us twopence a-day each slave, which serves to subsist them like criminals on bread and water; so that to save charges, we send them on board our ships the very first opportunity; before which, their masters strip them of all they have on their backs, so that they come on board stark naked, as well women as men. In which condition they are obliged to continue, if the master of the ship is not so charitable (which he commonly is) as to bestow something on them to cover their nakedness. Six or seven hundred are sometimes put on board a vessel, where they lie as close

Guinea.

Guinea: close together as it is possible for them to be crowded (A).²²

When the great income which arises to the negro kings on the Slave Coast, from the slaves brought through their several governments to be shipped on board the European vessels, is considered, we have no cause to wonder that they give so great a countenance to that trade. Bozman says, "That each ship which comes to Whidah to trade, reckoning one with another, either by toll, trade, or custom, pays about 400l. and sometimes 50 ships come hither in a year." Barbot confirms the same, and adds, "That in the neighbouring kingdom of Ardah the duty to the king is the value of 70 or 80 slaves for each trading ship;" which is near half as much more as at Whidah. Nor can the Europeans concerned in the trade, with any degree of propriety, blame the African kings for countenancing it, while they continue to send vessels on purpose to take in the slaves which are thus stolen, and that they are permitted, under the sanction of national laws, to sell them to the colonies.

The slave-trade, indeed, was long considered as disgraceful to an enlightened age; and in this country a spirit arose which seemed bent on annihilating it altogether, or so changing the nature of it as to blend humanity with policy. During the session 1788, the philanthropy of parliament, supported by that of the nation, paid a very particular attention to this odious branch of traffic. It was, however, a subject of too comprehensive a nature, and too materially connected with our African commerce at large and our West Indian colonies, to come to an immediate decision upon it. Parliament, therefore, was obliged to content itself for that time with a temporary bill to regulate the shipping and carrying slaves in British vessels from those coasts. The public attention was afterwards kept awake by a great variety of publications on both sides of the question; and the final arrangement of this important business, in which the honour of the British commerce and the British character, as well as the happiness of millions of our sable African brethren, is involved, was expected to take place during the session 1791. This humane measure was then unsuccessful; but having been repeatedly brought forward and discussed, the final abolition was agreed to by the legislature in the year 1806.

After the abolition was carried in parliament (in 1807), a number of gentlemen who had been most active in promoting that measure, formed themselves into a society under the name of the African Institution. Their intention was to follow up the abolition by plans for diffusing civilization among the inhabitants of Western Africa. In the prosecution of this object, warned by the fate of the Sierra Leon Company, they kept clear of all commercial enterprises. They sent agents, however, to Sierra Leon to supply them with information. They have encouraged individuals to study the Arabic and other languages spoken in Guinea, as a means of spreading more accurate ideas here re-

garding the inhabitants, and the productions of the country. They have sent out African youths, previously trained in Britain, to instruct their countrymen in the more simple and useful branches of elementary knowledge, and in some of the common arts. They have also sent out cotton seed and other useful plants, with instructions as to the mode of culture; and what was of no less importance, they were sedulously active in detecting all violations of the acts for the abolition of the slave trade, which they justly considered as the greatest obstruction to the civilization of Western Africa. It appears, that under their auspices some progress has been made in introducing peaceful habits and useful arts at Sierra Leon, and in some part of the neighbouring country; but the continuance of the slave trade, by Spain and Portugal, has presented a formidable obstacle to their benevolent attempts; and at present we believe the supporters of the institution are less sanguine in their hopes than they were at the commencement. See AFRICA, SUPPLEMENT.

New GUINEA, or *Papua*, a long and narrow island of the East Indies, which is yet but imperfectly known. It was supposed to be connected with New Holland, until Captain Cook discovered the strait which separates them. New Guinea, including Papua, its north-western part (which according to Bougainville's conjecture is separated from it by a strait), reaches from the equator to the 12th degree of south latitude, and from 131 to 150 degrees east longitude; in one part it does not appear to be above 50 miles broad. It was first visited by an European ship in 1529. Saavedra, a Portuguese, who made the discovery of the north-west part of this country, called it *Terra de Papuas*, or *Papas*. Van Schouten, a Dutch discoverer, afterwards gave the name of *New Guinea* to its south-western part. Admiral Roggewain also touched here; and before him Dampier, 1st January 1700. Captain Cook made the coast of New Guinea, in latitude 6 degrees 15 minutes, longitude 138 east, on the 3d of September, and landed in the pinnace, accompanied by Mr Banks, Dr Solander, nine of the ship's crew, and servants well armed, and leaving two seamen to take care of the boat, advanced some little way up the country; but coming to the skirts of a thick wood, they judged it prudent to proceed no farther, lest they should fall into an ambuscade of the natives, and their retreat to the boat be cut off. Having advanced about a quarter of a mile from the boat, three Indians rushed out of the wood with a hideous shout; they threw their darts, and showed such a hostile disposition, that the party, to prevent the destruction of these people, returned to the boat, as they had no intention forcibly to invade their country, either to gratify their appetites or curiosity, and it was evident nothing could be done upon friendly terms. When they got on board the boat, they rowed along the shore, and the number of Indians assembled seemed to be between 60 and 100. They made much the same appearance as the New Hollanders, being stark naked, and their hair cropped short. All the while they were shouting

Guinea.

(A) Here it is necessary to observe, that the number of slaves to be taken on board British ships was regulated by law, for some before the final abolition.

Guinea.

shouting defiance, and throwing something out of their hand which burnt exactly like gunpowder, but made no report; what these fires were, or for what purpose intended, could not be guessed at; those who discharged them had in their hands a short piece of stick, possibly a hollow cane, which they swung sidewise from them, and immediately fire and smoke issued, exactly resembling the discharge of a musket, and of no longer duration. This wonderful phenomenon was observed from the ship; and the deception was so great, that the people on board thought they had fire-arms; and even in the boat, if they had not been so near as that they must have heard the report, if there had been any, they should have thought they had been firing volleys. After looking at them attentively for some time, without taking any notice of their flashing and vociferation, the sailors fired some muskets over their heads. Upon hearing the balls rattle among the trees, they walked leisurely away, and the boat returned to the ship. Upon examining some weapons which the natives had thrown, they were found to be light darts, about four feet long, very ill made, of a reed or bamboo cane, and pointed with hard wood in which there were many barbs. They were discharged with great force, for at 60 yards distance they went beyond the party; but in what manner they were thrown could not be exactly seen. But the general opinion was, that they were thrown with a stick in the manner practised by the New Hollanders.

The land here is very low, as is every other part of the coast; but it is covered with a luxuriance of wood and herbage that can scarcely be conceived. Here the cocoa-nut, plantain, and bread-fruit, flourish in the highest perfection.

We are very little acquainted with the natural history of this country; but its zoology is worthy of attention, from its striking and romantic nature. It seems to be the peculiar residence of the beautiful and singular birds of Paradise, of which Mr Pennant has enumerated about 12 species. They are conjectured to breed here, but are generally taken in the neighbouring islands of Arros, to which they retire during the wet monsoon, in flocks of 30 or 40. Their cry, during their flight, has a strong resemblance to that of a starling; but when surprised with a strong gale, they croak like ravens, and mount into the superior regions of the air. Their food seems to be berries, or, as some think, nutmegs and butterflies. They are shot with blunt arrows, or taken with viscus or bird-lime. Here likewise are most elegant parrots and lories; and the crowned pigeon is said to be equal in size to a turkey.

Added to these are the islands of Waijoo and Salwatti, Arros and Timorland, the first of which is of considerable magnitude, containing about 100,000 inhabitants; the second is also populous, but they are more ferocious than the people of Waijoo; the production of the third is chiefly sago, and the inhabitants sell captives at Banda, which they seize on the main land. Timorland is of considerable extent, but so very little known to geographers, that no particular account can be given of it.

GUINEA, a gold coin, struck and current in Britain. The value or rate of guineas has varied: it was first struck on the footing of 20s.; by the scarcity of gold was afterwards advanced to 21s. 6d. but it is now sunk to 21s.

The pound weight troy of gold is cut into 44 parts

5

and a half; each part makes a guinea. This coin took its denomination *guinea*, because the gold, of which the first was struck, was brought from that part of Africa called *Guinea*; for this reason it likewise bore the impression of an elephant.

GUINEA-Company. See COMPANY, *African*.

GUINEA-Hen. See NUMIDA, ORNITHOLOGY *Index*.

GUINEA-Pig. See MUS, MAMMALIA *Index*.

GUINEA-Wheat. See ZEA, BOTANY *Index*.

GUIPUSCOA, the north-east division of the province of Biscay in Spain, abounding with wood, fruit-trees, and containing numerous forges for the manufacture of iron.

GUISE, a small town of France, in the department of Aisne, and in Tierache, with a very strong castle, and the title of a duchy. It is seated on the river Oise, in E. Long. 3. 42. N. Lat. 49. 54.

GUISE, *Henry*, of Lorraine, duke of Guise, eldest son of François of Lorraine duke of Guise, memorable in the history of France as a gallant officer; but an imperious, turbulent, seditious subject, who placed himself at the head of an armed force, and called his rebel band *The League*. The plan was formed by the cardinal, his younger brother; and under the pretext of defending the Roman Catholic religion, the king Henry III. and the freedom of the state, against the design of the Huguenots, or French Protestants, they carried on a civil war, massacred the Huguenots, and governed the king, who forbid his appearance at Paris; but Guise now became an open rebel, entered the city against the king's express order, and put to the sword all who opposed him; the streets being barricaded to prevent his progress, this fatal day is called in the French history, *The day of the barricades*. Masters of Paris, the policy of the Guises failed them: for they suffered the king to escape to Blois, though he was deserted in his palace at Paris by his very guards. At Blois, Henry convened an assembly of the states of France; the duke of Guise had the boldness to appear to a summons sent him for that purpose: a forced reconciliation took place between him and the king, by the advice of this assembly; but it being accidentally discovered, that Guise had formed a design to dethrone the king, that weak monarch, instead of resolutely bringing him to justice, had him privately assassinated, December 23. 1558, in the 38th year of his age. His brother the cardinal shared the same fate the next day.

GIUITAR, GUITARRA, a musical instrument of the stringed kind, with five double rows of strings; of which those that are brass are in the middle, except it be for the burden, an octave lower than the fourth.

—This instrument was first used in Spain and by the Italians. In the former country it is still greatly in vogue. There are few of that nation who cannot play on the guittar; and with this instrument they serenade their mistresses at night. At Madrid, and other cities in that country, it is common to meet in the streets young men equipped with a guittar and a dark lantern, who, taking their station under the windows, sing, and accompany their voices with this instrument; and there is scarce an artificer or day-labourer in any of the cities or principal towns who does not entertain himself with his guittar.

GULDENSTAEDT, JOHN ANTHONY, physician and

Guinea
&
Gulden-
staedt.

Gulden-
staedt.Gula
Gum.

and naturalist, was born at Riga, April 26. 1745; received the rudiments of his education in that town; and in 1763 was admitted into the medical college of Berlin. He completed his studies at Frankfort upon the Oder, and in 1767 received the degree of M. D. in that university. On account of his knowledge of foreign languages, and the considerable progress he had made in natural history, he was considered as a fit person to engage in the expeditions which were planned by the Imperial academy. Being invited to St Petersburg, he arrived in that city in 1768, was created adjunct of the academy, and afterwards, in 1770, member of that society, and professor of natural history. In June 1768 he set out upon his travels, and was absent seven years. From Moscow, where he continued till March 1769, he passed to Voronetz, Tzaritzin, Astracan, and Kislar, a fortress upon the western shore of the Caspian, and close to the confines of Persia. In 1770 he examined the districts watered by the rivers Terek, Sunsha, and Alksai, in the eastern extremity of Caucasus; and in the course of the ensuing year penetrated into Ossetia, in the highest part of the same mountain; where he collected vocabularies of the languages spoken in those regions, made inquiries into the history of the people, and discovered some traces of Christianity among them. Having visited Cabarda and the northern chain of the Caucasus, he proceeded to Georgia, and was admitted to an audience of Prince Heraclius, who was encamped about ten miles from Teflis. Having passed the winter here, and in examining the adjacent country, he followed in spring the prince to the province of Kaketia, and explored the southern districts inhabited by the Turcoman Tartars in the company of a Georgian magnate, whom he had cured of a dangerous disorder. In July he passed into Imeretia, a country which lies between the Caspian and Black seas, and is bounded on the east by Georgia, on the north by Ossetia, on the west by Mingrelia, and on the south by the Turkish dominions. He penetrated into the middle chain of Mount Caucasus, visited the confines of Mingrelia, Middle Georgia, and Eastern and Lower Imeretia; and, after escaping many imminent dangers from the banditti of those parts, fortunately returned to Kislar on the 18th of November, where he passed the winter, collecting various information concerning the neighbouring Tartar tribes of the Caucasus, and particularly the Lesgees. In the following summer he journeyed to Cabarda Major, continued his course to Mount Beshton, the highest point of the first ridge of the Caucasus; inspected the mines of Madshar, and went to Tcherkask upon the Don. From thence he made expeditions to Azof and Taganrog, and then, along the new limits to the Dnieper. He finished this year's route at Krementshuk, in the government of New Russia. In the ensuing spring he was proceeding to Criss Tartary; but receiving an order of recall, he returned through the Ukraine to Moscow and St Petersburg, where he arrived in the month of March 1775. Upon his return, he was employed in arranging his papers; but before he could finish them for the press, was seized with a violent fever, which carried him to the grave in March 1781. His writings which have been hitherto published consist of a number of curious treatises, of which a list is given in Coxe's Travels, vol. i. p. 162.

VOL. X. Part I.

+

GULA, in *Anatomy*, the oesophagus or gullet; that conduit by which animals take down food into the stomach. See ANATOMY, N^o 92.

GULE of AUGUST, the day of St Peter *ad vincula*, which is celebrated on the first of August. It is called the *gule of August*, from the Latin *gula*, "a throat," for this reason, that one Quirinus, a tribune, having a daughter that had a disease in her throat, went to Pope Alexander, the sixth from St Peter, and desired of him to see the chains that St Peter was chained with under Nero; which request being granted, and she, kissing the chains, was cured of her disease; whereupon the Pope instituted this feast in honour of St Peter; and, as before, this day was termed only the kalends of August, it was on this occasion called indifferently either the day of St Peter *ad vincula*, from what wrought the miracle; or the *gule of August*, from that part of the virgin whereon it was wrought.

GULES, in *Heraldry*, a corruption of the French word *geules*, which in this science signifies "red," and is represented in engraving by perpendicular lines. It may serve of itself to denote martial prowess, boldness, and hardiness: for the ancients used this colour to make themselves terrible to their enemies, to stir up magnanimity, and to prevent the seeing of blood, by the likeness of the colours; for which reason perhaps it is used by the English. But, according to G. Leigh, if this tincture is compounded with

Or.	} it signifies	{	Desire.
Arg.			Envy.
Azu.			Ardour.
Ver.			Strength.
Pur.			Justice.
Sab.			Weariness.

This colour is by the generality of the English heralds ranked before azure; but French heralds, N. Upton and his followers, prefer azure to it.

GULF, a broad and capacious bay comprehended between two promontories, and sometimes taking the name of a *sea* when it is very extensive; but particularly when it only communicates with the sea by means of a strait. Such are the Euxine or Black sea, otherwise called the *Gulf of Constantinople*; the Adriatic sea, called also the *Gulf of Venice*; the gulf of Sidra near Barbary; and the gulf of Lyons near France. All these gulfs are in the Mediterranean. There are, besides, the gulf of Mexico, the gulf of St Lawrence, and the gulf of California, which are in North America. There are also the gulf of Persia, otherwise called the *Red sea*, between Persia and Arabia; the gulf of Bengal in India; and the gulfs of Cochinchina and Kantschatka, near the countries of the same name.

The word comes from the French *golfe*, and that from the Italian *golfo*, which signify the same. Some deduce these further from the Greek *γολφος*; which Guishart again derives from the Hebrew *גולב* *gob*. Du Cange derives them from the barbarous Latin *gulfum*, or *gulfus*, which signifies the same thing.

GULL. See LARUS, ORNITHOLOGY *Index*.

GULLET. See GULA, ANATOMY, N^o 92.

GUM (*Gummi*), is a concrete vegetable juice, of no particular smell or taste, becoming viscous and tenacious

T

Gum
Gums.

cious when moistened with water; totally dissolving in water into a liquid, more or less glutinous in proportion to the quantity of the gum; not dissolving in vinous spirits or in oils; burning in the fire to a black coal, without melting or catching flame; suffering no dissipation in the heat of boiling water.

The true gums are gum arabic, gum tragacanth, gum senegal, the gum of cherry and plum trees, and such like. All else have more or less of resin in them.

GUM Arabic is the produce of a species of *MIMOSA*; which see in *CHEMISTRY* and *MATERIA MEDICA Index*.

GUM Senegal, is a gum resembling gum arabic, which is brought from the country through which the river Senegal runs, in loose or single drops: but these are much larger than those of the gum arabic usually are; sometimes it is of the bigness of an egg, and sometimes much larger: the surface is very rough or wrinkled, and appears much less bright than the inner substance where the masses are broken. It has no smell, and scarce any taste. It is probably produced from a tree of the same kind with the former. The virtues of it are the same with the gum arabic; but it is rarely used in medicine, unless as mixed with the gum arabic; the dyers and calico printers consume the great quantities of it that are annually imported. The negroes dissolve it in milk, and in that state make it a principal ingredient in many of their dishes, and often feed on it thus alone.

GUM Tragacanth, the gum of the tragacanth, a thorny bush growing in Crete, Asia, and Greece. See *ASTRAGALUS*, *BOPANY Index*.

Other substances known by the name of *gums* are as follows:

GUM Ammoniac. See *AMMONIAC*.

GUM Elemi. See *AMYRIS*.

GUM Kino. See *KINO*.

GUM Guaiacum. See *GUAIACUM*.

GUM Lacca. See *COCCUS* and *LACCA*.

See *CHEMISTRY*
and *MATERIA*
MEDICA Index.

GUM, among gardeners, a kind of gangrene incident to fruit trees of the stone kind, arising from a corruption of the sap; which, by its viscosity, not being able to make its way through the fibres of the tree, is, by the protrusion of other juice, made to extravasate and ooze out upon the bark.

When the distemper surrounds the branch, it admits of no remedy; but when only on one part of a bough, it should be taken off to the quick, and some coagulum clapped on the wound, covered over with a linen cloth, and tied down. M. Quintinie directs to cut off the morbid branch two or three inches below the part affected.

GUMMA, a sort of venereal excrescence on the periosteum of the bones.

GUMS, in *Anatomy*, the hard fleshy substance in either jaw, through which the teeth spring from the jaw-bone. See *ANATOMY*, N^o 105.

The gums are apt to become spongy, and to separate from the teeth; but the cause is frequently a stony kind of crust, which forms itself therein, which, when separated, the gums soon return to their former state; especially if rubbed with a mixture of the infusion of roses four parts, and the tincture of myrrh one part.—

The *scurvy* is another disorder which affects the gums.

Gums,
Gun.

This disorder, when not manifest in any other part, sometimes appears in this: indeed, when a scorbutic disorder invades the whole habit, its first symptom is a putrid state of the gums.

GUN, in the military art, a fire-arm, or weapon of offence, which forcibly discharges a ball or other hard and solid matter through a cylindrical tube, by means of inflamed gun-powder. See *GUN-POWDER*.

The word gun now includes most of the species of fire-arms; pistols and mortars being almost the only ones excepted from this denomination. They are divided into great and small guns: the former including all that we also call cannon, ordnance or artillery; the latter includes musquets, carbines, musquetoons, blunderbusses, fowling-pieces, &c.

It is not known at what time these weapons were first invented. Though, comparatively speaking, the introduction of guns into the western part of the world is but of a modern date; yet it is certain that in some parts of Asia they have been used, though in a very rude and imperfect manner for many ages.—Philostratus speaks of a city near the river Hyphasis in the Indies, which was said to be impregnable, and that its inhabitants were relations of the gods, because they threw thunder and lightning upon their enemies. Hence some imagine that guns were used by the eastern nations even in the time of Alexander the Great: but however this may be, many of our modern travellers assert that they were used in China as far back as the year of Christ 85, and have continued in use ever since.

The first hint of the invention of guns in Europe is in the works of Roger Bacon, who flourished in the 13th century. In a treatise written by him about the year 1280, he proposes to apply the violent explosive force of gun-powder for the destruction of armies. In 1320, Bartholomew Schwartz, a German monk, is commonly said to have invented gun-powder, though it is certainly known that this composition is described by Bacon in some of his treatises long before the time of Schwartz. The following is said to have been the manner in which Schwartz invented gun-powder. Having pounded the materials for it in a mortar, which he afterwards covered with a stone, a spark of fire accidentally fell into the mortar and set the mixture on fire; upon which the explosion blew the stone to a considerable distance. Hence it is probable that Schwartz might be taught the simplest method of applying it in war; for Bacon seems rather to have conceived the manner of using it to be by the violent effort of the flame unconfined, and which is indeed capable of producing astonishing effects*. The figure and name of * See Gun- mortars given to a species of old artillery, and their powder.

Soon after the time of Schwartz, we find guns commonly made use of as instruments of war. Great guns were first used. They were originally made of iron bars soldered together, and fortified with strong iron hoops; some of which are still to be seen, viz. one in the Tower of London, two at Woolwich, and one in the royal arsenal at Lisbon. Others were made of thin sheets of iron rolled up together and hooped; and on emergencies they were made of leather, with plates of iron or copper. These pieces were made in a rude and imperfect manner, like the first essays of many new inventions.

Gun. inventions. Stone balls were thrown out of them, and a small quantity of powder used on account of their weakness. These pieces had no ornaments, were placed on their carriages by rings, and were of a cylindrical form. When or by whom they were made is uncertain: the Venetians, however, used cannon at the siege of Claudia Jessa, now called *Chioggia*, in 1366, which were brought thither by two Germans, with some powder and leaden balls; as likewise in their wars with the Genoese in 1379. King Edward III. made use of cannon at the battle of Cressy in 1346, and at the siege of Calais in 1347. Cannon were made use of by the Turks at the siege of Constantinople, then in possession of the Christians, in 1394, and in that of 1452, that threw a weight of 100lb. but they generally burst either the first, second, or third shot. Louis XII. had one cast at Tours, of the same size, which threw a ball from the Bastille to Charenton. One of those famous cannon was taken at the siege of Dieu in 1546, by Don John de Castro; and is in the castle of St Juliao da Barra, 10 miles from Lisbon: its length is 20 feet 7 inches, diameter at the centre 6 feet 3 inches, and it discharges a ball of 100lb. It has neither dolphins, rings, nor button; is of a curious kind of metal; and has a large Indostan inscription upon it, which says it was cast in 1400.

Formerly the cannon were dignified with uncommon names; for in 1503, Louis XII. had 12 brass cannon cast, of an extraordinary size, called after the names of the 12 peers of France. The Spanish and Portuguese called them after their saints. The emperor Charles V. when he marched before Tunis, founded the 12 apostles. At Milan there is a 70 pounder, called the *Pimontelle*; and one at Bois-le-duc, called the *Devil*. A 60 pounder at Dover-castle, called *Queen Elizabeth's pocket-pistol*. An 80 pounder in the Tower of London (formerly in Edinburgh-castle), called *Mounts-meg*. An 80 pounder in the royal arsenal at Berlin, called the *Thunderer*. An 80 pounder at Malaga, called the *Terrible*. Two curious 60 pounders in the arsenal at Bremen, called the *Messengers of bad news*. And, lastly, an uncommon 70 pounder in the castle of St Angelo at Rome, made of the nails that fastened the copper plates which covered the ancient Pantheon, with this inscription upon it: *Ex clavis trabalibus porticus Agrippæ*.

In the beginning of the 15th century these uncommon names were generally abolished, and the following more universal ones took place, viz.

	Pounders.	Cwt.
Cannon royal, or carthoun	} = 48	about 90
Bastard cannon, or $\frac{1}{2}$ carthoun	} = 36	79
$\frac{1}{3}$ Carthoun	= 24	60
Whole culverins	= 18	50
Demi culverins	= 9	30
Falcon	= 6	25
Sacker { lowest sort	= 5	13
{ ordinary	= 6	15
{ largest size	= 8	18
Basilisk	= 48	85
Serpentine	= 4	8
Aspic	= 2	7

	Pounders.	Cwt.
Dragon	= 6	12
Syren	= 60	81
Falconet	= 3, 2, & 1	15, 10, 5
Moyens, which carried a ball of 10 or 12 ounces.		
Rabinet, which carried a ball of 16 ounces.		

These curious names of beasts and birds of prey were adopted on account of their swiftness in motion or of their cruelty; as the falconet, falcon, sacker, and culverin, &c. for their swiftness in flying; the basilisk, serpentine, aspic, dragon, syren, &c. for their cruelty.

At present cannon take their names from the weight of the ball they discharge. Thus a piece that discharges a ball of 24 pounds is called a *24 pounder*; one that carries a ball of 12 pounds is called a *12 pounder*; and so of the rest, divided into the following sorts, viz.

Ship guns, consisting in 42, 36, 32, 24, 18, 12, 9, 6, and 3 pounders.

Garrison guns, in 42, 32, 24, 18, 12, 9, and 6 pounders,

Battering guns, in 24, 18, and 12 pounders.

Field-pieces, in 12, 9, 6, 3, 2, $1\frac{1}{2}$, 1, and $\frac{1}{2}$ pounders.

Mortars are thought to have been fully as ancient as cannon. They were employed in the wars of Italy, to throw balls of red-hot iron, stones, &c. long before the invention of shells. These last are thought to be of German invention, and the use of them in war to have been taught by the following accident. A citizen of Venlo, at a certain festival celebrated in honour of the duke of Cleves, threw a number of shells, one of which fell on a house and set fire to it, by which misfortune the greatest part of the town was reduced to ashes. The first account of shells used for military purposes is in 1435, when Naples was besieged by Charles VIII. History informs us with more certainty, that shells were thrown out of mortars at the siege of Wachtendonk in Guelderland, in 1588, by the earl of Mansfeld. Mr Malter, an English engineer, first taught the French the art of throwing shells, which they practised at the siege of Motte in 1634. The method of throwing red-hot balls out of mortars was first certainly put in practice at the siege of Stralsund in 1675 by the elector of Brandenburg; though some say in 1653 at the siege of Bremen. For the proper dimensions of guns, their weight, the metal of which they are formed, &c. see the article GUNNERY.

Muskets were first used at the siege of Rhege in the year 1521. The Spaniards were the first who armed part of their foot with these weapons. At first they were very heavy, and could not be used without a rest. They had match-locks, and did execution at a great distance. On their march the soldiers carried only the rests and ammunition, and had boys to bear their muskets after them. They were very slow in loading, not only by reason of the unwieldiness of their pieces, and because they carried the powder and ball separate, but from the time it took to prepare and adjust the match; so that their fire was not near so brisk as ours is now. Afterwards a lighter matchlock-musket came in use; and they carried their ammunition in bandeliers, to which were hung several little cases of

Gun
Gunner.

wood covered with leather, each containing a charge of powder. The balls were carried loose in a pouch, and a priming-born hanging by their side. The muskets with rests were used as late as the beginning of the civil wars in the time of Charles I. The lighter kind succeeded them, and continued till the beginning of the present century, when they also were disused, and the troops throughout Europe armed with firelocks.

GUNDELIA, a genus of plants belonging to the syngenesia class; and in the natural method ranking under the 49th order, *Compositæ*. See *BOTANY Index*.

GUNELLUS. See **BLENNIUS**, *ICHTHYOLOGY Index*.

GUNNER, an officer appointed for the service of the cannon, or one skilled to fire the guns.

Ganner,
Gannera.

In the Tower of London, and other garrisons, as well as in the field, this officer carries a field-staff, and a large powder-horn in a string over his left shoulder: he marches by the guns; and when there is any apprehension of danger, his field-staff is armed with match. His business is to lay the gun to pass, and to help to load and traverse her.

Master GUNNER, a patent-officer of the ordnance, who is appointed to teach all such as learn the art of gunnery, and to certify to the master-general the ability of any person recommended to be one of the king's gunners. To every scholar he administers an oath not to serve, without leave, any other prince or state; or teach any one the art of gunnery but such as have taken the said oath.

GUNNERA, a genus of plants belonging to the gynandria class. See *BOTANY Index*.

G U N N E R Y,

IS the art of charging, directing, and exploding fire-arms, as cannons, mortars, muskets, &c. to the best advantage.—As this art depends greatly on having the guns and shot of a proper size and figure, and well adapted to each other, it hence follows that the proper dimensions, &c. of cannon and small arms come properly to be considered under the present article.

SECT. I. *History of Gunnery.*

History.

THE ancients, who knew not the use of gunpowder and fire-arms, had notwithstanding machines which were capable of discharging stones, darts, and arrows, with great force. These were actuated chiefly by the elastic force of ropes, or of strong springs, and required a great number of men to work them; for which reason, the explosion of gunpowder, as acting instantaneously, and seemingly with irresistible force, seemed to be a most proper succedaneum for all the powers by which the military engines in former times were actuated. It soon appeared, however, that this force was not very easily applied. Though the experiment of Bartholomew Schwartz, mentioned under the article **GUN**, had given a good hint towards this application in a successful manner, yet the violent reaction of the inflamed powder on the containing vessels rendered them very apt to burst, to the great danger of those who stood near them. The gunpowder in those days, therefore, was much weaker than it is now made; though this proved a very insufficient remedy for the inconvenience above mentioned. It was also soon discovered, that iron bullets of much less weight than stone ones would be more efficacious if impelled by greater quantities of stronger powder. This occasioned an alteration in the matter and form of the cannon, which were now cast of brass. These were lighter and more manageable than the former, at the same time that they were stronger in proportion to their bore. Thus they were capable of enduring greater charges of a better powder than what had been formerly used; and their iron bullets (which were from 40 to 60 pounds weight) being impelled with greater velocities,

were more effectual than the heaviest stones could ever prove. This change took place about the latter end of the 15th century.

By this means powder compounded in the manner now practised over all Europe came first in use. But the change of the proportion of materials was not the only improvement it received. The method of grain-ing it is undoubtedly a considerable advantage. At first the powder was always in the form of fine meal, such as it was reduced to by grinding the materials together. It is doubtful whether the first grain-ing of powder was intended to increase its strength, or only to render it more convenient for filling into small charges and the charging of small arms, to which alone it was applied for many years, whilst meal-powder was still made use of for cannon. But at last the additional strength which the grained powder was found to acquire from the free passage of the air between the grains, occasioned the meal-powder to be entirely laid aside.

For the last two hundred years, the formation of cannon hath been very little improved; the best pieces of modern artillery differing little in their proportions from those used in the time of Charles V. Indeed lighter and shorter pieces have been often proposed and essayed; but though they have their advantages in particular cases, yet it seems now to be agreed that they are altogether insufficient for general service. But though the proportions of the pieces have not been much varied within that period, yet their use and application have undergone considerable alterations; the same ends being now accomplished by smaller pieces than what were formerly thought necessary. Thus the battering cannon now universally approved of are those formerly called *demi-cannons*, carrying a ball of 24 pounds weight; it being found by experience, that their stroke, though less violent than that of larger pieces, is yet sufficiently adapted to the strength of the usual profiles of fortification; and that the facility of their carriage and management, and the ammunition they spare, give them great advantages beyond the whole cannons formerly employed in making

Theory. king breaches. The method also of making a breach, by first cutting off the whole wall as low as possible before its upper part is attempted to be beat down, seems also to be a considerable modern improvement in the practical part of gunnery. But the most considerable improvement in the practice is the method of firing with small quantities of powder, and elevating the piece so that the bullet may just go clear of the parapet of the enemy, and drop into their works. By this means the bullet, coming to the ground at a small angle, and with a small velocity, does not bury itself, but bounds or rolls along in the direction in which it was fired: and therefore, if the piece be placed in a line with the battery it is intended to silence, or the front it is to sweep, each shot rakes the whole length of that battery or front; and has thereby a much greater chance of disabling the defendants, and dismounting their cannon, than it would have, if fired in the common manner. This method was invented by Vauban, and was by him styled *Batterie à Ricochet*. It was first put in practice in the year 1692 at the siege of Aeth.—Something similar to this was put in practice by the king of Prussia at the battle of Rosbach in 1757. He had several six-inch mortars, made with trunnions and mounted on travelling carriages, which fired obliquely on the enemy's lines, and amongst their horse. They were charged with eight ounces of powder, and elevated at an angle of one degree fifteen minutes, and did great execution; for the shells rolling along the line with burning fuses made the stoutest of the enemy not wait for their bursting.

SECT. II. *Theory of Gunnery.*

Theory of gunnery, first attempted by Tartalea. THE use of fire-arms had been known for a long time before any theory concerning them was attempted. The first author who wrote professedly on the flight of cannon-shot was Tartalea. In 1537 he published a book, at Venice, entitled *Nova Scientia*; and afterwards another, entitled *Quasiti et Inventioni diversi*, printed at the same place in 1546, in which he treats professedly on these motions. His discoveries were but few, on account of the imperfect state of mechanical knowledge at that time. However, he determined, that the greatest range of cannon was with an elevation of 45 degrees. He likewise determined, (contrary to the opinion of practitioners), that no part of the track described by a bullet was a right line; although the curvature was in some cases so little, that it was not attended to. He compared it to the surface of the sea; which, though it appears to be a plane, is yet undoubtedly incurvated round the centre of the earth. He also assumes to himself the invention of the gunner's quadrant, and often gave shrewd guesses at the event of some untried methods. But as he had not opportunities of being conversant in the practice, and founded his opinions only on speculation, he was condemned by most of the succeeding writers, though often without any sufficient reason. The philosophers of those times also intermeddled in the questions hence arising; and many disputes on motion were set on foot (especially in Italy,) which continued till the time of Galileo, and probably gave rise to his celebrated Dialogues on motion. These were published in the year 1638; but in this interval, and before Galileo's doc-

Theory. trine was thoroughly established, many theories of the motion of military projectiles, and many tables of their comparative ranges at different elevations, were published; all of them egregiously fallacious, and utterly irreconcilable with the motions of these bodies. Very few of the ancients indeed refrained from indulging themselves in speculations concerning the difference betwixt natural, violent, and mixed motions; although scarce any two of them could agree in their theories.

It is strange, however, that, during all these ³Experiments, so few of those who were intrusted with the charge of artillery thought it worth while to bring different persons on the ranges of artillery. Mr Robins informs us, in his Preface to the *New Principles of Gunnery*, that he had met with no more than four authors who had treated on this subject. The first of these is Collado, who has given the ranges of a falconet carrying a three-pound shot to each point of the gunner's quadrant. But from his numbers it is manifest, that the piece was not charged with its customary allotment of gunpowder. The results of his trials were, that the point-blank shot, or that in which the path of the ball did not sensibly deviate from a right line, extended 268 paces. At an elevation of one point (or $7\frac{1}{2}^{\circ}$ of the gunner's quadrant) the range was 594 paces; at an elevation of two points, 794 paces; at three points, 954 paces; at four, 1010; at five, 1040; and at six, 1053 paces. At the seventh point, the range fell between those of the third and fourth; at the eighth point, it fell between the ranges of the second and third; at the ninth point, it fell between the ranges of the first and second; at the tenth point, it fell between the point-blank distance and that of the first point; and at the eleventh point, it fell very near the piece.—The paces spoke of by this author are not geometrical ones, but common steps.

The year after Collado's treatise, another appeared on the same subject by one Bourne an Englishman. His elevations were not regulated by the points of the gunner's quadrant, but by degrees: and he ascertains the proportions between the ranges at different elevations and the extent of point-blank shot. According to him, if the extent of the point-blank shot be represented by 1, the range at 5° elevation will be $2\frac{2}{3}$, at 10° it will be $3\frac{1}{3}$, at 15° it will be $4\frac{1}{3}$, at 20° it will be $4\frac{2}{3}$, and the greatest random will be $5\frac{1}{3}$. This last, he tells us, is in a calm day when the piece is elevated to 42° ; but according to the strength of the wind, and as it favours or opposes the flight of the shot, it may be from 45° to 36° .—He hath not informed us with what piece he made his trials; though by his proportions it seems to have been a small one. This however ought to have been attended to, as the relation between the extent of different ranges varies extremely according to the velocity and density of the bullet.

After him Eldred and Anderson, both Englishmen, published treatises on this subject. The first published his treatise in 1646, and has given the actual ranges of different pieces of artillery at small elevations, all under ten degrees. His principles were not rigorously true, though not liable to very considerable errors; yet, in consequence of their deviation from the truth,

he

Theory.

he found it impossible to make some of his experiments agree with his principles.

Galileo's theory.

In 1639, Galileo printed his dialogues on motion. In these he pointed out the general laws observed by nature in the production and composition of motion; and was the first who described the action and effects of gravity on falling bodies. On these principles he determined, that the flight of a cannon shot, or any other projectile, would be in the curve of a parabola, except in as far as it was diverted from that track by the resistance of the air. He has also proposed the means of examining the inequalities which arise from thence, and of discovering what sensible effects that resistance would produce in the motion of a bullet at some given distance from the piece.

Though Galileo had thus shown, that, independent of the resistance of the air, all projectiles would, in their flight, describe the curve of a parabola; yet those who came after him, seem never to have imagined that it was necessary to consider how far the operations of gunnery were affected by this resistance. The subsequent writers indeed boldly asserted, without making the experiment, that no considerable variation could arise from the resistance of the air in the flight of shells or cannon shot. In this persuasion they supported themselves chiefly by considering the extreme rarity of the air, compared with those dense and ponderous bodies: and at last it became an almost generally established maxim, that the flight of these bodies was nearly in the curve of a parabola.

New theory by Anderson.

In 1674, Mr Anderson above mentioned published his treatise on the nature and effects of the gun; in which he proceeds on the principles of Galileo, and strenuously asserts, that the flight of all bullets is in the curve of a parabola; undertaking to answer all objections that could be brought to the contrary. The same thing was also undertaken by Mr Blondel, in a treatise published at Paris in 1683; where, after long discussion, the author concludes, that the variations from the air's resistance are so slight as scarce to merit notice. The same subject is treated of in the *Philosophical Transactions*, N^o 216. p. 68. by Dr Halley; and he also, swayed by the very great disproportion between the density of the air and that of iron or lead, thinks it reasonable to believe, that the opposition of the air to large metal-shot is scarcely discernible; although in small and light shot he owns that it must be accounted for.

But though this hypothesis went on smoothly in speculation; yet Anderson, who made a great number of trials, found it impossible to support it without some new modification. For though it does not appear that he ever examined the comparative ranges of either cannon or musket shot when fired with their usual velocities, yet his experiments on the ranges of shells thrown with small velocities (in comparison of those above mentioned), convinced him that their whole track was not parabolical. But instead of making the proper inferences from hence, and concluding the resistance of the air to be of considerable efficacy, he framed a new hypothesis; which was, that the shell or bullet, at its first discharge, flew to a certain distance in a right line, from the end of which line only it began to describe a parabola. And this right line, which he calls the *line of the impulse of the fire*, he

supposes to be the same in all elevations. Thus, by assigning a proper length to this line of impulse, it was always in his power to reconcile any two shots made at different angles, let them differ as widely as we please to suppose. But this he could not have done with three shots; nor indeed doth he ever tell us the event of his experiments when three ranges were tried at one time.

When Sir Isaac Newton's *Principia* was published, he particularly considered the resistance of the air to projectiles which moved with small velocities; but as he never had an opportunity of making experiments on those which move with such prodigious swiftness, he did not imagine that a difference in velocity could make such differences in the resistance as are now found to take place. Sir Isaac found, that, in small velocities, the resistance was increased in the duplicate proportion of the swiftness with which the body moved; that is, a body moving with twice the velocity of another of equal magnitude, would meet with four times as much resistance as the first, with thrice the velocity it would meet with nine times the resistance, &c.—This principle itself is now found to be erroneous with regard to military projectiles; though, if it had been properly

attended to, the resistance of the air might even from thence have been reckoned much more considerable than was commonly done. So far, however, were those who treated this subject scientifically, from giving a proper allowance for the resistance of the atmosphere, that their theories differed most egregiously from the truth. Huygens alone seems to have attended to this principle: for, in the year 1690, he published a *Treatise on Gravity*, in which he gave an account of some experiments tending to prove, that the track of all projectiles moving with very swift motions was widely different from that of a parabola. All the rest of the learned acquiesced in the justness of Galileo's doctrine, and very erroneous calculations concerning the ranges of cannon were accordingly given. Nor was any notice taken of these errors till the year 1716.

At that time M. Reaumur, a French officer of artillery, distinguished by the number of sieges at which he had served, by his high military rank, and by his abilities in his profession, gave in a memoir to the Royal Academy, of which he was a member, importing, that, "although it was agreed, that theory joined with practice did constitute the perfection of every art; yet experience had taught him, that theory was of very little service in the use of mortars: That the works of M. Blondel had justly enough described the several parabolic lines, according to the different degrees of the elevation of the piece; but that practice had convinced him, there was no theory in the effect of gunpowder; for having endeavoured, with the greatest precision, to point a mortar agreeably to these calculations, he had never been able to establish any solid foundation upon them."

From the history of the academy, it doth not appear that the sentiments of M. Reaumur were at any time controverted, or any reason offered for the failure of the theory of projectiles when applied to use. Nothing farther, however, was done till the time of Benjamin Robins, who in 1742 published a treatise, entitled, *New Principles of Gunnery*, in which he hath treated particularly not only of the resistance of the atmosphere,

Theory.

Laws of the air's resistance laid down by Newton.

Erroneous in military projectiles.

All these theories widely different from the truth.

Mr Robins first introduces a true theory.

Theory. atmosphere, but almost every thing else relating to the flight of military projectiles, and indeed advanced the theory of gunnery much nearer perfection than ever it was before.

10
His method of determining the force of gunpowder.

The first thing considered by Mr Robins, and which is indeed the foundation of all other particulars relative to gunnery, is the explosive force of gunpowder. This he determined to be owing to an elastic fluid similar to our atmosphere, having its elastic force greatly increased by the heat. "If a red-hot iron (says he) be included in a receiver, and the receiver be exhausted, and gunpowder be then let fall on the iron, the powder will take fire, and the mercurial gage will suddenly descend upon the explosion; and though it immediately ascends again, it will never rise to the height it first stood at, but will continue depressed by a space proportioned to the quantity of powder which was let fall on the iron. The same production likewise takes place when gunpowder is fired in the air: for if a small quantity of powder is placed in the upper part of a glass tube, the lower part of which is immersed in water, and the fluid be made to rise so near the top, that only a small portion of air is left in that part where the gunpowder is placed; if in this situation the communication of the upper part of the tube with the external air is closed, and the gunpowder fired; which may be easily done by means of a burning-glass, the water will in this experiment descend on the explosion, as the quicksilver did in the last; and will always continue depressed below the place at which it stood before the explosion. The quantity of this depression will be greater if the quantity of powder be increased, or the diameter of the tube be diminished.

"When any considerable quantity of gunpowder is fired in an exhausted receiver, by being let fall on a red-hot iron, the mercurial gage instantly descends upon the explosion, and as suddenly ascends again. After a few vibrations, none of which except the first are of any great extent, it seemingly fixes at a point lower than where it stood before the explosion. But even when the gage has acquired this point of apparent rest, it still continues rising for a considerable time, although by such imperceptible degrees, that it can only be discovered by comparing its place at distant intervals: however, it will not always continue to ascend; but will rise slower and slower, till at last it will be absolutely fixed at a point lower than where the mercury stood before the explosion. The same circumstances nearly happen, when powder is fired in the upper part of an unexhausted tube, whose lower part is immersed in water.

"That the elasticity or pressure of the fluid produced by the firing of gunpowder is, *ceteris paribus*, directly as its density, may be proved from hence, that if in the same receiver a double quantity of powder be let fall, the mercury will subside twice as much as in the firing of a single quantity. Also the descents of the mercury, when equal quantities of powder are fired in different receivers, are reciprocally as the capacities of those receivers, and consequently as the density of produced fluid in each. But as, in the usual method of trying this experiment, the quantities of powder are so very small that it is difficult to ascertain these proportions with the requisite degree of exactness, I took a large receiver, containing about 500 inches, and let-

ting fall at once on the red-hot iron one dram, or the sixteenth part of an ounce avoirdupois of powder, the receiver being first nearly exhausted; the mercury, after the explosion, was subsided two inches exactly, and all the powder had taken fire. Then heating the iron a second time, and exhausting the receiver as before, two drams were let down at once, which sunk the mercury three inches and three quarters; and a small part of the powder had fallen beside the iron, which (the bottom of the receiver being wet) did not fire, and the quantity which thus escaped did appear to be nearly sufficient, had it fallen on the iron, to have sunk the mercury a quarter of an inch more; in which case the two descents, viz. two inches and four inches, would have been accurately in the proportion of the respective quantities of powder; from which proportion, as it was, they very little varied.

"As different kinds of gunpowder produce different quantities of this fluid, in proportion to their different degrees of goodness, before any definite determination of this kind can take place, it is necessary to ascertain the particular species of powder that is proposed to be used. (Here Mr Robins determines in all his experiments to make use of government powder, as consisting of a certain and invariable proportion of materials, and therefore preferable to such kinds as are made according to the fancy of private persons).

"This being settled, we must farther premise these two principles: 1. That the elasticity of this fluid increases by heat and diminishes by cold, in the same manner as that of the air: 2. That the density of this fluid, and consequently its weight, is the same with the weight of an equal bulk of air, having the same elasticity and the same temperature. Now from the last experiment it appears, that $\frac{1}{16}$ of an ounce avoirdupois, or about 27 grains troy of powder, sunk the gage, on its explosion, two inches; and the mercury in the barometer standing at near 30 inches, $\frac{1}{16}$ ths of an ounce avoirdupois, or 410 grains troy, would have filled the receiver with a fluid whose elasticity would have been equal to the whole pressure of the atmosphere, or the same with the elasticity of the air we breathe; and the contents of the receiver being about 520 cubic inches, it follows, that $\frac{1}{16}$ ths of an ounce of powder will produce 520 cubic inches of a fluid possessing the same degree of elasticity with the common air; whence an ounce of powder will produce near 575 cubic inches of such a fluid.

"But in order to ascertain the density of this fluid, we must consider what part of its elasticity, at the time of this determination, was owing to the heat it received from the included hot iron and the warm receiver. Now the general heat of the receiver being manifestly less than that of boiling water, which is known to increase the elasticity of the air to somewhat more than $\frac{1}{7}$ of its augmented quantity; I collect from hence and other circumstances, that the augmentation of elasticity from this cause was about $\frac{1}{7}$ of the whole: that is, if the fluid arising from the explosion had been reduced to the temperature of the external air, the descent of the mercurial gage, instead of two inches, would have been only $1\frac{1}{7}$ inch; whence 575, reduced in the proportion of five to four, becomes 460; and this last number represents the cubic inches of an elastic fluid equal in density and elasticity with common air, which are produ-

Theory.

Theory.

ced from the explosion of 1 ounce avoirdupois of gunpowder; the weight of which quantity of fluid, according to the usual estimation of the weight of air, is 131 grains; whence the weight of this fluid is $\frac{1}{2} \frac{1}{3} \frac{1}{4}$ or $\frac{1}{2}$ the nearly of the weight of the generating powder. The ratio of the bulk of gunpowder to the bulk of this fluid may be determined from considering that 17 drams avoirdupois of powder fill two cubic inches, if the powder be well shaken together: therefore, augmenting the number last found in the proportion of 16 to 17, the resulting term $488 \frac{1}{2}$ is the number of cubic inches of an elastic fluid, equal in density with the air produced from two cubic inches of powder: whence the ratio of the respective bulk of the powder, and of the fluid produced from it, is in round numbers as 1 to 244."— This calculation was afterwards justified by experiments.

"If this fluid, instead of expanding when the powder was fired, had been confined in the same space which the powder filled before the explosion; then it would have had, in that confined state, a degree of elasticity 244 times greater than that of common air; and this independent of the great augmentation which this elasticity would receive from the action of the fire in that instant.

"Hence, then, we are certain, that any quantity of powder, fired in a confined space, which it adequately fills, exerts, at the instant of its explosion, against the sides of the vessel containing it, and the bodies it impels before it, a force at least 244 times greater than the elasticity of the common air, or which is the same thing, than the pressure of the atmosphere; and this without considering the great addition which this force will receive from the violent degree of heat with which it is affected at that time.

"To determine how far the elasticity of air is augmented when heated to the extremest degree of red-hot iron, I took a piece of a musket-barrel about six inches in length, and ordered one end to be closed up entirely; but the other end was drawn out conically, and finished in an aperture of about $\frac{1}{4}$ of an inch in diameter. The tube thus fitted, was heated to the extremity of a red heat in a smith's forge; and was then immersed with its aperture downwards in a bucket of water, and kept there till it was cool; after which it was taken out carefully, and the water which had entered it in cooling was exactly weighed. The heat given to the tube at each time, was the beginning of what workmen call a *white heat*; and to prevent the rushing in of the aqueous vapour at the immersion which would otherwise drive out great part of the air, and render the experiment fallacious, I had an iron wire filed tapering, so as to fit the aperture of the tube, and with this I always stopped it up before it was taken from the fire, letting the wire remain in till the whole was cool, when, removing it, the due quantity of water would enter. The weight of the water thus taken in at three different trials, was 610 grains, 595 grains, and 600 grains, respectively. The content of the whole cavity of the tube was 796 grains of water; whence the spaces remaining unfilled in these three experiments were 186, 201, and 196 grains respectively. These spaces undoubtedly contained all the air which, when the tube was red hot, extended through its whole concavity; consequently the elasticity of the air, when

Theory. heated to the extreme heat of red-hot iron, was to the elasticity of the same air, when reduced to the temperature of the ambient atmosphere, as the whole capacity of the tube to the respective spaces taken up by the cooled air: that is, as 796 to 186, 201, 196; or taking the medium of these three trials, as 796 to 194 $\frac{1}{2}$.

"As air and this fluid appear to be equally affected by heat and cold, and consequently have their elasticities equally augmented by the addition of equal degrees of heat to each; if we suppose the heat with which the flame of fired powder is endowed to be the same with that of the extreme heat of red-hot iron, then the elasticity of the generated fluid will be greater at the time of the explosion than afterwards, when it is reduced to the temperature of the ambient air, in the ratio of 796 to 194 $\frac{1}{2}$ nearly. It being allowed then, (which surely is very reasonable), that the flame of gunpowder is not less hot than red-hot iron, and the elasticity of the air, and consequently of the fluid generated by the explosion, being augmented in the extremity of this heat in the ratio of 194 $\frac{1}{2}$ to 796, it follows, that if 244 be augmented in this ratio, the resulting number, which is 999 $\frac{1}{2}$, will determine how many times the elasticity of the flame of fired powder exceeds the elasticity of common air, supposing it to be confined in the same space which the powder filled before it was fired. Hence then the absolute quantity of the pressure exerted by gunpowder at the moment of its explosion may be assigned; for, since the fluid then generated has an elasticity of 999 $\frac{1}{2}$, or in round numbers 1000 times greater than that of the atmosphere, and since common air by its elasticity exerts a pressure on any given surface equal to the weight of the incumbent atmosphere with which it is in equilibrium, the pressure exerted by fired powder before it dilated itself is 1000 times greater than the pressure of the atmosphere; and consequently the quantity of ¹¹Prodigious this force, on a surface of an inch square, amounts to ¹¹power of above six tons weight; which force, however, diminishes ¹¹fired powder as the fluid dilates itself.

"But though we have here supposed that the heat of gunpowder, when fired in any considerable quantity, is the same with iron heated to the extremity of red heat, or to the beginning of a white heat, yet it cannot be doubted but that the fire produced in the explosion is somewhat varied (like all other fires) by a greater or less quantity of fuel; and it may be presumed, that, according to the quantity of powder fired together, the flame may have all the different degrees, from a languid red heat to that sufficient for the vitrification of metals. But as the quantity of powder requisite for the production of this last-mentioned heat, is certainly greater than what is ever fired together for any military purpose, we cannot be far from our scope, if we suppose the heat of such quantities as are usually fired to be nearly the same with that of red-hot iron; allowing a gradual augmentation to this heat in larger quantities, and diminishing it when the quantities are very small.

Having thus determined the force of the gunpowder, ¹²Mr Robins's method of determining the velocity with which the ball is discharged. The solution of this problem depends on the two following principles. ¹² velocities of ball. 1. That the action of the powder on the bullet ceases

Theory. as soon as the bullet is got out of the piece. 2. That all the powder of the charge is fired and converted into elastic fluid before the bullet is sensibly moved from its place.

"The first of these (says Mr Robins) will appear manifest when it is considered how suddenly the flame will extend itself on every side, by its own elasticity, when it is once got out of the mouth of the piece; for by this means its force will then be dissipated, and the bullet no longer sensibly affected by it.

13
Instantaneous firing of powder.

"The second principle is indeed less obvious, being contrary to the general opinion of almost all writers on this subject. It might, however, be sufficient for the proof of this position, to observe the prodigious compression of the flame in the chamber of the piece. Those who attend to this circumstance, and to the easy passage of the flame through the intervals of the grains, may soon satisfy themselves, that no one grain contained in that chamber can continue for any time uninfamed, when thus surrounded and pressed by such an active fire. However, not to rely on mere speculation in a matter of so much consequence, I considered, that if part only of the powder is fired, and that successively; then by laying a greater weight before the charge (suppose two or three bullets instead of one), a greater quantity of powder would necessarily be fired, since a heavier weight would be a longer time in passing through the barrel. Whence it should follow, that two or three bullets would be impelled by a much greater force than one only. But the contrary to this appears by experiment; for, firing one, two, and three bullets laid contiguous to each other with the same charge respectively, I have found that their velocities were not much different from the reciprocal of their subduplicate quantities of matter; that is, if a given charge would communicate to one bullet a velocity of 1700 feet in a second, the same charge would communicate to two bullets a velocity from 1250 to 1300 feet in a second, and to three bullets a velocity from 1050 to 1110 feet in the same time. From hence it appears, that, whether a piece is loaded with a greater or less weight of bullet, the action is nearly the same; since all mathematicians know, that if bodies, containing different quantities of matter, are successively impelled through the same space by the same power acting with a determined force at each point of that space; then the velocities given to these different bodies will be reciprocally in the subduplicate ratio of their quantities of matter. The excess of the velocities of the two and three bullets above what they ought to have been by this rule (which are that of 1200 and 980 feet in a second), undoubtedly arises from the flame, which, escaping by the side of the first bullet, acts on the surface of the second and third.

"Now, this excess has in many experiments been imperceptible, and the velocities have been reciprocally in the subduplicate ratios of the number of bullets, to sufficient exactness; and where this error has been greater, it has never arisen to an eighth part of the whole; but if the common opinion was true, that a small part only of the powder fires at first, and other parts of it successively as the bullet passes through the barrel, and that a considerable part of it is often blown out of the piece without firing at all; then the velocity

which three bullets received from the explosion ought to have been much greater than we have found it to be.—But the truth of the second postulate more fully appears from those experiments, by which it is shown, that the velocities of bullets may be ascertained to the same exactness when they are acted on through a barrel of four inches in length only, as when they are discharged from one of four feet.

Theory.

"With respect to the grains of powder which are often blown out unfired, and which are always urged as a proof of the gradual firing of the charge, I believe Diego Uffano, a person of great experience in the art of gunnery, has given the true reason for this accident; which is, that some small part of the charge is often not rammed up with the rest, but is left in the piece before the wad, and is by this means expelled by the blast of air before the fire can reach it. I must add, that in the charging of cannon and small arms, especially after the first time, this is scarcely to be avoided by any method I have yet seen practised. Perhaps, too, there may be some few grains in the best powder, of such an heterogeneous composition as to be less susceptible of firing; which, I think, I have myself observed: and these, though they are surrounded by the flame, may be driven out unfired.

14
Why some powder is blown out of the mouth of a cannon without being fired.

"These postulates being now allowed to be just, let AB (fig. 1.) represent the axis of any piece of artillery A the breech, and B the muzzle; DC the diameter of its bore, and DEGC a part of its cavity filled with powder. Suppose the ball that is to be impelled to lie with its hinder surface at the line GE; then the pressure exerted at the explosion on the circle of which GE is the diameter, or, which is the same thing, the pressure exerted in the direction FB on the surface of the ball, is easily known from the known dimensions of that circle. Draw any line FH perpendicular to FB, and AI parallel to FH: and through the point H, to the asymptotes IA and AB, describe the hyperbola KHNQ: then, if FH represents the force impelling the ball at the point F, the force impelling the ball at any other point as at M, will be represented by the line MN, the ordinate to the hyperbola at that point. For when the fluid impelling the body along has dilated itself to M, its density will be then to its original density in the space DEGC reciprocally as the spaces through which it is extended; that is, as FA to MA, or as MN to FH; but it has been shown, that the impelling force or elasticity of this fluid is directly as its density: therefore, if FH represents the force at the point F, MN will represent the like force at the point M.

15
Demonstration of the force of fired powder on the ball. Plate CCXLVIII fig. 1.

"Since the absolute quantity of the force impelling the ball at the point F is known, and the weight of the ball is also known, the proportion between the force with which the ball is impelled and its own gravity is known. In this proportion take FH to FL, and draw LP parallel to FB; then, MN the ordinate to the hyperbola in any point will be to its part MR, cut off by the line LP, as the impelling force of the powder at that point M to the gravity of the ball; and consequently the line LP will determine a line proportional to the uniform force of gravity in every point; whilst the hyperbola HNQ determines in like manner such ordinates as are proportional to the impelling force of the powder in every point; whence by the

Theory. 39th Prop. of lib. 1. of Sir Isaac Newton's Principia, the areas FLPB and FHQB are in the duplicate proportion of the velocities which the ball would acquire when acted upon by its own gravity through the space FB, and when impelled through the same space by the force of the powder. But since the ratio of AF to AB and the ratio of FH to FL are known, the ratio of the area FLPB to the area FHQB is known; and thence its subduplicate. And since the line FB is given in magnitude, the velocity which a heavy body would acquire when impelled through this line by its own gravity is known; being no other than the velocity it would acquire by falling through a space equal to that line: find then another velocity to which this last mentioned velocity bears the given ratio of the subduplicate of the area FLPB to the area FHQB; and this velocity thus found is the velocity the ball will acquire when impelled through the space FB by the action of the inflamed powder.

"Now to give an example of this: Let us suppose AB, the length of the cylinder, to be 45 inches, its diameter DC, or rather the diameter of the ball, to be $\frac{1}{4}$ ths of an inch; and AF, the extent of the powder, to be $2\frac{1}{4}$ inches; to determine the velocity which will be communicated to a leaden bullet by the explosion, supposing the bullet to be laid at first with its surface contiguous to the powder.

"By the theory we have laid down, it appears, that at the first instant of the explosion the flame will exert, on the bullet lying close to it, a force 1000 times greater than the pressure of the atmosphere. The medium pressure of the atmosphere is reckoned equal to a column of water 33 feet in height; whence, lead being to water as 11,345 to 1, this pressure will be equal to that of a column of lead 34,9 inches in height. Multiplying this by 1000, therefore, a column of lead 34,900 inches (upwards of half a mile) in height, would produce a pressure on the bullet equal to what is exerted by the powder in the first instant of the explosion; and the leaden ball being $\frac{1}{4}$ ths of an inch in diameter, and consequently equal to a cylinder of lead of the same base half an inch in height, the pressure at first acting on it will be equal to 34900×2 , or 69800 times its weight: whence FL to FH is as 1 to 69800; and FB to FA as $45 - 2\frac{1}{4}$, or $42\frac{1}{4}$ to $2\frac{1}{4}$, that is, as 339 to 21; whence the rectangle FLPB is to the rectangle AFHS as 339 to 21×69800 , that is, as 1 to 4324.—And from the known application of the logarithms to the mensuration of the hyperbolic spaces, it follows that the rectangle AFHS is to the area FHQB as 43,429, &c. is to the tabular logarithm of $\frac{AB}{AF}$; that

is, of $1\frac{60}{100}$ which is 1,2340579; whence the ratio of the rectangle FLPB to the hyperbolic area FHQB is compounded of the ratios of 1 to 4324—and of 43429, &c. to 1,2340579; which together make up the ratio of 1 to 12263, the subduplicate of which is the ratio of 1 to 110,7; and in this ratio is the velocity which the bullet would acquire by gravity in falling through a space equal to FB, to the velocity the bullet will acquire from the action of the powder impelling it through FB. But the space FB being $42\frac{1}{4}$ inches, the velocity a heavy body will acquire in falling through such a space is known to be what would

carry it nearly at the rate of 15.07 feet in a second; whence the velocity to which this has the ratio of 1 to 110,7 is a velocity which would carry the ball at the rate of 1668 feet in one second. And this is the velocity which, according to the theory, the bullet in the present circumstances would acquire from the action of the powder during the time of its dilatation.

"Now this velocity being once computed for one case, is easily applied to any other; for if the cavity DEGC left behind the bullet be only in part filled with powder, then the line HF, and consequently the area FHQB will be diminished in the proportion of the whole cavity to the part filled. If the diameter of the bore be varied, the lengths AB and AF remaining the same, then the quantity of powder and the surface of the bullet which it acts on, will be varied in the duplicate proportion of the diameter, but the weight of the bullet will vary in the triplicate proportion of the diameter; wherefore the line FH, which is directly as the absolute impelling force of the powder, and reciprocally as the gravity of the bullet, will change in the reciprocal proportion of the diameter of the bullet. If AF, the height of the cavity left behind the bullet, be increased or diminished, the rectangle of the hyperbola, and consequently the area corresponding to ordinates in any given ratio, will be increased or diminished in the same proportion. From all which it follows, that the area FHQB, which is in the duplicate proportion of the velocity of the impelled body,

will be directly as the logarithm $\frac{AB}{AF}$ (where AB represents the length of the barrel, and AF the length of the cavity left behind the bullet); also directly as the part of that cavity filled with powder; and inversely, as the diameter of the bore, or rather of the bullet, likewise directly as AF, the height of the cavity left behind the bullet. Consequently the velocity being computed as above, for a bullet of a determined diameter, placed in a piece of a given length, and impelled by a given quantity of powder, occupying a given cavity behind that bullet; it follows, that by means of these ratios, the velocity of any other bullet may be thence deduced; the necessary circumstances of its position, quantity of powder, &c. being given. Where note, That in the instance of this supposition, we have supposed the diameter of the ball to be $\frac{1}{4}$ ths of an inch; whence the diameter of the bore will be something more, and the quantity of powder contained in the space DEGC will amount exactly to 12 pennyweights, a small wad of tow included.

"In order to compare the velocities communicated to bullets by the explosion, with the velocities resulting from the theory by computation, it is necessary that the actual velocities with which bullets move should be discovered. The only methods hitherto practised for this purpose, have been either by observing the time of the flight of a shot through a given space, or by measuring the range of a shot at a given elevation; and thence computing, on the parabolic hypothesis, what degree of velocity would produce this range.—The first method labours under this insurmountable difficulty, that the velocities of these bodies are often so swift, and consequently the time observed is so short, that an imperceptible error in that time may occasion

Theory. occasion an error in the velocity thus found of 2, 3, 4, 5, or 600 feet, in a second. The other method is so fallacious, by reason of the resistance of the atmosphere (to which inequality the first is also liable), that the velocities thus assigned may not perhaps be the tenth part of the actual velocities sought.

"The simplest method of determining this velocity is by means of the instrument represented fig. 2. where ABCD represents the body of the machine composed of the three poles B, C, D, spreading at bottom, and joining together at the top A; being the same with what is vulgarly used in lifting and weighing very heavy bodies, and is called by workmen the *triangles*. On two of these poles, towards their tops, are screwed on the sockets RS; and on these sockets the pendulum EFGHIK is hung by means of its cross-piece EF, which becomes its axis of suspension, and on which it must be made to vibrate with great freedom. The body of this pendulum is made of iron, having a broad part at bottom, and its lower part is covered with a thick piece of wood GKIH, which is fastened to the iron by screws. Something lower than the bottom of the pendulum there is a brace OP, joining the two poles from which the pendulum is suspended; and to this brace there is fastened a contrivance MNU, made with two edges of steel, bearing on each other in the line UN, something in the manner of a drawing-pen; the strength with which these edges press on each other being diminished or increased at pleasure by means of a screw Z going through the upper piece. There is fastened to the bottom of the pendulum a narrow ribbon LN, which passes between these steel edges, and which afterwards by means of an opening cut in the lower piece of steel, hangs loosely down, as at W.

16
Machine
discovering
the veloci-
ties of bul-
lets.
Fig. 2.

17
Method of
using the
machine.

"This instrument thus fitted, if the weight of the pendulum be known, and likewise the respective distances of its centre of gravity, and of its centre of oscillation from its axis of suspension, it will thence be known what motion will be communicated to this pendulum by the percussion of a body of a known weight moving with a known degree of celerity, and striking it in a given point; that is, if the pendulum be supposed at rest before the percussion, it will be known what vibration it ought to make in consequence of such a determined blow; and, on the contrary, if the pendulum, being at rest, is struck by a body of a known weight, and the vibration which the pendulum makes after the blow is known, the velocity of the striking body may from thence be determined.

"Hence then, if a bullet of a known weight strikes the pendulum, and the vibration, which the pendulum makes in consequence of the stroke, be ascertained; the velocity with which the ball moved is thence to be known.

"Now the extent of the vibration made by the pendulum after the blow, may be measured to great accuracy by the ribbon LN. For let the pressure of the edges UN on the ribbon be so regulated by the screw Z, that the motion of the ribbon between them may be free and easy, though with some minute resistance; then settling the pendulum at rest, let the part LN between the pendulum and the edges be drawn strait, but not strained, and fix a pin in that part of the ribbon which is then contiguous to the edges: let now a

ball impinge on the pendulum; then the pendulum swinging back will draw out the ribbon to the just extent of its vibration, which will consequently be determined by the interval on the ribbon between the edges UN and the place of the pin.

Theory.

"The weight of the whole pendulum, wood and all, was 56 lb. 3. oz.; its centre of gravity was 52 inches distant from its axis of suspension, and 200 of its small swings were performed in the time of 253 seconds: whence its centre of oscillation (determined from hence) in 62 $\frac{3}{4}$ inches distant from that axis. The centre of the piece of wood GKIH is distant from the same axis 66 inches.

"In the compound ratio of 66 to 62 $\frac{3}{4}$, and 66 to 52, take the quantity of matter of the pendulum to a 4th quantity, which will be 42 lb. $\frac{1}{4}$ oz. Now geometers well know, that if the blow be struck on the centre of the piece of wood GKIH, the pendulum will resist to the stroke in the same manner as if this last quantity of matter only (42 lb. $\frac{1}{4}$ oz.) was concentrated in that point, and the rest of the pendulum was taken away: whence, supposing the weight of the bullet impinging in that point to be the $\frac{1}{100}$ th of a pound, or the $\frac{1}{1000}$ th of this quantity of matter nearly, the velocity of the point of oscillation after the stroke will, by the laws observed in the congress of such bodies as rebound not from each other, be the $\frac{1}{1000}$ th of the velocity the bullet moved with before the stroke; whence the velocity of this point of oscillation after the stroke being ascertained, that multiplied by 505 will give the velocity with which the ball impinged.

"But the velocity of the point of oscillation after the stroke is easily deduced from the chord of the arch, through which it ascends by the blow; for it is a well-known proposition, that all pendulous bodies ascend to the same height by their vibratory motion as they would do, if they were projected directly upwards from their lowest point, with the same velocity they have in that point; wherefore, if the versed sine of the ascending arch be found (which is easily determined from the chord and radius being given), this versed sine is the perpendicular height to which a body projected upwards with the velocity of the point of oscillation would arise; and consequently what that velocity is, can be easily computed by the common theory of falling bodies.

"For instance, the chord of the arch, described by the ascent of the pendulum after the stroke measured on the ribbon, has been sometimes 17 $\frac{1}{2}$ th inches; the distance of the ribbon from the axis of suspension is 71 $\frac{1}{2}$ th inches; whence reducing 17 $\frac{1}{2}$ th in the ratio of 71 $\frac{1}{2}$ th to 66, the resulting number, which is nearly 16 inches, will be the chord of the arch through which the centre of the board GKIH ascended after the stroke; now the versed sine of the arch, whose chord is 16 inches, and its radius 66, is 1.93939; and the velocity which would carry a body to this height, or, which is the same thing, the velocity which a body would acquire by descending through this space, is nearly that of 3 $\frac{1}{2}$ th feet in 1".

"To determine then the velocity with which the bullet impinged on the centre of the wood, when the chord of the arch described by the ascent of the pendulum, in consequence of the blow, was 17 $\frac{1}{2}$ th inches measured on the ribbon, no more is necessary than to

Theory. multiply $3\frac{1}{2}$ th by 505, and the resulting number 1641 will be the feet which the bullet would describe in 1", if it moved with the velocity it had at the moment of its percussion: for the velocity of the point of the pendulum, on which the bullet struck, we have just now determined to be that of $3\frac{1}{2}$ th feet in 1"; and we have before shown, that this is the $\frac{1}{357}$ th of the velocity of the bullet. If then a bullet weighing $\frac{1}{16}$ th of a pound strikes the pendulum in the centre of the wood GKIH, and the ribbon be drawn out $17\frac{1}{2}$ th inches by the blow; the velocity of the bullet is that of 1641 feet in 1". And since the length the ribbon is drawn is always nearly the chord of the arch described by the ascent, (it being placed so as to differ insensibly from those chords which most frequently occur), and these chords are known to be in the proportion of the velocities of the pendulum acquired from the stroke; it follows, that the proportion between the lengths of ribbon drawn out at different times, will be the same with that of the velocities of the impinging bullets; and consequently, by the proportion of these lengths of ribbon to $17\frac{1}{2}$ th, the proportion of the velocity with which the bullets impinge, to the known velocity of 1641 feet in 1", will be determined.

18
Cautions to be observed in making these experiments.

"Hence then is shown in general how the velocities of bullets of all kinds may be found out by means of this instrument; but that those who may be disposed to try these experiments may not have unforeseen difficulties to struggle with, we shall here subjoin a few observations, which it will be necessary for them to attend to, both to secure success to their trials and safety to their persons.

"And first, that they may not conceive the piece of wood GKIH to be an unnecessary part of the machine, we must inform them, that if a bullet impelled by a full charge of powder should strike directly on the iron, the bullet would be beaten into shivers by the stroke, and these shivers would rebound back with such violence, as to bury themselves in any wood they chanced to light on, as I have found by hazardous experience; and besides the danger, the pendulum will not in this instance ascertain the velocity of the bullet, because the velocity with which the parts of it rebound is unknown.

"The weight of the pendulum, and the thickness of the wood, must be in some measure proportioned to the size of the bullets which are used. A pendulum of the weight here described will do very well for all bullets under three or four ounces, if the thickness of the board be increased to seven or eight inches for the heaviest bullets; beech is the toughest and properest wood for this purpose.

"It is hazardous standing on the side of the pendulum, unless the board be so thick, that the greatest part of the bullet's force is lost before it comes at the iron; for if it strikes the iron with violence, the shivers of lead, which cannot return back through the wood, will force themselves out between the wood and iron, and will fly to a considerable distance.

"As there is no effectual way of fastening the wood to the iron but by screws, the heads of which must come through the board; the bullets will sometimes light on those screws, from whence the shivers will disperse themselves on every side.

"When in these experiments so small a quantity of

Theory. powder is used, as will not give to the bullet a velocity of more than 400 or 500 feet in 1"; the bullet will not stick in the wood, but will rebound from it entire, and (if the wood be of a very hard texture) with a very considerable velocity. Indeed I have never examined any of the bullets which have thus rebounded, but I have found them indented by the bodies they have struck against in their rebound.

"To avoid then these dangers, to the braving of which in philosophical researches no honour is annexed; it will be convenient to fix whatsoever barrel is used, on a strong heavy carriage, and to fire it with a little slow match. Let the barrel too be very well fortified in all its length; for no barrel (I speak of musket barrels) forged with the usual dimensions will bear many of the experiments without bursting. The barrel I have most relied on, and which I procured to be made on purpose, is nearly as thick at the muzzle as at the breech; that is, it has in each place nearly the diameter of its bore in thickness of metal.

"The powder used in these experiments should be exactly weighed: and that no part of it be scattered in the barrel, the piece must be charged with a ladle in the same manner as is practised with cannon; the wad should be of tow, of the same weight each time, and no more than is just necessary to confine the powder in its proper place: the length of the cavity left behind the ball should be determined each time with exactness; for the increasing or diminishing that space will vary the velocity of the shot, although the bullet and quantity of powder be not changed. The distance of the mouth of the piece from the pendulum ought to be such, that the impulse of the flame may not act on the pendulum; this will be prevented in a common barrel charged with half an ounce of powder, if it be at the distance of 16 or 18 feet: in large charges the impulse is sensible farther off; I have found it to extend to above 25 feet; however, between 25 and 18 feet is the distance I have usually chosen."

19
With this instrument, or others similar to it, Mr Account of Mr Robins made a great number of experiments on barrels of different lengths, and with different charges of powder. He hath given us the results of 61 of these; and having compared the actual velocities with the computed ones, his theory appears to have come as near the truth as could well be expected. In seven of the experiments there was a perfect coincidence; the charges of powder being six to twelve pennyweights; the barrels 4.5, 24.312, and 7.06 inches in length. The diameter of the first (marked A) was $\frac{1}{8}$ th of an inch; of the second (B) was the same; and of D, $\frac{1}{8}$ of an inch. In the first of these experiments, another barrel (C) was used, whose length was 12.375 inches, and the diameter of its bore $\frac{1}{8}$ th inch.—In 14 more of the experiments, the difference between the length of the chord of the pendulum's arch shown by the theory and the actual experiment was $\frac{1}{100}$ th of an inch over or under. This showed an error in the theory varying according to the different lengths of the chord from $\frac{1}{100}$ th to $\frac{1}{200}$ th of the whole; the charges of powder were the same as in the last.—In 16 other experiments the error was $\frac{1}{100}$ ths of an inch, varying from $\frac{1}{100}$ th to $\frac{1}{200}$ th of the whole; the charges of powder were 6, 8, 9, or 12 pennyweights.—In seven other experiments, the error was $\frac{1}{100}$ ths of an inch, varying from $\frac{1}{100}$ th to $\frac{1}{200}$ th of

Theory. $\frac{1}{17}$ of the whole; the charges of powder six or twelve pennyweights. In eight experiments, the difference was $\frac{4}{10}$ ths of an inch, indicating an error from $\frac{1}{17}$ to $\frac{4}{17}$ of the whole; the charges being 6, 9, 12, and 24 pennyweights of powder. In three experiments, the error was $\frac{1}{10}$ ths, varying from $\frac{1}{17}$ th to $\frac{1}{10}$ th of the whole; the charges 8 and 12 pennyweights of powder. In two experiments the error was $\frac{6}{10}$ ths, in one case amounting to something less than $\frac{1}{17}$, in the other to $\frac{1}{17}$ of the whole; the charges 12 and 36 pennyweights of powder. By one experiment the error was seven, and by another eight, tenths; the first amounting to $\frac{1}{10}$ th nearly, the latter to almost $\frac{1}{10}$ th of the whole: the charges of powder 6 or 12 pennyweights. The last error, however, Mr Robins ascribes to the wind. The two remaining experiments varied from theory by 1.3 inches, somewhat more than $\frac{1}{10}$ th of the whole: the charges of powder were 12 pennyweights in each; and Mr Robins ascribes the error to the dampness of the powder. In another case, he ascribes an error of $\frac{6}{10}$ ths to the blast of the powder on the pendulum.

His conclusions from them. From these experiments Mr Robins deduces the following conclusions. "The variety of these experiments, and the accuracy with which they correspond to the theory, leave us no room to doubt of its certainty. This theory, as here established, supposes, that, in the firing of gunpowder, about $\frac{1}{10}$ ths of its substance is converted by the sudden inflammation into a permanently elastic fluid, whose elasticity, in proportion to its heat and density, is the same with that of common air in the like circumstances; it farther supposes, that all the force exerted by gunpowder in its most violent operations, is no more than the action of the elasticity of the fluid thus generated; and these principles enable us to determine the velocities of bullets impelled from fire-arms of all kinds; and are fully sufficient for all purposes where the force of gunpowder is to be estimated.

"From this theory many deductions may be made of the greatest consequence to the practical part of gunnery. From hence the thickness of a piece, which will enable it to confine, without bursting, any given charge of powder, is easily determined, since the effort of the powder is known. From hence appears the inconclusiveness of what some modern authors have advanced, relating to the advantages of particular forms of chambers for mortars and cannon; for all their laboured speculations on this head are evidently founded on very erroneous opinions about the action of fired powder. From this theory too we are taught the necessity of leaving the same space behind the bullet, when we would, by the same quantity of powder, communicate to it an equal degree of velocity; since, on the principles already laid down, it follows, that the same powder has a greater or less degree of elasticity, according to the different spaces it occupies. The method which I have always practised for this purpose has been by marking the rammer; and this is a maxim which ought not to be dispensed with when cannon are fired at an elevation, particularly in those called by the French *batteries à ricochet*.

"From the continued action of the powder, and its manner of expanding described in this theory, and the length and weight of the piece, one of the most essen-

tial circumstances in the well directing of artillery may be easily ascertained. All practitioners are agreed, that no shot can be depended on, unless the piece be placed on a solid platform: for if the platform shakes with the first impulse of the powder, it is impossible but the piece must also shake: which will alter its direction, and render the shot uncertain. To prevent this accident, the platform is usually made extremely firm to a considerable depth backwards; so that the piece is not only well supported in the beginning of its motion, but likewise through a great part of its recoil. However, it is sufficiently obvious, that when the bullet is separated from the piece, it can be no longer affected by the trembling of the piece or platform; and, by a very easy computation, it will be found, that the bullet will be out of the piece before the latter hath recoiled half an inch: whence, if the platform be sufficiently solid at the beginning of the recoil, the remaining part of it may be much slighter; and hence a more compendious method of constructing platforms may be found out.

"From this theory also it appears how greatly these authors have been mistaken, who have attributed the force of gunpowder, or at least a considerable part of it, to the action of the air contained either in the powder or between the intervals of the grains; for they have supposed that air to exist in its natural elastic state, and to receive all its addition of force from the heat of the explosion. But from what hath been already delivered concerning the increase of the air's elasticity by heat, we may conclude that the heat of the explosion cannot augment this elasticity to five times its common quantity; consequently the force arising from this cause only cannot amount to more than the 200th part of the real force exerted on the occasion.

"If the whole substance of the powder was converted into an elastic fluid at the instant of the explosion, then from the known elasticity of this fluid assigned by our theory, and its known density, we could easily determine the velocity with which it would begin to expand, and could thence trace out its future augmentations in its progress through the barrel: but as we have shown that the elastic fluid, in which the activity of the gunpowder consists, is only $\frac{1}{10}$ ths of the substance of the powder, the remaining $\frac{9}{10}$ ths will, in the explosion, be mixed with the elastic part, and will by its weight retard the activity of the explosion; and yet they will not be so completely united as to move with one common motion; but the unelastic part will be less accelerated than the rest, and some will not even be carried out of the barrel, as appears by the considerable quantity of unctuous matter which adheres to the inside of all fire-arms after they have been used. These inequalities in the expansive motion of the flame oblige us to recur to experiments for its accurate determination.

"The experiments made use of for this purpose were Experimental of two kinds. The first was made by charging the barrel A with 12 pennyweights of powder, and a small wad of tow only; and then placing its mouth of inches from the centre of the pendulum. On firing it in this situation, the impulse of the flame made it ascend through an arch whose chord was 13.7 inches; whence, if the whole substance of the powder was supposed to strike against the pendulum, and each part to strike

Theory.

Theory. strike with the same velocity, that common velocity must have been at the rate of about 2650 feet in a second.—But as some part of the velocity of the flame was lost in passing through 19 inches of air; I made the remaining experiments in a manner not liable to this inconvenience.

“ I fixed the barrel A on the pendulum, so that its axis might be both horizontal and also perpendicular to the plane HK; or, which is the same thing, that it might be in the plane of the pendulum's vibration: the height of the axis of the piece above the centre of the pendulum was six inches; and the weight of the piece, and of the iron that fastened it, &c. was $12\frac{1}{2}$ lb. The barrel in this situation being charged with 12 pennyweights of powder, without either ball or wad, only put together with the rammer; on the discharge the pendulum ascended through an arch whose chord was 10 inches, or reduced to an equivalent blow in the centre of the pendulum, supposing the barrel away, it would be 14.4 inches nearly.—The same experiment being repeated, the chord of the ascending arch was 10.1 inches, which, reduced to the centre, is 14.6 inches.

“ To determine what difference of velocity there was in the different parts of the vapour, I loaded the piece again with 12 pennyweights of powder, and rammed it down with a wad of tow, weighing one pennyweight. Now, I conceived that this wad being very light, would presently acquire that velocity with which the elastic part of the fluid would expand itself when uncompressed; and I accordingly found, that the chord of the ascending arch was by this means increased to 12 inches, or at the centre to 17.3: whence, as the medium of the other two experiments is 14.5, the pendulum ascended through an arch 2.8 inches longer, by the additional motion of one pennyweight of matter, moving with the velocity of the swiftest part of the vapour; and consequently the velocity with which this pennyweight of matter moved, was that of about 7000 feet in a second.

“ It will perhaps be objected to this determination, that the augmentation of the arch through which the pendulum vibrated in this case was not all of it owing to the quantity of motion given to the wad, but part of it was produced by the confinement of the powder, and the greater quantity thereby fired. But if it were true that a part only of the powder fired when there was no wad, it would not happen that in firing different quantities of powder without a wad, the chord would increase and decrease nearly in the ratio of these quantities; which yet I have found it to do: for with nine pennyweights that chord was 7.3 inches, which with 12 pennyweights we have seen was only 10, and 10.1 inches; and even with three pennyweights the chord was two inches; deficient from this proportion by .5 only; for which defect two other valid reasons are to be assigned.

“ And there is still a more convincing proof that all the powder is fired, although no wad be placed before the charge, which is, that the part of the recoil arising from the expansion of powder alone is found to be no greater when it impels a leaden bullet before it, than when the same quantity is fired without any wad to confine it. We have seen that the chord of the arch

Theory. through which the pendulum rose from the expansive force of the powder alone is 10, or 10.1; and the chord of that arch, when the piece was charged in the customary manner with a bullet and wad, I found to be the first time $22\frac{1}{2}$, and the second $22\frac{1}{2}$, or at a medium 22.56. Now the impulse of the ball and wad, if they were supposed to strike the pendulum in the same place in which the barrel was suspended, with the velocity they had acquired at the mouth of the piece, would drive it through an arch whose chord would be about 12.3; as is known from the weight of the pendulum, the weight and position of the barrel, and the velocity of the bullet determined by our former experiments; whence, subtracting this number 12.3 from 22.56, the remainder 10.26 is nearly the chord of the arch which the pendulum would have ascended through from the expansion of the powder alone with a bullet laid before it. And this number, 10.26, differs but little from 10.1, which we have above found to be the chord of the ascending arch, when the same quantity of powder expanded itself freely without either bullet or wad before it.

“ Again, that this velocity of 7000 feet in a second is not much beyond what the most active part of the flame acquires in expanding, is evinced from hence, that in some experiments a ball has been found to be discharged with a velocity of 2400 feet in a second; and yet it appeared not that the action of the powder was at all diminished on account of this immense celerity: consequently the degree of swiftness with which, in this instance, the powder followed the ball without losing any part of its pressure, must have been much short of what the powder alone would have expanded with, had not the ball been there.

“ From these determinations may be deduced the force of petards; since their action depends entirely on the impulse of the flame; and it appears that a quantity of powder properly disposed in such a machine, may produce as violent an effort as a bullet of twice its weight, moving with a velocity of 1400 or 1500 feet in a second.

“ In many of the experiments already recited, the A bullet ball was not laid immediately contiguous to the powder, but at a small distance, amounting, at the utmost, only to an inch and a half. In these cases the theory ^{lies off with the greatest velocity when} agreed very well with the experiments. But if a bullet is placed at a greater distance from the powder, suppose at 12, 18, or 24 inches, we cannot then apply to this ball the same principles which may be applied to those laid in contact, or nearly so, with the powder; for when the surface of the fired powder is not confined by a heavy body, the flame dilates itself with a velocity far exceeding that which it can communicate to a bullet by its continued pressure: consequently, as at the distance of 12, 18, or 24 inches, the powder will have acquired a considerable degree of this velocity of expansion, the first motion of the ball will not be produced by the continued pressure of the powder, but by the actual percussion of the flame; and it will therefore begin to move with a quantity of motion proportioned to the quantity of this flame, and the velocities of its respective parts.

“ From hence then it follows, that the velocity of the bullet, laid at a considerable distance before the charge,

Theory. charge, ought to be greater than what would be communicated to it by the pressure of the powder acting in the manner already mentioned: and this deduction from our theory we have confirmed by manifold experience; by which we have found, that a ball laid in the barrel A, with its hinder part $11\frac{1}{2}$ inches from its breech, and impelled by 12 pennyweights of powder, has acquired a velocity of about 1400 feet in a second; when if it had been acted on by the pressure of the flame only, it would not have acquired a velocity of 1200 feet in a second. The same we have found to hold true in all other greater distances (and also in lesser, though not in the same degree), and in all quantities of powder: and we have likewise found, that these effects nearly correspond with what has been already laid down about the velocity of expansion and the elastic and unelastic parts of the flame.

“ From hence too arises another consideration of great consequence in the practice of gunnery; which is, that no bullet should at any time be placed at a considerable distance from the charge, unless the piece is extremely well fortified: for a moderate charge of powder, when it has expanded itself through the vacant space, and reaches the ball, will, by the velocity each part has acquired, accumulate itself behind the ball, and thereby be condensed prodigiously; whence, if the barrel be not extremely firm in that part, it must, by means of this reinforced elasticity, infallibly burst. The truth of this reasoning I have experienced in an exceeding good Tower-musket, forged of very tough iron; for charging it with 12 pennyweights of powder, and placing the ball 16 inches from the breech, on firing it, the part of the barrel just behind the bullet was swelled out to double its diameter like a blown bladder, and two large pieces of two inches long were burst out of it.

“ Having seen that the entire motion of a bullet laid at a considerable distance from the charge, is acquired by two different methods in which the powder acts on it; the first being the percussion of the parts of the flame with the velocity they had respectively acquired by expanding, the second the continued pressure of the flame through the remaining part of the barrel; I endeavoured to separate these different actions, and to retain that only which arose from the continued pressure of the flame. For this purpose I no longer placed the powder at the breech, from whence it would have full scope for its expansion; but I scattered it as uniformly as I could through the whole cavity left behind the bullet; imagining that by this means the progressive velocity of the flame in each part would be prevented by the expansion of the neighbouring parts; and I found, that the ball being laid $11\frac{1}{2}$ inches from the breech, its velocity, instead of 1400 feet in a second, which it acquired in the last experiments, was now no more than 1100 feet in the second, which is 100 feet short of what according to the theory should arise from the continued pressure of the powder only.

“ The reason of this deficiency was, doubtless, the intestine motion of the flame: for the ascension of the powder thus distributed through so much larger a space than it could fill, must have produced many reverberations and pulsations of the flame; and from these internal agitations of the fluid, its pressure on the containing surface will (as is the case of all other fluids) be considerably diminished; and in order to avoid this

irregularity, in all other experiments I took care to have the powder closely confined in as small a space as possible, even when the bullet lay at some little distance from it.

“ With regard to the resistance of the air, which so remarkably affects all military projectiles, it is necessary to premise, that the greatest part of authors have established it as a certain rule, that while the same body moves in the same medium, it is always resisted in the duplicate proportion of its velocity; that is, if the resisted body move in one part of its track with three times the velocity with which it moved in some other part, then its resistance to the greater velocity will be nine times the resistance to the lesser. If the velocity in one place be four times greater than in another, the resistance of the fluid will be 16 times greater in the first than in the second, &c. This rule, however, though pretty near the truth when the velocities are confined within certain limits, is excessively erroneous when applied to military projectiles, where such resistances often occur as could scarcely be effected, on the commonly received principles, even by a treble augmentation of its density.

“ By means of the machine already described, I have it in my power to determine the velocity with which a ball moves in any part of its track, provided I can direct the piece in such a manner as to cause the bullet to impinge on the pendulum placed in that part: and therefore, charging a musket barrel three times successively with a leaden ball three-fourths of an inch in diameter, and about half its weight of powder; and taking such precaution in weighing of the powder and placing it, that I was assured, by many previous trials, that the velocity of the ball could not differ by 20 feet in a second from its medium quantity; I fired it against the pendulum placed at 25, 75, and 125 feet distance from the mouth of the piece respectively; and I found that it impinged against the pendulum, in the first case, with a velocity of 1670 feet in a second; in the second case, with a velocity of 1550 feet in a second; and in the third case, with a velocity of 1425 feet in a second; so that, in passing through 50 feet of air, the bullet lost a velocity of 120 or 125 feet in a second; and the time of its passing through that space being about $\frac{1}{14}$ or $\frac{1}{15}$ of a second, the medium quantity of resistance must, in these instances, have been about 120 times the weight of the ball; which (as the ball was nearly $\frac{1}{16}$ of a pound) amounts to about 10lb. avoirdupois.

Now, if a computation be made according to the method laid down for compressed fluids in the 38th proposition of Newton's *Principia*, supposing the weight of water to that of air as 850 to 1, it will be found, that the resistance to a globe of three-fourths of an inch diameter, moving with a velocity of about 1600 feet in a second, will not, on these principles, amount to any more than $4\frac{1}{2}$ lb. avoirdupois; whence, as we know that the rules contained in that proposition are very accurate with regard to slow motions, we may hence conclude, that the resistance of the air in slow motions is less than that in swift motions, in the ratio of $4\frac{1}{2}$ to 10; a proportion between that of 1 to 2, and 1 to 3.

“ Again, I charged the same piece a number of times with equal quantities of powder, and balls of the same weight, taking all possible care to give to

Theory.

⁸³ Of the resistance of the air to the motion of bullets.

Theory. every shot an equal velocity; and firing three times against the pendulum placed only 25 feet from the mouth of the piece, the medium of the velocities with which the ball impinged was nearly that of 1690 feet in a second: then removing the piece 175 feet from the pendulum, I found, taking the medium of five shots, that the velocity with which the ball impinged at this distance was 1300 feet in a second; whence the ball, in passing through 150 feet of air, lost a velocity of about 390 feet in a second; and the resistance computed from these numbers comes out something more than in the preceding instance, it amounting here to between 11 and 12 pounds avoirdupois; whence, according to these experiments, the resisting power of the air to swift motions is greater than to slow ones, in a ratio which approaches nearer to that of 3 to 1 than in the preceding experiments.

“ Having thus examined the resistance to a velocity of 1700 feet in a second, I next examined the resistance to smaller velocities: and for this purpose I charged the same barrel with balls of the same diameter, but with less powder, and placing the pendulum at 25 feet distance from the piece, I fired against it five times with an equal charge each time: the medium velocity with which the ball impinged, was that of 1180 feet in a second; then, removing the pendulum to the distance of 250 feet, the medium velocity of five shots, made at this distance, was that of 950 feet in a second: whence the ball, in passing through 225 feet of air, lost a velocity of 230 feet in a second: and as it passed through that interval in about $\frac{1}{2}$ of a second, the resistance to the middle velocity will come out to be near $3\frac{3}{4}$ times the gravity of the ball, or 2 lb. 10 oz. avoirdupois. Now, the resistance to the same velocity, according to the laws observed in slower motions, amounts to $\frac{1}{17}$ of the same quantity; whence, in a velocity of 1065 feet in a second, the resisting power of the air is augmented in no greater a proportion than that of 7 to 11; whereas we have seen in the former experiments, that to still greater degrees of velocity the augmentation approached very near the ratio of one to three.

“ But farther, I fired three shot, of the same size and weight with those already mentioned, over a large piece of water; so that their dropping into the water being very discernible, both the distance and time of their flight might be accurately ascertained. Each shot was discharged with a velocity of 400 feet in a second; and I had satisfied myself by many previous trials of the same charge with the pendulum, that I could rely on this velocity to ten feet in a second. The first shot flew 313 yards in four seconds and a quarter, the second flew 319 yards in four seconds, and the third 373 yards in five seconds and a half. According to the theory of resistance established for slow motions, the first shot ought to have spent no more than 3.2 seconds in its flight, the second 3.28, and the third 4 seconds; whence it is evident, that every shot was retarded considerably more than it ought to have been had that theory taken place in its motion; consequently the resistance of the air is very sensibly increased, even in such a small velocity as that of 400 feet in a second.

“ As no large shot are ever projected in practice with velocities exceeding that of 1700 feet in a second,

it will be sufficient for the purposes of a practical gunner to determine the resistance to all lesser velocities; which may be thus exhibited. Let AB (fig. 3.) be taken to AC, in the ratio of 1700 feet in a second to the given velocity to which the resisting power of the air is required. Continue the line AB to D, so that BD may be to AD, as the resisting power of the air to slow motions is to its resisting power to a velocity of 1700 feet in a second; then shall CD be to AD as the resisting power of the air to slow motions is to its resisting power to the given velocity represented by AC.

“ From the computations and experiments already mentioned, it plainly appears, that a leaden ball of three-fourths of an inch diameter, and weighing nearly $1\frac{7}{8}$ oz. avoirdupois, if it be fired from a barrel of 45 inches in length, with half its weight of powder, will issue from that piece with a velocity which, if it were uniformly continued, would carry it near 1700 feet in a second.—If, instead of the leaden ball, an iron one, of an equal diameter, was placed in the same situation in the same piece, and was impelled by an equal quantity of powder, the velocity of such an iron bullet would be greater than that of a leaden one in the subduplicate ratio of the specific gravities of lead and iron; and supposing that ratio to be as three to two, and computing on the principles already laid down, it will appear, that an iron bullet of 24lb. weight, shot from a piece of 10 feet in length, with 16lb. of powder, will acquire from the explosion a velocity which, if uniformly continued, would carry it nearly 1650 feet in a second.

“ This is the velocity which, according to our theory, a cannon ball of 24lb. weight is discharged with when it is impelled by a full charge of powder; but if, instead of a quantity of powder weighing two-thirds of the ball, we suppose the charge to be only half the weight of it, then its velocity will on the same principles be no more than 1490 feet in a second. The same would be the velocities of every lesser bullet fired with the same proportions of powder, if the lengths of all pieces were constantly in the same ratio with the diameters of their bore; and although, according to the usual dimensions of the smaller pieces of artillery, this proportion does not always hold, yet the difference is not great enough to occasion a very great variation from the velocities here assigned; as will be obvious to any one who shall make a computation thereon. But in these determinations we suppose the windage to be no more than is just sufficient for putting down the bullet easily; whereas in real service, either through negligence or unskillfulness, it often happens, that the diameter of the bore so much exceeds the diameter of the bullet, that great part of the inflamed fluid escapes by its side; whence the velocity of the shot in this case may be considerably less than what we have assigned. However, this perhaps may be compensated by the greater heat which in all probability attends the firing of these large quantities of powder.

“ From this great velocity of cannon shot we may clear up the difficulty concerning the point-blank shot which occasioned the invention of Anderson's strange hypothesis*. Here our author was deceived by his not knowing how greatly the primitive velocity of the heaviest shot is diminished in the course of its flight by

Theory.
Plate
CCXLVIII
fig. 3.

²⁴
Solution
of the difficulty
concerning
point-blank
shot.
* See No. 5.

Theory. the resistance of the air. And the received opinion of practical gunners is not more difficult to account for; since, when they agree that every shot flies in a straight line to a certain distance from the piece, which imaginary distance they have called the *extent of the point-blank shot*, we need only suppose, that, within that distance which they thus determine, the deviation of the path of the shot from a straight line is not very perceptible in their method of pointing. Now, as a shot of 24lb. fired with two thirds of its weight of powder, will, at the distance of 500 yards from the piece, be separated from the line of its original direction by an angle of little more than half a degree; those who are acquainted with the inaccurate methods often used in the directing of cannon will easily allow, that so small an aberration may not be attended to by the generality of practitioners, and the path of the shot may consequently be deemed a straight line; especially as other causes of error will often intervene much greater than what arises from the incurvation of this line by gravity.

25 By increasing the quantity of powder, the velocity of the shot will not continually increase.

“ We have now determined the velocity of the shot both when fired with two-thirds of its weight and with half its weight of powder respectively; and on this occasion I must remark, that on the principles of our theory, the increasing charge of powder will increase the velocity of the shot till the powder arrives at a certain quantity; after which, if the powder be increased, the velocity of the shot will diminish. The quantity producing the greatest velocity and the proportion between that greatest velocity and the velocity communicated by greater and lesser charges, may be thus assigned. Let AB represent the axis of the piece; draw AC perpendicular to it, and to the asymptotes AC and AB draw any hyperbola LF, and draw BF parallel to AC; find out now the point D, where the rectangle ADEG is equal to the hyperbolic area DEFB; then will AD represent that height of the charge which communicates the greatest velocity to the shot: whence AD being to AB as 1 to 2.71828, as appears from the table of logarithms, from the length of the line AD thus determined, and the diameter of the bore, the quantity of powder contained in this charge is easily known. If, instead of this charge, any other filling the cylinder to the height AI, be used, draw IH parallel to AC, and through the point H to the same asymptotes AC and AB describe the hyperbola HK; then the greatest velocity will be to the velocity communicated by the charge AI, in the subduplicate proportion of the rectangle ADEG to the same rectangle diminished by the trilinear space KHE.

26 Exceeding great resistance of the air.

“ It hath been already shown, that the resistance of the air on the surface of a bullet of three-fourths of an inch diameter, moving with a velocity of 1670 feet in a second, amounted to about 10lb. It hath also been shown, that an iron bullet weighing 24lb. if fired with 16lb. of powder (which is usually esteemed its proper battering charge), acquires a velocity of about 1650 feet in a second, scarcely differing from the other: whence, as the surface of this last bullet is more than 54 times greater than the surface of a bullet of three-fourths of an inch diameter, and their velocities are nearly the same, it follows, that the resistance on the larger bullet will amount to more than 540lb. which is near 23 times its own weight.

VOL. X. Part I.

“ The two last propositions are principally aimed against those theorists who have generally agreed in supposing the flight of shot and shells to be nearly in the curve of a parabola. The reason given by those authors for their opinion is the supposed inconsiderable resistance of the air; since as it is agreed on all sides that the track of projectiles would be a perfect parabola if there was no resistance, it has from thence been too rashly concluded, that the interruption which the ponderous bodies of shells and bullets would receive from such a rare medium as air would be scarcely sensible, and consequently that their parabolic flight would be hereby scarcely affected.

“ Now the prodigious resistance of the air to a bullet of 24lb. weight, such as we have here established it, sufficiently confutes this reasoning; for how erroneous must that hypothesis be, which neglects as inconsiderable a force amounting to more than 20 times the weight of the moving body?” But here it is necessary to assume a few particulars, the demonstrations of which, on the commonly received principles, may be seen under the article PROJECTILES.

27 Common maxims concerning the motion of projectiles.

“ 1. If the resistance of the air be so small that the motion of a projected body is in the curve of a parabola, then the axis of that parabola will be perpendicular to the horizon, and consequently the part of the curve in which the body ascends will be equal and similar to that in which it descends.

“ 2. If the parabola in which the body moves be terminated on a horizontal plane, then the vertex of the parabola will be equally distant from its own extremities.

“ 3. Also the moving body will fall on that horizontal plane in the same angle, and with the same velocity with which it was first projected.

“ 4. If a body be projected in different angles but with the same velocity, then its greatest horizontal range will be when it is projected in an angle of 45° with the horizon.

“ 5. If the velocity with which the body is projected be known, then this greatest horizontal range may be thus found. Compute, according to the common theory of gravity, what space the projected body ought to fall through to acquire the velocity with which it is projected: then twice that space will be the greatest horizontal range, or the horizontal range when the body is projected in an angle of 45° with the horizon.

“ 6. The horizontal ranges of a body, when projected with the same velocity at different angles, will be between themselves as the sines of twice the angle in which the line of projection is inclined to the horizon.

“ 7. If a body is projected in the same angle with the horizon, but with different velocities, the horizontal ranges will be in the duplicate proportion of those velocities.

28 Prodigious errors of the common theory.

“ These postulates, which contain the principles of the modern art of gunnery, are all of them false; for it hath been already shown, that a musket ball of three-fourths of an inch in diameter, fired with half its weight of powder, from a piece 45 inches long, moves with a velocity of near 1700 feet in a second. Now, if this ball flew in the curve of a parabola, its horizontal range at 45° would be found by the fifth postulate to

Theory.

be about 17 miles. But all the practical writers assure us, that this range is really short of half a mile. Diego Ufano assigns to an arquebuss, four feet in length, and carrying a leaden ball of $1\frac{1}{2}$ oz. weight (which is very near our dimensions), a horizontal range of 797 common paces, when it is elevated between 40 and 50 degrees, and charged with a quantity of fine powder equal in weight to the ball. Mersennus also tells us, that he found the horizontal range of an arquebuss at 45° to be less than 400 fathoms, or 800 yards; whence, as either of these ranges are short of half an English mile, it follows, that a musket shot, when fired with a reasonable charge of powder at the elevation of 45° , flies not one-thirty-fourth part of the distance it ought to do if it moved in a parabola. Nor is this great contraction of the horizontal range to be wondered at, when it is considered that the resistance of this bullet when it first issues from the piece amounts to 120 times its gravity, as hath been experimentally demonstrated, N^o 23.

“To prevent objections, our next instance shall be in an iron bullet of 24lb. weight, which is the heaviest in common use for land-service. Such a bullet fired from a piece of the common dimensions with its greatest allotment of powder hath a velocity of 1650 feet in a second, as already shown. Now, if the horizontal range of this shot at 45° be computed on the parabolic hypothesis by the fifth postulate, it will come out to be about 16 miles, which is between five and six times its real quantity; for the practical writers all agree in making it less than three miles.

“But farther, it is not only when projectiles move with these very great velocities that their flight sensibly varies from the curve of a parabola; the same aberration often takes place in such as move slow enough to have their motion traced out by the eye; for there are few projectiles that can be thus examined, which do not visibly disagree with the first, second, and third postulates; obviously descending through a curve, which is shorter and less inclined to the horizon than that in which they ascended. Also the highest point of their flight, or the vertex of the curve, is much nearer the place where they fall to the ground than to that from whence they were at first discharged.

“I have found too by experience, that the fifth, sixth, and seventh postulates are excessively erroneous when applied to the motions of bullets moving with small velocities. A leaden bullet three-fourths of an inch in diameter, discharged with a velocity of about 400 feet in a second, and in an angle of $19^\circ 5'$ with the horizon, ranged on the horizontal plane no more than 448 yards: whereas its greatest horizontal range being found by the fifth postulate to be at least 1700 yards, the range at $19^\circ 5'$ ought by the sixth postulate to have been 1050 yards: whence, in this experiment, the range was not three-sevenths of what it must have been, had the commonly received theory been true.”

From this and other experiments it is clearly proved, that the track described by the flight even of the heaviest shot, is neither a parabola, nor approaching to a parabola, except when they are projected with very small velocities. The nature of the curve really described by them is explained under the article PROJECTILES. But as a specimen of the great complica-

tion of that subject, we shall here insert an account of a very extraordinary circumstance which frequently takes place therein.

“As gravity acts perpendicularly to the horizon, it is evident, that if no other power but gravity deflected a projected body from its course, its motion would be constantly performed in a plane perpendicular to the horizon, passing through the line of its original direction; but we have found, that the body in its motion often deviates from this plane, sometimes to the right hand and at other times to the left: and this in an incurvated line, which is convex towards that plane, so that the motion of a bullet is frequently in a line having a double curvature, it being bent towards the horizon by the force of gravity, and again bent out of its original direction to the right or left by some other force: in this case no part of the motion of the bullet is performed in the same plane, but its track will lie in the surface of a kind of cylinder, whose axis is perpendicular to the horizon.

“This proposition may be indisputably proved by the experience of every one in the least conversant with the practice of gunnery. The same piece which will carry its bullet within an inch of the intended mark at 10 yards distance, cannot be relied on to 10 inches in 100 yards, much less to 30 inches in 300 yards. Now this inequality can only arise from the track of the bullet being incurvated sidewise as well as downwards: for by this means the distance between that incurvated line and the line of direction will increase in a much greater ratio than that of the distance; these lines being coincident at the mouth of the piece, and afterwards separating in the manner of a curve and its tangent, if the mouth of the piece be considered as the point of contact. To put this matter out of all doubt, however, I took a barrel carrying a ball three-fourths of an inch diameter, and fixing it on a heavy carriage, I satisfied myself of the steadiness and truth of its direction, by firing at a board $1\frac{1}{4}$ feet square, which was placed at 180 feet distance; for I found that in 16 successive shots I missed the mark but once. Now, the same barrel being fixed on the same carriage, and fired with a smaller quantity of powder, so that the shock on the discharge would be much less, and consequently the direction less changed, I found, that at 760 yards distance the ball flew sometimes 100 yards to the right of the line it was pointed on, and sometimes as much to the left. I found too, that its direction in the perpendicular line was not less uncertain, it falling one time above 200 yards short of what it did at another; although, by the nicest examination of the piece after the discharge, it did not appear to have started in the least from the position it was placed in.

“The reality of this doubly curvated track being thus demonstrated, it may perhaps be asked, What can be the cause of a motion so different from what has been hitherto supposed? And to this I answer, That the deflection in question must be owing to some power acting obliquely to the progressive motion of the body; which power can be no other than the resistance of the air. If it be farther asked, how the resistance of the air can ever come to be oblique to the progressive motion of the body? I farther reply, that it may sometimes arise from inequalities in the resisted surface; but that its general cause is doubtless a whirling motion

29
Rotatory motion of bullets is a great source of deflection.

Theory. tion acquired by the bullet about its axis: for by this motion of rotation, combined with the progressive motion, each part of the bullet's surface will strike the air very differently from what it would do if there was no such whirl; and the obliquity of the action of the air arising from this cause will be greater, as the motion of the bullet is greater in proportion to its progressive one.

"This whirling motion undoubtedly arises from the friction of the bullet against the sides of the piece; and as the rotatory motion will in some part of its revolution conspire with the progressive one, and in another part be equally opposed to it, the resistance of the air on the fore part of the bullet will be hereby affected, and will be increased in that part where the whirling motion conspires with the progressive one, and diminished where it is opposed to it; and by this means the whole effort of the resistance, instead of being opposite to the direction of the body, will become oblique thereto, and will produce those effects already mentioned. If it was possible to predict the position of the axis round which the bullet should whirl, and if that axis was unchangeable during the whole flight of the bullet, then the aberration of the bullet by this oblique force would be in a given direction; and the incurvation produced thereby would regularly extend the same way from one end of its track to the other. For instance, if the axis of the whirl was perpendicular to the horizon, then the incurvation would be to the right or left. If that axis was horizontal, and perpendicular to the direction of the bullet, then the incurvation would be upwards or downwards. But as the first position of this axis is uncertain, and as it may perpetually shift in the course of the bullet's flight; the deviation of the bullet is not necessarily either in one certain direction, or tending to the same side in one part of its track more than it does in another, but more usually is continually changing the tendency of its deflection, as the axis round which it whirls must frequently shift its position to the progressive motion by many inevitable accidents.

"That a bullet generally acquires such a rotatory motion, as here described, is, I think, demonstrable: however, to leave no room for doubt or dispute, I confirmed it, as well as some other parts of my theory, by the following experiments.

"I caused the machine to be made represented **fig. 4.** BCDE is a brass barrel, moveable on its axis, and so adjusted by means of friction-wheels, not represented in the figure, as to have no friction worth attending to. The frame in which this barrel is fixed is so placed that its axis may be perpendicular to the horizon. The axis itself is continued above the upper plate of the frame, and has fastened on it a light hollow cone, AFG. From the lower part of this cone there is extended a long arm of wood, GH, which is very thin, and cut feather-edged. At its extremity there is a contrivance for fixing on the body, whose resistance is to be investigated (as here the globe P); and to prevent the arm GH from swaying out of its horizontal position by the weight of the annexed body P, there is a brace, AH, of fine wire, fastened to the top of the cone which supports the end of the arm.

"Round the barrel BCDE, there is wound a fine silk line, the turns of which appear in the figure; and

after this line hath taken a sufficient number of turns, it is conducted nearly in a horizontal direction to the pulley L, over which it is passed, and then a proper weight M is hung to its extremity. If this weight be left at liberty, it is obvious that it will descend by its own gravity, and will, by its descent, turn round the barrel BCDE, together with the arm GH, and the body P fastened to it. And whilst the resistance on the arm GH and on the body P is less than the weight M, that weight will accelerate its motion; and thereby the motion of GH and P will increase, and consequently their resistance will increase, till at last this resistance and the weight M become nearly equal to each other. The motion with which M descends, and with which P revolves, will not then sensibly differ from an equable one. Whence it is not difficult to conceive, that, by proper observations made with this machine, the resistance of the body P may be determined. The most natural method of proceeding in this investigation is as follows: Let the machine first have acquired its equable motion, which it will usually do in about five or six turns from the beginning; and then let it be observed, by counting a number of turns, what time is taken up by one revolution of the body P: then taking off the body P and the weight M, let it be examined what smaller weight will make the arm GH revolve in the same time as when P was fixed to it: this smaller weight being taken from M, the remainder is obviously equal in effort to the resistance of the revolving body P; and this remainder being reduced in the ratio of the length of the arm to the semidiameter of the barrel, will then become equal to the absolute quantity of the resistance. And as the time of one revolution is known, and consequently the velocity of the revolving body, there is hereby discovered the absolute quantity of the resistance to the given body P moving with a given degree of celerity.

"Here, to avoid all objections, I have generally chosen, when the body P was removed, to fix in its stead a thin piece of lead of the same weight, placed horizontally: so that the weight which was to turn round the arm GH, without the body P, did also carry round this piece of lead. But mathematicians will easily allow that there was no necessity for this precaution. The diameter of the barrel BCDE, and of the silk string wound round it, was 2.06 inches. The length of the arm GH, measured from the axis to the surface of the globe P, was 49.5 inches. The body P, the globe made use of, was of pasteboard; its surface very neatly coated with marbled paper. It was not much distant from the size of a 12 lb. shot, being in diameter 4.5 inches, so that the radius of the circle described by the centre of the globe was 51.75 inches. When this globe was fixed at the end of the arm, and a weight of half a pound was hung at the end of the string at M, it was examined how soon the motion of the descending weight M, and of the revolving body P, would become equable as to sense. With this view, three revolutions being suffered to elapse, it was found that the next 10 were performed in 27 $\frac{1}{4}$ "', 20 in less than 55"', and 30 in 82 $\frac{1}{4}$ "; so that the first 10 were performed in 27 $\frac{1}{4}$ "', the second in 27 $\frac{1}{4}$ "', and the third in 27 $\frac{1}{4}$ "'.

"These experiments sufficiently evince, that even with half a pound, the smallest weight made use of,

Theory. the motion of the machine was sufficiently equable after the first three revolutions.

"The globe above mentioned being now fixed at the end of the arm, there was hung on at M a weight of $3\frac{1}{2}$ lb.; and ten revolutions being suffered to elapse, the succeeding 20 were performed in $21\frac{1}{4}$ ". Then the globe being taken off, and a thin plate of lead, equal to it in weight, placed in its room; it was found, that instead of $3\frac{1}{2}$ lb. a weight of one pound would make it revolve in less time than it did before; performing now 20 revolutions after 10 were elapsed in the space of 19".

"Hence then it follows, that from the $3\frac{1}{2}$ lb. first hung on, there is less than 1 lb. to be deducted for the resistance on the arm; and consequently the resistance on the globe itself is not less than the effort of $2\frac{1}{2}$ lb. in the situation M; and it appearing from the former measures, that the radius of the barrel is nearly $\frac{3}{5}$ of the radius of the circle described by the centre of the globe; it follows, that the absolute resistance of the globe, when it revolves 20 times in $21\frac{1}{4}$ ", (about 25 feet in a second), is not less than the 50th part of two pounds and a quarter, or of 36 ounces; and this being considerably more than half an ounce, and the globe nearly the size of a 12-pound shot, it irrefragably confirms a proposition I had formerly laid down from theory, that the resistance of the air to a 12 lb. iron shot, moving with a velocity of 25 feet in a second, is not less than half an ounce.

"The rest of the experiments were made in order to confirm another proposition, namely, that the resistance of the air within certain limits is nearly in the duplicate proportion of the velocity of the resisted body. To investigate this point, there were successively hung on at M, weights in the proportion of the numbers 1, 4, 9, 16; and letting 10 revolutions first elapse, the following observations were made on the rest.—With $\frac{7}{8}$ lb. the globe went 20 turns in $54\frac{1}{4}$ ", with 2 lb. it went 20 turns in $27\frac{1}{2}$ ", with $4\frac{1}{2}$ lb. it went 30 turns in $27\frac{1}{2}$ ", and with 8 lb. it went 40 turns in $27\frac{1}{2}$ ".—Hence it appears, that to resistances proportioned to the numbers 1, 4, 9, 16, there correspond velocities of the resisted body in the proportion of the numbers 1, 2, 3, 4; which proves, with great nicety, the proposition above mentioned.

"With regard to the rotatory motion, the first experiment was to evince, that the whirling motion of a ball combining with its progressive motion would produce such an oblique resistance and deflective power as already mentioned. For this purpose a wooden ball of $4\frac{1}{4}$ inches diameter was suspended by a double string, about eight or nine feet long. Now, by turning round the ball and twisting the double string, the ball when left to itself would have a revolving motion given it from the untwisting of the string again. And if, when the string was twisted, the ball was drawn to a considerable distance from the perpendicular, and there let go; it would at first, before it had acquired its revolving motion, vibrate steadily enough in the same vertical plane in which it first began to move: but when, by the untwisting of the string, it had acquired a sufficient degree of its whirling motion, it constantly deflected to the right or left of its first track; and sometimes proceeded so far as to have its

Theory. direction at right angles to that in which it began its motion; and this deviation was not produced by the string itself, but appeared to be entirely owing to the resistance being greater on the one part of the leading surface of the globe than the other. For the deviation continued when the string was totally untwisted; and even during the time that the string, by the motion the globe had received, was twisting the contrary way. And it was always easy to predict, before the ball was let go, which way it would deflect, only by considering on which side the whirl would be combined with the progressive motion; for on that side always the deflective power acted, as the resistance was greater here than on the side where the whirl and progressive motion were opposed to one another."

Though Mr Robins considered this experiment as an incontestable proof of the truth of his theory, he undertook to give ocular demonstration of this deflection of musket-bullets even in the short space of 100 yards.

"As all projectiles (says he), in their flight, are acted upon by the power of gravity, the deflection of a bullet from its primary direction, supposes that deflection to be upwards or downwards in a vertical plane; because, in the vertical plane, the action of gravity is compounded and entangled with the deflective force. And for this reason my experiments have been principally directed to the examination of that deflection which carries the bullet to the right or left of that plane in which it began to move. For if it appears at any time that the bullet has shifted from that vertical plane in which the motion began, this will be an incontestable proof of what we have advanced. Now, by means of screens of exceeding thin paper, placed parallel to each other at proper distances, this deflection in question may be many ways investigated. For by firing bullets which shall traverse the screens, the flight of the bullet may be traced; and it may easily appear whether they do or do not keep invariably to one vertical plane. This examination may proceed on three different principles, which I shall here separately explain.

"For first, an exactly vertical plane may be traced out upon all these screens, by which the deviation of any single bullet may be more readily investigated, only by measuring the horizontal distance of its trace from the vertical plane thus delineated; and by this means the absolute quantity of its aberration may be known. Or if the description of such a vertical plane should be esteemed a matter of difficulty and nicety, a second method may be followed; which is that of resting the piece in some fixed notch or socket, so that though the piece may have some little play to the right and left, yet all the lines in which the bullet can be directed shall intersect each other in the centre of that fixed socket: by this means, if two different shots are fired from the piece thus situated, the horizontal distances made by the two bullets on any two screens ought to be in the same proportion to each other as the respective distances of the screens from the socket in which the piece was laid. And if these horizontal distances differ from that proportion, then it is certain that one of the shots at least hath deviated from a vertical plane, although the absolute quantity of that deviation

Theory.

Theory.

viation cannot hence be assigned; because it cannot be known what part of it is to be imputed to one bullet, and what to the other.

"But if the constant and invariable position of the notch or socket in which the piece was placed, be thought too hard-an hypothesis in this very nice affair; the third method, and which is the simplest of all, requires no more than that two shot be fired through three screens without any regard to the position of the piece each time: for in this case, if the shots diverge from each other, and both keep to a vertical plane, then if the horizontal distances of their traces on the first screen be taken from the like horizontal distances on the second and third, the two remainders will be in the same proportion with the distances of the second and third screen from the first. And if they are not in this proportion, then it will be certain that one of them at least hath been deflected from the vertical plane; though here, as in the last case, the quantity of that deflection is each will not be known.

31
Remark-
able devia-
tions of
bullets to
the right
and left.

"All these three methods I have myself made use of at different times, and have ever found the success agreeable to my expectation. But the most eligible method seemed to be a compound of the two last. The apparatus was as follows.—Two screens were set up in the larger walk in the Charter-house garden; the first of them at 250 feet distance from the wall, which was to serve for a third screen; and the second 200 feet from the same wall. At 50 feet before the first screen, or at 300 feet from the wall, there was placed a large block weighing about 200lb. weight, and having fixed into it an iron bar with a socket at its extremity, in which the piece was to be laid. The piece itself was of a common length, and bored for an ounce ball. It was each time loaded with a ball of 17 to the pound, so that the windage was extremely small, and with a quarter of an ounce of good powder. The screens were made of the thinnest issue paper; and the resistance they gave to the bullet (and consequently their probability of deflecting it) was so small, that a bullet lighting one time near the extremity of one of the screens, left a fine thin fragment of it towards the edge entire, which was so very weak that it was difficult to handle it without breaking. These things thus prepared, five shots were made with the piece rested in the notch above mentioned; and the horizontal distances between the first shot, which was taken as a standard, and the four succeeding ones, both on the first and second screen and on the wall, measured in inches, were as follows:

	1st Screen.	2d Screen.	Wall.
1 to 2	1.75 R.	3.15 R.	16.7 R.
3	10 L.	15.6 L.	69.25 L.
4	1.25 L.	4.5 L.	10 L.
5	2.15 L.	5.1 L.	19.0 L.

"Here the letters R and L denote that the shot in question went either to the right or left of the first.

"If the position of the socket in which the piece was placed be supposed fixed, then the horizontal distances measured above on the first and second screen, and on the wall, ought to be in proportion to the distances of the first screen, the second screen, and the wall, from the socket. But by only looking over these numbers, it appears, that none of them are in that pro-

portion; the horizontal distance of the first and third, for instance, on the wall being above nine inches more than it should be by this analogy.

"If, without supposing the invariable position of the socket, we examine the comparative horizontal distances according to the third method described above, we shall in this case discover divarications still more extraordinary; for by the numbers set down, it appears, that the horizontal distances of the second and third shot on the two screens, and on the wall, are as under.

1st Screen.	2d Screen.	Wall.
11.75	18.75	83.95

"Here, if, according to the rule given above, the distance on the first screen be taken from the distances on the other two, the remainder will be 7, and 72.2: and these numbers, if each shot kept to a vertical plane, ought to be in the proportion of 1 to 5; that being the proportion of the distances of the second screen, and of the wall, from the first: but the last number 72.2 exceeds what it ought to be by this analogy by 37.2; so that between them there is a deviation from the vertical plane of above 37 inches, and this too in a transit of little more than 80 yards.

"But farther, to show that these irregularities do not depend on any accidental circumstance of the balls fitting or not fitting the piece, there were five shots more made with the same quantity of powder as before; but with smaller bullets, which ran much looser in the piece. And the horizontal distances being measured in inches from the trace of the first bullet to each of the succeeding ones, the numbers were as under.

	1st Screen.	2d Screen.	Wall.
1 to 2	15.6 R.	31.1 R.	94.0 R.
3	6.4 L.	12.75 L.	23.0 L.
4	4.7 R.	8.5 R.	15.5 R.
5	12.6 R.	24.0 R.	63.5 R.

"Here, again, on the supposed fixed position of the piece, the horizontal distance on the wall between the first and third will be found above 15 inches less than it should be if each kept to a vertical plane; and like irregularities, though smaller, occur in every other experiment. And if they are examined according to the third method set down above, and the horizontal distances of the third and fourth, for instance, are compared, those on the first and second screen, and on the wall, appear to be thus.

1st Screen.	2d Screen.	Wall.
11.1	21.25	38.5

"And if the horizontal distance on the first screen be taken from the other two, the remainders will be 10.15, and 27.4; where the least of them, instead of being five times the first, as it ought to be, is 4.535 short of it; so that here is a deviation of 4.5 inches.

"From all these experiments, the deflection in question seems to be incontestably evinced. But to give some farther light to this subject, I took a barrel of the same bore with that hitherto used, and bent it at about three or four inches from its muzzle to the left, the bend making an angle of three or four degrees,

with

Theory.

with the axis of the piece. This piece thus bent was fired with a loose ball, and the same quantity of powder hitherto used, the screens of the last experiment being still continued. It was natural to expect, that if this piece was pointed by the general direction of its axis, the ball would be canted to the left of that direction by the bend near its mouth. But as the bullet, in passing through that bent part would, as I conceived, be forced to roll upon the right-hand side of the barrel, and thereby its left side would turn up against the air, and would increase the resistance on that side; I predicted to the company then present, that if the axis on which the bullet whirled, did not shift its position after it was separated from the piece; then, notwithstanding the bent of the piece to the left, the bullet itself might be expected to incurvate towards the right; and this, upon trial, did most remarkably happen. For one of the bullets fired from this bent piece passed through the first screen about $1\frac{1}{4}$ inch distant from the trace of one of the shots fired from the straight piece in the last set of experiments. On the second screen, the traces of the same bullets were about three inches distant; the bullet from the crooked piece passing on both screens to the left of the other: but comparing the places of these bullets on the wall, it appeared that the bullet from the crooked piece, though it diverged from the track on the two screens, had now crossed that track, and was deflected considerably to the right of it: so that it was obvious, that though the bullet from the crooked piece might first be canted to the left, and had diverged from the track of the other bullet with which it was compared, yet by degrees it deviated again to the right, and a little beyond the second screen crossed that track from which it before diverged, and on the wall was deflected 14 inches, as I remember, on the contrary side. And this experiment is not only the most convincing proof of the reality of this deflection here contended for; but is likewise the strongest confirmation that it is brought about in the very manner and by the very circumstances which we have all along described.

"I have now only to add, that as I suspected the consideration of the revolving motion of the bullet, compounded with its progressive one, might be considered as a subject of mathematical speculation, and that the reality of any deflecting force thence arising might perhaps be denied by some computists upon the principles hitherto received of the action of fluids; I thought proper to annex a few experiments, with a view of evincing the strange deficiency of all theories of this sort hitherto established, and the unexpected and wonderful varieties which occur in these matters: The proposition which I advanced for this purpose being, That two equal surfaces meeting the air with the same degree of obliquity, may be so differently resisted, that though in one of them the resistance is less than that of a perpendicular surface meeting the same quantity of air, yet in another it shall be considerably greater.

³²
Strange
anomaly in
the resist-
ance of the
air.

"To make out this proposition, I made use of the machine already described: and having prepared a pasteboard pyramid, whose base was four inches square, and whose planes made angles of 45° with the plane of its base; and also a parallelogram four inches in

breadth, and $5\frac{1}{2}$ in length, which was equal to the surface of the pyramid, the globe P was taken off from the machine, and the pyramid was first fixed on; and 2lb. being hung at M, and the pyramid so fitted as to move with its vertex forwards, it performed 20 revolutions after the first ten were elapsed in $33''$. Then the pyramid being turned, so that its base, which was a plane of four inches square, went foremost, it now performed 20 revolutions with the same weight in $38\frac{1}{4}''$.—After this, taking off the pyramid, and fixing on the parallelogram with its longer side perpendicular to the arm, and placing its surface in an angle of 45° with the horizon by a quadrant, the parallelogram with the same weight, performed 20 revolutions in $43\frac{1}{4}''$.

Theory.

"Now here this parallelogram and the surface of the pyramid are equal to each other, and each of them met the air in an angle of 45° ; and yet one of them made 20 revolutions in $33''$, whilst the other took up $43\frac{1}{4}''$. And at the same time it appears, that a flat surface, such as the base of a pyramid, which meets the same quantity of air perpendicularly, makes 20 revolutions in $38\frac{1}{4}''$, which is the medium between the other two.

"But to give another and still more simple proof of this principle: there was taken a parallelogram four inches broad and $8\frac{1}{2}$ long. This being fixed at the end of the arm, with its long side perpendicular thereto, and being placed in an angle of 45° with the horizon, there was a weight hung on at M of $3\frac{1}{2}$ lb. with which the parallelogram made 20 revolutions in $40\frac{1}{2}''$. But after this, the position of the parallelogram was shifted, and it was placed with its shorter side perpendicular to the arm, though its surface was still inclined to an angle of 45° with the horizon; and now, instead of going slower, as might have been expected from the greater extent of part of its surface from the axis of the machine, it went round much faster: for in this last situation it made 20 revolutions in $35\frac{1}{2}''$, so that there were 5'' difference in the time of 20 revolutions; and this from no other change of circumstance than as the larger or shorter side of the oblique plane was perpendicular to the line of its direction."

In the 73d volume of the Philosophical Transactions, several experiments on this subject, but upon a larger scale, are related by Lovell Edgeworth, Esq. They confirm the truth of what Mr Robins advances, but nothing is said to explain the reason of it.

These are the principal experiments made by Mr Robins in confirmation of his theory, and which only far exceed every thing that had been formerly done, but even bid fair for advancing the art of gunnery to its *me plus ultra*. It must be observed, however, that in this art it is impossible we should ever arrive at absolute perfection; that is, it can never be expected that a gunner, by any method of calculation whatever, can be enabled to point his guns in such a manner, that the shot shall hit the mark if placed any where within its range. Aberrations, which can by no means be either foreseen or prevented, will take place from a great number of different causes. A variation in the density of the atmosphere, in the dampness of the powder, or in the figure of the shot, will cause variations in the range of the bullet, which cannot by any means be reduced to rules, and consequently

³³
Why the
art of gun-
nery cannot
become
perfect.

Theory

Theory.

must render the event of each shot very precarious. The resistance of the atmosphere simply considered, without any of those anomalies arising from its density at different times, is a problem, which, notwithstanding the labours of Mr Robins and others, hath not been completely solved: and indeed if we consider the matter in a physical light, we shall find, that without some other data than those which are yet obtained, an exact solution of it is impossible.

of consequence a ball moving through the air with any degree of velocity, ought to be as much accelerated by the action of the air behind, as it is retarded by the action of that before.—Here then it is natural to ask, If the air accelerates a moving body as much as it retards it, how comes it to make any resistance at all? yet certain it is, that this fluid doth resist, and that very considerably. To this it may be answered, that the air is always kept in some certain state or constitution by another power which rules all its motions, and it is this power undoubtedly which gives the resistance. It is not to our purpose at present to inquire what that power is; but we see that the air is often in very different states; one day, for instance, its parts are violently agitated by a storm; and another, perhaps, they are comparatively at rest in a calm. In the first case, nobody hesitates to own, that the storm is occasioned by some cause or other, which violently resists any other power that would prevent the agitation of the air. In a calm the case is the same; for it would require the same exertion of power to excite a tempest in a calm day, as to allay a tempest in a stormy one. Now it is evident, that all projectiles, by their motion, agitate the atmosphere in an unnatural manner; and consequently are resisted by that power, whatever it is, which tends to restore the equilibrium, or bring back the atmosphere to its former state.

34
The air acts as a moving power as well as a resisting one.

It is an objection that hath been made to the mathematical philosophy, and to which in many cases it is most certainly liable, that it considers the *resistance* of matter more than its capacity of giving motion to other matter. Hence, if in any case matter acts both as a resisting and a moving power, and the mathematician overlooks its effort towards motion, founding his demonstrations only upon its property of resisting, these demonstrations will certainly be false, though they should be supported by all the powers of geometry. It is to an error of this kind that we are to attribute the great differences already taken notice of between the calculations of Sir Isaac Newton, with regard to the resisting force of fluids, and what actually takes place upon trial. These calculations were made upon the supposition that the fluid through which a body moved could do nothing else but resist it; yet it is certain that the air (the fluid with which we have to do at present) proves a source of *motion*, as well as resistance, to all bodies which move in it.

If no other power besides that above mentioned acted upon projectiles, it is probable, that all resistance to their motion would be in the duplicate proportion of their velocities; and accordingly, as long as the velocity is small, we find it generally is so. But when the velocity comes to be exceedingly great, other sources of resistance arise. One of these is a subtraction of part of the moving power; which though not properly a *resistance*, or opposing another power to it, is an equivalent thereto. This subtraction arises from the following cause. The air, as we have already observed, presses upon the hinder part of the moving body by its gravity, as much as it resists the fore part of it by the same property. Nevertheless the velocity with which the air presses upon any body by means of its gravity, is limited; and it is possible that a body may change its place with so great velocity that the air hath not time to rush in upon the back part of it in order to assist its progressive motion. When this happens to be the case, there is in the first place a deficiency of the moving power equivalent to 15 pounds on every square inch of surface; at the same time that there is a positive resistance of as much more on the fore part, owing to the gravity of the atmosphere, which must be overcome before the body can move forward.

Fig 5.

To understand this matter fully, let ABC (fig. 5.) represent a crooked tube made of any solid matter, and *a, b*, two pistons which exactly fill the cavity. If the space between these pistons is full of air, it is plain they cannot come into contact with each other on account of the elasticity of the included air, but will remain at some certain distance as represented in the figure. If the piston *b* is drawn up, the air which presses in the direction C *b* acts as a resisting power, and the piston will not be drawn up with such ease as if the whole was *in vacuo*. But though the column of air pressing in the direction C *b* acts as a resisting power on the piston *b*, the column pressing in the direction A *a* will act as a moving power upon the piston *a*. It is therefore plain, that if *b* is moved upwards till it comes to the place marked *d*, the other will descend to that marked *c*. Now, if we suppose the piston *a* to be removed, it is plain, that when *b* is pulled upwards to *d*, the air descending through the leg A *a* CB will press on the under side of the piston *b*, as strongly as it would have done upon the upper side of the piston *a*, had it been present. Therefore, though the air passing down through the leg CB resists the motion of the piston *b* when drawn upwards, the air pressing down through the leg AB forwards it as much; and accordingly the piston *b* may be drawn up or pushed down at pleasure, and with very little trouble. But if the orifice at A is stopped, so that the air can only exert its resisting power on the piston *b*, it will require a considerable degree of strength to move the piston from *b* to *d*.

This deficiency of moving power, and increase of resistance, do not only take place when the body moves with a very great degree of velocity, but in all motions whatever. It is not in all cases perceptible, because the velocity with which the body moves, frequently bears but a very small proportion to the velocity with which the air presses in behind it. Thus, supposing the velocity with which the air rushes into a vacuum to be 1200 feet in a second, if a body moves with a velocity of 40, or 50 feet in a second, the force with which the air presses on the back part is but $\frac{1}{3}$ of the utmost less than that which resists on the fore part of it,

If now we suppose the tube to be entirely removed (which indeed answers no other purpose than to render the action of the air more evident), it is plain, that if the piston is moved either up or down, or in any other direction we can imagine, the air presses as much upon the back part of it as it resists it on the fore part; and

Theory.

which will not be perceptible: but if, as in the case of bullets, the velocity of the projectile comes to have a considerable proportion to the velocity wherewith the air rushes in behind it; then a very perceptible and otherwise unaccountable resistance is observed, as we have seen in the experiments already related by Mr Robins. Thus, if the air presses in with a velocity of 1200 feet in a second, if the body changes its place with a velocity of 600 feet in the same time, there is a resistance of 15 pounds on the fore part, and a pressure of only $7\frac{1}{2}$ on the back part. The resistance therefore not only overcomes the moving power of the air by $7\frac{1}{2}$ pounds, but there is a deficiency of ether $7\frac{1}{2}$ pounds owing to the want of half the pressure of the atmosphere on the back part, and thus the whole loss of the moving power is equivalent to 15 pounds; and hence the exceeding great increase of resistance observed by Mr Robins beyond what it ought to be according to the common computations.—The velocity with which the air rushes into a vacuum is therefore a desideratum in gunnery. Mr Robins supposes that it is the same with the velocity of sound; and that when a bullet moves with a velocity greater than that of 1200 feet in a second, it leaves a perfect vacuum behind it. Hence he accounts for the great increase of resistance to bullets moving with such velocities; but as he doth not take notice of the loss of the air's moving power, the anomalies of all lesser velocities are inexplicable on his principles. Nay, he even tells us, that Sir Isaac Newton's rule for computing resistances may be applied in all velocities less than 1100 or 1200 feet in a second, though this is expressly contradicted by his own experiments mentioned N^o 23.

43
It results by
its elasti-
city as well
as gravity.

Though for these reasons it is evident how great difficulties must occur in attempting to calculate the resistance of the air to military projectiles, we have not yet even discovered all the sources of resistance to these bodies when moving with immense velocities. Another power by which they are opposed (and which at last becomes greater than any of those hitherto mentioned) is the air's elasticity. This, however, will not begin to show itself in the way of resistance till the velocity of the moving body becomes considerably greater than that by which the air presses into a vacuum. Having therefore first ascertained this velocity, which we shall suppose to be 1200 feet in a second, it is plain, that if a body moves with a velocity of 1800 feet in a second, it must compress the air before it; because the fluid hath neither time to expand itself in order to fill the vacuum left behind the moving body, nor to rush in by its gravity. This compression it will resist by its elastic power, which thus becomes a new source of resistance, increasing, without any limit, in proportion to the velocity of the moving body. If now we suppose the moving body to set out with a velocity of 2400 feet in a second, it is plain, that there is not only a vacuum left behind the body, but the air before it is compressed into half its natural space. The loss of motion in the projectile therefore is now very considerable. It first loses 15 pounds on every square inch of surface on account of the deficiency of the moving power of the air behind it; then it loses 15 pounds more on account of the resistance of the air before it; again it loses 15 pounds on account of the elasticity of the compressed air; and lastly another 15 pounds on ac-

count of the vacuum behind, which takes off the weight of the atmosphere, that would have been equivalent to one half of the elasticity of the air before it. The whole resistance therefore upon every square inch of surface moving with this velocity is 60 pounds, besides that which arises from the power tending to preserve the general state of the atmosphere, and which increases in the duplicate proportion of the velocity as already mentioned. If the body is supposed to move with a velocity of 4800 feet in a second, the resistance from the air's elasticity will then be quadrupled, or amount to 60 pounds on the square inch of surface; which added to the other causes, produces a resistance of 105 pounds upon the square inch; and thus would the resistance from the elasticity of the air go on continually increasing, till at last the motion of the projectile would be as effectually stopped as if it was fired against a wall. This obstacle therefore we are to consider as really insuperable by any art whatever, and therefore it is not advisable to use larger charges of powder than what will project the shot with a velocity of 1200 feet in a second. To this velocity the elasticity of the air will not make great resistance, if indeed it makes any at all: for though Mr Robins hath conjectured that air rushes into a vacuum with the velocity of sound, or between 11 and 1200 feet in a second; yet we have no decisive proof of the truth of this supposition. At this velocity indeed, according to Mr Robins, a very sudden increase of resistance takes place: but this is denied by Mr Glenie*, who supposes that the resistance proceeds gradually; and indeed it seems to be pretty obvious, that the resistance cannot very suddenly increase, if the velocity is only increased in a small degree. Yet it is certain, that the swiftest motions with which cannon-balls can be projected are very soon reduced to this standard; for Mr Robins acquaints us, that "a 24-pound shot, when discharged with a velocity of 2000 feet in a second, will be reduced to that of 1200 feet in a second in a flight of little more than 500 yards."

* Hist. of
Gunnery.
p. 48. 5.

In the 71st volume of the Philosophical Transactions, Count Rumford has proposed a new method of determining the velocities of bullets, by measuring the force of the recoil of the piece. As in all cases action and re-action are supposed to be equal to one another, it appears that the momentum of a gun, or the force of its recoil backwards, must always be equivalent to the force of its charge: that is, the velocity with which the gun recoils, multiplied into its weight, is equal to the velocity of the bullet multiplied into its weight; for every particle of matter, whether solid or fluid, that issues out of the mouth of a piece, must be impelled by the action of some power, which power must re-act with equal force against the bottom of the bore.—Even the fine invisible elastic fluid that is generated from the powder in its inflammation, cannot put itself in motion without re-acting against the gun at the same time. Thus we see pieces, when they are fired with powder alone, recoil as well as when their charges are made to impel a weight of shot, though the recoil is not in the same degree in both cases. It is easy to determine the velocity of the recoil in any given case, by suspending the gun in an horizontal position by two pendulous rods, and measuring the arc of its ascent by means of a ribbon, as mentioned under

Theory.

Theory. the article GUNPOWDER; and this will give the momentum of the gun, its weight being known, and consequently the momentum of its charge. But in order to determine the velocity of the bullet from the momentum of the recoil, it will be necessary to know how much the weight and velocity of the elastic fluid contributes to it.

“That part of the recoil which arises from the expansion of the fluid is always very nearly the same, whether the powder is fired alone, or whether the charge is made to impel one or more bullets, as has been determined by a great variety of experiments.—If therefore a gun, suspended according to the method prescribed, is fired with any given charge of powder, but without any bullet or wad, and the recoil is observed, and if the same piece is afterwards fired with the same quantity of powder, and a bullet of a known weight, the excess of the velocity of the recoil in the latter case, over that in the former, will be proportional to the velocity of the bullet; for the difference of these velocities, multiplied into the weight of the gun, will be equal to the weight of the bullet multiplied into its velocity.—Thus, if W is put equal to the weight of the gun, U = the velocity of the bullet when fired with a given charge of powder without any bullet; V = the velocity of the recoil, when the same charge is made to impel a bullet; B = the weight of the bullet, and v = its velocity; it will be $v = \frac{V-U+W}{B}$.”

To determine how far this theory agreed with practice, an experiment was made with a charge of 165 grains of powder, without any bullet, which produced a recoil of 5.5 inches; and in another, with a bullet, the recoil was 5.6 inches; the mean of which is 5.55 inches; answering to a velocity of 1.1358 feet in a second. In five experiments with the same charge of powder, and a bullet weighing 580 grains, the mean was 14.6 inches; and the velocity of the recoil answering to the length just mentioned, is 2.9880 feet in a second: consequently $V-U$, or 2.9880—1.1358, is equal to 1.8522 feet in a second. But as the velocities of recoil are known to be as the chords of the arcs through which the barrel ascends, it is not necessary, in order to determine the velocity of the bullet, to compute the velocities V and U ; but the quantity $V-U$, or the difference of the velocities of the recoil when the given charge is fired with and without a bullet, may be computed from the value of the difference of the chords by one operation.—Thus the velocity answering to the chord 9.05 is that of 1.8522 feet in a second, is just equal to $V-U$, as was before found.

In this experiment the weight of the barrel with its carriage was just 47½ pounds, to which ½ of a pound were to be added on account of the weight of the rods by which it was suspended; which makes $W=48$ pounds, or 336,000 grains. The weight of the bullet was 580 grains; whence B is to W as 580 to 336,000; that is, as 1 to 579.31 very nearly. The value of $V-U$, answering to the experiments before mentioned, was found to be 1.8522; consequently the velocity of the bullets = v , was 1.8522 × 579.31 = 1073 feet, which differs only by 10 from 1083, the velocities found by the pendulum.

VOL. X. Part I.

The velocities of the bullets may be found from the recoil by a still more simple method; for the velocities of the recoil being as the chords measured upon the ribbon, if c is put equal to the chord of the recoil expressed in English inches, when the piece is fired with powder only, and C = the chord when the same piece is charged with a bullet: then $C-c$ will be as $V-U$;

and consequently as $\frac{V-U+W}{B}$, which measures the

velocity of the bullet, the ratio of W to B remaining the same.—If therefore we suppose a case in which $C-c$ is equal to one inch, and the velocity of the bullet is computed from that chord, the velocity in any other case, wherein $C-c$ is greater or less than one inch, will be found by multiplying the difference of the chords C and c by the velocity that answers to the difference of one inch.—The length of the parallel rods, by which the piece was suspended being .64 inches, the velocity of the recoil, = $C-c=1$ inch measured upon the ribbon, is 0.204655 parts of a foot in one second; which in this case is also the value of $V-U$: the velocity of the bullet, or v , is therefore 0.204655 × 579.31 = 118.35 feet in a second. Hence the velocity of the bullet may in all cases be found by multiplying the difference of the chords C and c by 118.35; the weight of the barrel, the length of the rods by which it is suspended, and the weight of the bullet, remaining the same; and this whatever the charge of powder made use of may be, and however it may differ in strength and goodness.

The exactness of this second method will appear from the following experiments. On firing the piece with 145 grains of powder and a bullet, the mean of three sets of experiments was 13.25, 13.15, and 13.2; and with the same charge of powder without a bullet, the recoil was 4.5, 4.3, or 4.4: $C-c$ therefore was 13.2—4.4 = 8.8 inches; and the velocity of the bullets, = 8.8 × 118.35 = 1045 feet in a second; the velocities by the pendulum coming out 10.40 feet in the same space of time.

In the far greatest number of experiments to determine the comparative accuracy of the two methods, a surprising agreement was found betwixt the last-mentioned one and that by the pendulum; but in some few the differences were very remarkable. Thus, in two where the recoil was 12.92 and 13.28, the velocity, by computation from the chords, is 1030 feet per second; but in computing by the pendulum it amounted only to 900; but in these some inaccuracy was suspected in the experiment with the pendulum, and that the computation from the recoil was most to be depended upon. In another experiment, the velocity by the recoil exceeded that by the pendulum by no less than 346 feet; the former showing 2109, and the latter only 1763 feet in a second. In two others the pendulum was also deficient, though not in such a degree. In all these it is remarkable, that where the difference was considerable, it was still in favour of the recoil. The deficiency in these experiments appears to have been somewhat embarrassing to our author. “It cannot be supposed, says he, that it arose from any imperfection in Mr Robins’s method of determining the velocities of bullets; for that method is founded upon such principles as leave no room to doubt of its accuracy;”

Y

Theory. cy; and the practical errors that occur in making the experiments, and which cannot be entirely prevented, or exactly compensated, are in general so small, that the difference in the velocities cannot be attributed to them. It is true, the effect of those errors is more likely to appear in experiments made under such circumstances as the present; for the bullet being very light (A), the arc of the ascent of the pendulum was but small; and a small mistake in measuring the chord upon the ribbon would have produced a very considerable error in computing the velocity of the bullet: Thus a difference of one-tenth of an inch, more or less, upon the ribbon, in that experiment where the difference was greatest, would have made a difference in the velocity of more than 120 feet in a second. But, independent of the pains that were taken to prevent mistakes, the striking agreement of the velocities in so many other experiments, affords abundant reason to conclude, that the errors arising from those causes were in no case very considerable.—But if both methods of determining the velocities of bullets are to be relied on, then the difference of the velocities, as determined by them in these experiments, can only be accounted for by supposing that it arose from their having been diminished by the resistance of the air in the passage of the bullets from the mouth of the piece to the pendulum; and this suspicion will be much strengthened, when we consider how great the resistance of the air is to bodies that move very swiftly in it; and that the bullets in these experiments were not only projected with great velocities, but were also very light, and consequently more liable to be retarded by the resistance on that account.

“To put the matter beyond all doubt, let us see what the resistance was that these bullets met with, and how much their velocities were diminished by it. The weight of the bullet in the most erroneous experiment was 90 grains; its diameter 0.78 of an inch; and it was projected with a velocity of 2109 feet in a second. If now a computation be made according to the law laid down by Sir Isaac Newton for compressed fluids, it will be found, that the resistance to this bullet was not less than $8\frac{1}{2}$ pounds avoirdupois, which is something more than 660 times its own weight. But Mr Robins has shewn by experiment, that the resistance of the air to bodies moving in it with very great velocity, is near three times greater than Sir Isaac has determined it; and as the velocity with which this bullet was impelled is considerably greater than any in Mr Robins's experiments, it is highly probable, that the resistance in this instance was at least 2000 times greater than the weight of the bullet.

“The distance from the mouth of the piece to the pendulum was 12 feet; but, as there is reason to think that the blast of the powder, which always follows the bullet, continues to act upon it for some sensible space of time after it is out of the bore, and, by urging it on, counterbalances, or at least counteracts in a great measure, the resistance of the air, we will suppose that the resistance does not begin, or rather that the motion of the bullet does not begin to be retarded, till it

has got to the distance of two feet from the muzzle. *Theory.* The distance, therefore, between the barrel and the pendulum, instead of 12 feet, is to be esteemed at 10 feet; and as the bullet took up about $\frac{1}{25}$ part of a second in running over that space, it must in that time have lost a velocity of about 335 feet in a second, as will appear upon making the computation; and this will very exactly account for the apparent diminution of the velocity in the experiment: for the difference of the velocities, as determined by the recoil and the pendulum = 2109—1763=346 feet in a second, is extremely near 335 feet in a second, the diminution of the velocity by the resistance as here determined.

“If the diminution of the velocities of the bullets in the two subsequent experiments be computed in like manner, it will turn out in one 65, and in the other 33, feet in a second: and making these corrections, the comparison of the two methods of ascertaining the velocities will stand thus:

Velocities by the pendulum,	1763	1317	1136
Resistance of air to be added,	335	65	33
	<hr/>	<hr/>	<hr/>
	2098	1382	1169
Velocity by the recoil,	2109	1430	1288
	<hr/>	<hr/>	<hr/>
Difference after correction,	+11	+48	+119

“It appears, therefore, that notwithstanding these corrections, the velocities as determined by the pendulum, particularly in the last, were considerably deficient. But the manifest irregularity of the velocities in those instances, affords abundant reason to conclude, that it must have arisen from some accidental cause, and therefore that little dependence is to be put upon the result of those experiments. I cannot take upon me to determine positively what the cause was which produced this irregularity, but I strongly suspect that it arose from the breaking of the bullets in the barrel by the force of the explosion: for these bullets, as has already been mentioned, were formed of lead, inclosing lesser bullets of plaster of Paris; and I well remember to have observed at the time several small fragments of the plaster which had fallen down by the side of the pendulum. I confess I did not then pay much attention to this circumstance, as I naturally concluded that it arose from the breaking of the bullet in penetrating the target of the pendulum; and that the small pieces of plaster I saw upon the ground, had fallen out of the hole by which the bullet entered. But if the bullets were not absolutely broken in pieces in firing, yet if they were considerably bruised, and the plaster, or a part of it, were separated from the lead, such a change in the form might produce a great increase in the resistance, and even their initial velocities might be affected by it; for their form being changed from that of a globe to some other figure, they might not fit the bore; and a part of the force of the charge might be lost by the windage.—That this actually happened in the experiment last mentioned, seems very probable, as the velocity with which the bullet was projected, as it

(A) They were made of lead inclosing a nucleus of Paris plaster.

Theory. it was determined by the recoil, was considerably less in proportion in that experiment than in many others which preceded and followed it in the same set.

“As allowance has been made for the resistance of the air in these cases, it may be expected that the same should be done in all other cases: but it will probably appear, upon inquiry, that the diminution of the velocities of the bullets, on that account, was so inconsiderable, that it might safely be neglected: thus, for instance, in the experiments with an ounce of powder, when the velocity of the bullet was more than 1750 feet in a second, the diminution turns out no more than 25 or 30 feet in a second, though we suppose the full resistance to have begun so near as two feet from the mouth of the piece; and in all cases where the velocity was less, the effect of the resistance was less in a much greater proportion: and even in this instance, there is reason to think, that the diminution of the velocity, as we have determined it, is too great: for the flame of gunpowder expands with such amazing rapidity, that it is scarcely to be supposed but that it follows the bullet, and continues to act upon it more than two feet, or even four feet from the gun; and when the velocity of the bullet is less, its action upon it must be sensible at a still greater distance.”

As this method of determining the velocities of bullets by the recoil of the piece did not occur to Count Rumford till after he had finished his experiments with a pendulum, and taken down his apparatus, he had it not in his power to determine the comparative strength of the recoil without and with a bullet; and consequently the velocity with which the flame issues from the mouth of a piece. He is of opinion, however, that every thing relative to these matters may be determined with greater accuracy by the new method than by any other formerly practised; and he very justly remarks, that the method of determining the velocity by the recoil, gives it originally as the bullet sets out; while that by the pendulum shows it only after a part has been destroyed by the resistance of the air. In the course of his remarks, he criticises upon a part of Mr Robins's theory, that when bullets of the same diameter, but different weights are discharged from the same piece by the same quantity of powder, their velocities are in the sub-duplicate ratio of their weight. This theory, he observes, is manifestly defective, as being founded upon a supposition, that the action of the elastic fluid, generated from the powder, is always the same in any and every given part of the bore when the charge is the same, whatever may be the weight of the bullet; and as no allowance is made for the expenditure of force required to put the fluid itself in motion, nor for the loss of it by the vent. “It is true (says he) Dr Hutton in his experiments found this law to obtain without any great error; and possibly it may hold good with sufficient accuracy in many cases; for it sometimes happens, that a number of errors or actions, whose operations have a contrary tendency, so compensate each other, that their effects when united are not sensible. But when this is the case, if any one of the causes of error is removed, those which remain will be detected.—When any given charge is loaded with a heavy bullet, more of the powder is inflamed in any very short space of time than when the bullet is lighter, and the action of the powder ought upon that ac-

count to be greater; but a heavy bullet takes up longer time in passing through the bore than a light one; and consequently more of the elastic fluid generated from the powder escapes by the vent and by windage. It may happen that the augmentation of the force, on account of one of these circumstances, may be just able to counterbalance the diminution of it arising from the other; and if it should be found upon trial, that this is the case in general, in pieces as they are now constructed, and with all the variety of shot that are made use of in practice, it would be of great use to know the fact; but when, with Mr Robins, concluding too hastily from the result of a partial experiment, we suppose, that because the sum total of the pressure of the elastic fluid upon the bullet, during the time of its passage through the bore, happens to be the same when bullets of different weights are made use of, that therefore it is always so, our reasonings may prove very inconclusive, and lead to very dangerous errors.”

In the prosecution of his subject Count Rumford proves mathematically, as well as by actual experiment, that the theory laid down by Mr Robins in this respect is erroneous. The excess is in favour of heavy bullets, which acquire a velocity greater than they ought to do according to Mr Robins's rule; and so considerable are the errors, that in one of Count Rumford's experiments, the difference was no less than 2042 feet in a second. When the weight of the bullet was increased four times, the action of the powder was found to be nearly doubled; for in one experiment, when four bullets were discharged at once, the collective pressure was as 1; but when only a single bullet was made use of, it was no more than 0.5825; and on the whole he concludes, that the velocity of bullets is in the reciprocal sub-triplicate ratio of their weights. Our author observes also, that Mr Robins is not only mistaken in the particular just mentioned, but in his conclusions with regard to the absolute force of gunpowder compared with the pressure of the atmosphere; the latter being to the force of gunpowder as 1 to 1000 according to Mr Robins; but as 1 to 1308 according to Count Rumford.

SECT. III. *Practice of Gunnery.*

WITH regard to the practical part of gunnery, which ought to consist in directing the piece in such a manner as always to hit the object against which it is pointed, there can be no certain rules given. The following maxims are laid down by Mr Robins as of use in practice.

1. In any piece of artillery whatever, the greater the quantity of powder it is charged with, the greater will be the velocity of the bullet.
2. If two pieces of the same bore, but of different lengths, are fired with the same charge of powder, the longer will impel the bullet with a greater celerity than the shorter.
3. If two pieces of artillery different in weight, and formed of different metals, have yet their cylinders of equal bores and equal lengths; then with like charges of powder and like bullets they will each of them discharge their shot with nearly the same degree of celerity.
4. The ranges of pieces at a given elevation are no

Practice. just measures of the velocity of the shot; for the same piece fired successively at an invariable elevation, with the powder, bullet, and every other circumstance as nearly the same as possible, will yet range to very different distances.

5. The greatest part of that uncertainty in the ranges of pieces which is described in the preceding maxim, can only arise from the resistance of the air.

6. The resistance of the air acts upon projectiles in a twofold manner; for it opposes their motion, and by that means continually diminishes their celerity; and it besides diverts them from the regular track they would otherwise follow; whence arise those deviations and inflections already treated of.

7. That action of the air by which it retards the motion of projectiles, though much neglected by writers on artillery, is yet, in many instances, of an immense force; and hence the motion of these resisted bodies is totally different from what it would otherwise be.

8. This retarding force of the air acts with different degrees of violence, according as the projectile moves with a greater or less velocity; and the resistances observe this law, That to a velocity which is double another, the resistance within certain limits is fourfold; to a treble velocity, ninefold; and so on.

9. But this proportion between the resistances to two different velocities, does not hold if one of the velocities be less than that of 1200 feet in a second, and the other greater. For in that case the resistance to the greater velocity is near three times as much as it would come out by a comparison with the smaller, according to the law explained in the last maxim.

10. To the extraordinary power exerted by the resistance of the air it is owing, that when two pieces of different bores are discharged at the same elevation, the piece of the largest bore usually ranges farthest; provided they are both fired with fit bullets, and the customary allotment of powder.

11. The greatest part of military projectiles will at the time of their discharge acquire a whirling motion round their axis by rubbing against the inside of their respective pieces; and this whirling motion will cause them to strike the air very differently from what they would do had they no other than a progressive motion. By this means it will happen, that the resistance of the air will not always be directly opposed to their flight; but will frequently act in a line oblique to their course, and will thereby force them to deviate from the regular track they would otherwise describe. And this is the true cause of the irregularities described in maxim 4.

12. From the sudden trebling the quantity of the air's resistance, when the projectile moves swifter than at the rate of 1200 feet in a second (as hath been explained in maxim 9.), it follows, that whatever be the regular range of a bullet discharged with this last-mentioned velocity, that range will be but little increased how much soever the velocity of the bullet may be still farther augmented by greater charges of powder.

13. If the same piece of cannon be successively fired at an invariable elevation, but with various charges of powder, the greatest charge being the whole weight of the bullet in powder, and the least not less than the

Practice. fifth part of that weight; then if the elevation be not less than eight or ten degrees, it will be found, that some of the ranges with the least charge will exceed some of those with the greatest.

14. If two pieces of cannon of the same bore, but of different lengths, are successively fired at the same elevation with the same charge of powder; then it will frequently happen, that some of the ranges with the shorter piece will exceed some of those with the longer.

15. In distant cannonadings, the advantages arising from long pieces and large charges of powder are but of little moment.

16. In firing against troops with grape-shot, it will be found, that charges of powder much less than those generally used, are the most advantageous.

17. The principal operations in which large charges of powder appear to be more efficacious than small ones, are the ruining of parapets, the dismounting of batteries covered by stout merlings, or battering in breach; for, in all these cases, if the object be but little removed from the piece, every increase of velocity will increase the penetration of the bullet.

18. Whatever operations are to be performed by artillery, the least charges of powder with which they can be effected are always to be preferred.

19. Hence, then, the proper charge of any piece of artillery is not that allotment of powder which will communicate the greatest velocity to the bullet (as most practitioners formerly maintained); nor is it to be determined by an invariable proportion of its weight to the weight of the ball: but, on the contrary, it is such a quantity of powder as will produce the least velocity for the purpose in hand; and, instead of bearing always a fixed ratio to the weight of the ball, it must be different according to the different business which is to be performed:

20. No field-piece ought at any time to be loaded with more than $\frac{1}{3}$, or at the utmost $\frac{1}{2}$, of the weight of its bullet in powder, nor should the charge of any battering piece exceed $\frac{1}{3}$ of the weight of its bullet.

21. Although precepts very different from those we have here given have often been advanced by artilleryists, and have been said to be derived from experience; yet is that pretended experience altogether fallacious; since from our doctrine of resistance established above, it follows, that every speculation on the subject of artillery, which is only founded on the experimental ranges of bullets discharged with considerable velocities, is liable to great uncertainty.

The greatest irregularities in the motion of bullets are, as we have seen, owing to the whirling motion on their axis, acquired by the friction against the sides of the piece. The best method hitherto known of preventing these is by the use of pieces with *rifled barrels*. These pieces have the insides of their cylinders cut with a number of spiral channels: so that it is in reality a female screw, varying from the common screws only in this, that its threads or rifles are less deflected, and approach more to a right line; it being usual for the threads with which the rifled barrel is indented, to take little more than one turn in its whole length. The numbers of these threads are different in each barrel, according to the size of the piece and the fancy of the workman; and in like manner the depth

Practice. to which they are cut is not regulated by any invariable rule.

The usual method of charging these pieces is this: When the proper quantity of powder is put down, a leaden bullet is taken, a small matter larger than the bore of the piece was before the rifles were cut: and this bullet being laid on the mouth of the piece, and consequently too large to go down of itself, it is forced by a strong rammer impelled by a mallet, and by repeated blows is driven home to the powder; and the softness of the lead giving way to the violence with which the bullet is impelled, that zone of the bullet which is contiguous to the piece varies its arcular form, and takes the shape of the inside of the barrel; so that it becomes part of a male screw exactly answering to the incidents of the rifle.

In some parts of Germany and Switzerland, however, an improvement is added to this practice; especially in the larger pieces which are used for shooting at great distances. This is done by cutting a piece of very thin leather, or of thin fustian, in a circular shape, somewhat larger than the bore of the barrel. This circle being greased on one side, is laid upon the muzzle with its greasy side downwards; and the bullet being then placed upon it; is forced down the barrel with it; by which means the leather or fustian incloses the lower half of the bullet, and, by its interposition between the bullet and the rifles, prevents the lead from being cut by them. But it must be remembered, that in the barrels where this is practised, the rifles are generally shallow, and the bullet ought not to be too large.—But as both these methods of charging at the mouth take up a good deal of time, the rifled barrels which have been made in Britain are contrived to be charged at the breech, where the piece is for this purpose made larger than in any other part. The powder and bullet are put in through the side of the barrel by an opening, which, when the piece is loaded, is then filled up with a screw. By this means, when the piece is fired, the bullet is forced through the rifles, and acquires the spiral motion already described; and perhaps somewhat of this kind, says Mr Robins, though not in the manner now practised, would be of all others the most perfect method for the construction of these kinds of barrels.

From the whirling motion communicated by the rifles, it happens, that when the piece is fired, that indented zone of the bullet follows the sweep of the rifles; and thereby, besides its progressive motion, acquires a circular motion round the axis of the piece; which circular motion will be continued to the bullet, after its separation from the piece; and thus a bullet discharged from a rifled barrel is constantly made to whirl round an axis which is coincident with the line of its flight. By this whirling on its axis, the aberration of the bullet, which proves so prejudicial to all operations in gunnery, is almost totally prevented. The reason of this may be easily understood from considering the slow motion of an arrow through the air. For example, if a bent arrow, with its wings not placed in some degree in a spiral position, so as to make it revolve round its axis as it flies through the air, were shot at a mark with a true direction, it would constantly deviate from it, in consequence of being pressed to one side by the convex part opposing the

air obliquely. Let us now suppose this deflection in a flight of 100 yards to be equal to 10 yards. Now, if the same bent arrow were made to revolve round its axis once every two yards of its flight, its greatest deviation would take place when it had proceeded only one yard, or made half a revolution; since at the end of the next half revolution it would again return to the same direction it had at first; the convex side of the arrow having been once in opposite positions. In this manner it would proceed during the whole course of its flight, constantly returning to the true path at the end of every two yards; and when it reached the mark, the greatest deflection to either side that could happen would be equal to what it makes in proceeding one yard, equal to $\frac{1}{10}$ th part of the former, or 3.6 inches, a very small deflection when compared with the former one. In the same manner, a cannonball which turns not round its axis, deviates greatly from the true path, on account of the inequalities on its surface; which, although small, cause great deviations by reason of the resistance of the air, at the same time that the ball acquires a motion round its axis in some uncertain direction occasioned by the friction against its sides. But by the motion acquired from the rifles, the error is perpetually corrected in the manner just now described; and accordingly such pieces are much more to be depended on, and will do execution at a much greater distance than the other.

The reasons commonly alleged for the superiority of rifle-barrels over common ones, are, either that the inflammation of the powder is greater, by the resistance which the bullet makes by being thus forced into the barrel, and that hereby it receives a much greater impulse; or that the bullet by the compounding of its circular and revolving motions, did as it were bore the air, and thereby flew to a much greater distance than it would otherwise have done; or that by the same boring motion it made its way through all solid substances, and penetrated into them much deeper than when fired in the common manner. But Mr Robins hath proved these reasons to be altogether erroneous, by a great number of experiments made with rifle-barrelled pieces. "In these experiments (says he), I have found that the velocity of the bullet fired from a rifled barrel was usually less than that of the bullet fired from a common piece with the same proportion of powder. Indeed it is but reasonable to expect that this should be the case; for if the rifles are very deep, and the bullet is large enough to fill them up, the friction bears a very considerable proportion to the effort of the powder. And that in this case the friction is of consequence enough to have its effects observed, I have discovered by the continued use of the same barrel. For the metal of the barrel being soft, and wearing away apace, its bore by half a year's use was considerably enlarged, and consequently the depths of its rifles diminished; and then I found that the same quantity of powder would give to the bullet a velocity near a tenth part greater than what it had done at first. And as the velocity of the bullet is not increased by the use of rifled barrels, so neither is the distance to which it flies, nor the depth of its penetration into solid substances. Indeed these two last suppositions seem at first sight too chimerical to deserve a formal confutation. But I cannot help ob-

Practice.

Practice. serving, that those who have been habituated to the use of rifled pieces are very excusable in giving way to these prepossessions. For they constantly found, that with them they could fire at a mark with tolerable success, though it were placed at three or four times the distance to which the ordinary pieces were supposed to reach: And therefore, as they were ignorant of the true cause of this variety, and did not know that it arose only from preventing the deflection of the ball; it was not unnatural for them to imagine that the superiority of effect in the rifled piece was owing either to a more violent impulse at first, or to a more easy passage through the air.

"In order to confirm the foregoing theory of rifle-barrelled pieces, I made some experiments by which it might be seen whether one side of the ball discharged from them uniformly keeps foremost during the whole course. To examine this particular, I took a rifled barrel carrying a bullet of six to the pound; but instead of its leaden bullet I used a wooden one of the same size, made of a soft springy wood, which bent itself easily into the rifles without breaking. And firing the piece thus loaded against a wall at such a distance as the bullet might not be shivered by the blow, I always found, that the same surface which lay foremost in the piece continued foremost without any sensible deflection during the time of its flight. And this was easily to be observed, by examining the bullet; as both the marks of the rifles, and the part that impinged on the wall, were sufficiently apparent. Now, as these wooden bullets were but the 16th part of the weight of the leaden ones, I conclude, that if there had been any unequal resistance or defective power, its effects must have been extremely sensible upon this light body, and consequently in some of the trials I made, the surface which came foremost from the piece must have been turned round into another situation.

"But again, I took the same piece, and, loading it now with a leaden ball, I set it nearly upright, sloping it only three or four degrees from the perpendicular in the direction of the wind; and firing it in this situation, the bullet generally continued about half a minute in the air; it rising by computation to near three quarters of a mile perpendicular height. In these trials I found that the bullet commonly came to the ground to the leeward of the piece; and at such a distance from it, as nearly corresponded to the angle of its inclination, and to the effort of the wind; it usually falling not nearer to the piece than 100; nor farther from it than 150, yards. And this is a strong confirmation of the almost steady flight of this bullet for about a mile and a half: for were the same trial made with a common piece, I doubt not but the deviation would often amount to half a mile, or perhaps considerably more; though this experiment would be a very difficult one to examine, on account of the little chance there would be of discovering where the ball fell.

"It must be observed, however, that though the bullet impelled from a rifle-barrelled piece keeps for a time to its regular track with sufficient nicety; yet if its flight be so far extended that the track becomes considerably incurvated, it will then undergo considerable deflections. This, according to my experiments, arises from the angle at last made by the

axis on which the bullet turns, and the direction in which it flies; for that axis continuing nearly parallel to itself, it must necessarily diverge from the line of the flight of the bullet, when that line is bent from its original direction: and when it once happens that the bullet whirls on an axis which no longer coincides with the line of its flight, then the unequal resistance formerly described will take place, and the deflecting power hence arising will perpetually increase, as the track of the bullet, by having its range extended, becomes more and more incurvated.—This matter I have experienced in a small rifle-barrelled piece, carrying a leaden ball of near half an ounce weight. For this piece, charged with one dram of powder, ranged about 550 yards at an angle of 12 degrees with sufficient regularity; but being afterwards elevated to an angle of 24 degrees, it then ranged very irregularly, generally deviating from the line of its direction to the left, and in one case not less than 100 yards. This apparently arose from the cause above mentioned, as was confirmed from the constant deviation of the bullet to the left; for by considering how the revolving motion was continued with the progressive one; it appeared that a deviation that way was to be expected.

"The best remedy I can think of for this defect is the making use of bullets of an egg-like form instead of spherical ones. For if such a bullet hath its shorter axis made to fit the piece, and it be placed in the barrel with its smaller end downwards, then it will acquire by the rifles a rotation round its larger axis; and its centre of gravity lying nearer to its fore than its hinder part, its longer axis will be constantly forced by the resistance of the air into the line of its flight; as we see, that by the same means arrows constantly lie in the line of their direction, however that line be incurvated.

"But, besides this, there is another circumstance in the use of these pieces, which renders the flight of their bullets uncertain when fired at a considerable elevation. For I find by my experiments, that the velocity of a bullet fired with the same quantity of powder from a rifled barrel, varies much more from itself in different trials than when fired from a common piece. This, as I conceive, is owing to the great quantity of friction, and the impossibility of rendering it equal in each experiment. Indeed, if the rifles are not deeply cut, and if the bullet is nicely fitted to the piece, so as not to require a great force to drive it down, and if leather or fustian well greased is made use of between the bullet and barrel, perhaps, by a careful attention to all these particulars, great part of the inequality in the velocity of the bullet may be prevented, and the difficulty in question be in some measure obviated: but, till this be done, it cannot be doubted, that the range of the same piece, at an elevation, will vary considerably in every trial; although the charge be each time the same. And this I have myself experienced, in a number of diversified trials, with a rifle-barrelled piece loaded at the breech in the English manner. For here the rifles being indented very deep, and the bullet so large as to fill them up completely, I found, that though it flew with sufficient exactness to the distance of 400 or 500 yards; yet when it was raised to an angle of about 12 degrees (at which angle, being fired with one-fifth of its weight

³⁷ Balls from rifled pieces will at length deviate from their true course.

Practice. in powder, its medium range is nearly 1000 yards); in this case, I say, I found that its range was variable; although the greatest care was taken to prevent any inequalities in the quantity of powder, or in the manner of charging. And as, in this case, the angle was too small for the first-mentioned irregularity to produce the observed effects; they can only be imputed to the different velocities which the bullet each time received by the unequal action of the friction."

Thus we see, that it is in a manner impossible entirely to correct the aberrations arising from the resistance of the atmosphere; as even the rifle-barrelled pieces cannot be depended upon for more than one-half of their actual range at any considerable elevation. It becomes therefore a problem very difficult of solution to know, even within a very considerable distance, how far a piece will carry its ball with any probability of hitting its mark, or doing any execution. The best rules hitherto laid down on this subject are those of Mr Robins. The foundation of all his calculations is the velocity with which the bullet flies off from the mouth of the piece. Mr Robins himself had not opportunities of making many experiments on the velocities of cannon-balls, and the calculations from smaller ones cannot always be depended upon. In the 68th volume of the Phil. Trans. Mr Hutton hath recited a number of experiments made on cannon carrying balls from one to three pounds weight. His machine for discovering the velocities of these balls was the same with that of Mr Robins, only of a larger size. His charges of powder were two, four, and eight ounces; and the results of 15 experiments which seem to have been the most accurate, are as follow.

38
Mr Hutton's experiments on the velocity of cannon balls.

Velocity with two ounces.	Velocity with four ounces.	Velocity with eight ounces.
702 feet in 1"	1068 feet in 1"	1419 feet in 1"
682	1020	1352
695	948	1443
703	973	1360
725	957	1412
<u>5)3507</u>	<u>5)4966</u>	<u>5)6986</u>
Mean veloo. 701	993	1397

In another course, the mean velocities, with the same charges of powder, were 613, 873, 1162. "The mean velocities of the balls in the first course of experiments (says Mr Hutton) with two, four, and eight ounces of powder, are as the numbers 1, 1.414, and 1.993; but the subduplicate ratio of the weights (two, four, and eight) give the numbers 1, 1.414, and 2, to which the others are sufficiently near. It is obvious, however, that the greatest difference lies in the last number, which answers to the greatest velocity. It will still be a little more in defect if we make the allowance for the weights of the balls; for the mean weights of the balls with the two and four ounces is 18½ ounces, but of the eight ounces it is 18¾; diminishing therefore the number 1.993 in the reciprocal subduplicate ratio of 18½ to 18¾, it becomes 1.985, which falls short of the number 2 by .015, or the 133d part of itself. A similar defect was observed in the other course of experiments; and both are owing to three evident causes, viz. 1. The less length of cylinder through which the

ball was impelled; for with the eight-ounce charge it lay three or four inches nearer to the muzzle of the piece than with the others. 2. The greater quantity of elastic fluid which escaped in this case than in the others by the windage. This happens from its moving with a greater velocity; in consequence of which, a greater quantity escapes by the vent and windage than in smaller velocities. 3. The greater quantity of powder blown out unfired in this case than in that of the lesser velocities; for the ball which was impelled with the greater velocity, would be sooner out of the piece than the others, and the more so as it had a less length of the bore to move through; and if powder fire in time, which cannot be denied, though indeed that time is manifestly very short, a greater quantity of it must remain unfired when the ball with the greater velocity issues from the piece, than when that which has the less velocity goes out, and still the more so as the bulk of powder which was at first to be inflamed in the one case so much exceeded that in the others.

Practice.

"Let us now compare the corresponding velocities in both cases. In the one they are 701, 993, 1397; in the other, 613, 873, 1162. Now the ratio of the first two numbers, or the velocities with two ounces of powder, is that of 1 to 1.436, the ratio of the next two is that of 1 to 1.1375, and the ratio of the last is that of 1 to 1.2022. But the mean weight of the shot for two and four ounces of powder was 28¾ ounces in the first course and 18½ in this; and for eight ounces of powder it was 28¾ in the first and 18¾ in this. Taking therefore the reciprocal subduplicate ratios of these weights of shot, we obtain the ratio of 1 to 1.224 for that of the balls which were fired with 2 ounces and four ounces of powder, and the ratio of 1 to 1.241 for the balls which were fired with eight ounces. But the real ratios above found are not greatly different from these; and the variation of the actual velocities from this law of the weights of shot inclines the same way in both courses of experiments. We may now collect into one view the principal inferences that have resulted from these experiments.

1. "It is evident from them that powder fires almost instantaneously.
2. "The velocities communicated to balls or shot of the same weight with different quantities of powder, are nearly in the subduplicate ratio of these quantities; a very small variation in defect taking place when the quantities of powder become great.
3. "When shot of different weights are fired with the same quantity of powder, the velocities communicated to them are nearly in the reciprocal subduplicate ratio of their weights.
4. "Shot which are of different weights, and impelled by different quantities of powder, acquire velocities which are directly as the square roots of the quantities of powder, and inversely as the square roots of the weights of the shot nearly."

The velocities of the bullets being thus found as nearly as possible, the ranges may be found by the following rules laid down by Mr Robins.

1. "Till the velocity of the projectile surpasses Mr Robins's method of finding the ranges of shot bullets.

Practice. bout half an ounce avoirdupois on a 12 pound shot, moving with a velocity of about 25 or 26 feet in a second.

2. "If the velocity be greater than that of 1100 or 1200 feet in a second, then the absolute quantity of the resistance in these greater velocities will be near three times as great as it should be by a comparison with the smaller velocities.—Hence then it appears, that if a projectile begins to move with a velocity less than that of 1100 feet in 1", its whole motion may be supposed to be considered on the hypothesis of a resistance in the duplicate ratio of the velocity. And if it begins to move with a velocity greater than this last mentioned, yet if the first part of its motion, till its velocity be reduced to near 1100 feet in 1", be considered separately from the remaining part in which the velocity is less than 1100 feet in 1"; it is evident, that both parts may be truly assigned on the same hypothesis; only the absolute quantity of the resistance is three times greater in the first part than in the last. Wherefore, if the motion of a projectile on the hypothesis of a resistance in the duplicate ratio of the velocity be truly and generally assigned, the actual motions of resisted bodies may be thereby determined, notwithstanding the increased resistances in the great velocities. And, to avoid the division of the motion into two, I shall show how to compute the whole at one operation with little more trouble than if no such increased resistance took place.

"To avoid frequent circumlocutions, the distance to which any projectile would range in a vacuum on the horizontal plane at 45° of elevation, I shall call the potential random of that projectile; the distance to which the projectile would range *in vacuo* on the horizontal plane at any angle different from 45°, I shall call the potential range of the projectile at that angle; and the distance to which a projectile really ranges, I shall call its actual range.

"If the velocity with which a projectile begins to move is known, its potential random and its potential range at any given angle are easily determined from the common theory of projectiles*; or more generally, if either its original velocity, its potential random, or its potential range, at a given angle, are known, the other two are easily found out.

"To facilitate the computation of resisted bodies, it is necessary, in the consideration of each resisted body, to assign a certain quantity, which I shall denominate F, adapted to the resistance of that particular projectile. To find this quantity F to any projectile given, we may proceed thus: First find, from the principles already delivered, with what velocity the projectile must move, so that its resistance may be equal to its gravity. Then the height from whence a body must descend in a vacuum to acquire this velocity is the magnitude of F sought. But the concisest way of finding this quantity F to any shell or bullet is this. If it be of solid iron, multiply its diameter measured in inches by 300, the product will be the magnitude of F expressed in yards. If, instead of a solid iron bullet, it is a shell or a bullet of some other substance; then, as the specific gravity of iron is to the specific gravity of the shell or bullet given, so is the F corresponding to an iron bullet of the same diameter to the proper F for the shell or bullet given. The quantity F being thus assigned, the

necessary computation of these resisted motions may be dispatched by the three following propositions, always remembering that these propositions proceed on the hypothesis of the resistance being in the duplicate proportion of the velocity of the resisted body. How to apply this principle, when the velocity is so great as to have its resistance augmented beyond this rate, shall be shown in a corollary to be annexed to the first proposition.

Actual ranges expressed in F	Corresponding potential ranges expressed in F.	Actual ranges expressed in F	Corresponding potential ranges expressed in F.	Actual ranges expressed in F	Corresponding potential ranges expressed in F
0.01	0.0100	1.55	2.7890	3.3	13.8258
0.02	0.0201	1.6	2.9413	3.35	14.4195
0.04	0.0405	1.65	3.0994	3.4	15.0377
0.06	0.0612	1.7	3.2635	3.45	15.6814
0.08	0.0822	1.75	3.4338	3.5	16.3517
0.1	0.1034	1.8	3.6107	3.55	17.0497
0.12	0.1249	1.85	3.7944	3.6	17.7768
0.14	0.1468	1.9	3.9851	3.65	18.5341
0.15	0.1578	1.95	4.1833	3.7	19.3229
0.2	0.2140	2.	4.3890	3.75	20.1446
0.25	0.2722	2.05	4.6028	3.8	21.0006
0.3	0.3324	2.1	4.8249	3.85	21.8925
0.35	0.3947	2.15	5.0557	3.9	22.8218
0.4	0.4591	2.2	5.2955	3.95	23.7901
0.45	0.5258	2.25	5.5446	4.0	24.7991
0.5	0.5949	2.3	5.8036	4.05	25.8506
0.55	0.6664	2.35	6.0728	4.1	26.9465
0.6	0.7404	2.4	6.3526	4.15	28.0887
0.65	0.8170	2.45	6.6435	4.2	29.2792
0.7	0.8964	2.5	6.9460	4.25	30.5202
0.75	0.9787	2.55	7.2605	4.3	31.8138
0.8	1.0638	2.6	7.5875	4.35	33.1625
0.85	1.1521	2.65	7.9276	4.4	34.5686
0.9	1.2436	2.7	8.2813	4.45	36.0346
0.95	1.3383	2.75	8.6492	4.5	37.5632
1.0	1.4366	2.8	9.0319	4.55	39.1571
1.05	1.5384	2.85	9.4000	4.6	40.8193
1.1	1.6439	2.9	9.8442	4.65	42.4527
1.15	1.7534	2.95	10.2752	4.7	44.3605
1.2	1.8669	3.0	10.7237	4.75	46.2460
1.25	1.9845	3.05	11.1904	4.8	48.2127
1.3	2.1066	3.1	11.6761	4.85	50.2641
1.35	2.2332	3.15	12.1816	4.9	52.4040
1.4	2.3646	3.2	12.7078	4.95	54.6363
1.45	2.5008	3.25	13.2556	5.0	56.9653
1.5	2.6422				

"PROP. I. Given the actual range of a given shell or bullet at any small angle not exceeding 8° or 10°, to determine its potential range, and consequently its potential random and original velocity.

"SOL. Let the actual range given be divided by the F corresponding to the given projectile, and find the quote in the first column of the preceding Table: then the corresponding number in the second column multiplied into F will be the potential range sought: and thence, by the methods already explained, the potential random and the original velocity of the projectile is given.

"EXAM.

* See Projectiles.

Practice. "EXAM. An 18 pounder, the diameter of whose shot is about 5 inches, when loaded with 2lb. of powder, ranged at an elevation of $3^{\circ} 30'$ to the distance of 975 yards.

"The F corresponding to this bullet is 1500 yards; and the quote of the actual range by this number is 65; corresponding to which, in the second column, is .817; whence 817 F, or 1225 yards, is the potential range sought; and this, augmented in the ratio of the size of twice the angle of elevation to the radius, gives 20050 yards for the potential random: whence it will be found, that the velocity of this projectile was that of 984 feet in a second.

"COR. 1st. If the converse of this proposition be desired; that is, if the potential range in a small angle be given, and thence the actual range be sought; this may be solved with the same facility by the same table: for if the given potential range be divided by its correspondent F, then opposite to the quote sought in the second column, there will be found in the first column a number which multiplied into F will give the actual range required. And from hence it follows, that if the actual range be given at one angle, it may be found at every other angle not exceeding 8° or 10° .

"COR. 2d. If the actual range at a given small angle be given, and another actual range be given, to which the angle is sought; this will be determined by finding the potential ranges corresponding to the two given actual ranges; then the angle corresponding to one of these potential ranges being known, the angle corresponding to the other will be found by the common theory of projectiles.

"COR. 3d. If the potential random deduced from the actual range by this proposition exceeds 13000 yards; then the original velocity of the projectile was so great, as to be affected by the treble resistance described above; and consequently the real potential random will be greater than what is here determined. However, in this case, the true potential random may be thus nearly assigned. Take a 4th continued proportional to 13000 yards, and the potential random found by this proposition, and the 4th proportional thus found may be assumed for the true potential random sought. In like manner, when the true potential random is given greater than 13000 yards, we must take two mean

proportionals between 13000 and this random^{*}; and the first of these mean proportionals must be assumed instead of the random given, in every operation described in these propositions and their corollaries. And this method will nearly allow for the increased resistance in large velocities, the difference only amounting to a few minutes in the angle of direction of the projected body, which, provided that angle exceeds two or three degrees, is usually scarce worth attending to.

"Of this process take the following example.

"A 24 pounder fired with 12 pounds of powder, when elevated at $7^{\circ} 15'$, ranged about 2500 yards. Here the F being near 1700 yards, the quote to be sought in the first column is 147, to which the number corresponding in the second column is .2556; whence the potential range is near 4350 yards, and the potential random thence resulting 17400. But this being more than 13000, we must, to get the true po-

tential random, take a 4th continued proportional to 13000 and 17400; and this 4th proportional, which is about 31000 yards, is to be esteemed the true potential random sought; whence the velocity is nearly that of 1730 feet in a second.

"SCHOLIUM. This proposition is confined to small angles, not exceeding 8° or 10° . In all possible cases of practice, this approximation, thus limited, will not differ from the most rigorous solution by so much as what will often intervene from the variation of the density of the atmosphere in a few hours time; so that the errors of the approximation are much short of other inevitable errors, which arise from the nature of this subject.

"PROP. II. Given the actual range of a given shell or bullet, at any angle not exceeding 45° , to determine its potential range at the same angle; and thence its potential random and original velocity.

"SOL. Diminish the F corresponding to the shell or bullet given in the proportion of the radius to the cosine of $\frac{1}{2}$ of the angle of elevation. Then, by means of the preceding table, operate with this reduced F in the same manner as is prescribed in the solution of the last proposition, and the result will be the potential range sought; whence the potential random, and the original velocity, are easily determined.

"EXAM. A mortar for sea-service, charged with 30lb. of powder, has sometimes thrown its shell, of $12\frac{1}{2}$ inches diameter, and of 231lb. weight, to the distance of 2 miles, or 5450 yards. This at an elevation of 45° .

"The F to this shell, if it were solid, is 3825 yards; but as the shell is only $\frac{7}{8}$ of a solid globe, the true F is no more than 3060 yards. This, diminished in the ratio of the radius to the cosine of $\frac{1}{2}$ of the angle of elevation, becomes 2544. The quote of the potential range by this diminished F is 1.384; which sought in the first column of the preceding table gives 2.280 for the corresponding number in the second column; and this multiplied into the reduced F, produces 5800 yards for the potential range sought, which, as the angle of elevation was 45° , is also the potential random; and hence the original velocity of this shell appears to be that of about 748 feet in a second.

"COR. The converse of this proposition, that is, the determination of the actual range from the potential range given, is easily deduced from hence by means of the quote of the potential range divided by the reduced F; for this quote searched out in the second column will give a corresponding number in the first column, which multiplied into the reduced F, will be the actual range sought.

"Also, if the potential random of a projectile be given, or its actual range at a given angle of elevation; its actual range at any other angle of elevation, not greater than 45° , may hence be known. For the potential random will assign the potential range at any given angle; and thence, by the method of this corollary, the actual range may be found.

"EXAM. A fit musket-bullet fired from a piece of the standard dimensions, with $\frac{7}{8}$ of its weight in good powder, acquires a velocity of near 900 feet in a second: that is, it has a potential random of near 8400 yards. If now the actual range of this bullet at 15° was sought, we must proceed thus:

Z

* The operations directed in this corollary are best performed by the table of logarithms.

Practice.

"From the given potential random it follows, that the potential range at 15° is 4200 yards; the diameter of the bullet is $\frac{1}{4}$ of an inch; and thence, as it is of lead, its proper F is 337.5 yards, which, reduced in the ratio of the radius to the cosine of $\frac{1}{4}$ of 15° , becomes 331 yards. The quote of 4200 by this number is 12.7 nearly; which being sought in the second column, gives 3.2 nearly for the corresponding number in the first column; and this multiplied into 331 yards (the reduced F) makes 1059 yards for the actual range sought.

"EXAM. II. The same bullet, fired with its whole weight in powder, acquires a velocity of about 2100 feet in a second, to which there corresponds a potential random of about 45700 yards. But this number greatly exceeding 13000 yards, it must be reduced by the method described in the third corollary of the first proposition, when it becomes 19700 yards. If now the actual range of this bullet at 15° be required, we shall from hence find, that the potential range at 15° is 9850 yards; which, divided by the reduced F of the last example, gives for a quote 2975: and thence following the steps prescribed above, the actual range of this bullet comes out 1396 yards, exceeding the former range by no more than 337 yards; whereas the difference between the two potential ranges is above ten miles. Of such prodigious efficacy is the resistance of the air, which hath been hitherto treated as too insignificant a power to be attended to in laying down the theory of projectiles!

"SCHOL. I must here observe, that as the density of the atmosphere perpetually varies, increasing and diminishing often by $\frac{1}{10}$ part, and sometimes more, in a few hours; for that reason I have not been over rigorous in forming these rules, but have considered them as sufficiently exact when the errors of the approximation do not exceed the inequalities which would take place by a change of $\frac{1}{10}$ part in the density of the atmosphere. With this restriction, the rules of this proposition may be safely applied in all possible cases of practice. That is to say, they will exhibit the true motions of all kinds of shells and cannon-shot, as far as 45° of elevation, and of all musket bullets fired with their largest customary charges, if not elevated more than 30° . Indeed, if experiments are made with extraordinary quantities of powder, producing potential randoms greatly surpassing the usual rate; then in large angles some farther modifications may be necessary. And though, as these cases are beyond the limits of all practice, it may be thought unnecessary to consider them; yet, to enable those who are so disposed to examine these uncommon cases, I shall here insert a proposition, which will determine the actual motion of a projectile at 45° , how enormous soever its original velocity may be. But as this proposition will rather relate to speculative than practical cases, instead of supposing the actual range known, thence to assign the potential random, I shall now suppose the potential random given, and the actual range to be thence investigated.

"PROP. III. Given the potential random of a given shell or bullet; to determine its actual range at 45° .

"SOL. Divide the given potential random by the F corresponding to the shell or bullet given, and call the

quotient q , and let l be the difference between the tabular logarithms of 25 and of q , the logarithm of 10 being supposed unity; then the actual range sought is

$3.4 F + 2 l F - \frac{11}{10} F$, where the double sine of $2 l F$ is to be thus understood; that if q be less than 25, it must be $-2 l F$; if it be greater, then it must be $+2 l F$. In this solution, q may be any number not less than 3, nor more than 2500.

"COR. Computing in the manner here laid down, we shall find the relation between the potential randoms, and the actual range at 45° , within the limits of this proposition, to be as expressed in the following table.

Potential Randoms.	Actual Range at 45°
3 F	1.5 F
6 F	2.1 F
10 F	2.6 F
20 F	3.2 F
30 F	3.6 F
40 F	3.8 F
50 F	4.0 F
100 F	4.6 F
200 F	5.1 F
500 F	5.8 F
1000 F	6.4 F
2500 F	7.0 F

Whence it appears, that, when the potential random is increased from 3 F to 2500 F, the actual range is only increased from $1\frac{1}{2}$ F to 7 F; so that an increase of 2497 F in the potential random produces no greater an increase in the actual range than $5\frac{1}{2}$ F, which is not its $\frac{1}{488}$ part; and this will again be greatly diminished on account of the increased resistance, which takes place in great velocities. So extraordinary are the effects of this resistance, which we have been hitherto taught to regard as inconsiderable.

"That the justness of the approximations laid down in the 2d and 3d propositions may be easier examined; I shall conclude these computations by inserting a table of the actual ranges, at 45° , of a projectile which is resisted in the duplicate proportion of its velocity. This table is computed by methods different from those hitherto described, and is sufficiently exact to serve as a standard with which the result of our other rules may be compared. And since whatever errors occur in the application of the preceding propositions, they will be most sensible at 45° of elevation, it follows, that hereby the utmost limits of those errors may be assigned.

Potential Randoms.	Actual Range at 45°
.1 F	.0963 F
.25 F	.2282 F
.5 F	.4203 F
.75 F	.5868 F
1.0 F	.7323 F
1.25 F	.860 F
1.5 F	.978 F
1.75 F	1.083 F
2.0 F	1.179 F
2.5 F	1.349 F
3.0 F	1.495 F

Practice.	Potential	Randoms.	Actual Range at 45°
3.5 F	—	—	1.624 F
4.0 F	—	—	1.738 F
4.5 F	—	—	1.840 F
5.0 F	—	—	1.930 F
5.5 F	—	—	2.015 F
6.0 F	—	—	2.097 F
6.5 F	—	—	2.169 F
7.0 F	—	—	2.237 F
7.5 F	—	—	2.300 F
8.0 F	—	—	2.359 F
8.5 F	—	—	2.414 F
9.0 F	—	—	2.467 F
9.5 F	—	—	2.511 F
10.0 F	—	—	2.564 F
11.0 F	—	—	2.651 F
13.0 F	—	—	2.804 F
15.0 F	—	—	2.937 F
20.0 F	—	—	3.196 F
25.0 F	—	—	3.396 F
30.0 F	—	—	3.557 F
40.0 F	—	—	3.809 F
50.0 F	—	—	3.998 F

the other, Not to use any brass field-artillery, but only iron, to lessen the great burden of our ships of war, and to carry larger calibers than those of other nations of the same rate. If the weights of our guns are diminished, they will require fewer hands to manage them, and of consequence a smaller number will be exposed to danger at a time: and if we carry larger calibers, our rates will be a match for larger ships.

"The advantage of using iron guns in the field instead of brass, will be that the expences are lessened in proportion to the cost of brass to that of iron, which is as 8 to 1.

"The only objection against iron is, its pretended brittleness: but as we abound in iron that is stronger and tougher than any brass, this objection is invalid. This I can assert, having seen some that cannot be broken by any force, and will flatten like hammered iron: if then we use such iron, there can be no danger of the guns bursting in the most severe action.

"Though brass guns are not liable to burst, yet they are sooner rendered unserviceable in action than iron. For by the softness of the metal, the vent widens so soon, and they are so liable to bend at the muzzle, that it would be dangerous to fire them; as we found by experience at Belleisle, and where we were obliged to take guns from the ships to finish the siege.

"These being undeniable facts, no possible reason can be assigned against using iron guns in both sea and land service, and thereby lessen the expences of artillery so considerably as will appear by the following tables.

Lengths and Weights of Iron Ship-Guns.

OLD PIECES.			NEW PIECES.		
Calib.	Length	Weight.	Calib.	Length.	Weight.
	Ft. In.	Cwt. qrs. lb.		Ft. In.	Cwt. qrs. lb.
3	4 6	7 1 7	3	3 6	3 3 0
4	6 0	12 2 13	6	4 4	7 2 0
6	7 0	17 1 14	9	5 0	11 1 0
9	7 0	23 2 2	12	5 6	15 0 0
12	9 0	32 3 3	18	6 4	22 2 0
18	9 0	41 1 8	24	7 0	30 0 0
24	9 0	48 0 0	32	7 6	40 0 0
32	9 6	53 3 23	42	8 4	52 2 0
42	10 0	55 1 12	48	8 6	60 0 0

"Guns of this construction appear sufficiently strong from the proof of two three-pounders made for Lord Egmont, and they even may be made lighter and of equal service.

Z 2

Length

⁴⁰ Of the different parts and proportions of guns. We have now only to consider that part of practical gunnery which relates to the proportions of the different parts of cannon, the metal of which they are made, &c.

Formerly guns were made of a very great length, and were on that account extremely troublesome and unmanageable. The error here was first discovered by accident; for some cannon, having been cast by mistake two feet and a half shorter than the common standard, were found to be equally efficacious in service with the common ones, and much more manageable. This soon produced very considerable alterations in the form of the artillery throughout Europe: but in no country have greater improvements in this respect been made than in our own. For a long time brass, or rather a kind of bell-metal, was thought preferable to cast iron for making of cannon. The composition of this metal is generally kept a secret by each particular founder. The author of the Military Dictionary gives the following proportions as the most common, viz. "To 240 lb. of metal fit for casting they put 68 lb. of copper, 52 lb. of brass, and 12 lb. of tin. To 4200 lb. of metal fit for casting, the Germans put 3687 $\frac{1}{2}$ lb. of copper, 204 $\frac{1}{2}$ lb. of brass, and 307 $\frac{1}{2}$ lb. of tin. Others use 100 lb. of copper, 6 lb. of brass, and 9 lb. of tin; while some make use of 100 lb. of copper, 10 lb. of brass, and 15 lb. of tin. This composition was both found to be very expensive, and also liable to great inconveniences in the using." A few years ago, therefore, a proposal was made by Mr Muller for using iron guns of a lighter construction than the brass ones, by which he supposed that a very great saving would be made in the expence; and likewise, that the guns of the new construction would be more manageable, and even efficacious, than the old ones. "The reduction of the expence (says Mr Muller) of the very large artillery necessary for sea and land service, is to be considered under two heads: the one, To diminish the weight; and

⁴¹ Composition for guns.

⁴² Mr Muller's proposal for reducing the weight of guns.

Practice.

Practice.

Length and Weight of Battering Pieces.

OLD BRASS.			NEW IRON.		
Calib.	Length.	Weight.	Calib.	Length.	Weight.
	<i>Ft. In.</i>	<i>Cwt. qrs. lb.</i>		<i>Ft. In.</i>	<i>Cwt. qrs. lb.</i>
6	8 0	19 1 0	6	6 1	9 1 0
9	9 0	25 0 0	9	7 0	14 0 0
12	9 0	29 0 0	12	7 8	18 0 0
18	9 6	48 0 0	18	9 0	29 1 0
24	9 6	51 0 0	24	9 0	37 3 0
32	10 0	55 2 0	32	9 0	42 0 0

Total 227.

Total 151.
Diff. 72.

"That these guns are sufficiently strong, is evident from the former trial; besides, there are several 32 pounders of the same dimensions and weight now existing and serviceable; though cast in King Charles II.'s time.

N. B. These battering pieces may serve in garrisons.

"It appears from these tables, that no proportion has been observed in any guns hitherto made, in respect to their length or weight, but merely by guess.

Some Examples to show what may be saved by this Scheme.

The old Royal George carried 100 brass guns, which weighed together 218.2 tons; the ton costs 130 pounds, workmanship included.

The expence of these guns is then 28366 pounds

A set of iron guns of the same number and calibers, according to my construction, weighs 127.8 tons

The ton costs 16 pounds, and the whole set 2044.8 pounds

The Royal George carries then 90.4 tons more than is necessary, and the difference between the expence is 26321.2 pounds

That is, 12.5 times more than the new iron set costs: or 12 ships of the same rate may be fitted out at less charge.

A set of the { Old } iron guns for a { 204.4 } tons
 { New } first rate weighs { 127.8 }

The difference between the weight of the old and new is 76.6 tons

The difference between the expence is then 1225.6 pounds

A set of brass battering pieces weighs 11.36 tons

A ton costs 130 pounds, and the set 1476.8 pounds

A set of the new weighs 7.55 tons

The ton costs 16 pounds, and the set 117.8 pounds

That is, the old set costs 11 times, and 63 over, more than the new set; or 11 sets of the new could be made at less expence than one of the old.

"This table shows what may be saved in the navy; and if we add those on board sloops, the different garrisons, and the field train, with the great expence of their carriage in the field, it may be found pretty near as much more.

Num. of Guns.	Weight of Old.	Weight of New.	Differ.	Num. of Ships.	Total Difference.
100	4367 3	2556 0	1811 3	5	9058 0
90	3537 3	2001 0	1536 3	9	13827 3
80	3108 3	1821 0	1287 3	7	9014 1
74	3091 0	1840 2	1250 8	32	40016 0
70	2997 0	1796 2	1200 8	10	12005 0
64	2543 3	1305 0	1258 3	23	28485 2
60	2177 3	1185 0	992 3	30	29782 2
50	1881 1	1035 0	846 1	19	16078 3
44	1365 2	705 0	660 2	8	5284 0
40	1234 2	312 2	922 0	9	8298 0
36	963 3	450 0	513 3	7	3596 1
32	956 2	435 0	521 2	28	14602 0
28	593 2	285 0	308 2	23	7095 1
24	531 3	255 0	276 3	12	3321 0
20	421 2	191 1	230 1	15	3453 3

Difference between the weights 203918 3 0

Expences { Brass guns of two first rates 203918 15 0
 of the { Iron ditto - - - 43109 5 0

We get L. 257028 0 0

To this and other proposals for reducing the weight and expence of guns great attention has been paid; and the Carron Company in Scotland have not only greatly improved those of the old construction, but a gun of a different construction, invented by Mr Charles Gaseoigne, formerly director of that work, has been of more effectual service than any hitherto made use of.—Fig. 6. represents the form and proportions of the guns made at Carron, and which serve for those of all sizes, from one half-pounders and upwards. The proportions are measured by the diameters of the caliber, or bore of the gun, divided into 16 equal parts, as represented in the figure. The following are the names of the different parts of a cannon.

Plate CCXLVIII.
 Fig. 6.
 43
 Proportions, &c. of the guns made at Carron.

- AB, the length of the cannon.
- AE, the first reinforce.
- EF, the second reinforce.
- FB, the chase.
- HB, the muzzle.
- A o, the cascabel, or pomiglion.
- AC, the breech.
- CD, the vent-field.
- FI, the chase-girdle.
- r r, the base-ring and ogee.
- t, the vent-astragal and fillets.
- p q, the first reinforce-ring and ogee.
- VW, the second reinforce-ring and ogee.
- X, the chase-astragal and fillets.

Practice. *m*, the muzzle-astragal and fillets.
n, the muzzle mouldings.
m, the swelling of the muzzle.
A, the breech-mouldings.
TT, the trunnions.

The dotted lines along the middle of the piece show the dimensions of the caliber, and the dotted circle shows the size of the ball. Fig. 7. shows a cohorn made also at Carron, and which may be measured by the same scale.

44
Use and description of carriages.

As the breech of the cannon receives an equal impulse with the bullet from the action of the inflamed gunpowder, it thence follows, that at the moment the bullet flies off, the piece itself pushes backward with very great force. This is called the *recoil* of the cannon; and if the piece is not of a very considerable weight, it would fly upwards, or to a side, with extreme violence. If again it was firmly fastened down, so that it could not move in the least, it would be very apt to burst, on account of the extreme violence with which the powder would then act upon it. For this reason it hath been found necessary to allow the recoil to take place, and consequently all large pieces of artillery are mounted upon carriages with wheels, which allow them to recoil freely; and thus they may be fired without any danger. There are several sorts of carriages for ordnance, viz. bastard carriages, with low wheels and high wheels; sea-carriages, made in imitation of those for ship-guns; and carriages for field-pieces, of which there are two kinds. The carriages must be proportioned to the pieces mounted on them. The ordinary proportion is for the carriage to have once and a half the length of the gun, the wheels to be half the length of the piece in height. Four times the diameter or caliber gives the depth of the planks in the fore end; in the middle $3\frac{1}{2}$.

45
Description of the carronade.
 Fig. 8.

Fig. 8. shows the gun called a *carronade* invented or rather improved by Mr Gascoigne; and which, in June 1779, was by the king and council instituted a standard navy-gun, and 10 of them appointed to be added to each ship of war, from a first-rate to a sloop. Of this gun the Carron Company have published the following account.

See Carronade.

"The carronade ? is made so short, that it is worked with its carriage in the ship's port; the trunnions lying immediately over the fill of the port: it is correctly bored; and the shot being perfectly round, fills the caliber with such exactness, that the least possible of the impulse of the powder escapes, upon explosion, between the cylinder and the shot; which last also is thereby more truly directed in its flight. The bottom of the cylinder is a hemisphere, to which the end of the cartridge is not liable to stick, and in which the smallest charge of powder envelopes the shot, exhausting nearly the whole of its impelling force upon it: the trunnions are placed so as to lessen the recoil, and that the gun cannot rest against the sides of the carriage, and is balanced with the utmost facility. There are views cast upon the vent and muzzle, to point the gun quickly to an object at 250 and 500 yards distance. There is a handle *A* fixed upon the pommel-end of the gun, by which it is horizontally ranged and pointed; and there is a ring cast upon the cascabel, through which the

breechin rope is reeved, the only rope used about these guns. **Practice.**

"The carronade is mounted upon a carriage *B*, with a perfectly smooth bottom of strong plank, without trucks; instead of which there is fixed on the bottom of the carriage, perpendicular from the trunnions, a gudgeon *C* of proper strength, with an iron washer *D* and pin *E* at the lower end thereof. This gudgeon is let into a corresponding groove *F*, cut in a second carriage *G*, called a *slide-carriage*; the washer supported by the pin over-reaching the under edges of the groove *H*. This slide-carriage is made with a smooth upper surface, upon which the gun-carriage is moved, and by the gudgeon always kept in its right station to the port; the groove in the slide-carriage being of a sufficient length to allow the gun to recoil and be loaded within board. The slide-carriage, the groove included, is equally broad with the fore part of the gun-carriage, and about four times the length: the fore part of the slide-carriage is fixed by hinge-bolts *I*, to the quick-work of the ship below the port, the end lying over the fill, close to the outside plank, and the groove reaching to the fore end; the gudgeon of the gun-carriage, and consequently the trunnions of the gun, are over the fill of the port when the gun is run out; and the port is made of such breadth, with its sides bevelled off within board, that the gun and carriage may range from bow to quarter. The side-carriage is supported from the deck at the hinder end, by a wedge *K*, or step-stool; which being altered at pleasure, and the fore end turning upon the hinge bolts, the carriage can be constantly kept upon a horizontal plane, for the more easy and quick working of the gun when the ship lies along.

"The gun and carriages being in their places, the breechin rope, which must be strong and limber, is reeved through the ring on the breech, then led through an eye-bolt drove downwards, the eye standing upright upon the upper edge of each cheek of the gun-carriage; from these eye-bolts the ends of the breechin rope are seized down as usual to an eye-bolt driven into the quick-work on each side, in a line with the lower surface of the slide-carriage.

"The gun being mounted and ready for action, is loaded with one-twelfth part of the weight of its ball in service charge of powder put into a woollen cartridge, and the end tied up with a worsted yarn, and placed next to the shot; and with a single ball, well rammed home upon the powder, without a wadding between them: the gun being then run out in the port, is ranged and elevated with great facility, by means of the handle on the pommel; and, by the views, very quickly pointed.—Upon discharge, the gun attempts to kick upwards, which being prevented by the washer of the gudgeon bearing hard against the under part of the slide-carriage, the recoil takes place; and the gudgeon sliding backwards in the groove (the washer still bearing against an iron plate on the under edge of the groove), till the gun is brought up by the breechin rope, as much re-action succeeds as slackens the rope, so that the gun and carriage may be instantly turned fore and aft by the handle, and loaded again.

"This gun has many singular advantages over the others.

Practice. others of light construction.—It is so extremely light, that the smallest ships can carry almost any weight of shot (the 12 pounder weighing under 500 wt. and the other calibers in proportion), and that without being attended with the inconveniences imputed generally to light guns, since it cannot injure its carriage, or jump out of its station in the port upon recoil; and it will never heat.

“It can be easily managed and worked of all calibers, from the 12 pounders downwards with two hands, and the 18 and 24 pounders with three hands. It may be readily ranged, pointed, and discharged, twice in three minutes, which doubles the strength of the ship against an enemy of equal force. It is wrought upon a horizontal plane to windward or to leeward how much soever the ship lies along under a pressure of sail; and therefore, besides being hampered with no tackles or other ropes, except the breechin rope, it may be worked with as much ease and expedition in chace or in a gale of wind as in lying to for action.—It can be ranged from bow to quarter, so as to bring a broadside to bear in a circuit of above 10 points of the compass on each side.—It is no more expensive in ammunition than the old guns of two-thirds less weight of shot; and it requires very few hands above the complement necessary for navigating merchant-ships; and increases the strength of privateers crews, by exposing few hands at the guns, and augmenting the number at small arms.

“Though the carronade cannot, strictly speaking, throw its shot to an equal distance with a longer gun; yet, from the fitness of the shot to its cylinder, the powers of this gun will greatly surpass the expectations of such as are not intimately acquainted with the effects of the elastic force of fired powder, since, with one-twelfth part of the weight of its ball, at very small elevations, it will range its shot to triple the distance at which ships generally engage, with sufficient velocity for the greatest execution, and with all the accuracy in its direction that can be attained from guns of greater lengths.

⁴⁶
Objections
to its use
answered.

“There have been two seeming disadvantages imputed to this gun, which it does not merit, viz. the nicety of fitting the shot to the bore of the gun, and its incapacity to hold more than two shot at one charge. But as seamen have few opportunities of confirming themselves in just opinions by experiments made on shore, and cannot, in that case, be fully conversant with the subject; the following loose hints may not be inept towards removing these objections.

“It is an axiom in projectiles, That a shot cannot be impelled from a gun to any distance in a direction truly parallel to the axis of the cylinder of the piece, or what is commonly called *point blank*, arising from several well known causes: for, however just may be the cylinder, and however perfect and smooth may be the sphere of its corresponding shot, and admitting that the impulse of the powder acts through the centre of gravity of the shot, and also that the shot consequently leaves the piece *in a direction parallel to the axis of its cylinder*; yet the shot is no sooner discharged, but it becomes more or less inflected by its *gravity*, and deflected, according to its *velocity*, by the *resistance of the air and wind*.

Practice. “These irregularities are of little importance in close sea-fights, and being the effect of natural causes are common to all. Besides these, the deviation of a shot from its true direction, is further augmented by the windage between the cylinder and its shot; but the greatest uncertainty in the flight of a shot, making allowance for the action of its gravity, and the air's resistance, springs from the defects of the shot itself. Round-shot for ship-guns are seldom nicely examined; and, unless they are cast *solid and truly globular*, and free of all hollows, roughness, and other outside blemishes, and well fitted to the gun, it cannot even be discharged in the direction of the axis of the piece; to the disappointment of those that use such, and to the discredit of the gun-founder, however justly the piece is viewed, or disparted; but being impelled against the surface of the cylinder, bounds and rebounds from side to side, acquires a rotatory motion, and when cast hollow withal, and breaking within the cylinder before discharge, (which sometimes happens, especially with double charges), never fails to injure, and when often repeated may at last burst, the very best guns. Round-shot should not be taken on board a ship, without being examined as to its shape and surface, gaged for its size to the caliber of the gun, and weighed that it be not above or below the standard more than half an ounce in the pound of its respective caliber: good shot then, being of the same importance to all guns, removes the first objection.

“If the direction of the flight of a shot to its object is affected by so many seeming trivial causes, how much more uncertain must it be, when two or more shot are discharged together from one gun: for the shot next to the powder being impelled with more celerity than that immediately before it, strikes against it after discharge, and sometimes shivers itself to pieces, and never fails to change obliquely the direction of both; and this happens with round and double-headed, &c. and all double charges; and which, from their various figures, cannot reach an object at the same elevations with the round-shot; especially when these other shots are of greater weight than the round, which is often the case. However frightful a broadside with double charges may appear at sea, more confusion is created by them, and more time lost, *within board*, by the strain and excessive recoil, than real damage done *without board* by the additional charge: for upon a trial on shore, where the effect can be traced, it will be found, that, at 100 yards distance, more shot will take place within a small compass by single than by double charges; and the charges will be oftener repeated in a given time, without heating the gun: and these facts being established, remove also the second objection.”

The following account of the proof of one of these guns will perhaps serve to give a more adequate idea of the great usefulness of them, than any description:—

“On Monday, Oct. 4. 1779, there was an experiment made at Carron, before the earl of Dunmore, &c. &c. with a 68 pounder carronade, nearly of the weight of a British navy 12-pounder gun, and charged with the same quantity, (viz. 6lb.) of powder.—The carronade was mounted, on its proper carriages, into a port of the dimensions of a 74 gun ship's lower deck port; was pointed without elevation, at a centre of eight inches diameter, marked on a bulk's head of the thickness

Practice. thickness of two feet five inches solid wood, at 163 yards distance; behind which, at 168 yards, there was another bulk's head of two feet four inches thick; and behind that again, at 170 yards distance, a bank of

Practice. earth. The shot pierced the bulk's heads each time, and was buried from three to four feet into the bank, and the splinters were thrown about to a considerable distance on all sides.

1st shot struck	1 foot 7 inches below the horizontal line, and 5 feet	—	from the mark.
2d ditto ditto	2 feet	ditto,	— ditto, and 2 ditto — from ditto.
3d do. do.	through the horizontal line		and 3 do. 4 inches from do.
4th do. do.	ditto.	—	— do. and 2 do. 4 ditto from do.
5th do. do.	do.	—	— do. 2 do. 10 do. from do.
6th do. do.	2 inches below	—	— do. — 10 do. from do.
7th do. do.	touched the lower part of ditto	do.	— 7 do. from do.
8th do. do.	2 inches below	—	— do. — 10 do. from do.
9th do. do.	2 feet below	—	— do. 1 foot 9 do. from do.
10th do. do.	3 inches below	—	— do. — 3 do. from do.

The carronade was laid each time by the views without an instrument; and the shot were all to the left of the mark, owing to a small error in disparting the views; the third, fourth, and fifth shot, made one fracture, as did also the sixth, seventh, and eighth, and the sixth and eighth struck the same spot.

“The carronade was easily worked with four men, and may be readily worked and discharged on board a ship twice a-minute with six men.—With six pounds weight of powder the shot was impelled with a velocity of 1400 feet in a second.”

47
Description
of rifled
ordnance.

We have already seen of how much consequence rifle-barrels are in order to bring the art of gunnery to perfection; as they enlarge the space in which the ball will fly without any lateral deflection to three or four times its usual quantity. This improvement, however, till very lately, only took place in musket-barrels. But in the beginning of the year 1774, Dr Lind, and Captain Alexander Blair of the 69th regiment of foot, invented a species of rifled field-pieces. They are made of cast iron, and are not bored like the common pieces, but have the rifles moulded on the core, after which they are cleaned out and finished with proper instruments.

Guns of this construction, which are intended for the field, ought never to be made to carry a ball of above one or two pounds weight at most; a leaden bullet of that weight being sufficient to destroy either man or horse.—A pound gun of this construction, of good metal, such as is now made by the Carron Company, need not weigh above an hundred pounds weight, and its carriage about another hundred. It can therefore be easily transported from place to place, by a few men; and a couple of good horses may transport six of these guns and their carriages, if put into a cart.

But, for making experiments, in order to determine the resistance which bodies moving with great velocities meet with from the air, a circumstance to which these guns are particularly well adapted, or for annoying an enemy's sappers that are carrying on their approaches towards a besieged place, a larger caliber may be used.

The length of the gun being divided into seven equal parts, the length of the first reinforce AB (fig. 9.) is two of these parts; the second BC, one and $\frac{1}{2}$ of the diameter of the caliber; the chase CD, four wanting $\frac{1}{2}$ of the diameter of the caliber.

The distance from the hind part of the base-ring A

to the beginning of the bore, is one caliber and $\frac{1}{8}$ of a caliber. The trunnions TT are each a caliber in breadth, and the same in length; their centres are placed three-sevenths of the gun's length from the hind part of the base ring, in such a manner that the axis of the trunnions passes through the centre line of the bore, which prevents the gun from kicking, and breaking its carriage. The length of the cascabel is one caliber and $\frac{1}{2}$ of a caliber.

The caliber of the gun being divided into 16 equal parts;

The thickness of metal at the base-ring A from the bore, is	18.5
At the end of the first reinforce ring B	17
At the same place, for the beginning of the second reinforce	17
At the end of the second reinforce C	15
At the same place for the beginning of the chase c	13.75
At the end of the chase muzzle, the mouldings a D excluded	9
At the swelling of the muzzle b	12
At the muzzle-fillet c	9.5
At the extreme moulding D	8
Base-ring	6.5
Ogee next the base-ring d	5.5
The astragal or half round	4.75
Its fillet	1
Total astragal and fillets at the ventfield c	4
First reinforce ring B	4.5
Second reinforce ring C	3.5
Its ogee	3
Its astragal	1.5
And its fillet	1
The muzzle astragal, and fillet a	4
Breadth of the fillet at the base-ring	1
Distance of the fillet at the button from the fillet at the base ring	5
Breadth of the fillet at the button	1
Diameter of the fillet at the button	18
Distance of the centre of the button from its fillet	12
Diameter of the button E	18
Diameter of its neck	10.5

The vent should be placed about half an inch from the bottom of the chamber or bore, that the cartridge may be pricked, lest some of the bottoms of the cartridges

Fig. 9.

Practice. Tridges should be left in when the gun is sponged, a circumstance which might retard the firing till the shot be again drawn (which is no easy matter), and the gun be cleaned out. From some experiments of Colonel Desaguliers and Mr Muller, it has been imagined, that the powder never has so strong an effect as when it is fired close to the bottom of the bore; yet it is found, by the experiments of Count de la Lippe, to have the greatest effect when fired near to the middle of the charge. This he proved by firing it with tubes, introduced at a vent bored through the button and breech of the gun, of different lengths, so as to reach the different parts of the powder. In the same manner, a musket or fowling-piece is found to push more when the touch-hole is placed at some little distance from the bottom of the bore; which arises from nothing but the powder's acting with more force, by being inflamed to greater advantage; consequently, in this case, the same quantity of powder will have a greater effect, than when the touch-hole is placed at the bottom of the bore, which may be of some use in husbanding the powder.

The above dimensions are taken from some elegant one half pound guns, which were made for the prince of Asturias by the Carron Company.

The rifles make one spiral turn in the length of the bore; but go no nearer to the breech, in their full size, than two calibers; and then terminate with a gentle slope in half a caliber more, so as not to prevent the cartridge with the powder from being easily sent home to the bottom of the gun, which would otherwise constantly happen with the flannel cartridges, and even sometimes with paper ones, if not made to enter very loosely. The shape of the rifles is semicircular, their breadth being equal to the diameter, which is $\frac{1}{8}$ of a caliber, and their depth equal to the semidiameter, or $\frac{1}{16}$ of a caliber.

Fig. 10.

The bullets, fig. 10. are of lead, having six knobs cast on them to fit the rifles of the gun. Being thus made of soft metal, they do not injure the rifles; and may also save an army the trouble of carrying a great quantity of shot about with them, since a supply of lead may be had in most countries from roofs, &c. which can be cast into balls as occasion requires. Lead likewise being of greater specific gravity than cast iron, flies to a much greater distance.

Rifled ordnance of any caliber may be made to carry iron-shot for battering or for other purposes; provided holes, that are a little wider at their bottoms than at their upper parts, be cast in a zone round the ball, for receiving afterwards leaden knobs to fit the rifles of the cannon; by which means, the iron-shot will have its intended line of direction preserved, without injuring the rifles more than if the whole ball was of lead, the rotatory motion round its axis, in the line of its direction (which corrects the aberration) being communicated to it by the leaden knobs, following the spiral turn of the rifles in its progress out of the gun. It is particularly to be observed, that the balls must be made to go easily down into the piece, so that the cartridge with the powder and the bullet may be both sent home together, with a single push of the hand, without any wadding above either powder or ball; by which means, the gun is quickly loaded, and the ball flies

farther than when it is forcibly driven into the gun, as was found from many experiments. The only reason why, in common rifled muskets, the bullets are rammed in forcibly, is this, that the zone of the ball which is contiguous to the inside of the bore may have the figure of the rifles impressed upon it, in such a manner as to become part of a male screw, exactly fitting the indents of the rifle, which is not at all necessary in the present case, the figure of the rifles being originally cast upon the ball. These knobs retard the flight of the bullet in some degree; but this small disadvantage is fully made up by the ease with which the gun is loaded, its service being nearly as quick as that of a common field-piece; and the retardation and quantity of the whirling motion which is communicated to the bullet being constantly the same, it will not in the least affect the experiments made with them, in order to determine the resistance of the air.

In order to hit the mark with greater certainty than can be done in the common random method, these telescope guns are furnished with a sector, the principal parts of which are, 1. The limb, which is divided in such a manner as to show elevations to 15 or 20 degrees. The length of the radius is five inches and a half, and its nonius is so divided as to show minutes of a degree.

2. The telescope, AB, fig. 11. an achromatic refractor, is seven inches in length (such as is used on Hadley's quadrants, that are fitted for taking distances of the moon from the sun or stars, in order to obtain the longitude at sea), having cross hairs in it. 3. The parallel cylindrical bar, CD, is $\frac{1}{8}$ of an inch in diameter, having two rectangular ends EF, each half an inch square and an inch long. On one side of the end next the limb of the sector, is a mark corresponding to a similar one in the hinder cock of the gun, with which it must always coincide when placed on the gun. The length of the parallel bar, together with its ends, is seven inches. The bar is fixed to the sector by means of two hollow cylinders, G, H, which allow the sector a motion round the bar. There is a finger screw a upon the hollow cylinder G, which is slit, in order to tighten it at pleasure upon the bar. 4. The circular level I, fig. 11. and 12. for setting the plane of the sector always perpendicular when placed upon the gun, is $\frac{1}{2}$ of an inch in diameter. There is a small screw d, to adjust the level at right angles to the plane of the sector. 5. The finger screw b, for fixing the index of the sector at any particular degree of elevation proposed.

The line of collimation (that is, the line of vision cut by the intersecting point of the two cross hairs in the telescope) must be adjusted truly parallel to the bar of the sector when at 0 degrees. This is done by placing the sector so that the vertical hair may exactly cover some very distant perpendicular line. If it again covers it when the sector is inverted, by turning it half round upon the bar, which has all the while been kept steady and firm, that hair is correct; if not, correct half the error by means of the small screws, c d e, fig. 11. and 13. at the eye-end of the telescope, and the other half by moving the bar; place it again to cover the perpendicular line, and repeat the above operation till the hair covers it in both positions of the sector. Then turn the sector, till the horizontal hair cover

Practice.

48

Sector and
telescope
belonging
to this
kind of
ordnance.

Fig. 11.

Fig. 13.

ver

Practice. ver the same perpendicular line; and turning the sector half round on its bar, correct it, if wrong, in the same manner as you did the vertical hair.

N. B. Of the four small screws at the eye-end of the telescope, those at the right and left hand move whatever hair is vertical, and those at top or underneath move whatever hair is horizontal.

On the side of the gun upon the first reinforce, are cast two knobs, F, fig. 9. and 14. having their middle part distant from each other six inches, for fixing on the brass-cocks, A, fig. 14. and 15. which receive the rectangular ends of the parallel cylindrical bar of the sector, when placed on the gun.

The next adjustment is to make the parallel bar, and line of collimation of the telescope, when set at 0 degrees, parallel to the bore of the gun, and consequently to the direction of the shot. The gun being loaded, the cartridge pricked, and the gun primed, place the sector on the cocks of the gun; and having first set the sector to what elevation you judge necessary, bring the intersection of the cross hairs in the telescope upon the centre of the mark, the limb of the sector being set vertical by means of the circular level, and then take off the sector without moving the gun. Fire the gun; and if the bullet hits any where in the perpendicular line, passing through the centre of the mark, the line of collimation of the telescope and direction of the shot agree: but if it hit to the right of the mark, so much do they differ. In order to correct which, bring the gun into the same position it was in before firing, and secure it there. Then file away as much of the fore cock, on the side next the gun, as will let the intersection of the cross-hair fall somewhere on the line passing perpendicularly through the point where the shot fell; and it is then adjusted in that position, so much being filed off the side of the cock at *a*, fig. 14. and 15. as will allow the side *b* to be screwed closer, that the ends of the parallel bar may have no shake in the cocks. To correct it in the other position, and so to find the true 0 degrees of the gun, that is, to bring the line of collimation of the telescope, parallel bar, and bore of the gun, truly parallel to each other, repeat the above with the trunnions perpendicular to the horizon, the sector being turned a quarter round upon its bar, so as to bring its plane vertical. The deviation of the shot found in this way is corrected by deepening one of the cocks, so that the vertical hair of the telescope may be brought to cover the line passing perpendicularly through the point where the bullet hits; the gun being placed in the same position it was in before it was fired. This adjustment being repeated two or three times, and any error that remains being corrected, the gun is fit to be mounted on its carriage for service. It is to be observed, that this sector will fit any gun, if the cocks and rectangular ends, &c. of the parallel bar be of the above dimensions, and will be equally applicable to all such pieces whose cocks have been adjusted, as if it had been adjusted separately with each of them. And if the sector be set at any degree of elevation, and the gun moved so as to bring the intersection of the cross-hairs on the object to be fired at (the limb of the sector being vertical), the bore of the gun will have the same elevation above it, in the true direction of the shot, whatever position the carriage of the gun is standing in. A te-

VOL. X. Part I.

lescope with cross hairs, fixed to a common rifled musket, and adjusted to the direction of the shot, will make any person, with a very little practice, hit an object with more precision than the most experienced marksman.

For garrison service, or for batteries, the ship or Their ⁴⁹ carriage. garrison carriage, with two iron staples on each side to put through a couple of poles to carry these guns from place to place with more dispatch, are as proper as any. But, for the field, a carriage like that at fig. 16. where ^{Fig. 16.} the shafts push in upon taking out the iron pins *a b*, and moving the cross bar A, upon which the breech of the gun rests, as far down as the shafts were pushed in, is the properest, since the whole can then be carried like a hand-barrow, over ditches, walls, or rough ground, all which may be easily understood from the figure.

The principal advantage that will accrue from the use of rifled ordnance, is the great certainty with which any object may be hit when fired at with them, since the shot deviates but little from its intended line of direction, and the gun is capable of being brought to bear upon the object, with great exactness, by means of the telescope and cross-hairs.

The other pieces of artillery commonly made use of ⁵⁰ Mortars described. are mortars, howitzers, and royals. The mortars are a kind of short cannon of a large bore, with chambers for the powder, and are made of brass or iron. Their use is to throw hollow shells filled with powder, which falling on any building, or into the works of a fortification, burst, and with their fragments destroy every thing near them. Carcases are also thrown out of them; which are a sort of shells with five holes, filled with pitch and other materials, in order to set buildings on fire; and sometimes baskets full of stones, of the size of a man's fist, are thrown out of them upon an enemy placed in the covert-way in the time of a siege. The ingenious General Desaguliers contrived to throw bags filled with grapeshot, containing in each bag from 400 to 600 shot of different dimensions, out of mortars. The effect of these is tremendous to troops forming the line of battle, passing a defile, or landing, &c. the shot pouring down like a shower of hail on a circumference of above 300 feet.

Mortars are chiefly distinguished by the dimensions of their bore; for example, a 13-inch mortar is one the diameter of whose bore is 13 inches, &c.—The land-mortars are those used in sieges, and in battles. They are mounted on beds, and both mortar and bed are transported on block carriages. There is likewise a kind of land mortars mounted on travelling carriages, invented by Count Buckeburgh, which may be elevated to any degree; whereas all the English mortars are fixed to an angle of 45°. This custom, however, does not appear to have any foundation in reason. In a siege, shells should never be thrown with an angle of 45 degrees, excepting in one case only; that is, when the battery is so far off, that they cannot otherwise reach the works: for when shells are thrown out of the trenches into the works of a fortification, or from the town into the trenches, they should have as little elevation as possible, in order not to bury themselves, but to roll along the ground, whereby they do much more damage, and occasion a much greater con-

A a

Practice. sternation among the troops, than if they sunk into the ground. On the contrary, when shells are thrown upon magazines, or any other buildings, the mortars should be elevated as high as possible, that the shells may acquire a greater force in their fall, and consequently do more execution.

There are other kinds of mortars, called *partridge-mortars*, *hand-mortars*, and *firelock-mortars*; which last are also called *bombards*. The partridge-mortar is a common one, surrounded with 13 other little mortars bored round its circumference, in the body of the metal; the middle one is loaded with a shell, and the others with grenades. The vent of the large mortar being fired, communicates its fire to the rest; so that both the shell and grenades go off at once. Hand-mortars were frequently used before the invention of cohorns. They were fixed at the end of a staff four feet and a half long, the other end being shod with iron to stick in the ground; and while the bombardier with one hand elevated it at pleasure, he fired it with the other. The firelock-mortars, or bombards, are small mortars fixed to the end of a firelock. They are loaded as all common firelocks are; and the grenade, placed in the mortar at the end of the barrel, is discharged by a flint-lock. To prevent the recoil hurting the bombardier, the bombard rests on a kind of halberd made for that purpose.

The chamber in mortars is the place where the powder is lodged. They are of different forms, and made variously by different nations; but the cylindric seems to be preferable to any other form.

51
Howitzers
and royals.

The howitzer is a kind of mortar mounted on a field-carriage like a gun: it differs from the common mortars in having the trunnions in the middle, whereas those of the mortar are at the end. The construction of howitzers is as various and uncertain as that of mortars, excepting that the chambers are all cylindric. They are distinguished by the diameter of their bore; for instance, a 10-inch howitzer is that which has a bore of 10 inches diameter, and so of others. They were much more lately invented than mortars, and indeed are plainly derived from them.

Royals are a kind of small mortars, which carry a shell whose diameter is 5.5 inches. They are mounted on beds in the same way as other mortars.

52
Parts of a
mortar.
Fig. 17.

Fig. 17. represents a mortar; and the names of its parts are as follow:

- AB, the whole length of the mortar.
- AC, the muzzle.
- CD, chase.
- DE, reinforce.
- EF, breech,
- GH, trunnions.
- a, vent.
- b, dolphin.
- c d, vent-astragal and fillets.
- d e, breech-ring and ogee.
- f g, reinforce-ring and ogee.
- g h, reinforce-astragal and fillets.
- i k, muzzle-astragal and fillets.
- l l, muzzle-ring and ogee.
- m, muzzle-mouldings.
- n, shoulders.

Interior parts.

- o, chamber.
- p, bore.
- q, mouth.
- r, vent.

The mortar-beds are formed of very solid timber, and placed upon very strong wooden frames, fixed in such a manner that the bed may turn round. The fore part of those beds is an arc of a circle described from the centre on which the whole turns.

There are several instruments employed in the load-⁵³ Instruments used in loading cannon.

1. The lantern or ladle, which serves to carry the powder into the piece, and which consists of two parts, viz. of a wooden box, appropriated to the caliber of the piece for which it is intended, and of a caliber and a half in length with its vent; and of a piece of copper nailed to the box, at the height of a half caliber.—This lantern must have three calibers and a half in length, and two calibers in breadth, being rounded at the end to load the ordinary pieces.

2. The rammer is a round piece of wood, commonly called a *box*, fastened to a stick 12 feet long, for the pieces from 12 to 33 pounders; and 10 for the 8 and 4 pounders; which serve to drive home the powder and ball to the breech.

3. The sponge is a long staff or rammer, with a piece of sheep or lamb skin wound about its end, to serve for scouring the cannon when discharged, before it be charged with fresh powder; to prevent any spark of fire from remaining in her, which would endanger the life of him who should load her again.

4. Wad-screw consists of two points of iron turned serpent-wise, to extract the wad out of the pieces when one wants to unload them, or the dirt which had chanced to enter into it.

5. The botefeux are sticks two or three feet long, and an inch thick, split at one end, to hold an end of the match twisted round it, to fire the canon.

6. The priming iron is a pointed iron rod, to clear the touch-hole of the pieces of powder or dirt; and also to pierce the cartridge, that it may sooner take fire.

7. The primer, which must contain a pound of powder at least, to prime the pieces.

8. The quoin of mire, which are pieces of wood with a notch on the side to put the fingers on, to draw them back or push them forward when the gunner points his pieces. They are placed on the sole of the carriage.

9. Leaden plates, which are used to cover the touch-hole, when the piece is charged, lest some dirt should enter it and stop it.

Before charging the piece, it is well sponged, to clean ⁵⁴ Method of it of all filth and dirt withinside; then the proper managing weight of gunpowder is put in and rammed down; care them being taken that the powder be not bruised in ramming, which weakens its effect; it is then run over by a little quantity of paper, hay, or the like; and lastly, the ball is thrown in.

To point, level, or direct the piece, so as to play against any certain point, is done by the help of a quadrant

Practice. drant with a plummet : which quadrant consists of two branches made of brass or wood ; one about a foot long, eight lines broad, and one line in thickness ; the other four inches long, and the same thickness and breadth as the former. Between these branches is a quadrant, divided into 90 degrees, beginning from the shorter branch, and furnished with thread and plummet.

The longest branch of this instrument is placed in the cannon's mouth, and elevated or lowered till the thread cuts the degree necessary to hit the proposed object. Which done, the cannon is primed, and then set fire to. The method by the sector, however, proposed by Dr Lind, is certainly in all cases to be preferred.

A 24 pounder may very well fire 90 or 100 shots every day in summer, and 60 or 75 in winter. In case of necessity it may fire more ; and some French officers of artillery assure us, that they have caused such a piece to fire every day 150 shots in a siege.—A 16 and a 12 pounder fire a little more, because they are easier served. There have even been some occasions where 200 shots have been fired from these pieces in the space of nine hours, and 138 in the space of firing. In quick firing, tubes are made use of. They are made of tin ; and their diameter is two-tenths of an inch, being just sufficient to enter into the vent of the piece. They are about six inches long, with a cap above, and cut slanting below, in the form of a pen ; the point is strengthened with some solder, that it may pierce the cartridge without bending. Through this tube is drawn a quick-match, the cap being fitted with mealed powder moistened with spirits of wine. To prevent the mealed powder from falling out by carriage, a cap of paper or flannel steeped in spirits of wine is tied over it. To range pieces in a battery, care must be taken to reconnoitre well the ground where it is to be placed, and the avenues to it. The pieces must be armed each with two lanterns or ladles, a rammer, a sponge, and two priming-irons. The battery must also be provided with carriages and other implements, necessary to remount the pieces which the enemy should chance to dismount.

To serve expeditiously and safely a piece in a battery, it is necessary to have to each a sack of leather, large enough to contain about 20 pounds of powder to charge the lanterns or ladles, without carrying them to the magazine ; and to avoid thereby making those trains of powder in bringing back the lantern from the magazine, and the accidents which frequently happen thereby.

A battery of three pieces must have 30 gabions, because six are employed on each of the two sides or epaulments, which make 12, and nine for each of the two merlons.

There ought to be two gunners and six soldiers to each piece, and an officer of artillery.

The gunner posted on the right of the piece must take care to have always a pouch full of powder and two priming irons : his office is to prime the piece, and load it with powder. The gunner on the left fetches the powder from the little magazine, and fills the lantern or ladle which his comrade holds ; after which, he takes care that the match be very well lighted, and

Practice. ready to set fire to the piece at the first command of the officer.

There are three soldiers on the right and three on the left of the piece. The two first take care to ram and sponge the piece each on his side. The rammer and sponge are placed on the left, and the lantern or ladle on the right. After having rammed well the wad put over the powder and that put over the bullet, they then take each a handspike, which they pass between the foremost spokes of the wheel, the ends whereof will pass under the head of the carriage, to make the wheel turn round, leaning on the other end of the handspike, towards the embrasure.

It is the office of the second soldier on the right to provide wad, and to put it into the piece, as well over the powder as over the bullet ; and that of his comrade on the left to provide 50 bullets, and every time the piece is to be charged to fetch one of them and put it into the piece after the powder has been rammed. Then they both take each a handspike, which they pass under the hind part of the wheel, to push it in battery.

The officer of artillery must take care to have the piece diligently served.

In the night he must employ the gunners and soldiers, who shall relieve those who have served 24 hours, to repair the embrasures.

If there be no water near the battery, care must be taken to have a cask filled with it, in which to dip the sponges and cool the pieces every 10 or 12 rounds.

The carriage for a mortar of 12 inches diameter must be 6 feet long, the flasks 12 inches long and 10 thick. The trunnions are placed in the middle of the carriage.

The carriage of an 18 inch mortar must be 4 feet long, and the flasks 11 inches high and 6 thick.

To mount the mortars of new invention, they use carriages of cast iron.

In Germany, to mount mortars from 8 to 9 inches, and carry them into the field, and execute them horizontally as a piece of cannon, they make use of a piece of wood 8 feet 2 inches long, with a hole in the middle to lodge the body of the mortar and its trunnions as far as their half diameter, and mounted on two wheels four feet high, to which they join a vantrain proportioned to it, and made like those which serve to the carriages of cannons.

Having mounted the mortar on its carriage, the next thing is to caliber the bomb by means of a great caliber, the two branches whereof embrace the whole circumference of the bomb : these two branches are brought on a rule where the different calibers are marked, among which that of the bomb is found.

If no defect be found in the bomb, its cavity is filled, by means of a funnel, with whole gunpowder ; a little space or liberty is left, that when a fusee or wooden tube, of the figure of a truncated cone, is driven through the aperture (with a wooden mallet, not an iron one for fear of accident), and fastened with a cement made of quicklime, ashes, brick-dust, and steel-filings, worked together in a glutinous water, or of four parts of pitch, two of colophony, one of turpentine, and one of wax, the powder may not be bruised. This tube is filled with a combustible matter made of two ounces

Practice. ounces of nitre, one of sulphur, and three or more of gunpowder dust well rammed. See FUSEE.

This fusee set on fire burns slowly till it reaches the gunpowder, which goes off at once, bursting the shell to pieces with incredible violence. Special care, however, must be taken that the fusee be so proportioned as that the gunpowder do not take fire ere the shell arrives at the destined place; to prevent which, the fusee is frequently wound round with a wet clammy thread.

Batteries consist,—1. Of an epaulment to shelter the mortars from the fire of the enemy. 2. Of platforms on which the mortars are placed. 3. Of small magazines of powder. 4. Of a boyau, which leads to the great magazine. 5. Of ways which lead from the battery to the magazine of bombs. 6. Of a great ditch before the epaulment. 7. Of a berm or retraite.

The platforms for mortars of 12 inches must have 9 feet in length and 6 in breadth.—The lambourds for common mortars must be four inches thick; those of a concave chamber of 8lb. of powder, 5 inches; those of 12lb. 6 inches; those of 18lb. 7 inches or thereabouts. Their length is at discretion, provided there be enough to make the platforms 9 feet long.—The fore part of the platform will be situated at two feet distance from the epaulment of the battery.—The bombardiers, to shelter themselves in their battery, and not be seen from the town besieged, raise an epaulment of 7 feet or more high, which epaulment has no embrasures.

To serve expeditiously a mortar in battery, there are required,—five strong handspikes; a dame or rammer, of the caliber of the conic chamber, to ram the wad and the earth; a wooden knife a foot long, to place the earth round the bomb; an iron scraper two feet long, one end whereof must be four inches broad and roundwise, to clean the bore and the chamber of the mortar, and the other end made in form of a spoon to clean the little chamber; a kind of brancard to carry the bomb, a shovel, and pick-axe.

The officer who is to mind the service of the mortar must have a quadrant to give the degrees of elevation.

Five bombardiers, or others, are employed in that service; the first must take care to fetch the powder to charge the chamber of the mortar, putting his priming-iron in the touch-hole before he charges the chamber; and never going to fetch the powder before he has asked his officer at what quantity of powder he designs to charge, because more or less powder is wanted according to the distance where it is fired; the same will take care to ram the wad and earth, which another soldier puts in the chamber.

The soldier on the right will put again two shovelful of earth in the bottom of the bore, which should be likewise very well rammed down.

This done, the rammer or dame is returned into its place against the epaulment on the right of the mortar: he takes an handspike in the same place to post himself behind the carriage of the mortar, in order to help to push it into battery: having laid down his handspike, he takes out his priming-iron, and primes the touch-hole with fine powder.

The second soldier on the right and left will have by that time brought the bomb ready loaded, which must

be received into the mortar by the first soldier, and placed very strait in the bore or chase of the mortar. **Practice.**

The first on the right will furnish him with earth to put round the bomb, which he must take care to ram close with the knife given him by the second on the left.

This done, each shall take a handspike, which the two first on the right and left shall put under the pegs of retreat of the fore part, and the two behind under those of the hind part, and they together push the mortar in battery.

Afterwards the officer points or directs the mortar.

During that time the first soldier takes care to prime the touch-hole of the mortar, without ramming the powder; and the last on the right must have the match ready to set fire to the fusee of the bomb on the right, while the first is ready with his on the left to set fire to the touch-hole of the mortar, which he ought not to do till he sees the fusee well lighted.

The foremost soldiers will have their handspikes ready to raise the mortar upright as soon as it has discharged, while the hindmost on the left shall with the scraper clean the bore and chamber of the mortar.

The magazine of powder for the service of the battery must be situated 15 or 20 paces behind, and covered with boards and earth over it.—The loaded bombs are on the side of the same magazine, at five or six paces distance.

The officer who commands the service of the mortar must take care to discover as much as possible with the eye the distance of the place where he intends to throw his bomb, giving the mortar the degree of elevation according to the judgment he has formed of the distance. Having thrown the first bomb, he must diminish or increase the degrees of elevation according to the place upon which it shall fall. Several make use of tables to discover the different distances according to the differences of the elevations of the mortar, especially the degrees of the quadrant from 1 to 45: but these, from the principles already laid down, must be fallacious.

The petard is the next piece of artillery which deserves our attention; and is a kind of engine of metal, somewhat in shape of a high-crowned hat, serving to break down gates, barricades, draw-bridges, or the like works, which are intended to be surprised. It is very short, narrow at the breech and wide at the muzzle, made of copper mixed with a little brass, or of lead with tin.

The petards are not always of the same height and bigness: they are commonly 10 inches high, 7 inches of diameter a-top, and 10 inches at bottom. They weigh commonly 40, 45, and 50 pounds.

The madrier, on which the petard is placed, and where it is tied with iron circles, is of two feet for its greatest width, and of 18 inches on the sides, and no thicker than a common madrier. Under the madrier are two iron bars passed crosswise, with a hook, which serves to fix the petard.

To charge a petard 15 inches high, and 6 or 7 inches of caliber or diameter at the bore, the inside must be first very well cleaned and heated, so that the hand may bear the heat; then take the best powder that may be found, throw over it some spirit of wine, and

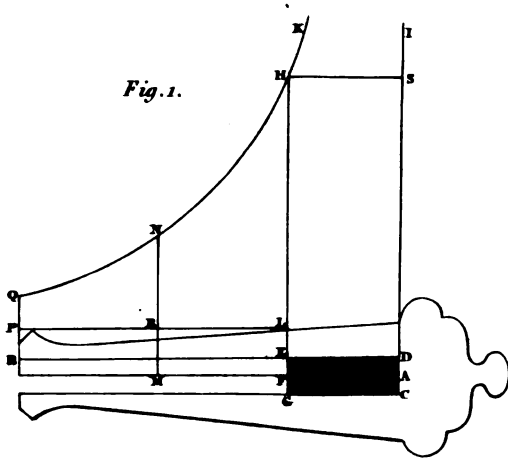

Fig. 2.



Fig. 3.

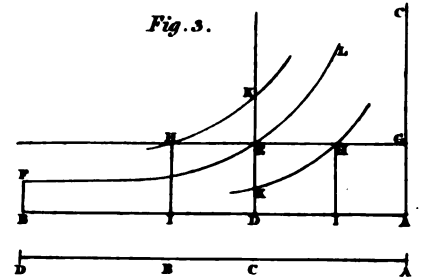

Fig. 4.

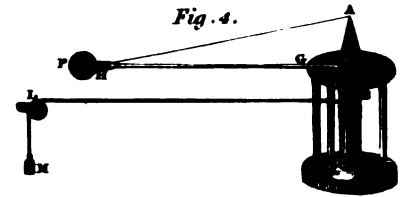

Fig. 5.

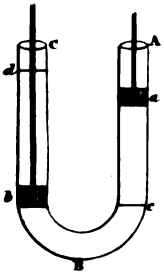

Fig. 6.

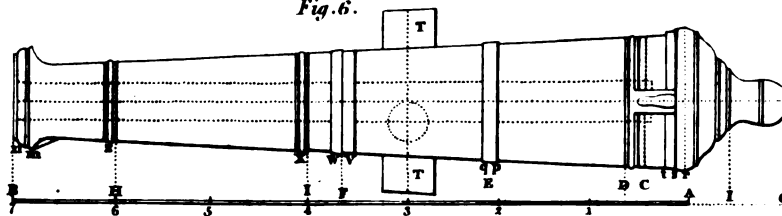

Fig. 11.

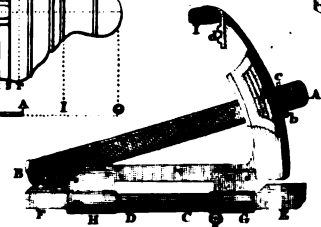

Fig. 12.



Fig. 8.

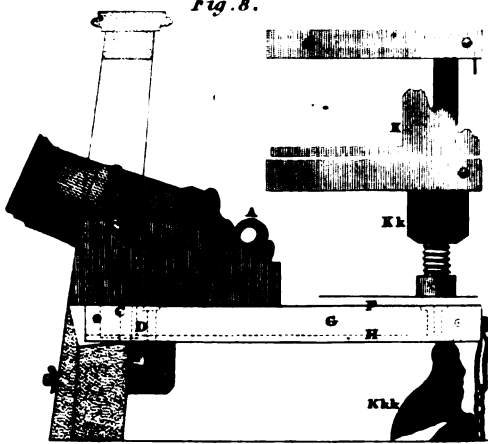

Fig. 7.

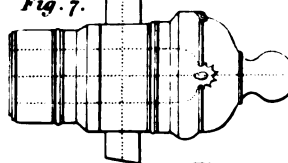

Fig. 13.



Fig. 17.

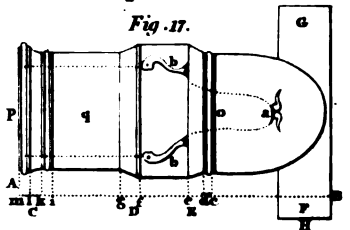

Fig. 15.

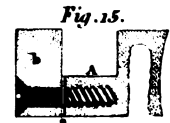

Fig. 16.

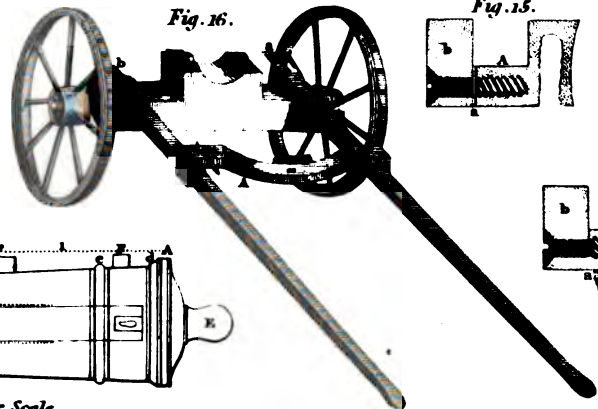

Fig. 14.

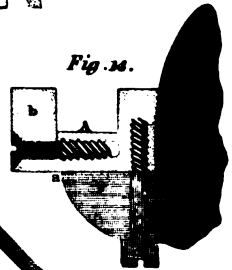

Fig. 9.

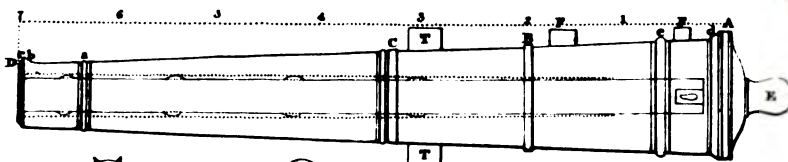

Fig. 10.



Caliber Scale.

Eng^d by Williams

GUNNERY.

PLATE CCXLIX.

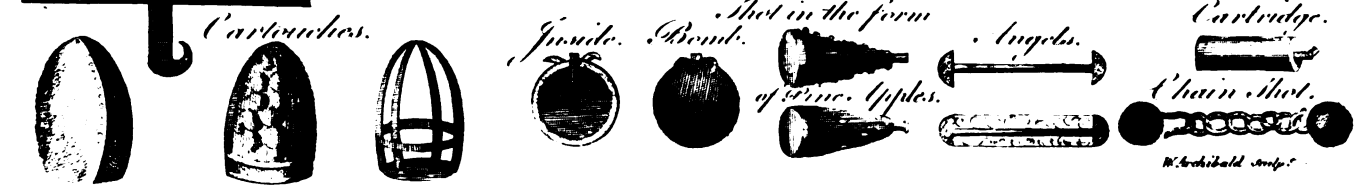
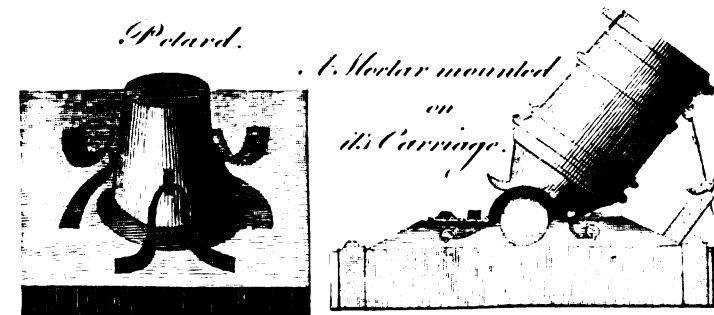
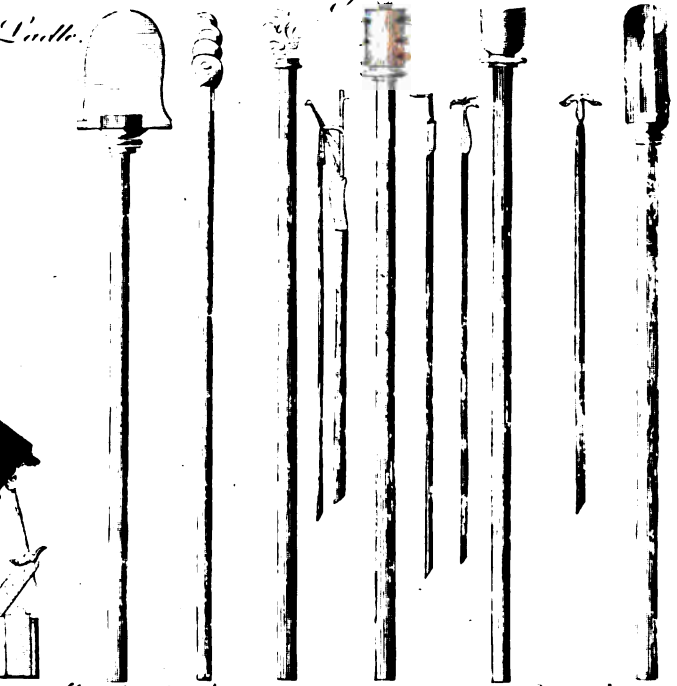
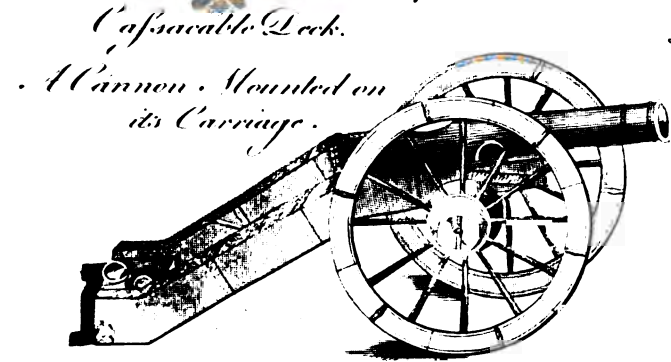
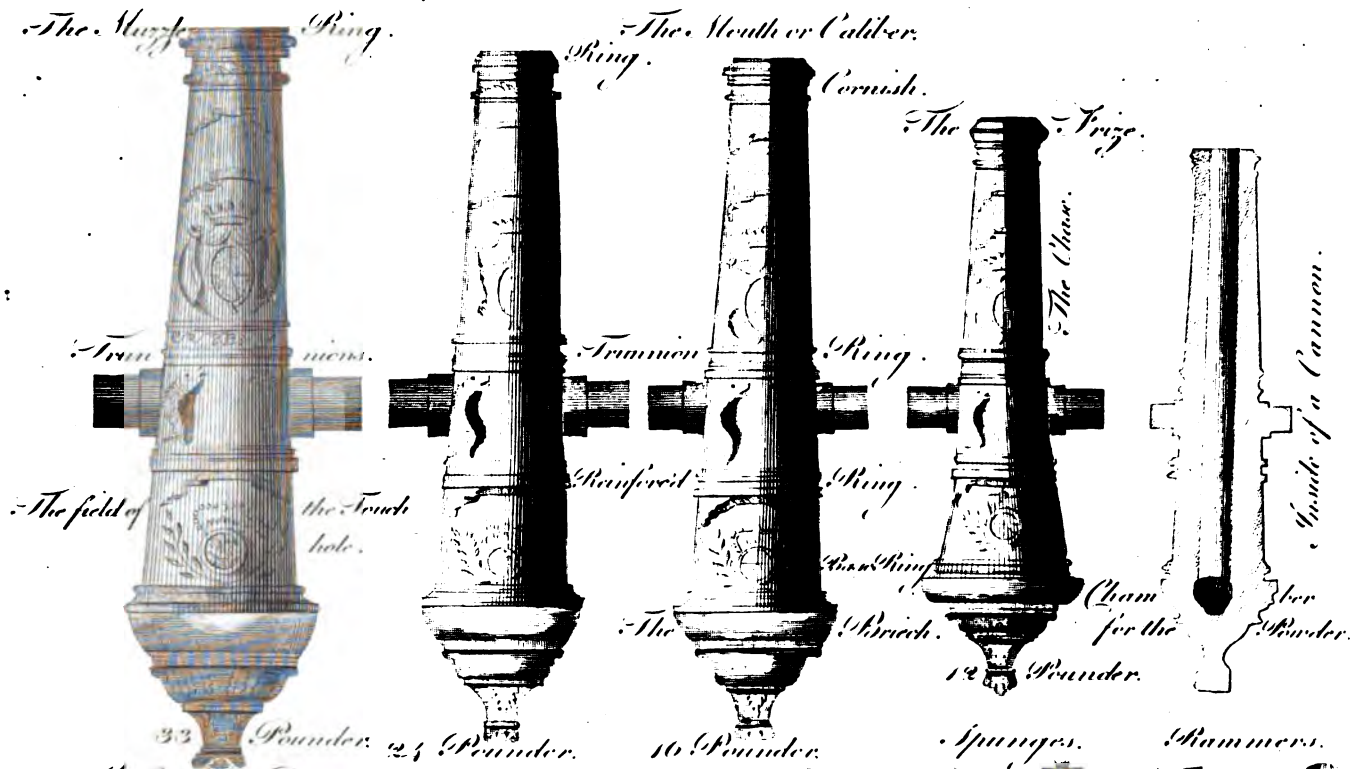

Practice. and expose it to the sun, or put it in a frying-pan; and when it is well dried, 5 lb. or 6 lb. of this powder is put into the petard, which reaches within three fingers of the mouth: the vacancies are filled with tow, and stopped with a wooden tompon; the mouth being strongly bound up with cloth tied very tight with ropes; then it is fixed in the madrier, that has a cavity cut in it to receive the mouth of the petard, and fastened down with ropes.

Some, instead of gunpowder for the charge, use one of the following compositions, viz. gunpowder seven pounds, mercury sublimate one ounce, camphor eight ounces; or gunpowder six pounds, mercury sublimate three ounces, and sulphur three; or gunpowder six, beaten glass half an ounce, and camphor three quarts.

Before any of these pieces are appropriated for service, it is necessary to have each undergo a particular trial of its soundness, which is called a *proof*, to be made by or before one authorized for the purpose, called the *proof-master*.

To make a proof of the piece, a proper place is chosen, which is to be terminated by a mount of earth very thick to receive the bullets fired against it, that none of them may run through it. The piece is laid on the ground, supported only in the middle by a block of wood. It is fired three times; the first with powder of the weight of the bullet, and the two others with $\frac{1}{4}$ of the weight; after which a little more powder is put in to singe the piece; and after this, water, which is impressed with a sponge, putting the finger on the touch-hole to discover if there be any cracks; which

done, they are examined with the cat, which is a piece of iron with three grasps, disposed in the form of a triangle, and of the caliber of the piece; then it is visited with a wax-candle, but it is of very little service in the small pieces, because if they be a little long, the smoke extinguishes it immediately. See Plate CCXLIX.

Besides the large pieces already mentioned, invented ⁵⁷ for the destruction of mankind, there are others called *small arms*, viz. muskets of ramparts, common muskets, fusils, carabines, musketoons, and pistols.

A musket, or musquet, is a fire-arm borne on the shoulder, and used in war, formerly fired by the application of a lighted match, but at present with a flint and lock. The common musket is of the caliber of 20 leaden balls to the pound, and receives balls from 22 to 24: its length is fixed to 3 feet 8 inches from the muzzle to the touch-pan.

A fusil, or fire-lock, has the same length and caliber, and serves at present instead of a musket.

A carabine is a small sort of fire-arm, shorter than a fusil, and carrying a ball of 24 in the pound, borne by the light-horse, hanging at a belt over the left shoulder. This piece is a kind of medium between the pistol and the musket; and bears a near affinity to the arquebuss, only that its bore is smaller. It was formerly made with a match-lock, but afterwards with a flint-lock.

The musketoon is of the same length of the carabine, the barrel polished, and clean within. It carries five ounces of iron, or seven and a half of lead, with an equal quantity of powder.

The barrel of a pistol is generally 14 inches long.

G U N

G U N

GUNPOWDER, a composition of nitre, sulphur, and charcoal, mixed together, and usually granulated; which easily takes fire, and, when fired, rarefies or expands with great vehemence, by means of its elastic force.

It is to this powder we owe all the action and effect of guns, ordnance, &c. so that the modern military art, fortification, &c. in a great measure depend thereon.

Invention of GUNPOWDER. See GUN.

Method of making GUNPOWDER. Dr Shaw's receipt for this purpose is as follows: Take four ounces of refined nitre, an ounce of sulphur, and six drams of small-cal: reduce these to a fine powder, and continue beating them for some time in a stone mortar with a wooden pestle, wetting the mixture between whiles with water, so as to form the whole into an uniform paste, which is reduced to grains, by passing it through a wire-sieve fit for the purpose; and in this form being carefully dried, it becomes the common gunpowder.

For greater quantities mills are usually provided, by means of which more work may be performed in one day than a man can do in a hundred.

The nitre or saltpetre is refined thus: Dissolve four pounds of rough nitre as it comes to us from the Indies, by boiling it in as much water as will commodiously suffice for that purpose: then let it shoot for two

or three days in a covered vessel of earth, with sticks laid across for the crystals to adhere to. These crystals being taken out, are drained and dried in the open air.

In order to reduce this salt to powder, they dissolve a large quantity of it in as small a portion of water as possible; then keep it constantly stirring over the fire till the water exhales, and a white dry powder is left behind.

In order to purify the sulphur employed, they dissolve it with a very gentle heat; then scum and pass it through a double strainer. If the sulphur should happen to take fire in the melting, they have an iron cover that fits on close to the melting vessel, and damps the flame. The sulphur is judged to be sufficiently refined if it melts, without yielding any fetid odour, between two hot iron plates, into a kind of red substance.

The coal for making gunpowder is either that of willow or hazel, well charged in the usual manner, and reduced to powder. And thus the ingredients are prepared for making this commodity: but as these ingredients require to be intimately mixed, and as there would be danger of their firing if beat in a dry form, the method is to keep them continually moist, either with water, urine, or a solution of sal ammoniac: they continue thus stamping them together for 24 hours; after which the mass is fit for corning and drying.

Gunpow-
der.

drying in the sun, or otherwise, so as sedulously to prevent its firing.

Different kinds of GUNPOWDER. The three ingredients of gunpowder are mixed in various proportions according as the powder is intended for muskets, great guns, or mortars, though these proportions seem not to be perfectly adjusted or settled by competent experience.

Semienowitz, for mortars, directs a hundred pounds of saltpetre, twenty-five of sulphur, and as many of charcoal; for great guns, a hundred pounds of saltpetre, fifteen pounds of sulphur, and eighteen pounds of charcoal; for muskets and pistols, a hundred pounds of saltpetre, eight pounds of sulphur, and ten pounds of charcoal. Miethius extols the proportion of one pound of saltpetre to three ounces of charcoal, and two or two and a quarter of sulphur; than which, he affirms, no gunpowder can possibly be stronger. He adds, that the usual practice of making the gunpowder weaker for mortars than guns, is without any foundation, and renders the expence needlessly much greater: for whereas to load a large mortar twenty-four pounds of common powder is required, and consequently, to load it ten times, two hundred and forty pounds, he shows, by calculation, that the same effect would be produced by one hundred and fifty pounds of the strong powder.

* *Phil.
Trans.
vol. lxxi.*

On this subject Count Rumford* observes, that almost all those who have written upon gunpowder, particularly those of the last century, have given different receipts for its composition; and he proposes it as a query, Whether these differences have not arisen from observing that some kinds of powder were better adapted to particular purposes than others, or from experiments made on purpose to ascertain the fact? "There is one circumstance (he says) that would lead us to suppose that this was the case. That kind of powder designed for mortars and great guns was weaker than that intended for small arms: for if there is any foundation for these conjectures, it is certain, that the weakest powder, or the heaviest in proportion to its elastic force, ought to be used to impel the heaviest bullets; and particularly in guns that are imperfectly formed, where the vent is large, and the windage very great. I am perfectly aware (adds he), that an objection may here be made, viz. that the elastic fluid generated from gunpowder must be supposed to have the same properties very nearly, whatever may be the proportion of its several ingredients; and that therefore the only difference there can be in powder is, that one kind may generate more of this fluid, and another less; and that when it is generated it acts in the same manner, and will alike escape, and with the same velocity, by any passage it can find. But to this I answer, that though the fluid may be the same, as it undoubtedly is, and though its density and elasticity may be the same in all cases at the instant of its generation; yet in the explosion, the elastic and unelastic parts are so mixed together, that I imagine the fluid cannot expand without taking the gross matter along with it; and the velocity with which the flame issues at the vent is to be computed from the elasticity of the fluid, and the density or weight of the fluid and gross matter taken together, and not simply from the density and elasticity of the fluid."

Gunpow-
der.

To increase the strength of powder, Dr Shaw thinks it proper to make the grains considerably large, and to have it well sifted from the small dust. We see that gunpowder, reduced to dust, has little explosive force; but when the grains are large, the flame of one grain has a ready passage to another, so that the whole parcel may thus take fire nearly at the same time, otherwise much force may be lost, or many of the grains go away as shot unfired.

In the 71st volume of the *Phil. Trans.* Count Rumford gives an account of several attempts to augment the force of gunpowder by the addition of different ingredients. The power of steam has by many been overrated to such a degree, as to be supposed capable of answering the purposes of gunpowder; but no attempts to accomplish this have ever succeeded in any degree. Count Rumford attempted to combine the forces of steam and gunpowder together in the following manner. Having procured a number of air bladders of very small fishes, he put different quantities of water into them, from the size of a small pea to that of a pistol bullet, and tying them up with some very fine thread, hung them up to dry on the outside. He then provided a number of cartridges made of fine paper, and filled them with a quantity of gunpowder equal to the usual charge for a common horseman's pistol. He then loaded the pistol with a bullet, fired it against an oaken plank about six feet from the muzzle, and observed the recoil and penetration of the bullet. He next tried the effect of one of these small bladders of water when put among the gunpowder, but always found the force of the powder very much diminished, and the larger the quantity of water the greater was the diminution; the report of the explosion was also diminished in a still greater proportion than the force of the bullet or recoil. It being supposed that the bladder had burst, and thus by wetting the gunpowder prevented it from taking fire, the experiment was repeated with highly rectified spirit of wine, but the diminution of the force was very little inferior to what it had been with water. Etherial oil of turpentine and small quantities of quicksilver were also tried, but with no better success than before. Thinking, however, that the failure of the quicksilver might be owing to its having been too much in a body, the experiment was repeated with the metal dispersed in small particles through the powder. To accomplish this dispersion the more completely, 20 grains of ethiops mineral were mixed very intimately with 145 grains of powder; but still the force of the bullet was much less than if the powder had been used without any addition. As the explosion of pulvis fulminans appears vastly superior to that of gunpowder, some salt of tartar, in its purest state, was mixed in the proportion of 20 grains to 145 of powder; but on firing the piece, it was still found that the force of the explosion was lessened. Sal ammoniac was next tried, which, under certain circumstances, is found to produce a great quantity of air or elastic vapour; but on mixing 20 grains of it with 145 of gunpowder, the force of the explosion was still found to be diminished. As most of the metals, when dissolved in acids, particularly brass in spirit of nitre, are found to produce much elastic vapour, it was thought worth while to try whether the force of powder could be augmented by this means. Twenty

**Gunpow-
der.** grains of brass dust were therefore mixed with 145 grains of powder; but still the force of the explosion was not augmented. In our author's opinion, however, neither brass dust nor ethiops mineral diminish the force of the explosion otherwise than by filling up the interstices between the grains, obstructing the passage of the flame, and thus impeding the progress of the inflammation. Thus it appears, that little hope remains of augmenting the force of gunpowder by any addition either of liquid or inflammable solids: the reason is obvious; viz. because all of them, the liquids especially, absorb great quantities of heat before they can be converted into vapour; and this vapour, after it is formed, requires more heat to make it expand more forcibly than air: hence, as the effects of gunpowder depend entirely upon the emission of a quantity of air, and its rarefaction by vehement heat, the power must be greatly diminished by the absorption of this heat, which ought to be spent in rarefying air. Even solid bodies cannot be set on fire without a previous absorption of heat to convert them into vapour; but liquids have this property still more than solids, and must therefore diminish the explosive force still more. Lime added to gunpowder, however, is said to augment the power of the explosion by one third.

In his experiments on gunpowder, Count Rumford had the curiosity to compare the strength of aurum fulminans, when enclosed in a gun-barrel, with that of common gunpowder; but his experiment only verified what has been found by others, viz. that this powder which in the open air makes such a very violent report, has in close vessels scarce any power, comparatively speaking, either of explosion or projecting a bullet. Count Rumford, however, taking it for granted that the power of aurum fulminans would be found much greater than that of gunpowder, took care to have a barrel of uncommon strength prepared for the experiment. The weight of it was 7 lb. 5 oz.; the length 13.25 inches, and the width of the bore 0.55 inches. This barrel, being charged with 27.44 grains of aurum fulminans and two leaden bullets, which, together with the leather put about them to make them fit the bore without windage, weighed 427 grains; it was laid upon a chafingdish of live coals at the distance of about ten feet from the pendulum, and the piece was directed against the centre of the pendulum. Some minutes elapsed before the powder exploded; but when it did so, the explosion did not much exceed the report of a well-charged air-gun; and it was not until he saw the pendulum in motion, that Count Rumford could be persuaded that the bullets had been discharged. On examination, however, it was found that nothing had been left in the barrel, and that the powder had probably been all exploded, as a great many particles of the revived metal were thrown about. From a calculation of the motion communicated to the pendulum, it was found that the velocity of the bullets had been about 428 feet in a second; whence it appears that the power of aurum fulminans, compared with that of gunpowder, is only as 4 to 13 very nearly.

Method of Trying and Examining GUNPOWDER.—There are two general methods of examining gunpowder; one with regard to its purity, the other with regard to

its strength. Its purity is known by laying two or three little heaps near each other upon white paper, and firing one of them. For if this takes fire readily, and the smoke rises upright, without leaving any dross or feculent matter behind, and without burning the paper, or firing the other heaps, it is esteemed a sign that the sulphur and nitre were well purified, that the coal was good, and that the three ingredients were thoroughly incorporated together: but if the other heaps also take fire at the same time, it is presumed, that either common salt was mixed with the nitre, or that the coal was not well ground, or the whole mass not well beat and mixed together; and if either the nitre or sulphur be not well purified, the paper will be black or spotted.

Several instruments have been invented to try the strength of gunpowder; but they have generally been complained of as inaccurate. Mr Thomson, (now Count Rumford), in the 71st volume of the Philosophical Transactions, gives an account of an exact method of proving the strength of it. "As the force of powder (says he) arises from the action of an elastic fluid that is generated from it in its inflammation, the quicker the charge takes fire, the more of this fluid will be generated in any given short space of time, and the greater of course will its effect be upon the bullet. But in the common method of proving gunpowder, the weight by which the powder is confined is so great in proportion to the quantity of the charge, that there is time quite sufficient for the charge to be all inflamed, even when the powder is of the slowest composition, before the body to be put in motion can be sensibly removed from its place. The experiment therefore may show which of the two kinds of powder is the strongest, when equal quantities of both are confined in equal spaces, and both completely inflamed; but the degree of the inflammability, which is a property essential to the goodness of the powder, cannot by these means be ascertained. Hence it appears how powder may answer to the proof, such as is commonly required, and may nevertheless turn out very indifferent when it comes to be used in service. But though the common powder-triers may show powder to be better than it really is, they can never make it appear to be worse than it is: it will therefore always be the interest of those who manufacture the commodity to adhere to the old method of proof, but the purchaser will find his account in having it examined in a method by which its goodness may be ascertained with greater precision.

From several experiments it appears, that the effect of the charge is considerably augmented or diminished, according to the greater or less force employed in ramming it down. To prevent this inconvenience, Count Rumford advises the use of a cylindrical ramrod of wood, fitted with a metal ring about an inch or an inch and a half in diameter; which being placed at a proper distance from the end which goes up into the bore, will prevent the powder from being too much compressed. In making experiments of this kind, however, it is necessary to pay attention to the heat of the barrel as well as to the temperature of the atmosphere; for heat and cold, dryness and moisture, have a very sensible effect upon gunpowder to augment or diminish its force. When a very great degree of accuracy

therefore

Gunpow-
der.

therefore happens to be requisite, it will be proper to begin by firing the piece two or three times, merely to warm it; after which three or four experiments may be made with standard powder, to determine the proof mark a second time, for the strength of powder is different at different times, in consequence of the state of the atmosphere. After this the experiments may be made with the powder that is to be proved, taking care to preserve the same interval of time between the discharges, that the heat of the piece may be the same in each trial.

Having determined the comparative degrees of strength of two different kinds of powder, their comparative value may be ascertained by augmenting the quantity of the weaker powder till the velocity of the bullets in both cases becomes the same. The strong powder is therefore precisely as much more valuable than the weak, as it produces the same effect with a smaller quantity. Thus if a quarter of an ounce of one kind of powder discharges a bullet with the same velocity that half an ounce of another kind does, it is plain that the former is twice as valuable as the latter, and ought to be sold at double the price.—By comparisons of this kind, Count Rumford found that the best battle powder (so called from its being made at the village of *Battle* in Kent) is stronger than government powder, in the proportion of 4 to 3; but from a comparison of the prices, it appears that the former is no less than $41\frac{2}{3}$ per cent. dearer than it ought to be; and consequently, that whoever uses it in preference to government powder, does it at a certain loss of $41\frac{2}{3}$ per cent. of the money it costs him.

It is supposed by Count Rumford, that very little of the heat acquired in firing a piece of ordnance comes from the powder; for the time that it continues in the piece, perhaps not exceeding the 200th part of a second, is so small, that were the flame *four hundred* times, instead of *four* times, as Mr Robins supposes, hotter than red-hot iron, it is by far too short to communicate a sensible degree of heat to one of our large pieces of cannon. Besides, if the heat of the flame was sufficient to communicate such a degree of heat to the gun, it must undoubtedly be capable of burning up all combustible bodies that come in its way, and of melting lead-shot when such were used; but instead of this, we frequently see the finest paper discharged from the mouth of a gun without being inflamed, after it has sustained the action of the fire through the whole length of the bore; and the smallest lead-shot is discharged without being melted. The objection drawn from the heat of bullets taken up immediately after being discharged from fire-arms does not hold; for bullets discharged from air-guns and even cross-bows are likewise found hot, especially when they happen to strike any hard body, and are much flattened. If a musket ball be discharged into water, or against any very soft body, it will not be sensibly heated; but if it hits a plate of iron or any other body which it cannot penetrate, it will be broken in pieces by the blow, and the dispersed parts will be found in a state little short of actual fusion. Hence our author concludes, that bullets are not heated by the flame, but by percussion. Another objection is, that the vents of brass guns are frequently enlarged to such a degree by repeatedly firing them, that the piece becomes useless.

Gunpow-
der.

But this proves only that brass is easily corroded by the flame of gunpowder; which indeed is the case with iron also. We cannot suppose that in either case any real solution takes place; on the contrary, it is very evident that it does not: for when the vents of fire-arms are lined with gold, they will remain without enlargement for any length of time, though it is well known that gold is much more easily melted than iron. As the heat communicated to bullets, therefore, is not to be ascribed to the flame but to percussion, so the heat acquired by guns is to be attributed, in our author's opinion, to the motion and friction of the internal parts of the metal among themselves by the violent action of the flame upon the inside of the bore. To generate heat, the action of the powder must be not only sufficient to strain the metal, and produce a motion in its parts, but this effect must be extremely rapid; and the effect will be much augmented if the exertion of the force and the duration of its action are momentaneous: for in that case the fibres of the metal that are violently stretched will return with their full force and velocity, and the swift vibratory motion and attrition above mentioned will be produced. Now the effort of any given charge of powder upon the gun is very nearly the same whether it be fired with a bullet or without; but the velocity with which the generated elastic fluid makes its escape, is much greater when the powder is fired alone than when it is made to impel one or more bullets; the heat ought therefore to be much greater in the former than in the latter case, as has been found by experiment. "But to make this matter still plainer, (says our author), we will suppose any given quantity of powder to be confined in a space that is just capable of containing it, and that in this situation it is set on fire. Let us suppose this space to be the chamber of a piece of ordnance, and that a bullet or any other solid body is so firmly fixed in the bore, immediately upon the charge, that the whole effort of the powder shall not be able to remove it: as the powder goes on to be inflamed, and the elastic fluid to be generated, the pressure upon the inside of the chamber will be increased, till at length all the powder being burnt, the strain upon the metal will be at its greatest height, and in this situation things will remain; the cohesion or elasticity of the particles of metal counterbalancing the pressure of the fluid.—Under these circumstances very little heat would be generated; for the continued effort of the elastic fluid would approach to the nature of the pressure of a weight; and that concussion, vibration, and friction among the particles of the metal, which in the collision of elastic bodies is the cause of the heat produced, would scarcely take effect. But instead of being firmly fixed in its place, let the bullet now be moveable, but let it give way with great difficulty, and by slow degrees. In this case the elastic fluid will be generated as before, and will exert its whole force upon the chamber of the piece; but as the bullet gives way to the pressure, and moves on in the bore, the fluid will expand itself and grow weaker, and the particles of the metal will gradually return to their former situations; but the velocity with which the metal restores itself being but small, the vibrations that remains in the metal after the elastic fluid has made its escape will be very languid, as will the heat be which

Gunpow-
der.

is generated by it. But if, instead of giving way with so much difficulty, the bullet is made lighter, so as to afford but little resistance to the elastic fluid in making its escape, or if it is fired without any bullet at all; then, there being little or nothing to oppose the passage of the flame through the bore, it will expand itself with amazing velocity, and its action upon the gun will cease almost in an instant; the strained metal will restore itself with a very rapid motion, and a sharp vibration will ensue, by which the piece will be much heated."

The Count, however, after more mature reflection, a greater number and diversity of experiments, and the increased knowledge which must always accompany such intellectual exertions as have distinguished him through life, has been enabled to evince, that the amazing force of the elastic fluid generated in the combustion of gunpowder, may be fully accounted for on the hypothesis, that it entirely depends on the elasticity of watery vapour, or steam, which is doubled by every increase of temperature equal to 30° of Fahrenheit's thermometer. If then the mean pressure of the atmosphere at the temperature of 212°, equals the elastic force of steam, this force at the temperature of 242° must be equal to the pressure of two atmospheres, since $212 + 30 = 242$, and so on in the same ratio. The Count also found that the elastic force of gunpowder is equal to the pressure of 131,072 atmospheres at the temperature of 722°. By the flame of gunpowder, brass has been known to be melted, which requires a temperature equal to 3807° of Fahrenheit, or 21° of Wedgwood, to bring it to a state of fusion. He also proved in a satisfactory manner, that gunpowder contains a sufficient quantity of water for supplying the requisite proportion of steam; but for a full account of his very ingenious and detailed experiments on this curious subject, we must refer our readers to Nicholson's Journal, vol. i. 4to. p. 459.

It has been proposed to substitute hyperoxymuriate of potash in place of nitre; but the use of this substance is attended with many inconveniences, some of which preclude its being employed in the composition of gunpowder. See CHEMISTRY, N° 959 to N° 967.

To recover damaged GUNPOWDER. The method of the powder-merchants is, to put part of the powder on a sail-cloth, to which they add an equal weight of what is really good; and with a shovel mingle it well together, dry it in the sun, and barrel it up, keeping it in a dry and proper place. Others again, if it be very bad, restore it by moistening it with vinegar, water, urine, or brandy; then they beat it fine, scarce it, and to every pound of powder add an ounce, an ounce and a half, or two ounces, according as it is decayed, of melted saltpetre. Afterwards, these ingredients are to be moistened and mixed well, so that nothing can be discerned in the composition, which may be known by cutting the mass; and then they granulate it as before. In case the powder be in a manner quite spoiled, the only way is to extract the saltpetre with water according to the usual manner, by boiling, filtrating, evaporating, and crystallizing; and then with fresh sulphur and charcoal to make it up anew again.

In regard to the medical virtues of gunpowder, Boerhaave informs us, that the flame of it affords a

very healthy fume in the height of the plague, because the explosive acid vapour of nitre and sulphur corrects the air; and that the same vapour, if received in a small close pent-up place, kills insects.

It is enacted by 5 and 11 of Geo. I. and 5 Geo. II. c. 20. that gunpowder be carried to any place in a covered carriage; the barrels being close-jointed; or in cases and bags of leather, &c. And persons keeping more than 200 pounds weight of gunpowder at one time, within the cities of London and Westminster, or the suburbs, &c. are liable to forfeitures if it be not removed; and justices of the peace may issue warrants to search for, seize, and remove the same.

Gun-Shot Wounds. See SURGERY.

Gun-Smith, a maker of small fire-arms, as muskets, fowling-pieces, pistols, &c.

Gun-Smithery, the business of a gun-smith, or the art of making fire-arms of the smaller sort, as muskets, fowling-pieces, pistols, &c.

The principal part of these instruments is the barrel, which ought to have the following properties. 1. Lightness, that it may incommode the person who carries it as little as possible. 2. Sufficient strength and other properties requisite to prevent its bursting by a discharge. 3. It ought to be constructed in such a manner as not to recoil with violence. And, 4. It ought to be of sufficient length to carry the shot to as great a distance as the force of the powder employed is capable of doing.

The manufacture of fire-arms is now carried to such a degree of perfection by different European nations, that it may perhaps be justly doubted whether any farther improvement in the requisites just mentioned can be made. For the materials, the softest iron that can be procured is to be made use of. The best in this country are formed of *stubs*, as they are called, or old horse-shoe nails; which are procured by the gunsmiths from farriers, and from poor people who subsist by picking them up on the great roads leading to London. These are sold at about 10s. per cwt. and 28 pounds are requisite to form a single musket barrel. The method of manufacturing them from this material is as follows: A hoop of about an inch broad, and six or seven inches diameter, is placed in a perpendicular situation, and the stubs, previously well cleaned, piled up in it with their heads outermost on each side, till the hoop is quite filled and wedged tight with them. The whole then resembles a rough circular cake of iron, which being heated to a white heat, and then strongly hammered, coalesces into one solid lump. The hoop is now removed, and the heatings and hammerings repeated till the iron is rendered very tough and close in the grain; when it is drawn out into pieces of about 24 inches in length, half an inch or more in breadth, and half an inch in thickness.

Four of these pieces are employed for one barrel; but in the ordinary way a single bar of the best soft iron is employed. The workmen begin with hammering out this into the form of a flat ruler, having its length and breadth proportioned to the dimensions of the intended barrel. By repeated heating and hammering this plate is turned round a tempered iron rod called a *mandril*, the diameter of which is considerably smaller than the intended bore of the barrel. One of the edges of the plate being laid over the other about

Gunpow-
der
Gun-
Smithery.

Gun-Smithery.

half an inch, the whole is heated and welded by two or three inches at a time, hammering it briskly, but with moderate strokes, upon an anvil which has a number of semicircular furrows in it, adapted to barrels of different sizes. Every time the barrel is withdrawn from the fire, the workman strikes it gently against the anvil once or twice in an horizontal direction. By this operation the particles of the metal are more perfectly consolidated, and every appearance of a seam in the barrel is obliterated. The mandril being then again introduced into the cavity of the barrel, the latter is very strongly hammered upon it in one of the semicircular hollows of the anvil, by small portions at a time; the heatings and hammerings being repeated until the whole barrel has undergone the operation, and its parts rendered as perfectly continuous as if they had been formed out of a solid piece. To effect this completely, three welding heats are necessary when the very best iron is made use of, and a greater number for the coarser kinds. The French workmen imagine, that by giving the barrel, while in the fire, slight horizontal strokes with the hammer, so as to communicate a vibratory motion to the iron, those particles are thrown off which are in a state of fusion and cannot easily be converted into malleable iron; but considering the great number of operations already described which the metal has undergone, we can scarce suppose this to be of much consequence.

The next operation in forming the barrels is the boring of them, which is done in the following manner: Two beams of oak, each about six inches in diameter, and six or seven feet long, are placed horizontally and parallel to one another; having each of their extremities mortised upon a strong upright piece about three feet high, and firmly fixed. A space of three or four inches is left between the horizontal pieces, in which a piece of wood is made to slide by having at either end a tenon let into a groove which runs on the inside of each beam throughout its whole length. Through this sliding piece a strong pin or bolt of iron is driven or screwed in a perpendicular direction, having at its upper end a round hole large enough to admit the breech of the barrel, which is secured in it by means of a piece of iron that serves as a wedge, and a vertical screw passing through the upper part of the hole. A chain is fastened to a staple in one side of the sliding piece which runs between the two horizontal beams; and passing over a pulley at one end of the machine, has a weight hooked on to it. An upright piece of timber is fixed above this pulley and between the ends of the beams, having its upper end perforated by the axis of an iron crank furnished with a square socket; the other axis being supported by the wall, or by a strong post, and loaded with a heavy wheel of cast iron to give it force. The axes of this crank are in a line with the hole in the bolt already mentioned. The borer being then fixed into the socket of the crank, has its other end, previously well oiled, introduced into the barrel, whose breech part is made fast in the hole of the bolt: the chain is then carried over the pulley, and the weight hooked on; the crank being then turned with the hand, the barrel advances as the borer cuts its way, till it has passed through the whole length. The boring bit consists of an iron rod somewhat longer than the barrel, one end of which fits the socket of the

Gun-Smithery.

crank; the other is adapted to a cylindrical piece of tempered steel about an inch and a half in length, having its surface cut after the manner of a perpetual screw, with five or six threads, the obliquity of which is very small. The breadth of the furrows is the same with that of the threads, and their depth sufficient to let the metal cut by the threads pass through them easily. Thus the bit gets a very strong hold of the metal; and the threads, being sharp at the edges, scoop out and remove all the inequalities and roughness from the inside of the barrel, and render the cavity smooth and equal throughout. A number of bits, each a little larger than the former, are afterwards successively passed through the barrel in the same way, until the bore has acquired the magnitude intended. By this operation the barrel is very much heated, especially the first time the borer is passed through it, by which means it is apt to warp. To prevent this in some measure, the barrel is covered with a cloth kept constantly wetted, which not only preserves the barrel from an excess of heat, but likewise preserves the temper of the bit from being destroyed. The borer itself must also be withdrawn from time to time; both to clean it from the shavings of the metal and to oil it, or repair any damages it may have sustained. Every time a fresh bit has been passed through the barrel, the latter must be carefully examined, to see if it has warped; and likewise if there are any spots, by the workmen called *blacks*, on its inside. When warped, it must be straightened on the anvil; for which a few slight strokes on the convex parts will be sufficient; and this is termed *setting up* the barrel. When black spots are perceived, the corresponding part on the outside must be marked, and driven in by gentle strokes with the hammer, when they will be completely removed by passing the borer another time through the piece.

The equality of the bore is of the utmost consequence to the perfection of a barrel; inasmuch that the greatest possible accuracy in every other respect will not make amends for any deficiency in this. The method used by gunsmiths to ascertain this is by a cylindrical plug of tempered steel highly polished, about an inch in length, and fitting the bore exactly. This is screwed upon the end of an iron rod, and introduced into the cavity of the barrel, where it is moved backwards and forwards; and the places where it passes with difficulty being marked, the boring bit is repeatedly passed until it moves with equal ease through every part. Any person who wishes to know the merit of his piece in this respect, may do it with tolerable accuracy by means of a plug of lead cast on a rod of iron; or even by a musket ball filed exactly to the bore, and pushed through the barrel by a rammer; taking care, however, not to use much force lest the ball be flattened, and its passage thus rendered difficult.

The last step towards the perfection of the inside of the barrel is termed *finishing*; by which is meant the smoothing it in such a manner as to remove all marks and inequalities left by the borer. The fine borer resembles the other in its general construction; but instead of the piece of steel cut in form of a screw, which belongs to that, it is furnished with a square breech, 10 or 12 inches long, highly polished, and very sharp, by which means it cuts the metal very smoothly. It is found to answer the purpose best when only two of its

Gun-Smithery.

Gun-Smithery.

its edges are allowed to work ; the other two are covered with slips of oiled paper, one or more additional slips being put on each time that the instrument is passed through the barrel. The fine-borer is frequently passed through, from the muzzle to the breech, and from the breech to the muzzle, until the whole inside presents a perfectly equal and polished surface ; the barrel being likewise examined and set up, if requisite, after each time. It is absolutely necessary that this instrument should be perfectly true, and not in the least cast or warped in the tempering.

Besides the operations above described, another, called *polishing*, is usually performed on gun-barrels, though it is doubtful whether this last be attended with any good effect or not. It is performed by a cylinder of lead, five or six inches long, cast upon a rod of iron, and filed exactly to the bore. The lead being then covered with very fine emery and oil, is wrought backwards and forwards through the whole length of the barrel until the inside has acquired the requisite degree of polish. The disadvantages of this operation are, that it is scarce possible to perform it without pressing more upon one part than another, and thus producing some degree of inequality on the inside, which is of the very worst consequence to fire-arms. The polish thus given is likewise very perishable ; so that the fine-boring may justly be considered as the last operation necessary for the inside of a barrel ; and it is then proper to give the external form and proportions by means of a file. For this purpose, four faces are first formed upon it, then eight, then 16 ; and so on till it be quite round, excepting the part next the breech, called the *reinforced part*, which is always left of an octagonal form. It being absolutely necessary that the barrel should be equally thick on every side, gunsmiths employ, for accomplishing this purpose, a particular tool named a *compass*. This consists of an iron rod bent in such a manner as to form two parallel branches about an inch distant from each other. One of these branches is introduced into the barrel, and kept closely applied to the side, by means of one or more springs with which it is furnished : the other descends parallel to this on the outside, and has several screws passing through it with their points directed to the barrel. By screwing these until their points touch the surface of the barrel, and then turning the instrument round within the bore, we perceive where the metal is too thick, and how much it must be reduced, in order to render every part perfectly equal throughout its circumference. It may be made long enough to reach the whole length of the barrel, though it will be more convenient to have it only half as much, and to introduce it first at one end and then at the other. Instead of rounding the barrel by means of a file and compass, however, some people do so by turning it in a lathe ; which is no doubt more expeditious, though neither so certain nor exact. A spindle as long as a gun-barrel cannot, without great difficulty, be prevented from springing considerably under the tool employed to reduce or smooth it in turning ; whence it is found, that by this operation barrels are more frequently warped than by all the boring they undergo ; and there is now this farther inconvenience, that they cannot be set up as formerly, without danger of destroying them entirely.

The barrels being thus bored and formed externally,

it is customary with the gunsmiths in France to solder on the loops and aim before they breech the barrel. The English, however, do not restrict themselves in this manner : for as soft solder is sufficient for fastening on these, they never use any other ; while the French, who use hard solder, must of consequence employ a great heat. Thus the inside is roughened sometimes so considerably, that it is necessary to repeat the fine boring ; which could not be done without injuring the threads of the screw formed for the breech, if the barrel were prepared for the latter without soldering on the former.

The first tool employed in forming the breech-screw is a plug of tempered steel, somewhat conical, with the threads of a male screw upon its surface, and by the workmen termed a *scroto tap*. This being introduced into the barrel, and worked from left to right and back again, until it has marked out the four first threads of the screw, another less conical tap is introduced ; and when this has carried the impression of the screw as far as it is intended to go, a third one, nearly cylindrical, is made use of, scarcely differing from the plug of the breech intended to fill the screw thus formed in the barrel. The plug itself has its screw formed by means of a screw-plate of tempered steel, with several female screws, corresponding with the taps employed for forming that in the barrel. Seven or eight threads are a sufficient length for a plug : they ought to be neat and sharp, so as completely to fill the turns made in the barrel by the tap. The breech plug is then to be case-hardened, or to have its surface converted into steel, by covering it with shavings of horn, or the parings of the hoofs of horses, and keeping it for some time red hot ; after which it is plunged in cold water.

The only thing now requisite for completing the barrels is to give them a proper colour ; as a preparation for which their outside is first to be neatly polished with oil and emery. This being done, it was formerly the custom to give such a degree of heat as would make them blue throughout ; but as this cannot be effected without a partial calcination of the surface, which of consequence affects the inside also, the blue colour has been for some time disused, and a brown one substituted in its place. To give this colour, the pieces are first rubbed over with aquafortis or spirit of salt diluted with water ; after which they are laid by till a complete coat of rust is formed upon them : a little oil is then applied ; and the surface being rubbed dry, is polished by means of a hard brush and bees-wax.

Thus the common musket barrels for the purposes especially of sportsmanship are made ; but there are some other methods of manufacture, by which the barrels are made to differ in some respects from those just described, and are thought to be considerably improved. One kind of these are called *twisted* barrels ; and by the English workmen are formed out of the plates made of *stubs* formerly described. Four of these, of the size already mentioned, are requisite to make one barrel. One of them heated red hot for five or six inches is turned like a cork-screw by means of the hammer and anvil ; the remaining parts being treated successively in the same manner until the whole is turned into a spiral, forming a tube, the diameter of which corresponds with the bore of the intended barrel. Four are generally sufficient to form a barrel of the ordinary length, i. e.

Gun-Smithery. from 32 to 38 inches; and the two which form the breech or strongest part, called the *reinforced part*, are considerably thicker than those which form the muzzle or fore part of the barrel. One of these tubes is then welded to a part of an old barrel to serve as a handle; after which the turns of the spiral are united by heating the tube two or three inches at a time to a bright white heat, and striking the end of it several times against the anvil in a horizontal direction with considerable strength, which is called *jumping the barrel*; and the beats given for this purpose are called *jumping heats*. The next step is to introduce a mandril into the cavity, and to hammer the heated portion lightly in order to flatten the ridges or burs raised by the jumping at the place where the spirals are joined. As soon as one piece is jumped throughout its whole length, another is welded to it, and treated in the same manner, until the four pieces are united, when the part of the old barrel is cut off, as being no longer of any use. The welding is repeated three times at least, and is performed exactly in the same manner as directed for plain barrels; and the piece may afterwards be finished according to the directions already given.

The operation for the French twisted barrels is very different from that just mentioned, and much more exceptionable. It consists in heating the barrel by a few inches at a time to a strong red heat; one end is then screwed into a vice, and a square piece of iron with an handle like an auger is introduced into the other. By means of these the fibres of the heated portion are twisted into a spiral direction, which is supposed to resist the effort of the inflamed powder better than the other. To render this operation complete, however, it must be observed, that when once the several portions of the barrel have been twisted, the subsequent heats ought not to be very great, or the grain of the metal will regain its former state, and the barrel be no better for the twisting than before. To twist a barrel in this manner, also, it will be necessary to forge it at least half a foot longer than it is intended to be, that a sufficient length may be kept cold at each end to give a sufficient purchase to the vice and twisting instrument; and these portions must afterwards be cut off before the barrel is bored, or two pieces of an old barrel may be welded to the muzzle and breech of that which is to be twisted, and cut off when the operation is over. These pieces may also be made stronger than usual to resist the force of the vice and twisting instrument; and in order to give the latter a firmer hold, the cavity of the muzzle may be made of a square form. The English workmen are unanimously of opinion that this method of twisting is really injurious to the barrel, by straining the fibres of the metal. At any rate, from the injudicious methods followed by the French artists, the greatest part of their barrels, said to be twisted, are not so in reality; there being at least six or seven inches at the muzzle, and seven or eight at the breech, which are not affected by the operation.

The French *ribbon barrels* have a great resemblance to the English twisted ones: but the process for making them is much more operose, though it seems not to possess any real advantage over that used by the English artists. A plate of iron, about the twelfth part of an inch in thickness, is turned round a mandril, and welded its whole length in the same manner as a plain bar-

rel. Upon this slight barrel, which is called the *lining*, a plate of iron about an inch in breadth, and bevelled off at the edges, is by means of successive heats rolled in a spiral direction; after which it is termed the *ribbon*, and must have a thickness corresponding with that part of the barrel which it is to form. As it would, however, be difficult to form a ribbon of sufficient length for the whole barrel, it is made in several pieces; and when one piece is rolled on, another is welded to its end, and the operation continued until the lining be entirely covered. The edges are so much bevelled, that the one folds over the other about a quarter of an inch. After the ribbon is all rolled on, the barrel must be heated by two or three inches at a time, and the turns of the spiral united to each other and to the lining by being welded in the same manner as the twisted barrel; though, from what has been said of the construction of these barrels, it is plain that the operation of *jumping* cannot be admitted in them. The barrel is afterwards bored in such a manner that almost the whole of the lining is cut out, and scarce any thing left but the ribbon with which the lining was covered.

The superiority of twisted and ribbon barrels over the plain kind gave occasion to a third sort named *wired barrels*. These were invented by an ingenious workman at Paris named *Barrois*; whose method was as follows: Upon a thin barrel, filed and dressed as usual, he rolled, as close as possible, and in a spiral direction, a tempered iron wire about the thickness of a crow-quill, the first layer covering only the reinforced part. The turns of the wire were soldered to each other and to the barrel with a composition which he kept a secret. The wired part was then filed smooth and bright, but not so much as to weaken it; a second layer of wire was applied over the first, extending two-thirds of the length of the barrel; and this being smoothed and brightened like the first, a third layer was applied, which covered the two former and reached quite to the muzzle.

The barrels made after this manner are supposed to be much superior to others, though the supposition seems not to be well founded. It is certain that wire is not preferable to other iron as a material for gun-barrels: and the solder used by M. Barrois in a quantity nearly equal to the wire itself, must be accounted a defect as far as it was used; for no metal has yet been found equal to iron for the purposes of gunsmiths: so that by the use of so much of this solder in the composition of the barrel, it must be undoubtedly weaker than if it had been all made of iron. We are not to suppose the wire absolutely free from flaws; and even though it were, there will always be small cavities between its turns, which the solder cannot fill completely. Besides, as the operation of wiring was performed by M. Barrois upon a barrel that had been previously bored and dressed within, the repeated heats to which it was afterwards subjected in soldering, if they did not cause it warp, at least rendered it so rough that it was necessary to fine-bore it afterwards. The only advantage therefore which these barrels were found to possess was their beautiful appearance; which was greatly overbalanced by the circumstances just mentioned, as well as by the extravagant prices at which they were sold; a single barrel being sold at 5*l*. and a double one at twice that sum; whence the sale of them

Gun-Smithery. them never answered the expectation of the inventor, and after his death nobody thought of making them.

The Spanish barrels have long been held in great estimation, both on account of their being formed of better iron than those of other countries, and likewise from an opinion of their being more perfectly forged and bored. Those made at Madrid are the best, and even of these such as have been made by former gunsmiths are in the greatest estimation. The most celebrated Spanish gunsmiths were Nicholas Biz, who lived in the beginning of the present century, and died in 1724; and the barrels fabricated by him in the former part of his life are held in greatest estimation. Those of his cotemporaries, Juan Belan and Juan Fernandez, are no less valued; all of their barrels selling in France at 1000 livres, or 45l. 15s. sterling. The successors of these great artists were Diego Esquibal, Alonzo Martinez, Agostin Ortiz, Matthias Vaera, Luis Santos, Juan Santos, Francisco Garcia, Francisco Targarone, Joseph Cano, and N. Zelaya. The most celebrated after these were Francisco Loper, Salvador Cenarro, Miguel Zeguarra, Isidoro Soler, and Juan de Soto. The three first are gunsmiths to the king; and the barrels made by all of them sold for 13l. sterling. Almost all the Madrid barrels are composed of the old shoes of horses and mules, which are all collected for the purpose. They are manufactured first by welding longitudinally, and then being joined together in four or five pieces like the English barrels made from stubs, as already mentioned. In this, and indeed all other operations for making gun-barrels, an immense waste of the iron takes place; but that of the Spanish iron is by far the greatest, a mass of 40 or 45 pounds being required to make one barrel, which when rough from the forge weighs only six or seven pounds; so that from 30 to 38 pounds are lost in the hammerings. It may perhaps, however, be doubted, whether the iron be really purified by this waste; for it is certain, that by long continued working in the fire it may be rendered totally useless and destroyed; neither can we be assured that the other advantages pretended to result from their method of manufacture are of any consequence. The Spanish artists likewise value themselves on giving the inside of their barrels a very high polish; but the advantage of this, as has already been observed, is extremely dubious. The only thing requisite in a gun-barrel is that it do not lead; that is, that the mark of the bullet be not perceived on the inside after it has been discharged, by some of the lead rubbed off as it passes through. In the opinion of very good judges, therefore, it is better to take a barrel immediately after it has undergone the operation of fine-boring than to give it any higher polish; and in support of this opinion, M. de Marolles, an author of great reputation, informs us, that he has seen a barrel rough from the borer throw a charge of shot deeper into a quire of paper than one which was highly polished within, though the length, bore, and charge, were the same in both.

As the Spanish iron is universally allowed to be excellent, it has not been unreasonably supposed that the superiority of the barrels manufactured in that kingdom is owing more to the goodness of the materials than to the skill of the workmen. It must be observed, however, that instead of making the plates overlap a

little in the place where they join, they give one of them a complete turn; so that every Spanish barrel may be said to be double throughout its whole length. The different portions of the iron are also forged in such a manner, that the grain of the iron is disposed in a spiral manner; whence it has the same effect with a ribbon or twisted barrel. The outside is finished by turning them in a lathe; whence probably they are always less elegantly wrought than the French and English pieces. The great value put upon them is also thought to be more owing to fancy than to any real good qualities they possess. Formerly they were made from three to three feet and a half long; their bore being such as to admit a bullet from 22 to 24 in the pound; and their weight from three to three pounds and a half. The reinforced part extends two-fifths of the length; and at 10 or 12 inches from the breech is placed a *sight*, such as is usually put upon rifle-barrels or those intended only for ball. According to Lapinas, arquebuss-bearer to Philip IV. the weight of a Spanish barrel ought to be four pounds and a half when their length is 42 inches; but both weight and length are now much reduced, they seldom exceeding the dimension already mentioned. Next to the barrels made at Madrid, the most esteemed are those of Bustindui and St. Olabe at Placentia in Biscay; and of Jeun and Clement Padwesteva, Eudal Pous, and Martin Marechal, at Barcelona; the usual price of them being about 3l. 10s. sterling.

Having now described the method of forging barrels, we shall next proceed to give an account of those imperfections to which they are sometimes liable, and which render them apt to burst or recoil with violence. The principal of these are the *chink*, *crack*, and *flaw*. The first is a small rent in the direction of the length of the barrel; the second across it; and the third is a kind of scale or small plate adhering to the barrel by a narrow base, from which it spreads out like the head of a nail from its shank, and when separated leaves a pit or hollow in the metal. The chink or flaw is of much worse consequence than the crack in fire-arms, the force of the powder being exerted more upon the circumference than the length of the barrel. The flaw is much more frequent than the chink, the latter scarce ever occurring but in plain barrels formed out of a single plate of iron, and then only when the metal is deficient in quality. When flaws happen on the outside, they are of no great consequence; but in the inside they are apt to lodge moisture and foulness which corrode the iron, and thus the cavity enlarges continually till the piece bursts. This accident, however, may arise from many other causes besides the defect of the barrel itself. The best pieces will burst when the ball is not sufficiently rammed home, so that a space is left between it and the powder. A very small windage or passage for the inflamed powder between the sides of the barrel and ball will be sufficient to prevent the accident; but if the ball has been forcibly driven down with an iron ramrod, so as to fill up the cavity of the barrel very exactly, the piece will almost certainly burst, if only a very small space be left between it and the powder; and the greater the space is, the more certainly does the event take place. Of this Mr Robins gives a remarkable instance, accounting at the same time for the phenomenon. "A moderate charge of powder (says he), when

Gun-Smithery.

Gun-Smithery.

it has expanded itself through the vacant space and reaches the ball, will, by the velocity each part has acquired, accumulate itself behind the ball, and will thereby be condensed prodigiously: whence, if the barrel be not of an extraordinary strength in that part, it must infallibly burst. The truth of this I have experienced in a very good Tower musket forged of very tough iron: for charging it with 12 pennyweights of powder, and placing the ball loosely 16 inches from the breech; on the firing of it, the part of the barrel just behind the bullet was swelled out to double its diameter like a blown bladder, and two large pieces of two inches in length were burst out of it." A piece will frequently burst from having its mouth stopped up with earth or snow; which accident sometimes happens to sportsmen in leaping a ditch, in which they have assisted themselves with their fowling-piece, putting the mouth of it to the ground; and when this does not happen, it is only to be accounted for from the stoppage being extremely slight. For the same reason a musket will certainly burst if it be fired with the muzzle immersed only a very little way in water. It will also burst from an overcharge; but when such an accident happens in other circumstances, it is most probably to be attributed to a defect in the workmanship, or in the iron itself. These defects are principally an imperfection in the welding, a deep flaw having taken place, or an inequality in the bore; which last is the most common of any, especially in the low-priced barrels. The reason of a barrel's bursting from an inequality in the bore is, that the elastic fluid, set loose by the inflammation of the powder, and endeavouring to expand itself in every direction, being repelled by the stronger parts, acts with additional force against the weaker ones, and frequently bursts through them, which it would not have done had the sides been equally thick and strong throughout. With regard to defects arising from the bad quality of the iron, it is impossible to say any thing certain. As the choice of the materials depends entirely on the gunsmith, the only way to be assured of having a barrel made of proper metal is to purchase it from an artist of known reputation, and to give a considerable price for the piece.

The recoil of a piece becomes an object of importance only when it is very great; for every piece recoils in some degree when it is discharged. The most frequent cause of an excessive recoil is an inequality in the bore of the barrel; and by this it will be occasioned even when the inequality is too small to be perceived by the eye. The explanation of this upon mechanical principles indeed is not very easy: for as it is there an invariable law, that action and re-action are equal to one another, we should be apt to suppose that every time a piece is discharged it should recoil with the whole difference between the velocity of the bullet and that of the inflamed powder. But were this the case, no man could fire a musket without being destroyed; for the bullet flies out only with a velocity of 1700 feet in a second, or not much more, while that of the powder, as calculated by Mr Robins, is not less than 7000 feet in the same space. But was the recoil to be made with the difference of these velocities, or with one half of it, it is plain that no man could bear it. The same thing therefore must take place in the recoil of a musket, which Dr Priestley observed in his experi-

Gun-Smithery.

ments on the explosion of inflammable and dephlogisticated air, viz. that the force is exerted much more upon the part farthest from that where the inflammation begins than upon that next to it. At any rate, however, the strength of the recoil will always be found proportionable to the weight of the piece; that is, the lighter the piece is, the greater the recoil, and *vice versa*. The recoil may be increased by any thing which retards the passage of the shot; whence it is also augmented by the foulness of the barrel by repeated firing. M. de Marolles informs us also, that a piece will recoil, if, from the breech-plug being made too short, some turns of the screw remain empty; as in these a part of the powder is lodged which forms an obstacle to the explosion; though in what manner this takes place is not very apparent, as, though the powder lodged there might contribute little or nothing to the force of the explosion, it can scarce be shown to stand in the way of it. The same author likewise informs us, that a barrel mounted upon a very straight stock will recoil more than upon one that is considerably bent. Sometimes also a fowling-piece will recoil from the sportsman applying it improperly to his shoulder; though this last circumstance seems likewise inexplicable. It is most probable therefore that the supposed *greater* recoil taken notice of in this case, arises only from the usual recoil being more sensibly felt in one position than another.

The cause to which too great a recoil in muskets has been usually attributed, is the placing of the touch-hole at some distance from the breech-plug; so that the powder is fired about the middle, or towards its fore part, rather than at its base. To avoid this, some artists form a groove or channel in the breech-plug as deep as the second or third turn of the screw; the touch-hole opening into this channel, and thus firing the powder at its very lowest part. It appears, however, from a number of experiments made upon this subject by M. le Clerc gunsmith to the king of France, that it made very little difference with regard to the recoil, whether the touch-hole was close to the breech or an inch distant from it. The only circumstance to be attended to with respect to its situation therefore is, that it be not quite close to the breech-plug; as in such a case it is found to be more apt to be choked up than when placed about a quarter of an inch from it.

The only other circumstance now to be determined with regard to musket-barrels is their proper length. Formerly it was supposed that the longer they were made, the greater would be the distance to which they carried the shot, and that without any limitation. This opinion continued to prevail till about half a century ago, when it was first proposed as a doubt whether long barrels carried farther than short ones. With regard to cannon, indeed, it had long before this time been known that they might be made too long; and Balthazar Killar, a celebrated cannon-founder in the reign of Louis XIV. was able to account for it. When asked by Mons. Suriry de St Remy, why the culverin of Nancy, which is 22 feet long, did not carry a ball equally far with a shorter piece? he replied, that "the powder, when inflamed, ought to quit the cavity of the piece in a certain time, in order to exert its whole force upon the bullet: by a longer stay, part of the

force

Gun-
Smithery.

force is lost; and the same cause may produce an inequality in the shots, by giving a variation to the bullet, so as to destroy its rectilinear course, and throw it to one side or other of the mark." Mr Robins, who on this as well as every other question in gunnery has almost exhausted the subject, informs us, that "if a musket-barrel, of the common length and bore, be fired with a leaden bullet and half its weight of powder, and if the same barrel be afterwards shortened one-half and fired with the same charge, the velocity of the bullet in this shortened barrel will be about one-sixth less than what it was when the barrel was entire; and if, instead of shortening the barrel, it be increased to twice its usual length, when it will be near eight feet long, the velocity of the bullet will not hereby be augmented more than one-eighth part. And the greater the length of the barrel is in proportion to the diameter of the bullet, and the smaller the quantity of powder, the more inconsiderable will these alterations of velocity be." From these considerations it appears, that the advantages gained by long barrels are by no means equivalent to the disadvantages arising from the weight and incumbrance of using them; and from a multitude of experiments it is now apparent, that every one may choose what length he pleases, without any sensible detriment to the range of his piece. The most approved lengths are from 32 to 38 inches.

An opinion has generally prevailed among sportsmen, that by some unknown manoeuvre the gunsmith is able to make a piece, loaded with small shot, throw the contents so close together, that even at the distance of 40 or 50 paces the whole will be confined within the breadth of a hat. From such experiments as have been made on this subject, however, it appears, that the closeness or wideness with which a piece throws its shot is liable to innumerable variations from causes which no skill in the gunsmith can possibly reach. So variable are these causes, that there is no possibility of making the same piece throw its shot equally close twice successively. In general, however, the closer the wadding is, the better disposed the shot seems to be to fall within a small compass. The closeness of the shot therefore would seem to depend in a great measure on preventing the flame of the powder from insinuating itself among its particles: whence the following method is said to be practised with success by those who shoot for a wager at a mark with small shot; viz. to put in the shot by small quantities at a time, ramming down a little tow or thin paper over each; so as to fill the interstices of the grains, and thus prevent the flame from getting in amongst the grains and scattering them. In firing with small shot, a curious circumstance sometimes occurs, viz. that the grains, instead of being equally distributed over the space they strike, are thrown in clusters of 10, 12, 15, or more; whilst several considerable spaces are left without a grain in them. Sometimes one-third or one-half of the charge will be collected into a cluster of this kind; nay, sometimes, though much more rarely, the whole charge will be collected into one mass, so as to piece a board near an inch thick at the distance of 40 or 45 paces. Small barrels are said to be more liable to this clustering than large ones: and M. de M'arolles informs us, that this is especially the case when the barrels are new, and likewise when they are fresh-

Gun-
Smithery.

washed; though he acknowledges that it did not always happen with the barrels he employed even after they were washed. It is probable, therefore, that the closeness of the shot depends on some circumstances relative to the wadding rather than to the mechanism of the barrel.

Some pieces are composed of two or more barrels joined together; in which case the thickness of each of the barrels is somewhat less than in single-barrelled pieces. After being properly dressed, each of them is filed flat on the side where they are to join each other, so that they may sit more closely together. Two corresponding notches are then made at the muzzle and breech of each barrel; and into these are fitted two small pieces of iron to hold them more strongly together. Being then united by timing the contiguous parts, a triangular piece of iron called the *rib* is fastened on in like manner, running the whole length on the upper side; which serves to hold them more strongly together. After this they are to be polished and coloured in the manner described for single barrels. Great care should be taken that the barrels joined in this manner should be quite equal in strength to one another, and that both should be quite upright, or of an equal thickness throughout. If any inequality takes place in the strength of the barrels, the weaker will be warped by the action of the stronger; and the warping from this cause has sometimes been so considerable as to render one of the barrels useless. To bring every part of the circumference of each barrel to an equal strength as nearly as possible, so that no part may be strained by the explosion, that side where they touch each other must be so reduced, that the partition between the two calibres may be no thicker than either barrel was at the same place before it was filed to join in this manner. Formerly the double-barrelled pieces were made with one barrel lying over the other, each barrel having a separate pan, hammer, and hammer-spring, but only one cock for both. The barrels were therefore made to turn round at the place where the breeches joined with the stock; so that as soon as one was fired off, the other could be brought into its place by pressing a spring moved by the guard with the right hand, while with the left the barrels were turned upon their common axis; and as soon as the charged barrel was thus brought into its proper situation, the spring descended into a notch and kept it firm. But this method was found to be too complicated and embarrassed, though upon the same plan three and four barrels were sometimes mounted upon one stock; but these pieces were intolerably heavy, and have no real superiority over the double-barrelled pieces which do not turn round, and which of consequence are now only made use of.

In forging barrels of all kinds, it is of considerable importance to have them made at first as near as possible to the weight intended when they are finished, so that very little be taken away by the boring and filing: for as the outer surface, by having undergone the action of the hammer more immediately than any other part, is rendered the most compact and pure, we should be careful to remove as little of it as possible; and the same holds, though in a less degree, with the inside which is to be cut with the borer. Pistol-barrels are forged in one piece, two at a time, joined by their muzzles,

Gen-
Smithery
Gunter's
line.

muzzles, and are bored before they are cut asunder; by which means there is not only a saving of time and labour, but a greater certainty of the bore being the same in both.

GUNTER, EDMUND, an excellent English mathematician and astronomer, was born in Hertfordshire in 1581, and studied at Westminster-school; from whence he removed to Oxford, where he took the degree of master of arts in 1606, and afterwards entered into holy orders. In 1615 he took the degree of bachelor of divinity: but being peculiarly eminent for his knowledge in the mathematics, he had two years before been chosen professor of astronomy in Gresham college, London; where he distinguished himself by his lectures and writings. He invented a small portable quadrant; and also the famous line of proportions, which, after the inventor, is called *Gunter's scale*. He likewise published *Canon Triangulorum*; and a work entitled *Of the Sector, Cross-staff, and other instruments*. This last was published, with an English translation of his *Canon Triangulorum*, in 4to, by Samuel Foster professor of Gresham-college. Mr Gunter died at that college in 1626.

GUNTER'S Line, a logarithmic line, usually graduated upon scales, sectors, &c.

It is also called the *line of lines* and *line of numbers*; being only the logarithms graduated upon a ruler, which therefore serves to solve problems instrumentally in the same manner as logarithms do arithmetically. It is usually divided into 100 parts, every tenth whereof is numbered, beginning with 1 and ending with 10: so that if the first great division, marked 1, stand for one-tenth of any integer, the next division, marked 2, will stand for two-tenths, 3, three-tenths, and so on; and the intermediate divisions will in like manner represent 100th-parts of the same integer. If each of the great divisions represent 10 integers, then will the lesser divisions stand for integers; and if the greater divisions be supposed each 100, the subdivisions will be each 10.

Use of GUNTER'S Line. 1. *To find the product of two numbers.* From 1 extend the compasses to the multiplier; and the same extent, applied the same way from the multiplicand, will reach to the product. Thus if the product of 4 and 8 be required, extend the compasses from 1 to 4, and that extent laid from 8 the same way will reach to 32, their product. 2. *To divide one number by another.* The extent from the divisor to unity will reach from the dividend to the quotient: thus, to divide 36 by 4, extend the compasses from 4 to 1, and the same extent will reach from 36 to 9, the quotient sought. 3. *To three given numbers to find a fourth proportional.* Suppose the numbers 6, 8, 9: extend the compasses from 6 to 8; and this extent, laid from 9 the same way, will reach to 12, the fourth proportional required. 4. *To find a mean proportional between any two given numbers.* Suppose 8 and 32: extend the compasses from 8, in the left-hand part of the line, to 32 in the right; then bisecting this distance, its half will reach from 8 forward, or from 32 backwards, to 16, the mean proportional sought. 5. *To extract the square-root of any number.* Suppose 25: bisect the distance between 1 on the scale and the point representing 25; then the half of this distance, set off from 1, will give the point representing the

root 5. In the same manner the cube root, or that of any higher power, may be found by dividing the distance on the line between 1 and the given number into as many equal parts as the index of the power expresses; then one of those parts, set from 1, will find the point representing the root required.

GUNTER'S Quadrant, one made of wood, brass, &c. containing a kind of stereographic projection of the sphere, on the plane of the equinoctial; the eye being supposed placed in one of the poles.

GUNTER'S Scale, called by navigators simply the *gunter*, is a large plain scale, generally two feet long, and about an inch and a half broad, with artificial lines delineated on it, of great use in solving questions in trigonometry, navigation, &c.

GUNWALE, or **GUNNEL**, is the uppermost wale of a ship, or that piece of timber which reaches on either side from the quarter-deck to the fore-castle, being the uppermost bend which finishes the upper works of the hull, in that part in which are put the stanchions which support the waste trees.

GURK, an episcopal town of Carinthia in Germany, seated on the river Gurk, in E. Long. 14. 18. N. Lat. 47. 12.

GURNARD. See TRIGLA, ICHTHOLOGY Index.

GUST, a sudden and violent squall of wind, bursting from the hills upon the sea so as to endanger the shipping near the shore. These are peculiar to some coasts, as those of South Barbary and Guinea.

GUSTAVIA, a genus of plants belonging to the monadelphia class. See BOTANY Index.

GUSTAVUS I. king of Sweden, son of Eric de Vasa duke of Gripsholm. Christian II. king of Denmark having made himself master of the kingdom of Sweden, confined Gustavus at Copenhagen; but he making his escape, wandered a long time in the forests, till the cruelties of the tyrant having occasioned a revolution, he was first declared governor of Sweden, and in 1513 elected king. This prince introduced Lutheranism into his dominions, which in a little time spread itself all over the kingdom. He died in 1560; having made his kingdom hereditary, which was before elective. See SWEDEN.

GUSTAVUS Adolphus, surnamed the *Great*, king of Sweden, was born at Stockholm in 1594, and succeeded his father Charles in 1611. He espoused the cause of the Protestants in Germany, who were oppressed and almost entirely ruined by the emperor Ferdinand. He was a great warrior, and gained many victories, of which an account is given under the article SWEDEN. He was at last killed in the battle of Lutzen, where his troops got the victory, and defeated two of the emperor's armies.

GUTHALUS, or **GUTTALUS**, in *Ancient Geography*, is thought to be the *Viadrus* of Ptolemy. Now the *Oder*, which rising in Moravia, runs through Silesia, Brandenburg, and Pomerania, into the Baltic.

GUTTA, a Latin term for what in English we call *drop*.

GUTTA Rosacea, in *Medicine*, denotes a red or pimpled face; a distemper which, though not always owing its original to hard drinking, is nevertheless most incident to tipplers of strong beer, wines, spirits, &c.

GUTTA Serena, a disease in which the patient, with-

Gunter's
line
Gutta.

Gutta
|
Guy.

out any apparent fault in the eye, is deprived of sight. See *MEDICINE Index*.

GUTTA, in *Architecture*, are ornaments in the form of little cones used in the Doric cornice, or on the architrave underneath the triglyphs, representing a sort of drops or bells.

GUT-TIE, a disease incident to oxen and male calves at the time of castration. In the county of Hereford, those who breed cattle open the scrotum of their calves, and forcibly extract the testicles with their teeth, in consequence of which every vessel is ruptured belonging to these parts. The vasa deferentia are separated from the testicles, and form a kind of bow from the urethra, where they are united to the transverse muscles. The jejunum is the part of the gut that is tied, where it turns from the right to the left, and from the left to the right. As the bow of the gut hangs over the vasa deferentia, a hitch is formed over the bow of the gut, analogous to what is made by a carter over his cart line. In this manner an obstruction is occasioned in the bowels, which terminates in a mortification, commonly proving fatal in the course of four days.

The symptoms which attend a gut-tie resemble those of an incurable colic, or mortification of the intestines. To ascertain the distinction between the gut-tie and the colic, the hand and arm of the operator ought to be oiled, in which state it should be introduced into the anus. Here the string will be found united to the muscles, and without occasioning any pain to the animal, may be traced with ease to the stricture by the hand.

Mr Harris, farmer at Wickton, informs us, that the gut-tie may be prevented by the following simple and easy method of castration. "Open the scrotum, loosen out the testicles, and tie the several vessels with a waxed thread or silk, or sear them with a hot iron, to prevent their bleeding, as in the common way of cutting colts. This method can never displace the vessels of the bladder, testicles, kidneys, or intestines; all of which remained covered or attached to the peritonæum, or lining of the abdomen of the beast, which renders it impossible that there should ever be a stricture or tie on the gut."

GUTTURAL, a term applied to letters or sounds pronounced or formed as it were in the throat.

GUTTY, in *Heraldry*, a term used when any thing is charged or sprinkled with drops. In blazoning, the colour of the drops is to be named: as gutty of sable, of gules, &c.

GUY, THOMAS, an eminent bookseller, founder of the hospital for sick and lame in Southwark bearing his name, was the son of Thomas Guy, lighterman and coal-dealer in Horsley-down, Southwark. He was put apprentice, in 1660, to a bookseller in the porch of Mercer's chapel; and set up trade with a stock of about 200*l.* in the house that forms the angle between Cornhill and Lombard-street. The English Bibles being at that time very badly printed, Mr Guy engaged with others in a scheme for printing them in Holland and importing them; but this being put a stop to, he contracted with the university of Oxford for their privilege of printing them, and carried on a great bible-trade for many years to a considerable advantage. Thus he began to accumulate money, and his gains rested in his

hands; for being a single man, and very penurious, his expences could not be great, when it was his custom to dine on his shop counter with no other table-covering than an old newspaper: and besides he was not more scrupulous about the style of his apparel. The bulk of his fortune, however, was acquired by purchasing seamen's tickets during Queen Anne's wars, and by South-Sea stock in the memorable year 1720. To show what great events spring from trivial causes, it is asserted, that the public owe the dedication of the greatest part of his immense fortune to charitable purposes, to the indiscreet officiousness of his maid-servant in interfering with the mending of the pavement before the door. Guy had agreed to marry her, and, preparatory to his nuptials, had ordered the pavement before his door, which was in a neglected state, to be mended, as far as to a particular stone which he pointed out. The maid, while her master was out, innocently looking on the paviers at work, saw a broken place that they had not repaired, and mentioned it to them; but they told her that Mr Guy had directed them not to go so far. Well, says she, do you mend it; tell him I bade you, and I know he will not be angry. It happened, however, that the poor girl presumed too much on her influence over her careful lover, with whom a few extraordinary shillings expence turned the scale totally against her: the men obeyed; Guy was enraged to find his orders exceeded, his matrimonial scheme was renounced, and so he built hospitals in his old age. In the year 1707 he built and furnished three wards on the north side of the outer court of St Thomas's Hospital in Southwark, and gave 100*l.* to it annually for eleven years preceding the erection of his own hospital: and, some time before his death, erected the stately iron gate, with the large houses on each side, at the expence of about 3000*l.* He was 76 years of age when he formed the design of building the hospital contiguous to that of St Thomas's, which bears his name, and lived to see it roofed in, dying in the year 1724. The charge of erecting this vast pile amounted to 18,793*l.* and he left 219,499*l.* to endow it; a much larger sum than had ever been dedicated to charitable uses in this kingdom by any one man. He erected an almshouse with a library, at Tanworth in Staffordshire (the place of his mother's nativity, and for which he was representative in parliament) for 14 poor men and women; and for their pensions, as well as for the putting out poor children apprentices, bequeathed 125*l.* a-year. Lastly, he bequeathed 1000*l.* to every one who could prove themselves in any degree related to him.

GUY, a rope used to keep steady any weighty body whilst it is hoisting or lowering, particularly when the ship is shaken by a tempestuous sea.

GUY is likewise a large slack rope, extending from the head of the main mast to the head of the fore-mast, and having two or three large blocks, fastened to the middle of it. This is chiefly employed to sustain the tackle used to hoist in and out the cargo of a merchant ship, and is accordingly removed from the mast-head as soon as the vessel is laden or delivered.

Guy's Cliff, in Warwickshire, a great cliff on the west side of the Avon and the north side of Warwick, where in the Britons time was an oratory, and in that of the Saxons an hermitage, where Guy earl of War-

Guy,
Guy's Cliff.

Guy's Cliff wick, who is said to have retired to it after his fatigues by the toils and pleasures of the world, built a chapel, and cohabited with the hermit; and that from thence it had the name. This hermitage was kept up to the reign of Henry VI. when Rich. Beauchamp, earl of Warwick, established a chantry here, and in memory of the famous Guy erected a large statue of him in the chapel eight feet in height, and raised a roof over the adjacent springs. The chapel is in the parish of St Nicholas, in the suburbs of Warwick.

GUYON, JOHANNA MARY BOURIERS DE LA MOTHE, a French lady, memorable for her writings, and for her sufferings in the cause of Quietism, was descended from a noble family, and born at Montargis in 1648. She gave some extraordinary symptoms of illumination from her earliest infancy, and tried to take the veil before she was of age to dispose of herself; but her parents obliged her to marry a gentleman to whom they had promised her. She was a widow at the age of 28; when distinguishing herself in, and making many converts to, the way of contemplation and prayer known by the name of *Quietism*, complaints were made of her spiritualism, and she was confined by order of the king, and severely examined for eight months. She was discharged; but was afterwards involved in the persecution of the archbishop of Cambrai, and thrown into the Bastille, where she underwent many examinations: but nothing being made out against her, she once more obtained her liberty, and lived private to her death in 1717. She spent her latter years in mystical reveries; covering her tables, ceilings, and every thing that would receive them, with the sallies of a visionary imagination. Her pious verses were collected after her death in 5 vols. entitled *Cantiques spirituels, ou d'Emblemes sur l'Amour Divin*. Her publications were, *Le moyen court et très facile de faire Oraisons*; and *Le Cantique des Cantiques de Salomon interprete selon le sens mystique*; which were condemned by the archbishop of Paris.

GUYTON DE MORVEAU, L. B. a late celebrated French chemist. See SUPPLEMENT.

GUZ, an Indian measure which varies in different places, but is in general equal to a yard of English measure. The guz of Akbar did not exceed 41 fingers.

GWINIAD. See SALMO, ICHTHYOLOGY *Index*.

GYARUS, in *Ancient Geography*, one of the Cyclades, 12 miles in compass, lying to the east of Delos. It was a desert island, and allotted for a place of banishment by the Romans.

GYBING, the act of shifting any boom-sail from one side of the mast to the other.

In order to understand this operation more clearly, it is necessary to remark, that by a boom-sail is meant any sail whose bottom is extended by a boom, the fore-end of which is hooked to its respective mast, so as to swing occasionally on either side of the vessel, describing an arch, of which the mast will be the centre. As the wind or the course changes, it also becomes frequently necessary to change the position of the boom, together with its sail, which is accordingly shifted to the other side of the vessel as a door turns upon its hinges. The boom is pushed out by the effort of the wind upon the sail, and is restrained in a proper situation by a strong tackle communicating with the vessel's stern.

GYGÆUS, in *Ancient Geography*; called also Co-

loss; a lake of Lydia, distant 40 stadia, or five miles, from Sardis.

GYGES, in fabulous history, a Lydian, to whom Candaules king of the country showed his wife naked. The queen was so incensed at this instance of imprudence and infirmity in her husband, that she ordered Gyges either to prepare for death himself, or to put Candaules to death. He chose the latter; and, marrying the queen, ascended the vacant throne about 718 years before the Christian era. He was the first of the Mermaidæ who reigned in Lydia. He reigned 38 years, and distinguished himself by the immense presents which he made to the oracle of Delphi (*Herod. i. c. 8.*)—According to Plato, Gyges descended into a chasm of the earth, where he found a brazen horse, whose sides he opened, and saw within the body the carcass of a man of uncommon size, from whose finger he took a brazen ring. This ring, when he put it on his finger, rendered him invisible; and by means of its virtue he introduced himself to the queen, murdered her husband, and married her and usurped the crown of Lydia. (*Cic. Oss. iii. c. 9.*)

GYMNASIARCH, in antiquity, the director of the gymnasium. He had two deputies under him; the one called *xystarck*, who presided over the athletes, and had the oversight of wrestling; the other was *gymnastes*, who had the direction of all other exercises.

GYMNASIUM, in Grecian antiquity, a place fitted for performing exercises of the body, &c.—The word is Greek, formed of *γυμνος*, "naked;" by reason they anciently put off their clothes, to practise with the more freedom.

Gymnasia, according to Potter, were first used at Lacedæmon, but were afterwards very common in all parts of Greece; and imitated, very much augmented, and improved, at Rome. There were three principal gymnasia at Athens; the academy where Plato taught; the Lyceum, noted for Aristotle's lectures; and the Cynosarges, allotted for the populace.

Vitruvius describes the structure and form of the ancient gymnasia, lib. v. cap. 11. They were called *gymnasia*, because several of the exercises were performed naked; and *palæstra*, from wrestling, which was one of the most usual exercises there: the Romans sometimes also called them *thermae*, because the baths and bagnios made a principal part of the building.—It appears that they did not perform their exercises quite naked so early as the time of Homer, but always in drawers; which they did not lay aside before the 32d Olympiad. One Orsippus is said to have been the first who introduced the practice; for having been worsted by means of his drawers undoing and entangling him, he threw them quite aside, and the rest afterwards imitated him. They were not single edifices, but a knot of buildings united, being sufficiently capacious to hold many thousands of people at once; and having room enough for philosophers, rhetoricians, and the professors of all other sciences to read their lectures,—and wrestlers, dancers, and all others who had a mind to exercise,—at the same time without the least disturbance or interruption. They consisted of a great many parts. Vitruvius recites no less than 12, viz. 1. The exterior porticoes, where the philosophers, rhetoricians, mathematicians, physicians, and other virtuosi, read public lectures, and where they also disputed and re-

heard

heard their performances. 2. The ephebeum, where the youth assembled very early, to learn their exercises in private, without any spectators. 3. The coryceum, apodyterion, or gymnasterion, a kind of wardrobe, where they stripped, either to bathe or exercise. 4. The elæothesium, alipterion, or unctuarium, appointed for the unctions, which either preceded or followed the use of the bath, wrestling, pancratia, &c. 5. The conisterium or conistra, in which they covered themselves with sand or dust, to dry up the oil or sweat. 6. The palæstra, properly so called, where they practised wrestling, the pugillate, pancratia, and divers other exercises. 7. The sphaeristerium or tennis-court, reserved for exercises wherein they used balls. 8. Large unpaved alleys, which comprehended the space between the porticoes and the walls wherewith the edifice was surrounded. 9. The xysti, which were porticoes for the wrestlers in winter or bad weather. 10. Other xystis or open alleys, allotted for summer and fine weather, some of which were quite open, and others planted with trees. 11. The baths, consisting of several different apartments. 12. The stadium, a large space of a semicircular form, covered with sand, and surrounded with seats for the spectators.

For the administration of the gymnasia, there were different officers: the principal were, 1. The gymnasiarcha, who was the director and superintendant of the whole. 2. The xystarcha, who presided in the xystus or stadium. 3. The gymnasta, or master of the exercises, who understood their different effects, and could accommodate them to the different complexions of the athletes. 4. The pædotriba, whose business was mechanically to teach the exercises, without understanding their theory or use. Under these four officers were a number of subalterns, whose names distinguished their different functions.

The gymnastic exercises may be reduced to two general classes; as they depend either on the action of the body alone, or as they require external agents or instruments. The latter consisted chiefly in mounting the horse, driving the chariot, and swimming. The former were chiefly of two kinds; orchestice, and pæstrice.

The orchestice comprehended, 1. Dancing. 2. Cuhistic, or the art of tumbling. 3. Sphaeristic or tennis, including all the exercises with pilsæ or balls.

The pæstrice comprised all exercises under the denomination *pæstricæ*; as wrestling, hexing, pancratia, hoplomachia, running, leaping, throwing the discus, the exercise of the javelin, and that of the hoop, denominated by the Greeks *σφαίρα*, which consisted in rolling an iron hoop five or six feet in diameter, beset with iron rings, the noise of which apprising the people to give way, afforded them also an amusement. Both strength and skill were requisite in directing this hoop, which was to be driven with an iron rod. To these must also be added the exercises belonging to the medicinal gymnastics; as, 1. Walking. 2. Vociferation, or shouting. 3. Holding one's breath. Hoffman enumerates no fewer than 55 sorts of exercises that were practised in the gymnasia.

GYMNASTICS, GYMNASTICE, or the GYMNAS TIC art, denotes the art of performing exercises of the body, whether for defence, health, or diversion. See GYMNASIUM.

Several modern writers have treated of this art. M. Burette has given the history of gymnastics in the Memoirs of the Royal Academy of Inscriptions.

On the first establishment of society, men, being apprised of the necessity of military exercises for repelling the insults of their neighbours, instituted games and proposed prizes to animate their youth to combats of divers kinds. And as running, leaping, strength and dexterity of arm in throwing the javelin, driving a ball, or tossing a quoit, together with wrestling, &c. were exercises suited to the manner of fighting in those days; so the youth vied to excel in them, in the presence of the aged, who sat as their judges, and dispensed prizes to the conquerors; till what was originally only amusement, became at length a matter of such importance, as to interest great cities and entire nations in its practice. Hence arose an emulation and eagerness to excel, in hopes, one day, of being proclaimed and crowned conquerors in the public games, which was the highest honour a mortal could arrive at: nay, they went so far as to imagine, that even gods and demigods were not insensible of what men were so captivated with; and, in consequence hereof, to introduce the greatest part of these exercises into their religious ceremonies, the worship of their gods, and the funeral honours done to the manes of the dead.

Though it be hard to determine the precise epocha of the gymnastic art, yet it appears from several passages in Homer, and particularly the 23d book of the Iliad, where he describes the games celebrated at the funeral of Patroclus, that it was not unknown at the time of the Trojan war. From that description, which is the earliest monument now extant of the Grecian gymnastics, it appears, that they had chariot-races, boxing, wrestling, foot-races, gladiators, throwing the discus, drawing the bow, and hurling the javelin; and it should seem from the particular account Homer gives of these exercises, that even then the gymnastic art wanted little of perfection: so that when Galen says there was no gymnastic art in Homer's days, and that it began to appear no earlier than Plato, he is to be understood of the medicinal gymnastics only. This last, indeed, had its rise later; because, while men continued sober and laborious, they had no occasion for it; but when luxury and idleness had reduced them to the sad necessity of applying to physicians, these, who had found that nothing contributed so much to the preservation and re-establishment of health as exercises, proportioned to the different complexions, ages, and sexes, did not fail to refer them to the practice of gymnastics.

According to Plato, one Herodicus, prior a little time to Hippocrates, was the first who introduced this art into physic; and his successors, convinced by experience of its usefulness, applied themselves in earnest to improve it. Hippocrates, in his book of Regimen, has given instances of it, where he treats of exercise in general, and of the particular effects of walking, with regard to health; also of the different sorts of races, either on foot or horseback; leaping, wrestling, the exercise of the suspended ball, called *corycus*, chironomy, unctions, frictions, rolling in the sand, &c. But as physicians did not adopt all the exercises of the gymnastic art in their practice, it came to be divided between them and the masters of martial and athletic exercises, who kept schools, the number of which was

Gymna-
stics
||
Gymnoso-
phists.

greatly increased in Greece. At length the Romans also caught the same taste; and, adopting the military and athletic exercises of the Greeks, they improved and advanced them to the utmost pitch of magnificence, not to say extravagance. But the declension of the empire involved the arts in its ruin, and, among others, gymnastics and medicine; which last unhappily then relinquished the title it had to the former, and has neglected to resume it ever since.

GYMNOPYRIS, in *Natural History*, an old name given to some species of pyrites. See **PYRITES**, **MINERALOGY Index**.

GYMNOSOPHISTS, a set of Indian philosophers, famous in antiquity; so denominated from their going barefoot. The word is formed of the Greek *γυμνοσοφιστης*, q. d. a sophist or philosopher who goes naked.

This name was given to the Indian philosophers, whom the excessive heat of the country obliged to go naked; as that of *Peripatetics* was given to those who philosophised walking. The Gymnosophists, however, did not go absolutely naked; but only clothed themselves no farther than modesty required. There were some of these sages in Africa; but the most celebrated clan of them was in India. The African gymnosophists dwelt upon a mountain in Ethiopia, near the Nile, without the accommodation either of house or cell. They did not form themselves into societies like those of India; but each had his private recess, where he studied and performed his devotions by himself. If any person had killed another by chance, he applied to these sages for absolution, and submitted to whatever penances they enjoined. They observed an extraordinary frugality, and lived only upon the fruits of the earth. Lucan ascribes to these Gymnosophists several new discoveries in astronomy.

As to the Indian Gymnosophists, they dwelt in the woods, where they lived upon the wild products of the earth, and never drank wine nor married. Some of them practised physic, and travelled from one place to another; these were particularly famous for their remedies against barrenness. Some of them, likewise, pretended to practise magic, and to foretel future events.

In general, the Gymnosophists were wise and learned men: their maxims and discourses, recorded by historians, do not in the least savour of a barbarous education; but are plainly the result of great sense and deep thought. They kept up the dignity of their character to so high a degree, that it was never their custom to wait upon any body, not even upon princes themselves. They believed the immortality and transmigration of the soul: they placed the chief happiness of man in a contempt of the goods of fortune, and the pleasures of sense, and gloried in having given faithful and disinterested counsels to princes and magistrates. It is said, that when they became old and infirm, they threw themselves into a pile of burning wood, in order to prevent the miseries of an advanced age. One of them, named *Calanus*, thus burnt himself in the presence of Alexander the Great.

Apuleius* describes the Gymnosophists thus: "They are all devoted to the study of wisdom, both the elder masters and the younger pupils; and what to me appears the most amiable thing in their character is, that

they have an aversion to idleness and indolence: accordingly, as soon as the table is spread, before a bit of victuals be brought, the youths are all called together from their several places and offices, and the masters examine them what good they have done since the sunrise: here one relates something he has discovered by meditation; another has learned something by demonstration; and as for those who have nothing to allege why they should dine, they are turned out to work fasting."

The great leader of the Gymnosophists, according to Jerome, was one Buddas, called by Clemens *Butta*, who is ranked by Suidas among the Brachmans. That last author makes Buddas the preceptor of Manes the Persian, the founder of the Gymnosophists.

GYMNOSPERMIA, in *Botany*, (from *γυμνος*, "naked," and *σπέρμα*, "seed;") the first order in Linnæus's class of didynamia. It comprehends the plants of that class which have naked seeds. The seeds are constantly four in number, except in one genus, viz. *phryma*, which is monospermous. See **BOTANY**, p. 65. and 211.

GYMNOTUS, a genus of fishes belonging to the order of apodes. See **ICHTHYOLOGY Index**.

GYNÆCEUM, among the ancients, the apartment of the women, a separate room in the inner part of the house, where they employed themselves in spinning, weaving, and needle-work.

GYNÆCOCRACY, denotes the government of women, or a state where women are capable of the supreme command. Such are Britain and Spain.

GYNÆOCRATUMENI, an ancient people of Sarmatia Europæa, inhabiting the eastern banks of the river Tanais, near its opening into the Palus Mæotis; thus called, as authors relate, because they had no women among them; or rather because they were under the dominion of women. The word is formed of *γυν*, *woman*, and *καταρτυμενος*, *vanquished*, of *καταρτυω*, *I overcome*, q. d. overcome by women.

Fa. Hardouin, in his notes on Pliny, says, they were thus called, because, after a battle which they lost against the Amazons, on the banks of the Thermoodon, they were obliged to have venereal commerce with them, in order to get them children; *et quid victricibus obsequantur ad procurandam eis sobolem*.—Hardouin calls them the husbands of the Amazons, *Amazonum connubia*; for, as the author observes, the word *unde* must be retrenched from Pliny, having been foisted into the text by people who were not masters of the author's meaning, *unde Amazonum connubia*. See **AMAZONS**. They who take the Amazons for a fabulous people, will conclude the same of the Gynæocratumenians.

GYNANDRIA, (from *γυν*, a "woman;" and *ανδρ*, a "man.") the name of the 20th class in Linnæus's sexual system, consisting of plants with hermaphrodite flowers, in which the stamina are placed upon the style, or pillar-shaped receptacle resembling a style, which rises in the middle of the flower, and bears both the stamina and stigma; that is, both the supposed organs of generation. See **BOTANY**, p. 65.

The flowers of this class, says Linnæus, have a monstrous appearance, arising, as he imagines, from the singular and unusual situation of the parts of fructification.

Gymnoso-
phists
||
Gynandria.

* Florid.
lib. I.

Gypses.

Gypses.

GYPSIES, or EGYPTIANS, an outlandish tribe of vagabonds, who disguising themselves in uncouth habits, smearing their faces and bodies, and framing to themselves a canting language, wander up and down, and, under pretence of telling fortunes, curing diseases, &c. abuse the common people, trick them of their money, and steal all that they can come at.

They are a strange kind of commonwealth among themselves of wandering impostors and jugglers, who made their first appearance in Germany about the beginning of the 16th century. Munster, it is true, who is followed and relied upon by Spelman, fixes the time of their first appearance to the year 1417: but as he owns that the first whom he ever saw were in 1529, it is probably an error of the press for 1517; especially as other historians inform us, that when Sultan Selim conquered Egypt in the year 1517, several of the natives refused to submit to the Turkish yoke, and revolted under one Zinganeus; whence the Turks call them Zinganees; but being at length surrounded and banished, they agreed to disperse in small parties all over the world, where their supposed skill in the black art gave them an universal reception in that age of superstition and credulity. In the compass of a very few years they gained such a number of idle proselytes (who imitated their language and complexion, and betook themselves to the same arts of chiromancy, begging, and pilfering), that they became troublesome, and even formidable, to most of the states of Europe.—Hence they were expelled from France in the year 1560, and from Spain in 1591. And the government of England took the alarm much earlier; for in 1530 they are described by Stat. 22 Hen. VIII. c. 10. as “an outlandish people calling themselves Egyptians, using no craft nor feat of merchandise, who have come into this realm, and gone from shire to shire, and place to place, in great companies, and used great, subtle, and crafty means to deceive the people; bearing them in hand that they by palmistry could tell men’s and women’s fortunes; and so many times by craft and subtlety have deceived the people of their money, and also have committed many heinous felonies and robberies.” Wherefore they are directed to avoid the realm, and not to return under pain of imprisonment, and forfeiture of their goods and chattels; and upon their trials for any felony which they may have committed, they shall not be entitled to a jury *de medietate linguæ*. And afterwards it is enacted, by statutes 1st and 2d Ph. and Mary, c. 4. and 5th Eliz. c. 20. that if any such persons shall be imported into the kingdom, the importer shall forfeit 40l. And if the Egyptians themselves remain one month in the kingdom, or if any person being 14 years old, whether natural-born subject or stranger, which hath been seen or found in the fellowship of such Egyptians, or which hath disguised him or herself like them, shall remain in the same one month at one or several times, it is felony without benefit of clergy. And Sir M. Hale informs us, that at one Suffolk assizes no less than 13 persons were executed upon these statutes a few years before the Restoration. But, to the honour of our national humanity, there are no instances more modern than this of carrying these laws into practice; and the last sanguinary act is itself now repealed by 23 Geo. III. c. 54.

In Scotland they seem to have enjoyed some share

of indulgence; for a writ of privy seal, dated 1594, supports John Faw, lord and earl of Little Egypt, in the execution of justice on his company and folk, conform to the laws of Egypt, and in punishing certain persons there named who rebelled against him, left him, robbed him, and refused to return home with him. James’s subjects are commanded to assist in apprehending them, and in assisting Faw and his adherents to return home. There is a like writ in his favour from Mary queen of Scots 1553, and in 1554 he obtained a pardon for the murder of Nuran Small. So that it appears he had staid long in Scotland, and perhaps some of the time in England; and from him this kind of strolling people might receive the name of *Faw Gang*, which they still retain.

A very circumstantial account of this singular race of vagrants has been lately given in an express *Inquiry* concerning them, written in German by H. M. G. Grellman, and translated by Mr Raper. It is incredible to think how this regular swarm of banditti has spread itself over the face of the earth. They wander about in Asia, in the interior parts of Africa, and like locusts have overrun most of the European nations. In the reigns of Henry VIII. and Queen Elizabeth, as we have seen, they were set up as a mark of general persecution in England; yet their numbers do not appear to have much diminished. Spain is supposed by Mr Twiss to contain 40,000 of these vagrants; but by others 60,000; and by some even double that number. They are less numerous in France in consequence of the strictness of the police. In Italy they abound, especially in the dominions of the church, on account of the bad police and the prevalence of superstition, which permit and entice them to deceive the ignorant. They are scattered, though not in great numbers, through Germany, Denmark, Sweden, and Russia; but their chief population is in the south-east parts of Europe, which seem to be the general rendezvous of the gypsy nation. At a moderate computation Europe contains more than seven hundred thousand of these vagabonds.—For near four centuries they have wandered through the world; and in every region, and among every people, whether barbarous or civilized, they have continued equally unchanged by the lapse of time, the variation of climate, and the force of example. Their singular physiognomy and particular manners are the same in every country.—Their swarthy complexion receives no darker shade from the burning sun of Africa, nor any fairer tincture from the temperate climates of Europe: they contract no additional laziness in Spain, nor acquire any new industry in England; in Turkey they behold the mosque and the crescent with equal indifference as they do the reformed and the catholic church in Europe. In the neighbourhood of civilized life they continue barbarous; and, beholding around them cities and settled inhabitants, they live in tents or holes in the earth, and wander from place to place as fugitives and vagabonds.

They are passionately fond of ornaments; in which however they consult neither propriety nor consistency; they will wear an old laced coat, while the rest of their garments scarcely hang together. In Hungary and Transylvania their summer habitations are tents; their winter ones holes 10 or 12 feet deep in the earth, except

Gypsies. cept such as keep inns, or exercise trades. They are fond of plate, particularly silver cups, which they bury under the hearth for security. Their principal occupations are, smith's work, or tinkers, or wooden ware, and horse-dealing; and in Hungary and Transylvania they are executioners of criminals, slayers of dead beasts, and washers of gold. The women deal in old clothes, prostitution, wanton dances, and fortune-telling. Notwithstanding these occupations the majority of this people are lazy, beggars, and thieves. They bring up their children to their own professions, and are very fond of them. They have few disorders, except the measles and smallpox, and weakness in their eyes, occasioned by the smoke; and live to an advanced age, with a strong attachment to life. Their physis is saffron in their soups, or bleeding.

These people, however, appear to be distinguished by different singularities in different countries. At least in the following circumstances the German gypsies differ widely from those we commonly meet with in England. It is a great feast to them, our author says, whenever they can procure a roast of cattle that died of any distemper. It is all one to them, whether it be carrion of a sheep, hog, cow, or other beast, horse-flesh only excepted; they are so far from being disgusted with it, that to eat their fill of such a meal, is to them the height of epicurism. When any one censures their taste, or shows surprise at it, they answer, "The flesh of a beast which God kills, must be better than of one killed by the hand of man." They therefore take every opportunity of getting such dainties. That they take carrion from a laystall, as is affirmed of the gypsies in Hungary, is by no means certain, any more than that they eat horse-flesh. But if a beast out of a herd dies, and they find it before it becomes rotten and putrified, or if a farmer gives them notice of a cow dead, they proceed, without hesitation, to get possession of this booty. Their favourite object is animals that have been destroyed by fire; therefore, whenever a conflagration has happened, either in town or country, the next day the gypsies, from every neighbouring quarter, assemble and draw the suffocated half-consumed beasts out of the ashes. Men, women, and children, in troops, are extremely busy, joyfully carrying the flesh home to their dwelling-places; they return several times, provide themselves plentifully with this roast meat, and gluttonize in their huts as long as their noble fare lasts.

The gypsies have, at least in Transylvania, a sort of regular government, rather nominal than real or effective. They have their leaders or chiefs, whom they distinguish by the Slavonian title, *Waywode*. To this dignity every person is eligible who is of a family descended from a former waywode; but the preference is generally given to those who have the best clothes and the most wealth; who are of a large stature, and not past the meridian of life.—Of religion, however, they have no sense; though, with their usual cunning and hypocrisy, they profess the established faith of every country in which they live. They also speak the languages of the respective countries, yet have a language of their own; from whence derived, authors differ. The only science which they have attained is music. Their poetry is ungrammatical indecent rhyme.

Their general character and capacities are thus de-

Gypsies. scribed: Imagine people of a childish way of thinking; their minds filled with raw, undigested conceptions; guided more by sense than reason; using understanding and reflection so far only as they promote the gratification of any particular appetite; and you have a perfect sketch of the gypsies character. They are lively, uncommonly loquacious and chattering; fickle in the extreme, consequently inconstant in their pursuits; faithless to every body, even their own cast; void of the least emotion of gratitude, frequently rewarding benefits with the most insidious malice. Fear makes them slavishly compliant when under subjection; but having nothing to apprehend, like other timorous people, they are cruel. Desire of revenge often causes them to take the most desperate resolutions. To such a degree of violence is their fury sometimes excited, that a mother has been known, in the excess of passion, to take her little infant by the feet, and with it strike the object of her anger, when no other instrument has readily presented itself. They are so addicted to drinking, as to sacrifice what is most necessary to them, that they may feast their palate with spirits. They have, too, what one would little expect, an enormous share of vanity, which shows itself in their fondness for fine clothes, and their gait and deportment when dressed in them. One might imagine, that this pride would have the good effect to render a gypsy cautious not to be guilty of such crimes as subject him to public shame; but here comes in the levity of character, for he never looks to the right nor to the left in his transactions. In an hour's time he forgets that he is just untied from the whipping post. But their pride is grounded on mere idle conceit, as appears plainly from their making it a point of honour to abuse their companions, and put on a terrible appearance in the public market, where they are sure to have many spectators; they cry out, make a violent noise, challenge their adversary to fight, but very seldom any thing comes of it. Thus the gypsy seeks honour, of which his ideas coincide very little with those of other people, and sometimes deviate entirely from propriety.

"Nothing (continues our author) can exceed the unrestrained depravity of manners existing among these people, I allude particularly to the other sex. Unchecked by any idea of shame, they give way to every desire. The mother endeavours, by the most scandalous arts, to train up her daughter for an offering to sensuality; and *this* is scarce grown up before she becomes the seducer of others. Laziness is so prevalent among them, that were they to subsist by their own labour only, they would hardly have bread for two of the seven days in the week. This indolence increases their propensity to stealing and cheating, the common attendants on idleness. They seek to avail themselves of every opportunity to satisfy their lawless desires. Their universal bad character therefore for fickleness, infidelity, ingratitude, revenge, malice, rage, depravity, laziness, knavery, thievishness, and cunning, though not deficient in capacity and cleverness, render these people of no use in society, except as soldiers to form marauding parties. Persons in their company, and under their disguise, have formed dangerous designs against cities and countries. They have been banished from almost all civilized states, in their turn, except Hungary and Transylvania, and to little purpose." Our author is of

opinion,

Gypsies. opinion, that as Turkey would allow them toleration, it would be better for the European states to take some steps for cultivating and civilizing them, and making them useful. But while they are insensible of religion and strongly attached to their own manners, it is to be feared the attempt will be impracticable. This appears from a very intelligent Hungarian lady's experience on the subject, communicated in a letter as follows: 'There are a great number of them on my estates, but I have permitted two families in particular to establish themselves at the place of my own residence, under the express condition that no others shall come here and join them. I took all possible pains to make them reasonable creatures. I set the elder ones to work; the younger ones tend the cattle. I observed that they were more fond of horses than any thing else; for which reason I placed a gypsy under each groom. I had their children clothed, that none of them might be running about naked, according to their usual practice. It appeared, however, that custom was become nature with them. The old ones worked diligently so long as any body stood over them; the moment their backs were turned, they all got together in a circle, their legs across, facing the sun, and chattered. Thus they cannot possibly earn more, indeed hardly so much, as would find them bread, although very cheap with us; for the bread I give them does not stand me in half a kreutzer the pound. Even in winter they cannot bear a hat on their head or shoes on their feet. The boys run like wild things wherever they are sent, either on foot or on horseback; but they spoil horses unmercifully, beat them on the head, jerk the bits in their mouths, so as to make them run down with blood. They cannot be brought by any means whatever to dress horses. Clothe them as you will, they always sell or lose their clothes. In a word, one cannot but consider them as void of reason; it is really shocking to see even well grown children put whatever they find into their mouths, like infants before they can speak; wherefore they eat every thing, even carrion, let it stink never so much. Where a mortality happens among the cattle, there these wretched beings are to be found in the greatest numbers.'

The origin of this people, as we have seen, has been generally believed to be Egyptian; and that belief is as old as their existence in Europe. Thomasius, Salmon the English geographer, and lately Signior Griseolini, have endeavoured to prove it by satisfactory evidence. This theory, however, according to our author, is without foundation. The Egyptian descent of these people, he thinks, is not only destitute of proofs, but the most positive evidence is found to contradict it. Their language differs entirely from the Coptic; and their customs are very different from those of the Egyptians. They are indeed to be found in Egypt; but they wander about there as strangers, and form a distinct people, as in other countries. The expressions of Bellonius are strong and decisive: "No part of the world, I believe, is free from those banditti, wandering about in troops, whom we by mistake call *Egyptians* and *Bohemians*. When we were at Cairo, and in the villages bordering on the Nile, we found troops of these strolling thieves sitting under palm trees; and they are esteemed foreigners in Egypt as well as among us."

Egyptian. The Egyptian descent of the gypsies being rejected, our author next endeavours to show that they come from Hindostan. The chief basis of his theory, however, is no other than that very dubious one, a similarity of language. He adds a long vocabulary of the gypsy and the Hindostanic languages; in which, it must be confessed, many words are the same; but many are different. A principal proof which he adduces on this head is from the relation of Captain Szekely von Doba, to whom a printer in 1763 related, that a preacher of the Reformed church, when a student at Leyden, being intimately acquainted with three young Malabar students, took down 1000 of their words, which he fancied corresponded with the gypsy language; and they added, that a tract of land in their island was named *Ozigama*. He repeated these words to the Raber gypsies, who explain them without trouble or hesitation. This account was published in the Vienna Gazette. Supposing these three young men to be sons of Bramins, who use the Sanscrit, the common language of Hindostan comes as near to that as modern Italian to pure Latin. The comparison of the two languages takes up above 30 pages; and Mr Grellman thinks it establishes his system. The same opinion is maintained by Mr Marsden, in a paper upon this subject in the 7th volume of the *Archeologia*. The numerals, however, both in Hindostanic and gypsy, differ greatly as stated by the two authors. And here, as in other such comparisons, one is astonished at the credulity of the comparers of orthoepy and orthography (as a periodical critic observes), which can have no connection in languages with which we are not perfectly familiar, even were both languages reduced to writing by their respective people: how much less, then, where one of the two languages is never reduced to writing, as is the case of the gypsy, but it is blended with the language of the country where the clan resides? This appears from the correspondence of several words in all languages with the gypsy. Mr Grellman acknowledges the two gypsy versions of the Lord's Prayer, at different periods, differ so widely, that one would almost be inclined to doubt whether they were really the same language. We think we can discern a few words differently indeed written, but probably pronounced alike. Nor can we, in all the languages in which Chamberlayne gives the Lord's Prayer, perceive the least resemblance to the gypsy name of father, *Dade* and *Dud*, except in the Welsh, *Taad*. In prosecuting his argument, Mr Grellman does not insist on the similarity of colour between the two people, nor on the cowardice common to both, nor on the attachment of the Indians to tents, or letting their children go naked; all these being traits to be met with in other nations: but he dwells on the word *Polgar*, the name of one of the first gypsy leaders, and of the Hindostanic god of marriage; also on the correspondence between the travelling smiths in the two people, who carry two pair of bellows; the Indian's boy blows them in India, the wife or child of the gypsy in Europe: as if every travelling tinker, in every nation where tinkers travel, had not the same journeymen. In lascivious dances and chiromancy the two people agree; nor are these uncommon in other parts of the globe. The excessive loquacity of the two people is produced as similar; as if no other nations in the world were loquacious. Fainter resemblances are, a fondness

Gypsies. for saffron, and the intermarrying only with their own people. The last position in the author's theory is, that the gypsies are of the lowest class of Indians, namely, *Perias*, or, as they are called in Hindostan, *Suders*. He compares the manners of this class with those of the gypsies, and enumerates many circumstances in which they agree: some of the comparisons are frivolous, and prove nothing. As an instance of which we may take the following: 'Gypsies are fond of being about horses; the *Suders* in India likewise, for which reason they are commonly employed as horse-keepers by the Europeans resident in that country.' This reasoning does not prove that the gypsies are *Suders*, any more than that they are Arabians or Yorkshire farmers.

The objections, however, to which this learned and industrious author's theory is liable, are such as only show it to be by no means satisfactory; but do not prove that it is wrong. It may possibly be right; and upon this supposition the cause of their emigration from their country, he conjectures, not without probability, to be the war of Timur Beg in India. In the years 1408 and 1409 this conqueror ravaged India; and the progress of his arms was attended with devastation and cruelty. All who made resistance were destroyed; those who fell into the enemy's hands were

made slaves; of these very slaves 100,000 were put to death. As on this occasion an universal panic took place, what could be more natural than that a great number of terrified inhabitants should endeavour to save themselves by flight?—In the last place, the author endeavours to trace the route by which the gypsies came from Hindostan to Europe: but here he justly acknowledges that all that can be said on the subject is mere surmise; and, upon the whole, after perusing all the preceding details, the reader will probably be of opinion that there still hangs a cloud over the origin of this extraordinary race.

GYP SOPHILA, a genus of plants belonging to the decandria class; and in the natural method ranking under the 22d order, *Caryophyllei*. See *BOTANY Index*.

GYP SUM, PLASTER-STONE, or Alabaster. See *GYP SUM, MINERALOGY Index*.

GYR-FALCO, the name of a large and fierce species of falcon, called in English the *jer-falcon*. See *ORNITHOLOGY Index*.

GYRINUS, a genus of insects of the *Coleoptera* order. See *ENTOMOLOGY Index*.

GYSHORN, a town of Germany, in the duchy of Lunenburgh, situated on the river Aller, in E. Long. 10. 49. N. Lat. 52. 49.

Gypsies.
Gyshorn.

H.

H THE eighth letter and sixth consonant in our alphabet; though some grammarians will have it to be only an aspiration, or breathing. But nothing can be more ridiculous than to dispute its being a distinct sound, and formed in a particular manner by the organs of speech, at least in our language: witness the words *eat* and *heat*, *arm*, and *harm*, *ear*, and *hear*, *at* and *hot*, &c. as pronounced with or without the *h*.

It is pronounced by a strong expiration of the breath between the lips, closing, as it were, by a gentle motion of the lower jaw to the upper, and the tongue nearly approaching the palate.

There seems to be no doubt, that our *h*, which is the same with that of the Romans, derived its figure from that of the Hebrew *ח*. And, indeed, the Phœnicians, most ancient Greeks and Romans, used the same figure with our *H*, which in the series of all these alphabets keeps its primitive place, being the eighth letter.

H, used as a numeral, denotes 200; and with a dash over it, \overline{H} 200,000.

As an abbreviation, *H* was used by the ancients to denote *homo*, *hæres*, *hora*, &c. Thus *H. B.* stood for *hæres bonorum*; and *H. S.* corruptly for *L. L. S. sesterce*; and *H. A.* for *Hadrianus*.

HAAG, or HAG, a town of the duchy of Bavaria in Germany, seated on a hill on the west side of the river Inn, in E. Long. 12. 15. N. Lat. 48. 18.

HABAKKUK, one of the twelve lesser prophets, whose prophecies are taken into the canon of the Old

Testament. The name is written in the Hebrew with *ח* *heth*; and signifies "a wrestler." There is no precise time mentioned in Scripture when this Habakkuk lived; but from his predicting the ruin of the Jews by the Chaldeans, it may be concluded that he prophesied before Zedekiah, or about the time of Manasseh. He is reported to have been the author of several prophecies which are not extant: but those that are indisputably his, are contained in three chapters. In these the prophet complains very pathetically of the disorders which he observed in the kingdom of Judæa. God reveals to him, that he would shortly punish them in a very terrible manner by the arms of the Chaldeans. He foretels the conquests of Nebuchadnezzar, his metamorphosis, and death. He foretels, that the vast designs of Jehoiakim would be frustrated. He speaks against a prince (probably the king of Tyre) who built with blood and iniquity; and he accuses another king (perhaps the king of Egypt) of having intoxicated his friend, in order to discover his nakedness. The third chapter is a song or prayer to God, whose majesty he describes with the utmost grandeur and sublimity of expression.

HABAT, a province of Asia, in Barbary, and in the kingdom of Fez. It is surrounded by the Mediterranean, the straits of Gibraltar, and the Atlantic ocean. The principal towns are Arzilla, Tetuan, and Ceuta; which last is in possession of the Spaniards.

HABDALA, a ceremony of the Jews observed on the evening of the sabbath when every one of the family

Habakkuk.
Habdala.

Habdala,
Habeas
Corpus.

Habeas
Corpus.

mily is come home. At that time they light a taper or lamp, with two wicks at least. The master of the family then takes a cup, with some wine, mixed with fragrant spices, and having repeated a passage or two of Scripture, as for example, "I will take the cup of salvation," &c. Psal. cxvi. and "The Jews had light and gladness," &c. Esth. viii. he blesses the wine and spices. Afterwards he blesses the light of the fire; and then casts his eyes on his hands and nails, as remembering that he is going to work. The whole is intended to signify, that the sabbath is over, and is from that moment divided from the day of labour which follows. For this reason the ceremony is called *Habdala*, which signifies "distinction." After the ceremony is over, and the company breaks up, they wish one another, not "a good night," but "a good week."

HABEAS CORPUS, in Law, is the great remedy in cases of *False IMPRISONMENT*. The incapacity of the three other remedies referred to under that article, to give complete relief in every case, hath almost entirely antiquated them, and hath caused a general resource to be had, in behalf of persons aggrieved by illegal imprisonment, to the present writ, the most celebrated in the English law. Of this there are various kinds made use of by the courts at Westminster, for removing prisoners from one court into another for the more easy administration of justice. Such is the *habeas corpus ad respondendum*, when a man hath a cause of action against one who is confined by the process of some inferior court; in order to remove the prisoner, and charge him with this new action in the court above. Such is that *ad satisfaciendum*, when a prisoner hath had judgment against him in an action, and the plaintiff is desirous to bring him up to some superior court to charge him with process of execution. Such also are those *ad prosequendum*, *testificandum*, *deliberandum*, &c.; which issue when it is necessary to remove a prisoner, in order to prosecute or bear testimony in any court, or to be tried in the proper jurisdiction wherein the fact was committed. Such is, lastly, the common writ *ad faciendum et recipiendum*, which issues out of any of the courts of Westminster-hall, when a person is sued in some inferior jurisdiction, and is desirous to remove the action into the superior court; commanding the inferior judges to produce the body of the defendant, together with the day and cause of his caption and detainer (whence the writ is frequently denominated an *habeas corpus cum causa*), to do and receive whatsoever the king's court shall consider in that behalf. This is a writ grantable of common right, without any motion in court; and it instantly supercedes all proceedings in the court below. But, in order to prevent the surreptitious discharge of prisoners, it is ordered by statute 1 & 2 P. & M. c. 13. that no *habeas corpus* shall issue to remove any prisoner out of any gaol, unless signed by some judge of the court out of which it is awarded. And, to avoid vexatious delays by removal of frivolous causes, it is enacted by statute 21 Jac. L. c. 23. that, where the judge of an inferior court of record is a barrister of three years standing, no cause shall be removed from thence by *habeas corpus* or other writ, after issue or demurrer deliberately joined; that no cause, if once remanded to the inferior court by writ of *procedendo* or otherwise,

shall ever afterwards be again removed; and that no cause shall be removed at all, if the debt or damages laid in the declaration do not amount to the sum of five pounds. But an *expedient* having been found out to elude the latter branch of the statute, by procuring a nominal plaintiff to bring another action for five pounds or upwards (and then by the course of the court the *habeas corpus* removed both actions together), it is therefore enacted by statute 12 Geo. I. c. 29. that the inferior court may proceed in such actions as are under the value of five pounds, notwithstanding other actions may be brought against the same defendant to a greater amount.

But the great and efficacious writ, in all manner of illegal confinement, is that of *habeas corpus ad subjiciendum*; directed to the person detaining another, and commanding him to produce the body of the prisoner, with the day and cause of his caption and detention, *ad faciendum, subjiciendum, et recipiendum*, to do, submit to, and receive whatsoever the judge or court awarding such writ shall consider in that behalf. This is a high prerogative writ, and therefore by the common law issuing out of the court of king's bench, not only in term-time, but also during the vacation, by a *fiat* from the chief justice, or any other of the judges, and running into all parts of the king's dominions: for the king is at all times intitled to have an account why the liberty of any of his subjects is restrained, wherever that restraint may be inflicted. If it issues in vacation, it is usually returnable before the judge himself who awarded it, and he proceeds by himself thereon; unless the term should intervene, and then it may be returned in court. Indeed, if the party were privileged in the courts of common pleas and exchequer, as being an officer or suitor of the court, an *habeas corpus ad subjiciendum* might also have been awarded from thence; and, if the cause of imprisonment were palpably illegal, they might have discharged him: but if he were committed for any criminal matter, they could only have remanded him, or taken bail for his appearance in the court of king's bench; which occasioned the common pleas to discountenance such applications. It hath also been said, and by very respectable authorities, that the like *habeas corpus* may issue out of the court of chancery in vacation: but upon the famous application to Lord Nottingham by Jenks, notwithstanding the most diligent searches, no precedent could be found where the chancellor had issued such a writ in vacation; and therefore his lordship refused it.

In the court of king's bench it was, and is still, necessary to apply for it by motion to the court, as in the case of all other prerogative writs (*certiorari*, prohibition, *mandamus*, &c.) which do not issue as of mere course, without showing some probable cause why the extraordinary power of the crown is called in to the party's assistance. For, as was argued by Lord chief justice Vaughan, "it is granted on motion, because it cannot be had of course; and there is therefore no necessity to grant it; for the court ought to be satisfied that the party hath a probable cause to be delivered." And this seems the more reasonable, because, when once granted, the person to whom it is directed can return no satisfactory excuse for not bringing up the body of the prisoner. So that, if it

Blackst.
Comment.

issued

D d

Habeas
Corpus.

issued of mere course, without showing to the court or judge some reasonable ground for awarding it, a traitor or felon under sentence of death, a soldier or mariner in the king's service, a wife, a child, a relation, or a domestic, confined for insanity or other prudential reasons, might obtain a temporary enlargement by suing out an *habeas corpus*, though sure to be remanded as soon as brought up to the court. And therefore Sir Edward Coke, when chief justice, did not scruple, in 13 Jac. I. to deny a *habeas corpus* to one confined by the court of admiralty for piracy; there appearing, upon his own showing, sufficient grounds to confine him. On the other hand, if a probable ground be shown, that the party is imprisoned without just cause, and therefore hath a right to be delivered, the writ of *habeas corpus* is then a writ of right, which "may not be denied, but ought to be granted to every man that is committed, or detained in prison, or otherwise restrained, though it be by the command of the king, the privy-council, or any other."

In the articles LIBERTY and RIGHTS, will be found a full discussion of the personal liberty of the subject. This is shown to be a natural inherent right, which could not be surrendered or forfeited unless by the commission of some great and atrocious crime, and which ought not to be abridged in any case without the special permission of law; a doctrine coeval with the first rudiments of our constitution; and handed down to us from the Anglo-Saxons, notwithstanding all their struggles with the Danes, and the violence of the Norman conquest: asserted afterwards and confirmed by the conqueror himself and his descendants; and though sometimes a little impaired by the ferocity of the times, and the occasional despotism of jealous or usurping princes, yet established on the firmest basis by the provisions of *magna charta*, and a long succession of statutes enacted under Edward III. To assert an absolute exemption from imprisonment in all cases, is inconsistent with every idea of law and political society; and in the end would destroy all civil liberty, by rendering its protection impossible: but the glory of the English law consists in clearly defining the time, the causes, and the extent, when, wherefore, and to what degree, the imprisonment of the subject may be lawful. This it is which induces the absolute necessity of expressing upon every commitment the reason for which it is made: that the court, upon an *habeas corpus*, may examine into its validity; and according to the circumstances of the case may discharge, admit to bail, or remand the prisoner.

And yet, early in the reign of Charles I. the court of king's bench, relying on some arbitrary precedents (and those perhaps misunderstood), determined* that they could not upon an *habeas corpus* either bail or deliver a prisoner, though committed without any cause assigned, in case he was committed by the special command of the king, or by the lords of the privy-council. This drew on a parliamentary inquiry, and produced the *petition of right*, 3 Car. I. which recites this illegal judgment, and enacts that no freeman hereafter shall be so imprisoned or detained. But when, in the following year, Mr Selden and others were committed by the lords of the council, in pursuance of his majesty's special command, under a general charge

of "notable contempts and stirring up sedition against the king and government," the judges delayed for two terms (including also the long vacation) to deliver an opinion how far such a charge was bailable; and when at length they agreed that it was, they however annexed a condition of finding sureties for the good behaviour, which still protracted their imprisonment; the chief justice Sir Nicholas Hyde, at the same time declaring†, that "if they were again remanded for that cause, perhaps the court would not afterwards grant a *habeas corpus*, being already made acquainted with the cause of the imprisonment." But this was heard with indignation and astonishment by every lawyer present; according to Mr Selden's own account of the matter, whose resentment was not cooled at the distance of four-and-twenty years.

These pitiful evasions gave rise to the statute 16 Car. I. c. 10. § 8. whereby it is enacted, that if any person be committed by the king himself in person, or by his privy-council, or by any of the members thereof, he shall have granted unto him, without any delay, upon any pretence whatsoever, a writ of *habeas corpus*, upon demand or motion made to the court of king's bench or common pleas; who shall thereupon, within three court days after the return is made, examine and determine the legality of such commitment, and do what to justice shall appertain, in delivering, bailing, or remanding such prisoner. Yet still in the case of Jenks, before alluded to, who in 1676 was committed by the king in council for a turbulent speech at Guildhall, new shifts and devices were made use of to prevent his enlargement by law; the chief justice (as well as the chancellor), declining to award a writ of *habeas corpus ad subjiciendum* in vacation, though at last he thought proper to award the usual writs *ad deliberandum*, &c. whereby the prisoner was discharged at the Old Bailey. Other abuses had also crept into daily practice, which had in some measure defeated the benefit of this great constitutional remedy. The party imprisoning was at liberty to delay his obedience to the first writ, and might wait till a second and a third, called an *alias* and a *pluries*, were issued, before he produced the party; and many other vexatious shifts were practised to detain state-prisoners in custody. But whoever will attentively consider the English history, may observe, that the flagrant abuse of any power, by the crown or its ministers, has always been productive of a struggle; which either discovers the exercise of that power to be contrary to law, or (if legal) restrains it for the future. This was the case in the present instance. The oppression of an obscure individual gave birth to the famous *habeas corpus* act, 31 Car. II. c. 2. which is frequently considered as another *magna charta* of the kingdom; and by consequence has also in subsequent times reduced the method of proceeding on these writs (though not within the reach of that statute, but issuing merely at the common law) to the true standard of law and liberty.

The statute itself enacts, 1. That the writ shall be returned and the prisoner brought up, within a limited time according to the distance, not exceeding in any case twenty days. 2. That such writs shall be endorsed, as granted in pursuance of this act, and signed by the person awarding them. 3. That on complaint and request

Habeas
Corpus.

Ibid. 24c.

* *State Trials*, viii. 136.

Habeas
Corpus.

request in writing by or on behalf of any person committed and charged with any crime (unless committed for treason or felony expressed in the warrant, or for suspicion of the same, or as accessory thereto before the fact, or convicted or charged in execution by legal process), the lord chancellor, or any of the twelve judges in vacation, upon viewing a copy of the warrant, or affidavit that a copy is denied, shall (unless the party has neglected for two terms to apply to any court for his enlargement) award a *habeas corpus* for such prisoner, returnable immediately before himself or any other of the judges; and upon the return made shall discharge the party, if bailable, upon giving security to appear and answer to the accusation in the proper court of judicature. 4. That officers and keepers neglecting to make due returns, or not delivering to the prisoner or his agent within six hours after demand a copy of the warrant of commitment, or shifting the custody of a prisoner from one to another without sufficient reason or authority (specified in the act), shall for the first offence forfeit 100l. and for the second offence 200l. to the party grieved, and be disabled to hold his office. 5. That no person, once delivered by *habeas corpus*, shall be recommitted for the same offence, on penalty of 500l. 6. That every person committed for treason or felony shall, if he requires it the first week of the next term, or the first day of the next session of *oyer and terminer*, be indicted in that term or session, or else admitted to bail; unless the king's witnesses cannot be produced at that time: and if acquitted, or if not indicted and tried in the second term or session, he shall be discharged from his imprisonment for such imputed offence: but that no person, after the assizes shall be opened for the county in which he is detained, shall be removed by *habeas corpus*, till after the assizes are ended; but shall be left to the justice of the judges of assize. 7. That any such prisoner may move for and obtain his *habeas corpus*, as well out of the chancery or exchequer as out of the king's bench or common pleas; and the lord chancellor or judges denying the same, on sight of the warrant, or oath that the same is refused, forfeit severally to the party grieved the sum of 500l. 8. That the writ of *habeas corpus* shall run into the counties palatine, cinque ports, and other privileged places, and the islands of Jersey and Guernsey. 9. That no inhabitant of England (except persons contracting, or convicts praying to be transported; or having committed some capital offence in the place to which they are sent) shall be sent prisoners to Scotland, Ireland, Jersey, Guernsey, or any places beyond the seas, within or without the king's dominions, on pain that the party committing, his advisers, aiders, and assistants, shall forfeit to the party grieved a sum not less than 500l. to be recovered with treble costs; shall be disabled to bear any office of trust or profit; shall incur the penalties of *præmunire*; and shall be incapable of the king's pardon.

This is the substance of that great and important statute, which extends (we may observe) only to the case of commitments for such criminal charge as can produce no inconvenience to public justice by a temporary enlargement of the prisoner; all other cases of unjust imprisonment being left to the *habeas corpus* at common law. But even upon writs at the common law it is now expected by the court, agreeable to an-

cient precedents and the spirit of the act of parliament, that this writ should be immediately obeyed, without waiting for any *alias* or *pluries*; otherwise an attachment will issue. By which admirable regulations, judicial as well as parliamentary, the remedy is now complete for removing the injury of unjust and illegal confinement. A remedy the more necessary, because the oppression does not always arise from the ill nature, but sometimes from the mere inattention, of government. For it frequently happens in foreign countries, (and has happened in England during the temporary suspension of the statute), that persons apprehended upon suspicion have suffered a long imprisonment, merely because they were forgotten.

HABERDASHER, in commerce, a seller of hats and other small wares.—The master and warden of the company of haberdashers in London, calling to their assistance one of the company of cappers, and another of the hat-makers, and mayors, &c. of towns, may search the wares of all hatters who work hats with foreign wool, and who have not been apprentices to the trade, or who dye them with any thing but copperas and galls, or woad and madder; in which cases, they are liable to penalties by stat. 8 Eliz. cap. 7. and 5 Geo. II. cap. 22. See BERDASH.

HABERGION, or **HAUBERGEON**, **HABERGETUM**, a coat of mail; an ancient piece of defensive armour, in form of a coat, descending from the neck to the middle, and formed of little iron rings or meshes, linked into each other.—It is also written *haberge*, *hauberge*, *hauberc*, *haubert*, *hautber*, *hautbert*, and *hauberk*. Spelman takes it from the ancient French *haut*, "high," and *berg*, "armour, covering;" as serving to defend the upper part of the body. Du Cange and Skinner derive it from the Belgic *hals*, or Teutonic *haltz*, "neck," and *bergen*, "to cover;" i. e. a defence for the neck. Others will have it formed of *al*, *alla*, q. d. *all*, and *bergen*, "to cover;" as importing it a cover for the whole body. In Scripture it seems to signify an offensive weapon. "The sword of him that layeth at him cannot hold; the spear, the dart, nor the habergeon," Job, xli. 26.

HABIT, in *Philosophy*, an aptitude or disposition either of mind or body, acquired by a frequent repetition of the same act. See *CUSTOM and HABIT*.

HABIT is also used for a dress or garb, or the composition of garments, wherewith a person is covered. The principal part of the dress worn by the Jews and Greeks was the *imatio* and the *χιτων*. The *imatio* was an upper garment, consisting of a loose square piece of cloth wrapped round the body; the *χιτων* was an under garment, or tunic, which was fastened round the body and embraced it closely, falling down to the mid thigh. It is proper in this place to observe that a person divested of this upper garment or *imatio*, in the eastern language, is styled *naked*, and in this sense David danced naked before the ark.

The several sorts of garments in use with both sexes, amongst the Romans, were the toga, tunica, peluna, lacerna, chlamys, paludamentum, læna, stola, pallium or palla. See **TOGA**, &c.

For the habits of the priests amongst the Jews, Greeks, and Romans, see the article **PRIESTS**.

HABIT is particularly used for the uniform garments of the religious, conformable to the rule and order

Habeas
Corpus
Habit.

Habit

Hacket.

whereof they make profession; as the habit of St Benedict, of St Augustine, &c.

In this sense we say absolutely, such a person has taken the habit; meaning he has entered upon a novitiate in a certain order. So he is said to quit the habit, when he renounces the order. See VOW.

The habits of the several religious are not supposed to have been calculated for singularity or novelty: the founders of the orders, who were at first chiefly inhabitants of deserts and solitudes, gave their monks the habit usual among the country people. Accordingly, the primitive habits of St Anthony, St Hilarion, St Benedict, &c. are described by the ancient writers as consisting chiefly of sheep skins, the common dress of the peasants, shepherds, and mountaineers of that time; and the same they gave to their disciples.

The orders established in and about cities and inhabited places took the habit worn by other ecclesiastics at the time of their institution. Thus, St Dominic gave his disciples the habit of regular canons, which he himself had always worn to that time. And the like may be said of the Jesuits, Barnabites, Theatins, Oratorians, &c. who took the common habit of the ecclesiastics at the time of their foundation. And what makes them differ so much from each other, as well as from the ecclesiastical habit of the present times, is, that they have always kept invariably to the same form; whereas the ecclesiastics and laics have been changing their mode on every occasion.

HABITE and REPUTE, in *Scots Law*, the common opinion of the people, among whom a person lives, with respect to any circumstance relating to him.

HABITUDE, among schoolmen, the respect or relation one thing bears to another. See RELATION.

HABSBURG, or **HAPSBURG**, an ancient castle of Switzerland, in the canton of Bern. It is the place where the ancient counts of Hapsburg resided, and is seated near the lake of Lucern, and to the east of the town of that name. E. Long. 8. 10. N. Lat. 47. 22.

HACHA, a sea-port town of South America, in Terra Firma, seated at the mouth of a river of the same name. Here the Spanish galleons touch at their arrival in South America, from whence expresses are sent to all the settlements to give them notice of it. W. Long. 72. 46. N. Lat. 11. 28.

HACKET, JOHN, bishop of Litchfield and Coventry, was born in 1592. In 1623 he was made chaplain to James I. and prebendary of Lincoln: and soon after obtained the rectory of St Andrew's Holborn, with that of Cheam in Surrey; his patron telling him, he intended Holborn for wealth, and Cheam for health. In 1642 he was presented to a prebendary and residentiary; but was deprived of the enjoyment of them, as well as of St Andrew's, by the ensuing troubles. He then lived retired at Cheam with little disturbance, until he recovered his preferments by the restoration of Charles II. by whom he was preferred to the see of Litchfield and Coventry in 1661. Finding the beautiful cathedral of Litchfield almost battered to the ground, he in eight years finished a complete church superior to the former, at his own expence of 20,000l. excepting 1000l. he had from the dean and chapter, with what he could procure from private benefactors.

He laid out 1000l. on a prebendal house, his palaces at Litchfield and Eccleshall having been demolished during the civil wars; and beside these acts of munificence, left several other benefactions at his death in 1670. He published, before he entered into orders, a comedy entitled *Loyola*, which was twice acted before King James I. After his death there appeared a "Century of his sermons on several remarkable subjects," in folio; and "The Life of Archbishop Williams," in folio, which was abridged in 1700 by Ambrose Philips.

HACKNEY, a parish of Middlesex, on the north-east side of London, containing no less than 12 hamlets. At the bottom of Hackney-Marsh, through which the river Lea runs, between Old Ford and the Wyck, there have been discovered the remains of a great stone causeway, which, by the Roman coins, &c. found there, was no doubt one of the famous highways made by the Romans. The church here is of a very ancient foundation, so old as Edward II. That part next London is called *Marc-street*; the middle *Church-street*; and the north part *Clapton*; Dorleston and Shacklewell are on the west, and Hummerton, which leads to the Marsh, on the east. Here are three meeting-houses and several boarding-schools, besides the free-school in the church-yard, a charity-school, and 17 almshouses. It was from this place that the coaches let to the people in London first received their name; for in the 17th century, many people having gone on visits to see their friends at Hackney, it occasioned them often to hire horses or carriages, so that in time it became a common name for such hortes, coaches, and chairs, as were let to the people of London; and the name has now become general. Population 16,771.

HACKNEY-Coaches, those exposed to hire in the streets of London, and some other great cities, at rates fixed by authority. See COACH.—These first began to ply in the streets of London, or rather waited at inns, in the year 1625, and were only 20 in number; but in 1635 they were so much increased, that King Charles issued out an order of council for restraining them. In 1637, he allowed 50 hackney-coachmen, each of whom might keep 12 horses. In 1652, their number was limited to 200; and in 1654, it was extended to 300. In 1661, 400 were licensed, at 5l. annually for each. In 1694, 700 were allowed, and taxed by the 5 and 6 of W. and M. at 4l. per annum each. By 9 Anne cap. 23. 800 coaches were allowed in London and Westminster; but by 8 Geo. III. cap. 24. the number is increased to 1000, which are to be licensed by commissioners, and to pay a duty of 5s. per week to the king. On Sundays there were formerly only 175 hackney-coaches to ply, which were to be appointed by commissioners; but their number is now unlimited.

The fare of hackney-coachmen in London, or within ten miles of the city, is 12 shillings and sixpence per day, allowing 12 hours per day. By the hour it is 1s. 6d. for the first, and 1s. for every hour after; and none are obliged to pay above 1s. for any distance not exceeding a mile and a half; or above 1s. 6d. for any distance not exceeding two miles. Where hackney-coachmen refuse to go at, or exact more than, their limited hire, they are subject to a forfeit not under

Hacket
Hackney
Coaches.Such were
the fares,
&c. some
years ago.

Hackney-Coaches, Haddington.

der 10s. or exceeding 3l. and which the commissioners have power to determine. Every hackney-coach must be provided with check-strings, and every coachman plying without them incurs a penalty of 5s.— Drivers of hackney-coaches are to give way to persons of quality and gentlemen's coaches, under the penalty of 5l.

* See Revenue.

The duty arising from licences to hackney-coaches and chairs in London, forms a branch of the king's extraordinary and perpetual revenue*. This revenue is governed by commissioners of its own, and is in truth a benefit to the subject; as the expence of it is felt by no individual, and its necessary regulations have established a competent jurisdiction, whereby a very refractory race of men may be kept in tolerable order.

HADDINGTON, COUNTY OF, otherwise called *East Lothian*, is bounded by Mid Lothian on the west; on the north by the frith of Forth; on the east by the German ocean; and it is separated from the county of Berwick by the Lammermoir hills. It is about 25 miles long, and from 12 to 16 broad, being reputed one of the most fertile counties in the kingdom, producing abundance of wheat and every species of grain. Even the mountainous part of it towards the south is admirably adapted to the rearing of sheep. The inhabitants on the sea coasts employ themselves in fishing, making of salt, foreign trade, and the exportation of corn. Several branches of the linen and woollen manufacture have been established in the interior of the county, and are in a flourishing condition. There is a manufacture of sulphuric acid (oil of vitriol) established at Prestonpans, and one for sal ammoniac near the same place.

It contains three royal boroughs, viz. Haddington, North Berwick, and Dunbar; besides a number of well peopled villages and towns, such as Tranent, Prestonpans, Aberlady, Dirleton, &c. In this county also there are many seats of noblemen and gentlemen, such as those of the duke of Roxburgh, marquis of Tweeddale, earl of Haddington, Lord Blantyre, earl of Wemyss, Lord Elibank, earl of Hopetoun, Sir James Hall, Hay of Drummelzier, &c. &c. In this county there is abundance of coal of an excellent quality, of freestone and lime-stone; ironstone is found in the parish of Humbie, and in the vicinity of Stenton there are some traces of an ore of lead. It is divided into 24 parishes. The population in 1801 amounted to 29,986 souls, and in 1811 to 31,057. The following table exhibits a view of the population of this county, according to the Statistical History of Scotland.

Parishes.	Population in 1755.	Population in 1790-98.
1 Aberlady	739	800
Athelstaneford	691	927
Bolton	359	235
Dirleton	1700	1200
5 Dunbar	3281	3700
Garvald	774	730
Gladsmuir	1415	1380
Haddington	3975	3915
Humbie	1570	676
10 Innerwick	941	960

Parishes.	Population in 1755.	Population in 1790-98.
Morham	245	190
North Berwick	1412	1300
Oldhamstocks	622	498
Ormiston	810	864
15 Pencaitland	910	1033
Prestonhaugh	1318	1176
Prestonpans	1596	2028
Salton	761	830
Spot	727	619
20 Stenton	631	624
Tranent	2459	2732
Whitekirk	968	994
Whittingham	714	655
24 Yester	1091	900
	<hr/>	<hr/>
	29,709	28,966
Population in 1811	31,057	

Haddington & Hadersleben.

See HADDINGTONSHIRE, SUPPLEMENT.

HADDINGTON, a borough-town of Scotland and the capital of East Lothian, or Haddingtonshire, is situated about 16 miles east from Edinburgh, being the first stage on the London road, and in W. Long. 2. 25. N. Lat. 55. 50. It stands on the river Tyne, has four streets which are neatly built, cutting each other at right angles, with a town-house erected in 1748, from a design by the celebrated Mr Adams. The school is commodious, with lodgings for the masters, and accommodation for boarders. The parish church is large, which formerly belonged to the Franciscan monastery, and was probably built about the beginning of the 13th century. The west end is now the place of worship, for the rest of it is completely in ruins. The aisle is the burying place of the family of Maitland, and contains several marble statues of the dukes of Lauderdale. On the monument of Maitland of Thirlstane is an epitaph composed by James VI. Haddington is a place of great antiquity, for it is styled by the mother of Malcolm IV. in a charter granted in 1178, *meum Burgum de Haddington*. Its political constitution is composed of a provost, three bailies, a dean of guild, treasurer, and 12 counsellors. Its incorporated trades are seven in number. It was once strongly fortified, of which different traces are still to be seen.

A considerable manufacture of coarse woollen cloth is carried on in the town and suburbs. It has two annual fairs, and a weekly market on Friday, computed to be the greatest in Scotland for all sorts of grain. Haddington has suffered much from the ravages of fire and the inundations of the Tyne, which rose 17 feet above its usual level in the year 1775, by which one half of the town was laid under water. Here the celebrated John Knox, father of the reformation, is said to have been born, and strangers are still shown the house where he first drew his breath. It has a vote in electing a member of parliament along with North Berwick, Dunbar, Jedburgh, and Lauder. Its revenue is estimated at about 400l. sterling per annum.

HADDOCK, the English name of a species of *GADUS*. See *GADUS*, *ICHTHYOLOGY Index*.

HADERSLEBEN, a sea-port town of Denmark,

Haderpleben in the duchy of Sleswic, with a strong citadel, built upon a small island. It is seated on a bay of the Baltic sea, and has a well frequented harbour. E. Long. 9. 30. N. Lat. 55. 18.

Hæretica

HADES, in the scriptures, is used in various senses. Sometimes it signifies the invisible regions of the dead, sometimes the place of the damned, and sometimes the grave. In Greek authors it is used to signify in general the regions of the dead. See **HELL**.

HADLEY, a town of Suffolk, seated in a bottom on the river Preston. It has a handsome church, a chapel of ease, and a Presbyterian meeting-house, and had 2592 inhabitants in 1811. The streets are pretty broad, but not paved. Large quantities of yarn are spun here for the Norwich manufacture; and this town had once a considerable woollen manufacture, which is now decayed. E. Long. 1. 0. N. Lat. 52. 7.

HADRIAN. See **ADRIAN**.

HÆMAGOGOS, among physicians, a compound medicine, consisting of fetid and aromatic simples mixed with black hellebore, and prescribed in order to promote the menstrual and hæmorrhoidal fluxes; as also to bring away the lochia.

HÆMANTHUS, the **BLOOD-FLOWER**, a genus of plants belonging to the hexandria class; and in the natural method ranking under the ninth order, *Spathaceæ*. See **BOTANY Index**.

HÆMATITES, or **BLOOD-STONE**, a species of iron ore. See **MINERALOGY Index**.

HÆMATOPUS, the **SEA-PYE**, a genus of birds belonging to the order of grallæ. See **ORNITHOLOGY Index**.

HÆMATOXYLUM, **LOGWOOD**, or *Campeachy Wood*; a genus of plants belonging to the decandria class; and in the natural method ranking under the 33d order, *Lomentaceæ*. See **BOTANY Index**; and for its properties and use as a dye stuff, see **DYEING Index**.

HÆMOPTYSIS, **HÆMPTYSIS**, or *Hæmoptoe*; a spitting of blood. See **MEDICINE Index**.

HÆMORRHAGY, (compounded of *αἷμα*, "blood," and *ῥέωμι*, "I burst forth") in medicine, a flux of blood at any part of the body; arising either from a rupture of the vessels, as when they are too full or too much pressed; or from an erosion of the same, as when the blood is too sharp and corrosive.—The hæmorrhagy, properly speaking, as understood by the Greeks, was only a flux of blood at the nose; but the moderns extend the name to any kind of flux of blood, whether by the nose, mouth, lungs, stomach, intestines, fundament, matrix, or whatever part. See **MEDICINE and SURGERY Index**.

HÆMORRHOIDAL, an appellation given by anatomists to the arteries and veins going to the intestinum rectum.

HÆMORRHOIDS, or **PILES**, an hæmorrhage or issue of blood from the hæmorrhoidal vessels. See **MEDICINE Index**.

HÆMUS, in *Ancient Geography*, a vast ridge, running from Illyricum toward the Euxine, (Pliny); so high as to afford a prospect both of the Euxine and Adriatic. Here, in after ages, was constituted a province called *Hæmimons*, or *Hæmimontus*.

HÆRETICO COMBURENDO, a writ which anciently lay against an heretic, who, having once been convicted of heresy by his bishop, and having abjured it, afterwards falling into it again, or into some other, is

thereupon committed to the secular power. This writ is thought by some to be as ancient as the common law itself; however, the conviction of heresy by the common law was not in any petty ecclesiastical court, but before the archbishop himself in a provincial synod, and the delinquent was delivered up to the king to do with him as he pleased; so that the crown had a controul over the spiritual power. But by 2 Henry IV. cap. 15. the diocesan alone, without the intervention of a synod, might convict of heretical tenets; and unless the convict abjured his opinions, or if after abjuration he relapsed, the sheriff was bound *ex officio*, if required by the bishop, to commit the unhappy victim to the flames, without waiting for the consent of the crown. This writ remained in force, and was actually executed on two Anabaptists in the seventh of Elizabeth, and on two Arians in the ninth of James I.—Sir Edward Coke was of opinion, that this writ did not lie in his time: but it is now formally taken away by statute 29 Car. II. cap. 9. But this statute does not extend to take away or abridge the jurisdiction of Protestant archbishops or bishops, or any other judges of any ecclesiastical courts, in cases of atheism, blasphemy, heresy, or schism, and other damnable doctrines and opinions; but they may prove and punish the same according to his majesty's ecclesiastical laws, by excommunication, deprivation, degradation, and other ecclesiastical censures, not extending to death, in such sort and no other, as they might have done before the making of this act, sec. 2. See **HERESY**.

HAERLEM. See **HARLEM**.

HAG. See **MYXINE**, **HELMINTHOLOGY Index**.

HAGARENS, the descendants of Ishmael. They are called also *Ishmaelites* and *Saracens*: and lastly, by the general name of *Arabians*.

As to the Hagarens, they dwelt in Arabia the Happy, according to Pliny. Strabo joins them with the Nabathæans, and Chavlotæans, whose habitation was rather in Arabia Deserta. Others think their capital was Petra, otherwise Agra, and consequently they should be placed in Arabia Petraea. The author of the lxxxiii. Psalm, ver. 6. joins them with the Moabites; and in the Chronicles it is said (1 Chr. v. 10.) that the sons of Reuben, in the time of Saul, made war against the Hagarens, and became masters of their country eastward of the mountains of Gilead. This therefore was the true and ancient country of the Hagarens. When Trajan came into Arabia, he besieged the capital of the Hagarens, but could not take it: The sons of Hagar valued themselves of old upon their wisdom, as appears by Baruch iii. 23.

HAGENAU, a town of Germany, and capital of a bailiwick of the same name, which was formerly imperial, but now belongs to the French. It was taken by them in 1673; the Imperialists retook it in 1702; after which it was several times taken and retaken by both parties; but at last the French got possession of it in 1706. It is divided by the river Motter into two parts; and is seated near a forest of its own name, in E. Long. 7. 53. N. Lat. 48. 49.

HAGGAI, the tenth of the small prophets, was born, in all probability, at Babylon, in the year of the world 3457, from whence he returned with Zerubbabel. It was this prophet who by command from God (Ezra v. 1, 2, &c.) exhorted the Jews, after their return

Hæretico

Haggai

Haggai
Hague.

turn from the captivity, to finish the rebuilding of the temple, which they had intermitted for 14 years. His remonstrances had their effect; and to encourage them to proceed in the work, he assured them from God, that the glory of this latter house should be greater than the glory of the former house; which was accordingly fulfilled, when Christ honoured it with his presence: for with respect to the building, this latter temple was nothing in comparison of the former.

We know nothing certain of Haggai's death. The Jews pretend, that he died in the last year of the reign of Darius, at the same time with the prophets Zechariah and Malachi, and that thereupon the spirit of prophecy ceased among the children of Israel. Epiphanius will have it, that he was buried at Jerusalem among the priests. The Greeks keep his festival on the 16th of December, and the Latins on the 4th of July.

HAGIOGRAPHIA, a name given to part of the books of Scripture, called by the Jews *Cetuvim*. The word is compounded of *agios*, "holy;" and *γραφω*, "I write." The name is very ancient: St Jerome makes frequent mention of it: before him, St Epiphanius called these books simply *Γραφια*.

The Jews divide the sacred writings into three classes: The Law, which comprehends the five books of Moses: The Prophets, which they call *Neviim*: And the *Cetuvim* כְּתוּבִים, called by the Greeks, &c. *Hagiographa*; comprehending the books of Psalms, Proverbs, Job, Daniel, Ezra, including also the books of Nehemiah, Chronicles, Canticles, Ruth, the Lamentations, Ecclesiastes, and Esther.

The Jews sometimes call the books the *Writings*, by way of eminence, as being written by immediate inspiration of the Holy Spirit. Thus says Kimchi, in his preface to the Psalms, Maimonides in *More Nevoch*, and Elias Levita in his *Thisbi*, under the word כְּתוּבִים.

They distinguish the hagiographers, however, from the prophets; in that the authors of the former did not receive the matters contained in them by the way called *Prophecy*, which consists in dreams, visions, whispers, ecstasies, &c. but by mere inspiration and direction of the Spirit.

HAGUE, a town of the United Provinces, in Holland, situated in E. Long. 4. 10. N. Lat. 48. 49. —In Latin it is called *Haga Comitum*; in French, *La Haye*; in Dutch, *der Haag*, or *'S-Graavenhage*, i. e. the Earl's Grove or Wood, from the wood near which it is built, and in which the earls of Holland had a country-house. Though it sends no deputies to the states, it is one of the most considerable towns in Holland, pleasantly situated, and exceeding beautiful. It may indeed compare with almost any city in Europe, though geographers account it but a village. The inhabitants also breathe a better air than those of the other cities, as it stands on a dry soil, somewhat higher than the rest of the country. It has no gates or walls, but is surrounded by a moat over which there are many draw-bridges. Two hours are required to walk round it, and it contained about 42,000 inhabitants in 1817. It is a place of much splendor and business, being the seat of the high colleges of the republic and province of Holland, and the residence of the stadtholder and foreign ambassadors; and there

are a great many fine streets and squares in it. In the inner court, all the high colleges and courts of justice hold their assemblies; there also the foot-guards do duty, as the horse-guards in the outer, when the states are sitting. De Plaats is an open airy place, in form of a triangle, adorned with neat and beautiful buildings: the Vyverbeg is an eminence, laid out into several fine shady walks, with the Vyver, a large bason of water, at the bottom: the Voorhout is the most celebrated part of the Hague, and consists of the mall, and three ways for coaches on each side, planted with trees, being much the same as St James's park at London: the palace of Opdam, or Wassenaar, is built in a very elegant taste: the Prince and Princess Grants are fine streets: the Plan, in Dutch *Het Pleyn*, is a beautiful grove, laid out in several cross walks, and surrounded with stately houses. The Jewish synagogue is well worth being seen by a curious traveller; and also the palaces of the prince of Orange, the hotel of Spain, the new Voorhout, the mausoleum of the baron of Opdam in the great church, and the several hospitals. The environs of the Hague are exceedingly pleasant. Among other agreeable objects are the wood, with the palace of Orange at the extremity of it, called the *house in the wood*; the village of Scheveling; and the sand-hills along the north sea; with the village of Voorburg, and the charming seats and fine gardens round it. Two miles from the Hague is Ryswick, a village: and, a quarter of a mile from that, a noble palace formerly belonging to the prince of Orange, famous for the treaty of peace concluded there in 1697. Loosduynen, where Margaret, countess of Henneburg, and daughter of Florence IV. count of Holland and Zealand, is said to have been delivered of 365 children at a birth in 1276, is above five miles from the Hague. Five miles beyond Loosduynen, and not far from the beautiful village of Gravesande, is Honslardyck, another palace belonging to the prince of Orange, and one of the finest structures in the Low Countries.

HAI-NAN. See HAINAN.

Hai-Tang, a beautiful Chinese shrub, originally brought from the bottom of the rocks which border the sea-coast. It has been cultivated in China for more than 14 centuries; and is celebrated as often in the works of the Chinese poets, as roses and lilies are in those of ours. Painters and embroiderers ornament almost all their works with its foliage and flowers. The stalk of the hai-tang is of a cylindric form, and shoots forth a number of branches of a purple tint towards their bases, and full of knots, which are also of a purple colour round the edges. It produces a number of shoots, the tallest of which are about two feet and a half in height. Its leaves (which are much indented, of an oval form towards the stalk, pointed at their upper extremities, and full of small prickles) grow almost opposite one another on the branches, and at the same distance as the knots. Their colour above is a deep-green; that below is much lighter, and almost effaced by their fibres, which are large, and of a delicate purple: all these leaves together have a beautiful effect to the eye. The flowers grow in bunches at the extremities of the branches. Each flower is composed of four petals, two great and two small, resembling in colour the bloom of a peach-tree, and

Hague
Hai-Tang.

which

Hai-Tang, which have almost the same figure as the blossom of our cherry-trees. The two large are cemented one upon the other, in the form of a purse; and when they blow, the two small blow also in their turn; and then the whole four represent a cross. The pistil is composed of very bright yellow grains, which separate gradually one from another by the lengthening of the filaments to which they adhere; they then open into little bells, and compose a small yellow tuft, supported by a slender stalk, which rises above the petals. The calyx, which sustains each of the flowers, is composed of two purple-coloured leaves, united in form of a purse. In proportion as the flowers grow and increase in size, the two leaves of the calyx open, become pale and dry, and drop off. The flowers, supported by small stalks, separate one from the other, and produce of themselves other flowers, which rise up from a new calyx.

This plant is propagated from seed, but with difficulty. It thrives best in a sandy soil; dung or mould destroy it; and great care must be taken to refresh it only with the purest water. As it cannot endure the sun in any season, it is always planted below walls that are exposed to the north. It generally begins to flower about the end of August. After it has produced seed, all its branches are cut; and it commonly shoots forth new ones before the spring following; but it is necessary to heap up gravel and pieces of bricks round its roots, to prevent them from rotting. Notwithstanding all the care that is taken to cultivate this tree at Peking, it does not thrive so well there as in the southern provinces. The smell of its leaves has an affinity both to that of the rose and the violet; but it is weaker, and never extends to any great distance.

HAIL, in *Natural History*, a meteor generally defined frozen rain, but differing from it in that the hailstones are not formed of single pieces of ice, but of many little spherules agglutinated together. Neither are these spherules all of the same consistence; some of them being hard and solid like perfect ice; others soft, and mostly like snow hardened by a severe frost. Sometimes the hailstone hath a kind of core of this soft matter; but more frequently the core is solid and hard, while the outside is formed of a softer matter. Hailstones assume various figures, being sometimes round, at other times pyramidal, crenated, angular, thin, and flat, and sometimes stellated, with six radii like the small crystals of snow.

Natural historians furnish us with various accounts of surprising showers of hail, in which the hailstones were of extraordinary magnitude. Mezeray, speaking of the war of Louis XII. in Italy, in the year 1510, relates, that there was for some time a horrible darkness, thicker than that of night; after which the clouds broke into thunder and lightning, and there fell a shower of hailstones, or rather (as he calls them) pebble-stones, which destroyed all the fish, birds, and beasts of the country.—It was attended with a strong smell of sulphur; and the stones were of a bluish colour, some of them weighing a hundred pounds. *Hist. de France*, tom. ii. p. 339.

At Lisle in Flanders, in 1686, fell hailstones of a very large size; some of which contained in the middle

a dark brown matter, which, thrown on the fire, gave a very great report. *Phil. Trans.* N° 203.

Dr Halley and others also relate, that in Cheshire, Lancashire, &c. April 29. 1697, a thick black cloud, coming from Caernarvonshire, disposed the vapours to congeal in such a manner, that for about the breadth of two miles, which was the limit of the cloud, in its progress for the space of 60 miles, it did inconceivable damage; not only killing all sorts of fowls and other small animals, but splitting trees, knocking down horses and men, and even ploughing up the earth; so that the hailstones buried themselves under ground an inch or an inch and a half deep. The hailstones, many of which weighed five ounces, and some half a pound, and being five or six inches about, were of various figures; some round, others half round; some smooth, others embossed and crenated: the icy substance of them was very transparent and hard, but there was a snowy kernel in the middle of them.

In Hertfordshire, May 4. the same year, after a severe storm of thunder and lightning, a shower of hail succeeded, which far exceeded the former: some persons were killed by it, their bodies beat all black and blue; vast oaks were split, and fields of rye cut down as with a scythe. The stones measured from 10 to 13 or 14 inches about. Their figures were various, some oval, others picked, some flat. *Philosoph. Trans.* N° 229. See *METEOROLOGY Index*.

HAILING, the salutation or accosting of a ship at a distance, either at sea, or in a harbour. The usual expression is "Hoo, the ship aboy!" To which she answers, "Holloa? Whence came ye? Where are ye bound? Good voyage! What cheer? All well! How fare ye?" &c.

HAIMSUCKEN. See **HAMESECKEN**.

HAINAN, a considerable island of Asia, situated in between 18° and 20° N. Lat. It is subject to China, and belongs to the province of Quang-ton. It has on the north the province of Quang-si; on the south the channel formed between the bank Paracel and the eastern coast of Cochinchina; on the west, the same kingdom and part of Tong-king; and on the east, the Chinese sea. Its extent from east to west is between 60 and 70 leagues, and from north to south 45; this island therefore is about 160 leagues in circumference. Kiun-tcheou-sou, its capital, stands on a promontory, and ships often anchor at the bottom of its walls. Two different kinds of mandarins command here, as in all the other provinces of China: the first are called *literati*; the second, *mandarins of arms*, or military officers. Its jurisdiction extends over three cities of the second class and ten of the third. The greater part of the island is under the dominion of the emperor of China; the rest is independent, and inhabited by a free people, who have never yet been subdued. Compelled to abandon their plains and fields to the Chinese, they have retreated to the mountains in the centre of the island, where they are sheltered from the insults of their neighbours.

These people formerly had a free and open correspondence with the Chinese. Twice a-year they exposed, in an appointed place, the gold which they dug from their mines, with their eagle-wood, and calamba, so much esteemed by the Orientals. A deputy was sent

Hail
Hainan.

Hainan,
Hainault.

sent to the frontiers, to examine the cloths and other commodities of the Chinese, whose principal traders repaired to the place of exchange fixed on; and after the Chinese wares were delivered, they put into their hands with the greatest fidelity what they had agreed for. The Chinese governors made immense profits by this barter.

The emperor Kang-hi, informed of the prodigious quantity of gold which passed through the hands of the mandarins by this traffic, forbade his subjects, under pain of death, to have any communication with these islanders: however, some private emissaries of the neighbouring governors still find the means of having intercourse with them; but what they get at present by this clandestine trade is little, in comparison of that which they gained formerly. The natives of this island are very deformed, small of stature, and of a copper colour: both men and women wear their hair thrust through a ring on their forehead; and above they have a small straw-hat, from which hang two strings that are tied under the chin. Their dress consists of a piece of black or dark-blue cotton cloth, which reaches from the girdle to their knees: the women have a kind of robe of the same stuff, and mark their faces from the eyes to the chin with blue stripes made with indigo.

Among the animals of this island are a curious species of large black apes, which have the shape and features of a man; they are said to be very fond of women: there are also found here crows with a white ring round their necks; starlings which have a small crescent on their bills; blackbirds of a deep blue colour, with yellow ears rising half an inch; and a multitude of other birds, remarkable for their colour or song. Besides mines of gold and lapis lazuli, which enrich the island of Hainan, it produces in abundance various kinds of curious and valuable wood. The predecessor of the present emperor caused some of it to be transported to Peking, at an immense expence, to adorn an edifice which he intended for a mausoleum. The most valuable is called by the natives *hoali*, and by the Europeans *rose* or *violet wood* from its smell; it is very durable, and of a beauty which nothing can equal; it is therefore reserved for the use of the emperor.

Hainan, on account of its situation, riches, and extent, deserves to be ranked amongst the most considerable islands of Asia. Not far from thence is another small island, commonly called *San-cian*. It is celebrated by the death of St Francis Xavier: his tomb is still to be seen on a small hill, at the bottom of which is a plain covered on one side with wood, and on the other ornamented with several gardens. This island is not a desert, as some travellers have pretended: it contains five villages; the inhabitants of which are poor people, who have nothing to subsist on but rice and the fish which they catch.

HAINAULT, formerly a province of the Netherlands, belonging partly to France and partly to the house of Austria. It is bounded to the south by France; to the north by Flanders and Brabant; to the east by the duchy of Brabant, the county of Namur, and the bishopric of Liege; and to the west by Artois and Flanders. Its extent from north to south is about 45 miles, and about 48 from east to west. The air is

pleasant and temperate, and the soil fruitful: it abounds in rich pastures, corn-fields, woods and forests, coal, iron, lead, beautiful marble, slate, and other useful stones: it is well watered by rivers and lakes, and breeds abundance of black cattle, and sheep whose wool is very fine. Its principal rivers are the Schelde, the Selle, and the Dender. This province is reckoned to contain 24 walled towns, 950 villages, one duchy, and several principalities, earldoms, peerdoms, and baronies. The abbeys in it are 27. For spiritual matters, the greater part of it is subject to the archbishop of Cambray, and the rest to the bishops of Liege and Arras. The states of the province consist of the clergy, nobility, and commoners. The clergy are the abbots, deputies of the chapters, and rural deans; but the chapters of St Waudru and St Germain, in Mons, send no deputies, as they contribute nothing to the public taxes. The nobility consist of the earls and barons, and all those who by their birth have a right to a seat in the assembly of the states. The commoners are composed of the deputies of the towns. The clergy in this county are uncommonly rich. The states meet only when they are summoned by the sovereign; but there is a standing committee at Mons which meets weekly. This county had counts of its own, till the year 1436; when Philip the Good, duke of Burgundy, arrived to the possession of it, upon the death of Jaqueline, the heiress, without issue. The French acquired that part of it which they possess, partly by the peace of the Pyrenees, and partly by those of Nimeguen and Ryswick. It was formerly governed by a sovereign council, at the head of which was the high bailiff, who had very great authority; he represented the sovereign, was governor of Mons, and captain-general of the province. By the treaty of Luneville, the whole of the province was ceded to France.

HAIR, small filaments issuing out of the pores of the skins of animals; and serving most of them as a tegument or covering*. In lieu of hair, the nakedness of some animals is covered with feathers, wool, scales, &c.

Hair is found on all parts of the human body, except the soles of the feet and the palms of the hands.—But it grows longest on the head, chin, breast, in the armpits, and about the privities.

The ancients held the hair a sort of excrement, fed only with excrementitious matters, and no proper part of a living body.—They supposed it generated of the fuliginous parts of the blood, exhaled by the heat of the body to the surface, and there condensed in passing through the pores.—Their chief reasons were, that the hair being cut, will grow again apace, even in extreme old age, and when life is very low: that in hectic and consumptive people, where the rest of the body is continually emaciating and attenuating, the hair shall thrive: nay, and that it will grow again in dead carcasses.—They added, that hair does not feed and grow like the other parts, by intrususception, i. e. by a juice circulating within it; but, like the nails, by juxtaposition, each part next the root thrusting forward that immediately before it.

But the moderns are agreed, that every hair does properly and truly live, and receive nutriment to fill and distend it like the other parts; which they argue

Hainault,
Hair.

Hair.

hence, that the roots do not turn gray in aged persons sooner than the extremities, but the whole changes colour at once, and the like is observed in boys, &c.; which shows that there is a direct communication, and that all the parts are affected alike.

It may be observed, however, that, in propriety, the life and growth of hairs is of a different kind from that of the rest of the body; and is not immediately derived therefrom, or reciprocated therewith. It is rather of the nature of vegetation. They grow as plants do out of the earth; or, as some plants shoot from the parts of others; from which though they draw their nourishment, yet each has, as it were, its several life and a distinct economy. They derive their food from some juices in the body, but not from the nutritious juices; whence they may live though the body be starved.—Wulferus, in the *Philosophical Collections*, gives an account of a woman buried at Nuremberg, whose grave being opened forty-three years after her death, there was hair found issuing forth plentifully through the clefts of the coffin; insomuch, that there was reason to imagine the coffin had some time been covered all over with hair. The cover being removed, the whole corpse appeared in its perfect shape; but, from the crown of the head to the sole of the foot, covered over with a thick-set hair, long and curled. The sexton going to handle the upper part of the head with his fingers, the whole structure fell at once, leaving nothing in his hand but an handful of hair: there was neither skull nor any other bone left; yet the hair was solid and strong enough.—Mr Arnold, in the same collection, gives a relation of a man hanged for theft, who in a little time, while he yet hung upon the gallows, had his body strangely covered over with hair.—Some moderns, however, deny the authenticity of these and other similar instances.

The hairs ordinarily appear round or cylindrical; but the microscope also discovers triangular and square ones; which diversity of figure arises from that of the pores, to which the hairs always accommodate themselves. Their length depends on the quantity of the proper humour to feed them, and their colour on the quality of that humour: whence, at different stages of life, the colour usually differs. Their extremities split into two or three branches, especially when kept dry, or suffered to grow too long; so that what appears only a single hair to the naked eye, seems a brush to the microscope.

The hair of a mouse, viewed by Mr Derham with a microscope, seemed to be one single transparent tube, with a pith made up of fibrous substances, running in dark lines, in some hairs transversely, in others spirally. The darker medullary parts or lines, he observes, were no other than small fibres convolved round, and lying closer together than in the other parts of the hair. They run from the bottom to the top of the hair, and he imagines, may serve to make a gentle evacuation of some humour out of the body. Hence the hair of hairy animals, this author suggests, may not only serve as a fence against cold, &c. but as an organ of insensible perspiration.

Though the external surface of the body is the natural place of hairs, we have many well-attested instances of their being found also on the internal surface. Amatus Lusitanus mentions a person who had

hair upon his tongue. Pliny and Valerius Maximus concur in their testimonies, that the heart of Aristomenes the Messenian was hairy. Cælius Rhodiginus relates the same of Hermogenes the rhetorician; and Plutarch, of Leonidas the Spartan.—Hairs are said to have been frequently found in the breasts of women, and to have occasioned the distemper called *trichiasis*; but some authors are of opinion, that these are small worms and not hairs. There have been, however, various and indisputable observations of hairs found in the kidneys, and voided by urine.

Hippocrates is of opinion, that the glandular parts are the most subject to hair: but bundles of hair have been found in the muscular parts of beef, and in such parts of the human body as are equally firm with that.—Hair has been often found in abscesses and imposthumations. Schultetus, opening the abdomen of a woman, found 12 pints of water, and a large lock or bundle of hair swimming loose in it. But of all the internal parts, there is none so much subject to an unnatural growth of hair as the ovaries of females, and that as well of the human species as of other animals. Of this Dr Tyson relates three remarkable instances; two of these were young women, and the other was a bitch. The animal had been much emaciated in its hinder parts; the hair was about an inch and a half long: but the most remarkable particular was, that hair was also found lying loose in the cavities of the veins. We have several instances of mankind being affected in the same manner. Cardan relates, that he found hair in the blood of a Spaniard; and Slonatus in that of a gentlewoman of Cracovia; and Schultetus declares from his own observation, that those people who are afflicted with the *plica polonica*, have very often hair in their blood.

Diseases of the Hair. Almost the only disease of the hair, besides the remarkable one called *plica polonica*, is its falling off, or *baldness*. For this many remedies have been recommended, but scarce any of them can be depended upon. The juice of burdock, and the lixivial salts of vine ashes, are said to be efficacious; also the powder of hermodactyls, and the decoction of boxwood. A remarkable instance of the efficacy of this last is given under the article *Buxus*.—Some authors give instances of the hair changing its colour in a short time, through grief, or by reason of a fright, &c.

HAIR as an Ornament, or as an Ensign of Dignity or of Religion. By the Jews hair was worn naturally long, just as it grew; but the priests had theirs cut every fortnight, while they were in waiting at the temple: they made use of no razors, however, but scissars only. The Nazarites, while their vow continued, were forbidden to touch their heads with a razor. See NAZARITE.

The falling off of the hair, or a change of its colour, was regarded amongst the Hebrews as a sign of the leprosy. Black hair was esteemed by them as the most beautiful. Absalom's hair was cut once a-year, and is said to have weighed 200 shekels, by the king's weight, which is about 31 ounces. The law of God hath left no particular ordinances with respect to the hair.

The hair of both Jewish and Grecian women engaged a principal share of their attention, and the Roman

Hair.

Hair.

ladies seem to have been no less curious with respect to theirs. They generally wore it long, and dressed it in a variety of ways, ornamenting it with gold, silver, pearls, &c. On the contrary, the men amongst the Greeks and Romans, and amongst the later Jews, wore their hair short, as may be collected from books, medals, statues, &c. This formed a principal distinction in dress betwixt the sexes. This observation illustrates a passage in St Paul's epistle to the Corinthians (1 Cor. xi. 14. 15.).

St Paul forbids the Corinthian women, when praying by divine inspiration, to have their hair dishevelled; probably because this made them resemble the heathen priestesses, when actuated by the pretended influence of their gods.

Amongst the Greeks, both sexes, a few days before marriage, cut off and consecrated their hair as an offering to their favourite deities. It was also customary among them to hang the hair of the dead on the doors of their houses previous to interment. They likewise tore, cut off, and sometimes shaved their hair, when mourning for their deceased relations or friends, which they laid upon the corpse, or threw into the pile, to be consumed together with the body. The ancients imagined that no person could die till a lock of hair was cut off; and this act they supposed was performed by the invisible hand of death, or Iris, or some other messenger of the gods. The hair, thus cut off, it was supposed, consecrated the person to the infernal deities, under whose jurisdiction the dead were supposed to be. It was a sort of first fruits which sanctified the whole. (See *Virg. Æn.* iv. 694.).

Whatever was the fashion with respect to the hair, in the Grecian states, slaves were forbidden to imitate the freemen. The hair of the slaves was always cut in a particular manner, called *ἡμὴ ἀνδραποδοῦς*, which they no longer retained after they procured their freedom.

It was esteemed a distinguished honour among the ancient Gauls to have long hair, and hence came the appellation *Gallia Comata*. For this reason Julius Cæsar, upon subduing the Gauls, made them cut off their hair as a token of submission. It was with a view to this, that such as afterwards quitted the world to go and live in cloisters, procured their hair to be shaven off; to show that they bade adieu to all earthly ornaments, and made a vow of perpetual subjection to their superiors.

Gregory of Tours assures us, that in the royal family of France, it was a long time the peculiar mark and privilege of kings and princes of the blood to wear long hair, artfully dressed and curled: every body else was obliged to be polled, or cut round, in sign of inferiority and obedience. Some writers assure us, that there were different cuts for all the different qualities and conditions; from the prince who wore it at full length, to the slave or villain who was quite cropt.—To cut off the hair of a son of France, under the first race of kings, was to declare him excluded from the right of succeeding to the crown, and reduced to the condition of a subject.

In the eighth century, it was the custom of people of quality to have their children's hair cut the first time by persons they had a particular honour and esteem

for; who, in virtue of this ceremony, were reputed a sort of spiritual parents or godfathers thereof: Though this practice appears to have been more ancient; inasmuch as we read, that Constantine sent to the pope the hair of his son Heraclius, as a token that he desired him to be his adoptive father.

The parade of long hair became still more and more obnoxious in the progress of Christianity, as something utterly inconsistent with the profession of persons who bore the cross. Hence numerous injunctions and canons to the contrary. Pope Anicetus is commonly supposed to have been the first who forbade the clergy to wear long hair; but the prohibition is of an older standing in the churches of the east; and the letter wherein that decree is written, is of a much later date than that pope.—The clerical tonsure is related by Isidore Hispalensis, as of apostolical institution.

Long hair was anciently held so odious, that there is a canon still extant of the year 1006, importing, that such as wore long hair should be excluded coming into church while living, and not be prayed for when dead. We have a furious declamation of Luitprand against the emperor Phocas, for wearing long hair, after the manner of the other emperors of the east, all except Theophilus, who being bald, enjoined all his subjects to shave their heads.

The French historians and antiquaries have been very exact in recording the head of hair of their several kings. Charlemagne wore it very short, his son shorter; Charles the Bald had none at all. Under Hugh Capet it began to appear again: this the ecclesiastics took in dudgeon, and excommunicated all who let their hair grow. Peter Lombard expostulated the matter so warmly with Charles the Young, that he cut off his hair; and his successors for some generations wore it very short.—A professor of Utrecht, in 1650, wrote expressly on the question, Whether it be lawful for men to wear long hair? and concluded for the negative.—Another divine, named Reves, who had written for the affirmative, replied to him.

The ancient Britons were extremely proud of the length and beauty of their hair, and were at much pains in dressing and adorning their heads. Some of them carried their fondness for and admiration of their hair to an extravagant height. It is said to have been the last and most earnest request of a young warrior, who was taken prisoner and condemned to be beheaded, that no slave might be permitted to touch his hair, which was remarkably long and beautiful, and that it might not be stained with his blood. We hardly ever meet with a description of a fine woman or beautiful man, in the poems of Ossian, but their hair is mentioned as one of their greatest beauties. Not contented with the natural colour of their hair, which was commonly fair or yellow, they made use of certain washes to render it still brighter. One of these washes was a composition of lime, the ashes of certain vegetables, and tallow. They made use of various arts also to make the hair of their heads grow thick and long; which last was not only esteemed a great beauty, but was considered as a mark of dignity and noble birth. Boadicea, queen of the Iceni, is described by Dio with very long hair, flowing over her shoulders, and reaching down below the middle of her back. The Britons shaved!

Hair. shaved all their beards, except their upper lips; the hair of which they, as well as the Gauls, allowed to grow to a very inconvenient length.

In after-times, the Anglo-Saxons and Danes also considered fine hair as one of the greatest beauties and ornaments of their persons, and were at no little pains in dressing it to advantage. Young ladies before marriage wore their hair uncovered and untied, flowing in ringlets over their shoulders; but as soon as they were married, they cut it shorter, tied it up, and put on a head-dress of some kind or other, according to the prevailing fashion. To have the hair entirely cut off was so great a disgrace, that it was one of the greatest punishments inflicted on those women who were guilty of adultery. The Danish soldiers who were quartered upon the English, in the reigns of Edgar the Peaceable and of Ethelred the Unready, were the beaux of those times, and were particularly attentive to the dressing of their hair; which they combed at least once every day, and thereby captivated the affections of the English ladies. The clergy, both secular and regular, were obliged to shave the crowns of their heads, and keep their hair short, which distinguished them from the laity; and several canons were made against their concealing their tonsure, or allowing their hair to grow long. The shape of this clerical tonsure was the subject of long and violent debates between the English clergy on the one hand, and those of the Scots and Picts on the other; that of the former being circular, and that of the latter only semicircular. It appears very plainly, that long flowing hair was universally esteemed a great ornament; and the tonsure of the clergy was considered as an act of mortification and self-denial, to which many of them submitted with reluctance, and endeavoured to conceal as much as possible. Some of them who affected the reputation of superior sanctity inveighed with great bitterness against the long hair of the laity; and laboured earnestly to persuade them to cut it short, in imitation of the clergy. Thus the famous St Wulstan bishop of Worcester, is said to have declaimed with great vehemence against luxury of all kinds, but chiefly against long hair as most criminal and most universal. "The English (says William of Malmesbury in his life of St Wulstan) were very vicious in their manners, and plunged in luxury, through the long peace which they had enjoyed in the reign of Edward the Confessor. The holy prelate Wulstan reproved the wicked of all ranks with great boldness; but he rebuked those with the greatest severity who were proud of their long hair. When any of those vain people bowed their heads before him to receive his blessing, before he gave it, he cut a lock of their hair with a little sharp knife, which he carried about him for that purpose; and commanded them, by way of penance for their sins, to cut all the rest of their hair in the same manner. If any of them refused to comply with this command, he denounced the most dreadful judgments upon them, reproached them for their effeminacy, and foretold, that as they imitated women in the length of their hair, they would imitate them in their cowardice when their country was invaded; which was accomplished at the landing of the Normans."

This continued to be long a topic of declamation among the clergy, who even represented it as one of

the greatest crimes, and most certain marks of reprobation. Anselm, archbishop of Canterbury, went so far as to pronounce the terrible sentence of excommunication against all who wore long hair, for which pious zeal he is very much commended. Serlo, a Norman bishop, acquired great honour by a sermon which he preached before Henry I. A. D. 1104, against long and curled hair, with which the king and all his courtiers were so much affected, that they consented to resign their flowing ringlets, of which they had been so vain. The prudent prelate gave them no time to change their minds, but immediately pulled a pair of shears out of his sleeve, and performed the operation with his own hand. Another incident happened about 25 years after, which gave a temporary check to the prevailing fondness for long hair. It is thus related by a contemporary historian: "An event happened, A. D. 1129, which seemed very wonderful to our young gallants; who, forgetting that they were men, had transformed themselves into women by the length of their hair. A certain knight, who was very proud of his long luxuriant hair, dreamed that a person suffocated him with its curls. As soon as he awoke from his sleep, he cut his hair to a decent length. The report of this spread ever all England, and almost all the knights reduced their hair to the proper standard. But this reformation was not of long continuance; for in less than a year all who wished to appear fashionable returned to their former wickedness, and contended with the ladies in length of hair. Those to whom nature had denied that ornament supplied the defect by art."

The Greeks, and, after their example, the Romans, wore false hair.

Commerce in HAIR. Hair makes a very considerable article in commerce, especially since the mode of perukes has obtained. The hair of the growth of the northern countries, as England, &c. is valued much beyond that of the more southern ones, as Italy, Spain, the south parts of France, &c. The merit of good hair consists in its being well fed, and neither too coarse nor too slender; the bigness rendering it less susceptible of the artificial curl, and disposing it rather to frizzle, and the smallness making its curl of too short duration. Its length should be about 25 inches; the more it falls short of this, the less value it bears.

There is no certain price for hair; but it is sold from five shillings to five pounds an ounce, according to its quality.

The scarceness of gray and white hair has put the dealers in that commodity upon the methods of reducing other colours to this. This is done by spreading the hair to bleach on the grass like linen, after first washing it out in a lixivious water. This ley, with the force of the sun and air brings the hair to so perfect a whiteness, that the most experienced person may be deceived therein; there being scarce any way of detecting the artifice, but by boiling and drying it, which leaves the hair of the colour of a dead walnut-tree leaf.

There is also a method of dyeing hair with bismuth, which renders such white hair as borders too much upon the yellow of a bright silver colour: boiling is the proof of this too, the bismuth not being able to stand it.

Hair.

Hair

Hair.

Hair may be also changed from a red, gray, or other disagreeable colour, to a brown or deep black, by a solution of silver. The liquors sold under the name of *hair-waters*, are at bottom no more than solutions of silver in aquafortis, largely diluted with water, with the addition perhaps of other ingredients, which contribute nothing to their efficacy. The solution should be fully saturated with the silver, that there may be no more acid in it than is necessary for holding the metal dissolved; and besides dilution with water, a little spirit of wine may be added for the further dulcification of the acid. It must be observed, that for diluting the solution, distilled water, or pure rain-water, must be used; the common spring-waters turning it milky, and precipitating a part of the dissolved silver.—It is to be observed also, that if the liquor touches the skin, it has the same effect on it as on the matter to be stained, changing the part moistened with it to an indelible black.—Hair may also be dyed of any colour, in the same manner as wool.

Hair which does not curl or buckle naturally is brought to it by art, by first boiling and then baking it in the following manner: After having picked and sorted the hair, and disposed it in parcels according to lengths, they roll them up and tie them tight down upon little cylindrical instruments, either of wood or earthen ware, a quarter of an inch thick, and hollowed a little in the middle, called *pipes*; in which state they are put in a pot over the fire, there to boil for about two hours. When taken out, they let them dry; and when dried, they spread them on a sheet of brown paper, cover them with another, and thus send them to the pastry-cook; who making a crust or coffin around them of common paste, sets them in an oven till the crust is about three-fourths baked.

The end by which a hair grows to the head is called the *head of the hair*; and the other, with which they begin to give the buckle, the *point*. Formerly the peruke-makers made no difference between the ends, but curled and wove them by either indifferently: but this made them unable to give a fine buckle; hair woven by the point never taking a right curl. Foreigners own themselves obliged to the English for this discovery, which was first carried abroad by a peruke-maker of our country.

Hair is also used in various other arts and manufactures.—In particular, the hair of beavers, hares, conies, &c. is the principal matter whereof hats are made. Spread on the ground, and left to putrefy on corn-lands, hair, as all other animal substances, viz. horns, hoofs, blood, garbage, &c. proves good manure.

HAIR, in *Farriery*, is generally called the *coat*; and, with regard to horses, deserves particular consideration. The hair growing on the fetlock serves as a defence to the prominent part of it in travelling in stony ways or in frosty weather. If the hair of a horse's neck, and the parts most uncovered, be close, smooth, and sleek, it is an indication of his being in health and good case. In order to make the hair of a horse soft and sleek, he must be kept warm at heart, for the least inward cold will cause the hair to stare; also sweat him often, for that will loosen and raise the dust and filth that renders his coat foul; and when he is in the heat of a sweat, scrape off all the white foam, sweat, and filth, that is raised up with an old sword blade; and also when he is

blooded, if you rub him all over with his own blood, repeating it two or three days, and curry and dress him well, it will make his coat shine as if covered with a fine varnish.

Hair falling from the mane or tail is caused either by his having taken some heat, which has engendered a dry mange; or from some affection of the skin. To cure this, anoint the horse's mane and crest with black soap; make a strong ley of ashes, and wash it all over with it. But if a canker should grow on a horse's tail, which will eat away both flesh and bone, oil of vitriol is recommended to be applied to the part affected. But as this is a very dangerous application, lunar caustic will be found a safer and an equally effectual remedy.

If you would take away hair from any part of a horse's body, boil half a pound of lime in a quart of water, till a fourth part is consumed, to which add an ounce of orpiment; make this into a plaster, and lay it on.

HAIR, or *Down*, of plants; a general term expressive of all the hairy and glandular appearances on the surface of plants, to which they are supposed by naturalists to serve the double purpose of defensive weapons and vessels of secretion.

These hairs are minute threads of greater or less length and solidity; some of them visible to the naked eye, whilst others are rendered visible only by the help of glasses. Examined by a microscope, almost all the parts of plants, particularly the young stalks or stems, appear covered with hairs.

Hairs on the surface of plants present themselves under various forms; in the leguminous plants, they are generally cylindric; in the mallow tribe, terminated in a point; in agrimony, shaped like a fish-hook; in nettle, awl-shaped and jointed; and in some compound flowers with hollow or funnel-shaped florets, they are terminated in two crooked points.

Probable as some experiments have rendered it, that the hairs on the surface of plants contribute to some organical secretion, their principal use seems to be to preserve the parts in which they are lodged from the bad effects of violent frictions, from winds, from extremes of heat and cold, and such like external injuries.

M. Guettard, who established a botanical method from the form, situation, and other circumstances of the hairy and glandular appearances on the surface of plants, demonstrated, that these appearances are generally constant and uniform in all the plants of the same genus. The same uniformity seems to characterise all the different genera of the same natural order.

The different sorts of hairs which form the down upon the surface of plants were imperfectly distinguished by Grew in 1682, and by Malpighi in 1686. M. Guettard just mentioned was the first who examined the subject both as a botanist and a philosopher. His observations were published in 1747.

HAIR-Cloths, in military affairs, are large pieces of cloth made with half hair. They are used for covering the powder in waggons, or upon batteries; as also for covering charged bombs or hand-grenades, and many other uses in magazines.

HAIR-Powder. See STARCH.

HAIR-Worm. See GORDIUS, HELMINTHOLOGY Index.

Hair
|
Hair-
Worm.

Hake
Halberstadt.

HAKE, the English name of a fish common in the English and some other seas, called by authors the *merlucius* and *lucius marinus*. This fish was used of old dried and salted. Hence the proverb obtains in Kent, *As dry as a hake*. See *ICHTHYOLOGY Index*.

HAKLUYT, RICHARD, a naval historian, is supposed to have been born in London about the year 1553, and descended of a genteel family in Herefordshire, as the name frequently occurs in the list of high sheriffs for that county in former reigns. He was educated at Westminster-school; and thence, in 1570, removed to Christ-church, Oxford; where he applied himself particularly to the study of cosmography, and read public lectures in that science. Sir Edward Stafford being sent ambassador to France in 1583, Mr Hakluyt was one of his attendants, probably in the capacity of chaplain. He was at this time master of arts and professor of divinity. In 1585, he obtained the royal mandate for the next vacant prebend of Bristol, to which preferment he succeeded during his residence at Paris. Constantly attentive to his favourite cosmographical inquiries, in searching the French libraries, he found a valuable history of Florida, which had been discovered about 20 years before by Captain Loudonniere and others: this he caused to be published, at his own expence, in the French language, and soon after revised and republished Peter Martyr's book *De orbe novo*. After five years residence in France, Mr Hakluyt returned to England in company with Lady Sheffield, sister to the lord admiral Howard. In the year 1589, he published his *Collection of Voyages* in one folio volume, which in 1598 was republished in three. In 1605, our author was made prebendary of Westminster; which, with the rectory of Wetheringset in the county of Suffolk, seems to have been the summit of his preferment. He died in 1616, and was buried in Westminster-abbey; bequeathing to his son Edmund his manor of Bridge Place, and several houses in Tothil-street, Westminster. He was an indefatigable and faithful historian. His works are, 1. *A Collection of Voyages and Discoveries*, a small volume. 2. *History of Florida*, above mentioned. 3. *The principal Navigations, Voyages, and Discoveries of the English Nation, made by Sea or over Land to the furthest distant Quarters of the Earth, at any time within the compass of these 1500 years*, in three vols folio. 4. *The Discoveries of the World, from the first Original to the Year 1555*, written in the Portugal tongue by Ant. Galvano; corrected, much amended and translated into English, by Richard Hakluyt. 5. *Virginia richly valued, by the Description of the Main Land of Florida, her next Neighbour, &c.* written by a Portugal gentleman of Elvas, and translated by Richard Hakluyt. Besides these, he left several manuscripts, which were printed in Purchas's collection.

HALBERSTADT, a small district of Germany, bounded on the north-east by the duchy of Magdeburg, on the south by the principality of Anhalt, on the west by the diocese of Hildsheim, on the east by part of the electorate of Saxony, and on the north by Brunswick Wolfenbuttle. It is now subject to Prussia, and forms part of the government of Magdeburg. It is near 40 miles in length and 30 in breadth. The soil in general is fertile in corn and flax; and there are some woods, though in general fuel is scarce. There are three

large towns in it which send representatives to the diet, together with 10 small ones, and 91 county-towns and villages. The number of the inhabitants is computed at about 200,000: the greatest part of them are Lutherans; but there are also Calvinists, Jews, and Roman Catholics. The manufactures are chiefly woollen (for the country produces a great number of sheep); the exports are grain; and a kind of beer called *broi-han*. The annual revenue arising from this principality, and the incorporated counties and lordships, is said to amount to 500,000 rix-dollars. Till the treaty of Westphalia in 1648 this country was a diocese, but was then transferred to the electoral house of Brandenburg as a temporal principality. The principal places are Halberstadt, Groningen, Oschersleben, Osterwick, &c.

HALBERSTADT, a city of Germany, in the circle of Lower Saxony, seated near the river Hothein. It is a neat uniform place; and has some good churches and other handsome buildings, of which the cathedral is the chief. There is an inn in this place, which is looked upon to be the largest and to have the best accommodations of any in Europe. Before the Reformation it was a bishop's see. Inhabitants above 12,000. E. Long. 11. 12. N. Lat. 51. 54.

HALBERT, or **HALBARD**, in the art of war, a well-known weapon carried by the serjeants of foot and dragoons. It is a sort of spear, the shaft of which is about five feet long, and made of ash or other wood. Its head is armed with a steel point, not unlike the point of a two-edged sword. But, besides this sharp point which is in a line with the shaft, there is a cross piece of steel, flat and pointed at both ends; but generally with a cutting edge at one extremity, and a bent sharp point at the other; so that it serves equally to cut down or to push withal. It is also useful in determining the ground between the ranks, and adjusting the files of a battalion. The word is formed of the German *hal*, "hall," and *bard* "an hatchet." Vossius derives it from the German *hallebaert*, of *hel*, "clarus, splendens," and *baert*, "axe."

The halbert was anciently a common weapon in the army, where there were companies of halberdiers. It is said to have been used by the Amazons, and afterwards by the Rhatians and Vindelicians about the year 570.

It was called the *Danish axe*, because the Danes bore an halbert on the left shoulder. From the Danes it was derived to the Scots, from the Scots to the English Saxons, and from them to the French.

HALCYON, the ancient name of the alcedo or king's fisher. See *ALCEDO, ORNITHOLOGY Index*.

HALCYON Days, in antiquity, a name given to seven days before and as many after the winter solstice; by reason the halcyon, invited by the calmness of the weather, laid its eggs in nests built in the rocks, close by the brink of the sea, at this season; and hence *halcyon days* is a phrase expressive of times of peace and tranquillity.

HALDE, JOHN BAPTIST DU, was born at Paris in the year 1674, and having entered into the society of the Jesuits, he was by them entrusted with the care of collecting and arranging the letters which they received from different quarters of the globe. He also filled the

Halberstadt
Halde.

Hale,
Hale.

the office of secretary to Father le Tellier, who was confessor to the king of France. He died in the year 1743, leaving a character behind him truly amiable for mildness, piety, and unwearied industry. He was the author of some Latin poems, but that which most distinguished him was his being the editor of the *Lettres Edifiantes et Curieuses*, from the ninth to the 26th collection inclusive, with a valuable preface written by himself. He was also the author, (some say editor) of *Description Historique, Geographique, et Physique, de l'Empire de la Chine, et de la Tartarie Chinoise*, 4 vols folio, considered as the completest account of that prodigious empire which has appeared in Europe. It has, with some necessary abridgements, been translated into English. It has all the appearance of veracity, and the style is simple and unaffected.

HALE, in the sea language, signifies *pull*; as, to hale up, is to pull up; to hale in or out, is to pull in or out. To over-hale a rope, is to hale it too stiff, or to hale it the contrary way.

Keel-HALE. See DUCKING.

HALE, Sir *Matthew*, lord chief justice of the king's bench in the reign of Charles II. was the son of Robert Hale, Esq. a barrister of Lincoln's Inn, and was born in 1609. He was educated at Oxford, where he made a considerable progress in learning; but was afterwards diverted from his studies by the levities of youth. From these he was reformed by Mr John Glanvill serjeant at law; and applying to the study of the law, entered into Lincoln's Inn. Noy the attorney-general took early notice of him, and directed him in his studies. Mr Selden also took much notice of him; and it was this acquaintance that first set Mr Hale on a more enlarged pursuit of learning, which he had before confined to his own profession. During the civil wars, he behaved so well as to gain the esteem of both parties. He was employed in his practice by all the king's party; and was appointed by the parliament one of the commissioners to treat with the king. The murder of King Charles gave him very sensible regret. However, he took the engagement; and was appointed, with several others, to consider of the reformation of the law. In 1653 he was by writ made serjeant at law, and soon after appointed one of the justices of the Common Pleas. Upon the death of Oliver Cromwell he refused to accept of the new commission offered him by Richard his successor. He was returned one of the knights of Gloucestershire in the parliament which called home Charles II. Soon after he was made lord chief baron of the exchequer; but declined the honour of knighthood, till lord chancellor Hyde, sending for him upon business when the king was at his house, told his majesty, that "there was his modest chief baron;" upon which he was unexpectedly knighted. He was one of the principal judges that sat in Clifford's Inn about settling the difference between landlord and tenant, after the fire of London, in which he behaved to the satisfaction of all parties concerned, and also in his post of chief baron acted with inflexible integrity. One of the first peers went once to his chamber, and told him, "That having a suit in law to be tried before him, he was then to acquaint him with it, that he might the better understand it when it should come to be tried in court." Upon which the lord chief baron interrupted him, and

said, "He did not deal fairly to come to his chambers about such affairs; for he never received information of such causes but in open court, where both parties were to be heard alike." Upon which his grace (for he was a duke) went away not a little dissatisfied, and complained of it to the king as a rudeness that was not to be endured; but his majesty bid him content himself that he was used no worse; and said, "That he verily believed he would have used him no better if he had gone to solicit him in any of his own causes." Another remarkable incident happened in one of his circuits. A gentleman who had a trial at the assizes had sent him a buck for his table. When Judge Hale therefore heard his name, he asked "if he was not the same person who had sent him the venison?" and finding that he was the same, told him, that "he could not suffer the trial to go on till he had paid him for his buck." The gentleman answered, that "he never sold his venison; and that he had done nothing to him which he did not do to every judge who had gone that circuit:" which was confirmed by several gentlemen present. The lord chief baron, however, would not suffer the trial to proceed till he had paid for the present: upon which the gentleman withdrew the record. In short, he was in 1671 advanced to be lord chief justice of the king's bench; but about four years after this promotion, his health declining, he resigned his post in February 1675-6, and died in December following. This excellent man, who was an ornament to the bench, to his country, and to human nature, wrote, 1. An Essay on the Gravitation and Non-gravitation of Fluid Bodies. 2. Observations touching the Torricellian Experiment. 3. Contemplations, moral and divine. 4. The Life of Pomponius Atticus, with political and moral Reflections. 5. Observations on the Principles of natural Motion. 6. The primitive Origination of Mankind. He also left a great number of manuscripts, in Latin and English, upon various subjects; among which are, his Pleas of the Crown, since published by Mr Emyln in two volumes folio; and his Original Institution, Power, and Jurisdiction of Parliaments.

HALES, STEPHEN, D. D. a celebrated divine and philosopher, was born in 1677. He was the sixth son of Thomas Hales, Esq. the eldest son of Sir Robert Hales, created a baronet by King Charles II. and Mary the heiress of Richard Langley of Abbots-Wood in Hertfordshire. In 1696 he was entered a pensioner at Bennet-college, Cambridge; and was admitted a fellow in 1703, and became bachelor of divinity in 1711. He soon discovered a genius for natural philosophy. Botany was his first study; and he used frequently to make excursions among Gogmagog hills, in company with Dr Stukely, with a view of prosecuting that study. In these expeditions he likewise collected fossils and insects, having contrived a curious instrument for catching such of the latter as have wings. In company with this friend he also applied himself to the study of anatomy, and invented a curious method of obtaining a representation of the lungs in lead. They next applied themselves to the study of chemistry; in which, however, they did not make any remarkable discoveries. In the study of astronomy Mr Hales was equally assiduous. Having made himself acquainted with the Newtonian system, he contrived a machine.

Hale,
Hales.

Hales. for showing the phenomena on much the same principles with that afterwards made by Mr Rowley, and, from the name of his patron, called an *Orrery*.

About the year 1710 he was presented to the perpetual cure of Taddington near Twickenham, in Middlesex; and afterwards accepted of the living of Porlock in Somersetshire, which vacated his fellowship in the college, and which he exchanged for the living of Faringdon in Hampshire. Soon after, he married Mary, the daughter and heiress of Dr Newce, who was rector of Halesham in Sussex, but resided at Much-Haddam in Hertfordshire. On the 13th of March 1718, he was elected a member of the Royal Society; and on the 5th of March, in the year following, he exhibited an account of some experiments he had lately made on the effect of the sun's warmth in raising the sap in trees. This procured him the thanks of the society, who also requested him to prosecute the subject. With this request he complied with great pleasure; and on the 14th of June 1725 exhibited a treatise in which he gave an account of his progress. This treatise being highly applauded by the Society, he farther enlarged and improved it; and in April 1727 he published it under the title of *Vegetable Statics*. This work he dedicated to his majesty King George II. who was then prince of Wales: and he was the same year chosen one of the council of the Royal Society, Sir Hans Sloane being at the same annual election chosen their president. The book being well received, a second edition of it was published in 1731. In a preface to this edition Mr Hales promised a sequel to the work, which he published in 1733 under the title of *Statistical Essays, &c.* In 1732 he was appointed one of the trustees for establishing a new colony in Georgia. On the 5th of July 1733 the university of Oxford honoured him with a diploma for the degree of doctor in divinity; a mark of distinction the more honourable, as it is not usual for one university to confer academical honours on those who are educated at another. In 1734, when the health and morals of the lower and middling class of people were subverted by the excessive drinking of gin, he published, though without his name, A friendly Admonition to the Drinkers of Brandy and other spirituous Liquors; which was twice reprinted. The latter end of the same year he published a sermon which he preached at St Bride's before the rest of the trustees for establishing a new colony in Georgia. His text was, "Bear ye one another's burthens, and so fulfil the law of Christ;" Galatians vi. 2. In 1739 he printed a volume in 8vo, entitled, Philosophical Experiments on Sea-water, Corn, Flesh, and other Substances. This work, which contained many useful instructions for voyagers, was dedicated to the lords of the admiralty. The same year he exhibited to the Royal Society an account of some farther experiments towards the discovery of medicines for dissolving the stone in the kidneys and bladder, and preserving meat in long voyages; for which he received the gold medal of Sir Godfrey Copley's donation. The year following he published some account of Experiments and Observations on Mrs Stephen's Medicines for dissolving the Stone, in which their dissolvent power is enquired into and demonstrated.

In 1741 he read before the Royal Society an account of an instrument which he invented, and called

a ventilator, for conveying fresh air into mines, hospitals, prisons, and the close parts of ships: he had communicated it to his particular friends some months before; and it is very remarkable, that a machine of the same kind, for the same purpose, was in the spring of the same year invented by one Martin Triewald, an officer in the service of the king of Sweden, called *captain of mechanics*, for which the king and senate granted him a privilege in October following, and ordered every ship of war in the service of that state to be furnished with one of them: a model also of this machine was sent into France, and all the ships in the French navy were also ordered to have a ventilator of the same sort. It happened also, that about the same time one Sutton, who kept a coffeehouse in Aldergate-street, invented a ventilator of another construction to draw off the foul air out of ships by means of the cook-room fire: but poor Sutton had not interest enough to make mankind accept the benefit he offered them; though its superiority to Dr Hales's contrivance was evident, and among others Dr Mead and the ingenious Mr Benjamin Robins gave their testimony in its favour (see *Art-Pipes*). The public, however, is not less indebted to the ingenuity and benevolence of Dr Hales, whose ventilators came more easily into use for many purposes of the greatest importance to life, particularly for keeping corn sweet, by blowing through it fresh showers of air; a practice very soon adopted by France, a large granary having been made, under the direction of Dubamel, for the preservation of corn in this manner, with a view to make it a general practice.

In 1743, Dr Hales read before the Royal Society a description of a method of conveying liquors into the abdomen during the operation of tapping, and it was afterwards printed in their Transactions. In 1745, he published some experiments and observations on tar-water, which he had been induced to make by the publication of a work called *Siris*, in which the learned and most excellent Dr Berkeley, bishop of Cloyne, had recommended tar-water as an universal medicine: on this occasion several letters passed between them on the subject, particularly with respect to the use of tar-water in the disease of the horned cattle. In the same year he communicated to the public, by a letter to the editor of the Gentleman's Magazine, a description of a *back-sifter*, which will winnow and clean corn much sooner and better than can be done by the common method. He also, at the same time, and by the same channel, communicated to the public a cheap and easy way to preserve corn sweet in sacks; an invention of great benefit to farmers, especially to poor leasers, who want to keep small quantities of corn for some time, but have no proper granary or repository for that purpose. He also the same year took the same method to publish directions how to keep corn sweet in heaps without turning it, and to sweeten it when musty. He published a long paper, containing an account of several methods to preserve corn by ventilators; with a particular description of several sorts of ventilators, illustrated by a cut, so that the whole mechanism of them may be easily known, and the machine constructed by a common carpenter. He published also in the same volume, but without his name, a detection of the fallacious boasts concerning the efficacy of the liquid shell

Hales. in dissolving the stone in the bladder. In 1746 he communicated to the Royal Society a proposal for bringing small passable stones soon, and with ease, out of the bladder; and this was also printed in their Transactions. In the Gentleman's Magazine for July 1747, he published an account of a very considerable improvement of his back-heaver, by which it became capable of clearing corn of the very small grain, seeds, blacks, smutt-balls, &c. to such perfection as to make it fit for seed-corn. In 1748 he communicated to the Royal Society a proposal for checking, in some degree, the progress of fires, occasioned by the great fire which happened that year in Cornhill: And the substance of this proposal was printed in their Transactions. In the same year he also communicated to the Society two memoirs, which are printed in their Transactions; one on the great benefit of ventilators, and the other on some experiments in electricity. In 1749, his ventilators were fixed in the Savoy prison, by order of the right hon. Henry Fox, Esq. then secretary at war, afterwards Lord Holland; and the benefit was so great, that though 50 or 100 in a year often died of the gaol distemper before, yet from the year 1749 to the year 1752 inclusive, no more than four persons died, though in the year 1750 the number of prisoners was 240; and of those four, one died of the small-pox, and another of intemperance. In the year 1750 he published some considerations on the causes of earthquakes; occasioned by the slight shocks felt that year in London. The substance of this work was also printed in the Philosophical Transactions. The same year he exhibited an examination of the strength of several purging waters, especially of the water of *Jessop's well*, which is printed in the Philosophical Transactions.

Dr Hales had now been several years honoured with the esteem and friendship of his royal highness Frederick prince of Wales; who frequently visited him at Teddington, from his neighbouring palace at Kew, and took a pleasure in surprising him in the midst of those curious researches into the various parts of nature which almost incessantly employed him. Upon the prince's death, which happened this year, and the settlement of the household of the princess dowager, he was, without his solicitation, or even knowledge, appointed clerk of the closet or almoner to her royal highness. In 1751 he was chosen by the college of physicians to preach the annual sermon called *Crowne's lecture*: Dr William Crowne having left a legacy for a sermon to be annually preached on "the wisdom and goodness of God displayed in the formation of man." Dr Hales's text was, *With the ancient is wisdom, and in length of days understanding*, Job xii. 12. This sermon, as usual, was published at the request of the college. In the latter end of the year 1752, his ventilators, worked by a windmill, were fixed in Newgate, with branching trunks to 24 wards; and it appeared that the disproportion of those that died in the gaol before and after this establishment was as 16 to 7. He published also a farther account of their success, and some observations on the great danger arising from foul air, exemplified by a narrative of several persons seized with the gaol-fever by working in Newgate.

On the death of Sir Hans Sloane, which happened in the year 1753, Dr Hales was elected a member of the

Academy of Sciences at Paris in his room. The same year he published in the Gentleman's Magazine some farther considerations about means to draw the foul air out of the sick rooms of occasional army hospitals, and private houses in town. He also published many other curious particulars relative to the use and success of ventilators. The same year a description of a sea-gage, which the Doctor invented to measure unfathomable depths, was communicated to the public in the same miscellany: this paper was drawn up about the year 1732 or 1733, by the Doctor, for Colin Campbell, Esq. This gentleman employed the ingenious Mr Hawksbee to make the machine it describes, which was tried in various depths, and answered with great exactness. It was however lost near Bermuda. In 1754, he communicated to the Royal Society some experiments for keeping water and fish sweet with lime-water, an account of which was published in the Philosophical Transactions. He also continued to enrich their memoirs with many useful articles from this time till his death, particularly a method of forwarding the distillation of fresh from salt water, by blowing showers of fresh air up through the latter during the operation. In 1757 he communicated to the editor of the Gentleman's Magazine an easy method of purifying the air, and regulating its heat in melon-frames and green-houses; also further improvements in his method of distilling sea-water.

His reputation and the interest of his family and friends might easily have procured him farther preferment: but of farther preferment he was not desirous; for being nominated by his late majesty to a canonry of Windsor, he engaged the princess to request his majesty to recal his nomination. That a man so devoted to philosophical studies and employments, and so conscientious in the discharge of his duty, should not desire any preferment which should reduce him to the dilemma either of neglecting his duty, or foregoing his amusement, is not strange; but that he would refuse an honourable and profitable appointment, for which no duty was to be done that would interrupt his habits of life, can scarce be imputed to his temperance and humility without impeaching his benevolence; for if he had no wish of any thing more for himself, a liberal mind would surely have been highly gratified by the distribution of so considerable a sum as a canonry of Windsor would have put into his power, in the reward of industry, the alleviation of distress, and the support of helpless indigence. He was, however, remarkable for social virtue and sweetness of temper; his life was not only blameless, but exemplary in a high degree; he was happy in himself and beneficial to others, as appears by this account of his attainments and pursuits; the constant serenity and cheerfulness of his mind, and the temperance and regularity of his life, concurred, with a good constitution, to preserve him in health and vigour to the uncommon age of fourscore and four years. He died at Teddington in 1761; and was buried, pursuant to his own directions, under the tower of the parish church, which he built at his own expence not long before his death. Her royal highness the princess of Wales erected a monument to his memory in Westminster abbey."

Halesia

HALESIA, a genus of plants belonging to the decandria class, and in the natural method ranking under the 18th order, *Bicornes*. See *BOTANY Index*.

HALESWORTH, a town of Suffolk in England, seated on a neck of land between two branches of the river Blith, 101 miles from London. It has a trade in linen-yarn and sail-cloth, one large church, and in 1811 had 1810 inhabitants. About the town is raised a great deal of hemp. E. Long. 1. 29. N. Lat. 52. 21.

HALF-BLOOD, in *Law*, is where a man marries a second wife, the first being dead, and by the first venter he has a son, and by his second venter has likewise a son; the two brothers, in this case, are but of half-blood. See *CONSANGUINITY* and *DESCENT*.

HALF-Merk; a noble, or 6s. 8d.

HALF-Moon, in *Fortification*; an outwork composed of two faces, forming a salient angle, whose gorge is in form of a crescent or half-moon, whence the name.

HALFPENNY, a copper coin, whose value is expressed by its name, in reference to the penny.

HALI-BEIGH, first dragoman or interpreter at the Grand Signior's court in the 17th century, was born of Christian parents in Poland; but having been taken by the Tartars when he was young, they sold him to the Turks, who brought him up in their religion in the seraglio. His name, in his native country, was Bobowski. He learnt many languages, and Sir Paul Ricaut owns he was indebted to him for several things which he relates in his *Present state of the Ottoman empire*. He held a great correspondence with the English, who persuaded him to translate some books into the Turkish language; and he proposed to return into the bosom of the Christian church, but died before he could accomplish the design. Dr Hyde published his book *Of the liturgy of the Turks, their pilgrimages to Mecca, their circumcision and visiting of the sick*. He translated the catechism of the church of England and the bible into the Turkish language. The MS. is lodged in the library of Leyden. He wrote likewise a Turkish grammar and dictionary.

HALICARNASSUS, in *Ancient Geography*, a principal town of Caria, said to be built by the Argives, and situated between two bays, the Ceramicus and Jasius.

It was the royal residence, (called *Zephyra* formerly); especially of Mausolus, made more illustrious by his monument. This monument was one of the seven wonders, and erected by Artemisia. Halicarnasseus, or Halicarnassensis, was the gentilitious name of Herodotus and Dionysius. The former was called the Father of History; and the latter was not only a good historian but also a distinguished critic.

HALIÆTUS. See *FALCO*, *ORNITHOLOGY Index*.

HALIEUTICS, **HALIEUTICA**, *ἁλιευτικά*, formed of *ἄλιος*, fisherman, which is derived from *ἄλς*, sea; books treating of fishes, or the art of fishing. We have still extant the halieutics of Oppian.

HALIFAX, the capital of the province of Nova Scotia in America, situated in W. Long. 63. 36. N. Lat. 44. 45. It was founded in 1749, in order to secure the British settlements there from the attempts of the French and Indians. It was divided into 35 squares, each containing 16 lots of 40 by 60 feet; one established church and one meeting-house, and a small number of houses out of the regular streets.

The town was originally guarded by forts on the outside; but from the commencement of the American revolution, it was very strongly fortified. Along the river Chebucto, to the southward of the town, are buildings and fish-flakes for at least two miles, and to the northward on the river for about one mile. The plan, however, was greatly improved by the earl of Halifax, who was the original contriver. The proclamation issued for this settlement, offered 50 acres of land to every soldier and sailor who would settle in that part of America, without rent or service, for ten years, and no more than one shilling per annum for each 50 acres ever afterwards: to every soldier and sailor who had a wife and children, ten acres more were added for every individual of his family, and for every increase that should afterwards happen in the same proportion: To each non-commissioned officer 80 acres, and 15 for each of his family; 200 acres to each ensign; 300 to each lieutenant; 400 to each captain; 600 to every officer in rank above a captain, and 30 for each of his family. Government also engaged to transport and maintain the new settlers for one year at its own expence, and furnish them with such arms, provisions, utensils, implements, &c. as should be necessary to put them in a way to cultivate their lands, to build habitations, and to commence a fishery. The same conditions were likewise offered to all carpenters and other handicraftsmen; and surgeons were offered the same conditions with the ensigns.—This proclamation was published in March, and by the month of May 3700 persons had offered themselves. They accordingly embarked, and established themselves in the bay of Chebucto; calling the city *Halifax*, from the title of their patron. Before the end of October the same year, 350 comfortable wooden houses were built, and as many more during the winter.—The same year in which the settlers embarked, the government granted them 40,000l. for their expences. In 1750, they granted 57,582l. 17s. 3½d. for the same purpose; in 1751, 53,927l. 14s. 4d.; in 1752, 61,492l. 19s. 4½d.; in 1753, 94,615l. 12s. 4d.; in 1754, 58,447l. 2s.; and in 1755, 49,418l. 7s. 8d.—The place at last attained a degree of splendor that seemed to rival the first cities in the United States; for this it has been equally indebted to the American war, to the great increase of population from the exiled loyalists, and the fostering care of Great Britain. About this time the number of inhabitants was more than doubled in ten years.

The harbour, which is well sheltered from all winds, is so spacious, that a thousand sail of ships may ride in safety. Upon it there are built a great number of commodious wharfs, which have from 12 to 18 feet water at all times of the tide, for the convenience of loading and unloading ships. The streets of the town are regularly laid out, and cross each other at right angles; the whole rising gradually from the water upon the side of a hill whose top is regularly fortified, but not so as to be able to withstand a regular attack. Many considerable merchants reside at this place, and are possessed of shipping to the amount of several thousand tons, employed in a flourishing trade both with Europe and the West Indies. There is a small but excellent careening yard for ships of the royal navy that are upon this station, or that may have occasion to come in to rest, and take water, fuel, or fresh provisions on board, in their passage

Halifax

Halifax. passage to and from the West Indies. It is always kept well provided with naval stores; and ships of the line are hove down and repaired with great ease and safety. Several batteries of heavy cannon command the harbour, particularly those that are placed upon George's island, which being very steep and high, and situated in mid-channel, a little way below the town, is well calculated to annoy vessels in any direction, as they must of necessity pass very near it before they are capable of doing any mischief. Above the careening yard, which is at the upper end of the town, there is a large bason, or piece of water, communicating with the harbour below, near 20 miles in circumference, and capable of containing the whole navy of England, entirely sheltered from all winds, and having only one narrow entrance, which, as we observed before, leads into the harbour. There are a number of detached settlements lately formed by the loyalists upon the bason; the lands at a small distance from the water being generally thought better than those near to Halifax; but what success may attend their labours, will require some time to determine. An elegant and convenient building has been erected near the town for the convalescence of the navy; but the healthiness of the climate has as yet prevented many persons from becoming patients. There is a very fine lighthouse, standing upon a small island just off the entrance of the harbour, which is visible, either by night or day, six or seven leagues off at sea. The population has been variously estimated from 8000 to 16,000. The imports from Great Britain in 1810 amounted to 600,000*l*.

HALIFAX, earl of. See **SAVILLE**.

HALIFAX, a town in the west riding of Yorkshire in England, seated on the river Calder, in W. Long. 1. 55. N. Lat. 53. 45. It has the title of an earldom, and is very eminent for the clothier trade. The parish is said to be the most populous, if not the most extensive, in England: for it is above 30 miles in circumference; and, besides the mother church at Halifax, and 16 meeting-houses, has 12 chapels, two of which are parochial. What is a little singular, all the meeting-houses here, except the Quakers, have bolls and burying grounds. The woollens principally manufactured here are kerseys and shalloons. Of the former it is affirmed, that one dealer hath sent by commission 60,000 pounds worth in a year to Holland and Hamburg; and of the latter, it is said, 100,000 pieces are made in this parish yearly. The inhabitants here and in the neighbouring towns are so entirely employed in these manufactures, that agriculture is but little minded. Most of their provisions of all sorts are brought from the north and east ridings, and from Lancashire, Cheshire, Nottinghamshire, and Warwickshire. The markets are very much crowded for the buying and selling provisions and manufactures. The cloths, at the first erecting of the woollen manufactures in these parts, having been frequently stolen off the tenters in the night, a law was made, by which the magistrates of Halifax were empowered to pass sentence on and execute all offenders, if they were taken in the fact, or owned it, or if the stolen cloth was found upon them, provided also the crime was committed, and the criminal apprehended, within the liberties of the forest of Hardwick. These found guilty

were executed in the following manner: an axe was drawn by a pulley to the top of a wooden engine, and fastened by a pin; which being pulled out, the axe fell down in an instant, and did its work. If they had stolen an ox, horse, or any other beast, it was led with them to the scaffold, and there fastened by a cord to the pin that held up the axe; and when the signal was given by the jurors, who were the first burghers within the several towns of the forest, the beast was driven away, and the pin plucked out, upon which the axe fell and did its office. This severe and summary course of justice is not now in use. See **MAIDEN** and **GUILLOTINE**.—The old parish church having been found too small, a new one, in the Grecian style, was erected in 1798. A large building called a *cloth hall*, for the sale of woollens has been lately erected. It contains 315 separate rooms for the reception of goods, of which 50,000*l*. worth are generally exposed at a time. The whole population of the parish in 1811 was 73,515, of which the town contained nearly 11,000.

HALIOTIS, the **EAR-SHELL**, a genus of shell-fish, belonging to the order of vermes testacea. See **CONCHOLOGY Index**.

HALITZ, a town of Poland, and capital of a territory of the same name, in Red Russia, with a castle. It is seated on the river Neister. E. Long. 26. 0. N. Lat. 49. 20.

HALL, in *Architecture*, a large room at the entrance of a fine house and palace. Vitruvius mentions three kinds of halls; the tetrastyle, with four columns supporting the platform or ceiling; the Corinthian, with columns all round let into the wall, and vaulted over; and the Egyptian, which had a peristyle of insulated Corinthian columns, bearing a second order with a ceiling.

The hall is properly the finest as well as first member of an apartment: and in the houses of ministers of state, magistrates, &c. is the place where they dispatch business, and give audience. In very magnificent buildings, where the hall is larger and loftier than ordinary, and placed in the middle of the house, it is called a *saloon*.

The length of a hall should be at least twice and a quarter its breadth; and in great buildings, three times its breadth. As to the height of halls, it may be two-thirds of the breadth; and, if made with an arched ceiling, it will be much handsomer, and less liable to accidents by fire. In this case, its height is found by dividing its breadth into six parts, five of which will be the height from the floor to the under side of the key of the arch.

HALL is also particularly used for a court of justice; or an edifice wherein there is one or more tribunals.

In Westminster-hall are held the great courts of England, viz. the king's bench, chancery, common pleas, and exchequer. In adjoining apartments is likewise held the high court of parliament.

Westminster-hall was the royal palace or place of residence of our ancient kings; who ordinarily held their parliaments, and courts of judicature, in their dwelling-houses (as is still done by the kings of Spain), and frequently sat in person in the courts of judicature as they still do in parliament. A great part of this palace was burnt under Henry VIII.; what remains is still re-

Hall
Hallein.

served for the said judicatories. The great hall, where-
in the courts of king's bench, &c. are kept, is said to
have been built by William Rufus; others say by
Richard I. or II. It is reckoned superior, in point of
dimensions, to any hall in Europe; being 300 feet
long and 100 broad.

HALL, *Joseph*, an eminent prelate of the church of
England, was born in 1574, and educated at Cam-
bridge. He became professor of rhetoric in that uni-
versity, and then successively was made rector of Hal-
sted, in Suffolk, presented to the living of Waltham in
Essex, made prebendary of Wolverhampton, dean of
Worcester, bishop of Exeter, and lastly of Norwich.
His works testify his zeal against Popery, and are much
esteemed. He lamented the divisions of the Protestants,
and wrote something concerning the means of putting an
end to them. July 1616, he attended the embassy of
Lord Doncaster into France, and upon his return was
appointed by his majesty to be one of the divines who
should attend him into Scotland. In 1618 he was sent
to the synod of Dort with other divines, and pitched up-
on to preach a Latin sermon before that assembly. But
being obliged to return from thence before the synod
broke up, on account of his health, he was by the states
presented with a gold medal. He wrote, 1. Miscella-
neous epistles. 2. *Mundus alter et idem*. 3. A just cen-
sure of travellers. 4. The Christian Seneca. 5. Satires,
in six books. 6. A century of meditations; and many
other works, which, besides the above satires, make in
all five volumes in folio and quarto. He died in 1656.

HALLAGE, a fee or toll paid for cloth brought to
be sold in Blackwell-hall, London.

HALLAMAS, in our old writers the day of all-
hallows; or all-saints, viz. November 1. It is one of
the cross quarters of the year, which was computed, in
ancient writings, from Hallamas or Candlemas.

HALLAND, a country of Sweden, in the island
of Schonen, lying along the sea-coast, at the entrance
of the Baltic sea, and opposite to Jutland. It is 60
miles along the coast, but it is not above 12 in breadth.
Halmstadt is the capital town.

HALLATON, a town of Leicestershire, in Eng-
land. It is seated on a rich soil, 12 miles south-east of
Leicester, in E. Long. 0. 50. N. Lat. 52. 35.

HALLE, a little dismantled town of the Nether-
lands, in Hainault. The church of Notre Dame con-
tains an image of the Virgin Mary, held in great veneration.
E. Long. 3. 15. N. Lat. 50. 44.

HALLE, a handsome and considerable town of Ger-
many, in the circle of Upper Saxony, and in the duchy
of Magdeburg, with a famous university and salt-works.
It belongs to the king of Prussia; and is seated in a
pleasant plain on the river Sale. The inhabitants
are stated at 25,000. E. Long. 12. 8. N. Lat. 51.
31.

HALLE, a free and imperial town of Germany, in
Suebia, famous for its salt-pits. It is seated on the
river Kocher, among rocks and mountains, in E. Long.
10. 50. N. Lat. 49. 6.

HALLEIN, a town of Germany, in the circle of
Bavaria, and archbishopric of Saltsburg; seated on the
river Saltza, among the mountains, wherein are mines
of salt, which are the chief riches of the town and
country. E. Long. 12. 15. N. Lat. 47. 33.

HALLELUJA, a term of rejoicing, sometimes sung Halleluja.
or rehearsed at the end of verses on such occasions.

The word is Hebrew; or rather, it is two Hebrew
words joined together: one of them הללה, *hallelu*, and
the other יהוה, *jah*; an abridgement of the name of God,
יהוה, *Jehovah*. The first signifies *laudate*, "praise ye;"
and the other, *Dominum*, "the Lord."

St Jerome first introduced the word hallelujah into
the church service: for a considerable time it was only
used once a-year in the Latin church, viz. at Easter;
but in the Greek church it was much more frequent.
St Jerome mentions its being sung at the interments
of the dead, which still continues to be done in that
church, as also on some occasions in the time of
Lent.

In the time of Gregory the Great, it was appointed
to be sung all the year round in the Latin church,
which raised some complaints against that pope; as giv-
ing too much into the Greek way, and introducing
the ceremonies of the church of Constantinople into
that of Rome. But he excused himself by alleging,
that this had been the ancient usage of Rome; and that
it had been brought from Constantinople at the time
when the word hallelujah was first introduced under
Pope Damascus.

HALLENBERG, a town of Germany, in West-
phalia, seven miles from Medebach, and 62 east of Co-
logne.

HALLENCOURT, a town of France, in the de-
partment of Somme, seven miles and a half south of
Abbeville.

HALLER, ALBERT VAN, an eminent physician,
was born at Bern, on the 16th of October 1708. He
was the son of an advocate of considerable eminence
in his profession. His father had a numerous family,
and Albert was the youngest of five sons. From the
first period of his education, he showed a very great
genius for literature of every kind: to forward the
progress of his studies, his father took into his family
a private tutor, named *Abraham Billedts*; and such was
the discipline exerted by this pedagogue, that the acci-
dental sight of him at any future period of life, ex-
cited in Haller very great uneasiness, and renewed all
his former terrors. According to the accounts which
are given us, the progress of Haller's studies, at the
earliest periods of life, was rapid almost beyond belief.
When other children were beginning only to read, he
was studying Bayle and Mereri; and at nine years of
age he was able to translate Greek, and was beginning
the study of Hebrew. Not long after this, however,
the course of his education was somewhat interrupted
by the death of his father; an event which happened
when he was in the 13th year of his age. After this
he was sent to the public school at Bern, where he ex-
hibited many specimens of early and uncommon genius.
He was distinguished for his knowledge in the Greek
and Latin languages; but he was chiefly remarkable
for his poetical genius: and his essays of this kind,
which were published in the German language, were
read and admired throughout the whole empire. In the
16th year of his age he began the study of medicine
at Tubingen, under those eminent teachers Durnovoy
and Camerarius; and continued there for the space of
two-years, when the great reputation of the justly ce-
lebrated

Haller.

Haller. **l**brated Boerhaave drew him to Leyden. Nor was this distinguished teacher the only man from whose superior abilities he had there an opportunity of profiting. Ruysch was still alive, and Albinus was rising into fame. Animated by such examples, he spent all the day, and the greatest part of the night, in the most intense study; and the proficiency which he made, gained him universal esteem both from his teachers and fellow students. From Holland, in the year 1727, he came to England. Here, however, his stay was but short; and it was rather his intention to visit the illustrious men of that period, than to prosecute his studies at London. He formed connexions with some of the most eminent of them. He was honoured with the friendship of Douglas and Cheselden; and he met with a reception proportioned to his merit from Sir Hans Sloane, president of the Royal Society. After his visit to Britain, he went to France; and there, under those eminent masters, Winslow and Le Dran, with the latter of whom he resided during his stay in Paris, he had opportunities of prosecuting anatomy, which he had not before enjoyed. But the zeal of our young anatomist was greater than the prejudices of the people at that period, even in the enlightened city of Paris, could admit of. An information being lodged against him to the police for dissecting dead bodies, he was obliged to cut short his anatomical investigations by a precipitate retreat. Still, however, intent on the farther prosecution of his studies, he went to Basil, where he became a pupil to the celebrated Bernouilli.

Thus improved and instructed by the lectures of the most distinguished teachers of that period, by uncommon natural abilities, and by unremitting industry, he returned to the place of his nativity in the 26th year of his age. Not long after this, he offered himself a candidate, first for the office of physician to an hospital, and afterwards for a professorship. But neither the character which he had before he left his native country, nor the fame which he had acquired and supported while abroad, were sufficient to combat the interest opposed to him. He was disappointed in both; and it was even with difficulty that he obtained, in the following year, the appointment of keeper of a public library at Bern. The exercise of this office was indeed by no means suited to his great abilities: but it was agreeable to him, as it afforded him an opportunity for that extensive reading by which he has been so justly distinguished. The neglect of his merit which marked his first outset, neither diminished his ardour for medical pursuits, nor detracted from his reputation either at home or abroad. Soon after he was nominated a professor in the university of Gottingen, by King George II. The duties of this important office he discharged, with no less honour to himself than advantage to the public, for the space of 17 years; and it afforded him an ample field for the exertion of those great talents which he possessed. Extensively acquainted with the sentiments of others respecting the economy of the human body, struck with the diversity of opinions which they held, and sensible that the only means of investigating truth was by careful and candid experiment, he undertook the arduous task of exploring the phenomena of human nature from the original source. In these pursuits he was no less industrious than successful, and there was hardly any function of the body on

Haller. **l** which his experiments did not reflect either a new or a stronger light. Nor was it long necessary for him, in this arduous undertaking, to labour alone. The example of the preceptor inspired his pupils with the spirit of industrious exertion. Zinn, Zimmerman, Caldani, and many others, animated by a generous emulation, laboured with indefatigable industry to prosecute and to perfect the discoveries of their great master. The mutual exertion of the teacher and his students, not only tended to forward the progress of medical science, but placed the philosophy of the human body on a more sure, and an almost entirely new basis. But the labours of Dr Haller, during his residence at Gottingen, were by no means confined to any one department of science. He was not more anxious to be an improver himself, than to instigate others to similar pursuits. To him, the Anatomical Theatre, the School of Midwifery, the Chirurgical Society, and the Royal Academy of Sciences at Gottingen, owe their origin. Such distinguished merit could not fail to meet with a suitable reward from the sovereign under whose protection he then taught. The king of Great Britain not only honoured him with every mark of attention which he himself could bestow, but procured him also letters of nobility from the emperor. On the death of Dillenius, he had an offer of the professorship of botany at Oxford; the states of Holland invited him to the chair of the younger Albinus; the king of Prussia was anxious that he should be the successor of Maspertuis at Berlin. Marshal Keith wrote to him in the name of his sovereign, offering him the chancellorship of the university of Halle, vacant by the death of the celebrated Wolff. Count Orlov invited him to Russia, in the name of his mistress the empress, offering him a distinguished place at St Petersburg. The king of Sweden conferred on him an unsolicited honour, by raising him to the rank of knighthood of the order of the polar star; and the emperor of Germany did him the honour of a personal visit; during which he thought it no degradation of his character to pass some time with him in the most familiar conversation.

Thus honoured by sovereigns, revered by men of literature, and esteemed by all Europe, he had it in his power to have held the highest rank in the republic of letters. Yet, declining all the tempting offers which were made to him, he continued at Gottingen, anxiously endeavouring to extend the rising fame of that medical school. But after 17 years residence in that university, an ill state of health rendering him less fit for the duties of the important office which he held, he solicited and obtained permission from the regency of Hanover to return to his native city of Bern. His fellow-citizens, who might at first have fixed him among themselves, with no less honour than advantage to their city, were now as sensible as others of his superior merit. A pension was settled upon him for life, and he was nominated at different times to fill the most important offices in the state. These occupations, however, did not diminish his ardour for useful improvements. He was the first president, as well as the greatest promoter, of the Oeconomical Society at Bern; and he may be considered as the father and founder of the Orphan Hospital of that city. Declining health, however, restrained his exertions in the more active

Haller
Halley.

scenes of life, and for many years he was confined entirely to his own house. Even this, however, could not put a period to his utility: for, with indefatigable industry, he continued his favourite employment of writing till within a few days of his death, which happened in the 70th year of his age, on the 12th of December 1777. His *Elementa Physiologiae* and *Bibliotheca Medicinæ*, will afford, to latest posterity, undeniable proofs of his indefatigable industry, penetrating genius, and solid judgment. But he was not more distinguished as a philosopher than beloved as a man; and he was not more eminent for his improvement in every department of medical science, than for his piety to God, and benevolence to all mankind.

HALLERIA, a genus of plants belonging to the didynamia class; and in the natural method ranking under the 40th order, *Personatae*. See BOTANY Index.

HALLEY, DR EDMUND, an eminent astronomer, was the only son of a soap-boiler in London, and was born in 1656. He first applied himself to the study of the languages and sciences, but at length gave himself up wholly to that of astronomy. In 1676, he went to the island of St Helena to complete the catalogue of fixed stars, by the addition of those which lie near the south pole; and having delineated a planisphere in which he laid them all down in their exact places, he returned to England in 1678. In the year 1680, he took what is called the *grand tour*, accompanied by his friend the celebrated Mr Nelson. In the midway between Calais and Paris, Mr Halley had a sight of a remarkable comet, as it then appeared a second time that year, in its return from the sun. He had the November before seen it in its descent; and now hastened to complete his observations upon it, in viewing it from the royal observatory of France. His design in this part of his tour was, to settle a friendly correspondence between the two royal astronomers of Greenwich and Paris; and in the mean time to improve himself under so great a master as Cassini. From thence he went to Italy, where he spent great part of the year 1681; but his affairs calling him home, he returned to England. In 1683, he published his *Theory of the variation of the magnetical compass*; in which he supposes the whole globe of the earth to be a great magnet, with four magnetical poles, or points of attraction: but afterwards thinking that this theory was liable to great exceptions, he procured an application to be made to King William, who appointed him commander of the Paramour pink, with orders to seek by observations the discovery of the rule of variations, and to lay down the longitudes and latitudes of his majesty's settlements in America.—He set out on this attempt on the 24th of November 1698: but having crossed the line, his men grew sickly; and his lieutenant mutinying, he returned home in June 1699. Having got the lieutenant tried and cashiered, he set sail a second time in September following, with the same ship, and another of less bulk, of which he had also the command. He now traversed the vast Atlantic ocean from one hemisphere to the other, as far as the ice would permit him to go; and having made his observations at St Helena, Brazil, Cape Verd, Barbadoes, the Madeiras, the Canaries, the coast of Barbary, and many other latitudes, arrived in September 1700; and the next year publish-

Halley
Halmote.

ed a general chart, showing at one view the variation of the compass in all those places. Captain Halley, as he was now called, had been at home little more than half a year, when he was sent by the king to observe the course of the tides, with the longitude and latitude of the principal head-lands in the British channel: which having executed with his usual expedition and accuracy, he published a large map of the British channel. Soon after, the emperor of Germany resolving to make a convenient harbour for shipping in the Adriatic, Captain Halley was sent by Queen Anne to view the two ports on the coast of Dalmatia. He embarked on the 22d of November 1702; passed over to Holland; and going through Germany to Vienna, he proceeded to Istria: but the Dutch opposing the design, it was laid aside; yet the emperor made him a present of a rich diamond-ring from his finger, and honoured him with a letter of recommendation, written with his own hand, to Queen Anne. Presently after his return, he was sent again on the same business; when passing through Hanover, he supped with King George I. then electoral prince, and his sister the queen of Prussia. On his arrival at Vienna, he was the same evening presented to the emperor, who sent his chief engineer to attend him to Istria, where they repaired and added new fortifications to those of Trieste. Mr Halley returned to England in 1703; and the same year was made professor of geometry in the university of Oxford, in the room of Dr Wallis, and had the degree of doctor of laws conferred on him by that university. He is said to have lost the professorship of astronomy in that city, because he would not profess his belief of the Christian religion. He was scarcely settled at Oxford, when he began to translate into Latin from the Arabic, *Apollonius de sectione rationis*; and to restore the two books *De sectione spatii* of the same author, which are lost, from the account given of them by Pappus; and he published the whole work in 1706. Afterwards he had a share in preparing for the press Apollonius's Conics; and ventured to supply the whole eighth book, the original of which is also lost. He likewise added Sereus on the section of the cylinder and cone, printed from the original Greek, with a Latin translation, and published the whole in folio. In 1713, he was made secretary of the Royal Society; in 1720, he was appointed the king's astronomer at the royal observatory at Greenwich, in the room of Mr Flamsteed; and, in 1729, was chosen as a foreign member of the Academy of Sciences at Paris. He died at Greenwich in 1742. His principal works are, 1. *Catalogus stellarum australium*. 2. *Tabulae astronomicae*. 3. An abridgement of the astronomy of comets, &c. We are also indebted to him for the publication of several of the works of the great Sir Isaac Newton, who had a particular friendship for him, and to whom he frequently communicated his discoveries.

HALLEY'S Quadrant. See QUADRANT.

HALLIARDS, the ropes or tackles usually employed to hoist or lower any sail upon its respective mast or stay. See JEARS.

HALMOTE, or HALIMOTE, is the same with what is now called a *court-baron*, the word implying a meeting of the tenants of the same hall or manor. The name is still retained at Luston, and other places in Herefordshire. See MOTE.

HALMSTADT.

HALMSTADT. See HELMSTADT.

HALO, or **CORONA**, in *Natural History*, a coloured circle appearing round the body of the sun, moon, or any of the large stars. See **CORONA**.

HALORAGUS, a genus of plants belonging to the octandria class. See **BOTANY Index**.

HALSTEAD, a town of Essex in England, seated on the river Coln, 45 miles from London. The town consists of about 600 houses, and the inhabitants are about 4000 in number. Here is a good manufactory of says, bays, callimancoes, &c. and its market is noted for corn.

HALT, in *War*, a pause or stop in the march of a military body.—Some derive the word from the Latin *halitus*, "breath;" it being a frequent occasion of halting to take breath: others from *alto*, because in halting they raised their pikes on end, &c.

HALTER, in the manege, a head-stall for a horse, of Hungary leather, mounted with one, and sometimes two straps, with a second throat-band, if the horse is apt to unhalter himself.

HALTER-Cast, is an excoriation of the pastern, occasioned by the halter's being entangled about the foot, upon the horse's endeavouring to rub his neck with his hinder feet. For the cure of this, anoint the place, morning and evening, with equal quantities of linseed oil and brandy, well mixed.

HALTERES, or **POISERS**, in *Entomology*, two small round bodies, supported on stalks and attached to the insect under the wings of dipterous flies, as in the *tipula* genus. They are supposed by some naturalists to be the rudiments of another pair of wings. See **ENTOMOLOGY**.

HALTERISTÆ, in antiquity, a kind of players at discus; denominated from a peculiar kind of discus, called by the Greeks *άλυσ*, and by the Latins *halter*. See **DISCUS**.

Some take the discus to have been a leaden weight or ball which the vaulters bore in their hands, to secure and keep themselves the more steady in their leaping. Others will have the halter to be a lump or mass of lead or stone, with an hole or handle fixed to it, by which it might be carried; and that the halteristæ were those who exercised themselves in removing these masses from place to place.

Hier. Mercurialis, in his treatise *De arte gymnastica*, l. ii. c. 12. distinguishes two kinds of halteristæ; for though there was but one halter, there were two ways of applying it. The one was to throw or pitch it in a certain manner; the other only to hold it out at arm's-end, and in this posture to give themselves divers motions, swinging the hand backwards and forwards, according to the engraven figures thereof given us by Mercurialis.—The halter was of a cylindrical figure, smaller in the middle where it was held, by one diameter, than at the two ends. It was above a foot long, and there was one for each hand: it was either of iron, stone, or lead.

Galen, *De tuend. valetud.* lib. i. v. and vi. speaks of this exercise, and shows of what use it is in purging the body of peccant humours; making it equivalent both to purgation and phlebotomy.

HALTON, or **HAULTON**, i. e. *High Town*, a town of Cheshire, 186 miles from London. It stands on a hill, where a castle was built anno 1071, and is a

member of the duchy of Lancaster; which maintains a large jurisdiction in the county round it, by the name of *Halton-Fee*, or the *honour of Halton*, having a court of record, prison, &c. within themselves. About Michaelmas every year, the king's officers of the duchy keep a law-day at the castle, which still remains a stately building. Once a fortnight a court is kept here, to determine all matters within their jurisdiction; but felons and thieves are carried to the sessions at Chester, to receive their sentence. By the late inland navigation, it has communication with the rivers Mersey, Dec, Ribble, Ouse, Trent, Darwent, Severn, Humber, Thames, Avon, &c.; which navigation, including its windings, extends above 500 miles, in the counties of Lincoln, Nottingham, York, Lancaster, Westmoreland, Stafford, Warwick, Leicester, Oxford, Worcester, &c. Population 894 in 1811.

HALTWHISTLE, a town of Northumberland in England, situated in W. Long. 2. 15. N. Lat. 55. 2.

HALYMOTE, properly signifies a holy or ecclesiastical court. See **HALMOTE**.

There is a court held in London by this name before the lord mayor and sheriffs, for regulating the bakers. It was anciently held on Sunday next before St Thomas's day, and for this reason called the *Halymote*, or *Holy-court*.

HALYS, in *Ancient Geography*, the noblest river of the Hither Asia, through which it had a long course, was the boundary of Croesus's kingdom to the east. Running down from the foot of Mount Taurus, through Cataonia, and Cappadocia, it divided almost the whole of the Lower Asia, from the sea of Cyprus down to the Euxine, according to Herodotus; who seems to extend its course too far. According to Strabo, himself a Cappadocian, it had its springs in the Great Cappadocia. It separated Paphlagonia from Cappadocia; and received its name *απο του αλας*, from salt, because its waters were of a salt and bitter taste, from the nature of the soil over which they flowed. It is famous for the defeat of Croesus king of Lydia, who was misled by the ambiguous word of this oracle:

Χροισος Ἄλυι διαβας μεγαλην αρχην διαλυσει.

If Croesus passes over the Halys, he shall destroy a great empire.

That empire was his own. See **CROESUS** and **LYDIA**.

HALYWERC FOLK, in old writers, were persons who enjoyed land, by the pious service of repairing some church, or defending a sepulchre.

This word also signified such persons in the diocese of Durham as held their lands to defend the corpse of St Cuthbert, and who from thence claimed the privilege of not being forced to go out of the bishopric.

HAM, or **CHAM**, in *Ancient Geography*, the country of the Zuzims (Gen. xiv. 5.), the situation whereof is not known.

HAM, the youngest son of Noah. He was the father of Cush, Mizraim, Phut, and Canaan; each whereof had the several countries peopled by them. With respect to Ham, it is believed that he had all Africa for his inheritance, and that he peopled it with his children. As for himself, it is thought by some that he dwelt in Egypt; but M. Basnage is rather of opinion, that neither Ham nor Mizraim ever were in

Halton
|
Ham.

Ham . Egypt, but that their posterity settled in this country, and called it by the name of their ancestors. And as to **Ham's** being worshipped as a god, and called *Jupiter Hammon*, he thinks people may have been led into this mistake by the similitude of names; and that *Jupiter Hammon* was the sun, to which divine honours have been paid at all times in Egypt. However that may be, Africa is called the land of Ham, in several places of the psalms, (Psal. lxxvii. 51. civ. 23. cv. 22.). In Plutarch, Egypt is called *Chemis*; and there are some footsteps of the name of *Ham* or *Cham* observed in *Psochemmis*, *Paitta-chemmis*, which are cantons of Egypt.

HAM, a Saxon word used for "a place of dwelling;" a village or town: hence the termination of some of our towns, *Nottingham*, *Buckingham*, &c. Also a home close, or little narrow meadow, is called a *ham*.

HAM is also part of the leg of an animal; being the inner or hind part of the knee, or the ply or angle in which the leg and thigh, when bent, incline to each other.

HAM, in *Commerce*, &c. is used for a leg or thigh of pork, dried, seasoned, and prepared, to make it keep, and to give it a brisk agreeable flavour.

Westphalia hams, which are so highly esteemed, are prepared by salting them with saltpetre, pressing them in a press eight or ten days, then steeping them in juniper-water, and drying them in the smoke of juniper-wood.

A ham may be salted in imitation of those of Westphalia, by sprinkling a ham of young pork with salt for one day, in order to fetch out the blood; then wiping it dry, and rubbing it with a mixture of a pound of brown sugar, a quarter of a pound of saltpetre, half a pint of bay salt, and three pints of common salt, well stirred together in an iron pan over the fire till they are moderately hot: let it lie three weeks in this salting, and be frequently turned, and then dry it in a chimney.

HAM, a city of Germany, in the circle of Westphalia, capital of the county of Mark, and subject to the king of Prussia. It is seated on the river Lippe, on the frontiers of Munster. The adjacent country abounds in corn, hemp, and flax; and the inhabitants get a good deal of money by travellers. It was formerly a Hanse town, but it is now reduced. E. Long. 7. 50. N. Lat. 51. 36.

HAM, a town of Picardy, in France, seated on the river Somme, among marshes. It has three parishes, and there is here a round tower whose walls are 36 feet thick. It was taken by the Spaniards in 1557, but restored by treaty. E. Long. 3. 9. N. Lat. 50. 11.

HAM, a village in Surrey, about a mile from Kingston, near which are the Ham Walks, so much celebrated by our admirable poet Thomson and others.

HAM, *West*, a village in Essex, where are the remains of an opulent abbey, founded in the year 1135. It is seated on the river Lea, four miles east of London.

HAMADAN. See **AMADAN**.

HAMADRYADES (formed of *ama*, together, and *dryas*, dryad, of *δρυς*, oak,) in antiquity, certain fabulous deities revered among the ancient heathens, and believed to preside over woods and forests, and to be in-

closed under the bark of oaks. The *hamadryades* were supposed to live and die with the trees they were attached to; as is observed by Servius on Virgil, *Eclog. x. ver. 62.* after *Mnesimachus*, the scholiast of *Apollonius*, &c. who mentions other traditions relating thereto.

The poets, however, frequently confound the *Hamadryads* with the *Naiads*, *Napeæ*, and rural nymphs in general; witness *Catullus*, *Carm. lxxviii. ver. 23.* *Ovid*, *Fast. iv. 229.* *Met. i. ver. 695. xiv. ver. 628.* *Propertius*, *Eleg. xx. 32.* *Virg. Ecl. x. ver. 64.* *Georg. iv. ver. 382, 383.* *Festus* calls them *Querquetulanae*, as being issued or sprung from oaks. An ancient poet, *Pherenicus*, in *Athenseus*, lib. iii. calls the vine, fig-tree, and other fruit-trees, *hamadryades*, from the name of their mother the oak.

This common idea among the ancients, of nymphs or intellectual beings annexed to trees, will account for their worshipping of trees; as we find they did, not only from their poets but their historians. *Livy* speaks of an ambassador's addressing himself to an old oak, as to an intelligent person and a divinity, lib. iii. § 25.

HAMAH, a town of Turkey in Asia, in Syria, situated in E. Long. 37. 10. N. Lat. 34. 45. By some travellers it is corruptly called *Amar* and *Aman*. Some mistake it for the ancient *Apamea*; but this is now called *Afamayah*, and is situated a day's journey from Hamah. Hamah is situated among hills, and has a castle seated on a hill. It has all along been a considerable place, and in the 13th century had princes of its own. It is very large, and being seated on the ascent of a hill, the houses rise above one another, and make a fine appearance. It is, however, like most other towns under the Turkish government, going to decay. Many of the houses are half ruined; but those which are still standing, as well as the mosque and castle, have their walls built of black and white stones, disposed in such a manner as to form various figures. The river *Assi*, the ancient *Oroetes*, runs by the side of the castle, and fills the ditches round it, which are cut very deep into the rock. This river, leaving the castle, passes through the town from south to north, and has a bridge over it, though it is pretty broad. In its course through the town it turns 18 great wheels, called by the natives *saki*, which raise great quantities of water to a considerable height, and throw it into canals supported by arches, by which means it is conveyed into the gardens and fountains. There are some pretty good bazars or market-places in Hamah, where there is a trade for linen, which is manufactured there, and sent to Tripoli to be exported into Europe.

HAMAMELIS, **WITCH-HAZEL**; a genus of plants belonging to the tetrandria class; and in the natural method ranking with those of which the order is doubtful. See **BOTANY Index**.

HAMAM LEEP, a town 12 miles east from Tunis, noted for its hot baths, which are much resorted to by the Tunisians, and are efficacious in rheumatism and many other complaints. Here the bey has a very fine bath, which he frequently permits the consuls and other persons of distinction to use.

HAMATH, a city of Syria, capital of a province of the same name, lying upon the *Oroetes*. "The entering into Hamath," which is frequently spoken of

Hamath
Hambden.

in Scripture, (Josh. xiii. 5. Judges iii. 3. 2 Kings xiv. 25. and 2 Ch. vii. 8.) is the narrow pass leading from the land of Canaan through the valley which lies between Libanus and Antilibanus. This entrance into Hamath is set down as the northern boundary of the land of Canaan, in opposition to the southern limits, the Nile or river of Egypt. Josephus, and St Jerome after him, believed Hamath to be Epiphania. But Theodoret and many other good geographers maintain it to be Emesa in Syria. Joshua (xix. 35.) assigns the city of Hamath to the tribe of Naphtali. Toi king of Hamath cultivated a good understanding with David, (2 Sam. viii. 9.). This city was taken by the kings of Judah, and retaken from the Syrians by Jeroboam the second, (2 Kings xiv. 28.). The kings of Assyria made themselves masters of it upon the declension of the kingdom of Israel, and transplanted the inhabitants of Hamath into Samaria, (2 Kings xvii. 24. and xviii. 34. &c.).

HAMAXOBII, HAMAXOBIANS, in the ancient geography, a people who had no houses, but lived in carriages. The word is formed from *ἡμαξα*, a carriage or chariot, and *βίος*, life.

The *Hamaxobii*, called also *Hamaxobitæ*, were an ancient people of Sarmatia Europæa, inhabiting the southern part of Muscovy, who instead of houses had a sort of tents made of leather, and fixed on carriages to be ready for shifting and travel.

HAMB DEN, JOHN, a celebrated patriot, descended of the ancient family of Hambden in Buckinghamshire, was born in 1594. From the university he went to the inns of court, where he made considerable progress in the study of the law. He was chosen to serve in the parliament which began at Westminster Feb. 5. 1626; and served in all the succeeding parliaments in the reign of Charles I. In 1636 he became universally known, by his refusal to pay ship-money, as being an illegal tax; upon which he was prosecuted. His conduct throughout this transaction gained him a great reputation. When the long parliament began, the eyes of all men were fixed on him as their *pater patriæ*. On January 3. 1642, the king ordered articles of high treason and ether misdemeanours to be prepared against Lord Kimbolton, Mr Hambden, and four other members of the house of commons, and went to that house to seize them: but they had retired. Mr Hambden afterwards made a speech in the house to clear himself of the charge laid against him. In the beginning of the wars he commanded a regiment of foot, and did good service to the parliament at the battle of Edgehill. He received a mortal wound in an engagement with Prince Rupert, in Chalgrave-field in Oxfordshire, and died in 1643. He is said to have possessed the Socratic art in a high degree, of interrogating, and under the notion of doubts, insinuating objections, so that he infused his own opinions into those from whom he pretended to learn and receive them. He was, say his panegyrists, a very wise man and of great parts; and had the greatest talents for popularity that were ever possessed by any man: He was master over all his appetites and passions, and had thereby a very great ascendant over other men's: He was of an industry and vigilance never to be tired out, of parts not to be imposed upon by the most subtle, and of courage equal to his best parts.

VOL. X. Part I.

HAMBURG, an imperial city of Germany, seated in E. Long. 9. 55. N. Lat. 53. 36. Its name is derived from the old German word *Hamme*, signifying a wood, and *Burg*, a castle; and stands on the north side of the river Elbe. This river is not less than four miles broad opposite the city. It forms two spacious harbours, and likewise runs through most part of it in canals. It flows above Hamburg many miles; but when the tide is accompanied with north-west winds, a great deal of damage is done by the inundations occasioned thereby. There are a great many bridges over the canals, which are mostly on a level with the streets, and some of them have houses on both sides. In the year 833, Ludovicus Pius erected Hamburg first into a bishopric, and afterwards into an archbishopric; and Adolphus III. duke of Saxony, among many other great privileges, granted it the right of fishing in the Elbe, eight miles above and below the city. The kings of Denmark, since they have succeeded to the counts of Holstein, have continually claimed the sovereignty of this place, and often compelled the citizens to pay large sums to purchase the confirmation of their liberties. Nay, it has more than once paid homage to the king of Denmark; who, notwithstanding, keeps a minister here with credentials, which is a sort of acknowledgment of its independency and sovereignty. Though Hamburg has been constantly summoned to the diet of the empire ever since the year 1618, when it was declared a free imperial city by a decree of the aulic council; yet it waves this privilege, in order to keep fair with Denmark. By their situation among a number of poor princes, the Hamburgers are continually exposed to their rapaciousness, especially that of the Danes, who have extorted vast sums from them. The city is very populous in proportion to its bulk; and in 1816 was estimated to contain 115,000 inhabitants, exclusive of 15,000 in the neighbouring territory under its authority. Here are a great many charitable foundations, the regulations of which are greatly admired by foreigners. All persons found begging in the streets are committed to the house of correction to hard labour, such as the rasping of Brazil and other kinds of wood. There is an hospital into which unmarried women may be admitted for a small sum, and comfortably maintained during the residue of their lives. The number of hospitals in this place is greater in proportion to its extent than in any other Protestant city in Europe. The revenue of the orphan-house alone is said to amount to between 50 and 60,000l. There is a large sumptuous hospital for receiving poor travellers that fall sick. In one of their work-houses or houses of correction, those who have not performed their task are hoisted up in a basket over the table in the common hall while the rest are at dinner, that they may be tantalized with the sight and smell of what they cannot taste. The established religion of Hamburg is Lutheranism; as for the Calvinists and the Roman Catholics, they go to the ambassadors chapels to celebrate their divine service and worship. They have here what they call a *private confession*, previous to the holy communion, which differs in nothing from that of the church of England, and the absolution is the same, only the poorest of the people here are forced to give a fee to the priests on these occasions.

G g

Hamburg. casions. Their churches, which are ancient large fabrics, are open thoroughfares, and in some of them there are booksellers shops. The pulpit of St Catherine's is of marble, curiously carved and adorned with figures and other ornaments of gold; and its organ, reckoned one of the best in Europe, has 6000 pipes. The cathedral is very ancient, and its tower leans as if just going to fall; yet, on account of the singularity and beauty of its architecture, the danger attending it has been hitherto overlooked. There is still a dean and chapter belonging to this church, though secularized; from whose court there lies no appeal, but to the imperial chamber at Wetziar. The chapter consists of a provost, dean, 13 canons, 8 minor canons, and 30 *vicarii immunes*, besides others who are under the jurisdiction of the city. The cathedral, with the chapter, and a number of houses belonging to them, were formerly under the immediate protection of his Britannic majesty as duke of Bremen, who disposes of the prebends that fall in six months of the year, not successively, but alternately with the chapter. Hamburg is almost of a circular form, and six miles in compass. It has six gates, and three entrances by water, viz. two from the Elbe and one from the Alster, being divided into the old and new, which are strongly fortified with moats, ramparts, bastions, and outworks. The ramparts are very lofty and planted with trees; a great part of which, however, were cut down in 1813 by the French. In the new town, towards Altena, are several streets of mean houses inhabited by Jews. Through that entrance from the Elbe, called the *lower Baum*, pass all ships going to or coming from sea. Every morning, at the opening of it, is seen a multitude of boats and small barks, whose cargoes consist of milk, fruits, and all kinds of provisions, rushing in at the same time. There are some fine chimies here, especially those of St Nicholas, which play every morning early, at one o'clock in the afternoon, and on all festivals and solemnities. The other public structures in this city, besides the churches, make no great appearance: however, the yard, arsenal, and two armories, are well worth seeing. There are several convents or cloisters still remaining; which having been secularized, are now possessed by the Lutherans. One of them holds its lands by this tenure, "That they offer a glass of wine to every malefactor who is carried by it for execution."

There is a fine exchange, though inferior to that of London. But it was found that the merchants could not be accommodated with every necessary convenience in transacting their business. To supply these defects a new Exchange Hall has been built. This structure is situated near the exchange, in the street called *Bohnenstrasse*. The facade is in a style of great elegance, and the entrance has three arcades supported by pillars of the Doric order. The steps run the whole breadth of the arcades, the intervals between which are ornamented with genii holding garlands of fruits and flowers. The doors leading to the ground floor of the building are on the right and left of the steps. The porter's lodge is on the right, and the door leading to the ball and concert room in the second story, is on the left. The balcony is vaulted and measures 22 feet in diameter. The facade is terminated by the third or attic story, which is provided with a row of Doric pilasters, above which there is a pediment.

Hamburg. The entrance into the hall is behind the central arcade, which is ornamented with a row of single statues, and measures 84 feet by 42. It is appropriated to the meeting of merchants and men of business. There are several other saloons or apartments, such as the Egyptian saloon surrounded with columns of granite, between which are landscapes in the manner of a panorama; and the underwriters have two rooms adjoining to this. The reading-room is furnished with all kinds of newspapers and periodical works from every quarter of the globe. The library is to contain all books necessary for commerce, in every language, to collect which must be the work of time. There is an anti-room with embellishments to the left of the great staircase.

The hall of arts is well adapted to the meetings of artists, which ought never to be wanting in establishments of such a nature. Here are five excellent pictures representing poetry, painting, sculpture, architecture, and music, together with the portraits of many celebrated men who have distinguished themselves in the arts. The ball and concert room measures 64 feet by 42, and the roof is 30 feet high. The gallery is supported by 18 pillars or columns of the Composite order, and the access to it is by the great staircase. The ceiling represents the firmament studded with stars, and Aurora dispersing the shades of night. There is also an Arabic, Turkish, and Grecian saloon, which the subscribers are at liberty to use as they please. The two spacious dining rooms may be thrown into one, when necessity requires it. They are ornamented with basso relievos in plaster of Paris.

The saloon of the muses and the musical saloon are on the third floor. A large room, in form of a rotunda, receives light from above, and may be considered as an academy of the imitative arts. A complete apparatus for expeditious printing also belongs to this magnificent fabric, under the direction of Mr Conrad Muller, an eminent printer in Hamburg, whose attention will be chiefly directed to the publishing of books on mercantile subjects. The whole edifice is finished in a style of great elegance and taste, and the management given to one who is fully qualified for the office.

It is the custom of Hamburg, that a citizen, when he dies, must leave the tenth of his estate to the city; and foreigners, not naturalized, must pay a certain sum annually for liberty to trade. The common carts here are only a long pulley laid upon an axle-tree between two wheels, and drawn not by horses, but by men, of whom a dozen or more are sometimes linked to these machines, with slings across their shoulders. Such of the senators, principal elders, divines, regular physicians, and graduates in law, as assist at funerals, have a fee. The hangman's house is the common prison for all malefactors; on whom sentence is always passed on Friday, and on Monday they are executed. As, by their laws, no criminal is punishable unless he plead guilty, they have five different kinds of torture to extort such confession. The government of this city is lodged in the senate and three colleges of burghers. The former is vested with almost every act of sovereignty, except that of laying taxes and managing the finances, which are the prerogatives of the latter. The magistracy is composed of four burgomasters, four syndics, and 24 aldermen, of whom some are lawyers and some merchants. Any person elected into the magistracy,

Hamburg. stracy, and declining the office, must depart the place. No burgher is admitted into any of the colleges, unless he dwells in a house of his own within the city, and is possessed of 1000 rixdollars in specie, above the sum for which the house may be mortgaged; or 2000 in moveable goods, within the jurisdiction of the same. For the administration of justice, here are several inferior courts, from which an appeal lies to the Obergericht, or high court, and from that to the aulic council and other imperial colleges. For naval causes here is a court of admiralty, which, jointly with the city-treasury, is also charged with the care of the navigation of the Elbe, from the city to the river's mouth. In consequence of this, 100 large buoys, some white, others black, are kept constantly floating in the river in summer: but in winter, instead of some of them, there are machines, like those called *ice-beacons*, to point out the shoals and flats. Subordinate to the admiralty is a company of pilots: and at the mouth of the Elbe is, or at least ought to be, a vessel always riding, with pilots ready to put on board the ships. At the mouth of the river also is a good harbour, called *Cushaven*, belonging to Hamburg; a light-house; and several beacons, some of them very large. For defraying the expence of these, certain tolls and duties were formerly granted by the emperors to the city. Besides the Elbe, there is a canal by which a communication is opened with the Trave, and thereby with Lubeck and the Baltic, without the bazard, trouble, and expence, of going about by the Sound. The trade of Hamburg is very extensive, in exporting all the commodities and manufactures of the several cities and states of Germany, and supplying them with whatever they want from abroad. Its exports consist of linens of several sorts and countries; as lawns, diapers, osnaburgs, dowlas, &c. linen-yarn, tin-plates, iron, brass, and steel-ware, clap-board, pipe-staves, wainscot-boards, oak-plank, and timber, kid-skins, corn, beer in great quantities, with flax, honey, wax, aniseed, linseed, drugs, wine, tobacco, and metals. Its principal imports are the woollen manufactures and other goods of Great Britain, to the amount of several hundred thousand pounds a-year: they have also a great trade with Spain, Portugal, and Italy, which is carried on mostly in English bottoms, on account of their Mediterranean passes. Their whale-fishery is also very considerable, 50 or 60 ships being generally sent out every year in this trade. Add to these a variety of manufactures, which are performed here with great success; the chief of which are, sugar-baking, calico-printing, the weaving of damasks, brocades, velvets, and other rich silks. The inland trade of Hamburg is superior to that of any in Europe, unless perhaps we should except that of Amsterdam and London. There is a paper published here at stated times called the *Preiscourant*, specifying the course of exchange, with the price which every commodity and merchandise bore last upon the exchange. There is also a board of trade, erected on purpose for the advancing every project for the improvement of commerce. Another great advantage to the merchant is, the bank established in 1619, which has a flourishing credit. To supply the poor with corn at a low price, here are public granaries, in which great quantities of grain are laid up. By charters from several emperors, the Hamburgers have a right of

coinage, which they actually exercise. The English merchants, or *Hamburg Company*, as it is called, enjoy great privileges; for they hold a court with particular powers, and a jurisdiction among themselves, and have a church and minister of their own.—This city has a district belonging to it of considerable extent, which abounds with excellent pastures, intermixed with several large villages and noblemen's seats. A small bailiwick, called *Bergedorf*, belongs to this city and Lubeck. There is a *schola illustris* or gymnasium here, well endowed, with six able professors, who read lectures in it as at the universities. There are also several free schools, and a great number of libraries, public and private. The public cellar of this town has always a prodigious stock and vent of old hock, which brings in a considerable revenue to the state. Besides the militia or trained bands, there is an establishment of 12 companies of infantry, and one troop of dragoons, besides an artillery company, and a night-guard. Hamburg was occupied by the French in 1806, and was incorporated with Napoleon's empire in 1810, forming the capital of the department of the mouths of the Elbe. It suffered greatly from Bonaparte's commercial prohibitory decrees, and from the destruction of property occasioned by Davoust's preparations to defend it against the allies. It was evacuated in March 1814, and is one of the four cities which were allowed votes in the diet of the empire by the congress of Vienna.

HAMEL, JOHN BAPTISTE DU, a very learned French philosopher and writer in the 17th century. At 18 he wrote a treatise, in which he explained in a very simple manner Theodosius's three books of Spherics; to which he added a tract upon trigonometry, extremely perspicuous, and designed as an introduction to astronomy. Natural philosophy, as it was then taught, was only a collection of vague, puzzling, and barren questions; when our author undertook to establish it upon right principles, and published his *Astronomia Physica*. In 1666 M. Colbert proposed to Louis XIV. a scheme, which was approved of by his majesty, for establishing a royal academy of sciences; and appointed our author secretary of it. He published a great many books; and died at Paris in 1706, of mere old age, being almost 83. He was regius professor of philosophy, in which he was succeeded by M. Varignon. He wrote Latin with purity and elegance.

HAMELIN, a strong town of Germany, in the duchy of Calemburg in Lower Saxony. It is situated at the extremity of the duchy of Brunswick, to which it is the key, near the confluence of the rivers Hamel and Weser, in E. Long. 9. 36. N. Lat. 52. 6.

HAMELLIA, a genus of plants belonging to the pentandria class; and in the natural method ranking with those of which the order is doubtful. See **BO-TANY Index**.

HAMESECKEN. Burglary, or nocturnal house-breaking, was by the ancient English law called *Hame-secken*, as it is in Scotland to this day.

HAMI, or **HA-MI**, a country of Asia, subject to the Chinese. It is situated to the north-east of China, at the extremity of that desert which the Chinese call *Chamo*, and the Tartars *Cobi*; and is only 90 leagues distant from the most westerly point of the province of Chensi. This country was inhabited in the early ages

Hami

by a wandering people named *Iong*. About the year 950 before the Christian era, they sent deputies to pay homage to the emperor of China, and presented some sabres by way of tribute. The civil wars by which China was torn about the end of the dynasty of Tcheou having prevented assistance from being sent to these people, they fell under the dominion of the Hieng-nou, who appear to have been the same as the Huns, and who at that time were a formidable nation. The Chinese several times lost and recovered the country of Hami. In 131 (the sixth year of the reign of Chunty, of the dynasty of the eastern Han), the emperor kept an officer there in quality of governor. Under the following dynasties, the same vicissitudes were experienced: Hami was sometimes united to the province of Chensi, sometimes independent of it, and sometimes even of the whole empire. The situation of these people (separated by vast deserts from China, to which, besides, they had no relation, either in language, manners, or customs) must have greatly contributed to facilitate these revolutions. All the tributary states of the empire having revolted in 610, that of Hami followed their example; but it again submitted to the yoke under Tai-tsong, second emperor of the dynasty of Tang, who had sent one of his generals with an army to reduce it. This great prince paid particular attention to his new conquest. He divided it into three districts, and connected its civil and military government in such a manner to that of the province of Chensi and other neighbouring countries, that tranquillity prevailed there during his reign and several of those that followed. Through Hami all the caravans which went from the west to China, or from China to the west, were obliged to pass. The emperors, predecessors of Tai-tsong, were satisfied with causing wine to be transported from Hami in skins carried by camels; but "Tai-tsong (says the Chinese history) having subdued the kingdom of Hami, ordered some vine-plants of the species called *majou*, to be brought him, which he caused to be planted in his gardens: he, besides, learned the manner of making wine, the use of which proved both serviceable and hurtful to him." Luxury and effeminacy having weakened the dynasty of Tang, the Mahometans (who had made a rapid progress in all the countries that are situated between Persia, Cobi, and the Caspian sea) advanced as far as Hami, which they conquered. It appears, that this country afterwards had princes of its own, but dependent on the Tartars, who successively ruled these immense regions. The Yuen or Mogul Tartars again united the country of Hami to the province of Chensi; and this reunion subsisted until 1360, at which time the emperor formed it into a kingdom, on condition of its princes doing homage and paying tribute. The king of Hami was honoured with a new title in 1404, and obtained a golden seal. After a contest of several years for the succession to the throne, the kingdom of Hami fell a prey to the king of Tou-eulh-fan. This yoke soon became uneasy to the people of Hami: they revolted from their new masters, and made conquests from them in their turn. The new king whom they made choice of did not long possess the throne: he was conquered and killed in a bloody battle which he fought with the king of Tou-eulh-fan, who also perished some time after.

Hami

Since this epocha, the country of Hami has been successively exposed to anarchy, or governed by its own princes. The prince who filled the throne in 1696 acknowledged himself a vassal of the empire, and sent as tribute to Peking camels, horses, and sabres. Kanghi received his homage with the usual ceremonies, and published a diploma, which established the rank that the king of Hami should hold among the tributary princes, the time when he should come to render homage, the nature of the presents necessary for his tribute, the number of auxiliaries he was bound to furnish in time of war, and the manner of his appointing a successor. All these regulations have subsisted till this time.

The country of Hami, though surrounded by deserts, is accounted one of the most delightful in the world. The soil produces abundance of grain, fruits, leguminous plants, and pasture of every kind. The rice which grows here is particularly esteemed in China; and pomegranates, oranges, peaches, raisins, and prunes, have a most exquisite taste; even the jujubes are so juicy, and have so delicious a flavour, that the Chinese call them *perfumed jujubes*. There is no fruit more delicate or more in request than the melons of Hami, which are carried to Peking for the emperor's table. These melons are much more wholesome than those of Europe; and have this singular property, that they may be kept fresh during great part of the winter.—But the most useful and most esteemed production of this country is its dried raisins. These are of two kinds: The first, which are most used in the Chinese medicine, seem to have a perfect resemblance to those known in Europe by the name of Corinthian. The second, which are in much greater request for the table, are smaller and more delicate than those of Provence. The Chinese authors perfectly agree with Messrs Lemery and Geoffroy, respecting the virtue and qualities of these dried grapes or raisins; but they attribute so much more efficacy to those of Hami than to those of China, that they prescribe them in smaller doses. They observe, that an infusion of the first is of great service in facilitating an eruption of the small-pox about the fourth day, when the patient either is or seems to be too weak; and to promote a gentle perspiration in some kinds of pleurisies or malignant fevers. The dose must be varied according to the age, habit of body, and strength of the patient; great care must be taken to administer this remedy seasonably and with judgment. The emperor caused plants to be transported from Hami to Peking, which were immediately planted in his gardens. As these plants were cultivated with extraordinary care, under his own eyes, they have perfectly succeeded. The raisins produced by them are exceedingly sweet, and have a most exquisite flavour.

Although the country of Hami (the latitude of which is 42° 53' 20") lies farther towards the north than several of the provinces of France, we are assured that its climate is more favourable to the culture of vines, and that it gives a superior degree of quality to the grapes. It never rains at Hami; even dews and fogs are scarcely ever seen there; the country is watered only by the snow which falls in winter, and by the water of this snow when melted, which is collected at the bottoms of the mountains, and preserved with

great

Hami,
Hamilton

great care and industry. The method of drying grapes in Hami is much simpler than that practised in the provinces of China. The people of Chensi hold them over the steam of hot wine, and even sometimes boil them a few seconds in wine in which a little clarified honey has been diluted. In the kingdom of Hami they wait until the grapes are quite ripe; they then expose them to the scorching rays of the sun; afterwards pick them, and leave them in that manner until they are quite dry. However dry these grapes may be, they become shrivelled, without losing any of their substance, and without growing flat: good raisins ought to be almost as crisp as sugar candy.

The kingdom of Hami contains a great number of villages and hamlets; but it has properly only one city, which is its capital, and has the same name. It is surrounded by lofty walls, which are half a league in circumference, and has two gates, one of which fronts the east, and the other the west. These gates are exceedingly beautiful, and make a fine appearance at a distance. The streets are straight, and well laid out; but the houses (which contain only a ground-floor, and which are almost all constructed of earth) make very little show: however, as this city enjoys a serene sky, and is situated in a beautiful plain, watered by a river, and surrounded by mountains which shelter it from the north winds, it is a most agreeable and delightful residence. On whatever side one approaches it, gardens may be seen which contain every thing that a fertile and cultivated soil can produce in the mildest climates. All the surrounding fields are enchanting: but they do not extend far; for on several sides they terminate in dry plains, where a number of beautiful horses are fed, and a species of excellent sheep, which have large flat tails that sometimes weigh three pounds. The country of Hami appears to be very abundant in fossils and valuable minerals: the Chinese have for a long time procured diamonds and a great deal of gold from it; at present it supplies them with a kind of agate, on which they set a great value. With regard to the inhabitants of this small state, they are brave, capable of enduring fatigue, very dexterous in all bodily exercises, and make excellent soldiers; but they are fickle and soon irritated, and when in a passion they are extremely ferocious and sanguinary.

HAMILTON, a town of Scotland, in Clydesdale, seated on the river Clyde, eleven miles south-east of Glasgow; from whence the noble family of Hamilton take their name, and title of duke. The town is seated in the middle of a very agreeable plain; on one side of which the Hamilton family has a large park, which is near seven miles in circumference, enclosed with a high wall, and well stocked with fallow deer. The rivulet called *Avon* runs through the park, and falls into the river Clyde, over which last there is a bridge of free-stone. W. Long. 4. 16. N. Lat. 55. 58. The original name of this place, or the lands about it, was *Cadzow* or *Cadyow*, a barony, granted to an ancestor of the noble owner, on the following occasion. In the time of Edward II. lived *Sir Gilbert de Hamilton*, or *Hampton*, an Englishman of rank; who happening at court to speak in praise of Robert Bruce, received on the occasion an insult from John de Spenser, chamberlain to the king, whom he fought and slew. Dreading the resentment of that potent family, he fled to the Scottish monarch;

who received him with open arms, and established him at the place possessed by the duke of Hamilton. In aftertimes the name was changed from *Cadzow* to *Hamilton*: and in 1445 the lands were erected into a lordship, and the proprietor Sir James sat in parliament as Lord Hamilton. The same nobleman founded the collegiate church at Hamilton in 1451, for a provost and several prebendaries. The endowment was ratified at Rome by the pope's bull, which he went in person to procure.—Hamilton house or palace is at the end of the town; a large heavy pile, with two deep wings at right angles with the centre: the gallery is of great extent; and furnished, as well as some other rooms, with excellent paintings. Population 6453 in 1811.

HAMILTON, *Anthony*, Count of, was descended from a younger branch of the dukes of Hamilton, and born in Ireland about the year 1646. His mother was sister to the duke of Ormond, then viceroy of that country. The troubles of that period compelled his family to retire to France while he was only an infant, and he was brought up in the language and religion of that country. He made different visits to England in the reign of Charles II. but he was prevented from obtaining any public employment in consequence of his religious opinions, to which he constantly adhered. He received from James II. a regiment of infantry in Ireland; but when that monarch's affairs came to be in a ruined condition, Count Hamilton accompanied him back to France, which he never afterwards quitted. On account of his wit and politeness he was very much admired, as well as for the many estimable qualities of his heart. His writings are lively, yet his conversation was serious, and he perhaps indulged too much his propensity to satire. He died in the year 1720 in the 74th year of his age.

The works of the count in the French language were printed in 6 vols. 12mo. in 1749, which consist of poems, fairy tales, and his *Memoirs of Count Grammont*, the best of all his compositions, of which Voltaire said, "it is of all books that in which the most slender ground-work is set off with the gayest, most lively and agreeable style." A splendid edition of it, adorned with fine engravings from original portraits, was published by the late Lord Orford, at his own private press.

HAMILTON, *George*, earl of Orkney, and a brave warrior, was the fifth son of William earl of Selkirk, and early betook himself to the profession of arms. Being made colonel in 1689-90, he distinguished himself by his bravery at the battle of the Boyne; and soon after, at those of Aghrim, Steinkirk, and Landen, and at the sieges of Athlone, Limerick, and Namur. His eminent services in Ireland and Flanders, through the whole course of the war, recommended him so highly to King William III. that, in 1696, he advanced him to the dignity of a peer of Scotland, by the title of *earl of Orkney*; and his lady, the sister of Edward Viscount Villiers, afterwards earl of Jersey, had a grant made to her, under the great seal of Ireland, of almost all the private estates of the late King James, of very considerable value.

Upon the accession of Queen Anne to the throne, he was promoted, in 1702, to the rank of major-general, and the next year to that of lieutenant-general, and was likewise made knight of the Thistle. His lord-

Hamilton.

Hamilton, ship afterwards served under the great duke of Marlborough; and contributed by his bravery and conduct to the glorious victories of Blenheim and Malplaquet, and to the taking several of the towns in Flanders.

Hamlet. In the beginning of 1710, his lordship, as one of the 16 peers of Scotland, voted for the impeachment of Dr Sacheverel; and the same year was sworn of the privy-council, and made general of the foot in Flanders. In 1712, he was made colonel of the royal regiment of fusileers, and served in Flanders under the duke of Ormond. In 1714, he was appointed gentleman-extraordinary of the bed-chamber to King George I. and afterwards governor of Virginia. At length he was appointed constable, governor, and captain of Edinburgh castle, lord-lieutenant of the county of Clydesdale, and field-marshal. He died at his house in Albemarle-street, in 1737.

HAMILTON, John, the 24th bishop of St Andrew's, to which he was translated from Dunkeld. He was natural son of James the first earl of Arran, and was in great favour at court whilst his friends remained in power. He was one of Queen Mary's privy council, and a steady friend to that unfortunate princess. He performed the ceremony of christening her son, and was at different times lord privy seal and lord treasurer. The queen had reason to lament her not following the advice of this prelate, after the fatal battle of Langside, viz. not to trust her person in England. By the regent earl of Murray, he was declared a traitor, and obliged to seek shelter among his friends. He was unfortunately in the castle of Dumbarton when that fortress was taken by surprise, from whence he was carried to Stirling, where on April 1. 1570, he was hanged on a live tree. The two following sarcastic verses were written upon this occasion:

*Vive diu, felix arbor, semperque vireto
Frondebis, ut nobis talia poma feras.*

HAMLET, HAMEL, or Hampsel, (from the Saxon *ham*, i. e. *domus*, and the German *let*, i. e. *membrum*), signifies a little village, or part of a village or parish; of which three words the first is now only used, though Kitchen mentions the two last. By Spelman there is a difference between *villam integram*, *villam dimidiam*, and *hamletam*; and Stow expounds it to be the seat of a freeholder. Several county-towns have hamlets, as there may be several hamlets in a parish; and some

particular places may be out of a town or hamlet, though not out of the county. **Hamlet.**

HAMLET, a prince celebrated in the annals of Denmark; and whose name has been rendered familiar in this country, and his story interesting, by being the subject of one of the noblest tragedies of our immortal Shakespeare.—Adjoining to a royal palace, which stands about half a mile from that of Cronborg in Elsinour, is a garden, which, Mr Coxe informs us, is called Hamlet's Garden, and is said by tradition to be the very spot where the murder of his father was perpetrated. The house is of modern date, and is situated at the foot of a sandy ridge near the sea. The garden occupies the side of the hill, and is laid out in terrasses rising one above another. Elsinour is the scene of Shakespeare's Hamlet; and the original history from which our poet derived the principal incidents of his play is founded upon facts, but so deeply buried in remote antiquity that it is difficult to discriminate truth from fable. Saxo-Grammaticus, who flourished in the 12th century, is the earliest historian of Denmark that relates the adventures of Hamlet. His account is extracted, and much altered, by Belleforest a French author; and an English translation of whose romance was published under the title of the *Historye of Hamlet*: and from this translation Shakespeare formed the ground-work of this play, though with many alterations and additions. The following short sketch of Hamlet's history, as recorded in the Danish annals, will enable the reader to compare the original character with that delineated by Shakespeare.

Long before the introduction of Christianity into Denmark, Horwendillus, prefect or king of Jutland, was married to Geruthra, or Gertrude, daughter of Ruric king of Denmark, by whom he had a son called *Amlettus*, or *Hamlet*. Fengo murders his brother Horwendillus, marries Gertrude, and ascends the throne. Hamlet, to avoid his uncle's jealousy, counterfeits folly; and is represented as such an abhorrer of falsehood, that though he constantly frames the most evasive and even absurd answers, yet artfully contrives never to deviate from truth. Fengo, suspecting the reality of his madness, endeavours by various methods (A) to discover the real state of his mind: amongst others, he departs from Elsinour, concert a meeting between Hamlet and Gertrude, concluding that the former would not conceal his sentiments from his own mother; and orders a courtier to conceal himself, unknown to both,

(A) Among other attempts, Fengo orders his companions to leave him in a retired spot, and a young woman is placed in his way, with a view to extort from him a confession that his folly was counterfeited. Hamlet would have fallen into the snare, if a friend had not secretly conveyed to him intelligence of this treachery. He carries the woman to a more secret place, and obtains her promise not to betray him; which she readily consents to, as she had been brought up with him from her infancy. Being asked, upon his return home, if he had indulged his passion, he answers in the affirmative; but renders himself not believed by the most artful subterfuges, which, though true, seemed evidently to mark a disordered understanding, and by the positive denial of the woman. "Upon this woman," as Capell observes, "is grounded Shakespeare's Ophelia; and his deliverance from this snare by a friend suggested his Horatio;"—"the rude outlines," as Mr Malone remarks, "of those characters. But in this piece there are no traits of the character of Polonius: there is indeed a counsellor, and he places himself in the queen's chamber behind the arras; but this is the whole. The ghost of the old Hamlet is likewise the offspring of our author's creative imagination." See *Capell's School of Shakespeare*, vol. iii. p. 20.; and *Malone's Supplement*, p. 353.

Hamlet. both, for the purpose of overhearing their conversation. The courtier repairs to the queen's apartment, and hides himself under a heap of straw (B). Hamlet, upon entering the cabinet, suspecting the presence of some spy, imitates, after his usual affectation of folly, the crow of cock, and, shaking his arms like wings, jumps (C) upon the heap of straw; till, feeling the courtier, he draws his sword, and instantly dispatches him. He then cuts the body to pieces, boils it, and gives it to the hogs. He then avows to his mother that he only personated a fool, reproaches her for her incestuous marriage with the murderer of her husband; and concludes his remonstrances by saying, "Instead, therefore, of condoling my insanity, deplore your own infamy, and learn to lament the deformity of your own mind (D)." The queen is silent; but is recalled to virtue by these admonitions. Fengo returns to Elsinour, sends Hamlet to England under the care of two courtiers, and requests the king by a letter to put him to death. Hamlet discovers and alters the letter; so that, upon their arrival in England, the king orders the two courtiers to immediate execution, and betroths his daughter to Hamlet, who gives many astonishing proofs of a most transcendent understanding. At the end of the year he returns to Denmark, and alarms the court by his unexpected appearance; as a report of his death had been spread, and preparations were making for his funeral. Having re-assumed his affected insanity, he purposely wounds his finger in drawing his sword, which the bystanders immediately fasten to the scabbard. He afterwards invites the principal nobles to an entertainment, makes them intoxicated, and in that state covers them with a large curtain, which he fastens to the ground with wooden pegs; he

then sets fire to the palace; and the nobles, being enveloped in the curtain, perish in the flames. During this transaction he repairs to Fengo's apartment; and, taking the sword which lay by the side of his bed, puts his own in its place; he instantly awakens and informs him, that Hamlet is come to revenge the murder of his father. Fengo starts from his bed, seizes the sword; but being unable to draw it, falls by the hand of Hamlet. The next morning, when the populace were assembled to view the ruins of the palace, Hamlet summons the remaining nobles; and in a masterly speech, which is too long to insert in this place, lays open the motives of his own conduct, proves his uncle to have been the assassin of his father; and concludes in the following words: "Tread upon the ashes of the monster, who, polluting the wife of his murdered brother, joined incest to parricide; and ruled over you with the most oppressive tyranny. Receive me as the minister of a just revenge, as one who felt for the sufferings of his father and his people. Consider me as the person who has purged the disgrace of his country; extinguished the infamy of his mother; freed you from the despotism of a monster, whose crimes, if he had lived, would have daily increased, and terminated in your destruction. Acknowledge my services; and if I have deserved it, present me with the crown. Behold in me the author of these advantages: no degenerate person, no parricide; but the rightful successor to the throne, and the pious avenger of a father's murder. I have rescued you from slavery, restored you to liberty, and re-established your glory: I have destroyed a tyrant, and triumphed over an assassin. The recompense is in your hands: you can estimate the value of my services, and in your virtue I rest my hopes of reward." This speech

Hamlet.

(B) The reader will recollect, that straw used formerly to be spread over the floors as an article of great luxury.

(C) This part stands thus in the English account: "The counsellor entered secretly into the queene's chamber, and there hid himself behind the arras, and long before the queene and Hamlet came thither: who being craftie and politike, as soone as he was within the chamber, doubting some treason, and fearing if he should speak severely and wisely to his mother touching his secret practises hee should be understood, and by that means intercepted, used his ordinary manner of dissimulation, and began to come (r. crow) like a cocke, beating with his arms (in such manner as cockes used to strike with their wings) upon the hangings of the chambers; whereby feeling something stirring under them, he cried, *A rat! a rat!* and presently drawing his sworde, thrust it into the hangings; which done, he pulled the counsellor (half deade) out by the heels, made an end of killing him; and, being slain, cut his body in pieces, which he caused to be boiled, and then cast it into an open vault or privie." *Malone's Supplement*, vol. i. p. 357.

(D) The closet-scene, which is so beautiful in Shakespeare's Hamlet, is thus concisely, but not less finely, described by the Danish historian: "Cumque mater magno ejulatu questa presentis filii socordiam deslere cœpisset; 'Quid (inquit) mulierum turpissima gravissimi criminis dissimulationem falso lamenti genere expetis, quæ scorti more lasciviens nefariam ac detestabilem thori conditionem secuta viri tui interfectorem pleno incesti sinu amplecteris: et ei qui prolis tuæ parentem extinxerat obscœnissimis blandimentorum illecebris adularis. Ita nempe equæ conjugum suorum victoribus maritatur. Brutorum natura hæc est; ut in diversa passim conjugia rapiantur: hoc tibi exemplo prioris mariti memoriam exolevisse constat. Ego vero non ab re stolidi speciem gero, cum haud dubitem quin is qui fratrem oppresserit, in affines quoque pari crudelitate debacchaturus sit: unde stoliditatis quæ industriæ habitum amplecti præstat, et incolumitatis præsidium ab extrema deliramentorum specie mutuari. In animo tamen paternæ ultionis studium perseverat; sed rerum occasiones aucupor, temporum opportunitates opperor. Non idem omnibus locus competit. Contra obscurum immitemque animom altioribus ingenii modis uti convenit. Tibi vero supervacuum fit meam lamentari desipientiam quæ tuam justis ignominiam deplorare debueras. Itaque non aliensæ sed propriæ mentis vitium defleas necesse est. Cætera silore memineris.' Tali convitio laceratam matrem ad excolendum virtutis habitum revocavit, præteritosque ignes præsentibus illecebris præferre docuit."

Hamlet speech has the desired effect; the greater part of the assembly shed tears, and all who are present unanimously proclaim him king amid repeated acclamations.

Hamlet soon after his elevation sails to England, and orders a shield to be made on which the principal actions of his life are represented. The king receives him with feigned demonstrations of joy, falsely assures him that his daughter is dead, and recommends him to repair to Scotland as his ambassador, and to pay his addresses to the queen Hermetruda. He gives this insidious advice with the hopes that Hamlet may perish in the attempt; as the queen, who was remarkable for her obstinacy and cruelty, had such an aversion to all proposals of marriage, that not one of her suitors had escaped falling a sacrifice to her vengeance. Hamlet, in opposition to all difficulties, performs the embassy; and, by the assistance of his shield, which inspires the lady with a favourable opinion of his wisdom and courage, obtains her in marriage, and returns with her to England. Informed by the princess to whom he had been betrothed, that her father meditates his assassination, Hamlet avoids his fate by wearing armour under his robe; puts to death the king of England; and sails to Denmark with his two wives, where he is soon afterwards killed in a combat with Vigletus son of Ruric. Hamlet, adds the historian, was a prince, who, if his good fortune had been equal to his deserts, would have rivalled the gods in splendour, and in his actions would have exceeded even the labours of Hercules.

HAMMER, a well known tool used by mechanics, consisting of an iron head, fixed crosswise upon a handle of wood. There are several sorts of hammers used by blacksmiths; as, 1. The hand-hammer, which is of such weight that it may be welded or governed with one hand at the anvil. 2. The up-hand sledge, used with both hands, and seldom lifted above the head. 3. The about-sledge, which is the biggest hammer of all; and held by both hands at the farthest end of the handle; and being swung at arms length over the head, is made to fall upon the work with as heavy a blow as possible. There is also another hammer used by smiths, called a *rivetting hammer*; which is the smallest of all, and is seldom used at the forge unless upon small work.—Carpenters and joiners have likewise hammers accommodated to their several purposes.

HAMMERING, the act of beating or extending and fashioning a body under the hammer. When this operation is performed on iron heated for the purpose, it is usually called *forging*.

HAMMERING, in coining. A piece of money or a medal is said to be hammered when struck, and the impression given, with a hammer and not with a mill.

HAMMERSMITH, four miles west from London, is a hamlet belonging to Fulham, has two charity-schools, a workhouse, a Presbyterian meeting-house, and a fair May 1. There are a number of handsome seats about it, especially towards the Thames; among which the most remarkable is the late Lord Melcombe's, which is a very elegant house, and contains a marble gallery. Population 7393 in 1811.

HAMMOCK, or **HAMAC**, a kind of hanging bed, suspended between two trees, posts, hooks, or the like, much used throughout the West Indies, as also on board of ships. The Indians hang their hammocks to

trees, and thus secure themselves from wild beasts and insects, which render lying on the ground there very dangerous. According to F. Plumier, who has often made use of the hammock in the Indies, it consists of a large strong coverlet or sheet of coarse cotton, about six feet square: on two opposite sides are loops of the same stuff, through which a string is run, and thereof other loops are formed, all which are tied together with a cord; and thus is the whole fastened to two neighbouring trees in the field, or two books in houses. This kind of couch serves at the same time for bed quilts, sheets, pillow, &c.

The hammock used on board of ships is made of a piece of canvas six feet long and three feet wide, gathered or drawn together at the two ends. There are usually from fourteen to twenty inches in breadth allowed between decks for every hammock in a ship of war; but this space must in some measure depend on the number of the crew, &c. In time of battle the hammocks and bedding are firmly corded and fixed in the nettings on the quarter-deck, or wherever the men are too much exposed to the view or fire of the enemy.

HAMMOND, HENRY, D. D. one of the most learned English divines in the 17th century, was born in 1605. He studied at Oxford, and in 1629 entered into holy orders. In 1633 he was inducted into the rectory of Penshurst in Kent. In 1643 he was made archdeacon of Chichester. In the beginning of 1645 he was made one of the canons of Christ-church, Oxford, and chaplain in ordinary to King Charles I. who was then in that city; and he was also chosen public orator of the university. In 1647 he attended the king in his confinement at Woodburn, Cavesham, Hampton-Court, and the isle of Wight, where he continued till his majesty's attendants were again put from him. He then returned to Oxford, where he was chosen sub-dean; and continued there till the parliament-visitors first ejected him, and then imprisoned him for several weeks in a private house in Oxford. During this confinement he began his Annotations on the New Testament. At the opening of the year 1660, when every thing visibly tended to the restoration of the royal family, the doctor was desired by the bishops to repair to London to assist there in the composure of the breaches of the church, his station in which was designed to be the bishopric of Worcester; but on the 4th of April he was seized by a fit of the stone, of which he died on the 25th of that month, aged 55. Besides the above work, he wrote, many others; all of which have been published together in four volumes folio.

HAMMOND, Anthony, Esq. an ingenious English poet, descended from a good family of Somersham Place in Huntingdonshire, was born in 1668. After a liberal education at St John's college, Cambridge, he was chosen member of parliament, and soon distinguished himself as a fine speaker. He became a commissioner of the royal navy, which place he quitted in 1712. He published A Miscellany of original Poems by the most eminent hands; in which himself, as appears by the poems marked with his own name, had no inconsiderable share. He wrote the life of Walter Moyle, Esq. prefixed to his works. He was the intimate friend of that gentleman, and died about the year 1726.

HAMMOND, James, known to the world by the *Love-Elegies*,

Hampshire. Elegies, which some years after his death, were published by the earl of Chesterfield, was the son of Anthony Hammond above mentioned, and was preferred to a place about the person of the late prince of Wales, which he held till an unfortunate accident deprived him of his senses. The cause of this calamity was a passion he entertained for a lady, who would not return it: upon which he wrote those love-elegies which have been so much celebrated for their tenderness. The editor observes, that he composed them before he was 21 years of age: a period, says he, when fancy and imagination commonly riot at the expence of judgment and correctness. He was sincere in his love as in his friendship; and wrote to his mistress, as he spoke to his friends, nothing but the genuine sentiments of his heart. Tibullus seems to have been the model our author judiciously preferred to Ovid; the former writing directly from the heart to the heart, the latter too often yielding and addressing himself to the imagination. Mr Hammond died in the year 1743, at Stow, the seat of Lord Cobham, who, as well as the earl of Chesterfield, honoured him with a particular intimacy.

HAMPSHIRE, or **HANTS**, a county of England, bounded on the west by Dorsetshire and Wiltshire, on the north by Berkshire, on the east by Surrey and Sussex, and on the south by the English channel. It extends 55 miles in length from north to south, and 40 in breadth from east to west, and is about 220 miles in circumference. It is divided into 39 hundreds; and contains 9 forests, 29 parks one city, 20 market-towns, 253 parishes. In 1811 the number of houses was 44,240, and of inhabitants 245,080, who elect 26 members of parliament, two for the county, two for the city of Winchester, and two for each of the following towns, Southampton, Portsmouth, Petersfield, Yarmouth, Newport, Stockbridge, Andover, Whitechurch, Lympington, Christ-church, and Newton.—The air is very pure and pleasant, especially upon the downs, which are covered with sheep to the amount, it is said, of 350,000. In the champaign part of the county, where it is free of wood, the soil is very fertile, producing all kinds of grain. The country is extremely well wooded and watered; for besides many woods on private estates, in which there are vast quantities of well grown timber, there is the New forest of great extent, belonging to the crown, well stored with venerable oak. In these woods and forests, great numbers of hogs run at large and feed on the acorns; and hence it is that the Hampshire bacon so far excels that of most other counties. The rivers are the Avon, Anton, Arle, Test, Stowre, and Itchin; besides several smaller streams, all abounding in fish, especially trout. As its sea-coast is of a considerable extent, it possesses many good ports and harbours, and is well supplied with salt-water fish. Much honey is produced in the county, and a great deal of mead and metheglin made. Here is also plenty of game, and on the downs is most delightful hunting. The manufacture of cloth and kersies in this county, though not so extensive as that of some others, is yet far from being inconsiderable, and employs great numbers of the poor, as well as contributes to the enriching of the manufacturers by what is sent abroad. The canal in this county, from Basingstoke to the Wey in Surrey, and from thence to the Thames, cannot but be a great advantage to the county in general, and the

parishes it passes through in particular; to carry this Hampshire canal into execution above 86,000l. were raised amongst 150 proprietors in 1789. It extends 53 miles, and was completed in 1796. See **HAMPSHIRE**, SUPPLEMENT.

New HAMPSHIRE, one of the states of the North American republic. It is bounded on the north by Lower Canada, on the west by Vermont, on the south by Massachusetts, and on the east by Maine, except at one corner where it is washed by the Atlantic ocean for a space of eighteen miles. Its length from north to south is 168 miles, its greatest breadth 90, and its area is 9491 square miles. Near the sea the country is generally pretty level, but at some distance from the shore it becomes hilly, and afterwards swells into mountains. Mount Washington, one of the White mountains in this state, has an elevation of 7000 feet, and is the highest land in the United States. The winter is long and severe, the thermometer sometimes sinking to 12° or 14° below zero. But the climate is in other respects healthy, and the inhabitants enjoy a vigorous constitution, and afford some remarkable instances of longevity.

The principal rivers are the Connecticut, which bounds the state on the west; the Merrimack, about a hundred miles long; and the Piscataqua, fifty miles long, which forms part of the eastern boundary of the state. The navigation of all these rivers is interrupted by frequent falls.

Bog iron ore, and black lead, are the only metals worked in the state. The former affords iron of an excellent quality. Freestone, soapstone, and mica, are found at particular places. The variety of forest trees in the state is great, and many of them furnish excellent wood. The mast pine rises to the height of 150 or 200 feet, with a trunk remarkably straight.

Of animals, the black bear is the most mischievous. It makes great havock in the fields of Indian corn. The wolf is still common, and commits ravages among the sheep, though a price is set on his head. The beaver and the wild turkey have become rare.

The population of New Hampshire in 1749 was estimated at 30,000. In 1790 it was found by the census to be 141,885; in 1800, it amounted to 183,858; and in 1810 to 214,460. Even this last number gives only 22 inhabitants to each square mile. The climate, as already observed, is healthy; and the people of this state are generally distinguished by vigour, activity, and perseverance. Marriage is so general, that it is rare to find an unmarried man of thirty years of age. Many women are grandmothers at forty; and it is not uncommon to see the father, son, and grandson, working together in the same field. Dancing is a favourite amusement, and is indulged in on all occasions, which brings numbers together.

The leading occupation in this state is agriculture. The banks of the rivers, and the vallies, produce fine crops of wheat, maize, and rye, with hemp, flax, and culinary plants. Good lands yield from thirty to forty bushels of Indian corn per acre. Every agriculturist has an orchard, which supplies him with fruit in abundance. A great proportion of the land is in pasture, and the produce of the dairy is reckoned excellent. The black cattle are numerous and good, but the breed of horses is not much esteemed. In 1799 the appro-

Hampshire. printed lands in this state were valued at 19,028,108 dollars, and the houses at 4,146,938, making together 23,175,046 dollars. In 1814, their value was found to be 36,957,825, being an increase of more than one half in 15 years. The manufactures and commerce of this state are trifling. Its exports by sea in 1817 amounted to 197,424 dollars. Its only port is Portsmouth, which possessed shipping to the amount of 29,745 tons in 1815.

The legislative power resides in a senate and house of representatives, each of which has a negative on the other. The senators, 13 in number, are elected annually by citizens paying taxes, every person, 21 years of age, not a pauper, having a vote. The representatives are elected in the same manner: their number is variable, as it depends on the number of rateable polls. The governor is chosen annually by the same electors. The judiciary is composed of a superior court, with four judges, who make two circuits annually through the counties; of an inferior court in each county, with the same number of judges, who sit four months a-year; of a court of general sessions; and of a justice of peace court. The judges are appointed by the governor and council, and remain in office to the age of 70, subject to impeachment on the address of the legislature. The salary of the chief justice is 1500 dollars, and that of the associate judges 1200 dollars. As all political institutions are liable to corruption, it is provided, that the constitution of this state shall, every seven years, be submitted to the revision of the whole qualified voters, that it may be purged of any abuses which have crept in, and brought back to its first principles. Complete liberty is established in matters of religion. No separate sect is decorated with the title of a national church, and endowed with privileges which enable it to tyrannize over the others. The prevailing religious denominations are, the Presbyterians, Episcopalians, Baptists, Quakers, Congregationalists, and Universalists. Slavery is not prohibited by any law, but there are almost no slaves in the state.

In the township of Hanover, in the western part of this state, is Dartmouth College, situated on a beautiful plain, about half a mile east of Connecticut river, in latitude $43^{\circ} 33'$. It was named after the right honourable William earl of Dartmouth, who was one of its principal benefactors. It was founded in 1769, for the education and instruction of youth, of the Indian tribes, in reading, writing, and all parts of learning which should appear necessary and expedient for civilizing and christianizing the children of Pagans, as well as in all liberal arts and sciences, and also of English youths and any others. Its situation, in a frontier country, exposed it during the late war to many inconveniences, which prevented its rapid progress. It flourished, however, amidst all its embarrassments, and is now one of the most growing seminaries in the United States. It has about 150 students, under the direction of a president, two professors, and two tutors, and its annual revenue is about 2000 dollars a-year, exclusive of class fees. It has 12 trustees, who are a body corporate, invested with the powers necessary for such a body. The library is elegant, containing a large collection of the most valuable books. Its apparatus consists of a competent number of useful instruments, for

making mathematical and philosophical experiments. Hampshire There are three buildings for the use of the students. Such is the salubrity of the air, that no instance of mortality has happened among the students since the first establishment of the college. Hampshire Hampton.

The first discovery made by the English of any part of New Hampshire was in 1614, by Captain John Smith, who ranged the shore from Penobscot to Cape Cod; and in this route discovered the river Piscataqua. On his return to England, he published a description of the country, with a map of the coast, which he presented to Prince Charles, who gave it the name of *New England*. The first settlement was made in 1623.

New Hampshire was for many years under the jurisdiction of the governor of Massachusetts, yet they had a separate legislature. They ever bore a proportionable share of the expences and levies in all enterprises, expeditions, and military exertions, whether planned by the colony or the crown. In every stage of the opposition that was made to the encroachments of the British parliament, the people, who ever had a high sense of liberty, cheerfully bore their part.

HAMPSTEAD, a pleasant village of Middlesex, five miles north-west of London, stands in a healthy air, on a fine rise, at the top of which is a heath of about a mile every way, that is adorned with several pretty seats, in a most irregular romantic situation, and has a most extensive prospect over London, into the counties all round it, viz. Bucks and Hertfordshire, and even Northamptonshire, Essex, Kent, Surrey, Berks, &c. with an uninterrupted view of Shooter's Hill, Bansted Downs, and Windsor Castle. Its church was anciently a chapel of ease to Hendon, till about 1478. This village used to be resorted to formerly for its mineral waters, which have lately been neglected: but the wells are still frequented. It is now crowded with good buildings, even on the very steep of the hill, where there is no walking six yards together without meeting a hillock; but in the reign of Henry VIII. it was chiefly inhabited by the laundresses who washed for the Londoners. Its old ruinous church, the lord of the manor's chapel, was pulled down many years ago, and a new one erected in its room. There is, besides, a handsome chapel near the wells, built by the contribution of the inhabitants, who are chiefly citizens and merchants of London. Population 5483 in 1811.

HAMPTON, a town of Gloucestershire in England, seated on the Cotswold hills, and had formerly a nunnery. W. Long. 2. 15. N. Lat. 51. 38.

HAMPTON, a town of Middlesex in England, seated on the river Thames, 15 miles west of London, and two from Richmond and Kingston. It is chiefly famous for the royal palace there, which is the finest in Britain. It was built by Cardinal Wolsey, who had 280 silk beds for strangers only, and furnished it richly with gold and silver plate. The buildings, gardens, and the two parks, to which William III. made considerable additions, are about four miles in circumference, and are watered on three sides by the Thames. The inward court, built by King William, forms a piazza, the pillars of which are so low, that it looks more like a cloister than a palace; however, the apartments

Hampton
Hannu.

ments make ample amends, being extremely magnificent, and more exactly disposed than in any other palace in the world, and adorned with most elegant furniture. Since the accession of his present majesty, however, this palace hath been much neglected, as the king has generally made choice of Windsor for his summer retreat. Those inimitable paintings of Raphael Urbin, called the *cartoons*, which were placed there by King William, have been removed to the queen's palace at Westminster. For these pieces Louis XV. is said to have offered 100,000*l*.

HAMESOKEN, or HAMESECKEN. See **HAMESECKEN.**

HANAPER, or HAMPER, an office in chancery, under the direction of a master, his deputy and clerks, answering, in some measure, to the *fiscus* among the Romans.

HANAPER, clerk of the, sometimes styled *warden of the hanaper*, an officer who receives all money due to the king for seals of charters, patents, commissions, and writs, and attends the keeper of the seal daily in term time, and at all times of sealing, and takes into his custody all sealed charters, patents, and the like, which he receives into bags, but anciently, it is supposed, into hampers, which gave denomination to the office.

There is also an officer who is comptroller of the hanaper.

HANAU, a town of Germany, and capital of a county of the same name, is pleasantly situated on the river Kenzig near its confluence with the Mayne. The river divides it into the old and new towns, both of which are fortified. The new town, which was built at first by French and Flemish refugees, who had great privileges granted them, is regular and handsome. The castle, in which the counts used to reside, and which stands in the old town, is fortified, and has a fine flower-garden with commodious apartments, but makes no great appearance. The magistracy of the new town, and the disposal of all offices in it, belong to the French and Dutch congregations. Here is an university, with several manufactures. At this town a sanguinary battle was fought between the French and Bavarians in 1813, in which the latter were defeated. E. Long. 9. o. N. Lat. 50. 9.

HANAU-Munzenberg, a county of Germany. The greatest part of it is surrounded by the electorate of Mentz, the bishopric of Fulda, the lordships of Reineck, Isenburg, and Solms; as also by the territories of Hesse-Homburg, Burg-Friedburg, and Frankfort. Its length is near 40 miles, but its greatest breadth, not above 12. It is exceeding fertile in corn, wine, and fruits; has some salt springs, and some mines of copper, silver, and cobalt. The chief rivers are, the Mayne, the Kenzig, and the Nidda. The prevailing religion is Calvinism, but Lutherans and Catholics are tolerated. The country is populous, and trade and manufactures flourish in it. In 1736, the whole male line of the counts of Hanau failing in John Reinard, William VIII. landgrave of Hesse Cassel, by virtue of a treaty of mutual succession between the families of Hanau and Hesse Cassel, took possession of the county, satisfaction having been first made to the house of Saxony for their claims; and in the year 1754, transferred it to Prince William, eldest son to the hereditary prince Frederic, afterwards landgrave. The re-

venues of the last count, arising from this and other territories, are said to have amounted to 500,000 florins. The principal places are Hanau, Bergen, Steinau, and Glenhausen.

HANCES, HANCHES, HAUNCHES, or HANSES, in *Architecture*, certain small intermediate parts of arches between the crown and the spring at the bottom, being probably about one-third of the arch, and placed nearer to the bottom than the top, which are likewise denominated the *spandrels*.

HAND, a part or member of the body of man, making the extremity of the arm. See **ANATOMY, N° 53, &c.**

The mechanism of the hand is very curious; excellently contrived to fit it for the various uses and occasions we have for it, and the great number of arts and manufactures it is to be employed in. It consists of a compages of nerves, and little bones joined into each other, which give it a great degree of strength, and at the same time an unusual flexibility, to enable it to handle adjacent bodies, lay hold of them, and grasp them, in order either to draw them toward us or thrust them off. Anaxagoras is represented by ancient authors, as maintaining, that man owes all his wisdom, knowledge, and superiority over other animals, to the use of his hands. Galen represents the matter otherwise; man, according to him, is not the wisest creature because he has hands; but he had hands given him because he was the wisest creature: for it was not our hands that taught us arts, but our reason. The hands are the organs of-reason, &c.

In scripture, the word *hand* was variously applied. To pour water on any one's hand, signifies to serve him. To wash the hands was a ceremony made use of to denote innocency from murder or manslaughter. To kiss the hand was an act of adoration. To fill the hand signified taking possession of the priesthood, and performing its functions. To lean upon any one's hand was a mark of familiarity and superiority. To give the hand signifies to grant peace, swear friendship, promise security, or make alliance. The right hand was the place of honour and respect.—Amongst the Greeks and Romans it was customary for inferiors to walk on the left hand of superiors, that their right hand might be ready to afford protection and defence to their left side, which was, on account of the awkwardness of the left hand, more exposed to danger.

Imposition, or laying on of HANDS, signifies the conferring of holy orders; a ceremony wherein the hands are laid on the head of another, as a sign of a mission, or of a power given him to exercise the functions of the ministry belonging to the order.

The apostles began to appoint missionaries by the imposition of hands. See **IMPOSITION.**

HAND, in falconry, is used for the foot of the hawk. To have a clean, strong, slender, glutinous hand, well clawed, are some of the good qualities of a hawk or falcon.

HAND, in the manege, sometimes stands for the fore-foot of a horse. It is also used for a division of the horse into two parts with respect to the rider's hand. The fore-hand includes the head, neck, and fore-quarters; the hind-hand is all the rest of the horse.

HAND is likewise used for a measure of four inches,

Hannu
Hard.

Hand,
Handel.

or of a clenched fist, by which the height of a horse is computed.

HAND is also figuratively used in painting, sculpture, &c. for the manner or style of this or that master.

HANDS are borne in coat-armour, *dexter* and *sinister*; that is, right and left, expanded or open; and after other manners. A bloody hand in the centre of the escutcheon is the badge of a baronet of Great Britain.

HAND-Breadth, a measure of three inches.

HANDEL, GEORGE FREDERIC, a most eminent master and composer of music, was born at Hall, a city of Upper Saxony in Germany. His father was a physician and surgeon of that place, and was upwards of 60 years of age when Handel was born. During his infancy young Handel is said to have amused himself with musical instruments, and to have made considerably progress before he was seven years of age, without any instructions. His propensity for music at last became so strong, that his father, who designed him for the study of the civil law, thought proper to forbid him, even at this early period of life, to touch a musical instrument, and would suffer none to remain in his house. Notwithstanding this prohibition, however, Handel found means to get a little clavichord privately conveyed to a room in the uppermost story of the house, to which room he constantly stole when the family were asleep; and thus made such advances in his art, as enabled him to play on the harpsichord. He was first taken notice of by the duke of Saxe Weissenfels on the following occasion. His father went to pay a visit to another son by a former wife, who was valet de chambre to the duke, and resided at his court. Young Handel, being then in his seventh year, earnestly desired permission to go along with him; but being refused, he followed the chaise on foot, and overtook it, the carriage being probably retarded by the roughness of the way. His father at first chid him for his disobedience, but at last took him into the chaise along with him. While he was in the duke's court, he still continued to show the same inclination for music; it was impossible to keep him from harpsichords; and he used sometimes to get into the organ-loft at church, and play after service was over. On one of these occasions, the duke happening to go out later than usual, found something so uncommon in Handel's manner of playing, that he inquired of his valet who it was; and receiving for answer that it was his brother, he desired to see him. This nobleman was so much taken with the musical genius shown by young Handel, that he persuaded his father to let him follow the bent of his inclination. He made the boy a present; and told him, that if he minded his studies, no encouragement should be wanting.

On his return to Hall, Handel was placed under one Zackaw, the organist of the cathedral church; and our young musician was even then able to supply his master's place in his absence. At nine years of age he began to compose church-services for voices and instruments, and continued to compose one such service every week for three years successively. At the age of 14, he far excelled his master, as he himself owned; and he was sent to Berlin, where he had a relation in some place about the court, on whose care and fidelity his parents could rely. The opera was then in a flourish-

Handel.

ing condition, being encouraged by the grandfather of the late king of Prussia, and under the direction of many eminent persons from Italy, among whom were Buononcini and Attilio. Buononcini, being of a haughty disposition, treated Handel with contempt; but Attilio behaved to him with great kindness, and he profited much by his instructions. His abilities soon recommended him to the king, who frequently made him presents, and at last proposed to send him to Italy under his own patronage, and to take him under his immediate protection as soon as his studies should be completed. But Handel's parents not thinking proper to submit their child to the caprice of the king, declined the offer; upon which it became necessary for him to return to Hall.

Handel having now obtained ideas in music far excelling every thing that could be found in Hall, continued there very unwillingly, and it was resolved to send him to Italy: but as the expence of this journey could not then be spared, he went to Hamburg, where the opera was little inferior to that of Berlin. Soon after his arrival in this city, his father died; and his mother being left in narrow circumstances, her son thought it necessary to procure some scholars, and to accept a place in the orchestra; by which means, instead of being a burden, he became a great relief to her.

At this time, the first harpsichord in Hamburg was played by one Keser, a man who also excelled in composition; but he, having involved himself in some debts, was obliged to abscond. Upon this vacancy, the person who had been used to play the second harpsichord claimed the first by right of succession; but was opposed by Handel, who founded a claim to the first harpsichord upon his superior abilities. After much dispute, in which all who supported or directed the opera engaged with much vehemence, it was decided in favour of Handel; but this good success had almost cost him his life. His antagonist resented the supposed affront so much, that, as they were coming out of the orchestra together, he made a push at Handel's breast with a sword, which must undoubtedly have killed him, had there not fortunately been a music-book in the bosom of his coat.

Handel, though yet but in his 15th year, became composer to the house; and the success of *Almeria*, his first opera, was so great, that it ran 30 nights without interruption. Within less than a twelvemonth after this, he set two others called *Florinda* and *Norene*, which were received with the same applause. During his stay here, which was about four or five years, he also composed a considerable number of sonatas, which are now lost. Here his abilities procured him the acquaintance of many persons of note, particularly the prince of Tuscany, brother to John Gaston de Medicis the grand duke. This prince pressed him to go with him to Italy, where he assured him that no convenience would be wanting; but this offer Handel thought proper to decline, being resolved not to give up his independency for any advantage that could be offered him.

In the 19th year of his age, Handel took a journey to Italy on his own account; where he was received with the greatest kindness by the prince of Tuscany, and had at all times access to the palace of the grand duke.

Handel. duke. His Serene Highness was impatient to have something composed by so great a master; and notwithstanding the difference between the style of the Italian music and the German, to which Handel had hitherto been accustomed, he set an opera called *Rodrigo*, which pleased so well that he was rewarded with 100 sequins and a service of plate. After staying about a year in Florence, he went to Venice, where he is said to have been first discovered at a masquerade. He was playing on a harpsichord in his visor, when Scarlatti, a famous performer, cried out, that the person who played could be none but the famous Saxon or the devil. But a story similar to this is reported of many eminent persons whose abilities have been discovered in disguise. Here he composed his opera called *Agrippina*, which was performed 27 nights successively, with the most extravagant applause.

From Venice our musician proceeded to Rome, where he became acquainted with Cardinal Ottoboni and many other dignitaries of the church, by which means he was frequently attacked on account of his religion; but Handel declared he would live and die in the religion in which he had been educated, whether it was true or false. Here he composed an oratorio called *Resurrectione*, and 150 cantatas, besides some sonatas, and other music. Ottoboni also contrived to have a trial of skill between him and Dominici Scarlatti, who was considered as the greatest master on that instrument in Italy. The event is differently reported. Some say that Scarlatti was victorious, and others give the victory to Handel; but when they came to the organ, Scarlatti himself ascribed the superiority to Handel.

From Rome, Handel went to Naples; after which, he paid a second visit to Florence; and at last, having spent six years in Italy, set out for his native country. In his way thither, he was introduced at the court of Hanover with so much advantage by the baron Kilmanseck, that his Electoral Highness (afterwards George I.) offered him a pension of 1500 crowns a-year as an inducement to continue there. This generous offer he declined on account of his having promised to visit the court of the Elector Palatine, and likewise to come over to England in compliance with the repeated invitations of the duke of Manchester. The elector, however, being made acquainted with this objection, generously ordered him to be told, that his acceptance of the pension should neither restrain him from his promise nor resolution: but that he should be at full liberty to be absent a year or more if he chose it, and to go wherever he thought fit. Soon after, the place of master of the chapel was bestowed upon Handel; and our musician having visited his mother, who was now extremely aged and blind, and his old master Zackaw, and staid some time at the court of the Elector Palatine, set out for England, where he arrived in 1710.

At that time operas were a new entertainment in England, and were conducted in a very absurd manner: but Handel soon put them on a better footing; and set a drama called *Rinaldo*, which was performed with uncommon success. Having staid a year in England, he returned to Hanover; but in 1712 he again came over to England; and the peace of Utrecht being concluded a few months afterwards, he composed a grand *Te Deum* and *Jubilate* on the occasion. He now

found the nobility very desirous that he should resume the direction of the opera-house in the Hay-market; and the queen having added her authority to their solicitations, and conferred on him a pension of 200l. a-year, he forgot his engagements to the elector of Hanover, and remained in Britain till the death of the queen in 1714. On the arrival of King George I. Handel, conscious of his ill behaviour, durst not appear at court; but he was extricated from his dilemma by the baron Kilmanseck. Having engaged several of the English nobility in his behalf, the baron persuaded the king to a party of pleasure on the water. Handel was apprised of the design, and ordered to prepare some music for the occasion. This he executed with the utmost attention, and on the day appointed it was performed and conducted by himself. The king with pleasure and surprise inquired whose it was, and how the entertainment came to be provided without his knowledge. The baron then produced the delinquent; and asked leave to present him to his majesty as one too sensible of his fault to attempt an excuse, but sincerely desirous to atone for it. This intercession was accepted. Handel was restored to favour, his water music was honoured with the highest approbation, and the king added a pension of 200l. a-year to that formerly bestowed on him by Queen Anne; which he soon after increased to 400l. on his being appointed to teach the young princesses music.

In the year 1715, Handel composed his opera of *Amadige*; but from that time to the year 1720 he composed only *Tesco* and *Pastor Fido*, Buononcini and Attilio being then composers for the operas. About this time a project was formed by the nobility for erecting a kind of academy at the Hay Market, with a view to secure to themselves a constant supply of operas to be composed by Handel, and performed under his direction. No less than 50,000l. was subscribed for this scheme, of which the king himself subscribed 10000l. and it was proposed to continue the undertaking for 14 years. Handel went over to Dresden, in order to engage singers, and returned with Senesino and Duristanti. Buononcini and Attilio had still a strong party in their favour, but not equal to that of Handel; and therefore in 1720 he obtained leave to perform his opera of *Radamisto*. The house was so crowded, that many fainted through excessive heat; and 40s. were offered by some for a seat in the gallery, after having in vain attempted to get one elsewhere. The contention; however, still ran very high between Handel's party and that of the two Italian masters; and at last it was determined that the rivals should be jointly employed in making an opera, in which each should take a distinct act, and he who by the general suffrage was allowed to have given the best proof of his abilities should be put in possession of the house. This opera was called *Musio Scævola*, and Handel set the last act. It is said that Handel's superiority was owned even in the overture before it; but when the act came to be performed, there remained no pretence of doubt or dispute. The academy was now therefore firmly established, and Handel conducted it for nine years with great success; but about that time an irreconcilable enmity took place between Handel himself and Senesino. Senesino accused Handel of tyranny, and Handel accused Senesino of rebellion. The merits of the quarrel are not known:

Handel.

Handel. known: the nobility, however, became mediators for some time; and having failed in that good design, they became parties in the quarrel. Handel was resolved to dismiss Senesino, and the nobility seemed also resolved not to permit him to do so. The haughtiness of Handel's temper would not allow him to yield, and the affair ended in the total dissolution of the academy.

Handel now found that his abilities, great as they were, could not support him against the powerful opposition he met with. After the dismissal of Senesino, his audience sensibly dwindled away, and Handel entered into an agreement with Mr Heidegger to carry on operas in conjunction with him. New singers were engaged from Italy; but the offended nobility raised a subscription against him, to carry on operas in the playhouse in Lincoln's-Inn fields. Handel bore up four years against this opposition; three in partnership with Heidegger, and one by himself: but though his musical abilities were superior to those of his antagonists, the astonishing powers of the voice of Farinelli, whom the opposite party had engaged, determined the victory against him. At last Handel, having spent all he was worth in a fruitless opposition, thought proper to desist. His disappointment had such an effect upon him, that for some time he was disordered in his understanding, and at the same time his right arm was rendered useless by a stroke of the palsy. In this deplorable situation, it was thought necessary that he should go to the baths of Aix-la-Chapelle; and from them he received such extraordinary and sudden relief, that his cure was looked upon by the nuns as miraculous.

In 1736, Handel again returned to England; and soon after his return his Alexander's Feast was performed with applause at Covent Garden. The success and splendour of the Hay Market was by this time so much reduced by repeated mismanagements, that Lord Middlesex undertook the direction of it himself, and once more applied to Handel for composition. He accordingly composed two operas called *Faramondo*, and *Alessandro Severo*, for which in 1737 he received 1000l. In 1738, he received 1500l. from a single benefit, and nothing seemed wanting to retrieve his affairs, excepting such concessions on his part as his opponents had a right to expect. These concessions, however, he could not be prevailed upon to make; and that he might no longer be under obligations to act as he was directed by others, he refused to enter into any engagements upon subscription. After having tried a few more operas at Covent Garden without success, he introduced another species of music called *oratorios*, which he thought better suited to the native gravity of an English audience. But as the subjects of these pieces were always taken from sacred history, it was by some thought to be a profanation to set them to music and perform them at a playhouse. In consequence of this prejudice, the oratorios met with very indifferent success; and in 1741 Mr Handel found his affairs in such a bad situation, that he was obliged to quit England, and go to Dublin.

He was received in Ireland in a manner suitable to his great merit; and his performing his oratorio called the *Messiah*, for the benefit of the city prison, brought him into universal favour. In nine months time he had

brought his affairs into a better situation; and on his return to England in 1742, he found the public much more favourably disposed. His oratorios were now performed with great applause: his *Messiah*, which before had been but coldly received, became a favourite performance; and Handel, with a generous humanity, determined to perform it annually for the benefit of the founding hospital, which at that time was only supported by private benefactions. In 1743, he had a return of his paralytic disorder; and in 1751 became quite blind by a *gutta serena* in his eyes. This last misfortune for some time sunk him into the deepest despondency; but at last he was obliged to acquiesce in his situation, after having without any relief undergone some very painful operations. Finding it now impossible to manage his oratorios alone, he was assisted by Mr Smith, who at his request frequently played for him, and conducted them in his stead; and with this assistance they were continued till within eight days of his death. During the latter part of his life, his mind was often disordered; yet at times it appears to have resumed its full vigour, and he composed several songs, choruses, &c. which from their dates may be considered almost as the last sounds of his dying voice. From about October 1758 his health declined very fast; his appetite, which had been remarkably keen, and which he had gratified to a great degree, left him; and he became sensible of the approach of death. On the 6th of April 1759, his last oratorio was performed, at which he was present, and died on the 14th of the same month. On the 20th he was buried by the right reverend Dr Pearce, bishop of Rochester, in Westminster abbey; where, by his own order, and at his own expence, a monument was erected to his memory.

With regard to the character of this most eminent musician, he is universally allowed to have been a great epicure: In his temper he was very haughty, but was seldom or never guilty of mean actions. His pride was uniform: he was not by turns a tyrant and a slave. He appears to have had a most extravagant love for liberty and independence; insomuch, that he would, for the sake of liberty, do things otherwise the most prejudicial to his own interest. He was liberal even when poor, and remembered his former friends when he was rich. His musical powers can perhaps be best expressed by Arbuthnot's reply to Pope, who seriously asked his opinion of him as a musician; "Conceive (said he) the highest you can of his abilities, and they are much beyond any thing you can conceive."

Commemoration of HANDEL; a musical exhibition instituted some years ago, and the grandest of the kind ever attempted in any nation. Of the rise and progress of the design, together with the manner in which the first celebration was executed, an accurate and authentic detail is given, as might be expected, by Dr Burney in the 4th and last volume of his *History of Music*, from which the following account is extracted.

"In a conversation between Lord Viscount Fitzwilliam, Sir Watkin Williams Wynn, and Joah Bates, Esq. commissioner of the victualling-office, the beginning of last year, 1783, at the house of the latter; after remarking that the number of eminent musical performers of all kinds, both vocal and instrumental,

with

Handel. with which London abounded, was far greater than in any other city of Europe, it was lamented that there was no public periodical occasion for collecting and consolidating them into one band; by which means a performance might be exhibited on so grand and magnificent a scale as no other part of the world could equal. The birth and death of Handel naturally occurred to three such enthusiastic admirers of that great master; and it was immediately recollected, that the next year (1784) would be a proper time for the introduction of such a custom, as it formed a complete century since his birth, and an exact quarter of a century since his decease.

"The plan was soon after communicated to the governors of the Musical Fund, who approved it, and promised their assistance. It was next submitted to the directors of the concert of Ancient Music; who, with an alacrity which does honour to their zeal for the memory of the great artist Handel, voluntarily undertook the trouble of managing and directing the celebrity. At length, the design coming to the knowledge of the king, it was honoured with his majesty's sanction and patronage. Westminster Abbey, where the bones of the great musician were deposited, was thought the properest place for the performance; and application having been made to the bishop of Rochester for the use of it, his lordship finding that the scheme was honoured with the patronage of his majesty, readily consented; only requesting, as the performance would interfere with the annual benefit for the Westminster Infirmary, that part of the profits might be appropriated to that charity, as an indemnification for the loss it would sustain. To this the projectors of the plan acceded; and it was afterwards settled, that the profits of the first day's performance should be equally divided between the Musical Fund and the Westminster Infirmary; and those of the subsequent days be solely applied to the use of that fund which Handel himself so long helped to sustain, and to which he not only bequeathed a thousand pounds, but which almost every musician in the capital annually contributes his money, his performance, or both, to support. Application was next made to Mr James Wyatt, the architect, to furnish plans for the necessary decorations of the abbey; drawings of which having been shown to his majesty, were approved. The general idea was to produce the effect of a royal musical chapel, with the orchestra terminating one end, and the accommodation for the royal family, the other. The arrangement of the performance of each day was next settled; and it was at his majesty's instigation that the celebrity was extended to three days instead of two, which he thought would not be sufficient for the display of Handel's powers, or fulfilling the charitable purposes to which it was intended to devote the profits. It was originally intended to have celebrated this festival on the 20th, 22d, and 23d of April; and the 20th being the day of the funeral of Handel, part of the music was, in some measure, so selected as to apply to that incident. But, in consequence of the sudden dissolution of parliament, it was thought proper to defer the festival to the 26th, 27th, and 29th of May, which seems to have been for its advantage; as many persons of tender constitutions,

who ventured to go to Westminster Abbey in warm weather, would not have had the courage to go thither in cold. Impressed with a reverence for the memory of Handel, no sooner was the project known, but most of the practical musicians in the kingdom eagerly manifested their zeal for the enterprise; and many of the most eminent professors, waving all claims to precedence in the band, offered to perform in any subordinate station in which their talents could be most useful.

"In order to render the band as powerful and complete as possible, it was determined to employ every species of instrument that was capable of producing grand effects in a great orchestra and spacious building. Among these the sacbut, or double trumpet, was sought; but so many years had elapsed since it had been used in this kingdom, that neither the instrument, nor a performer upon it, could easily be found. It was, however, discovered, after much useless inquiry, not only here, but by letter, on the continent, that in his majesty's military band there were six musicians who played the three several species of sacbut, tenor, base, and double base.

"The double bassoon, which was so conspicuous in the orchestra, and powerful in its effect, is likewise a tube of 16 feet. It was made, with the approbation of Mr Handel, by Stainsby the flute-maker, for the coronation of his late majesty George II. The late ingenious Mr Lampe, author of the justly admired music of *The Dragon of Wantley*, was the person intended to perform on it; but, for want of a proper reed, or for some other cause, at present unknown, no use was made of it at the time; nor indeed, though it has been often attempted, was it ever introduced into any band in England, till now, by the ingenuity and perseverance of Mr Ashly of the Guards.

"The double-base kettle-drums were made from models of Mr Ashbridge, of Drury Lane orchestra, in copper, it being impossible to procure plates of brass large enough. The Tower drums, which, by permission of his grace the duke of Richmond, were brought to the abbey on this occasion, are those which belong to the ordnance stores, and were taken by the duke of Marlborough at the battle of Malplaquet in 1709. These are hemispherical, or a circle divided; but those of Mr Ashbridge are more cylindrical, being much longer, as well as more capacious, than the common kettle-drum; by which he accounts for the superiority of their tone to that of all other drums. These three species of kettle-drums, which may be called *tenor*, *base*, and *double base*, were an octave below each other.

"The excellent organ, erected at the west end of the abbey for the commemoration performances only, is the workmanship of the ingenious Mr Samuel Green in Islington. It was fabricated for the cathedral of Canterbury; but before its departure for the place of its destination, it was permitted to be opened in the capital on this memorable occasion. The keys of communication with the harpsichord, at which Mr Bates the conductor was seated, extended 19 feet from the body of the organ, and 20 feet 7 inches below the perpendicular of the set of keys by which it is usually played. Similar keys were first contrived in this country for Handel himself at his oratorios; but to convey them

Handel.

Handel. them to so great a distance from the instrument, without rendering the touch impracticably heavy, required uncommon ingenuity and mechanical resources.

“ In celebrating the disposition, discipline, and effects of this most numerous and excellent band, the merit of the admirable architect, who furnished the elegant designs for the orchestra and galleries, must not be forgotten; as, when filled, they constituted one of the grandest and most magnificent spectacles which imagination can delineate. All the preparations for receiving their majesties, and the first personages in the kingdom, at the east end; upwards of 500 musicians at the west; and the public in general, to the number of between 3000 and 4000 persons, in the area and galleries; so wonderfully corresponded with the style of architecture of this venerable and beautiful structure, that there was nothing visible either for use or ornament, which did not harmonize with the principal tone of the building, and which may not metaphorically have been said to have been in perfect tune with it. But, besides the wonderful manner in which this construction exhibited the band to the spectators, the orchestra was so judiciously contrived, that almost every performer, both vocal and instrumental, was in full view of the conductor and leader; which accounts, in some measure, for the uncommon ease with which the performers confess they executed their parts.

“ At the east end of the aisle, just before the back of the choir-organ, some of the pipes of which were visible below, a throne was erected in a beautiful Gothic style, corresponding with that of the abbey, and a centre box, richly decorated and furnished with crimson satin, fringed with gold, for the reception of their majesties and the royal family: on the right hand of which was a box for the bishops, and on the left, one for the dean and chapter of Westminster; immediately below these two boxes were two others, one on the right for the families and friends of the directors, and the other for those of the prebendaries of Westminster. Immediately below the king's box was placed one for the directors themselves, who were all distinguished by white wands tipped with gold, and gold medals, struck on the occasion, appending from white ribbands. These their majesties likewise condescended to wear at each performance. Behind, and on each side of the throne, there were seats for their majesties suite, maids of honour, grooms of the bed-chamber, pages, &c.—The orchestra was built at the opposite extremity, ascending regularly from the height of seven feet from the floor to upwards of forty from the base of the pillars, and extending from the centre to the top of the side aisle.—The intermediate space below was filled up with level benches, and appropriated to the early subscribers. The side aisles were formed into long galleries ranging with the orchestra, and ascending so as to contain 12 rows on each side; the fronts of which projected before the pillars, and were ornamented with festoons of crimson morine.—At the top of the orchestra was placed the occasional organ, in a Gothic frame, mounting to, and mingling with, the saints and martyrs represented in the painted glass on the west window. On each side of the organ, close to the window, were placed the kettle-drums described above. The choral bands were principally placed in view of Mr Bates, on steps seemingly ascending into the clouds, in each of the

side aisles, as their termination was invisible to the audience. The principal singers were ranged in the front of the orchestra, as at oratorios, accompanied by the choirs of St Paul, the abbey, Windsor, and the chapel royal.

“ Few circumstances will perhaps more astonish veteran musicians, than to be informed, that there was but one general rehearsal for each day's performance: an indisputable proof of the high state of cultivation to which practical music is at present arrived in this country; for if good performers had not been found ready made, a dozen rehearsals would not have been sufficient to make them so. Indeed, Mr Bates, in examining the list of performers, and inquiring into their several merits, suggested the idea of what he called a *drilling rehearsal*, at Tottenham-street concert room, a week before the performance; in order to hear such volunteers, particularly chorus singers, as were but little known to himself, or of whose abilities his assistant was unable to speak with certainty. At this rehearsal, though it consisted of 120 performers, not more than two of that number were desired not to attend any more.

“ At the general rehearsal in the abbey, mentioned above, more than 500 persons found means to obtain admission, in spite of every endeavour to shut out all but the performers; for fear of interruption, and perhaps of failure in the first attempts at incorporating and consolidating such a numerous band, consisting not only of all the regulars, both native and foreign, which the capital could furnish, but of all the irregulars, that is, dilettanti, and provincial musicians of character, who could be mustered, many of whom had never heard or seen each other before. This intrusion, which was very much to the dissatisfaction of the managers and conductor, suggested the idea of turning the eagerness of the public to some profitable account for the charity, by fixing the price of admission to half a guinea for each person.

“ But, besides the profits derived from subsequent rehearsals, the consequences of the first were not without their use; for the pleasure and astonishment of the audience, at the small mistakes, and great effects of this first experiment, which many had condemned by anticipation, were soon communicated to the lovers of music throughout the town, to the great increase of subscribers and solicitors for tickets. For though the friends of the directors were early in subscribing, perhaps from personal respect, as much as expectation of a higher musical repast than usual; yet the public in general did not manifest great eagerness in securing tickets till after this rehearsal, Friday May 21. which was reported to have astonished even the performers themselves by its correctness and effects. But so interesting did the undertaking become by this favourable rumour, that from the great number of tickets it was found necessary to close the subscription.

“ Many families, as well as individuals, were attracted to the capital by this celebrity; and it was never remembered to have been so full, except at the coronation of his present majesty. Many of the performers came, unsolicited, from the remotest parts of the kingdom at their own expence: some of them, however, were afterwards reimbursed, and had a small gratuity in consideration of the time they were kept from

Handel.

Handel from their families by the two unexpected additional performances.

“ Foreigners, particularly the French, must be much astonished at so numerous a band moving in such exact measure, without the assistance of a coryphæus to beat the time, either with a roll of paper, or a noisy baton or truncheon. Rousseau says, that ‘ the more time is beaten, the less it is kept ;’ and it is certain, that when the measure is broken, the fury of the musical general or director, increasing with the disobedience and confusion of his troops, he becomes more violent, and his strokes and gesticulations more ridiculous, in proportion to their disorder.

“ As this commemoration is not only the first instance of a band of such magnitude being assembled together, but of any band at all numerous, performing in a similar situation, without the assistance of a conductor to regulate the measure, the performances in Westminster abbey may be safely pronounced no less remarkable for the multiplicity of voices and instruments employed, than for accuracy and precision. When all the wheels of that huge machine, the orchestra, were in motion, the effect resembled clock-work in every thing but want of feeling and expression. And as the power of gravity and attraction in bodies is proportioned to their mass and density, so it seems as if the magnitude of this band had commanded and impelled adhesion and obedience beyond that of any other of inferior force. The pulsations in every limb, and ramifications of veins and arteries in an animal, could not be more reciprocal, isochronous, and under the regulation of the heart, than the members of this body of musicians under that of the conductor and leader. The totality of sound seemed to proceed from one voice and one instrument ; and its powers produced not only new and exquisite sensations in judges and lovers of the art, but were felt by those who never received pleasure from music before. These effects, which will be long remembered by the public, perhaps to the disadvantage of all other choral performances, run the risk of being doubted by all but those who heard them, and the present description of being pronounced fabulous, if it should survive the present generation.”

HANDSPIKE, or **HANDSPEC**, a wooden bar used as a lever to heave about the windlass, in order to draw up the anchor from the bottom, particularly in merchant ships. The handle is round and tapering, and the other end is square, to conform to the shape of the holes in the windlass. It is also employed as a lever on many other occasions, as stowing the anchors, provisions, or cargo, in the ship's hold. The gunner's handspike is shorter and flatter than the above, and armed with two claws for managing the artillery, &c.

HANG-TCHOO-FOO, the capital of the province of Tche-Kiang in China, is situated between the bason of the grand canal, and the river Chen-tang-chaung, which falls into the sea about 60 miles to the eastward, and in N. Lat. 30° 21'. E. Long. 120° 20'. Hang-tchoo-foo exports and receives vast quantities of merchandise to and from the southern provinces by means of this river. There is no communication by water between the river and the bason of the grand canal, in consequence of which all goods brought by sea into the river from the southward, must be landed at this city, in their way to the north. Its population is immense, being computed

VOL. X. Part I.

to be nearly as numerous as in Peking, which contains about 3,000,000 of inhabitants. The houses are low, none exceeding two stories; and the streets, the middle of which is paved with smooth flags, and the sides with small flat stones, are very narrow. The principal streets contain nothing but shops and warehouses, many of which are equally splendid with those of the kind in London. Sir George Staunton informs us, that it is extremely difficult to pass along the streets, on account of the prodigious numbers of people, all engaged in their own concerns. Several men, but no women, attend in these shops behind the counters. The women are employed in the manufacture of silk, every part of which is done by them alone. In their dress they are not regulated by fancy or fashion, but by what is conducive to health, and the season of the year. Even among the ladies, there is little variety in their dress, except in the disposition of the ornaments of the head. The fair sex esteem corpulency in a man to be a beauty, but they aim at preserving a delicacy of shape as to themselves. They allow their nails to grow, and reduce their eyebrows to an arched line.

The natural and artificial beauties of the lake of Hang-tchoo-foo, in the opinion of Barrow, far exceeded any thing which he had the opportunity of seeing in the vast empire of China. The surrounding mountains are highly picturesque, and the valleys covered with trees of various kinds, among which are the *laurus camphora*, *croton sebiferum*, and *thuya orientalis*. In the middle of the lake are two islands, to which company generally resort after having amused themselves with rowing, and in which a temple and several pleasure-houses have been built for their reception. The emperor has a small palace in the neighbourhood. This city has a garrison of 3000 Chinese, under the command of the viceroy, and 3000 Tartars, commanded by a general of the same nation. It has under its jurisdiction seven cities of the second and third class.

HANGING, a common name given to the method of inflicting death on criminals by suspending them by the neck.—Physicians are not agreed as to the manner in which death is brought on by hanging. De Haen hanged three dogs, which he afterwards opened. In one, nothing remarkable appeared in the lungs. In another, from whom half an ounce of blood was taken from the jugular vein, the dura and pia mater were of the natural appearance; but the lungs were much inflamed. In the third, the meninges were sound, and there was no effusion of blood in the ventricles of the brain, but the left lobe of the lungs was turgid with blood. Wepfer, Litttræus, Alberti, Brubierius, and Boerhaave, affirm that hanged animals die apoplectic. Their arguments for this are chiefly drawn from the livid colour of the face; from the turgescency of the vessels of the brain; the inflammation of the eyes; and from the sparks of fire which those who have survived hanging allege they have seen before their eyes. On the contrary, Bonetus, Petit, Haller, and Lancisi, from observing that death is occasioned by any small body falling into the glottis, have ascribed it to the stoppage of respiration. Others, deeming both these causes ill-founded, have ascribed it to a luxation of the vertebræ of the neck.—De Haen adduces the authority of many eminent authors to prove the possibility of recovering hanged persons; and observes, in general,

I i

Hangings
H
Hannibal

neral, that with bleeding in the jugular vein, and anointing the neck with warm oil, the same remedies are to be employed in this case as for the recovery of drowned people. See DROWNING.

HANGINGS, denote any kind of drapery hung up against the walls or wainscoting of a room.

Paper-HANGINGS. See *PAPER-Hangings.*

Wove-HANGINGS. See *TAPESTRY.*

HANGCLIFF, a remarkable point of land on the east coast of the largest of the Shetland islands. It is frequently the first land seen by ships in northern voyages. Captain Phipps determined its situation to be in W. Long. 56' 30". N. Lat. 60° 9'.

HANNIBAL, a famous Carthaginian general, of whose exploits an account is given under the articles **CARTHAGE** and **ROME**. After having had the misfortune to lose a sea-fight with the Rhodians, through the cowardice of Apollonius one of the admirals of Antiochus the Great, he was forced to fly into Crete, to avoid falling into the hands of the Romans. On his arrival in this island, he took sanctuary among the Gortynii; but as he had brought great treasure along with him, and knew the avarice of the Cretans, he thought proper to secure his riches by the following stratagem. He filled several vessels with melted lead, just covering them over with gold and silver. These he deposited in the temple of Diana, in the presence of the Gortynii, with whom, he said, he trusted all his treasure: Justin tells us, that he left this with them as a security for his good behaviour, and lived for some time very quietly in these parts. He took care, however, to conceal his riches in hollow statues of brass; which, according to some, he always carried along with him; or, as others will have it, exposed in a public place as things of little value. At last he retired to the court of Prusias king of Bithynia, where he found means to unite several of the neighbouring states with that prince in a confederacy against Eumenes king of Pergamus, a professed friend to the Romans; and during the ensuing war gave Eumenes several defeats, more through the force of his own genius than the valour of his troops. The Romans having received intelligence of the important services performed by Hannibal, immediately dispatched T. Quintius Flaminius as an ambassador to Prusias, in order to procure his destruction. At his first audience, he complained of the protection given to that famous general; representing him "as the most inveterate and implacable enemy the Romans ever had; as one who had ruined both his own country and Antiochus, by drawing them into a destructive war with Rome."—Prusias, in order to ingratiate himself with the Romans, immediately sent a party of soldiers to surround Hannibal's house, that he might find it impossible to make his escape. The Carthaginian, having before discovered that no confidence was to be reposed in Prusias, had contrived seven secret passages from his house, in order to evade the machinations of his enemies, even if they should carry their point at the Bithynian court. But guards being posted at these, he could not fly, though, according to Livy, he attempted it. Perceiving, therefore, no possibility of escaping, he had recourse to poison, which he had long reserved for such a melancholy occasion. Then taking it in his hand, "Let us (said he) deliver the Romans from the dis-

quietude with which they have long been tortured; since they have not patience to wait for an old man's death. Flaminius will not acquire any reputation or glory by a victory gained over a betrayed and defenceless person. This single day will be a lasting testimony of the degeneracy of the Romans. Their ancestors gave Pyrrhus intelligence of a design to poison him, that he might guard against the impending danger, even when he was at the head of a powerful army in Italy; but they have deputed a person of consular dignity to excite Prusias impiously to murder one who has taken refuge in his dominions, in violation of the laws of hospitality." Then having denounced dreadful imprecations against Prusias, he drank the poison, and expired at the age of 70 years. Cornelius Nepos acquaints us, that he put an end to his life by a subtle poison which he carried about with him in a ring. Plutarch relates, that, according to some writers, he ordered a servant to strangle him with a cloak wrapped about his neck; and others say, that, in imitation of Midas and Themistocles, he drank bull's blood.

With respect to the character of this general, it appears to have been in military affairs what Demosthenes was in oratory, or Newton in mathematics; namely, absolutely perfect, in which no human wisdom could discover a fault, and to which no man could add a perfection. Rollin hath contrasted his character with that of Scipio Africanus. He enumerates the qualities which make a complete general; and having then given a summary of what historians have related concerning both commanders, is inclined to give the preference to Hannibal. "There are, however, (he says), two difficulties which hinder him from deciding; one drawn from the characters of the generals whom Hannibal vanquished; the other from the errors he committed. May it not be said (continues our author), that those victories which made Hannibal so famous, were as much owing to the imprudence and temerity of the Roman generals, as to his bravery and skill? When a Fabius and a Scipio were sent against him, the former stopped his progress, the latter conquered him."

These reasons have been answered by Mr Hooke, who hath taken some pains to vindicate Hannibal's character, by fully and fairly comparing it with that of Scipio Africanus, and other Roman commanders. "I do not see (says he) why these difficulties should check our author's inclination to declare in favour of the Carthaginian. That Fabius was not beaten by Hannibal, we cannot much wonder, when we remember how steadily the old man kept to his resolution never to fight with him. But from Fabius's taking this method to put a stop to the victories of the enemy, may we not conclude that he knew no other, and thought Hannibal an overmatch for him? And why does our author forget Publius Scipio (Africanus's father), a prudent and able general, whom Hannibal vanquished at the Ticin? Livy relates some victories of Hannibal over the celebrated Marcellus; but neither Marcellus nor any other general ever vanquished Hannibal before the battle of Zama, if we may believe Polybius (lib. xv. c. 16.). Terentius Varro, indeed, is represented as a headstrong rash man; but the battle of Cannæ was not lost by his imprudence. The order

Hannibal

Hannibal order in which he drew up his army is nowhere con-
Hannover. demned; and Chevalier Folard thinks it excellent. And as to the conduct of the battle, Æmilius Paulus, a renowned captain, and a disciple of Fabius, had a greater share in it than his colleague. The imprudence with which Varro is taxed, was his venturing, contrary to his colleague's advice, with above 90,000 men, to encounter in a plain field an enemy who had only 50,000, but was superior in horse. And does not the very advice of Æmilius, and the charge of temerity on Varro for not following it, imply a confession of Hannibal's superiority in military skill over Æmilius as well as Varro? It ought likewise to be observed, that Hannibal's infantry had gained the victory over the Roman infantry, before this latter suffered any thing from the Carthaginian cavalry. It was otherwise when Scipio gained the victory at Zama. His infantry would probably have been vanquished but for his cavalry. Hannibal, with only his third line of foot (his Italian army), maintained a long fight against Scipio's three lines of foot; and seems to have had the advantage over them, when Masinissa and Lælius, with the horse, came to their assistance. Polybius indeed says, that Hannibal's Italian forces were equal in number to all Scipio's infantry; but this is contradicted by Livy, and is not very probable. The authority of Polybius, who was an intimate friend of Scipio Æmilianus, is, I imagine, of little weight in matters where the glory of the Scipios is particularly concerned. His partiality and flattery to them are, in many instances, but too visible."

Our author then proceeds to show, that Hannibal was not guilty of any of the faults laid to his charge as a general; and having contrasted the moral characters of the two generals with each other, makes it evident, that as a man, as well as a general, Hannibal had greatly the advantage of his rival. See *Hooke's Roman History*, vol. iv. p. 151. *et. seq.*

HANNO, general of the Carthaginians, was commanded to sail round Africa. He entered the ocean through the straits of Gibraltar, and discovered several countries. He would have continued his navigation, had it not been for want of provisions. He wrote an account of his voyage, which was often quoted, but not much credited. Sigismund Gelenius published it in Greek at Basil, by Frobenius, in 1533. He lived, according to Pliny, when the affairs of the Carthaginians were in the most flourishing condition; but this is a very indeterminate expression.

HANOVER, formerly an electoral state, now a kingdom of Germany, of which the king of Great Britain is king.—Though the house of Hanover is the last that was raised to the electoral and kingly dignity in the empire, it may vie with any in Germany for the antiquity and nobleness of its family.

The present kingdom of Hanover is bounded on the north by the duchy of Oldenburg, by Holstein and Lunenburg, on the east by Prussian Saxony, on the south by the Prussian dominions and Hesse-Cassel, and on the west by the kingdom of the Netherlands. It contains about 14,720 square English miles, and in 1818 its population was 1,333,632 souls.

The principalities of Kalenburg, Göttingen, and Grubenhagen, are very mountainous, especially in their southern divisions. The other provinces form a part of the extensive plain which commences on the shores

of the German ocean, and terminates on the frontiers of Russia. The whole plain is a sandy soil, resting on a bed of granite, and is generally sterile, except on the banks of the rivers. The most considerable mountains are those of the Hartz Forest, which extend beyond the limits of the kingdom. The Bruchberg, the highest summit of these, has an elevation of 3020 feet. These mountains are covered with wood, and abound in minerals.

In consideration of the great services performed by Ernest Augustus, duke of Brunswick-Hanover, in the wars which the emperor Leopold had with Louis XIV. that emperor conferred the dignity of an elector of the holy Roman empire upon him and his heirs male, of which he received the investiture on the 19th of December 1692. This new creation met with great opposition both in the electoral college and the college of princes: at last, by a conclusion of the three colleges on the 30th of January 1708, it was unanimously determined, that the electoral dignity should be confirmed to the duke of Hanover and his heirs male; but it was added, that if, while that electoral dignity subsisted, the Palatine electorate should happen to fall into the hands of a Protestant prince, the first Catholic elector should have a supernumerary vote.

The princes of this house had their seat in the college of princes, immediately after those of the electoral houses; each branch having a vote. The elector, besides his seat in the electoral college, was invested with the office of arch standard-bearer of the empire; but this being disputed with him by the duke of Wirtemberg, the elector Palatine having obtained the office of arch-steward, yielded that of arch-treasurer to the elector of Hanover, who was confirmed in this dignity by a decree of the diet of the 13th of January 1710.

The government of Hanover is a monarchy, and the prince is deemed to be of age at 18. The legislative power is shared between the prince and the assembly of the states, consisting of 102 deputies chosen from the three bodies of the clergy, nobility, and burgesses. The ministers are known, however, to have the nomination of the greater number of the members; and to make sure of their servility, three-fourths of them have places under the crown. No government can be more mild; and an air of content is spread over all the inhabitants. The High Court of Justice, and the Regency, are the principal courts of justice; besides which, every province has its municipal administration with the inferior divisions into bailiwicks, &c. The police is excellent, and justice fairly administered.

Lutheranism is the established religion; but all others enjoy a perfect toleration, and are publicly exercised. Difference in religious sentiments here gives no interruption to that harmony which should subsist among fellow citizens. There are 750 Lutheran parishes, 14 Reformed communities, a Romish college, a convent, and some Catholic churches.

Literature is in a very advanced state throughout these dominions. The university of Göttingen is deservedly celebrated; and contains about 800 students of different nations, and 60 professors. There are besides several colleges, and a number of well established schools, throughout the electorate. In general, education is much attended to.

Although there are various tracts of heath and

Hanover
Hanse-
towns.

marshy ground, the soil in general produces abundance of corn, fruits, hemp, flax, tobacco, madder, and some wine. There are several large salt-works. A good deal of cattle are reared, and a great number of excellent horses. Most metals and minerals are found here. The forests furnish sufficient timber, and large quantities of pitch and tar. The natural productions of the electorate furnish ample materials for commerce, so as to prevent the balance being against them, although their manufactures are not sufficient for consumption. Cattle, horses, salt, wrought iron, and fuel, are principal articles of export. Bremen is one of the greatest commercial towns in Germany.

The king of Hanover is descended from the ancient family of the Guelphs, dukes and electors of Bavaria; one of whom, Henry the Lion, in 1140, married Maude, eldest daughter of King Henry (Plantagenet) II. of England. Their son William succeeded to Brunswic-Lunenburg, and his son Otho was created duke thereof. The dominions descended in a direct line to Ernest, who divided them upon his death in 1546 into two branches, that of Brunswick-Lunenburg Wolfenbuttle, and Brunswic-Lunenburg Zell. The possessor of the latter, Ernest Augustus, was in 1692 raised to the dignity of an elector; before which he was head of the college of German princes. Ernest married Sophia, daughter of Frederic, elector Palatine and king of Bohemia, by Elizabeth, daughter of James I. king of England. Sophia being the next Protestant heir to the house of Stuart, the parliament fixed the crown of Great Britain upon her on Queen Anne's demise; and George Louis, her elder son, became king of Great Britain in consequence thereof; since which the electors of Hanover have filled the British throne. See HANOVER, SUPPLEMENT.

HANOVER is also the name of the capital of the above electorate; and is agreeably situated in a sandy plain on the river Leyne, in E. Long. 10. 5. N. Lat. 52. 5. It is a large well-built town, pretty well fortified, and contains about 24,000 inhabitants. It is noted for a particular kind of beer, reckoned excellent in these parts. In 1803, when the war between Britain and France broke out, this capital, as well as the electorate, was seized by the French, and subsequently given up to Prussia. It was afterwards in part annexed to the kingdom of Westphalia, but was delivered from the French yoke in 1813, and raised to the rank of a kingdom the following year.

HANSE, or HANS, an ancient name for a society or company of merchants; particularly that of certain cities in Germany, &c. hence called *Hanse-towns*. See *HANSE-TOWNS*.—The word *hanse* is obsolete High Dutch or Teutonic; and signifies "alliance, confederacy, association," &c. Some derive it from the two German words, *am-see*, that is, "on the sea;" by reason the first hanse-towns were all situated on the sea-coast; whence the society is said to have been first called *am see stenen*, that is, "cities on the sea;" and afterwards, by abbreviation, *hansee*, and *hanse*.

HANSE-TOWNS. The hanseatic society was a league between several maritime cities of Germany, for the mutual protection of their commerce. Bremen and Amsterdam were the two first that formed it; whose trade received such advantage by their fitting out two men of war in each to convoy their ships, that more

cities continually entered into the league: even kings and princes made treaties with them, and were often glad of their assistance and protection; by which means they grew so powerful both by sea and land, that they raised armies as well as navies, enjoyed countries in sovereignty, and made peace or war, though always in defence of their trade, as if they had been an united state or commonwealth.

At this time also abundance of cities, though they had no great interest in trade, or intercourse with the ocean, came into their alliance for the preservation of their liberties: so that in 1200 we find no less than 72 cities in the list of the towns of the Hanse; particularly Bremen, Amsterdam, Antwerp, Rotterdam, Dort, Bruges, Ostend, Dunkirk, Middleburgh, Calais, Rouen, Rochelle, Bourdeaux, St Malo, Bayonne, Bilbao, Lisbon, Seville, Cadiz, Carthage, Barcelona, Marseilles, Leghorn, Naples, Messina, London, Lubec, Rostock, Stralsund, Stetin, Wismar, Konigsberg, Dantzic, Elbing, Marienburg.

The alliance was now so powerful, that their ships of war were often hired by other princes to assist them against their enemies. They not only awed, but often defeated, all that opposed their commerce; and particularly in 1358, they took such revenge of the Danish fleet in the Sound, for having interrupted their commerce, that Waldemar III. then king of Denmark, for the sake of peace, gave them up all Schonen for 16 years; by which they commanded the passage of the Sound in their own right.—In 1428 they made war on Erick king of Denmark with 250 sail, carrying on board 12,000 men. These so ravaged the coast of Jutland, that the king was glad to make peace with them.

Many privileges were bestowed upon the hanse-towns by Louis XI. Charles VIII. Louis XII. and Francis I. kings of France; as well as by the emperor Charles V. who had divers loans of money from them; and by King Henry III. who also incorporated them into a trading body, in acknowledgment for money which they advanced to him, as well as for the good services they did him by their naval forces in 1206.

These towns exercised a jurisdiction among themselves; for which purpose they were divided into four colleges or provinces, distinguished by the names of their four principal cities, viz. Lubec, Cologne, Brunswick, and Dantzic, wherein were held their courts of judicature. They had a common stock or treasury at Lubec, and power to call an assembly as often as necessary.—They kept magazines or warehouses for the sale of their merchandises in London, Bruges, Antwerp, Berg in Norway, Revel in Livonia, Novogorod in Muscovy, which were exported to most parts of Europe, in English, Dutch, and Flemish bottoms. One of their principal magazines was at London, where a society of German merchants was formed, called the *steelyard company*. To this company great privileges were granted by Edward I. but revoked by act of parliament in 1552 in the reign of Edward VI. on a complaint of the English merchants that this company had so engrossed the cloth-trade, that in the preceding year they had exported 50,000 pieces, while all the English together had shipped off but 1100. Queen Mary, who ascended the throne the year following, having resolved to marry Philip, the emperor's son,

Hanse-
towns.

Hanse-
towns,
Hanway.

suspended the execution of the act for three years: but after that term, whether by reason of some new statute, or in pursuance of that of King Edward, the privileges of that company were no longer regarded, and all efforts of the hanse-towns to recover this loss were in vain.

Another accident that happened to their mortification was while Queen Elizabeth was at war with the Spaniards. Sir Francis Drake happening to meet 60 ships in the Tagus, loaded with corn belonging to the hanse-towns, took out all the corn as contraband goods, which they were forbidden to carry by their original patent. The hanse-towns having complained of this to the diet of the empire, the queen sent an ambassador thither to declare her reasons. The king of Poland likewise interested himself in the affair, because the city of Dantzic was under his protection. At last, though the queen strove hard to preserve the commerce of the English in Germany, the emperor excluded the English company of merchant-adventurers, who had considerable factories at Stade, Embden, Bremen, Hamburg, and Elbing, from all trade in the empire. In short, the hanse-towns, in Germany in particular, were not only in so flourishing, but in so formidable a state, from the 14th to the 16th century, that they gave umbrage to all the neighbouring princes, who threatened a strong confederacy against them; and, as the first step towards it, commanded all the cities within their dominion or jurisdiction to withdraw from the union or hanse, and be no farther concerned therein. This immediately separated all the cities of England, France, and Italy, from them. The hanse, on the other hand, prudently put themselves under the protection of the empire; and as the cities just now mentioned had withdrawn from them; so they withdrew from several more, and made a decree among themselves, that none should be admitted into their society but such as stood within the limits of the German empire, or were dependent thereon: except Dantzic, which continued a member, though in nowise dependent on the empire, only it had been summoned formerly to the imperial diet. By this means they maintained their confederacy for the protection of their trade, as it was begun, without being any more envied by their neighbours. Hereby likewise they were reduced to Lubec, Bremen, Hamburg, and Dantzic; in the first of which they kept their register, and held assemblies once in three years at least. But this hanse or union has for some time been dissolved; and now every one of the cities carries on a trade separately for itself, according to the stipulation in such treaties of peace, &c. as are made for the empire betwixt the emperor and other potentates.

HANWAY, JONAS, eminent for his benevolent designs and useful writings, was born at Portsmouth in Hampshire on the 12th of August 1712. His father, Mr Thomas Hanway, was an officer in the naval service, and for some years store-keeper to the dockyard at that place. He was deprived of his life by an accident; and left his widow with four children, Jonas, William, Thomas, and Elizabeth, all of a very tender age. Mrs Hanway coming to London after the death of her husband, put Jonas to school, where he learned writing and accounts, and made some proficiency in Latin. At the age of 17 he was sent to Lisbon, where he arrived in June 1729, and was bound apprentice to

a merchant in that city. His early life, we are informed, was marked with that discreet attention to business, and love of neatness and regularity, which afterwards distinguished his character. At Lisbon his affections were captivated by a lady, then celebrated for her beauty and mental accomplishments: but she, preferring another for her husband, returned to England, and spent the latter part of her life in London with her family, on terms of friendship with Mr Hanway.—On the expiration of Mr Hanway's apprenticeship, he entered into business at Lisbon as a merchant or factor; but did not remain there long before he returned to London.

He soon after connected himself as a partner in Mr Dingley's house in St Petersburg; where he arrived on the 10th of June 1743. The trade of the English nation over the Caspian sea into Persia at this period had been entrusted to the care of Mr Elton, who, not content with the pursuit of commercial affairs, had indelicately engaged in the service of Nadir Shah to build ships on the Caspian after the European manner. This had alarmed the merchants in the Russian trade, and a resolution was formed that one of their body should make a journey into Persia. On this occasion Mr Hanway offered his service, and was accepted. He set out on the 10th of September; and after experiencing a variety of hazards in that kingdom during a course of 12 months, returned to St Petersburg January 1. 1745, without being able to establish the intended trade by the Caspian, partly through the jealousy of the Russian court on account of Elton's connections with the Persians, and partly by the troubles and revolutions of the latter kingdom.

Though Mr Hanway's conduct during this expedition seems to have been directed by the strictest rules of integrity, yet some difficulties arose in settling his demands on his employers. These, however, in the end were referred to the determination of impartial arbitrators, who at length decided in his favour. "I obtained (he says) my own; and as to any other personal advantage, it consisted in exercising my mind in patience under trials, and increasing my knowledge of the world." He now settled at St Petersburg; where he remained five years, with no other variations in his life than such as may be supposed to occur in the dull round of a mercantile employment. During this time he interested himself greatly in the concerns of the merchants who had engaged in the Caspian trade: but the independence he had acquired having excited a desire to see his native country, he, after several disappointments which prevented him from accomplishing his wish, left St Petersburg on the 9th of July 1750. On his arrival in his native country, he did not immediately relinquish his mercantile connections, though he seems to have left Russia with that view. He employed himself some time as a merchant; but afterwards, more beneficially to the world, as a private gentleman. In 1753 he published "An Historical Account of the British trade over the Caspian sea; with a Journal of Travels from London through Russia into Persia; and back again through Russia, Germany, and Holland. To which are added, the Revolutions of Persia during the present century, with the particular History of the great Usurper Nadir Kouli," 4 vols 4to: a work which was received,

Hanway.

ceived, as it deserved to be, with great attention from the public. In 1754, we find Mr Hanway commending a plan offered for the advantage of Westminster, and suggesting hints for the further improvement of it, in "A Letter to Mr John Spranger, on his excellent Proposal for Paving, Cleansing, and Lighting the Streets of Westminster, &c." 8vo. A few years afterwards, when a scheme of the like kind was carried into effect, many of Mr Hanway's ideas, thrown out in this pamphlet, were adopted. In 1756, he printed "A Journal of Eight Days Journey from Portsmouth to Kingston upon Thames, with an Essay upon Tea;" which was afterwards reprinted in two volumes 8vo, 1757.

At this juncture, Great Britain being on the eve of a war with France, the event of which was very important to the nation at large, and required every effort of patriotism and prudence to ward off the impending danger, Mr Hanway published "Thoughts on the Duty of a good Citizen with regard to War and Invasion, in a Letter from a Citizen to his Friend," 8vo. About the same time, several gentlemen formed a plan which was matured and made perfect by the assiduity of Mr Hanway, for providing the navy with sailors, by furnishing poor children with necessaries to equip them for the service of their country. The success and propriety of this scheme soon became apparent. Mr Hanway wrote and published three pamphlets on this occasion; and the treasurer of the Society, accompanied by Mr Hanway, having waited on the king, the Society received 1000l. from his majesty, 400l. from the prince of Wales, and 200l. from the princess dowager. This excellent institution through life was the favourite object of Mr Hanway's care, and continued to flourish under his auspices greatly to the advantage of the community. In 1758 he became an advocate for another charitable institution, which derived considerable emolument from his patronage of it. This was the Magdalen Charity; and to assist it he published "A Letter to Robert Dingley, Esq. being a proposal for the Relief and Employment of friendless Girls and repenting Prostitutes," 4to. He also printed other small performances on the same subject.

In 1759, Mr Hanway wrote "Reasons for an Augmentation of at least Twelve Thousand Mariners, to be employed in the Merchants Service and Coasting Trade, in 33 Letters to Charles Gray, Esq. of Colchester, 4to." The next year he published several performances, viz. 1. "A candid historical Account of the Hospital for the reception of exposed and deserted young Children; representing the present Plan of it as productive of many Evils, and not adapted to the Genius and Happiness of this Nation," 8vo; which being answered by an anonymous Letter from Halifax in "Candid Remarks, 8vo 1760," Mr Hanway replied to it, and the Remarker rejoined. 2. "An Account of the Society for the Encouragement of the British Troops in Germany and North America, &c." 8vo. 3. "Eight Letters to — Duke of —, on the Custom of Vails giving in England," 8vo. This practice of giving vails had arrived at a very extravagant pitch, especially among the servants of the great. It was Mr Hanway who answered the kind reproach of a friend in a high station for not coming oftener to dine with

him, by saying, "Indeed I cannot afford it." The nobleman to whom the above letters were addressed was the duke of Newcastle. The letters are written in that humorous style which is most attractive of general notice, and was best adapted to the subject. It was Sir Timothy Waldo that first put Mr Hanway on this plan. Sir Timothy had dined with the duke of N—, and, on his leaving the house, was contributing to the support and insolence of a train of servants who lined the hall; and at last put a crown into the hand of the cook, who returned it, saying, "Sir, I do not take silver."—"Don't you indeed!" said the worthy baronet, putting it in his pocket: "then I do not give gold." Among the ludicrous circumstances in Mr Hanway's letters is one which happened to himself. He was prying the servants of a respectable friend for a dinner which their master had invited him to, one by one as they appeared; "Sir, your great coat;" a shilling—"Your hat;" a shilling—"Stick;" a shilling—"Umbrella;" a shilling—"Sir, your gloves;"—"Why, friend, you may keep the gloves; they are not worth a shilling." In 1761, Mr Hanway produced "Reflections, Essays, and Meditations on Life and Religion; with a collection of Proverbs, and 18 Letters written occasionally on several subjects," in 2 vols 8vo.

The many useful and public-spirited plans which Mr Hanway had promoted for the welfare of the community, had now rendered his character most respectably popular, while his disinterestedness, and the sincerity of his intentions, were conspicuous to all. Five citizens of London, of whom Mr Hoare the banker was one, waited on Lord Bute, at that time the minister: and, in their own names, and in the names of their fellow-citizens, requested that some notice might be taken of a man, who, at the expence of his own private fortune, and unremitting application, had rendered so many and such meritorious services to his country. In consequence of this request, he was in July 1762 appointed by a patent one of the commissioners for victualling the navy; a post which he held above 21 years. The next act of public beneficence in which we find him engaged is the collection of money for the sufferers by the fire which happened at Montreal, in the province of Quebec, in May 1765, when a fourth part of the city was consumed. On this occasion Mr Hanway, in conjunction with two other gentlemen, collected 8415l.—The very next year a dreadful fire broke out in Bridge-Town in Barbadoes, which consumed buildings and property to the amount of near 100,000l. A subscription was opened, in which Mr Hanway was a principal actor, and 14,886l. were collected, and transmitted to a committee appointed at Barbadoes to distribute it to the unfortunate sufferers. At subsequent periods he continued to interest himself in various other plans for relieving the distressed, and promoting the good, of different classes of the community. His attention was particularly directed towards alleviating the miseries of young chimney-sweepers. Besides the distresses of these helpless beings, which are open to general observation, such as a contortion of the limbs, and the prevention of their growth, they are liable to a disease peculiar to their occupation, now known by the name of the *chimney-sweepers cancer*. Four children have been brought together into a workhouse, all afflicted with this dreadful

ful and incurable disease. After much inquiry and consideration he published, in 1773, "The State of the Chimney-sweepers Young Apprentices; showing the wretched Condition of these distressed Boys; the ill Conduct of such masters as do not observe the Obligation of Indentures; the Necessity of a strict Inquiry in order to support the civil and religious Rights of these apprentices," 12mo. This small pamphlet has already been productive of some advantages to the objects intended to be benefited by it. The succeeding year, 1774, he enlarged a former publication, entitled "Advice from a Farmer to his Daughter, &c. and republished it under the title of "Virtue in Humble Life: containing Reflections on the reciprocal Duties, of the Wealthy and Indigent, the Master and the Servant," 2 vols 8vo; a work deserving the particular consideration of every magistrate. This edition in a few months being sold, he reprinted it in two quarto volumes, with a dedication to Mrs Montagu.

In 1783, finding his health decline, he determined to resign his office at the victualling board, which he did on the 2d of October that year; and immediately received a grant of his whole salary by way of a pension, to continue for life. This favour he owed to the esteem which his majesty, to whom he was personally known, entertained for him; excited by his various exertions in behalf of his country and mankind.—He was now released from his most material business, but did not think it would conduce to his happiness to lead an idle life. He engaged again in behalf of the chimney-sweepers boys; and promoted, by every means in his power, the establishment of Sunday-schools, which are now in a fair way to be adopted in every county in England. He likewise promoted a subscription for the relief of the many black poor people who wandered about the metropolis in extreme distress; and the lords of the treasury seconded the design, by directing money, as far as 1*l*. a head, to be issued to the committee, to enable them to send the blacks to such places abroad as might be fixed on. After encountering many obstacles, about 300 negroes were sent, properly accommodated with provisions and necessaries, to Africa, under the conduct of a person approved for that station. The object of this plan, besides relieving the misery of these poor people, was to prevent in time the unnatural connections between black persons and white, the disagreeable consequences of which make their appearance but too frequently in our streets.

In the summer of 1786 Mr Hanway's health declined so visibly that he thought it necessary to attend only to that. He had long felt the approach of a disorder in the bladder, which, increasing by degrees, caused a strangury; and at length, on the 5th of September 1786, put a period to a life spent almost entirely in the service of his fellow-creatures. On the 13th he was interred in the family-vault at Hanwell, being attended to the grave by a numerous retinue of friends; and after his death the public regard to his virtues was displayed by a subscription of several hundred pounds towards erecting a monument to perpetuate his memory.

Mr Hanway in his person was of the middle size, of a thin spare habit, but well shaped: his limbs were fashioned with the nicest symmetry. In the latter years

of his life he stooped very much; and when he walked found it conduce to ease to let his head incline towards one side: but when he went first to Russia at the age of 30, his face was full and comely, and his person altogether such as obtained for him the appellation of the *Handsome Englishman*. In his dress, as far as was consistent with his health and ease, he accommodated himself to the prevailing fashion. As it was frequently necessary for him to appear in polite circles on unexpected occasions, he usually wore dress clothes, with a large French bag. His hat, ornamented with a gold button, was of a size and fashion to be worn as well under the arm as on the head. When it rained, a small parasol defended his face and wig. Thus he was always prepared to enter into any company without impropriety or the appearance of negligence. His dress for set public occasions was a suit of rich dark brown; the coat and waistcoat lined throughout with ermine, which just appeared at the edges; and a small gold-hilted sword. As he was extremely susceptible of cold, he wore flannel under the linings of all his clothes, and usually three pairs of stockings. He was the first man who ventured to walk the streets of London with an umbrella over his head. After carrying one near 30 years, he saw them come into general use. The precarious state of his health when he arrived in England from Russia, made it necessary for him to use the utmost caution; and his perseverance in following the advice of the medical practitioners was remarkable. After Dr Lieberkyn physician to the king of Prussia had recommended milk as a proper diet to restore his strength, he made it the chief part of his food for 30 years; and though it at first disagreed with him, he persisted in trying it under every preparation that it was capable of till it agreed with his stomach. By this rigid attention and care, his health was established; his lungs acquired strength and elasticity, and it is probable he would have lived several years longer, if the disorder which was the immediate cause of his death had left him to the gradual decay of nature. His mind was the most active that it is possible to conceive; always on the wing, and never appearing to be weary. He rose in the summer at four or five, and in the winter at seven. Having always business before him, he was every day employed till the time of retiring to rest; and, when in health, was commonly asleep within two minutes after his lying down in bed.

Writing was his favourite employment, or rather amusement; and when the number of his literary works is considered, and that they were the produce only of those hours which he was able to snatch from public business, an idea may be formed of his application. But by leaving his work to transact his ordinary business, and afterwards recurring to it with new ideas, all his literary labours are defective in the arrangement of the matter, and appear to have too much of the miscellaneous in their composition. The original idea is sometimes left in the pursuit of one newly started, and either taken up again when the mind of the reader has almost lost it; or it is totally deserted. Yet those who are judges of literary composition say, that his language is well calculated to have the effect he desired on the reader, and impress him with the idea, that the author was a man of inflexible integrity, and wrote from the pure dictates of the heart. It is plain

Hanway.

Hanway. and unornamented, without the appearance of art or the affectation of singularity. Its greatest defect (say they) is a want of conciseness; its greatest beauty, an unaffected and genuine simplicity. He spoke French and Portuguese, and understood the Russ and modern Persic imperfectly. Latin he had been taught at school, but had not much occasion to cultivate it after he entered into life.

Mr Hanway, although never married himself, was yet an advocate for marriage, and recommended it to all young people. He thought it the most effectual restraint on licentiousness, and that an increase of unhappiness was by no means the natural consequence of an increase of domestic cares. A "local habitation," with the society of a sensible woman, the choice of unbiassed affection, he esteemed as the most engaging persuasive to the love of order and economy; without which he thought life, in whatever station, must be disjointed, perturbed, and unhappy. The lady who engaged his first affection was uncommonly handsome; and it is probable he was prevented from marrying only by his failing to obtain her, and the unsettled manner in which the first years of his life were spent: for he loved the society of women; and in the parties which frequently breakfasted at his house, the ladies usually made the greater portion of the company.

In his transactions with the world, he was always open, candid, and sincere. Whatever he said might be depended on with implicit confidence. He adhered to the strict truth, even in the manner of his relation; and no brilliancy of thought could induce him to vary from the fact: but although so frank in his own proceedings, he had seen too much of life to be easily deceived by others; and he did not often place a confidence that was betrayed. He did not, however, think the world so degenerate as is commonly imagined: "And if I did (he used to say), I would not let it appear; for nothing can tend so effectually to make a man wicked, or to keep him so, as a marked suspicion. Confidence is the reward of truth and fidelity, and these should never be exerted in vain." In his department of commissioner for victualling the navy he was uncommonly assiduous and attentive; and kept the contractors and persons who had dealings with the office at a great distance. He would not even accept a hare or pheasant or the smallest present, from any of them; and when any were sent him, he always returned them, not in a morose manner, as if he affected the excess of disinterestedness, but with some mild answer; such as, "Mr Hanway returns many thanks to Mr ——— for the present he intended him; but he has made it a rule not to accept any thing from any person engaged with the office: A rule which, whilst he acknowledges Mr ———'s good intentions, he hopes he will not expect him to break through." With all this goodness, Mr Hanway had a certain singularity of thought and manners, which was perhaps the consequence of his living the greater part of his life in foreign countries, and never having been married. He was not by any means an inattentive observer of the little forms of politeness: but as he had studied them in various realms, selecting those which he approved, his politeness differed from that of other people; and his conversation had an air of originality in it that was very pleasing.

Besides the works already mentioned in the course

of this article, Mr Hanway was the author of a great number of others; his different publications amounting altogether to between sixty and seventy. A complete list of them is given by his biographer Mr Pugh, from whose grateful and well-written performance this article has been chiefly extracted.

HAP, or HAPP, in *Law*, signifies to catch or snatch a thing. Thus we meet with, to hap the possession of a deed-poll. Littleton, fol. 8. also, to hap the rent. If partition be made between two parceners, and more land be allowed the one than the other, she that hath most of the land charges it to the other, and happeth the rent whereon assize is brought.

HAPPINESS, or FELICITY, absolutely taken, denotes the durable possession of perfect good without any mixture of evil; or the enjoyment of pure pleasure unalloyed with pain; or a state in which all the wishes are satisfied: In which senses, Happiness is known only by name upon the earth. The word *happy*, when applied to any state or condition of human life, will admit of no positive definition, but is merely a relative term: that is, when we call a man happy, we mean that he is happier than some others with whom we compare him; than the generality of others; or than he himself was in some other situation.

This interesting subject has been treated by many eminent writers, and in a great variety of ways; but by none does it appear to have been set in a clearer and more definite point of view than by Archdeacon Paley in the sixth chapter of his *Principles of Philosophy*. "In strictness (says that elegant writer), any condition may be denominated happy in which the amount or aggregate of pleasure exceeds that of pain; and the degree of happiness depends upon the quantity of this excess. And the greatest quantity of it, ordinarily attainable in human life, is what we mean by happiness, when we inquire or pronounce what human happiness consists in.

If any *positive* signification, distinct from what we mean by pleasure, can be affixed to the term *happiness*, it may be taken to denote a certain state of the nervous system in that part of the human frame in which we feel joy and grief, passions and affections. Whether this part be the heart, which the turn of most languages would lead us to believe; or the diaphragm, as Buffon, or the upper orifice of the stomach, as Van Helmont thought; or rather be a kind of fine network, lining the whole region of the præcordia, as others have imagined; it is possible not only that every painful sensation may violently shake and disturb the fibres at the time, but that a series of such may at length so derange the very texture of the system, as to produce a perpetual irritation, which will shew itself by fretfulness, restlessness, and impatience. It is possible also, on the other hand, that a succession of pleasurable sensations may have such an effect upon this subtle organization, as to cause the fibres to relax, and return into their place and order; and thereby to recover, or if not lost to preserve, that harmonious conformation which gives to the mind its sense of complacency and satisfaction. This state may be denominated *happiness*: And is so far distinguishable from pleasure, that it does not refer to any particular object of enjoyment, or consist like pleasure in the gratification of one or more of the senses; but is rather the secondary

Hanway
H
Happiness.

Happiness

condary effect which such objects and gratifications produce upon the nervous system, or the state in which they leave it. The comparative sense, however, in which we have explained the term *happiness*, is more popular; and in prosecuting the subject, we may consider, 1. What human happiness does not consist in; and, 2. What it does consist in.

I. *First*, then, happiness does not consist in the pleasures of sense, in whatever profusion or variety they be enjoyed. By the pleasures of sense are meant, as well the animal gratifications of eating, drinking, and that by which the species is continued, as the more refined pleasures of music, painting, architecture, gardening, splendid shows, theatric exhibitions, and the pleasures, lastly, of active sports, as of hunting, shooting, fishing, &c. For, 1. These pleasures continue but for a little while at a time. This is true of them all, especially of the grosser sort. Laying aside the preparation and the expectation, and computing strictly the actual sensation, we shall be surprised to find how inconsiderable a portion of our time they occupy, how few hours in the four and twenty they are able to fill up. 2. By repetition, they lose their relish. It is a property of the machine, for which we know no remedy, that the organs by which we perceive pleasure are blunted and benumbed, by being frequently exercised in the same way. There is hardly any one who has not found the difference between a gratification when new and when familiar, and any pleasure which does not become indifferent as it grows habitual. 3. The eagerness for high and intense delights takes away the relish from all others; and as such delights fall rarely in our way, the greater part of our time becomes from this cause empty and uneasy. There is hardly any delusion by which men are greater sufferers in their happiness, than by their expecting too much from what is called *pleasure*; that is, from those intense delights which vulgarly engross the name of pleasure. The very expectation spoils them. When they do come, we are often engaged in taking pains to persuade ourselves how much we are pleased, rather than enjoying any pleasure which springs naturally out of the object. And whenever we depend upon being vastly delighted, we always go home secretly grieved at missing our aim. Likewise, as hath been observed just now, when this humour of being prodigiously delighted has once taken hold of the imagination, it hinders us from providing for acquiescing in those gently soothing engagements, the due variety and succession of which are the only things that supply a continued stream of happiness.

The truth seems to be, that there is a limit at which these pleasures soon arrive, and from which they ever afterwards decline. They are by necessity of short duration, as the organs cannot hold on their emotions beyond a certain length of time; and if you endeavour to compensate for this imperfection in their nature by the frequency with which you repeat them, you lose more than you gain by the fatigue of the faculties and the diminution of sensibility. We have in this account said nothing of the loss of opportunities or the decay of faculties, which whenever they happen leave the voluptuary desitute and desperate; teased by desires that can never be gratified, and the memory of pleasures which must return no more. It will also be

VOL. X. Part I.

allowed by those who have experienced it, and perhaps by those alone, that pleasure which is purchased by the encumbrance of our fortune is purchased too dear; the pleasure never compensating for the perpetual irritation of embarrassed circumstances.

These pleasures, after all, have their value: and as the young are always too eager in their pursuit of them, the old are sometimes too remiss: that is, too studious of their ease to be at the pains for them which they really deserve.

Secondly, Neither does happiness consist in an exemption from pain, labour, care, business, suspense, molestation, and "those evils which are without;" such a state being usually attended not with ease, but with depression of spirits, a tastelessness in all our ideas, imaginary anxieties, and the whole train of hypochondriacal affections. For which reason it seldom answers the expectations of those who retire from their shops and counting-houses to enjoy the remainder of their days in leisure and tranquillity; much less of such as in a fit of chagrin shut themselves up in cloisters and hermitages, or quit the world and their stations in it, for solitude and repose.

Where there exists a known external cause of uneasiness, the cause may be removed, and the uneasiness will cease. But those imaginary distresses which men feel for want of real ones (and which are equally tormenting, and so far equally real), as they depend upon no single or assignable subject of uneasiness, so they admit oft-times of no application or relief. Hence a moderate pain, upon which the attention may fasten and spend itself, is to many a refreshment; as a fit of the gout will sometimes cure the spleen. And the same of any moderate agitation of the mind, as a literary controversy, a law-suit, a contested election, and above all gaming; the passion for which, in men of fortune and liberal minds, is only to be accounted for on this principle.

Thirdly, Neither does happiness consist in greatness, rank, or elevated station.

Were it true that all superiority afforded pleasure, it would follow, that by how much we are the greater, that is, the more persons we were superior to, in the same proportion, so far as depended upon this cause, we should be the happier; but so it is, that no superiority yields any satisfaction, save that which we possess or obtain over those with whom we immediately compare ourselves. The shepherd perceives no pleasure in his superiority over his dog; the farmer in his superiority over the shepherd; the lord in his superiority over the farmer; nor the king, lastly, in his superiority over the lord. Superiority, where there is no competition, is seldom contemplated; what most men indeed are quite unconscious of. But if the same shepherd can run, fight, or wrestle, better than the peasants of his village; if the farmer can show better cattle, if he keeps a better horse, or be supposed to have a longer purse than any farmer in the hundred; if the lord have more interest in an election, greater favour at court, a better house, or larger estate, than any nobleman in the county; if the king possess a more extensive territory, a more powerful fleet or army, a more splendid establishment, more loyal subjects, or more weight and authority in adjusting the affairs of nations, than any prince in Europe; in all these cases, the

K k

parties

†

Happiness. parties feel an actual satisfaction in their superiority. No superiority appears to be of any account but a superiority over a rival. This, it is manifest, may exist wherever rivalships do; and rivalships fall out amongst men of all ranks and degrees. The object of emulation, the dignity or magnitude of this object, makes no difference; as it is not what either possesses that constitutes the pleasure, but what one possesses more than the other. Philosophy smiles at the contempt with which the rich and great speak of the petty strifes and competitions of the poor; not reflecting that these strifes and competitions are just as reasonable as their own, and the pleasure which success affords the same.

It appears evident then, that happiness does not consist in greatness; since what are supposed to be the peculiar advantages of greatness, the pleasures of ambition and superiority, are in reality common to all conditions. But whether the pursuits of ambition be ever wise, whether they contribute more to the happiness or misery of the pursuers, is a different question; and a question concerning which we may be allowed to entertain great doubt. The pleasure of success is exquisite; so also is the anxiety of the pursuit, and the pain of disappointment; and what is the worst part of the account, the pleasure is short-lived. We soon cease to look back upon those whom we have left behind; new contests are engaged in, new prospects unfold themselves; a succession of struggles is kept up, whilst there is a rival left within the compass of our views and profession; and when there is none, the pleasure with the pursuit is at an end.

II. We have seen what happiness does *not* consist in. We are next to consider in what it *does* consist. In the conduct of life, the great matter is, to know before hand what will please us, and what pleasures will hold out. So far as we know this, our choice will be justified by the event. And this knowledge is more rare and difficult than at first sight it may seem to be: for sometimes pleasures, which are wonderfully alluring and flattering in the prospect, turn out in the possession extremely insipid; or do not hold out as we expected: at other times pleasures start up, which never entered into our calculation, and which we might have missed of by not foreseeing; from whence we have reason to believe, that we actually do miss of many pleasures from the same cause.

The original diversity of taste, capacity, and constitution, observable in the human species, and the still greater variety which habit and fashion have introduced, render it altogether impossible to propose any plan of happiness which will succeed to all, or any method of life which is universally eligible or practicable. All that can be said is, that there remains a presumption in favour of those conditions of life in which men generally appear most cheerful and contented. For though the apparent happiness of mankind be not always a true measure of their real happiness, it is the best measure we have.

Upon this principle, then, happiness appears to consist,

1. In the exercise of the social affections.—Those persons commonly possess good spirits who have about them many objects of affection and endearment; as wife, children, kindred, friends: and to the want of

these may be imputed the peevishness of monks and of such as lead a monastic life. Of the same nature with the indulgence of our domestic affections, and equally refreshing to the spirits, is the pleasure which results from acts of bounty and beneficence, exercised either in giving money, or in imparting to those who want it the assistance of our skill and profession.

2. Another main article of human happiness is, the exercise of our faculties, either of body or mind, in the pursuit of some engaging end.

It seems to be true, that no plenitude of present gratifications can make the possessor happy for a continuance, unless he have something in reserve, something to hope for and look forward to. This may be inferred from comparing the alacrity and spirits of men who are engaged in any pursuit which interests them, with the dejection and *ennui* of almost all who are either born to so much that they want nothing more, or who have *used up* their satisfactions too soon and drained the sources of them. It is this intolerable vacuity of mind which carries the rich and great to the horse-course and the gaming table; and often engages them in contests and pursuits, of which the success bears no proportion to the solicitude and expence with which it is sought.

The question now occurs, How we are to provide ourselves with a succession of pleasurable engagements? This requires two things: Judgment in the choice of ends adapted to our opportunities; and a command of imagination, so as to be able, when the judgment has made choice of an end, to transfer a pleasure to the *means*; after which the end may be forgotten as soon as we will. Hence those pleasures are most valuable, not which are most exquisite in the fruition, but most productive of engagement and activity in the pursuit.

A man who is in earnest in his endeavours after the happiness of a future state, has in this respect an advantage over all the world. For he has constantly before his eyes an object of supreme importance, productive of perpetual engagement and activity, and of which the pursuit (which can be said of no pursuit besides) lasts him to his life's end. Yet even he must have many ends beside the far end; but then they will conduct to that, be subordinate, and in some way or other capable of being referred to that, and derive their satisfaction, or an addition of satisfaction, from that.

Engagement is every thing. The more significant, however, our engagements are, the better; such as the planning of laws, institutions, manufactures, charities, improvements, public works, and the endeavouring by our interest, address, solicitations, and activity, to carry them into effect: or upon a smaller scale, the procuring of a maintenance and fortune for our families, by a course of industry and application to our callings, which forms and gives motion to the common occupations of life; training up a child; prosecuting a scheme for his future establishment; making ourselves masters of a language or a science; improving or managing an estate; labouring after a piece of preferment: and, lastly, any engagement which is innocent is better than none; as writing a book, building a house, laying out a garden, digging a fish-pond; even raising a cucumber or a tulip. Whilst the mind is taken up with the objects or business before it, we are commonly happy, whatever

Happiness.

Happiness. whatever the object or business be: when the mind is absent, and the thoughts are wandering to something else beside what is passing in the place in which we are, we are often miserable.

3. The art in which the secret of human happiness is a great measure consists, is to set the habits in such a manner, that every change may be a change for the better. The habits themselves are much the same; for whatever is made habitual becomes smooth, and easy, and indifferent. The return to an old habit is likewise easy, whatever the habit be. Therefore the advantage is with those habits which allow of indulgence in the deviation from them. The luxurious receive no greater pleasure from their dainties than the peasant does from his bread and cheese; but the peasant whenever he goes abroad finds a feast, whereas the epicure must be well entertained to escape disgust. Those who spend every day at cards, and those who go every day to plough, pass their time much alike; intent upon what they are about, wanting nothing, regretting nothing, they are both in a state of ease: But then, whatever suspends the occupation of the card-player distresses him; whereas to the labourer every interruption is a refreshment: and this appears in the different effect that the Sabbath produces upon the two, which proves a day of recreation to the one, but a lamentable burden to the other. The man who has learned to live alone, feels his spirits enlivened whenever he enters into company, and takes his leave without regret: another, who has long been accustomed to a crowd or continual succession of company, experiences in company no elevation of spirits, nor any greater satisfaction than what the man of a retired life finds in his chimney-corner. So far their conditions are equal: but let a change of place, fortune, or situation, separate the companion from his circle, his visitors, his club, common-room, or coffee-house, and the difference of advantage in the choice and constitution of the two habits will show itself. Solitude comes to the one clothed with melancholy: to the other it brings liberty and quiet. You will see the one fretful and restless, at a loss how to dispose of his time, till the hour comes round that he can forget himself in bed: the other easy and satisfied, taking up his book or his pipe as soon as he finds himself alone; ready to admit any little amusement that casts up, or to turn his hands and attention to the first business that presents itself; or content without either to sit still, and let his trains of thought glide indolently through his brain, without much use perhaps or pleasure, but without hankering after any thing better, and without irritation. A reader who has inured himself to books of science and argumentation, if a novel, a well-written pamphlet, an article of news, a narrative of a curious voyage, or the journal of a traveller, fall in his way, sits down to the repast with relish, enjoys his entertainment while it lasts, and can return when it is over to his graver reading without distaste. Another, with whom nothing will go down but works of humour and pleasantry, or whose curiosity must be interested by perpetual novelty, will consume a bookseller's window in half a forenoon; during which time he is rather in search of diversion than diverted: and as books to his taste are few and short, and rapidly read over,

the stock is soon exhausted, when he is left without resource from this principal supply of innocent amusement.

Happiness
||
Harangue.

So far as circumstances of fortune conduce to happiness, it is not the income which any man possesses, but the increase of income that affords the pleasure. Two persons, of whom one begins with 100l. and advances his income to 1000l. a-year; and the other sets off with 1000l. and dwindles down to 100l. may, in the course of their time, have the receipt and spending of the same sum of money: yet their satisfaction, so far as fortune is concerned in it, will be very different: the series and sum total of their incomes being the same, it makes a wide difference which end they begin at.

4. Happiness consists in health; understanding by health, not only freedom from bodily distempers, but also that tranquillity, firmness, and alacrity of mind, which we call *good spirits*. For the sake of health, according to this notion of it, no sacrifices can be too great. Whether it requires us to relinquish lucrative situations, to abstain from favourite indulgences, to controul intemperate passions, or undergo tedious regimens; whatever difficulties it lays us under, a man, who pursues his happiness rationally and resolutely, will be content to submit to. When we are in perfect health and spirits, we feel in ourselves a happiness independent of any particular outward gratification whatever, and of which we can give no account. This is an enjoyment which the Deity has annexed to life; and probably constitutes, in a great measure, the happiness of infants and brutes, especially of the lower and sedentary orders of animals, as of oysters, periwinkles, and the like.

The above account of human happiness will justify these two conclusions, which, although found in most books of morality, have seldom been supported by any sufficient reasons: 1. "That happiness is pretty equally distributed amongst the different orders of civil society; and, 2. That vice has no advantage over virtue, even with respect to this world's happiness."

HAQUE, in our old writers, a little hand-gun, prohibited to be used for destruction of game, &c. by statute 33 Hen. VIII. cap. 6. and 2 and 3 Ed. VI. cap. 14. There is also the half-haque, or demi-haque, within the said acts.

HARAM. See **SERAGLIO**.

HARAN, **CHARRAN**, or **CHARRÉ**, in Mesopotamia, a city celebrated for having been the place where Abraham first retreated after he left Ur (Gen. xi. 31, 32.); and where Terah, Abraham's father, died and was buried. Thither it was likewise that Jacob retired to Laban when he fled from the indignation of his brother Esau (id. xxvii. 45. xxviii. 10, &c.). Lastly, at Haran or Charré in Mesopotamia, Crassus the Roman general was defeated and killed by the Parthians. Haran was situated between the Euphrates and the river Chebar, at a considerable distance from the place where these two rivers join.

HARANGUE, a modern French name for a speech or oration made by an orator in public.—Menage derives the word from the Italian *aranga*, which signifies the same; formed, according to Ferrari, from *arringo*, "a just, or place of justing." Others derive it from

K k 2

the

Harangue
||
Harder-
wick.

the Latin *ara*, "altar;" by reason the first harangues were made before altars; whence the verse of Juvenal,

Aut Lugdunensis rhetor dicturus ad aram.

Harangues were usually made by the generals, previous to an engagement, both amongst the Greeks and Romans. An harangue on such occasions was called *allocutio*. See *ALLOCUTIO*.

The word is also frequently used in an ill sense, viz. for a too pompous, prolix, or unseasonable speech or declamation.

HARBINGER, an officer of the king's household, having four yeomen under him, who ride a day's journey before the court when it travels, to provide lodgings, &c.

HARBOROUGH, a town of Leicestershire, 84 miles from London. It is a great thoroughfare in the road to Derby, near the source of the river Welland; and was famous, in Camden's time, for its beast fair, where the best horses and colts are still sold. Its fairs are April 29. and Oct. 19. The market is on Tuesday, for the use of which the earl of Harborough built a neat market-house, at his own expence. Population 1704. W. Long. \circ . 56. N. Lat. 52. 20.

HARBOUR, a general name given to any sea-port or haven; as also to any place convenient for mooring shipping, although at a great distance from the sea. The qualities requisite in a good harbour are, that the bottom be entirely free from rocks or shallows; that the opening be of sufficient extent to admit the entrance or departure of large ships without difficulty; that it should have good anchoring ground, and be easy of access; that it should be well defended from the violence of the wind and sea; that it should have room and convenience to receive the shipping of different nations, and those which are laden with different merchandises; that it be furnished with a good light-house, and have variety of proper rings, posts, moorings, &c. in order to remove or secure the vessels contained therein; and, finally, that it have plenty of wood, and other materials for firing, besides hemp, iron, mariners, &c.

HARBURG, a small town of Germany, in the circle of Lower Saxony, and duchy of Lunenburg, seated on the river Elbe opposite to Hamburg. It was surrounded with walls in 1355; and 30 years after, a strong castle, which still remains, was built by the bishop. E. Long. 9. 56. N. Lat. 53. 28.

HARCOURT, a town of France, in the department of Calvados, about 12 miles south of Caen. From it a once noble family in France, derived their ducal title; and from it also, it is said, sprang the noble family of the same name in England.

HARDBERG, a town of Germany, in the duchy of Stiria, 52 miles south of Vienna. E. Long. 15. 46. N. Lat. 47. 22.

HARDENBERG, a town of Westphalia, in the duchy of Berg, 13 miles east-north-east of Dusseldorf. E. Long. 6. 50. N. Lat. 51. 19.

HARDENING, the giving a greater degree of hardness to bodies than they had before.

There are several ways of hardening iron and steel, as by hammering them, quenching them in cold water, &c. See *STEEL*.

Case-HARDENING. See *CASE-HARDENING*.

HARDERWICK, a town of the United Provinces,

in Dutch Guelderland. It is a well-boilt town, and the chief of the sea-ports of this province. It has several good buildings, particularly the great church, which is much admired. In 1648 the public school here was turned into an university. The French did it a great deal of damage in 1672; since which time it has been on the decline. E. Long. 5. 31. N. Lat. 52. 34.

HARDNESS, in bodies, a property directly opposite to fluidity; by which they resist the impression of any other substance, sometimes in an extreme degree. As fluidity has been found to consist in the motion of the particles of a body upon one another in consequence of a certain action of the universal fluid or elementary fire among them; we must conclude that hardness consists in the absence of this action, or a deficiency of what is called *latent heat*. This is confirmed by observing, that there is an intermediate state between hardness and fluidity, in which bodies will yield to a certain force, though they still make a considerable resistance. This is principally observed in the metals, and is the foundation of their ductility. It appears indeed that this last property, as well as fluidity, is entirely dependent on a certain quantity of latent heat absorbed, or otherwise acting within the substance itself; for all the metals are rendered hard by hammering, and soft by being put again into the fire and kept there for some time. The former operation renders them hot as well as hard; probably, as Dr Black observes, because the particles of metal are thus forced near one another, and those of fire squeezed out from among them. By keeping them for some time in the fire, that element insinuates itself again among the particles, and arranges them in the same manner as before, so that the ductility returns. By a second hammering this property is again destroyed, returning on a repetition of the heating or *annealing* as it is called; and so on, as often as we please.

Hardness appears to diminish the cohesion of bodies in some degree, though their fragility does not by any means keep pace with their hardness. Thus, glass is very hard and very brittle; but flint, though still harder than glass, is much less brittle. Among the metals, however, these two properties seem to be more connected, though even here the connection is by no means complete. Steel, the hardest of all the metals, is indeed the most brittle; but lead, the softest, is not the most ductile. Neither is hardness connected with the specific gravity of bodies; for a diamond, the hardest substance in nature, is little more than half the weight of the lightest metal. As little is it connected with the coldness, electrical properties, or any other quality with which we are acquainted; so that though the principle above laid down may be accepted as a general foundation for our inquiries, a great number of particulars remain yet to be discovered before we can offer any satisfactory explanation.

All bodies become harder by cold; but this is not the only means of their doing so, for some become hard by heat as well as cold. Thus, water becomes hard by cold when it is frozen, but it becomes much harder when its steam is passed over red-hot-iron, and it enters the substance of the metal, by an union with which it becomes almost as hard as glass.

Dr Quist and others have constructed tables of the hardness

Harder-
wick,
Hardness.

Hardness
||
Hare.

hardness of different substances. The method pursued in constructing these tables was by observing the order in which they were able to cut or make any impression upon one another. The following table, extracted from M. Magellan's edition of Cronstedt's Mineralogy, was taken from Dr Quist, Bergman, and Mr Kirwan. The first column shows the hardness, and the second the specific gravity.

Diamond from Ormus	-	20	—	3.7
Pink diamond	-	19	—	3.4
Bluish diamond	-	19	—	3.3
Yellowish diamond	-	19	—	3.3
Cubic diamond	-	18	—	3.2
Ruby	-	17	—	4.2
Pale ruby from Brazil	-	16	—	3.5
Ruby spinell	-	13	—	3.4
Deep blue sapphire	-	16	—	3.8
Ditto paler	-	17	—	3.8
Topaz	-	15	—	4.2
Whitish ditto	-	14	—	3.5
Bohemian ditto	-	11	—	2.8
Emerald	-	12	—	2.8
Garnet	-	12	—	4.4
Agate	-	12	—	2.6
Onyx	-	12	—	2.6
Sardonyx	-	12	—	2.6
Occidental amethyst	-	11	—	2.7
Crystal	-	11	—	2.6
Cornelian	-	11	—	2.7
Green jasper	-	11	—	2.7
Reddish yellow ditto	-	9	—	2.6
Schoerl	-	10	—	3.6
Tourmaline	-	10	—	3.0
Quartz	-	10	—	2.7
Opal	-	10	—	2.6
Chrysolite	-	10	—	3.7
Zeolite	-	8	—	2.1
Fluor	-	7	—	3.5
Calcareous spar	-	6	—	2.7
Gypsum	-	5	—	2.3
Chalk	-	3	—	2.7

HARDOUIN, JOHN, a learned French Jesuit in the beginning of the 18th century, known by the remarkable paradoxes he advanced in his writings; this in particular, That all the works of the ancient profane writers, except Cicero's works, Virgil's Georgics, Horace's satires and epistles, and Pliny's natural history, are mere forgeries. He died at Paris in 1729, aged 83. His principal works are, 1. An edition of Pliny's natural history, with notes, which is much esteemed. 2. An edition of the councils, which made much noise. 3. Chronology restored by medals, 4to. 4. A commentary on the New Testament, folio; in which he pretends that our Saviour and his apostles preached in Latin, &c.

HARDWICKE. See YORK.

HARE. See LEPUS, MAMMALIA Index.

The hare is a beast of venery, or of the forest, but peculiarly so termed in the second year of her age. There are reckoned four sorts of them, from the place of their abode: some live in the mountains, some in the fields, some in marshes, and some wander about everywhere. The mountain-hares are the swiftest, the field-

hares are not so nimble, and those of the marshes are the slowest; but the wandering hares are the most cunning in the paths and mazes of the fields, for, knowing the nearest ways, they run up the hills and rocks, to the confusion of the dogs. See HUNTING.

Hares and rabbits are very mischievous to new planted orchards, by peeling off the bark of the young trees for food. They do also the same sort of mischief to nurseries; for the prevention of which, some bind ropes about the trees up to a sufficient height; some daub them with tar; but though this keeps off the hares, it is itself mischievous to the trees; but this hurtful property of it is in some degree taken off by mixing any kind of fat or grease with it, and incorporating them well over the fire. This mixture is to be rubbed over the lower part of the trees in November, and will preserve them till that time the next year, without any danger from these animals. It is only in the hard weather in the winter season, when other food is scarce, that these creatures feed on the barks of trees.

People who have the care of warrens, pretend to make hares fat by stopping up their ears with wax, and rendering them deaf. The hare is so timorous a creature, that she is continually listening after every noise, and will run a long way on the least suspicion of danger; so that she always eats in terror, and runs herself out of flesh continually. These are both prevented by her feeding without apprehension.

Java HARE. See MUS, MAMMALIA Index.

HARES Ear. See BUPLEURUM, BOTANY Index.

HARE, Dr Francis, an English bishop, of whose birth we have no particulars, was bred at Eton school, and from that foundation became a member of King's college, Cambridge; where he had the tuition of the marquis of Blandford, only son of the illustrious duke of Marlborough, who appointed him chaplain-general to the army. He afterwards obtained the deanery of Worcester, and from thence was promoted to the bishopric of Chichester, which he held with the deanery of St Paul's to his death, which happened in 1740. He was dismissed from being chaplain to George I. in 1718, by the strength of party prejudices, in company with Dr Moss and Dr Sherlock, persons of distinguished rank for parts and learning. About the latter end of Queen Anne's reign he published a remarkable pamphlet, intitled, The difficulties and discouragements which attend the study of the Scriptures, in the way of private judgment: in order to show, that since such a study of the Scriptures is an indispensable duty, it concerns all Christian societies to remove, as much as possible, those discouragements. In this work, his manner appeared to be so ludicrous, that the convocation fell upon him, as if he were really against the study of the Holy Scriptures: and Whiston says, that finding this piece likely to hinder that preferment he was seeking for, he aimed to conceal his being the author. He published many pieces against Bishop Hoadley, in the Bangorian Controversy, as it is called; and also other learned works, which were collected after his death, and published in four vols 8vo. 2. An edition of Terence, with notes, in 4to. 3. The book of Psalms in the Hebrew, put into the original poetical metre, 4to. In this last work, he pretends to have discovered the Hebrew metre, which was supposed to be irretrievably lost. But his hypothesis, though defend-

Hare.

ed by some, yet has been confuted by several learned men, particularly by Dr Lowth in his *Metricæ Harleianæ brevis confutatio*, annexed to his lectures *De Sacra Poesi Hebræorum*.

HARESBURY, a town of Wiltshire, on the Willy, near Warminster, 94 miles from London, is in old records called *Heightsbury*, or *Heytsbury*; and now it is written Hatchbury. It was once the seat of the empress Maud. Here are fairs on May 14th and September 15th; and it has sent members to parliament ever since Henry VI. it being an ancient borough by prescription.

HARFLEUR, an ancient town of France, in the department of the Lower Seine; but is now a poor place, on account of its fortifications being demolished, and its harbour choked up. It was taken by the English, by assault, in the year 1415. It is seated on the river Lizarna, near the Seine, five miles from Havre de Grace, and 106 north-west of Paris. The number of inhabitants is about 1800. E. Long. o. 17. N. Lat. 49. 30.

HARIOT, or **HERIOT**, in *Law*, a due belonging to a lord at the death of his tenant, consisting of the best beast, either horse or cow, or ox, which he had at the time of his death; and in some manors the best goods, piece of plate, &c. are called hariots.

HARIOT, *Thomas*. See **HARRIOT**.

HARLECH, a town of Merionethshire, in North Wales. It is seated on a rock, on the sea-shore; and is but a poor place, though the shire-town, and sends a member to parliament. It had formerly a strong handsome castle, which was a garrison for Charles I. in the civil wars, for which reason it was afterwards demolished by the parliament. W. Long. 4. o. N. Lat. 54. 47.

HARLEIAN COLLECTION, a most valuable collection of useful and curious manuscripts, begun near the end of the 17th century, by Robert Harley of Bramton Bryan, Esq. in Herefordshire, afterwards earl of Oxford and lord high-treasurer; and which was conducted upon the plan of the great Sir Robert Cotton. He published his first considerable collection in August 1705, and in less than ten years he got together near 2500 rare and curious MSS. Soon after this, the celebrated Dr George Hicks, Mr Anstis garter king at arms, Bishop Nicolson, and many other eminent antiquaries, not only offered him their assistance in procuring MSS. but presented him with several that were very valuable. Being thus encouraged to perseverance by his success, he kept many persons employed in purchasing MSS. for him abroad, giving them written instructions for their conduct. By these means the MS. library was, in the year 1721, increased to near 6000 books, 14,000 original charters, and 500 rolls.

On the 21st of May 1724 Lord Oxford died: but his son Edward, who succeeded to his honours and estate, still farther enlarged the collection; so that when he died, June 16th 1741, it consisted of 8000 volumes, several of them containing distinct and independent treatises, besides many loose papers which have been since arranged and bound up in volumes; and above 40,000 original rolls, charters, letters patent, grants, and other deeds and instruments of great antiquity.

The principal design of making this collection was the establishment of a MS. English historical library, and the rescuing from destruction such national records

as had eluded the diligence of preceding collectors: but Lord Oxford's plan was more extensive; for his collection abounds also with curious MSS. in every science. This collection, which was purchased by government for 10,000l. is now in the British Museum; and an enumeration of its contents may be seen in the Annual Register, vi. 140, &c.

HARLEM, a town of the United Provinces, in Holland, situated on the river Sparren, in E. Long. 4. 29. N. Lat. 52. 22. It is a large and populous city, and stands near a lake of the same name, with which it has a communication, as well as with Amsterdam and Leyden, by means of several canals. Schemes have been often formed for draining of this lake, but were never put in execution. To the south of the town lies a wood, cut into delightful walks and vistas. The town is famous for the siege which it held out against the Spaniards for ten months in 1573; the townsmen, before they capitulated, being reduced to eat the vilest animals, and even leather and grass. The inhabitants corresponded with the prince of Orange for a considerable time by means of carrier-pigeons. Harlem, as is well known, claims the invention of printing; and in fact, the first essays of the art are indisputably to be attributed to Laurentius, a magistrate of that city. [See **LAURENTIUS**, and (*History of*) **PRINTING**.] Before the Reformation, Harlem was a bishop's see; the inhabitants amount to 40,000. An academy of sciences was founded here in 1752. Vast quantities of linen and thread are bleached here; the waters of the lake having a peculiar quality, which renders them very fit for that purpose.—A sort of phrensy with regard to flowers, particularly tulips, once prevailed here, in consequence of which they were sold at extravagant prices. The owner of a hyacinth which Dutens saw in flower in May 1771, refused 10,000 florins for it.

HARLEQUIN, in the Italian comedy, a buffoon, dressed in party-coloured clothes; answering much the same purpose as a merry-andrew or jack-pudding in our drolls, on mountebanks, stages, &c. We have also introduced the harlequin upon our theatres; and this is one of the standing characters in the modern grotesque or pantomime entertainments. The term took its rise from a famous Italian comedian who came to Paris under Henry III. and who frequenting the house of M. de Harlay, his companions used to call him Harlequino, q. d. little Harlay; a name which has descended to those of the same rank and profession.

HARLEY, **ROBERT**, earl of Oxford and Mortimer, was the eldest son of Sir Edward Harley, and born in 1661. At the Revolution, Sir Edward and his son raised a troop of horse at their own expence; and after the accession of King William and Queen Mary, he obtained a seat in parliament. His promotions were rapid. In 1702, he was chosen speaker of the house of commons; in 1704, he was sworn of Queen Anne's privy council, and the same year made secretary of state; in 1706, he acted as one of the commissioners for the treaty of union; and in 1710 was appointed a commissioner of the treasury, and chancellor and under-treasurer of the exchequer. A daring attempt was made on his life, March 8. 1711, by the marquis of Guiscard a French Papist; who, when under an examination before a committee of the privy council, stabbed him with a penknife. Of this wound, however, he soon recovered;

Harley
Harlot

ed; and was the same year created earl of Oxford, and lord high-treasurer, which office he resigned just before the queen's death. He was impeached of high treason in 1715, and committed to the Tower; but was cleared by trial, and died in 1724. His character has been variously represented, but cannot be here discussed. He was not only an encourager of literature, but the greatest collector in his time of curious books and MSS. his collection of which makes a capital part of the British Museum. See *HARLEIAN Collection*.

HARLING. See **HERLING**.

HARLINGEN, a sea-port town of the United Netherlands, in West Friesland. It stands on the coast of the Zuyder sea, at the mouth of a large canal, in E. Long. 5. 22. N. Lat. 53. 9. It was only a hamlet till about the year 1234, when it was destroyed by the sea; and being afterwards rebuilt, became a considerable town. In 1579, it was considerably enlarged by the care of William prince of Orange. It is now very well fortified, and is naturally strong, as the adjacent country can very easily be laid under water. The city is square; and the streets are handsome, straight, and clean, with canals in the middle of them. It has five gates; four towards the land, and one towards the sea; but though the harbour is good, yet vessels of great burden cannot get into it until they are lightened, for want of water. The admiralty college of Friesland has its seat here. The manufactures are salt, bricks, and tiles, a considerable trade is also carried on in all sorts of linen cloth, and the adjacent country yields abundance of corn and good pastures.

HARLOCH, or **HARLEICH**, a town of Merionethshire, in North Wales, 223 miles from London, on the sea coast, near the north-west point of the county. It is naturally strong, a garrison being kept here for the security of the coast. Its castle lies now in ruins. The town, though a corporation and governed by a mayor, makes but a very mean appearance. It has a market on Saturdays, and four fairs in the year.

HARLOT, a woman given to incontinency, or that makes a habit or a trade of prostituting her body.—The word is supposed to be used for the diminutive *whorelet*, a "little whore."—Others derive it from *Arlotta*, mistress to Robert duke of Normandy, and mother to William the Conqueror: Camden derives it from one *Arlotta*, concubine to William the Conqueror: Others from the Italian *Arlotta*, "a proud whore."

Harlots were tolerated amongst Jews, Greeks, and Romans. Fornication indeed was prohibited among the Jews, under severe penalties; but those they explained as extending only to women of their own nation. The public stews were therefore stocked with foreign prostitutes, who seem to have been taken under the protection of government. Hence appears the reason why the word *strange woman* is often found to signify a harlot. Prostitutes at first wore veils or masks; but by and by their modesty was entirely put to flight, and they went abroad bare-faced. At Athens the prostitutes were generally strangers; and such as debauched an Athenian female were liable to a penalty. To frequent the public stews was not held disgraceful! The wisest of the Heathen sages allowed it! Solon permitted common whores to go publicly to the young men who had engaged them, and encouraged the youth of A-

thens to gratify their lust with these, rather than seduce and debauch the wives or daughters of citizens. Cato the censor was of the same sentiments; and Cicero challenges all persons to name a time when men were either reproved for this practice, or not countenanced in it. Amongst the Jews, the harlots used to ply in the high-ways and streets of cities; at Athens they frequented the *ceramicus*, *sciros*, and the old forum.—In some places they were distinguished by their dress from other women. Corinth was a remarkable nursery of harlots, and gave birth to the noted *Lais*. Their accomplishments were oftentimes great, in all the polite and elegant parts of female education, viz. philosophy, dancing, singing, rhetoric, &c. *Aspasia*, the mistress of *Pericles*, was admired by *Socrates* for her learning.—The more accomplished prostitutes frequently amassed large fortunes: a remarkable instance of which we have in *Phryne*, who offered to rebuild the walls of *Thebes*, when destroyed by *Alexander*, on condition that they would perpetuate her memory and profession by an inscription. Prostitutes at *Rome* were obliged to fix a bill over their doors, indicating their character and profession. It was also customary for them to change their name, after they had signified to the prætor their intention of leading such a dissolute life: this they did, because their trade was unbecoming their birth and condition; but they reassumed their family names when they quitted their infamous mode of living. Women whose grandfather, father, or husband, had been a Roman knight, were forbidden by the laws to make a public profession of lewdness.

HARMATTAN, the name of a remarkable periodical wind which blows from the interior parts of Africa towards the Atlantic ocean. Of this wind we have the following account in the *Phil. Trans.* vol. lxxi. furnished by Mr *Norris*, a gentleman who had frequent opportunities of observing its singular properties and effects.

On that part of the coast of Africa which lies between *Cape Verd* and *Cape Lopez*, an easterly wind prevails during the months of *December*, *January*, and *February*, which by the *Fantees*, a nation on the Gold coast, is called the *Harmattan*. *Cape Verd* is in 15° N. Lat. and *Cape Lopez* in 1° S. Lat.; and the coast between these two capes runs, in an oblique direction, nearly from W. S. W. to E. S. E. forming a range of upwards of 2100 miles. At the isles de *Los*, which are a little to the northward of *Sierra Leone*, and to the southward of *Cape Verd*, it blows from the E. S. E. on the Gold coast from the N. E. and at *Cape Lopez*, and the river *Gabon*, from the N. N. E. This wind is by the French and Portuguese, who frequent the Gold coast, called simply the north-east wind, the quarter from which it blows. The English, who sometimes borrow words and phrases from the *Fantee* language, which is less guttural and more harmonious than that of their neighbours, adopt the *Fantee* word *Harmattan*.

The *harmattan* comes on indiscriminately at any hour of the day, at any time of the tide, or at any period of the moon, and continues sometimes only a day or two, sometimes five or six days, and it has been known to last fifteen or sixteen days. There are generally three or four returns of it every season. It blows with a moderate force, not quite so strong as the sea-breeze

Harmattan. breeze (which every day sets in during the fair season from the W., W. S. W., and S. W.); but somewhat stronger than the land wind at night from the N. and N. N. W.

1. A fog or haze is one of the peculiarities which always accompanies the harmattan. The gloom occasioned by this fog is so great, as sometimes to make even near objects obscure. The English fort at Whydah stands about the midway between the French and Portuguese forts, and not quite a quarter of a mile from either, yet very often from thence neither of the other forts can be discovered. The sun, concealed the greatest part of the day, appears only a few hours about noon, and then of a mild red, exciting no painful sensation on the eye.

2. Extreme dryness makes another extraordinary property of this wind. No dew falls during the continuance of the harmattan; nor is there the least appearance of moisture in the atmosphere. Vegetables of every kind are very much injured; all tender plants, and most of the productions of the garden, are destroyed; the grass withers, and becomes dry like hay; the vigorous evergreens likewise feel its pernicious influence; the branches of the lemon, orange, and lime trees droop, the leaves become flaccid, wither, and if the harmattan continues to blow for 10 or 12 days, are so parched, as to be easily rubbed to dust between the fingers: the fruit of these trees, deprived of its nourishment, and stunted in its growth, only appears to ripen, for it becomes yellow and dry, without acquiring half the usual size. The natives take this opportunity of the extreme dryness of the grass and young trees to set fire to them, especially near their roads, not only to keep those roads open to travellers, but to destroy the shelter which long grass, and thickets of young trees, would afford to skulking parties of their enemies. A fire thus lighted flies with such rapidity, as to endanger those who travel: in that situation, a common method of escape is, on discovering a fire to windward, to set the grass on fire to leeward, and then follow your own fire. There are other extraordinary effects produced by the extreme dryness of the harmattan.

The parching effects of this wind are likewise evident on the external parts of the body. The eyes, nostrils, lips, and palate, are rendered dry and uneasy, and drink is often required, not so much to quench thirst, as to remove a painful aridity in the fauces. The lips and nose become sore, and even chapped; and though the air be cool, yet there is a troublesome sensation of prickling heat on the skin. If the harmattan continues four or five days, the scarf skin peels off, first from the hands and face, and afterwards from the other parts of the body if it continues a day or two longer. Mr Norris observed, that when sweat was excited by exercise on those parts which were covered by his clothes from the weather, it was peculiarly acrid, and tasted, on applying his tongue to his arm, something like spirits of hartshorn diluted with water.

3. Salubrity forms a third peculiarity of the harmattan. Though this wind is so very prejudicial to vegetable life, and occasions such disagreeable parching effects on the human species, yet it is highly conducive to health. Those labouring under fluxes and intermit-

ting fevers generally recover in an harmattan. Those weakened by fevers, and sinking under evacuations for the cure of them, particularly bleeding, which is often injudiciously repeated, have their lives saved, and vigour restored, in spite of the doctor. It stops the progress of epidemics; the smallpox, remittent fevers, &c. not only disappear, but those labouring under these diseases, when an harmattan comes on, are almost certain of a speedy recovery. Infection appears not then to be easily communicated even by art. In the year 1770, there were on board the Unity, at Whydah, above 300 slaves; the smallpox broke out among them, and it was determined to inoculate; those who were inoculated before the harmattan came on, got very well through the disease. About 70 were inoculated a day or two after the harmattan set in, but no one of them had either sickness or eruption. It was imagined that the infection was effectually dispersed, and the ship clear of the disorder; but in a very few weeks it began to appear among those seventy. About 50 of them were inoculated the second time; the others had the disease in a natural way: an harmattan came on, and they all recovered, excepting one girl, who had an ugly ulcer on the inoculated part, and died some time afterwards of a locked jaw.

This account differs remarkably from that given by Dr Lind, who calls the harmattan a malignant and fatal wind: (See his *Diseases of Hot Climates*). As to the nature of the soil over which it blows, it appears that, excepting a few rivers and some lakes, the country about and beyond Whydah is covered for 400 miles back with verdure, open plains of grass, clumps of trees, and some woods of no considerable extent. The surface is sandy, and below that a rich reddish earth. It rises with a gentle ascent for 150 miles from the sea, before there is the appearance of a hill, without affording a stone of the size of a walnut. Beyond these hills there is no account of any great ranges of mountains.

HARMODIUS, a friend of Aristogiton, who delivered his country from the tyranny of the Pisistratidæ. (See **ARISTOGITON**). The Athenians, to reward the patriotism of these illustrious citizens, made a law that no one should ever after bear the name of Aristogiton or Harmodius.

HARMONIA, in fabulous history, the wife of Cadmus, both of whom were turned into serpents. See **CADMUS**.

Though many of the ancient authors make Harmonia a princess of divine origin, there is a passage in Athenæus from Euhemerus, the Vanini of his time, which tells us, that she was by profession a player on the flute, and in the service of the prince of Zidon previous to her departure with Cadmus. This circumstance, however, might encourage the belief, that as Cadmus brought letters into Greece, his wife brought *harmony* thither; as the word *harmonia*, has been said to have no other derivation than from her name: which makes it very difficult to ascertain the sense in which the Greeks made use of it in their music*; for it has no roots by which it can be decomposed, in order to deduce from them its etymology. The common account of the word, however, that is given by lexicographers, and generally adopted by the

* See *Harmony*.

Harmonia the learned, does not confirm this opinion. It is generally derived from *ἁρμονία*, and this from the old verb *ἁρμόω*, *Apw, apto, to fit or join.*

Harmonica. **HARMONIC.** As an adjective it signifies in general any thing belonging to harmony; though in our language the adjective is more properly written *harmonic*. In this case it may be applied to the *harmonic* divisions or a monochord; or, in a word, to consonances in general. As a substantive neuter, it imports all the concomitant or accessory sounds which, upon the principles resulting from the experiments made on sonorous bodies, attend any given sound whatever, and render it appetible. Thus all the aliquot parts of a musical string produce *harmonic* sounds, or *harmonics*.

HARMONICA. This word, when originally appropriated by Dr Franklin to that peculiar form or mode of musical glasses, which he himself, after a number of happy experiments, had constituted, was written *Armonica*. In this place, however, we have ventured to restore it to its native plenitude of sound, as we have no antipathy against the moderate use of aspirations. It is derived from the Greek word *ἁρμονία*. The radical word is *ἁρμόω*, *to suit or fit one thing to another.* By the word *ἁρμονία* the Greeks expressed *aptitudes of various kinds*; and from the use which they made of that expression, we have reason to conclude, that it was intended to import the highest degree of refinement and delicacy in those relations which it was meant to signify. Relations or aptitudes of sound, in particular, were understood by it; and in this view, Dr Franklin could not have selected a name more expressive of its nature and genius, for the instrument which we are now to describe; as, perhaps, no musical tones can possibly be finer, nor consequently susceptible of juster concords, than those which it produces.

In an old English book, whose title we cannot at present recollect, and in which a number of various amusements were described, we remember to have seen the elements or first approaches to music by glasses. The author enjoins his pupil to choose half a dozen of such as are used in drinking; to fill each of them with water in proportion to the gravity or acuteness of the sound which he intended it should produce; and having thus adjusted them one to another, he might entertain the company with a church-tune. These, perhaps were the rude and barbarous hints which Mr Puckeridge afterwards improved. But, for a farther account of him, of the state in which he left the instrument, and of the state to which it has afterwards been carried, we must refer our readers to the following extracts from Dr Franklin's letters, and from others who have written upon the same subject.

The Doctor, in his letter to Father Beccaria, has given a minute and elegant account of the Harmonica. Nor does it appear that his successors have either more sensibly improved, or more accurately delineated, that angelic instrument. The detail of his own improvements, therefore, shall be given in his own words.

"Perhaps (says he) it may be agreeable to you, as you live in a musical country, to have an account of the new instrument lately added here to the great number that charming science was possessed of before. As it is an instrument that seems peculiarly adapted

to Italian music, especially that of the soft and plaintive kind, I will endeavour to give you such a description of it, and of the manner of constructing it, that you or any of your friends may be enabled to imitate it, if you incline so to do, without being at the expence and trouble of the many experiments I have made in endeavouring to bring it to its present perfection.

"You have doubtless heard the sweet tone that is drawn from a drinking-glass, by pressing a wet finger round its brim. One Mr Puckeridge, a gentleman from Ireland, was the first who thought of playing tunes formed of these tones. He collected a number of glasses of different sizes; fixed them near each other on a table; and tuned them, by putting into them water, more or less as each note required. The tones were brought out by pressing his fingers round their brims. He was unfortunately burnt here, with his instrument, in a fire which consumed the house he lived in. Mr E. Delaval, a most ingenious member of our Royal Society, made one in imitation of it with a better choice and form of glasses, which was the first I saw or heard. Being charmed with the sweetness of its tones and the music he produced from it, I wished to see the glasses disposed in a more convenient form, and brought together in a narrower compass, so as to admit of a greater number of tones, and all within reach of hand to a person sitting before the instrument; which I accomplished, after various intermediate trials, and less commodious forms, both of glasses and construction, in the following manner.

"The glasses are blown as near as possible in the form of hemispheres, having each an open neck or socket in the middle. The thickness of the glass near the brim is about the tenth of an inch, or hardly quite so much, but thicker as it comes nearer the neck; which in the largest glasses is about an inch deep, and an inch and a half wide within; these dimensions lessening as the glasses themselves diminish in size, except that the neck of the smallest ought not to be shorter than half an inch. The largest glass is nine inches diameter, and the smallest three inches. Between these there are 23 different sizes, differing from each other a quarter of an inch in diameter. To make a single instrument there should be at least six glasses blown of each size; and out of this number one may probably pick 37 glasses (which are sufficient for three octaves with all the semitones) that will be each either the note one wants, or a little sharper than that note, and all fitting so well into each other as to taper pretty regularly from the largest to the smallest. It is true there are not 37 sizes; but it often happens that two of the same size differ a note or half a note in tone, by reason of a difference in thickness, and these may be placed one in the other without sensibly hurting the regularity of the taper form.

"The glasses being chosen, and every one marked with a diamond the note you intend it for, they are to be tuned by diminishing the thickness of those that are too sharp. This is done by grinding them round from the neck towards the brim, the breadth of one or two inches as may be required; often trying the glass by a well tuned harpsichord, comparing the note drawn from the glass by your finger with the note you want, as sounded by that string of the harp-

Harmonica-siobord. When you come near the matter, be careful to wipe the glass clean and dry before each trial, because the tone is something flatter when the glass is wet than it will be when dry;—and grinding a very little between each trial, you will thereby tune to great exactness. The more case is necessary in this, because if you go below your required tone, there is no sharpening it again but by grinding somewhat off the brim, which will afterwards require polishing, and thus increase the trouble.

“The glasses being thus tuned, you are to be provided with a case for them, and a spindle on which they are to be fixed. My case is about three feet long, eleven inches every way wide within at the biggest end, and five inches at the smallest end; for it tapers all the way, to adapt it better to the conical figure of the set of glasses. This case opens in the middle of its height, and the upper part turns up by hinges fixed behind. The spindle is of hard iron, lies horizontally from end to end of the box within, exactly in the middle, and is made to turn on brass gudgeons at each end. It is round, an inch diameter at the thickest end, and tapering to a quarter of an inch at the smallest.—A square shank comes from its upper end through the box, on which shank a wheel is fixed by a screw. This wheel serves as a fly to make the motion equable, when the spindle, with the glasses, is turned by the foot like a spinning-wheel. My wheel is of mahogany, 18 inches diameter, and pretty thick, so as to conceal near its circumference about 25lb. of lead.—An ivory pin is fixed in the face of this wheel, about four inches from the axis. Over the neck of this pin is put the loop of the string that comes up from the moveable step to give it motion. The case stands on a neat frame with four legs.

“To fix the glasses on the spindle, a cork is first to be fitted in each neck pretty tight, and projecting a little without the neck, that the neck of one may not touch the inside of another when put together, for that would make a jarring. These corks are to be perforated with holes of different diameters, so as to suit that part of the spindle on which they are to be fixed. When a glass is put on, by holding it stiffly between both hands, while another turns the spindle, it may be gradually brought to its place. But care must be taken that the hole be not too small, lest in forcing it up, the neck should split; nor too large, lest the glass, not being firmly fixed, should turn or move on the spindle, so as to touch or jar against its neighbouring glass. The glasses thus are placed one in another; the largest on the biggest end of the spindle, which is to the left hand: the neck of this glass is towards the wheel; and the next goes into it in the same position, only about an inch of its brim appearing beyond the brim of the first; thus proceeding, every glass when fixed shows about an inch of its brim (or three quarters of an inch, or half an inch, as they grow smaller) beyond the brim of the glass that contains it; and it is from these exposed parts of each glass that the tone is drawn, by laying a finger on one of them as the spindle and glasses turn round.

My largest glass is G a little below the reach of a common voice, and my highest G, including three complete octaves.—To distinguish the glasses more readily to the eye, I have painted the apparent parts of the

glasses within-side, every semitone white, and the other notes of the octave with the seven prismatic colours: viz. C, red; D, orange; E, yellow; F, green; G, blue; A, indigo; B, purple; and G, red again;—so that the glasses of the same colour (the white excepted) are always octaves to each other.

“This instrument is played upon by sitting before the middle of the set of glasses, as before the keys of a harpaichord, turning them with the foot, and wetting them now and then with a sponge and clean water. The fingers should be first a little soaked in water, and quite free from all greasiness; a little fine chalk upon them is sometimes useful, to make them catch the glass and bring out the tone more readily. Both hands are used, by which means different parts are played together. Observe, that the tones are best drawn out when the glasses turn from the ends of the fingers, not when they turn to them.

“The advantages of this instrument are, that its tones are incomparably sweet beyond those of any other; that they may be swelled and softened at pleasure by stronger or weaker pressures of the finger, and continued to any length; and that the instrument, being once well tuned, never again wants tuning.”

Such was the state in which this learned and ingenious author found, and such the perfection to which he carried that celestial instrument of which we now treat. We call it *celestial*; because, in comparison with any other instrument which we know, the sounds that it produces are indeed heavenly. Some of them, however, are still constructed in the same imperfect manner as the instrument of Mr Puckeridge. They are contained in an oblong chest; their positions are either exactly or nearly rectilinear; the artificial semitones by which the full notes are divided form another parallel line; but the distances between each of them are much greater than those between the notes of the natural scale, as they take their places, not directly opposite to the notes which they are intended to heighten or depress, but in a situation between the highest and lowest, to show, that in ascending they are sharps to the one, and in descending flats to the other. This structure, however, is doubly inconvenient; for it not only increases the labour and difficulty of the performer, but renders some musical operations impracticable, which upon the *Harmonica*, as constituted by Dr Franklin, may be executed with ease and pleasure. In this fabric, if properly formed and accurately tuned, the instrument is equally adapted to harmony and melody. But as no material structure could ever yet be brought to the perfection even of human ideas, this instrument still in some measure retains the perverse nature of its original stamina. Hence it is not without the utmost difficulty that the glasses can be tuned by grinding; and the least conceivable redundancy or defect renders the discord upon this instrument more conspicuous and intolerable than upon any other. Hence likewise that inexpressible delicacy to be observed in the manner of the friction by which the sound is produced: for if the touch be too gentle, it cannot extort the tone; and if too strong, besides the mellow and delicate sound which ought to be heard, we likewise perceive the finger jarring upon the glass, which, mingled with those softer sounds by which the senses had been soothed, gives a feeling similar to iron grating upon iron,

Harmonica. iron, but more disagreeable. In wind-instruments the operation of the tongue, in harpsicords the stroke of the quill, and on the violin the motion of the bow, gives the strong and sensible interruption of sound which may be called *articulation*, and which renders the rhythmus or measure of an air more perceptible; but upon the glasses, the touch of the finger is too soft to divide the notes with so much force; so that, unless the mind be steadily attentive, they seem to melt one into another, by which means the idea of rhythmus is almost lost. There is no way of performing a slur but by forbearing to stop the first sound, when that which is immediately subsequent commences. Thus, when the slur is of any length, and regularly descends or rises by the interval of a second, all the notes in the slur must be heard together, and produce no disagreeable dissonance; yet if it rises or descends by perfect chords, the effect is pleasing. The open shake, or trill, is another unhappy operation upon musical glasses; which can only be performed by the alternate pulsations of two continued sounds, differing from each other only by a note or semitone. But as these pulsations thus managed cannot be distinct, the result is far from being pleasant; nor is there any succedaneum for the close shake, which in the violin is performed by alternately depressing the string to the finger-board, and suffering it to rise without entirely removing the finger from it, and which, by giving the note that tremulous sound produced by the human voice affected with grief, is a grace peculiarly adapted to pathetic and plaintive airs.

We proceed, however, to a farther account of the same instrument, extracted from the Annual Register, vol. iv. p. 149.

“ Besides those tones, (says the author of that account) which every elastic string produces by vibration of all its parts, it is capable of another set of tones in which only a part of the string is supposed to vibrate. These sounds are produced by the lightest touches, either by air, as in Oswald's lyre, or by rubbing the bow in the softest manner on the string of a fiddle.

“ Analogous to these sounds are those produced by bells: in these last, besides those tones produced by their elliptical vibrations, there are a set of tones which may be brought by gently rubbing their edges, and in which the whole instrument does not appear to vibrate in all its parts as before.

“ Take, for instance, a bell finely polished at the edges; or, what will perhaps be more convenient, a drinking-glass: let the edges be as free from any thing oily as possible; then, by moistening the finger in water (I have found alum-water to be best), and rubbing it circularly round the edge of the glass, you will at length bring out the tone referred to.

“ This note is possessed of infinite sweetness; it has all the excellencies of the tone of a bell without its defects. It is loud, has a sufficient body, is capable of being swelled and continued at pleasure; and, besides, has naturally that vibratory softening which musicians endeavour to imitate by mixing with the note to be played a quarter-tone from below.

“ To vary these tones, nothing more is required than to procure several bells or glasses of different tones, tuned as nearly as possible, which may be done by thin-

ning the edges of either; or, for immediate satisfaction, the glasses may be tuned by pouring in water: the more water is poured in, the graver the tone will be.

“ Let us suppose then a double octave of those glasses, thus tuned, to be procured. Any common tune may be executed by the fingers rubbing upon each glass successively; and this I have frequently done without the least difficulty, only choosing those tunes which are slow and easy. Here then are numbers of delicate tones, with which musicians have been till very lately unacquainted; and the only defect is, that they cannot be made to follow each other with that celerity and ease which is requisite for melody. In order to remedy this, I took a large drinking-glass, and by means of a wheel and gut, as in the electrical machine, made it to turn upon its axis with a moderately quick but equable motion; then moistening the finger as before, nothing more was required than merely to touch the glass at the edge, without any other motion, in order to bring out the tone.

“ Instead of one glass only turning in this manner, if the whole number of glasses were so fixed as to keep continually turning by means of a wheel, it follows, that upon every touch of the finger a note would be expressed; and thus, by touching several glasses at once, a harmony of notes might be produced, as in a harpsichord.

“ As I write rather to excite than satisfy the curious, I shall not pretend to direct the various ways this number of glasses may be contrived to turn; it may be sufficient to say, that if the glasses are placed in the segment of a circle, and then a strap, as in a outler's wheel, be supposed to go round them all, the whole number will by this means be made to turn by means of a wheel.

“ Instead of the finger, I have applied moistened leather to the edge of the glass, in order to bring out the tone: but, for want of a proper elasticity, this did not succeed. I tried cork, and this answered every purpose of the finger; but made the tone much louder than the finger could do. Instead, therefore, of the finger, if a number of corks were so contrived as to fall with a proper degree of pressure on the edge of the glass, by means of keys like the jacks of an organ, it is evident, that in such a case a new and tolerably perfect instrument would be produced; not so loud indeed as some, but infinitely more melodious than any.

“ The mouths of the glasses or bells used in this experiment should not resemble the mouth of a trumpet, but should rather come forward with a perpendicular edge. The corks used in this case should be smooth, even free from those blemishes which are usually found in them, and at the same time the more elastic the better.”

In the two accounts here given seems to be comprehended every thing valuable which has been said upon the subject. It remains, however, our permanent opinion, that the form and structure designed and constituted by Dr Franklin is by much the most eligible; nor can we admit, that a cork, however successfully applied, will produce the same mellowness and equality of tone in general with the finger. It appears to us, that, by this kind of voluntary attrition, a note may be

Harmonica. sunk or swelled with much more art and propriety than by the substitution of any thing else extrinsic to the hand; and when chords are long protracted, that degree of friction, which renders every sound in the chord sensible to the ear, without harshness, must be the most agreeable. For this reason, likewise, we should recommend alum-water in preference to chalk.

From what has already been said, it will easily be perceived, that this instrument requires to be tuned with the nicest degree of delicacy which the laws of temperament will possibly admit. For these laws the reader will naturally have recourse to the article MUSIC*, in this Dictionary; where, from M. D'Alembert, is given a plain and satisfactory account, both of the method proposed by Rameau, and of that established in common practice, without anticipating the experience and taste of the reader, by dictating which of these plans is preferable. To those who have occasion to tune the instrument, it may likewise be useful to peruse the detached article TEMPERAMENT in this Work. Without recapitulating the different rules of alteration prescribed in these accounts, we shall presuppose the reader acquainted with them; and proceed to describe how, under their influence, the *Harmonica* may be tuned. But it is previously expedient to observe, that the same rules which conduct the process of tuning a harpsichord, will be equally effectual in tuning the *Harmonica*; with this only difference, that greater delicacy in adjusting the chords should, if practicable, be attempted.

* Chap. vii. art. 64.

There are different notes from whence the procedure of tuning may commence. *La* or *A*, which is the key that pretty nearly divides the harpsichord, is chosen by some; this *la* in common spinets is 24 natural keys from the bottom, and 13 from the top; and the *ut* above it; or second *C* upon the *G* cliffs, by others. This last we should rather advise, because we imagine those intervals which we have called *seconds major* to be more just through the whole octave, when the course of tuning is begun by a natural semitone. The initiate, therefore, may begin by tuning the second *ut* of his *Harmonica*, or *C* above the treble cliff, unison with its correspondent *C* upon the harpsichord or any other instrument in concert-pitch; then, descending to its octave below, adjust it with the *ut* above, till every pulsation if possible be lost, and the sounds rendered scarcely distinguishable when simultaneously heard. To the lowest note of this octave he must tune the *sol* or *G* immediately above it by a fifth, still observing the laws of temperament: To this *G*, the *re*, or *D* immediately above it, by the same chord: To the *re*, or *D* above, its octave below: To this, by a fifth, the *la* or *A* immediately above it: To *la*, the *mi* or *E* ascending in the same proportion: To *mi*, its octave below: To this, the *si* or *B* immediately above it by a fifth: To the first *ut*, or *C*, which was tuned, the *fa* or *F* immediately below by the same chord.

That the practitioner may be still more secure in the justice and propriety of his procedure, he may try the thirds of the notes already adjusted, and alter, as much as is consistent with the fifths and octaves, such among these thirds as may seem grating and disagreeable to his ear. Thus far having accomplished his operation, he may tune all the other natural notes whether above or below by octaves. His next concern is with the semi-

tones. And here it will be suggested by common sense, that as in all instruments with fixed scales, the sharp of a lower must likewise answer for the flat of a higher tone, the semitone ought as nearly as possible to divide the interval. He may begin with *la* or *A* sharp; which *la* in its natural state is a third minor beneath the *ut* or *C*, from whence he began in the natural scale. This semitone should correspond with the *F* natural immediately above by a fifth. To it may be tuned the *re* or *D* sharp immediately below by a similar chord: To *D* sharp, its octave above: To *si* or *B* natural, immediately above the *la* or *A* first mentioned, may be adjusted the *F* or *fa* sharp immediately above it: To this its octave below: To that octave, the *C* or *ut* sharp above by a fifth: To the *C* sharp, its octave below: To this, by a fifth, the *G* or *sol* sharp above. Between this *G* sharp and the *D* sharp immediately above it, the fifth will probably be too sharp; but if the others are justly tuned, that discord will not be extremely offensive; and it is a necessary consequence of temperament. The rest of the sharps and flats, like their naturals, whether ascending or descending, may be tuned by their octaves.

The notes, with their chords, may be expressed by letters and figures, thus; where, however, it must be observed, that the higher notes of any chord are marked with larger capitals. It should likewise be remarked, that the figures are not expressive of the different ratios which the notes bear to one another, considered with respect to their vibrations; but only significant of their nominal distances, according to the received denominations of the intervals. $\overset{1}{C}\overset{2}{C}\overset{3}{C}\overset{4}{D}\overset{5}{D}\overset{6}{D}\overset{7}{D}\overset{8}{A}$
 $\overset{1}{A}\overset{2}{E}\overset{3}{E}\overset{4}{E}\overset{5}{B}\overset{6}{C}\overset{7}{F}$. The sharps and flats thus, $\overset{1}{A}\overset{2}{F}\overset{3}{F}$,
 $\overset{1}{A}\overset{2}{D}\overset{3}{D}$, $\overset{1}{D}\overset{2}{D}\overset{3}{D}$, $\overset{1}{B}\overset{2}{F}\overset{3}{F}$, $\overset{1}{F}\overset{2}{F}\overset{3}{F}$. $\overset{1}{F}\overset{2}{C}\overset{3}{C}$, $\overset{1}{C}\overset{2}{C}\overset{3}{C}$.
 $\overset{1}{C}\overset{2}{G}\overset{3}{G}$. In running over the sharps and flats as the naturals, it will likewise be necessary to try the thirds, and to alter such as may offend the ear; which, if cautiously done, will not sensibly injure the other chords.—Though this article has been protracted to a length which we did not originally intend, we have however the satisfaction to find, that it comprehends every thing essential; so that any person who understands the nature of chords, and the practical principles of music as universally taught, may not only be able to tune his instrument, but to acquire its whole manœuvre, without the least assistance from a master. On Plate CCL. is represented an instrument of this kind.

Though this topic appeared in itself complete in the former edition of this extensive work, yet having since received from Dr Edmund Cullen of Dublin the following observations, and reflecting that men of musical talents have not only different tastes, but different powers of mechanical operation, we have thought it proper to submit to the choice of our readers, either Dr Franklin's form and arrangement of the glasses, or that which was adopted by Dr Cullen; but in either case, we would recommend it to the initiate in this instrument, to distinguish by colours, according to Dr Franklin, the notes and semitones.—We likewise cannot forbear to think, that the complete bass practicable on the harmonica, is by many degrees preferable to the chords with which Dr Cullen proposed to grace every

Harmonica. emphatic note, with which, from the structure and arrangement of his instrument, he was under the necessity of deluding instead of satisfying the ear, with the full effect of the regular procedure of the treble and bass upon the same instrument.

This instrument the doctor describes as consisting "of 35 glasses of different sizes, answering to so many distinct sounds, and ranged in the manner hereafter to be described. They are exactly of the form of a cocoa nut when the usual quantity of the top is cut off; or the sugar-bowls made of cocoa-nut shells so much in use will give a precise idea of their figure. They are blown with plain long stalks, which are fitted to wooden feet screwed on a board at proper distances, in such a manner that the circular tops of all may be in the same horizontal plane, at the distance of about an inch asunder. Of these 35, 10 only are allotted for half tones; there remain therefore 25 for the diatonic scale. The lowest note corresponds to G in the bass cleff; hence it extends upward to the octave above C in alt. For uniformity, take the glasses which are chosen gradually and regularly diminishing in size as they ascend in tone. This, however, is not absolutely necessary, as the tone of the glass does not entirely depend upon its size, but in a great measure upon the proportion of its different parts to one another: hence the glass corresponding to one note may be smaller than a glass corresponding to a note three or four times higher: however, where it is practicable, they should always be chosen gradually diminishing as they ascend, both on account of the elegance of appearance, and that an equality in point of loudness may be preserved; for, as every body knows, an instrument may be liable to great inequality in point of strength, though perfectly in tune. This must have a very bad effect; and therefore we find performers on the violin and other instruments of that kind very solicitous about the proportional thickness of their strings. The glasses being chosen in the best manner circumstances will permit, we proceed to arrange them. Here let me observe, that in general the diameter of the largest glass at its mouth is about seven inches, and its solid contents about five English pints, while the highest is of about one-fourth of an inch, and its contents about one-third of a gill: this, however, is arbitrary, and depends upon the pitch of the instrument. In arranging the glasses, we shall, to avoid confusion, take the diatonic scale first, and afterwards the half tones will be easily understood. The wooden feet before mentioned are to be screwed on a strong board of a proper size, and they are disposed at convenient intervals in rows perpendicular to the longest sides of the rectangular board on which they stand. In these feet the glasses are disposed in the following manner: Beginning with the lowest note G, we fix that on the foot which stands in the nearest angle of the board on the left hand, A in the next bottom in the same perpendicular line, B in the third: when we come to C, however, we do not place it in the same perpendicular line, but in the nearest bottom of the second perpendicular row to the left hand, D in the second of the same row, E in the third; F again in the nearest bottom of the third row, G in the second of the same row, A in the third; B again in the nearest bottom of the fourth row, C in the second of the same, and so on. By this contrivance it is easy to see an immense compass is obtain-

ed: so great a one indeed, that if the glasses were disposed according to the old method, regularly ascending in a line parallel to the front of the instrument, to take in the same compass, it must stretch to a considerable length, no less than a length equal to the sum of all the perpendiculars we before spoke of, which in ordinary size of the glasses would amount to upwards of 16 feet; the inconvenience of which it is unnecessary to dwell upon. As to the half tones, perhaps a more judicious and convenient arrangement may be thought of for them: but the present mode is far from inconvenient, except in some keys; and it is sufficiently commodious for performing such airs as are best suited to the nature and design of the instrument. After explaining the arrangement, we shall speak somewhat more exactly of them. E \flat on the first line of the treble stave stands in the fourth bottom of the first perpendicular row to the left hand; F \sharp on the first space stands in the fourth place of the second row; G \sharp on the second line of the treble stave stands in the fourth of the third row; C \sharp on the third space of the same stave stands in the same manner in the fourth row, and so on, ascending F \sharp in the fifth row, G \sharp in the sixth, A \sharp in the seventh, C \sharp in the eighth. In the ninth perpendicular row, that is, the last to the right hand in the diatonic scale, stands C alone; but immediately behind is placed B \flat of the middle line of the treble stave, and again behind it D \sharp of the fourth line of the treble stave, which finishes the whole. There is something singular, and perhaps whimsical, in the distribution of the half tones: but it is found sufficiently convenient; and if a better is thought of, it may easily be adopted. In the mean time I must observe, that two of them, viz. C \sharp and F \sharp , standing immediately behind the D and G respectively above them, are singularly well fitted for performing running passages either up or down in the key of G. Ex gr. let us suppose that we have that very common A, G, F \sharp , E, semiquavers. Here the performer touches A, which is in the first place of the sixth row, with his left hand, G with the fore-finger of his right, F \sharp with the middle, and E again with the left hand; in the same manner may E, D, C \sharp , and B, be played, or upwards by inverting the motion: Thus we can with the utmost ease run either up or down two very frequent passages, in a key which might naturally be supposed difficult upon this instrument, and that with any given rapidity. I wish as much could be said of all the other half tones, of which, by the bye, some are altogether wanting: it is obvious, however, that they may easily be added, if we can find convenient places; and I apprehend even that very practicable. Be that as it may, notwithstanding the seemingly inconvenient situation of some half tones, and the total want of others, pieces may be performed on this instrument of considerable rapidity. I myself, though very far from being an accomplished player, can with great ease go through all the parts of Fisher's celebrated rondeau; nay, I have heard the fifth concerto of Vivaldi played upon it with as much distinctness as upon a violin. The glasses are not necessarily chosen perfectly in tune, but are tuned by the help of a quantity of water. Here, however, two cautions are necessary: 1st, By no means to take a glass which is, when without water, flatter than the note you intend; as in that case you cannot remedy it, the water

Harmonica. making the tone still flatter : rather let it be somewhat sharper, and you may tune it to the utmost nicety by a little water. The second caution is, not to choose a glass which is very much sharper than the note required ; as in that case, so large a quantity of water will be required to tune it as will entirely smother the tone.

“ This instrument is to be played somewhat in the manner of the harmonica, viz. the fingers are to be well wetted ; and by the application of them to the side, assisted by a proper motion, the sound is produced. And here I would observe, that the proper motion is, to make the fingers follow the thumb, not the thumb follow the fingers, in going round the glass : it is necessary also to preserve the circular motion very exactly, as the least deviation from it produces the most horrible sound that can be conceived. It is likewise to be observed, that you must touch the smaller glasses upon the very top of the brim ; and for that purpose the palm of the hand must be nearly parallel to the top of the glass : but in coming to the larger glasses, it is absolutely necessary to make the fingers touch the side, not the top of the glass ; and the larger the glass, the more distant from the top must they be touched. Practice alone can determine this matter.

“ From this disposition of the glasses, it is easy to see that the perfect chord of C is always most completely in our power, namely, by using different fingers to the different notes at the same time : and although a full bass cannot be executed upon this instrument, we have always a great number of accompaniments which can easily be introduced ; more perhaps than upon any instrument, the organ and others of that species excepted. The thirds or fifths occasionally can be introduced ; and when done with taste and judgment, will scarcely yield to a middling bass. If to this is added the thrilling softness of the tones, inimitable by any other substance, it will readily appear to be an instrument more in the true style of music, of that music which the heart acknowledges, than any that either chance or ingenuity has hitherto produced. It is indeed incapable of that whimsical subdivision to which the taste of modern composers, that sworn enemy to harmony and real music, leads ; which serves no end but to exhibit the wonderful executions of a favourite performer, and to overwhelm his hearers with stupid admiration. This is not music ; and upon these occasions, though I acknowledge the difficulty of doing what I see done, I lament that the honest man has taken so much pains to so little purpose. Our instrument is not capable of this (at least not in so exquisite a degree as the harpsichord, violin, and a few others) : yet if the true and original intent of music is not to astonish but to please, if that instrument which most readily and pleasingly seizes the heart through the ears is the best, I have not a moment's hesitation in setting it down the first of all musical instruments. There is but one which will in any degree bear the comparison, or rather they are the same instrument, I mean Dr Franklin's harmonica : but I am inclined to think that the instrument we have been speaking of has some superiority over the harmonica. The first striking difference is in the impracticability of executing quick passages on the latter ; whereas it is in most cases extremely easy on the other. Again, the very long continued vibration of the glass, inevitably

must produce horrible discord, or at least confusion, except the piece played be so slow that the vibration of one glass be nearly over before the other is heard. Now, in our instrument, this may be remedied by laying pieces of sponge lightly between the glasses, so as to allow them only the proper extent of vibration. This, however, is an exceptionable method : and it is much better done by the touch of the performer's finger, which instantly stops the vibration ; and the use of this may be learned by a very little practice, the motion here being entirely voluntary : But in the harmonica, the motion being partly mechanical, v. g. the rotation of the glasses, this cannot be done ; and for the same reason, in the execution of the crescendo the harmonica is not so perfect as this instrument. Besides, the inconvenience of tuning the half tones, as sharps or flats, separately, is as great in the harmonica as in the harpsichord. This is a very great imperfection ; as half tones, being tuned at the medium, are false both as sharps and as flats. The learned Dr Smith says, there is no less than one-fifth of the interval difference between the sharp of one note and the flat of the next above ; and for this purpose proposes to have an harpsichord constructed with a stop, so as to direct the jacks to the sharps or flats according to the prevalence of either in the piece to be played : but in our instrument, from its very construction, this inconvenience is avoided. As to matters of convenience, the harmonica is exceedingly apt to be out of order ; the glasses frequently break, plainly on account of the great strain upon them where they join the spindle, and are thus with much difficulty renewed ; whereas with us the loss of a glass is nothing. Add to all this, that the harmonica, in point of original expence, is about five times as high as the other : although I apprehend it possesses no one advantage, except that the performer may sit at it ; whereas with our instrument it is convenient, if not necessary, to stand ; but he must be a lazy musician that gives himself much concern about that : And if he will sit at our instrument, he may, though at the expence of much ease in point of execution.

“ Let us now consider some objections that have been made to this instrument. One is, that necessity of standing, in order to do any thing capital upon it. But is not that the case in all instruments, except where the performer sits of necessity ? Did ever any one see Giardini or Fisher play a solo sitting ? But for the satisfaction of these torpid gentlemen, I can faithfully assure them, I knew a lady who performed on this instrument perfectly well, though she had lost the use of both her legs. A more serious and important objection lies both to this and the harmonica, viz. the want of a shake. How this is supplied upon the harmonica, I cannot say, as I never saw it even attempted : but on our instrument, although a very perfect shake can scarcely be produced, something so like it may be done as will fairly excuse the want ; and that is, by whirling the two stands round the note concerned with the shake with the utmost velocity, beginning the lower note a little sooner than the other. By this means, except in very large glasses where the vibrations are too distant in time, such an intermixture of the two sounds is produced, as extremely well imitates a fine shake, and the dexterous performer will make the beat in a turned shake with a spare finger. This operation requires some dexterity ;

Harmonica,
Harmony.

dexterity; but this is a charge common to all musical instruments; and I question not but that the Highland bagpipe itself requires some sort of skill.

“Upon the whole, I am clearly of opinion, that the harmonica, and more especially this instrument which has yet got no name, is the most exquisite and noble present that the lovers of true harmony have ever yet received; and it is with much astonishment I find this invaluable treasure almost entirely confined to Ireland, a country not very remarkable for musical taste or talents: But I hope soon to see this elegant species of music very generally known and practised over all Europe.”

HARMONY. The sense which the Greeks gave to this word in their music, is so much less easy to be determined, because, the word itself being originally a substantive proper, it has no radical words by which we might analyse it, to discover its etymology. In the ancient treatises which remain to us, *harmony* appears to be that department whose object is the agreeable succession of sounds, merely considered as high or low; in opposition to the two others called *rhythmica* and *metrica*, which have their principle in time and measure. This leaves our ideas concerning that aptitude of sound vague and undetermined; nor can we fix them without studying for that purpose all the rules of the art; and even after we have done so, it will be very difficult to distinguish harmony from melody, unless we add to the last the ideas of rhythmus and measure; without which, in reality, no melody can have a distinguishing character: whereas harmony is characterised by its own nature, independent of all other quantities except the chords or intervals which compose it.

It appears by a passage of Nicomachus, and by others, that they likewise gave the name of *harmony* to the chord of an octave, and to concerts of voices and instruments, which performed in the distance of an octave one from the other, and which is more commonly called *antiphone*.

Harmony, according to the moderns, is a succession of chords agreeable to the laws of modulation. For a long time this harmony had no other principle, but such rules as were almost arbitrary, or solely founded on the approbation of a practised ear, which decided concerning the agreeable or disagreeable succession of chords, and whose determinations were at last reduced to calculation. But Father Mersenne and M. Saveur having found that every sound, however simple in appearance, was always accompanied with other sounds less sensible, which constitute with itself a perfect chord-major; with this experiment M. Rameau set out, and upon it formed the basis of his harmonic system, which he has extended to a great many volumes, and which at last M. D'Alembert has taken the trouble of explaining to the public.

Signior Tartini, taking his route from an experiment which is newer and more delicate, yet no less certain, has reached conclusions similar enough to those of Rameau, by pursuing a path whose direction seems quite opposite. According to M. Rameau, the treble is generated by the bass; Signior Tartini makes the bass result from the treble. One deduces harmony from melody, and the other supposes quite the contrary. To determine from which of the two schools

the best performances are likely to proceed, no more is necessary than to investigate the end of the composer, and discover whether the air is made for the accompaniments, or the accompaniments for the air. At the word **SYSTEM** in Rousseau's Musical Dictionary, is given a delineation of that published by Signior Tartini. Here he continues to speak of M. Rameau, whom he has followed through this whole work, as the artist of greatest authority in the country where he writes.

He thinks himself obliged, however, to declare, That this system, however ingenious it may be, is far from being founded upon nature; an affirmation which he incessantly repeats: “That it is only established upon analogies and congruities, which a man of invention may overturn to-morrow, by substituting others more natural: that, in short, of the experiments from whence he deduces it, one is detected fallacious, and the other will not yield him the consequences which he would extort from it. In reality, when this author took it in his head to dignify with the title of *demonstration* the reasoning upon which he established his theory, every one turned the arrogant pretence into ridicule. The Academy of Sciences loudly disapproved a title so ill founded, and so gratuitously assumed; and M. Eative, of the Royal Society at Montpelier, has shown him, that even to begin with this proposition, That according to the law of nature, sounds are represented by their octaves, and that the octaves may be substituted for them, there was not any one thing demonstrated, or even firmly established, in his pretended demonstration.” He returns to his system.

“The mechanical principle of resonance presents us with nothing but independent and solitary chords; it neither prescribes nor establishes their succession. Yet a regular succession is necessary; a dictionary of selected words is not an oration, nor a collection of legitimate chords a piece of music: there must be a meaning, there must be connections in music as well as in language: it is necessary that what has preceded should transmit something of its nature to what is subsequent, so that all the parts conjoined may form a whole, and be stamped with the genuine character of unity.

“Now, the complex sensation which results from a perfect chord must be resolved into the simple sensation of each particular sound which composes it, and into the sensation of each particular interval which forms it, ascertained by comparison one with another. Beyond this there is nothing sensible in any chord; from whence it follows, that it is only by the relation between sounds, and by the analogy between intervals, that the connexion now in question can be established; and this is the genuine, the only source, from whence flow all the laws of harmony and modulation. If, then, the whole of harmony were only formed by a succession of perfect chords-major, it would be sufficient to proceed by intervals similar to those which compose such a chord; for then some one or more sounds of the preceding chord being necessarily protracted in that which is subsequent, all the chords would be found sufficiently connected; and the harmony would, at least in this sense, be one.

“But besides that these successions must exclude all melody by excluding the diatonic series which forms its

Harmony. foundation, it would not arrive at the real end of the art; because, as music is a system of meanings like a discourse, it ought, like a discourse, to have its periods, its phrases, its suspenses, its cadences, its punctuation of every kind; and because the uniformity of a harmonical procedure implies nothing of all this, diatonic procedures require that major and minor chords should be intermixed; and the necessity of dissonances has been felt in order to distinguish the phrases, and render the cadences sensible. Now, a connected series of perfect chords-major can neither be productive of perfect chords-minor nor of dissonances, nor can sensibly mark any musical phrase, and the punctuation must there be found entirely defective.

"M. Rameau being absolutely determined, in his system, to deduce from nature all the harmony practised among us, had recourse, for this effect, to another experiment of his own invention, of which I have formerly spoken, and which by a different arrangement is taken from the first. He pretended, that any simple sound whatever afforded in it multiplies a perfect minor or flat chord, of which it was the dominant or fifth, as it furnished a perfect chord-major by the vibration of its aliquot parts, of which it is the tonic or fundamental sound. He has affirmed as a certain fact, that a vocal string caused two others lower than itself to vibrate through their whole extent, yet without making them produce any sound, one to its twelfth major and the other to its seventeenth; and from this joined to the former fact, he has very ingeniously deduced not only the application of the minor mode and of dissonances in harmony, but the rules of harmonic phrases and of all modulation, such as they are found at the words *Chord, Accompaniment, Fundamental Bass, Cadence, Dissonance, Modulation.*

"But first (continues Rousseau), the experiment is false. It is discovered, that the strings tuned beneath the fundamental sound do not entirely vibrate when this fundamental sound is given; but that they are divided in such a manner as to return its unison alone, which of consequence can have no harmonics below. It is moreover discovered, that the property of strings in dividing themselves, is not peculiar to those which are tuned by a twelfth and seventeenth below the principal sound; but that oscillations are likewise produced in the lower strings by all its multiples. Whence it follows, that, the intervals of the twelfth and seventeenth below not being singular phenomena of their kind, nothing can be concluded in favour of the perfect minor chord which they represent.

"Though the truth of this experiment were granted, even this would by no means remove the difficulty. If, as M. Rameau alleges, all harmony is derived from the resonance of sonorous bodies, it cannot then be derived only from the vibrations of such bodies as do not resound. In reality, it is an extraordinary theory, to deduce from bodies that do not resound the principles of harmony; and it is a position in natural philosophy no less strange, that a sonorous body should vibrate without resounding, as if sound itself were any thing else but the air impelled by these vibrations. Moreover, sonorous bodies do not only produce, besides the principal sound, the other tones which with itself compose a perfect chord; but an infinite number of other sounds, formed by all the aliquot parts of the

bodies in vibration, which do not enter into that perfect harmony. Why then should the former sounds produce consonances, and why should the latter not produce them, since all of them equally result from nature?

"Every sound exhibits a chord truly perfect, since it is composed of all its harmonics, and since it is by them that it becomes a sound. Yet these harmonics are not heard, and nothing is distinguished but a simple sound, unless it be exceedingly strong; whence it follows, that the only good harmony is an unison; and that, as soon as the consonances can be distinguished, the natural proportion being altered, the harmony has lost its purity.

"That alteration is in this case produced two different ways. First, by causing certain harmonics to resound, and not the others, the proportions of force which ought to prevail in all of them is altered, for producing the sensation of a single sound; whence the unity of nature is destroyed. By doubling these harmonics, an effect is exhibited similar to that which would be produced by suppressing all the others; for in that case we cannot doubt, but that, along with the generating sound, the tones of the other harmonics which were permitted to sound would be heard: whereas, in leaving all of them to their natural operations, they destroy one another, and conspire together in forming and strengthening the simple sensation of the principal sound. It is the same effect which the full sound of a stop in the organ produces, when, by successively removing the stopper or register, the third and fifth are permitted to sound with the principal; for then that fifth and third, which remained absorbed in the other sounds, are separately and disagreeably distinguished by the ear.

"Moreover, the harmonics which we cause to sound have other harmonics pertaining to themselves; which cannot be such to the fundamental sound. It is by these additional harmonics that the sounds which produce them are distinguished with a more sensible degree of harshness; and these very harmonics which thus render the chord perceptible, do not enter into its harmony. This is the reason why the most perfect chords are naturally displeasing to ears whose relish for harmony is not sufficiently formed; and I have no hesitation, in thinking, that even the octave itself might be displeasing, if the mixture of male and female voices did not inure us to that interval from our infancy.

"With dissonance it is still worse, because, not only the harmonics of the sound by which the discord is produced, but even the sound itself, is excluded from the natural harmony of the fundamental; which is the cause why discord is always distinguished amongst all the other sounds in a manner shocking to the sense.

"Every key of an organ, with the stop fully opened, gives a perfect chord with its third major, which are not distinguished from the fundamental sound, if the hearer is not extremely attentive, and if he does not sound the whole stop in succession; but these harmonic sounds are never observed in the fundamental, but on account of the prodigious noise, and by such a situation of the registers as may cause the pipes which produce the fundamental sound to conceal by their force the other sounds which produce these harmonics. Now,

Harmony. no person observes, nor can observe, this continual proportion in a concert; since, by the manner of inverting the harmony, its greatest force must in every instant be transferred from one part to another; which is not practicable, and would destroy the whole melody.

“When we play upon the organ, every key in the bass causes to resound the perfect chord-major; but because that bass is not always fundamental, and because the music is often modulated in a perfect minor chord, this perfect chord-major is rarely struck with the right hand; so that we hear the third minor with the major, the fifth with the triton, the seventh redundant with the octave, and a thousand other cacophonies, which, however, do not much disgust our ears, because habit renders them tractable; but it is not to be imagined that an ear naturally just would prove so patient of discords, when first exposed to the test of this harmony.

“M. Rameau pretends, that trebles composed with a certain degree of simplicity naturally suggest their own basses; and that any man having a just, though unpractised ear, would spontaneously sing that bass. This is the prejudice of a musician, refuted by universal experience. Not only would he, who has never heard either bass or harmony, be of himself incapable of finding either the bass or the harmony of M. Rameau, but they would be displeasing to him if he heard them, and he would greatly prefer the simple unison.

“When we consider, that, of all the people upon earth, who have all of them some kind of music and melody, the Europeans are the only people who have a harmony consisting of chords, and who are pleased with this mixture of sounds: when we consider that the world has endured for so many ages, whilst, of all the nations which cultivated the fine arts, not one has found out this harmony; that not one animal, not one bird, not one being in nature, produces any other chord but the unison, nor any other music but melody; that the eastern languages, so sonorous, so musical; that the ears of the Greeks, so delicate, so sensible, practised and cultivated with so much art, have never conducted this people, luxurious and enamoured of pleasure as they were, towards this harmony which we imagined so natural; that without it their music produced such astonishing effects; that with it ours is so impotent; that, in short, it was reserved for the people of the north, whose gross and callous organs of sensation are more affected with the noise and clamour of voices, than with the sweetness of accents and the melody of inflections, to make this grand discovery, and to vend it as the essential principle upon which all the rules of the art were founded; when, in short, attention is paid to all these observations, it is very difficult not to suspect that all our harmony is nothing but a Gothic and barbarous invention, which would never have entered into our minds, had we been truly sensible to the genuine beauties of art, and of that music which is unquestionably natural.

“M. Rameau asserts, however, that harmony is the source of the most powerful charms in music. But this notion is contradictory both to reason and to matter of fact. To fact it is contradictory, because, since the invention of counter-point, all the wonderful effects of music have ceased, and it has lost its whole

force and energy. To which may be added, that such beauties as purely result from harmony are only perceived by the learned; that they affect none with transport but such as are deeply conversant in the art; whereas the real beauties of music, resulting from nature, ought to be, and certainly are, equally obvious to the adept and the novice. To reason it is contradictory; since harmony affords us no principle of imitation by which music, in forming images and expressing sentiments, can rise above its native excellence till it becomes in some measure dramatic or imitative, which is the highest pitch of elevation and energy to which the art can aspire; since all the pleasures which we can receive from the mere mechanical influence of sounds are extremely limited, and have very little power over the human heart.”

Thus far we have heard M. Rousseau, in his observations on harmony, with patience; and we readily grant, that the *system of harmony* by M. Rameau is neither demonstrated, nor capable of demonstration. But it will not follow, that any man of invention can so easily and so quickly subvert those aptitudes and analogies on which the system is founded. Every hypothesis is admitted to possess a degree of probability proportioned to the number of phenomena for which it offers a satisfactory solution. The first experiment of M. Rameau is, that every sonorous body, together with its principal sound and its octave, gives likewise its twelfth and seventeenth major above; which being approximated as much as possible, even to the chords immediately represented by them, return to the third, fifth, and octave, or, in other words, produce perfect harmony. This is what nature, when solicited, spontaneously gives; this is what the human ear, unprepared and uncultivated, imbibes with ineffable avidity and pleasure. Could any thing which claims a right to our attention and acceptance from nature, be impressed with more genuine or more legible signatures of her sanction than this? We do not contend for the truth of M. Rameau's second experiment. Nor is it necessary we should. The first, expanded and carried into all its consequences, resolves the phenomena of harmony in a manner sufficient to establish its authenticity and influence. The difficulties for which it affords no solution are too few and too trivial either to merit the regard of an artist, or a philosopher, as M. D'Alembert in his elements has clearly shown. The facts with which M. Rousseau confronts this principle, the armies of multiplied harmonics generated in *infinitum*, which he draws up in formidable array against it, only show the thin partitions which sometimes may divide philosophy from whim. For, as bodies are infinitely divisible, according to the philosophy now established, or as, according to every philosophy, they must be indefinitely divisible, each infinitesimal of any given mass, which are only harmonics to other principal sounds, must have fundamental tones and harmonics peculiar to themselves: so that, if the reasoning of Rousseau has any force against M. Rameau's experiment, the ear must be continually distracted with a chaos of inappretiable harmonics, and melody itself must be lost in the confusion. But the truth of the matter is, that by the wise institution of nature, there is such a conformity established between our senses and their proper objects, as must prevent all these disagree-

Harmony.

able effects. Rousseau and his opponent are agreed in this, that the harmonics conspire to form one predominant sound; and are not to be detected but by the nicest organs, applied with the deepest attention. It is equally obvious, that, in an artificial harmony, by a proper management of this wise precaution of nature, dissonances themselves may be either entirely concealed or considerably softened. So that, since by nature sonorous bodies in actual vibration are predisposed to exhibit perfect harmony; and since the human ear is, by the same wise regulation, fabricated in such a manner as to perceive it; the harmonical chaos of M. Rousseau may be left to operate on his own brain, where it will probably meet with the warmest reception it can expect to find*. Nor does it avail him to pretend, that before the harmonics can be distinguished, sonorous bodies must be impelled with a force which alters the chords, and destroys the purity of the harmony: for this position is equally false both in theory and practice;—in theory, because an impulse, however forcible, must proportionally operate on all the parts of any sonorous body, so far as it extends; in practice, because the human ear actually perceives the harmony to be pure. What effects his various manoeuvres upon the organ may have, we leave to such as have leisure and curiosity enough to try the experiments; but it is apprehended, that when tried, their results will leave the system of Rameau, particularly as remodelled by D'Alembert, in its full force.

* M. Rousseau was alive when this article was written.

Of all the whims and paradoxes maintained by this philosopher, none is more extravagant than his assertion, that every chord, except the simple unison, is displeasing to the human ear; nay, that we are only reconciled to octaves themselves by being inured to hear them from our infancy. Strange, that nature should have fixed this invariable proportion between male and female voices, whilst at the same time she inspired the hearers with such violent prepossessions against it as were invincible but by long and confirmed habit! The translator of *D'Alembert's Elements*, as given under the article MUSIC in this Dictionary, has been at peculiar pains to investigate his earliest recollections upon this subject; and has had such opportunities, both of attending to his original perceptions, and of recognising the fidelity of his memory, as are not common. He can remember, even from a period of early childhood, to have been pleased with the simplest kinds of artificial harmony; to have distinguished the harmonics of sonorous bodies with delight; and to have been struck with horror at the sound of such bodies as, by their structure, or by the cohesion of their parts, exhibited these harmonics false. This is the chief, if not the only cause, of the tremendous and disagreeable sensation which we feel from the sound of the Chinese ghong. The same horrible cacophony is frequently, in some degree, produced by a drum unequally braced: from this sound the translator often remembers to have started and screamed, when carried through the streets of the town in which he was born in the arms of his nursery-maid; and as he is conscious, that the acoustic organs of many are as exquisite as his own, he cannot doubt but they may have had the same sensations, though perhaps they do not recollect the facts. So early and so nicely may the sensations of harmony and discord be distinguished. But

after all, it seems that harmony is no more than a modern invention, and even at this late period only known to the Europeans. We should, however, be glad to know, from what oracle our philosopher learned that harmony was not known to antiquity. From what remains of their works, no proof of his position can be derived; and we have at least mentioned one probability against it in our notes to the Preliminary Discourse to the article MUSIC, (see note B). But though Rousseau's mighty objections were granted, that harmony can only be endured by such ears as are habitually formed and cultivated; that the period of its prevalence has been short, and the extent of its empire limited to Europe; still his conclusion, that it is a Gothic and barbarous invention, is not fairly deducible even from these premises. Must we affirm, that epic poetry has no foundation in nature, because, during the long interval which happened from the beginning of the world to the destruction of Troy, no epic poem seems to have appeared? Or because a natural and mellifluous versification is less relished by an unpolished taste, than the uncouth rhymes of a common ballad, shall we infer, that the power of numbers is merely supposititious and arbitrary? On the contrary, we will venture to affirm, that though harmony cannot, as Rameau supposes, be mathematically demonstrated from the nature and vibrations of sonorous bodies; yet the idea of its constituent parts, and of their coexistence, is no less established, no less precise and definite, than any mode or property of space or quantity to be investigated by geometrical researches or algebraical calculations. It is certain, that the mimetic or imitative power of music chiefly consists in melody; but from this truth, however evident, it cannot be fairly deduced that harmony is absolutely unsusceptible of imitation. Perhaps every musical sound, even to the most simple, and all modulations of sound, are more or less remotely connected with some sentiment or passion of the human heart. We know, that there are instinctive expressions of pain or pleasure in their various modes and degrees, which, when uttered by any sensitive, and perceived by any conscious being, excite in the mind of the percipient a feeling sympathetic with that by which they are prompted. We likewise know from experience, that all artificial sounds modulated in the same manner, have similar, though not equal, effects. We have seen that, in order to render harmony compatible with itself, the melody of each part must be congenial; and, for that reason, one kindred melody results from the whole. So far, therefore, as any composer has it in his power to render the general melody homogeneous, so far the imitation may be preserved, and even heightened: for such objects as are majestic and august, or the feelings which they excite, are more aptly expressed by a composition of kindred sounds, than by any simple tone whatever. Those who suppose the mimetic powers of music to be consummated in the imitation of mere unmeaning sounds or degrees of motion, must entertain limited and unworthy ideas of its province. It is naturally a representative almost of every sentiment or affection of the soul; and, when this end is gained, the art must have reached its highest perfection, and produced its noblest effects. But these effects, however sensible among the ancients, may in us be superseded by other causes which remain yet unexplored.

Harmony.

Harmony
||
Harness

explored. Theatrical performances are likewise, by them, said to have produced the most wonderful effects; yet these we do not recognise amongst ourselves, though we have dramatic entertainments perhaps not inferior to theirs.

Rousseau proceeds to tell us, that among the ancients the *enharmonic* species of music was sometimes called *harmony*.

Direct HARMONY, is that in which the bass is fundamental, and in which the upper parts preserve among themselves, and with that fundamental bass, the natural and original order which ought to subsist in each of the chords that compose this harmony.

Inverted HARMONY, is that in which the fundamental or generating sound is placed in some of the upper parts, and when some other sound of the chord is transferred to the bass beneath the others.

HARMONY of the Spheres, or *Celestial Harmony*, a sort of music much talked of by many of the ancient philosophers and fathers, supposed to be produced by the sweetly tuned motions of the stars and planets. This harmony they attributed to the various proportionate impressions of the heavenly globes upon one another, acting at proper intervals. It is impossible, according to them, that such prodigious large bodies, moving with so much rapidity, should be silent: on the contrary, the atmosphere, continually impelled by them, must yield a set of sounds proportionate to the impression it receives; consequently, as they do not all run the same circuit, nor with one and the same velocity, the different tones arising from the diversity of motions, directed by the hand of the Almighty, must form an admirable symphony or concert.

They therefore supposed, that the moon, as being the lowest of the planets, corresponded to *mi*; Mercury to *fa*; Venus to *sol*; the Sun to *la*; Mars, to *si*; Jupiter to *ut*; Saturn to *re*; and the orb of the fixed stars, as being the highest of all, to *mi*, or the octave.

HARMOSTES, or *HARMOSTA*, in antiquity, a sort of magistrate among the Spartans, whereof there were several, whose business was to look to the building of citadels, and repairing the forts and fortifications of the cities.—The word is ἀρμοστής, formed of ἀρμολογία, *arholo, concino*, "I adapt, concert," &c.

HARMOSYNIANS, ἀρμωσύνιοι, in antiquity, were magistrates among the Spartans, who, after the death of Lycurgus, were appointed to enforce the observance of that law of the Spartan legislator which required married women to wear a veil when they appeared in the streets, whereby they were distinguished from single females, who were allowed to appear abroad with their faces uncovered.

HARNESS, a complete armour, or the whole equipage and accoutrements of a cavalier heavily armed; as casque, cuirass, &c. The word is formed of the French *harnois*; which some derive from the Greek ἀρνίον, "a lamb's skin," because they anciently covered themselves therewith. Du Cange observes, that the word *harnesium* is used in the corrupt Latin in the same sense, and that it comes from the High Dutch *harnas* or *harnisch*. Others derive it from the Italian *arnese*; others from the Celtic *harnes*, "a cuirass."

Under King Richard II. it was expressly forbidden all men to ride in harness with lancegays. *Vide* stat. 7.

Richard II. cap. 13. In the statute 2 Henry VI. cap. 14. harness seems to include all kinds of furniture for offence as well as defence, both of men and horse; as swords, buckles for belts, girdles, &c.

HARNISS is also used for the furniture put on a horse to draw in a coach or waggon, or other carriage; such as collars, leathers, traces, &c.

HARO, a small town of Spain in Old Castile, on the Ebro, surrounded with walls. W. Long. 2 23. N. Lat. 42. 40.

HARO, *Harou*, or *Harol*, in the Norman customs.—*Clamour de haro* is a cry or formula of invoking the assistance of justice against the violence of some offender, who upon hearing the word *haro* is obliged to desist, on pain of being severely punished for his outrage, and to go with the party before the judge.

The word is commonly derived of *ha* and *roul*, as being supposed an invocation of the sovereign power, to assist the weak against the strong, on occasion of Raoul first duke of Normandy, about the year 912, who rendered himself venerable to his subjects by the severity of his justice; so that they called on him even after his death when they suffered any oppression. Some derive it from Harola king of Denmark, who in the year 826 was made grand conservator of justice at Mentz. Others from the Danish *aa rau*, q. d. "help me;" a cry raised by the Normans in flying from a king of Denmark named Roux, who made himself duke of Normandy. The letters of the French chancery have usually this clause, *Nonobstant clamour de haro*, &c.

The haro had anciently such vast power, that a poor man of the city of Caen named Asselin, in virtue hereof, arrested the corpse of William the Conqueror, in the middle of the funeral procession, till such time as his son Henry had paid the value of the land in question, which was that on which the chapel was built in which he was interred.

HAROLD, the name of two English kings. See ENGLAND, N^o 77, 83.

HARONIA, a town of Turkey, in the Arabian Irak, 45 miles north of Bagdad.

HAROUÉ, a town of France, in the department of Meurthe, 12½ miles south-west of Luneville.

HARP, a musical instrument of the stringed kind, of a triangular figure, and held upright between the legs of the performer.

Papias, and Du Cange after him, will have the harp to have taken its name from the Arpii, a people of Italy, who were supposed the first that invented it; and from whom, they say, it was borrowed by other nations. Menage, &c. derive the word from the Latin *harpa*, and that from the German *herp* or *harp*. Others bring it from the Latin *carpo*, because touched or thrummed with the fingers. Dr Hickes derives it from *harpa* or *hearpa*, which signify the same thing; the first in the language of the Cimbri, the second in that of the Anglo-Saxons. The English priest who wrote the life of St Dunstan, and who lived with him in the tenth century, says, cap. ii. n. 12. *Sumpsit secum ex more citharam suam, quam paterna lingua hearpam vocamus*; which intimates the word to be Anglo-Saxon.

The harp was the favourite musical instrument of the Britons and other northern nations in the middle ages; as is evident from their laws, and from every

Harness
||
Harp.

Harp.

passage in their history, in which there is the least allusion to music. By the laws of Wales, a harp was one of the three things that were necessary to constitute a gentleman, i. e. a freeman; and none could pretend to that character who had not one of these favourite instruments, or could not play upon it. By the same laws, to prevent slaves from pretending to be gentlemen, it was expressly forbidden to teach, or to permit, them to play upon the harp; and none but the king, the king's musicians, and gentlemen, were allowed to have harps in their possession. A gentleman's harp was not liable to be seized for debt; because the want of it would have degraded him from his rank, and reduced him to a slave. The harp was in no less estimation and universal use among the Saxons and Danes. Those who played upon this instrument were declared gentlemen by law; their persons were esteemed inviolable, and secured from injuries by very severe penalties; they were readily admitted into the highest company; and treated with distinguished marks of respect wherever they appeared.

There is some diversity in the structure of harps. That called the *triple harp* has 97 strings or chords in three rows, extending from C in the tenor cliff to double G in alt, which make five octaves: the middle row is for the semitones, and the two outside rows are perfect unisons. On the bass side, which is played with the right hand, there are 36 strings: on the treble side, 26; and in the middle row, 35 strings. There are two rows of pins or screws on the right side, serving to keep the strings tight in their holes, which are fastened at the other end to three rows of pins on the upper side. The harp, within the last 40 years, has been in some degree improved by the addition of eight strings to the unison, viz. from E to double F in alt. This instrument is struck with the finger and thumb of both hands. Its music is much like that of the spinet, all its strings going from semitone to semitone; whence some call it an *inverted spinet*. It is capable of a much greater degree of perfection than the lute.

There are among us two sorts of this instrument, viz. the *Welsh harp*, being that just described; and the *Irish harp*. Plate CCL. N^o 1. represents the harp of Brian Boiomb, king of all Ireland, slain in battle with the Danes A. D. 1014, at Clontarf. His son Donagh having murdered his brother Teige, A. D. 1023, and being deposed by his nephew, retired to Rome, and carried with him the crown, harp, and other regalia of his father, which he presented to the Pope in order to obtain absolution. Adrian IV. surnamed Breakspear, alleged this circumstance as one of the principal titles he claimed to this kingdom in his bull transferring it to Henry II. These regalia were kept in the Vatican till the Pope sent the harp to Henry VIII. with the title of Defender of the Faith; but kept the crown, which was of massive gold. Henry gave the harp to the earl of Clanricard, in whose family it remained till the beginning of the 18th century, when it came by a lady of the De Burgh family into that of Mac Mahon of Clenagh in the county of Clare, after whose death it passed into the possession of Commissioner Mac Namara of Limerick. In 1782 it was presented to the right honourable William Conyngham, who deposited it in Trinity college library. It is 32 inches high, and of extraordinary good workmanship;

Harp.

the sounding-board is of oak, the arms of red sally; the extremity of the uppermost arm in part is capt with silver extremely well wrought and chiseled. It contains a large crystal set in silver, and under it was another stone now lost. The buttons or ornamental knobs at the sides of this arm are of silver. On the front arm are the arms chased in silver of the O'Brien family, the bloody hand supported by lions. On the side of the front arm within two circles are two Irish wolf dogs cut in the wood. The holes of the sounding board where the strings entered are neatly ornamented with escutcheons of brass carved and gilt; the larger sounding-holes have been ornamented, probably with silver, as they have been the object of theft. This harp has 28 keys, and as many string-holes, consequently there were as many strings. The foot piece or rest is broken off, and the parts round which it was joined are very rotten. The whole bears evidence of an expert artist.

King David is usually painted with a harp in his hands; but we have no testimony in all antiquity that the Hebrew harp, called *chinnor*, was any thing like ours. On a Hebrew medal of Simon Maccabæus we see two sorts of musical instruments; but they are both of them very different from our harp, and only consist of three or four strings. All authors agree, that our harp is very different from the lyra, cithara, or barbiton of the Romans. Fortunatus, lib. vii. carm. 8. witnesses, that it was an instrument of the barbarians:

*Romanusque lyra, plaudat tibi barbarus harpa,
Græcus Achillsacha, crotta Britannia canat.*

Of ancient harps, two are represented on the same plate.—N^o 2. is a *trigonum* or triangular harp. It is taken from an ancient painting in the museum of the king of Naples, in which it is placed on the shoulder of a little dancing Cupid, who supports the instrument with his left hand and plays upon it with his right. The trigonum is mentioned by Athenæus, lib. iv. and by Julius Pollux, lib. iv. cap. 9. According to Athenæus, Sophocles calls it a *Phrygian instrument*; and one of his dipnosophists tells us, that a certain musician, named *Alexander Alexandrinus*, was such an admirable performer upon it, and had given such proofs of his abilities at Rome, that he made the inhabitants *μυρομανεις*, "musically mad." N^o 3. and 4. are varieties of the same instrument. N^o 5. is the Theban harp according to a drawing made from an ancient painting in one of the sepulchral grottoes of the first kings of Thebes, and communicated by Mr Bruce to Dr Burney*. The performer is clad in a habit made like a shirt, such as the women still wear in Abyssinia, and the men in Nubia. It reaches down to his ancles; his feet are without sandals, and bare; his neck and arms are also bare; his loose white sleeves are gathered above his elbows; and his head is close shaved. His left hand seems employed in the upper part of the instrument among the notes in *alto*, as if in an arpeggio; while, stooping forwards he seems with his right hand to be beginning with the lowest string, and promising to ascend with the most rapid execution: this action, so obviously rendered by an indifferent artist, shows that it was a common one in his time; or, in other words, that great hands were then frequent; and consequently that music was well understood and diligently followed.

On this instrument Dr Burney makes the following observations:

Harp.

observations: "The number of strings, the size and form of this instrument, and the elegance of its ornaments, awaken reflections, which to indulge would lead us too far from our purpose, and indeed out of our depth. The mind is wholly lost in the immense antiquity of the painting in which it is represented. Indeed the time when it was executed is so remote, as to encourage a belief, that arts, after having been brought to great perfection, were again lost and again invented long after this period.—With respect to the number of strings upon this harp, if conjectures may be allowed concerning the method of tuning them, two might be offered to the reader's choice. The first idea that presented itself at the sight of 13 strings was, that they would furnish all the semitones to be found in modern instruments within the compass of an octave, as from C to c, D to d, or E to e. The second idea is more Grecian, and conformable to antiquity; which is, that if the longest string represented *prostambanomenos*, or D, the remaining 12 strings would supply all the tones, semitones and quarter-tones, of the diatonic, chromatic, and enharmonic genera of the ancients, within the compass of an octave: but for my part, I would rather incline to the first arrangement, as it is more natural and more conformable to the structure of our organs, than the second. For with respect to the genera of the Greeks, though no historic testimony can be produced concerning the invention of the diatonic and chromatic, yet ancient writers are unanimous in ascribing to Olympus the Phrygian the first use of the enharmonic: and though in the beginning the melody of this genus was so simple and natural as to resemble the wild notes and rude essays of a people not quite emerged from barbarism; yet in after-times it became overcharged with finical fopperies and fanciful beauties, arising from such minute divisions of the scale as had no other merit than the great difficulty of forming them. It seems a matter of great wonder, with such a model before their eyes as the Theban harp, that the form and manner of using such an instrument should not have been perpetuated by posterity; but that, many ages after, another of an inferior kind, with fewer strings, should take place of it. Yet if we consider how little we are acquainted with the use and even construction of the instruments which afforded the greatest delight to the Greeks and Romans, or even with others in common use in a neighbouring part of Europe, only a few centuries ago, our wonder will cease; especially if we reflect upon the ignorance and barbarism into which it is possible for an ingenious people to be plunged by the tyranny and devastation of a powerful and cruel invader.

Bell-HARP, a musical instrument of the string kind, thus called from the common players on it swinging it about, as a bell on its basis.

It is about three feet long; its strings, which are of no determinate number, are of brass or steel wire, fixed at one end, and stretched across the sound-board by screws fixed at the other. It takes in four octaves, according to the number of the strings, which are struck only with the thumbs, the right hand playing the treble and the left hand the bass: and in order to draw the sound the clearer, the thumbs are armed with a little wire pin. This may perhaps be the *lyra* or *cythara* of the ancients; but we find no mention

made of it under the name it now bears, which must be allowed to be modern.

HARP of Æolus. See ACOUSTICS, p. 149.

HARPAGINES, in antiquity, were hooks of iron, hanging on the top of a pole, which, being secured with chains to the masts of ships, and then let down with great velocity into the enemy's vessels, caught them up into the air. By way of defence against these machines, they covered their ships with hides, which broke and blunted the force of the iron. The harpagines, by the Greeks called *ἀγρῶνες*, owe their invention to Anacharsis the Scythian philosopher.

HARPAGIUS. See ARPAGIUS.

HARPALUS, a Greek astronomer, who flourished about 480 B. C. corrected the cycle of eight years invented by Cleostratus; and proposed a new one of nine years, in which he imagined the sun and moon returned to the same point. But Harpalus's cycle was afterwards altered by Meton, who added ten full years to it. See CHRONOLOGY, N^o 27.

HARPIES (ΑΡΠΥΙΑΙ, ΗΑΡΠΥΙΑΙ), in antiquity, a rapacious impure sort of monsters of the bird kind, mentioned among the poets. They are represented with wings, ears like bears, bodies like vultures, face-like women, and feet and hands hooked like the talons of birds of prey. ^{*Virg. Æn. iii.}

The ancients looked on the harpies as a sort of genii or demons. Some make them the daughters of Tellus and Oceanus, the *earth* and *ocean*; whence, says Servius, it is, that they inhabit an island, half on land and half in water. Valerius Flaccus makes them the daughters of Typhon.

There were three harpies, Aello, Ocypete, and Cæläno, which last Homer calls *Podarge*. Hesiod, in his Theogony, ver. 267. only reckons two, Aello and Ocypete, and makes them the daughters of Thaumias and Electra, affirming that they had wings, and went with the rapidity of the wind. Zephyrus begat of them Balius and Xanthus, Achilles's horses. Pherecydes relates, that the Boreades expelled them from the Ægean and Sicilian seas, and pursued them as far as the islands which he calls *Plotæ* and Homer *Calynæ*; and which have since been called the *Strophades*.

Vossius, De Idol. lib. iii. cap. 99. p. 63. thinks, that what the ancients have related of the harpies, agrees to no other birds so well as the bats found in the territories of Darien in South America. These animals kill not only birds, but dogs and cats, and prove very troublesome to men by their peckings. But the ancients, as the same Vossius observes, knew nothing of these birds. By the harpies, therefore, he thinks, they could mean nothing else but the winds; and that it was on this account they were made daughters of Electra, the daughter of Oceanus. Such is the opinion of the scholiasts of Apollonius, Hesiod, and Eustathius. Their names, Aello, Ocypete, Cæläno, are supposed to suggest a farther argument of this.

Mr Bryant supposes that the harpies were a college of priests in Bithynia, who, on account of their repeated acts of violence and cruelty, were driven out of the country: their temple was called *Arpi*, and the environs *Arpiæ*, whence the Grecians formed *Αρπυιαί*; and he observes farther, that *Harpya*, *Αρπυια*, was certainly of old the name of a place.

Harp

Harpies

Harping

Harpoon.

HARPING-IRON. See **HARPOON.**

HARPINGS, the fore-parts of the wales which encompass the bow of a ship, and are fastened to the stem, being thicker than the after part of the wales, in order to reinforce the ship in this place, where she sustains the greatest shock of resistance in plunging into the sea, or dividing it, under a great pressure of sail.

HARPOERATES, in *Mythology*, the son of Isis and Osiris. This is an Egyptian deity, whose distinguishing attribute is, that he is represented with his fingers applied to his mouth, denoting that he is the god of silence. The statue of this idol was fixed in the entrance of most of the Egyptian temples, and he was commonly exhibited under the figure of a young man naked, crowned with an Egyptian mitre, holding in one hand a cornucopia, and in the other the flower of lotus, and sometimes bearing a quiver.

HARPOCRATION, **VALERIUS**, a celebrated ancient rhetorician of Alexandria, who has left us an excellent *Lexicon upon the ten orators of Greece*. Aldus first published this lexicon in the Greek at Venice in 1603. Many learned men have laboured upon it; but the best edition was given by James Gronovius at Leyden in 1696.

HARPOON or **HARPING-IRON**, a spear or javelin used to strike the whales in the Greenland fishery.

The harpoon, which is sometimes called the *harping-iron*, is furnished with a long staff, having at one end a broad and flat triangular head, sharpened at both edges, so as to penetrate the whale with facility: to the head of this weapon is fastened a long cord, called the *whale-line*, which lies carefully coiled in the boat, in such a manner as to run out without being interrupted or entangled. See **WHALE-FISHERY**, **CETOLOGY Index**.

Gun-HARPOON, a kind of fire-arm for discharging harpoons at whales, and thereby killing them more easily and expeditiously than formerly when the harpoons were thrown by the hand. Though this method was projected a good many years ago, it has but lately come into use; and premiums have been annually offered by the society for encouraging arts, &c. to the persons who first struck a fish in this manner. In the Transactions of that Society for 1786, we have an account of the first fish struck in this manner in 1784. The gun was of the blunderbuss construction, loaded with four common tobacco pipes full of glazed powder; the fish was shot at the distance of ten fathoms, the harpoon going into her back up to the ring; and she was killed in about an hour. In 1785 three whales were killed in this manner; four in 1786, and three in 1787. Since that time the gun-harpoon has come more into use, and will probably soon supersede the other method entirely. In the Transactions of the Society for 1789, we have accounts of a number of whales killed in this manner. The instrument appears to be extremely useful in calm still weather, as the whale, though a timorous creature, will frequently allow a boat to approach it to the distance of 20, 15, or even 10 fathoms, all of which distances are within reach of the gun-harpoon, though not within the reach of that thrown by the hand. The greatest inconvenience was in case of rain or snow, by which the lock was apt to get wet. To remedy this, a case of leather was made to fit round the gun and over the lock, lined

with tin, and big enough to fire the gun when it was on. The fish struck with an harpoon discharged in this manner are soon killed, by reason of its penetrating their bodies to a great depth, not less than five or six feet, which no man's strength would be able to accomplish. In the volume just quoted, we have an account of one which was shot through the tail. The harpoon broke in the slit, but five fathoms of line went through the tail. The fish was killed in eight hours, which is perhaps the only instance of a fish struck in that part being caught. In another, the harpoon carried six feet of line into its body; the creature died in ten minutes. Others were killed in 15 minutes or half an hour, and one had a rib broken by the violence of the stroke. In the Transactions of the Society for 1790, there are other accounts similar to the foregoing, and all agreeing as to the great usefulness of the instrument both for striking the fish at a considerable distance, and for killing them in a very short time.

HARPSICORD, the most harmonious of all the musical instruments of the string kind. It is played on after the manner of the organ, and is furnished with a set, and sometimes with two sets of keys; the touching or striking of these keys moves a kind of little jacks, which also move a double row of chords or strings, of brass or iron, stretched over four bridges on the table of the instrument.

HARQUEBUSS, a piece of fire-arms, of the length of a musket, usually cocked with a wheel. It carried a ball that weighed one ounce seven-eighths.

There was also a larger sort, called the great harquebuss, used for the defence of strong places, which carried a ball of about three ounces and a half: but they are now but little used, except in some old castles, and by the French in some of their garrisons.

HARRIER, a kind of hound, endowed with an admirable gift of smelling, and very bold in the pursuit of his game. See **CANIS**.

HARRINGTON, **STR JOHN**, an ingenious English poet, was the son of John Harrington, Esq. who was committed to the Tower by Queen Mary for holding a correspondence with her sister Elizabeth; who, when she came to the crown, stood-godmother to this son. Before he was 30, he published a translation of Ariosto's Orlando Furioso, a work by which he was principally known; for though he afterwards published some epigrams, his talent did not seem to have lain that way. He was created knight of the Bath by James I.; and presented a MS. to Prince Henry, levelled chiefly at the married bishops. He is supposed to have died about the latter end of James's reign.

HARRINGTON, *James*, a most eminent English writer in the 17th century, bred at Oxford, travelled into Holland, France, Denmark, and Germany, and learned the languages of those countries. Upon his return to England, he was admitted one of the privy-chamber extraordinary to King Charles I. He served the king with great fidelity, and made use of his interest with his friends in parliament to procure matters to be accommodated with all parties. The king loved his company except when the conversation happened to turn upon commonwealths. He found means to see the king at St James's; and attended him on the scaffold,

Harpoon

Harrington.

Harrington, scaffold, where, or a little before, he received a token of his majesty's affection. After the death of King Charles, he wrote his *Oceana*; a kind of political romance, in imitation of Plato's Commonwealth, which he dedicated to Oliver Cromwell. It is said, that when Oliver perused it, he declared, that "the gentleman had wrote very well, but must not think to cheat him out of his power and authority; for that what he had won by the sword, he would not suffer himself to be scribbled out of. This work was attacked by several writers, against whom he defended it. Beside his writings to promote republican principles, he instituted likewise a nightly meeting of several ingenious men in the New Palace-Yard, Westminster; which club was called the *Rota*, and continued till the secluded members of parliament were restored by General Monk. In 1661, he was committed to the Tower for treasonable designs and practices; and Chancellor Hyde, at a conference with the lords and commons, charged him with being concerned in a plot. But a committee of lords and commons could make nothing of that plot. He was conveyed to St Nicholas's island, and from thence to Plymouth, where he fell into an uncommon disorder of the imagination. Having obtained his liberty by means of the earl of Bath, he was carried to London, and died in 1677. He published, besides the above works, several others, which were first collected by Toland, in one volume folio, in 1700: but a more complete edition was published in 1737, by the reverend Dr Birch.

HARRIOT, THOMAS, a celebrated algebraist, was born at Oxford in 1560, where he was also educated. In 1579 he completed his bachelor's degree; and, being already distinguished for his mathematical learning, was soon after recommended to Sir Walter Raleigh, as a proper person to instruct him in that science. He was accordingly received into the family of that gentleman; who, in 1585, sent him with the colony, under Sir Richard Granville, to Virginia; of which country, having remained there about a year, he afterwards published a topographical description. About the year 1588, Mr Harriot was introduced by his patron Sir Walter Raleigh, to Henry Percy earl of Northumberland, who allowed him a pension of 120*l.* per annum. He spent many years of his life in Sion college; where he died in July 1621, of a cancer in his hip, and was buried in the church of St Christopher, where a handsome monument was erected to his memory. Anthony Wood tells us, he was a deist, and that the divines looked upon his death as a judgment. Be his religious opinions what they might, he was doubtless one of the first mathematicians of the age in which he lived, and will always be remembered as the inventor of the present improved method of algebraical calculation. His improvements in algebra were adopted by Des Cartes, and for a considerable time imposed upon the French nation as his own invention; but the theft was at last detected, and exposed by Dr Wallis, in his history of Algebra, where the reader will find our author's invention accurately specified. His works are, 1. A brief and true report of the new-found land of Virginia; of the commodities there found, and to be raised, &c. 2. *Artis analyticae praxis ad aequationes algebraicas nova expe-*

dita, et generali methodo resolvendas à posthumis Thomae Harriotti, &c. 3. *Ephemeris chryometrica*. Manuscript, in the library of Sion college. He is said to have left several other manuscripts, which are probably lost.

Dr Zach, who fully established the truth of Des Cartes having pilfered from the *Artis analyticae praxis*, &c. of Harriot, and given it to the world as his own, speaks thus of our celebrated mathematician and algebraist: "It is remarkable, that the fame and the honour of this truly great man, were constantly attacked by the French mathematicians, who could not endure that Harriot should in any way diminish the fame of their Vieta and Des Cartes, especially the latter, who was openly accused of plagiarism from our author.

"Des Cartes published his Geometry six years after Harriot's work appeared, viz. in the year 1637. Sir Charles Cavendish, then ambassador at the French court, observed to the famous geometrician Roverval, that these improvements in analysis had been already made these six years in England; and shewed him afterwards *Harriot's Artis Analyticae Praxis*: which, as Roverval was looking over, at every page he cried out, yes! yes! he has seen it! Des Cartes had also been in England before Harriot's death, and had heard of his new improvements and inventions in analysis.

"I found likewise (says Dr Zach) among the papers of Harriot a large set of observations on the satellites of Jupiter, with drawings of them, their positions, and calculations of their revolutions and periods. His first observation of these discovered satellites, I find to be of January 16. 1610, and they go till February 26. 1612. Galileo pretends to have discovered them January 7. 1610; so that it is not improbable that Harriot was likewise the first discoverer of these attendants of Jupiter."

HARRIS, JAMES, Esq. an English gentleman of very uncommon parts and learning, was the son of James Harris, Esq. by a sister of Lord Shaftesbury author of *The Characteristics*. He was born in the Close at Salisbury 1709; and educated at the grammar-school there. In 1726, he was removed to Wadham-college in Oxford, but took no degree. He cultivated letters, however, most attentively; and also music, in the theory and practice of which he is said to have had few equals. He was member for Christchurch, Hants, which he represented in several successive parliaments. In 1753, he was appointed one of the lords commissioners of the admiralty, and soon after removed to the board of treasury. In 1774 he was made secretary and comptroller to the queen, which post he held until his death. He died Dec. 21. 1780, in his 72d year, after a long illness, which he bore with calmness and resignation.—He is the author of some valuable works. 1. *Three Treatises, concerning Art; Music, Painting, and Poetry; and Happiness*, 1745, 8vo. 2. *Hermes; or, A Philosophical Enquiry concerning Universal Grammar*. 3. *Philosophical Arrangements*. 4. *Philological Inquiries*, 1782, 2 vols 8vo, finished just before his death, and published since. These Inquiries show much ingenuity and learning; but being the amusement of his old age rather than an exertion of genius, they have not the philosophic tone of his former productions.

HARRIS, one of the Hebrides or Western Islands

Harrington,
Harriot.

Harriot,
Harris.

Harris,
Harrison.

of Scotland. It is about 25 miles in length, and from 6 to 8 in breadth. Upon the east side it is rocky; but on the west there are some tolerable farms, and the population in 1801 was estimated at nearly 3000. It has Lewis on the north, and North Uist on the south, from which it is separated by a channel of four miles in width, called the *Sound of Harris*. This channel is navigable for vessels of burden, but it requires a skilful pilot. It is the only passage between the Butt of the Lewis and Bara for vessels of burden passing to and from the west side of the Long Island. The sound is generally encumbered with rocks and islands, some of which are considerable, as Bernera, Pabbay, Ensay, Killegray. These, with Scalpay, Taransay, and Scarp, compose the inhabited islands on the coast of Harris. Some of them produce good crops of grain, and all of them good pasture. Harris and its islands sell from 400 to 500 tons of kelp annually; it abounds on the east side in excellent lochs or bays, and its shores on both sides form one continued fishery. The fish on this coast, and along the whole shores of the Long Island, are more numerous, and of larger dimensions, than those on the opposite continent; on which account, two royal fishing stations were begun in the reign of Charles I. one in Loch Maddie, and the other in the Sound of Harris.

HARRISON, WILLIAM, a writer much esteemed and patronised by the literati of his time, was fellow of New-college, Oxford, and had no other income than 40l. a-year as tutor to one of the duke of Queensberry's sons. In this employment he fortunately attracted the favour of Dr Swift, whose solicitations with Mr St John obtained for him the reputable employment of secretary to Lord Raby, ambassador at the Hague, and afterwards earl of Strafford. A letter of his whilst at Utrecht, dated Dec. 16. 1712, is printed in the Dean's works. Mr Harrison, who did not long enjoy his rising fortune, was dispatched to London with the Barrier treaty; and died Feb. 14. 1712-13. See the *Journal to Stella*, of that and the following day; where Dr Swift laments his loss with the most unaffected sincerity. Mr Tickel has mentioned him with respect in his *Prospect of Peace*; in *English Poets*, vol. xxvii. p. 113; and Dr Young in the beautiful close of an Epistle to Lord Lansdowne, vol. liii. p. 183. most pathetically bewails his loss. Dr Birch, who has given a curious note on Mr Harrison's Letter to Swift, has confounded him with *Thomas Harrison*, M. A. of Queen's-college. In Nichols's *Select Collection* are some pleasing specimens of his poetry; which, with Woodstock-Park in Dodsley's Collection, and an Ode to the duke of Marlborough, 1707, in *Duncombe's Horace*, are all the poetical writings that are known of this excellent young man; who figured both as an humorist and a politician in the fifth volume of the *Tatler*, of which (under the patronage of Bolingbroke, Henley, and Swift) he was professedly the editor. See the Supplement to Swift.—There was another *William Harrison*, author of *The Pilgrim*, or the happy Convert, a Pastoral Tragedy, 1709.

HARRISON, John, an ingenious mechanic, the celebrated inventor of the famous *time-keeper* for ascertaining the longitude at sea, and also of the compound, or, as it is commonly called, the *gridiron-pendulum*; was born at Foulby, in the parish of Wragby, near

Pontefract in Yorkshire, in 1693. The vigour of his natural abilities, if not even strengthened by the want of education, which confined his attention to few objects, at least amply compensated the deficiencies of it; as fully appeared from the astonishing progress he made in that branch of mechanics to which he devoted himself. His father was a carpenter, in which profession the son assisted; occasionally also, according to the miscellaneous practice of country artists, surveying land, and repairing clocks and watches. He was, from his early childhood, attached to any machinery moving by wheels, as appeared while he lay sick of the small-pox about the sixth year of his age, when he had a watch placed open upon his pillow to amuse himself by contemplating the movement. In 1700, he removed with his father to Barrow in Lincolnshire; where though his opportunities of acquiring knowledge were very few, he eagerly improved every incident from which he might collect information; frequently employing all or great part of his nights in writing or drawing: and he always acknowledged his obligations to a clergyman who came every Sunday to officiate in the neighbourhood, who lent him a MS. copy of Professor Saunderson's Lectures; which he carefully and neatly transcribed, with all the diagrams. His native genius exerted itself superior to these solitary disadvantages; for in the year 1726, he had constructed two clocks, mostly of wood, in which he applied the escapement and compound pendulum of his own invention: these surpassed every thing then made, scarcely erring a second in a month. In 1728, he came up to London with the drawings of a machine for determining the longitude at sea, in expectation of being enabled to execute one by the board of longitude. Upon application to Dr Halley, he referred him to Mr George Graham; who, discovering he had uncommon merit, advised him to make his machine before he applied to the board of longitude. He returned home to perform this task; and in 1735 came to London again with his first machine; with which he was sent to Lisbon the next year for a trial of its properties. In this short voyage, he corrected the dead reckoning about a degree and a half; a success that proved the means of his receiving both public and private encouragement. About the year 1739, he completed his second machine, of a construction much more simple than the former, and which answered much better; this, though not sent to sea, recommended Mr Harrison yet stronger to the patronage of his private friends and of the public. His third machine, which he produced in 1749, was still less complicated than the second, and superior in accuracy, as erring only three or four seconds in a week. This he conceived to be the *no plus ultra* of his attempts; but in an endeavour to improve pocket-watches, he found the principles he applied to surpass his expectations so much, as to encourage him to make his fourth time-keeper, which is in the form of a pocket watch, about six inches diameter. With this time-keeper his son made two voyages, the one to Jamaica, and the other to Barbadoes: in both which experiments it corrected the longitude within the nearest limits required by the act of the 12th of Queen Anne; and the inventor therefore, at different times, though not, without infinite trouble, received

Harrison.

Harrison,
Harrogate.

the proposed reward of 20,000l. These four machines were given up to the board of longitude. The three former were not of any use, as all the advantages gained by making them were comprehended in the last; they were worthy, however, of being carefully preserved as mechanical curiosities, in which might be traced the gradations of ingenuity executed with the most delicate workmanship; whereas they now lie totally neglected in the royal observatory at Greenwich. The fourth machine, emphatically distinguished by the name of *the time-keeper*, has been copied by the ingenious Mr Kendal; and that duplicate, during a three years circumnavigation of the globe in the southern hemisphere by Captain Cook, answered as well as the original. The latter part of Mr Harrison's life was employed in making a fifth improved time-keeper on the same principles with the preceding one; which, at the end of a ten weeks trial, in 1772, at the king's private observatory at Richmond, erred only $4\frac{1}{2}$ seconds. Within a few years of his death, his constitution visibly declined; and he had frequent fits of the gout, a disorder that never attacked him before his 77th year: he died at his house in Red-Lion square, in 1776, aged 83. The reclusive manner of his life in the unremitting pursuit of his favourite object, was by no means calculated to qualify him as a man of the world; and the many discouragements he encountered in soliciting the legal reward of his labours, still less disposed him to accommodate himself to the honours of mankind. In conversing on his profession, he was clear, distinct, and modest; yet, like many other mere mechanics, found a difficulty in delivering his meaning by writing; in which he adhered to a peculiar and uncouth phraseology. This was but too evident in his *Description concerning such mechanism as will afford a nice or true mensuration of time*, &c. 8vo, 1775; which his well-known mechanical talents will induce the public to account for from his unacquaintance with letters, from his advanced age, and attendant mental infirmities, among which may be reckoned his obstinate refusal to accept of any assistance whatever in this publication. This small work includes also an account of his new musical scale, or mechanical division of the octave, according to the proportion which the radius and diameter of a circle have respectively to the circumference. He had in his youth been the leader of a distinguished band of church-singers; had a very delicate ear for music; and his experiments on sound, with a most curious monochord of his own improvement, are reported to have been not less accurate than those he was engaged in for the mensuration of time.

HARROGATE, a village in the west riding of Yorkshire, in the parish of Knaresborough, remarkable for its medicinal springs. These are three in number, all different in their qualities, notwithstanding their contiguity. 1. The Tewet water or Sweet Spa, a vitriol spring, of a sort of milky taste, used in gravelly cases, was discovered by Mr Slingsby in 1638. 2. The stinking or sulphur spring, useful in dropsical, scorbutic, and gouty cases, rises in the town, and is received in four basons under four different buildings; at one it is drunk, at the others used for hot or cold baths. It is perfectly clear; but the taste and smell a composition of rotten eggs, sea-water, and sulphur, and extremely

VOL. X. Part I.

salt. Bathing is the most general method of using it. It is the strongest sulphur water in Great Britain; and from the superior strength of the impregnating sulphur, it does not lose the sulphureous smell even when exposed to a scalding and almost boiling heat; and in distilling it, when three pints had been taken off from a gallon of it, the last was as strong as the first, and stunk intolerably. It is discutient and attenuating; and a warm bath of it is of great benefit in pains and aches, strains and lameness, dissolving hard swellings, curing old ulcers and scrophulous complaints, and is a powerful cleanser of the stomach and bowels. 3. St Mungo's well is so called from Kentigern a Scotch saint, much honoured hereabouts, whom his tutor Servanus bishop of Orkney, out of affection for him, called *Mongah*, which in the Norish or Norway language signifies a dear friend.—The Harrogate season is from May to Michaelmas; and the company assemble and lodge in five or six large houses or inns on the heath, a mile from the village, each house having a long room and an ordinary: the best company used to lodge at Knaresborough, which is three miles off.

HARROW-ON-THE-HILL, a town of Middlesex, so called from its situation on the highest hill in the county, is 10 miles north-west of London. This parish is noted for a free school, founded in the reign of Queen Elizabeth. A silver arrow is shot for here once a-year, viz. August 4. by a select number of the scholars, who are dressed for the purpose in the habit of archers.

HARROW, an instrument in *Agriculture*. See *AGRICULTURE*, N^o 158.

HART, a stag, or male-deer, in the sixth year. See *CERVUS*, *MAMMALIA Index*.

HART-Beest, or Quanga. See *CATRA*, *MAMMALIA Index*.

HART'S HORNS, the horns of the common male deer.—The scrapings or raspings of the horn of this animal are medicinal, and used in decoctions, ptisans, &c.

Hartshorn jelly is nutritive and strengthening, and is sometimes given in diarrhoeas; but a decoction of burnt hartshorn in water is more frequently used for this purpose, and is called *hartshorn drink*.

The coal of hartshorn, by being calcined with a long continued and strong fire, is changed into a very white earth, called *hartshorn* calcined to whiteness. This earth is employed in medicine as an absorbent, and administered in dysenteries and labour pains, which are supposed to be caused by acrid and ill-digested matters. This earth levigated is the basis of Sydenham's white decoction, which is commonly prescribed in these diseases.

The salt of hartshorn is a great sudorific, and given in fevers with success; and hartshorn also yields, by distillation, a very penetrative volatile spirit.

HARTFORD, the capital of the county of the same name, signifying, as is commonly thought, the "ford of harts," stands on the river Lea, 21 miles from London; and is of considerable antiquity. Here the East-Saxon kings often kept their court; and here, in 1673, was held a synod. King Alfred built a castle here, by which the Danish vessels were destroyed, that came up from the Thames by its river as far as Ware, where the Danes had erected a fort, from which they

N a

Harrogate
Hartford.

Hartford. made frequent sallies to plunder and destroy the country. The present castle consists of a gate-house or lodge of brick, and a range of brick buildings, which seem of the time of James or Charles I. and also of a very ancient wall of rubble stone, with angular towers, supposed to have been standing ever since its first foundation. The manor of this town was all along the king's, of whom both the town and castle were formerly held *in capite*. The barons took the latter from King John, but Henry III. recovered it. Edward III. gave the town a charter, for markets on Thursday and Saturday, and in his grant of it to John of Gaunt it is called *The Honour of Hartford*. It sent members to parliament in the reign of Edward I. but after the 7th of Henry V. on the petition of the bailiff and burgesses to be exempted by reason of their poverty, that privilege was discontinued till the 22d of James I. Henry VI. who kept his Easter here in 1429, ordained by his charter, confirming their market, that no other should be kept on the same days, within seven miles, on pain of having the goods seized by the bailiffs of Hartford. This manor being then part of Queen Margaret's jointure, the courts were held in her name, and she appointed a horse fair to be kept in what part of the town the bailiff and constables thought fit. The standard of weights and measures was fixed here in the reign of Henry VII.; and Mary I. made this a corporation by the name of bailiffs and burgesses, of whom the latter were 16 by her charter. In the 25th and 35th of Elizabeth, Michaelmas-term was kept here, by reason of the plague at both times in London; and that queen, who sometimes resided in its castle, and declared the borough as parcel of her duchy of Lancaster, granted it a new charter, by the style of a bailiff, 11 capital burgesses, and 16 assistants, with a market on Saturday. James I. granted it a new charter, with the style of mayor, burgesses, and commonalty, to have 10 capital burgesses and 16 assistants, the mayor to be chosen out of the former by both of them; and a fair was then appointed here on May 12. Here was once a monastery, founded by a nephew of William the Conqueror; and here were formerly five churches, which are now reduced to two. In St Andrew's there is a seat not only for the mayor and aldermen, but another for the governors of Christ church hospital in London, who have erected a house in this town on account of its healthy air and dry situation, to receive such children as wanted either health or room in that hospital; and they have built a gallery in the church, wherein 200 of their children may be accommodated. The town is governed by a mayor, high-steward, who is generally a nobleman, a recorder, 9 aldermen, a town-clerk, chamberlain, 10 capital burgesses, and 16 assistants, and has 2 serjeants at mace. In 1811, the number of inhabitants was 3900. The chief commodities of its market are wheat, malt, and wool; and it is said to send 5000 quarters of malt to London weekly by the river Lea. Besides the above mentioned, here are two fairs on July 5. and November 8. and two others for cattle, viz. the Saturday fortnight before Easter, and its Midsummer fair is chiefly for horses. Here is a handsome free grammar-school, besides 3 charity schools; but the splendour of the place is much diminished since the north road from London was turned through Ware. The county gaol, however, is still kept in the town,

and the gaol-delivery in the castle. It gives the title of earl to the noble family of Seymour-Conway. **Hartford**

HARTFORDSHIRE, a county of England, deriving its name from Hartford the capital; and that from the harts with which it anciently abounded, being then overrun with woods. It is bounded on the east by Essex, on the west by Bedfordshire and Buckinghamshire, on the south by Middlesex, and on the north by Cambridgeshire. This county is much indented by those that surround it: the longest part is about 35 miles, and the broadest about 27; and the circumference is 190, containing about 451,000 acres. It is divided into eight hundreds, which contain 19 market towns, 54 vicarages, 120 parishes, and near 950 villages, and in 1811, contained 111,654 inhabitants. It sends six members to parliament, two knights for the shire, with two burgesses for St Alban's, and as many for Hartford. Before the reign of Queen Elizabeth, one sheriff served both for this shire and Essex; but in the ninth year of her reign, it had one allotted for itself. With regard to ecclesiastical jurisdiction, it belongs partly to the diocese of Lincoln, and partly to that of London. Though the soil in general, especially in the Chiltern and southern parts, is but very indifferent, and much inferior to that of the neighbouring counties; yet the air is so much superior, that lands in this shire generally sell at three or four years purchase more than in many others on that account. But it must be owned, that the soil of Hertfordshire has been much improved of late, by draining, sowing grass seeds, and other methods. There are few or no manufactures in the county; but its markets are much frequented, in consequence of its being near London, for malt and all sorts of grain. See **HERTFORDSHIRE**, SUPPLEMENT.

HARTLAND, a town in Devonshire, near the Bristol channel, with a market on Saturdays, much frequented by the people of Cornwall, who come hither in boats. It gives its name to a point, called *Hartland Point*, at the entrance of Bristol channel. W. Long. 4. 45. N. Lat. 51. 9.

HARTLEPOOL, a sea-port town in the county of Durham. It is commodiously seated on a promontory, and is almost encompassed by the sea. It is an ancient corporation, governed by a mayor and aldermen, with other subordinate officers. It is a pretty large, but poor place, and had 1047 inhabitants in 1811. It depends chiefly on the fishing trade; and its harbour is much frequented by colliers passing to and from Newcastle. W. Long. 1. 5. N. Lat. 54. 48.

HARTLEY, a town of Northumberland, on the coast, situated north-west of Tyne-mouth, where Lord Delaval has constructed a pretty haven, whence coals are shipped for London. Here are large salt works and copperas works, and likewise considerable glass works; and there is here a canal cut through a solid rock to the harbour, 52 feet deep, 30 broad, and 900 long. The inhabitants in 1811 were estimated at 1872. W. Long. 1. 3. N. Lat. 55. 6.

HARTLEY, *David*, M. A. born at Ilingworth, where his father was curate, received his academical education at Jesus college, Cambridge, of which he was a fellow. He first began to practise physic at Newark, in Nottinghamshire; from whence he removed

Hartley
Harutsch.

ved to St Edmund's Bury, in Suffolk. After this, he settled for some time in London; and lastly went to live at Bath, where he died in 1757, aged 53, leaving two sons and a daughter. He published "A view of the present evidence for and against Mrs Stephens's medicines as a solvent for the stone, containing 155 cases, with some experiments and observations;" London 1739. He is said to have also written against Dr Warren, of St Edmund's Bury, in defence of inoculation; and some letters of his are to be met with in the Philosophical Transactions. The doctor was certainly a man of learning, and reputed a good physician; but too fond of nostrums. But his most considerable literary production is a work entitled, "Observations on man, his frame, his duty, and his expectations, in two parts;" London, 1749, 2 vols. 8vo. The first part contains observations on the frame of the human body and mind, and on their mutual connections and influences. The second part contains observations on the duty and expectations of mankind.

HARTOGIA, a genus of plants belonging to the monœcia class, and in the natural method ranking under the 48th order, *Aggregata*. See **BOTANY Index**.

HARUSPICES, pretenders to divination by certain signs or omens among the Romans.—The Roman haruspices were at first all taken from Hetruria, where their art had most credit. Afterwards young Romans were sent into Hetruria, in order to be brought up in the science. It consisted in foretelling future events by attending to various circumstances of the victims. First, It was an ill omen when the victim would not come to the altar without dragging, when it broke its rope, fled away, avoided the stroke, struggled much after it, made a great bellowing, was long a-dying, or bled but little. Secondly, Presages were drawn from inspecting the noble parts of the victim when opened; as the heart, lungs, spleen, and especially the liver. If all these were sound, if the top of the liver was large and well made, and if its fibres were strong, it presaged well for the affair in question. Thirdly, Knowledge was also drawn by the haruspices from the manner in which the fire consumed the victim. If the flame brightened immediately, was pure and clear, rose up in a pyramid without noise, and did not go out till the victim was consumed, these were happy signs. Fourthly, The smoke also was considered, whether it whirled about in curls, or spread itself to the right or the left, or gave a smell different from the common one of broiled meat. Fifthly, It was a lucky omen if the incense they burned melted all at once, and gave a most agreeable smell.

HARUSPICY. See **HARUSPICES** and **DIVINATION**.

HARUTSCH, a mountainous region in the interior of Africa, which Mr Horneman calls the most remarkable region which came under his observation during his journey. It presents such a rugged, broken and terrific scene, as naturally leads to the supposition, that its surface has been, at some remote period, convulsed by volcanic eruptions. The face of the whole country exhibits continued ranges of hills, some not more than 12 feet above the plain, and others extremely lofty.

Contiguous to this region, which is called *Harutsch-*

el-assuat, or *Black Harutsch*, lies the White Harutsch or *Harutsch-el-abiat*. This latter country is a vast plain which spreads to the mountains rising towards Fezzan, and is interspersed with isolated mountains.

Many of the hills contain petrifications, and the matter of which they are composed is friable limestone, in which the petrifications are very loosely imbedded, and may be taken out with ease. In these Mr Horneman found, among other marine productions, the heads of fishes so large, that one of them would have been a sufficient burden for an ordinary man. Vast numbers of shells are likewise found in the adjacent valleys, which have the appearance of being glazed, and have a vitreous fracture. It is not the abode of man, but the Arabian caravans frequently pass through it. The extent of this region is said to be seven days journey from north to south, and five days from east to west. It lies between 15° and 20° E. Long. and between 28° and 30° N. Lat. *Horneman's Travels*, p. 48.

HARVEST, probably derived from a Saxon word signifying *herb feast*, is that season of the year when the corn is ripe and fit to be reaped and gathered into barns.

HARVEST-Fly, a large four-winged fly of the cicada kind, very common in Italy, and erroneously supposed to be a grasshopper. See **CICADA**, **ENTOMOLOGY Index**.

HARVEST-Home, denotes the feast often observed at the close of harvest, and also the song used on that occasion. See **DECEMBER**.

HARVEY, DR WILLIAM, an eminent English physician in the 17th century, was incorporated doctor of physic in Cambridge, afterwards admitted into the college of physicians in London, and was appointed lecturer of anatomy and chirurgery in that college. In these lectures he opened his discovery relating to the circulation of the blood; which, after a variety of experiments, he communicated to the world in his *Exercitatio anatomica de motu cordis et sanguinis*. He was physician to King James I. and to King Charles I. and adhered to the royal cause. His works have eternized his memory. In 1651, he published his *Exercitationes de generatione animalium*, a very curious work; but it would have been more so, had not his papers been destroyed during the civil wars. In 1654, he was chosen president of the college of physicians in his absence: but his age and weakness were so great, that he could not discharge the duty of that office; and therefore desired them to choose Dr Fringle. As he had no children, he settled his paternal estate upon the college. He had three years before built a combination-room, a library, and a museum; and in 1656 he brought the deeds of his estate, and presented them to the college. He was then present at the first feast, instituted by himself, to be continued annually, together with a commemoration speech in Latin, to be spoken on the 18th of October, in honour of the benefactors to the college; he having appointed a handsome stipend for the orator, and also for the keeper of the library and museum, which are still called by his name. He died in 1657.

This great physician had the happiness, in his lifetime, to find the clamours of ignorance, envy, and prejudice, against his doctrine, totally silenced, and to see it universally established. It has by length of

Harutsch
Harvey.

Harvey time, been more and more confirmed, and every man now sees and knows it from his own experience. It appears to be of the utmost importance in medicine; as it is perhaps impossible to define health and sickness in fewer words, than that the one is a free, and the other an obstructed, circulation. Dr Harvey was not only an excellent physician, but an excellent man; his modesty, candour, and piety, were equal to his knowledge; the farther he penetrated into the wonders of nature, the more he was inclined to venerate the Author of it.

HARWICH, a town of Essex, in England, 72 miles from London. It is not large; but is well built, has a good maritime trade, is almost encompassed by the sea, and has strong works. It is walled in; and the streets are paved for the most part with clay, which tumbling down from the cliff, where is a petrifying water between the town and Beacon-Hill, soon grows as hard as stone; and the inhabitants boast the wall is as strong and the streets are as clean as those that are of real stone. The harbour or bay is very large, safe, and deep; and is commanded by a strong fort on the Suffolk side, though not in that county. Here is a dock belonging to the government, with all conveniences for building, cleaning, and refitting men of war. A little way from the town, on a high hill called *Beacon hill*, is a very fine light-house, which is seen at a great distance, and is very useful on this dangerous coast. At this place the packet boats which pass between England and Holland are stationed, and the town is much benefited by the passengers. The bay is so spacious, by the influx of the Stour from Manningtree, and the Orwell from Ipswich, and such use was made of it in the Dutch war, that 100 sail of men of war have been seen there at one time, with their tenders, besides 300 or 400 sail of colliers; for it is a perfect harbour to within two miles of Ipswich, and able to receive ships of 100 guns all the way. The inns here are very good; but the accommodations dear, by reason of the great concourse of passengers to and from Holland, which was the motive of fitting up sloops to go thither directly from the Thames, when the stage-coaches that used to ply two or three times a week between this place and London were laid down. This place was first made a free borough in the reign of Edward II. Its government was settled by the charter of King James I. in a mayor, chosen yearly, November 30. out of eight aldermen, who with 24 capital burgesses, the electors, and the recorder, make the corporation. By this charter it had also a power to elect two burgesses to parliament, the grant of its Friday market, and its two fairs on May-day and October 18. which are each for three days. The town has also an admiralty jurisdiction within its liberties, &c. The inhabitants in 1811 amounted to 3732. Though the entrance into the sea here is between two and three miles wide at high-water, yet the channel where the ships must keep to come to the harbour, which is on the Suffolk side, is deep and narrow; so that all ships that come in or go out are commanded by the guns of Languard-Fort on that side. This town was formerly fortified on the land side, but in the reign of King Charles I. the fortifications were demolished. It has since been ordered to be refortified. The church here, ever since the Reformation, has been a chapel to the

mother-church at Dover-Court. E. Long. 1. 7. N. Lat. 51. 56.

HARWOOD, a small town in the north riding of Yorkshire. Near it are the ruins of an ancient castle, and also Harwood-House, one of the first in the county for elegance. In the church are some ancient monuments, particularly that of lord chief-justice Gascoigne, who committed the prince of Wales to prison for striking him on the bench.

HARWOOD, *Great* and *Little*, the name of two villages in Lancashire, and of a small village in Northumberland.

HARZ, or **HARTZ**, a forest and mountain in the principality of Grubenhagen in Germany, in length 48 miles, and in breadth about 20. The forest which covers the mountain consists of a great variety of wood, which is of much importance to the numerous forges and manufactories of iron, which have been long established in this district. Beside abundance of the ores of iron, the Hartz yields other metallic ores in considerable quantity, as those of copper, lead, silver, zinc, and sometimes gold. The mining operations have been long carried on to a very great extent in this mountainous region.

HASLEMERE, a town of Surrey, in England, seated on the edge of the county next Hampshire, 43 miles from London, is an ancient place, and was once destroyed by the Danes. It is a borough by prescription, and has sent members to parliament ever since the reign of Edward IV. who are chosen by a bailiff and burgrave-teeners. It is said to have had seven parish-churches formerly, though but one church now, which is a chapel of ease to Chidinfold; and that it stood heretofore upon a hill more to the south than the present town. Population 756 in 1811.

HASSELQUIST, **FREDERIC**, was a native of East Gothland, and born in the year 1722. He prosecuted his medical and botanical studies at Upsal. The great Linnæus having represented in his lectures what important advantages might be gained by a young student, by travelling through the country of Palestine, at that time but little known, Hasselquist felt the fire of ambition burn within him at the declaration of his master. The crown giving no pecuniary encouragement for undertakings of this magnitude, extensive collections were made by private individuals, especially from the country of our author, and stipends were granted him by all the faculties in the university of Upsal.

Protected in this manner, he began his journey in 1749 during the summer season, and he obtained a passage to Smyrna in a Swedish East-Indiaman, through the influence of Lagerstroem. The Swedish consul at Smyrna received him in the most friendly manner, at which place he arrived about the latter end of the year. In the beginning of 1750 he set out for Egypt, and remained in the metropolis of that country for about nine months, from which place he transmitted to Linnæus some specimens of his researches, which obtained the approbation of the public after they were published. By the influence of Dr Wargentini, a collection of 10,000 dollars of copper currency was made for the encouragement of young Hasselquist in the prosecution of his researches. In the spring of 1751, he passed through Jaffa to Jerusalem, and returned afterwards to Smyrna by the way of Rhodes and Scio, completely

Hasselquist [**Hastings**] completely fulfilling the expectation of his country; but he did not live long enough to reap the fruits of his labours. His lungs were affected by the burning deserts of Arabia, and after languishing for some time in great distress, he expired in February 1752, before he had finished the 30th year of his age.

Having been under the necessity of contracting debt to the amount of 350*l.* all his collections were seized upon by the Turks, who threatened to expose them to sale; but Queen Louisa Ulrica redeemed them by the payment of 14,000 dollars of copper money, and they arrived at Stockholm in a state of excellent preservation. They were composed of Arabian manuscripts, shells, birds, serpents, insects, &c. An account of his voyage was published by Linnæus, by whom his memory was honoured with a plant which he called *Hasselquistia*.

HASSELQUISTIA, a genus of plants belonging to the pentandria class, and in the natural method ranking under the 45th order, *Umbellata*. See **BOTANY Index**.

HASSELT, a handsome town of the United Provinces, in Overijssel, seated on the river Wecht, in E. Long. 6. 5. N. Lat. 23. 46.

HASSELT, a town of Germany, in the circle of Westphalia, and in the territory of Liege, situated on the river Demer, in E. Long. 4. 49. N. Lat. 50. 55.

HASSIDEANS, or **ASSIDEANS**. See **ASSIDEANS**.

HASSOCK, a bass made of rushes, to kneel or rest the feet upon in churches.

HASP and **STAPLE**, in *Scots Law*, the symbol commonly used in burgage tenements for entering and in-
festing an heir, by delivering into his hands the hasp and staple of the door.

HASTA, or *HASTA Pura*, among medalists, signifies a kind of spear or javelin, not shod or headed with iron; or rather an ancient sceptre, somewhat longer than ordinary, occasionally given to all the gods.

The hasta is supposed a symbol of the goodness of the gods, and of the conduct of providence, which is equally mild and forcible.

HASTA, in some countries, is a measure or quantity of ground amounting to thirty paces: thus called, according to M. Du Cange, from the hasta or rod wherewith it was measured.

HASTATED LEAF, in *Botany*, a leaf of the shape of a spear.

HASTING-PEAR, a name given by the gardeners to a species of pear, called also by some the *green chissel pear*. This is a moderately large pear, and is longish towards the pedicle; its skin is thin, and of a whitish green; the pulp is melting, and of a sugary flavour. It ripens in July.

HASTINGS, a town of Sussex in England, 64 miles from London. It is the chief of the cinque-ports; and was formerly obliged to find 21 ships, within 40 days after the king's summons, well furnished and armed for service, and to maintain the crews a fortnight at its own charge. The town is supposed to have taken its name from Hastings, the famous Danish pirate, who used to build fortresses when he went ashore for his prey, to cover his men, and secure his retreat. In King Athelstaa's reign here was a mint. This town had charters from Edward the Confessor, William I. and II. Henry II. Richard I. Henry III.

Edward I. and Charles II. exempting it from toll, and empowering it to hold courts of judicature on life and death. It is incorporated by the style of mayor, jurats, and commonalty. It has handsome houses, and customhouse officers; but frequent storms have rendered it an indifferent harbour, though a vast sum of money has been laid out at times to make it a good one. It has sent members to parliament ever since Edward III. London is supplied from hence with abundance of fish that are taken on the coast. The town lies between two high cliffs towards the sea, and as high a hill on the land side, having two streets, and in each a parish-church, divided by a stream of fresh water called the Bourne. About the year 1377, this town was burnt by the French; and after it was rebuilt, it was divided into the two parishes. Here are two charity-schools, erected for the teaching of 200 or 300 children. There was a castle on the hill, which overlooked the town, but it is now in ruins. The markets here are on Wednesdays and Saturdays: the fairs are on Tuesday and Wednesday in Whitsun-week, and July 26. October 23. and 24. Here was formerly a priory. Hastings was a barony in the Huntingdon family, now in the Rawdon family. Population 3848 in 1811.

This town is remarkable for a battle fought in its neighbourhood, between Harold king of England and William duke of Normandy, on the 15th of October 1066, in which the former was defeated and killed; and by his death William, surnamed the *Conqueror*, became king of England: (see **ENGLAND**, N° 86.)—The night before the battle, the aspect of things was very different in the two camps. The English spent the time in riot, jollity, and disorder; the Normans in prayer and other duties of religion. The next day both armies prepared for battle. The duke divided his army into three lines: the first, headed by Montgomery, consisted of archers and light-armed infantry: the second, commanded by Martel, was composed of his bravest battalions, heavy-armed, and ranged in close order: his cavalry, at whose head he placed himself, formed the third line; and were so disposed, that they stretched beyond the infantry, and flanked each wing of the army. He ordered the signal of battle to sound: and the whole army, moving at once, and singing the hymn or song of Roland the famous peer of Charlemagne, advanced, in order and with alacrity, towards the enemy.

Harold had seized the advantage of a rising ground, and having besides drawn some trenches to secure his flanks, he resolved to stand upon the defensive, and to avoid all action with the cavalry, in which he was inferior. The Kentish men were placed in the van, a post which they had always claimed as their due; the Londoners guarded the standard; and the king himself, accompanied by his two valiant brothers, Gurth and Leofwin, dismounting from horseback, placed himself at the head of his infantry, and expressed his resolution to conquer or to perish in the action. The first attack of the Normans was desperate, but was received with equal valour by the English: and after a furious combat, which remained long undecided, the former, overcome by the difficulty of the ground, and hard pressed by the enemy, began first to relax their vigour; then to give ground; and confusion was spreading among the ranks, when William, who found himself

Hastings. self on the brink of destruction, hastened, with a select band, to the relief of his dismayed forces. His presence restored the action; the English were obliged to retreat with loss; and the duke, ordering his second line to advance, renewed the attack with fresh forces and with redoubled courage. Finding that the enemy, aided by advantage of the ground, and animated by the example of their prince, still made a vigorous resistance, he tried a stratagem, which was very delicate in its management, but which seemed advisable in his desperate situation, when, if he gained not a decisive victory, he was totally undone: he commanded his troops to make a hasty retreat, and to allure the enemy from their ground by the appearance of flight. The artifice succeeded against these unexperienced troops; who heated by the action, and sanguine in their hopes, precipitately followed the Normans into the plain. William gave orders, that at once the infantry should face about upon their pursuers, and the cavalry make an assault upon their wings, and both of them pursue the advantage which the surprise and terror of the enemy must give them in that critical and decisive moment. The English were repulsed with great slaughter, and driven back to the hill; where being rallied again by the bravery of Harold, they were able, notwithstanding their loss, to maintain the post and continue the combat. The duke tried the same stratagem a second time with the same success; but even after this double advantage, he still found a great body of the English who, maintaining themselves in firm array, seemed determined to dispute the victory to the last extremity. He ordered his heavy-armed infantry to make the assault upon them; while his archers, placed behind, should gail the enemy, who were exposed by the situation of the ground, and who were intent in defending themselves against the swords and spears of the assailants. By this disposition he at last prevailed. Harold was slain by an arrow, while he was combating with great bravery at the head of his men. His two brothers shared the same fate; and the English discouraged by the fall of these princes, gave ground on all sides, and were pursued with great slaughter by the victorious Normans. A few troops, however, of the vanquished dared still to turn upon their pursuers; and taking them in deep and miry ground, obtained some revenge for the slaughter and dishonour of the day. But the appearance of the duke obliged them to seek their safety by flight, and darkness saved them from any farther pursuit by the enemy.

Thus was gained by William duke of Normandy, the great and decisive victory of Hastings, after a battle which was fought from morning till sunset, and which seemed worthy, by the heroic feats of valour displayed by both armies, and by both commanders, to decide the fate of a mighty kingdom. William had three horses killed under him; and there fell near 15,000 men on the side of the Normans. The loss was still more considerable on that of the vanquished; besides the death of the king and his two brothers. The dead body of Harold was brought to William, who restored it without ransom to his mother.

HASTIVE, a French term, sometimes used in English for early, forward, or something that comes before the ordinary time or season. The hastive fruits are strawberries and cherries. We have hastive peas, &c.

Hastive
||
Hat-Making.

HAT, a covering for the head, worn by the men throughout the western part of Europe. Hats are said to have been first seen about the year 1400, at which time they became of use for country wear, riding, &c. F. Daniel relates, that when Charles VII. made his public entry into Rouen, in 1449, he had on a hat lined with red velvet, and surmounted with a plume or tuft of feathers: he adds, that it is from this entry, or at least under this reign, that the use of hats and caps is to be dated, which henceforward began to take place of the chaperoons and hoods that had been worn before. In process of time, from the laity, the clergy also took this part of the habit; but it was looked on as a great abuse, and several regulations were published, forbidding any priest or religious person to appear abroad in a hat without coronets; and enjoining them to keep to the use of chaperoons, made of black cloth, with decent coronets; if they were poor, they were at least to have coronets fastened to their hats, and this upon penalty of suspension and excommunication. Indeed the use of hats is said to have been of a longer standing among the ecclesiastics of Brittany, by 200 years, and especially among the canons; but these were no other than a kind of caps, and from hence arose the square caps worn in colleges, &c. Lobineau observes, that a bishop of Dol, in the 12th century, zealous for good order, allowed the canons alone to wear such hats; enjoining, that if any other person came with them to church, divine service should immediately be suspended.

Hats make a very considerable article in commerce: the finest, and those most valued, are made of pure hair of an amphibious animal, called the castor or beaver, frequent in Canada and other provinces of North America.

HAT-Making. Great improvements have been made in this art of late years by ingenious and intelligent manufacturers. For the following account of the different processes of this manufacture we are indebted to Mr Nicholson, from whose Journal it is extracted; and to John Clennell, Esq. of Newcastle, Mr Nicholson's correspondent on this subject, who has highly favoured us with some valuable corrections of this account.

"The materials for making hats are rabbits and hares fur cut off from the skin, after the hairs have been plucked out, together with wool and beaver. The former are mixed in various proportions, and of different qualities, according to the value of the article intended to be made; and the beaver is universally used for facing the finer articles, and never for the body or main stuff. Experience has shewn, that these materials cannot be evenly and well felted together, unless all the fibres be first separated, or put into the same state with regard to each other. This is the object of the first process, called *bowing*. The material, without any previous preparation (A), is laid upon a platform of wood,

(A) Some writers mention a partial wetting of the fur while on the skin, by lightly smearing it with a solution of nitrate of mercury to give it a curl. Messrs Collinsons do not use it, or any other preparation.

Hat-Making.

wood, or of wire, somewhat more than four feet square, called a *hurdle*, which is fixed against the wall of the work-shop, and is enlightened by a small window, and separated by two side partitions from other hurdles, which occupy the rest of the space along the wall. The hurdle, if of wood, is made of deal planks, not quite three inches wide, disposed parallel to the wall, and at the distance of one-fortieth or one-fiftieth of an inch from each other, for the purpose of suffering the dust, and other impurities of the stuff, to pass through; a purpose still more effectually answered by the hurdle of wire.

“The workman is provided with a bow, a bow-pin, a basket, and several cloths. The bow is a pole of yellow deal wood, between seven and eight feet long, to which are fixed two bridges, somewhat like that which receives the hair in the bow of the violin (B). Over these is stretched a catgut, about one-twelfth part of an inch in thickness. The bow-pin is a stick with a knob at each end, and is used, for striking or catching the bow-string, by the vibration of which, as we shall shortly see, the stuff is thoroughly mixed. The basket is a square piece of osier work, consisting of open strait bars with no crossing or interweaving. Its length across the bars may be about two feet, and its breadth eighteen inches. The sides into which the bars are fixed are slightly bended into a circular curve, so that the basket may be set upright on one of these edges near the right hand end of the hurdle, where it usually stands. The cloths are linen. Besides these implements, the workman is also provided with brown paper.

“The *bowing* commences by shovelling the material towards the right hand partition with the basket, upon which, the workman holding the bow horizontally in his left hand, and the bow-pin in his right, lightly places the bow-string, and gives it a pluck with the pin. The string, in its return, strikes part of the fur, and causes it to rise, and fly partly across the hurdle in a light open form. By repeated strokes, the whole is thus subjected to the bow; and this beating is repeated till all the original clots or masses of the filaments are perfectly opened and obliterated. The quantity thus treated at once is called a *batt*, and never exceeds half the quantity required to make one hat.

“When the batt is sufficiently bowed, it is ready for *hardening*; which term denotes the first commencement

Hat-Making.

of felting. The material, thus far prepared, is seen on the hurdle swelling in the centre, and lessening gradually towards the edges. The reason of this is obvious; the hat is formed of two of these batts joined together, and by their union the whole becomes equally compact. It is now pressed down by the convex side of the basket, then covered with a cloth, and pressed successively in its various parts by the hands of the workman. The pressure is gentle, and the hands are very slightly moved back and forwards at the same time through a space of perhaps a quarter of an inch, to favour the hardening or entangling of the fibres. In a very short time, indeed, the stuff acquires sufficient firmness to bear careful handling. The cloth is then taken off, and a sheet of paper, with its corners doubled in, so as to give it a triangular outline, is laid upon the batt, which last is folded over the paper as it lies, and its edges, meeting one over the other, form a conical cap. The joining is soon made good by pressure with the hands on the cloth. Another batt, ready hardened, is in the next place laid on the hurdle, and the cap here mentioned placed upon it, with the joining downwards: By this means, as we before stated, the mass becomes uniform in thickness, and assumes the form of a flannel bag. This last batt being also folded up, will consequently have its place of junction diametrically opposite to that of the inner felt, which it must therefore greatly tend to strengthen. The principal part of the hat is thus put together, and now requires to be worked with the hands a considerable time upon the hurdle, the cloth being also occasionally sprinkled with clear water. During the whole of this operation, which is called *basoning*, (C), the article becomes firmer and firmer, and contracts in its dimensions. It may easily be understood, that the chief use of the paper is to prevent the sides from felting together.

“The basoning is followed by a still more effectual continuation of the felting, called *working* (D). This is done in another shop, at an apparatus called a *battery*, consisting of a *kettle* (containing water slightly acidulated with sulphuric acid, to which, for beaver hats, a quantity of the grounds of beer is added, or else plain water for rinsing out), and eight *planks* of wood joined together in the form of a frustum of a pyramid, and meeting in the kettle at the middle. The outer or upper edge of each plank is about two feet broad, and rises a little more than two feet and a half above the ground;

(B) The bow is best made of ash; it is composed of the *stang* or handle: the bridge at the smaller end, or that which is nearest the window in the act of bowing, is called the *cock*; and the other bridge, which is nearer to the workman's hand, is called the *breoch*.

(C) After bowing, and previous to the basoning, a *hardening skin*, that is, a large piece of skin, about four feet long and three feet broad, of leather alumed or half tanned, is pressed upon the batt, to bring it by an easier gradation to a compact appearance; after which it is basoned, being still kept upon the hurdle. This operation, the basoning, derives its name from the process or *mode of working*, being the same as that practised upon a wool hat after bowing; the last being done upon a piece of cast metal, four feet across, of a circular shape, called a *bason*: the joining of each batt is made good here by shuffling the hand, that is, by rubbing the edges of each batt folded over the other to excite the progressive motion of each of the filaments in felting, and to join the two together.

(D) Before this operation is begun, the hat is dipped into the boiling kettle, and allowed to lie upon the plank until cold again; this is called *soaking*; that is, being perfectly saturated with the hot liquor: if they are put in too hastily in this state, for they are then only bowed and basoned, they would burst from the edges, each batt not being sufficiently felted into the other.

Hat-Making.

ground; and the slope towards the kettle is considerably rapid, so that the whole battery is little more than six feet in diameter. The quantity of sulphuric acid added to the liquor is not sufficient to give a sour taste, but only renders it rough to the tongue. In this liquor, heated rather higher than unpractised hands could bear, the article is dipped from time to time, and then worked on the planks with a roller, and also by folding or rolling it up, and opening it again; in all which, a certain degree of care is at first necessary, to prevent the sides from felting together; of which, in the more advanced stages of the operation, there is no danger. The imperfections of the work now present themselves to the eye of the workman, who picks out knots and other hard substances with a bodkin, and adds more felt upon all such parts as require strengthening. This added felt is patted down with a wet brush, and soon incorporates with the rest. The beaver is laid on towards the conclusion of this kind of working. Mr Nicholson could not distinctly learn why the beer grounds were used with beaver hats. Some workmen said, that by rendering the liquor more tenacious, the hat was enabled to hold a greater quantity of it for a longer time; but others said, that the mere acid and water would not adhere to the beaver facing, but would roll off immediately when the article was laid on the plank. It is probable, as he observes, that the manufacturers who now follow the established practice, may not have tried what are the inconveniences this addition is calculated to remove.

"The journeymen tell me (says Mr Clennell), that the dregs are to hold or fill the body, whilst a little vitriol cleanses it of the dirt, &c. that may be on the rabbit or other wool; too much vitriol would make the whole that was weighed out to the journeymen work into the hats, but by the mutual action of the vitriol and the dregs, the quantity of the first being small, about a wine glassfull, the dirt and the strong hairs get purged out (the last from the shrinking in being slow, as well as their being straight; for was the lessening of the size at plank rapid, they would, in defiance of their straightness, get entangled, and even as it is, they are slightly so; but care is taken to get them out by rubbing the body of the hat well with the hand in a circular manner) whilst, at the same time, the dregs keep the hats plump. Another advantage attending the use of dregs, whether of beer, porter, or wine, is that as the boiling in the dregs does not draw out much of the mucilage from each hat, when they come to be stiffened the dregs form a body within the hat sufficiently strong or retentive to keep the glue from coming through amongst the nap; vitriol alone would purge or weaken the hats too much, consequently, half the quantity does better with the addition of dregs, and they disallow the body to be closer from its getting more work: many journeymen, however, to hurry this part of the process, use a quantity of vitriol, and open the body again by throwing in a handful or two of oatmeal; by this means they get a great many made, though at the same time they are left quite grainy from the want of labour. This, in handling the dry gray hat, when made, may be in part discovered, but in part only; in wearing the effect is shining spots, as if of grease, but is, in reality, the glue lodging upon the grainy parts."

5

Hat-Making.

Of these reasons for the use of dregs, the last only appears to be perspicuous or at all satisfactory. Acid of any kind, by taking out the greasy substances on each pile of hair, allows the roughnesses on the surface of each to operate with their full effect, and thus facilitates the mechanical action of felting; and Mr Collinson informed Mr Nicholson, that in a process, called *carotting*, they make use of nitrous acid. In this operation, the material is put into a mixture of the nitrous and sulphuric acids in water, and kept in the digesting heat of a stove all night; by which means the hair acquires a ruddy or yellow colour, like the inner part of a carrot, from which it derives its name, and though it loses part of its strength it receives a curl which more readily promotes the action of felting.

"It must be remembered, that our hat still possesses the form of a cone, and that the whole of the several actions it has undergone have only converted it into a soft flexible felt, capable of being extended, though with some difficulty, in every direction. The next thing to be done is to give it the form required by the wearer. For this purpose, the workman turns up the edge or rim to the depth of about an inch and a half, and then returns the point back again through the centre or axis of the cap, so far as not to take out this fold, but to produce another inner fold of the same depth. The point being returned back again in the same manner, produces a third fold; and thus the workman proceeds, until the whole has acquired the appearance of a flat circular piece, consisting of a number of concentric undulations or folds, with the point in the centre. This is laid upon the plank, where the workman, keeping the piece wet with the liquor, pulls out the point with his fingers, and presses it down with his hand, at the same time turning it round on its centre in contact with the plank, till he has, by this means, rubbed out a flat portion equal to the intended crown of the hat. In the next place, he takes a block, to the crown of which he applies the flat central portion of the felt, and by forcing a string down the sides of the block, he causes the next part to assume the figure of the crown, which he continues to wet and work, until it has properly disposed of itself round the block. The rim now appears like a flounced or puckered appendage round the edge of the crown; but the block being set upright on the plank, the requisite figure is soon given by working, rubbing, and extending this part. Water only is used in this operation of fashioning or blocking; at the conclusion of which it is pressed out by the same copper implement by which he drove down the card.

"Previous to the dyeing, the nap of the hat is raised or loosened out with a wire brush, or carding instrument. The fibres are too rotten after the dyeing to bear this operation; or if they could bear the operation, the colour of the hat would not be uniform, from a part of the nap having been confined, and consequently not receiving the full action of the dye liquor. The dyeing materials are logwood, and a mixture of the sulphates of iron and of copper, known in the market by the names of green copperas and blue vitriol. As the time of Mr Collinson was limited, and my attention, says Mr Nicholson, was more particularly directed to the mechanical processes, I did not go into the dye-house; but I have no doubt that the hats are boiled

with

Hat-
making.

with the logwood, and afterwards immersed in the saline solution, I particularly asked whether galls were used, and was answered in the negative.

"The dyed hats are, in the next place, taken to the stiffening shop. One workman, assisted by a boy, does this part of the business. He has two vessels, or boilers, the one containing the grounds of strong beer, which costs seven shillings per barrel, and the other vessel containing melted glue, a little thinner than it is used by carpenters. Our author particularly asks, whether this last solution contained any other ingredient besides glue, and was assured that it did not. The beer grounds are applied in the inside of the crown to prevent the glue from coming through to the face, and also, as he supposes, to give the requisite firmness at a less expence than could be produced by glue alone. If the glue were to pass through the hat in different places, it might, he imagines, be more difficult to produce an even gloss upon the face in the subsequent finishing. The glue stiffening is applied after the beer grounds are dried, and then only upon the lower face of the flap, and the inside of the crown. For this purpose, the hat is put into another hat, called a stiffening hat, the crown of which is notched, or slit open in various directions. These are then placed in a hole in a deal board, which supports the flap, and the glue is applied with a brush.

"The dry hat, after this operation, is very rigid, and its figure irregular. The next operation, therefore, is clearing with soap and boiling water to cleanse the glue from the nap or pile; it is then dried. The last dressing is given by the application of moisture and beat, and the use of the brush, and a hot iron, somewhat in the shape of that used by tailors, but shorter and broader on the face. The hat being softened by exposure to steam, is drawn upon a block, to which it is securely applied by the former method of forcing a string down from the crown to the commencement of the rim. The judgment of the workman is employed in moistening, brushing, and ironing the hat, in order to give and preserve the proper figure. When the rim of the hat is not intended to be of an equal width throughout, it is cut by means of a wooden, or perhaps metallic pattern; but as no such hats are now in fashion, Mr Nicholson saw only the tool for cutting them round. The contrivance is very ingenious and simple. A number of notches are made in one edge of a flat piece of wood for the purpose of inserting the point of a knife, and from one side or edge of this piece of wood there proceeds a straight handle, which lies parallel to the notched side, forming an angle somewhat like that of a carpenter's square. When the legs of this angle are applied to the outside of the crown, and the board lies flat on the rim of the hat, the notched edge will lie nearly in the direction of the radius, or line pointing to the centre of the hat. A knife being therefore inserted in one of the notches, it is easy to draw it round by leaning the tool against the crown, and it will cut the border very regular and true. This cut is made before the hat is quite finished, and is not carried entirely through; so that one of the last operations consists in tearing off the redundant part, which by that means leaves an edging of beaver round the external face of the flap. When the hat is completely finished, the crown is tied up in gauze paper, which is

VOL. X. Part I.

neatly ironed down. It is then ready for the subsequent operations of lining," &c.

This valuable memoir on the fabrication of hats is concluded with some observations on the probable gain or loss of employing machinery in the manufacture. These observations we recommend to the serious attention of every judicious hat-maker, who carries on his business on a large scale; for he will find them not the reveries of a rash speculatist, but the cool reflections of a real philosopher, who is at the same time no stranger to the arts of life. They suggest the following subjects of enquiry: Whether carding, which is rapidly and mechanically done, be inferior to bowing, which does not promise much facility for mechanical operation? Whether a succession of batts or cardings might be thrown round a fluted cone, which rapidly revolving, in contact with three or more cylinders, might perform the barding, and even the working, with much more precision and speed than they are now done by hand? Whether blocking or shaping be not an operation extremely well calculated for the operation of one or more machines? Whether loose weaving and subsequent felting might not produce a lighter, cheaper, and stronger article? And how far the mechanical felting, which is not confined merely to the hairs of animals, might be applied to this art? ^{e Nichols.}

Mr Dunnage has proposed a method of making *water-proof hats*, in imitation of beaver, for which, in November 1794, he obtained a patent. This method is as follows: Let a shag be woven, of such count in the reed, and cut over such sized wire, as will give the hats to be manufactured from it that degree of richness, or appearance of fur, which may be thought necessary. The materials of which this shag may be composed are various, and should be accommodated to different kinds of hats, according to the degree of beauty and durability to be given them, and the price at which they are designed to be sold; that is to say, silk, mohair, or any other hair that is capable of being spun into an end fine enough for the purpose, cotton, inkle, wool, or a mixture of any, or all the above materials, as may suit the different purposes of the manufacturer. Those answer best, (says our author), which are made with two poles, either of Bergam, Piedmont, or Organzine silk, rising alternately, in a reed of about nine hundred count to eighteen inches wide, with three shoots over each wire. This method of weaving distributes the silk (as it may be put single into the harness), and prevents any ribby appearance which it might have if the silk were passed double, and the whole of the pole cut over each wire. This may be made either on a two or four thread ground of hard silk, shot with fine cotton, which he thinks preferable for shoots, to silk, inkle, or any other material, as it forms both a close and fine texture. An inferior kind of hats may be made from any of the before-mentioned materials, and with cheaper silk. This shag should be stretched on a frame, such as dyers use to rack cloth; then (having previously set the pile upright with a comb, to prevent its being injured or stuck together), go over the ground with thin size, laid on with a soft brush. For black, or dark colours, common size will do; with white or any light colour, use isinglass, or a size made from white kid leather. These, or gum, or any other mucilaginous matter, which, without altering the colour, will prevent oil from getting through the ground so as to

Hat-
making.Nichols.
Journ. 4to.
vol. iv. 73.

O o

Digitized by Google injure

Hat-making.

injure the pile, will answer the purpose. Take care not to apply more of any material, as a preparation, than may be fully saturated with oil or varnish, so that water will not discharge it from the ground. The size, or rather glutinous matter, being dry, the pile must be teased, or carded with a fine card, till the silk is completely taken out of the twist or throwing, when it will lose its coarse shaggy look, and assume the appearance of a very fine fur. It must now be once more set upright with a comb, and you may proceed to lay on your water-proof material; this too may be varied according to circumstances. For black, or any dark colour, linseed oil well boiled with the usual driers, and thickened with a small quantity of any good drying colour, will do; for white, or very fine colours, poppy or nut oil, or copal or other varnishes, may be used. In this particular the manufacturer must judge what will best answer his purpose, taking care never to use any thing that will dry hard, or be subject to crack. Mr Dunnage has found good drying linseed oil preferable to any other thing which he has used, and, with the precaution of laying on very little the first time, it will not injure the finest colours. When the first coat of oil is dry, go over it a second and a third time, if necessary, till you are convinced the pores of the ground are fully closed up, and the stuff rendered impervious to water. It should now stand several days, till the smell is sufficiently gone off, and before it is taken from the frame, should be gone over with some ox gall or lime-water, to take off the greasiness, which would otherwise prevent the stiffening from adhering to the oil. The material being now ready to be formed into hats, should be cut into proper shapes for that purpose. The crown should be made up over a block, with needle and silk, the oiled side outwards. The seams should then be rubbed with a piece of hard wood, bone, or ivory, to make them lie flat, and the edges of the stuff pared off very near the stitches, that no joint may appear on the right side. The seams should then be carefully gone over with the prepared oil, till every crevice or hole made by the needle is completely filled up, and the crown rendered perfectly water-proof. The crown may then be turned and stiffened, by sticking linen, leather, paper, or any other material that may be found to answer the purpose, to the inner or painted side, till it acquires about the same degree of stiffness, or resistance to the touch, as a good beaver. The mucilaginous matter which he used to attach the stiffening to the crown, and the upper and under parts of the brim to each other, was composed of one pound of gum-arabic or senega, one pound of starch, and half a pound of glue, boiled up with as much water as reduced the whole to the consistence of a thick paste. A greater or less proportion of any of these ingredients may be used, and other glutinous and adhesive substances may answer the same purposes; or drying-oils may be made use of instead of this or other mucilage; or any of the resinous gums dissolved in oil or spirits: only it should be observed, in this case, the hats will require more time in the preparation, as the oily matter, unless exposed to the air, will not readily dry; but he found by experience that the above-mentioned composition does not dry hard or brittle, but retains that pleasant flexibility which is agreeable to the touch, while it communicates to the other mate-

rials a sufficient degree of elasticity. Before the brim is perfectly dry, care should be taken to form a neck or rising round the hole where it is to be attached to the crown, by notching it round with a pair of scissors, and then forcing it over a block something larger than you have made the hole, so that the uncut stuff may turn up, under the lower edge of the crown, about a quarter of an inch. Before you join the crown and brim together, go over the outside of the neck of the brim, and the inside of the crown, as high as the neck will come (which should be about half an inch), with the prepared oil; and when they are nearly dry, so as to adhere to the finger on touching them, put the crown over the neck of the brim, and let them be sewed strongly together, taking care to sew down as little of the pile as possible, and using the same precaution of oiling, where the needle has been through, as was observed in making up the crown. The hat is now ready for dressing; which operation may be performed over a block, with a hot iron, brush, &c. in the same manner as these commonly called felt. When putting in the lining, be very careful to let the needle only take hold of the under surface of the brim; for should it perforate the upper one, the water will find its way through, and the hat be of no value. Though we have already declared how little we are acquainted with the operation of hat-making, we cannot help suggesting the enquiry, whether these water-proof hats might not be improved both in strength and beauty, by a slight felting before the application of the size by the brush. Such of them as are composed of wool or hair, or contain a mixture of these materials, are unquestionably susceptible of felting.

Dyeing of Hats. The instructions of Colbert direct hats to be first strongly galled, by boiling them a long time in a decoction of galls with a little logwood, that the dye may penetrate the better into their substance; after which a proper quantity of vitriol, and decoction of logwood, with a little verdigrise, are added, and the hats continued in this mixture also for a considerable time. They are afterwards to be put into a fresh liquor of logwood, galls, vitriol, and verdigrise; and where the hats are of great price, or of a hair which difficultly takes the dye, the same process is to be repeated a third time. For obtaining the most perfect colour, the hair or wool is to be dyed blue previously to its being formed into hats. But the following shorter process is generally practised.

A hundred pounds of logwood, 12 pounds of gum, and six pounds of galls, are boiled in a proper quantity of water for some hours; after which, about six pounds of verdigrise and ten of green vitriol are added, and the liquor kept just simmering, or of a heat a little below boiling. Ten or twelve dozen of hats are immediately put in, each on its block, and kept down by cross bars for about an hour and an half: they are then taken out and aired, and the same number of others put in their room. The two sets of hats are thus dipped and aired alternately, eight times each; the liquor being refreshed each time with more of the ingredients, but in less quantity than at first.

This process (says Dr Lewis) affords a very good black on woollen and silk stuffs as well as on hats, as we may see in the small pieces of both kinds which are sometimes dyed by the batters. The workmen lay

Hat-making.

Hat
Hatching.

great stress upon the verdigrise, and affirm that they cannot dye a black hat without it: it were to be wished that the use of this ingredient were more common in the other branches of the black dye; for the hatters dye, both on silk and woollen, is reckoned a finer black than what is commonly produced by the woollen and silk dyer.

But the general practice among hatters is to leave out the galls and verdigrise, on account of the advance in price, and to use blue vitriol instead of them, in the proportion of 5lb. to 12 dozen of hats, which is found to answer the purpose equally well.

HATS are also made for women's wear, not only of the above stuffs, but of chips, straw, or cane, by plaiting, and sewing the plaits together; beginning with the centre of the crown, and working round till the whole is finished. Hats for the same purpose are also woven and made of horse-hair, silk, &c.

HAT is also figuratively used for the dignity of cardinal, or a promotion to that dignity. In this sense they say, "to expect the hat; to claim, or have pretensions to, the hat," &c.

Pope Innocent IV. first made the hat the symbol or cognizance of the cardinals, enjoining them to wear a red hat at the ceremonies and processions, in token of their being ready to spill their blood for Jesus Christ.

HATCH, or HATCHWAY, a square or oblong opening in the DECK of a ship, of which there are several, forming the passages from one deck to another, and into the hold or lower apartments. See Plate CLXXIX. where A represents the main-hatchway of the lower deck; NN the fore-hatchway; and OO the after-hatchway.—There are likewise hatches of a smaller kind, called *scuttles*. See UU in the same figure; as also the article SCUTTLE. Hatches is also, though improperly, a name applied by the sailors to the covers or lids of the hatchway.

HATCHEL, or HITCHEL, in the manufactory of flax, hemp, &c. a tool, not unlike a card, for dressing and combing them into fine hairs.

They consist of sharp-pointed iron pins, or teeth, set orderly in a board.

Of these there are several sorts, some with finer and shorter teeth, others with them coarser and longer.

HATCHES, in mining, a term used in Cornwall, to express any of the openings of the earth either into mines or in search of them. The fruitless openings are called *essay-hatches*; the real mouths of the veins, *tin-hatches*; and the places where they wind up the buckets of ore, *wind-hatches*.

HATCHES also denote flood-gates set in a river, &c. to stop the current of the water, particularly certain dams or mounds made of rubbish, clay, or earth, to prevent the water that issues from the stream-works and tin-washes in Cornwall from running into the fresh rivers.

HATCHET, a small light sort of an axe, with a basil edge on its left side, and a short handle, as being to be used with one hand.—Hatchets are used by various artificers, and more particularly in hewing of wood.

HATCHING, the maturing fecundated eggs, whether by the incubation and warmth of the parent bird, or by artificial heat, so as to produce young chickens alive.

The art of hatching chickens by means of ovens has long been practised in Egypt; but it is there only

known to the inhabitants of a single village named *Berme*, and to those that live at a small distance from it. Towards the beginning of autumn they scatter themselves all over the country; where each person among them is ready to undertake the management of an oven, each of which is of a different size; but, in general, they are capable of containing from forty to fourscore thousand eggs. The number of these ovens placed up and down the country is about 386, and they usually keep them working for about six months: as, therefore, each brood takes up in an oven, as under a hen, only 21 days, it is easy in every one of them to hatch eight different broods of chickens. Every Bermean is under the obligation of delivering to the person who intrusts him with an oven, only two-thirds of as many chickens as there have been eggs put under his care; and he is a gainer by this bargain, as more than two-thirds of the eggs usually produce chickens. In order to make a calculation of the number of chickens yearly so hatched in Egypt, it has been supposed that only two-thirds of the eggs are hatched, and that each brood consists of at least 30,000 chickens; and thus it would appear that the ovens of Egypt give life yearly to at least 92,640,000 of these animals.

This useful and advantageous method of hatching eggs has been lately discovered in France by the ingenious Mr Reaumur; who, by a number of experiments, has reduced the art to certain principles. He found by experience, that the heat necessary for this purpose is nearly the same with that marked 32 on his thermometer, or that marked 96 on Fahrenheit's. This degree of heat is nearly that of the skin of the hen, and what is remarkable, of the skin of all other domestic fowls, and probably of all other kinds of birds. The degree of heat which brings about the development of the cygnet, the gosling, and the turkey-pout, is the same as that which fits for hatching the canary-songster, and, in all probability, the smallest humming-bird: the difference is only in the time during which this heat ought to be communicated to the eggs of different birds; it will bring the canary-bird to perfection in 11 or 12 days, while the turkey-pout will require 27 or 28.

After many experiments, Mr Reaumur found, that stoves heated by means of a baker's oven, succeeded better than those made hot by layers of dung: and the furnaces of glass-houses and those of the melters of metals, by means of pipes to convey heat into a room, might, no doubt, be made to answer the same purpose. As to the form of the stoves no great nicety is required. A chamber over an oven will do very well. Nothing more will be necessary but to ascertain the degree of heat; which may be done by melting a lump of butter of the size of a walnut, with half as much tallow, and putting it into a phial. This will serve to indicate the heat with sufficient exactness; for when it is too great, this mixture will become as liquid as oil; and when the heat is too small, it will remain fixed in a lump; but it will flow like a thick syrup, upon inclining the bottle, if the stove be of a right temper. Great attention therefore should be given to keep the heat always at this degree, by letting in fresh air if it be too great, or shutting the stove more close if it be too small; and that all the eggs in the stove may equally share the irregularities of the heat, it will be necessary to shift them

Hatching.

Hatching
H
Hatfield
and Chace.

from the sides to the centre; and thus to imitate the hens, who are frequently seen to make use of their bills, to push to the outer parts those eggs that were nearest to the middle of their nests, and to bring into the middle such as lay nearest the sides.

Mr Reaumur has invented a sort of low boxes, without bottoms, and lined with furs. These, which he calls *artificial parents*, not only shelter the chickens from the injuries of the air, but afford a kindly warmth, so that they presently take the benefit of their shelter as readily as they would have done under the wings of a hen. After hatching, it will be necessary to keep the chickens, for some time, in a room artfully heated and furnished with these boxes; but afterwards they may be safely exposed to the air in the court-yard, in which it may not be amiss to place one of these artificial parents to shelter them if there should be occasion for it.

As to the manner of feeding the young brood, they are generally a whole day after being hatched, before they take any food at all; and then a few crumbs of bread may be given them for a day or two, after which they will begin to pick up insects and grass for themselves.

But to save the trouble of attending them, capons may be taught to watch them in the same manner as hens do. Mr Reaumur assures, that he has seen above 300 chickens at once, all led about and defended only by three or four such capons. Nay, cocks may be taught to perform the same office; which they, as well as the capons, will continue to do all their lives after.

HATCHING, or **HACHING**, in designing, &c. the making of lines with a pen, pencil, graver, or the like; and the intersecting or going across those lines with others drawn a contrary way, is called *counter-hatching*. The depths and shadows of draughts are usually formed by hatching.

Hatching is of singular use in heraldry, to distinguish the several colours of a shield, without being illuminated: thus, gules or red is hatched by lines drawn from the top to the bottom; azure, by lines drawn across the shield; and so of other colours.

HATCHMENT, in *Heraldry*, the coat-of-arms of a person dead, usually placed on the front of a house, whereby may be known what rank the deceased person was of when living: the whole distinguished in such a manner as to enable the beholder to know whether he was a bachelor, married man, or widower; with the like distinctions for women.

HATFIELD, BISHOPS, a town of Hertfordshire, 19 miles north from London. It was called *Bishops Hatfield*, because it belonged to the bishops of Ely. Theodore archbishop of Canterbury held a synod here, anno 681, against the Eutychean heresy. Here was once a royal palace, from whence both Edward VI. and Queen Elizabeth were conducted to the throne. King James I. exchanged the manor with Sir Robert Cecil, afterwards earl of Salisbury, for Theobald's, in the parish of Cheshunt in this county; and the lordship still remains in that noble family, who have a very fine seat here. Population 2677 in 1811.

HATFIELD and Chace, a town in the west riding of Yorkshire, four miles from Doncaster. The chace is famous for deer-hunting. There are many intrench-

ments near the town, as if it had been the camp of some great army. It is said that no rats were ever seen in this town.

HATFIELD-BROAD-OAK, or *King's Hatfield*, a town of Essex in England, seated on a branch of the river Lea, 30 miles from London, is so called from the nature of the soil, from its tenure by King William the Conqueror and his successors, and from a broad oak growing in the town. It has a market on Saturdays, and a fair in August.

HATTEM, a town of the United Provinces, in the duchy of Guelderland, seated on the river Ussol, in E. Long. 6. o. N. Lat. 53. 30.

HATTEMISTS, in ecclesiastical history, the name of a modern Dutch sect, so called from Pontian Van Hattem, a minister in the province of Zealand, towards the close of the 17th century, who being addicted to the sentiments of Spinoza, was on that account degraded from his pastoral office. The Verschorists and Hattemists resemble each other in their religious systems, though they never so entirely agreed as to form one communion. The founders of these sects deduced from the doctrine of absolute decrees a system of fatal and uncontrollable necessity; they denied the difference between moral good and evil, and the corruption of human nature: from hence they farther concluded, that mankind were under no sort of obligation to correct their manners, to improve their minds, or to obey the divine laws; that the whole of religion consisted not in acting, but in suffering; and that all the precepts of Jesus Christ are reducible to this one, that we bear with cheerfulness and patience the events that happen to us through the divine will, and make it our constant and only study to maintain a permanent tranquillity of mind. Thus far they agreed; but the Hattemists farther affirmed, that Christ made no expiation for the sins of men by his death, but had only suggested to us by his mediation, that there was nothing in us that could offend the Deity; this, they say, was Christ's manner of justifying his servants, and presenting them blameless before the tribunal of God. It was one of their distinguished tenets, that God does not punish men for their sins, but by their sins. These two sects, says Mosheim, still subsist, though they no longer bear the names of their founders.

HATTOCK, a shock of corn containing twelve sheaves; others make it only three sheaves laid together.

HATUAN, a town and fort of Upper Hungary, in the county of Novigrod. It was taken by the Imperialists in 1685. It is seated on a mountain, in E. Long. 19. 48. N. Lat. 47. 52.

HAVANNA, a sea-port town in the island of Cuba, in the West Indies, and on the north-west part of it, opposite to Florida. It is famous for its harbour, which is in every respect one of the best in the West Indies, and perhaps in the world. It is entered by a narrow passage, upwards of half a mile in length, which afterwards expands into a large bason, forming three cul de sacs, and is sufficient, in extent and depth, to contain 1000 sail of the largest ships, having almost throughout six fathoms water, and being perfectly covered from every wind. The town was built by Diego de Velasquez, who conquered the island of Cuba. It was but a small place, and named originally the port of

Hatfield
and Chace
H
Havanna.

Havanna. Carenas; but afterwards, when the city by its increase of wealth grew considerable, it was called *St Christopher of the Havanna*. In 1536, it was of so inconsiderable a value, that being taken by a French pirate, he ransomed the place for the paltry sum of 700 pieces of eight. Some time after it was taken by the English, and a second time by the French: nor was its value understood, nor any care taken to put it in a posture of defence, till the reign of Philip II.; though what was then done proved insufficient. But since the accession of a branch of the house of Bourbon to the Spanish crown, more pains have been taken to render it a place of strength.

The Havanna stands on the west side of the harbour, in a pleasant plain; and is the residence of the governor and captain-general of Cuba, and of the royal officers, as well as of an assessor for the assistance of the governor and captain-general of the West Indies. The bishop of St Jago de Cuba likewise chooses to fix his residence here. The buildings are elegant, built of stone, and some of them most superbly furnished. Here are eleven churches and monasteries, and two handsome hospitals. Near the middle of the town is a spacious square, surrounded with uniform buildings. The churches are rich and magnificent; the lamps, candlesticks, and ornaments for the altars, being of gold and silver; and some of the lamps are of the most curious workmanship, and weigh near 100 weight. The Recollects church, which stands on the best ground in the city, has 12 beautiful chapels in it, and in the monastery are cells for 50 fathers. The church of St Clara has seven altars adorned with plate, and the nunnery contains 100 women and servants, all clothed in blue. The church belonging to the Augustines has 13 altars; that of St Juan de Dios 9, with an hospital for soldiers of 12,000 pieces of eight revenue. It is not a bishop's see, though the bishop of St Jago resides here, the revenue of which prelate is not less than 50,000 pieces of eight a-year. In 1700 the inhabitants were computed at 26,000, and we may very well imagine them to be increased since. They are a more polite and social people than the inhabitants of any of the Spanish ports on the continent; and of late imitate the French both in their dress and manners. The city is supplied with water by a small river called *Lagida*, which rises from the hills on the south-west side of the town, and divides itself into three streams, one of which falls into the sea on the east side of the town, but the other two flow through the place, entering the walls near the middle of the city.

As to the fortifications, it was already remarked, that the entrance to the harbour is by a narrow gut near half a mile in length: this passage is defended on the east side by a strong castle called *El Moro*, situated on a high rock; and on the walls and bastions are mounted 40 pieces of cannon. Under the faces of the south-west bastion of the Moro, and more within the entrance of the harbour, is a battery of stone called the *Twelve Apostles*, almost level with the water, and the guns of which carry each a ball of 36 pounds. A little higher, and opposite to the Point gate, is the *La Divina Pastora*, or the Shepherd's Battery, of 14 guns, level with the water. On the west side of the entrance, at the point, is a square fort called the *Punta*, with four bastions well mounted with cannon, about 200

Havanna. yards distant from the Punta gate of the town. On the bastions of the town, next the harbour, are a number of cannon; and about the middle of the city is another fort, called *El Fuerte*, a square fort with four bastions, mounted with 22 pieces of cannon, of no great strength; but in this last the governor resides, and in it the king of Spain's treasures are deposited till the arrival of the galleons. On the land-side, from the Punta gate to the dock-yard, there is a rampart with bastions, faced with stone, and earthen parapets with a ditch, which in several places has fallen in, and is almost filled up, particularly behind the Punta and land-gates, near the stone quarries, which, if joined to one another, might be of great detriment to the place in case of a siege, as a lodgement might be made in them. The ground here rises with an easy ascent to the land-gate; and is either open pasture or garden ground, well stored with the cabbage-tree. Before the land-gate is a ravelin. The hill on a rising ground from this gate (which is the highest part of the town) to the dock-yard, is steeper than on the other side.

Such are the fortifications of the Havanna, which are the best the Spaniards have in the West Indies, as indeed the place is of the greatest importance. But though strong, they have many defects, and from the situation of the town and forts, are commanded by many eminences, of which an enemy could not fail to take advantage. On the east side of the harbour, the Cavannas, on a part of which the Moro is built, commands in a great measure that fort, but absolutely commands the Punta, El Fuerte, and whole north-east part of the city, which is the best fortified. On the west side of the city runs a suburb, called *Guadaloupe*, whose church is situated on an eminence about half a mile from the land-gate, with which it is on a level, and higher than any other part of the fortifications. From the north side of this rising ground, the Punta gate may be flanked; and from the south-east side the dock yard is commanded. Along the north side runs an aqueduct, which falling into the ditch at the land-gate, runs down to the dock-yard, both for watering the ships and turning a saw-mill. About half a mile from the church, is a bridge made over a rivulet that runs into the bay about 100 yards. That road leads to the centre of the island, and extends to Baracoa, above 600 miles distant. From this bridge to the Lazaretto, is about two miles, with a rising ground betwixt them. A trench thrown up between these two places would cut off the communication with the town by land. From these observations it will plainly appear, that the Havanna, though well fortified, is not impregnable.

The Havanna has greatly contributed to the maritime strength of the crown of Spain, many ships having been built here within these few years, from 60 to 80 guns, the island furnishing the finest materials, such as oak, pine, cedar, and mahogany. The only defect of the harbour is the narrowness of its entry; for though free from bars and shoals, yet only one ship at a time can enter it; from which circumstance the galleons have more than once been insulted, and some of them taken, at the mouth of the harbour, the forts there not being able to afford them any assistance.

Upon the rupture with Spain in 1762, the British ministry sent a squadron and army against this place,

Havanna. under the command of Admiral Pocock and Lord Albemarle. The Spaniards had in the harbour at the time a fleet of twelve sail of the line, two of them but just launched, two more on the stocks nearly finished, and several merchant ships. The men of war were almost ready for sea; but no account had reached the governor of the intended attack. The place, however, was gallantly defended, and sustained a siege of two months and eight days before it could be reduced; when a capitulation was signed, and along with the city was yielded a district of 180 miles to the westward. This conquest was without doubt in itself the most considerable, and in its consequences the most decisive, of any we had made since the beginning of the war; and in no operation were the courage, steadiness, and perseverance of the British troops, and the conduct of their leaders, more conspicuous. The acquisition of this place united in itself all the advantages which can be acquired in war. It was a military achievement of the highest class. By its effect on the enemy's marine it was equal to the greatest naval victory, and in the plunder it equalled the produce of a national subsidy. Nine sail of the enemy's line-of-battle ships were taken; three of their capital ships had been sunk by themselves at the beginning of the siege; two more were in forwardness upon the stocks, and were afterwards destroyed by the captors. The enemy on this occasion lost a whole fleet of ships of war, besides a number of considerable merchant ships; and in ready money, in tobacco collected at the Havanna on account of the king of Spain, and in other valuable merchandises, the sum lost by the enemy perhaps did not fall short of three millions sterling.

The city of Havanna was restored by the peace of 1763; and is of the greatest importance to Spain, being the rendezvous for all their fleets to return from America to Europe, lying at the mouth of the gulf of Florida, through which they are all obliged to pass. Here the navy of Spain stationed in the West Indies ride; and here the galleons, the flota, and other merchant ships from other parts both of the continent and islands, meet in September, to take in provisions and water, with great part of their lading, and for the convenience of returning to Spain in a body. A continual fair is held till their departure, which generally happens before the end of the month, when proclamation is made, forbidding any person belonging to the fleet to stay in town on pain of death; and accordingly, on firing the warning gun, they all retire on board.—The commerce carried on in this port, which is very considerable; may be distinguished into the particular commerce of the island of Cuba, and that more general by the galleons and flota. The former consists in hides, usually styled of the Havanna, which are excellent, and of great value; sugar, tobacco, admirable in its kind, &c. Though strangers are prohibited to trade, yet a contraband commerce is carried on brisker here than at Vera Cruz. Some little trade is carried on by other ports of Cuba, but it is very inconsiderable. As to the general commerce, this port is the place of rendezvous (as already mentioned) for all ships, particularly from Carthagena, Puerto Velo, and La Vera Cruz, which return to Spain from the Indies. The Havanna is regularly supplied with European goods only by the register ships from Cadiz and the

Canaries. The flota and galleons bring there no more than the refuse of their cargoes, which they had not been able to dispose of at Carthagena, Puerto Velo, or La Vera Cruz. When the fleet is in the harbour, provisions are excessively dear on shore, and money so plenty, that a Spaniard expects half a piece of eight a-day from a male slave, and a quarter from a female, out of what they earn for their labour. The fleet generally sails from thence, through the channel of Bahama, in the month of September; and is the richest in the world; since, in silver and merchandise, there is seldom less than thirty millions of pieces of eight on board, or six millions seven hundred and fifty thousand pounds of our money.—It is natural to imagine, that a port of so much consequence as the Havanna ought to be well fortified. Since it has been restored to Spain, many new works have been added, to prevent if possible a similar disaster befalling it. W. Long. 82. 13. N. Lat. 23. 12.

HAVEL, a river of Brandenburg, which proceeds from a lake in the duchy of Mecklenburg, and running through the middle Marche, and through Brandenburg and other towns, runs north, and falls into the Elbe near Werben.

HAVELBERG, a town of Germany, in the circle of Lower Saxony, and in the electorate of Brandenburg, with a bishop's see, secularized in favour of the house of Brandenburg. It is seated on the river Havel, in E. Long. 12. 17. N. Lat. 52. 51.

HAVEN, a sea-port or harbour for ships. See **PORT** and **HARBOUR**. The word is derived from the Saxon *havene*, or the German *hafen*, or the French *havre*, which all signify the same thing.

HAVERCAMP, **SIGIBERT**, a celebrated Dutch scholar and critic, professor of history, eloquence, and the Greek tongue, at Leyden. He was particularly skilled in medals; and was the author of some esteemed works in that way, beside giving good and elegant editions of several Greek and Latin authors. He died at Leyden in 1742, aged 58.

HAVERFORD-WEST, a town of Pembroke-shire in South Wales, seated on the side of a hill, which forms a part of the west bank of the river Dongledye. It is an incorporated town and county of itself. The mayor of the town is admiral, coroner, coacheater, and clerk of the markets, within its precincts. Here the assizes are held and the county-jail kept. The town enjoys several privileges, and has its own courts. It was formerly fortified with a rampart and castle, which are now in ruins. Population 3093 in 1811. W. Long. 4. 58. N. Lat. 51. 45.

HAVERRILL, a town of England, in the county of Suffolk, where there is a considerable manufactory of checks, cottons, and fustians. By the ruins of a church and castle still to be seen, it appears to have been formerly a place of much greater consequence than at present. It had 248 houses, and about 1216 inhabitants, in 1811. E. Long. 0. 28. N. Lat. 52. 6.

HAUL, an expression peculiar to seamen, implying to pull a single rope, without the assistance of blocks or other such mechanical powers. When a rope is otherwise pulled, as by the application of tackles, or the connection with blocks, &c. the term is changed into *bowing*.

Havanna
Haul

Haul
Hauriant

To *HAUL the Wind*, is to direct the ship's course nearer to that point of the compass from which the wind arises. Thus, supposing a ship to sail south-west, with the wind northerly, and some particular occasion requires to haul the wind more westward; to perform this operation, it is necessary to arrange the sails more obliquely with her keel; to brace the yards more forward, by slackening the starboard and pulling in the larboard braces, and to haul the lower sheets further aft; and, finally, to put the helm a-port, i. e. over to the larboard side of the vessel. As soon as her head is turned directly to the westward, and her sails are trimmed accordingly, she is said to have hauled the wind four points; that is to say, from south-west to west. She may still go two points nearer to the direction of the wind, by disposing her sails according to their greatest obliquity, or, in the sea-phrase, by *trimming all sharp*; and in this situation she is said to be close-hauled, as sailing west-north-west.

HAUM, HALM, or *Hawn*, among farmers, denotes the stem or stalk of corn, pease, beans, &c. from the root to the ear.

HAUNCH, or HANCH, the *Hip*, or that part of the body between the ribs and the thigh.

The haunches of a horse are too long, if when standing in the stable, he limps, with his hind-legs farther back than he ought; and when the top or onset of his tail is not in a perpendicular line to the tip of his hocks, as it always does in horses whose haunches are of a just length. There are some horses which, though they have too long haunches, yet commonly walk well: such are good to climb hills, but are not at all sure upon a descent; for they cannot ply their hams, and never gallop slowly, but always nearly upon a full speed. The art of riding the great horse has not a more necessary lesson than that of putting a horse upon his haunches; which, in other words, is called *coupling him well*, or putting him well together, or compact. A horse that cannot bend or lower his haunches, throws himself too much upon his shoulder, and lies heavy upon the bridle.

HAVRE, in geography, &c. a French term signifying the same with haven or harbour.

HAVRE de Grace, a sea-port town of France, on the English channel, in a large plain at the mouth of the river Seine, and the department of the Lower Seine. It is a small fortified town, nearly of a square figure, divided into two parts by the harbour, surrounded with a wall and other works, and defended by a very strong citadel. It is one of the most important places in France, on account of its foreign trade and convenient harbour; for which reason it was made a distinct government from the rest of Normandy. Its inhabitants amount to 21,000. It was surprised in 1562 by the Protestants, who delivered it to Queen Elizabeth; but it was lost next year. In 1694 it was bombarded by the English, and also in the year 1748. E. Long. 0. 12. N. Lat. 49. 29.

HAVRE de Grace, a port town and port of entry in America, in the county of Harford, Maryland. It contains about 900 inhabitants, and lies about 65 miles south-west of Philadelphia. N. Lat. 39. 39.

HAUREANT, in *Heraklogy*, a term peculiar to fishes; and signifies their standing upright, as if they were refreshing themselves by sucking in the air.

Haute
Feuille
Hawker.

HAUTE FEUILLE; JOHN, an ingenious mechanic, was born at Orleans in 1647. Though he embraced the state of an ecclesiastic, and enjoyed several benefices, he applied almost his whole life to mechanics, in which he made a great progress. He had a particular taste for clock-work, and made several discoveries in it that were of singular use. He claimed the discovery of moderating the vibration of the balance in watches by means of a small steel-spring, which has since been made use of. This discovery he laid before the members of the Academy of Sciences in 1674; and these watches are, by way of eminence, called *pendulum-watches*; not that they have real pendulums, but because they nearly approach to the justness of pendulums. M. Huygens perfected this happy invention; but having declared himself the inventor, and obtained from Louis XIV. a patent for making watches with spiral springs, the Abbé Feuille opposed the registering of this privilege, and published a piece on the subject against M. Huygens. He wrote a great number of other pieces, most of which are small pamphlets consisting of a few pages, but very curious; as, 1. His perpetual pendulum, quarto. 2. New inventions, quarto. 3. The Art of Breathing under Water, and the means of preserving a Flame shut up in a small Place. 4. Reflections on Machines for raising Water. 5. His opinion on the different sentiments of Mallebranche and Regis relating to the appearance of the Moon when seen in the Horizon. 6. The Magnetic Balance. 7. A Planet to the King on the Longitude. 8. Letter on the Secret of the Longitude. 9. A new System on the Flux and Reflux of the Sea. 10. The Means of making sensible Experiments that prove the Motion of the Earth; and many other pieces. He died in 1724.

HAUTOBOY, a musical instrument of the wind kind, shaped much like the lute, only that it spreads and widens towards the bottom, and is sounded through a reed. The treble is two feet long; the tenor goes a fifth lower when blown open: it has only eight holes; but the bass, which is five feet long, has eleven.

The word is French, *haut bois*, q. d. "high wood;" and is given to this instrument because the tone of it is higher than that of the violin.

HAW, a sort of berry, the fruit of several species of mespilus, thence denominated *hawthorns*. See *MESPILUS*, BOTANY Index.

HAW, among farriers, an excrescence resembling a gristle, growing under the nether eyelid and eye of a horse, which, if not timely removed, destroys it. See *FARRIERY*.

HAW, a small parcel of land so called in Kent, as a *Hemphaw*, or *Beanhaw*, lying near the house, and inclosed for these uses. But Sir Edward Coke, in an ancient plea concerning Feversham in Kent, says *hawes are houses*.

Haw-Finch. See *LOXIA*, ORNITHOLOGY Index.

HAWGH, or HOWGH, signifies a green plot in a valley as it is used in the north of England.

HAWK. See *FALCO*, ORNITHOLOGY Index.

HAWKERS, anciently, were fraudulent persons, who went from place to place buying and selling brass, pewter, and other merchandise, which ought to be uttered in open market. In this sense the word is mentioned *anno 25 Hen. VIII. cap. 6. and 33 ejusdem*

Hawkers, Hawkesworth. cap. 4. The appellation *hawkers* seems to have risen from their uncertain wandering, like those who, with hawks, seek their game where they can find it.

The term is now used as synonymous with pedlar; a person who travels about the country selling wares. Every hawker must take out an annual license, for which he must pay 4l. and if he travels with a horse, ass, or mule, for every one of them 8l. If he travels without a license, or contrary to it, he forfeits for every offence to the informer, and to the poor of the parish where discovered, 10l. The acts relating to hawkers do not extend to makers of goods or their agents; or to those who sell goods in fairs or markets; to the sellers of fish, fruit, or other victuals; nor to the venders of books and newspapers, 9 and 10 W. cap. 27. 3 and 4 Anne, cap. 4. But hawkers shall not, by virtue of such license, sell or offer to sale any tea or spirituous liquors, though with a permit, under the penalty of having the same seized, and imprisonment and prosecution of the offender, 9 Geo. II. cap. 35. Hawkers who were licenced on June 23. 1785, may set up any business in the place where they are resident inhabitants, though not brought up thereto, and may employ therein persons who have not been apprentices.

HAWKERS, is a term also applied to those who go up and down London streets and country towns, selling newspapers, pamphlets, &c.

HAWKESWORTH, JOHN, a celebrated English writer, was born about the year 1719; though his epitaph, as we find it in the Gentleman's Magazine for August 1781, makes him to have been born in 1715. He was brought up to a mechanical profession, that of a watchmaker as is supposed. He was of the presbyterian persuasion, and a member of the celebrated Tom Bradbury's meeting, from which he was expelled for some irregularities. He afterwards devoted himself to literature, and became an author of considerable eminence. In the early part of life his circumstances were rather confined. He resided some time at Bromley in Kent, where his wife kept a boarding-school. He afterwards became known to a lady who had great property and interest in the East India Company, and through her means was chosen a director of that body. As an author, his *Adventurer* is his capital work; the merits of which, if we mistake not, procured him the degree of LL. D. from Herring archbishop of Canterbury. When the design of compiling a narrative of the discoveries in the South Seas was on foot, he was recommended as a proper person to be employed on the occasion: but in truth he was not a proper person, nor did the performance answer expectation. Works of taste and elegance, where imagination and the passions were to be affected, were his province; not works of dry, cold, accurate narrative. However, he executed his task, and is said to have received for it the enormous sum of 6000l. He died in 1773; some say of high living; others of chagrin from the ill reception of his *Narrative*: for he was a man of the keenest sensibility, and obnoxious to all the evils of such irritable natures. On a handsome marble monument erected to his memory at Bromley in Kent is an inscription, of which the following is a part taken from the last number of *The Adventurer*:

"The hour is hasting, in which whatever praise
"or censure I have acquired will be remembered
"with equal indifference. Time, who is impatient
"to date my last paper, will shortly moulder the
"hand which is now writing in the dust, and still
"the breast that now throbs at the reflection. But
"let not this be read as something that relates only
"to another; for a few years only can divide the
"eye that is now reading from the hand that has
"written."

HAWKING, the exercise of taking wild-fowl by means of hawks. The method of reclaiming, manning, and bringing up a hawk to this exercise, is called *falconry*. See **FALCONRY**.

There are only two countries in the world where we have any evidence that the exercise of hawking was very anciently in vogue. These are, Thrace and Britain. In the former, it was pursued merely as the diversion of a particular district, if we may believe Pliny*, whose account is rendered obscure by the darkness of his own ideas of the matter. The primitive Britons, with a fondness for the exercise of hunting, had also a taste for that of hawking; and every chief among them maintained a considerable number of birds for that sport. It appears also from a curious passage in the poems of Ossian†, that the same diversion was fashionable at a very early period in Scotland. The poet tells us, that a peace was endeavoured to be gained by the proffer of 100 managed steeds, 100 foreign captives, and "100 hawks with fluttering wings, that fly across the sky." To the Romans this diversion was scarce known in the days of Vespasian; yet it was introduced immediately afterwards. Most probably they adopted it from the Britons; but we certainly know that they greatly improved it by the introduction of spaniels into the island. In this state it appears among the Roman Britons in the sixth century. Gildas, in a remarkable passage in his first epistle, speaks of Maglocunus, on his relinquishing the sphere of ambition, and taking refuge in a monastery; and proverbially compares him to a dove, that hastens away at the noisy approach of the dogs, and with various turns and windings takes her flight from the talons of the hawk.

In after times, hawking was the principal amusement of the English: a person of rank scarce stirred out without his hawk on his hand; which, in old paintings, is the criterion of nobility. Harold, afterwards king of England, when he went on a most important embassy into Normandy, is painted embarking with a bird on his fist, and a dog under his arm: and in an ancient picture of the nuptials of Henry VI. a nobleman is represented in much the same manner; for in those days, *it was thought sufficient for a nobleman to winde their horn, and to carry their hawk fair, and leave study and learning to the children of mean people*. The former were the accomplishments of the times; Spenser makes his gallant Sir Tristram boast,

Ne is there hawk which mantleth her on perch,
Whether high tow'ring, or accoasting low,
But I the measure of her flight doe search,
And all her prey, and all her diet know.

Book vi. canto 2.

In

Hawking.

In short, this diversion was, among the old English, the pride of the rich, and the privilege of the poor; no rank of men seems to have been excluded the amusement: we learn from the book of St Alban's that every degree had its peculiar hawk, from the emperor down to the holy-water clerk. Vast was the expence that sometimes attended this sport. In the reign of James I. Sir Thomas Monson is said to have given 1000*l.* for a cast of hawks: we are not then to wonder at the rigour of the laws that tended to preserve a pleasure that was carried to such an extravagant pitch. In the 34th of Edward III. it was made felony to steal a hawk; to take its eggs, even in a person's own ground, was punishable with imprisonment for a year and a day, besides a fine at the king's pleasure: in Queen Elizabeth's reign, the imprisonment was reduced to three months; but the offender was to find security for his good behaviour for seven years, or lie in prison till he did. Such was the enviable state of the times of old England; during the whole day, the gentry were given to the fowls of the air and the beasts of the field; in the evening, they celebrated their exploits with the most abandoned and brutish sottishness; at the same time, the inferior ranks of people, by the most unjust and arbitrary laws, were liable to capital punishments, to fines, and loss of liberty, for destroying the most noxious of the feathered tribe.

According to Olearius, the diversion of hawking is more followed by the Tartars and Persians than ever it was in any part of Europe. *Il n'y avoit point de lutte* (says he) *qui n'eust son aigle ou son faucon.*

The falcons or hawks that were in use in these kingdoms, are now found to breed in Wales, and in North Britain and its isles. The peregrine falcon inhabits the rocks of Caernarvonshire. The same species, with the gyrfalcon, the gentil, and the goshawk, are found in Scotland, and the lanmer in Ireland.

We may here take notice, that the Norwegian breed was, in old times, in high esteem in England: they were thought bribes worthy a king. Geoffrey Fitz-pierre gave two good Norway hawks to King John, to obtain for his friend the liberty of exporting 100 cwt. of cheese; and Nicholas the Dane was to give the king a hawk every time he came into England, that he might have free liberty to traffic throughout the king's dominions.

They were also made the tenures that some of the nobility held their estates by, from the crown. Thus Sir John Stanley had a grant of the Isle of Man from Henry IV. to be held of the king, his heirs, and successors, by homage and the service of two falcons, payable on the day of his or their coronation. And Philip de Hastang held his manor of Combertown in Cambridgeshire, by the service of keeping the king's falcons.

Hawking, though an exercise now much disused among us, in comparison of what it anciently was, does yet furnish a great variety of significant terms, which still obtain in our language. Thus, the parts of a hawk have their proper names.—The legs, from the thigh to the foot, are called *arms*; the toes, the *patty singles*; the claws, the *pouuces*.—The wings are called the *sails*; the long feathers thereof, the *beams*; the two longest, the *principal feathers*; those next thereto, the *flags*.—The tail is called the *train*; the breast-feathers, the *mails*; those behind the thigh, the

Vol. X. Part I.

pendant feathers.—When the feathers are not yet full grown, she is said to be *unsummed*; when they are complete, she is *summed*.—The *crow*, or *crop*, is called the *gorge*.—The pipe next the fundament, where the faeces are drawn down, is called the *pannel*.—The slimy substance lying in the pannel, is called the *glut*.—The upper and crooked part of the bill, is called the *beak*; the nether part, the *clap*; the yellow part between the beak and the eyes, the *sear* or *sere*; the two small holes therein, the *nares*.

As to her furniture?—The leathers, with bells buttoned on her legs, are called *bewits*.—The leathern thong, whereby the falconer holds the hawk, is called the *lease* or *leash*; the little straps, by which the lease is fastened to the legs, *jessis*; and a line or packthread fastened to the lease, in disciplining her, a *creance*.—A cover for her head, to keep her in the dark, is called a *hood*; a large wide hood, open behind, to be worn at first, is called a *ruster hood*: To draw the strings, that the hood may be in readiness to be pulled off, is called *unstriking the hood*.—The blinding a hawk just taken, by running a thread through her eyelids, and thus drawing them over the eyes, to prepare her for being hooded, is called *seeling*.—A figure or resemblance of a fowl, made of leather and feathers, is called a *lure*.—Her resting-place, when off the falconer's fist, is called the *perch*.—The place where her meat is laid, is called the *hack*; and that wherein she is set, while her feathers fall and come again, the *mew*.

Something given a hawk, to cleanse and purge her gorge, is called *casting*.—Small feathers given her to make her cast, are called *plamage*.—Gravel given her to help to bring down her stomach, is called *rangle*: Her throwing up filth from the gorge after casting, is called *gleaming*.—The purging of her grease, &c. *enseaming*.—A being stuffed is called *gurgiting*.—The inserting a feather in her wing, in lieu of a broken one, is called *inaping*.—The giving her a leg, wing, or pinion of a fowl to pull at, is called *tiring*.—The neck of a bird the hawk preys on, is called the *inke*.—What the hawk leaves of her prey, is called the *pill* or *pelf*.

There are also proper terms for her several actions. —When she flutters with her wings, as if striving to get away, either from perch or fist, she is said to *bate*. —When standing too near they fight with each other, it is called *crabbing*.—When the young ones quiver, and shake their wings in obedience to the elder, it is called *courring*.—When she wipes her beak after feeding, she is said to *feak*.—When she sleeps, she is said to *jouk*.—From the time of exchanging her coat, till she turn white again, is called her *intermewing*.—Treading is called *cauwking*: When she stretches one of her wings after her legs, and then the other, it is called *mantling*.—Her dung is called *muting*: when she mutes a good way from her, she is said to *slice*; when she does it directly down, instead of jerking backwards, she is said to *slime*; and if it be in drops, it is called *dropping*.—When she as it were sneezes, it is called *sniting*.—When she raises and shakes herself, she is said to *rouse*.—When, after mantling, she crosses her wings together over her back, she is said to *warble*.

When a hawk seizes, she is said to *bind*.—When after seizing, she pull off the feathers, she is said to *plume*.—When she raises a fowl aloft, and at length descends,

P p

Hawking. descends with it to the ground, it is called *trussing*.—When, being aloft, she descends to strike her prey, it is called *stooping*.—When she flies out too far from the game, she is said to *rake*.—When, forsaking her proper game, she flies at pyes, crows, &c. that chance to cross her, it is called *check*.—When, missing the fowl, she betakes herself to the next check, she is said to *fly on head*.—The fowl or game she flies at is called the *quarry*.—The dead body of a fowl killed by the hawk, is called a *pelt*.—When she flies away with the quarry, she is said to *carry*.—When in stooping she turns two or three times on the wing, to recover herself ere she seizes, it is called *canceliering*.—When she hits the prey, yet does not truss it, it is called *ruff*.—The making a hawk tame and gentle, is called *reclaiming*.—The bringing her to endure company, *manning* her.—An old staunch hawk, used to fly and set example to a young one, is called a *make-hawk*.

The reclaiming, manning, and bringing up a hawk to the sport, is not easy to be brought to any precise set of rules.—It consists in a number of little practices and observances, calculated to familiarize the falconer to his bird, to procure the love thereof, &c. See the article FALCONRY.

When your hawk comes readily to the lure, a large pair of luring-bells are to be put upon her; and the more giddy-headed and apt to rake out your hawk is, the larger must the bells be. Having done this, and she being sharp-set, ride out in a fair morning, into some large field unencumbered with trees or wood, with your hawk on your fist; then having loosened her hood, whistle softly, to provoke her to fly; unhood her, and let her fly with her head into the wind; for by that means she will be the better able to get upon the wing, and will naturally climb upwards, flying a circle. After she has flown three or four turns, then lure her with your voice, casting the lure about your head, having first tied a pullet to it; and if your falcon come in and approach near you, cast out the lure into the wind, and if she stoop to it reward her.

You will often find, that when she flies from the fist, she will take stand on the ground: this is a fault which is very common with soar-falcons. To remedy this, fright her up with your wand; and when you have forced her to take a turn or two, take her down to the lure, and feed her. But if this does not do, then you must have in readiness a duck sealed, so that she may see no way but backwards, and that will make her mount the higher. Hold this duck in your hand, by one of the wings near the body; then lure with the voice to make the falcon turn her head; and when she is at a reasonable pitch, cast your duck up just under her; when, if she strike, stoop, or truss the duck, permit her to kill it, and reward her by giving her a reasonable gorge. After you have practised this two or three times, your hawk will leave the stand, and, delighted to be on the wing, will be very obedient.

It is not convenient, for the first or second time, to show your hawk a large fowl; for it frequently happens, that they escape from the hawk, and she, not recovering them, rakes after them: this gives the falconer trouble, and frequently occasions the loss of the hawk. But if she happens to pursue a fowl, and being unable to recover it, gives it over, and comes in again direct-

Hawking. ly, then cast out a sealed duck; and if she stoop and truss it across the wings, permit her to take her pleasure, rewarding her also with the heart, brains, tongue, and liver. But if you have not a quick duck, take her down with a dry lure, and let her plume a pullet and feed upon it. By this means a hawk will learn to give over a fowl that rakes out, and on hearing the falconer's lure, will make back again, and know the better how to hold in the head.

Some hawks have a disdainful coyness, proceeding from their being high fed: such a hawk must not be rewarded though she should kill: but you may give her leave to plume a little; and then taking a sheep's heart cold, or the leg of a pullet, when the hawk is busy in pluming, let either of them be conveyed into the body of the fowl, that it may savour of it; and when the hawk has eaten the heart, brains, and tongue of the fowl, take out what is inclosed, call her to your fist, and feed her with it: afterwards give her some of the feathers of the fowl's neck, to scour her, and make her cast.

If your hawk be a stately high-flying one, she ought not to take more than one flight in a morning; and if she be made for the river, let her not fly more than twice: when she is at the highest, take her down with your lure; and when she has plumed and broken the fowl a little, feed her, by which means you will keep her a high-flyer, and fond of the lure.

HAWKINS, SIR JOHN, a very industrious writer and valuable magistrate, was born at London in the year 1719, where his father was employed as a builder and surveyor. He received an education for the same profession, but afterwards a clerk to an attorney. His employment being chiefly copying, he improved his mind in knowledge by rising early, and had made very great advances by the time that his clerkship ended. He was soon after admitted as an attorney, and his taste for music made him become a member of the Academy of Ancient Music. Having attained a degree of celebrity by publishing the words of two sets of cantatas, the music of which was furnished by Mr Stanley, he was introduced to some valuable acquaintances who assisted him in carrying forward his professional views. In 1749 he was introduced as a member of a tavern club which had been instituted by Dr Samuel Johnson, and the connection thus formed between that great man and him was only dissolved by death. In 1753 he married a daughter of Peter Storer, Esq. by which he obtained a very handsome fortune; and this being augmented by the death of Mr Hawkins's brother, he laid aside the profession of an attorney, and lived as an independent gentleman. He afterwards became a justice of the peace for the county of Middlesex, and was both an active and useful magistrate. Being extremely fond of angling, he became the editor of Walton's Complete Angler, which he enriched with notes of his own and a life of the author, a work which has been frequently republished since.

His "Observations on the Highways" brought him a liberal share of public approbation, and it has served as a model for all the acts which have since been passed. In 1765 he was chosen chairman to the quarter-sessions, and in the year 1772 he obtained the honour of knighthood. Some of the notes to the edition of Shakespeare by Johnson.

Hawkins,
Hawsc.

Johnson and Steevens were furnished by Sir John, who for many years was engaged in writing the history of music, which he finished in 1776, in five vols. 4to. dedicated to his majesty. It abounds with curious and original information, and may be considered as a repository of many useful things not elsewhere to be met with. His valuable library was destroyed by fire, which interrupted his literary labours, but made no change on the tranquillity of his mind. In the year 1787 his life and works of Dr Samuel Johnson appeared in 11 vols. 8vo. This life is a garrulous miscellany of anecdote, in which the author frequently wanders from his subject; yet it contains many facts respecting that extraordinary man which his enthusiastic admirers could wish had been concealed. After this he prepared for the termination of his own life, which he perceived approaching, for he died in the month of May 1789, about 70 years of age.

HAWSE, or **HAUSE**, is generally understood to imply the situation of the cables before the ship's stem, when she is moored with two anchors out from forward, viz. one on the starboard, and the other on the larboard bow. Hence it is usual to say, *she has a clear hause, or a foul hause*. It also denotes any small distance *a-head* of a ship, or between her head and the anchors employed to ride her, as, "He has anchored in our hause, The brig fell athwart our hause," &c.

A ship is said to ride with a clear hause, when the cables are directed to their anchors, without lying athwart the stem; or crossing, or being twisted round each other by the ship's winding about, according to the change of the wind, tide, or current.

A foul hause, on the contrary, implies that the cables lie across the stem, or bear upon each other, so as to be rubbed and chafed by the motion of the vessel. The hause accordingly is foul, by having either a cross, an elbow, or a round turn. If the larboard cable, lying across the stem, points out on the starboard side, while the starboard cable at the same time grows out on the larboard side, there is a cross in the hause. If, after this, the ship, without returning to her former position, continues to wind about the same way, so as to perform an entire revolution, each of the cables will be twisted round the other, and then directed out from the opposite bow, forming what is called a round turn. An elbow is produced when the ship stops in the middle of that revolution, after having had a cross: or, in other words, if she rides with her head northward with a clear hause, and afterwards turns quite round so as to direct her head northward again, she will have an elbow.

HAWSE-Holes, certain cylindrical holes cut through the bows of a ship on each side of the stem, through which the cables pass in order to be drawn into or let out of the vessel as occasion requires. They are fortified on each side by the

HAWSE-Pieces, a name given to the foremost timbers of a ship, whose lower ends rest on the knuckle-timber, or the foremost of the cant-timbers. They are generally parallel to the stem, having their upper ends sometimes terminated by the lower part of the beak-head; and otherwise by the top of the bow, particularly in small ships and merchantmen.

HAWSER, a large rope which holds the middle degree between the *cable* and *tow-line*, in any ship whereto it belongs, being a size smaller than the former, and as much larger than the latter.

HAY, any kind of grass cut and dried for the food of cattle. See **AGRICULTURE Index**.

HAY, a town of Brecknockshire, in Wales, seated near the confluence of the rivers Wye and Dulas. It was a town of good note in the time of the Romans; it being then fortified with a castle and a wall, which were ruined in the rebellion of Owen Glendower. It is at present a pretty good town; and the market is large for corn, cattle, and provisions. W. Long. 0. 56. N. Lat. 52. 10.

HAYES, CHARLES, Esq. a very singular person, whose great erudition was so concealed by his modesty, that his name is known to very few, though his publications are many. He was born in 1678, and became distinguished in 1704 by a Treatise of Fluxions, folio; the only work to which he ever set his name. In 1710, came out a small 4to pamphlet of 19 pages, entitled, *A new and easy Method to find out the Longitude, from observing the Altitudes of the Celestial Bodies*: and in 1723, *The Moon, a Philosophical Dialogue*; tending to show, that the moon is not an opaque body, but has original light of her own. During a long course of years, the management of the late Royal African Company lay in a manner wholly upon Mr Hayes, he being annually either sub-governor or deputy-governor; notwithstanding which, he continued his pursuit after general knowledge. To a skill in the Greek and Latin as well as modern languages, he added the knowledge of the Hebrew: and published several pieces relating to the translation and chronology of the Scriptures. The African Company being dissolved in 1752, he retired to Down in Kent, where he gave himself up to study. May 1753, he began to compile in Latin his *Chronographia Asiatica et Egyptiaca*, which he lived to finish but not to publish; which, however, was published afterwards. August 1758, he left his house in Kent, and took chambers in Gray's-Inn, where he died, Dec. 18. 1760, in his 82d year. The title of his posthumous works runs thus: *Chronographia Asiatica et Egyptiaca Specimen; in quo, 1. Origo Chronologiae LXX Interpretum investigatur. 2. Conspectus totius operis exhibetur, 8vo.*

HAYNAULT. See **HAINAULT**.

HAYS, particular nets for taking rabbits, hares, &c. common to be bought in shops that sell nets, and they may be had larger or shorter as you think fit; from 15 to 20 fathoms is a good length, and for depth a fathom.

As rabbits often straggle abroad about mid-day for fresh grass, where you perceive a number gone forth to any remote brakes or thickets, pitch two or three of these hays about their burrows; lie close there: but in case you have not nets enough to inclose all their burrows, some may be stopped up with stones, &c. Then set out with the coney-dog to hunt up and down at a good distance, and draw on by degrees to the man who is with you, and lies close by the hay, who may take them as they bolt into it.

HAYWARD, the person who keeps the common herd or cattle of a town. He is appointed by the lord's court;

Hawser
Hayward.

Hayward
Hazel.

court; and his office is to see that the cattle neither break nor crop the hedges of inclosed grounds.

HAZAEEL, an officer belonging to Benhadad king of Syria, caused that prince to be put to death, and reigned in his stead. He defeated Joram, Jehu, and Jehoahaz, kings of Israel; and, after his death, was succeeded by Benhadad his son, 852 B. C.

HAZARD, or **CHANCE**, in gaming. See **GAMING**.

HAZARD, a game on dice, without tables, is very properly so called; since it speedily makes a man, or undoes him.

It is played with only two dice; and as many may play at it as can stand round the largest round table.

Two things are chiefly to be observed, viz. main and chance; the latter belonging to the caster, and the former, or main, to the other gamesters. There can be no main thrown above nine, nor under five; so that five, six, seven, eight, and nine, are the only mains flung at hazard. Chances and nicks are from four to ten: thus four is a chance to nine, five to eight, six to seven, seven to six, eight to five; and nine and ten a chance to five, six, seven, and eight: in short, four, five, six, seven, eight, nine, and ten, are chances to any main, if any of these nick it not. Now nicks are either when the chance is the same with the main, as five and five, or the like; or six and twelve, seven and eleven, eight and twelve. Here observe, that twelve is out to nine, seven, and five; eleven is out to nine, eight, six, and five; and ames-ace and duce-ace, are out to all mains whatever.

HAZLE, or **HAZEL**. See **CORYLUS**, **BOTANY Index**.

The kernels of the fruit have a mild, farinaceous, oily taste, agreeable to most palates. Squirrels and mice are fond of them, as well as some birds, such as jays, nutcrackers, &c. A kind of chocolate has been prepared from them, and there are instances of their having been formed into bread. The oil expressed from them is little inferior to the oil of almonds; and is used by painters and by chemists for receiving and retaining odours. The charcoal made of the wood is used by painters in drawing.—Some of the Highlanders, where superstition has not totally subsided, look upon the tree itself as unlucky; but are glad to get two of the nuts naturally conjoined, which is a good omen. These they call *eno-chomblaich*, and carry them as an efficacious charm against witchcraft.

Evelyn tells us, that no plant is more proper for thickening of copses than the hazle, for which he directs the following expeditious method. Take a pole of hazle (ash or poplar may also be used) of 20 or 30 feet in length, the head a little lopped into the ground, giving it a chop near the ground to make it succumb; this fastened to the earth with a hook or two, and covered with some fresh mould at a competent depth (as gardeners lay their carnations), will produce a great number of suckers, and thicken and furnish a copse speedily.

HAZLE Earth, or **Hazley Earth**, a kind of red loam, which is said to be an excellent mixture with other sorts of earth; uniting what is too loose, cooling what is too hot, and gently retaining the moisture.

Witch-HAZLE. See **HAMAMELIS**.

HEAD, the uppermost or foremost part of the body of an animal. See **ANATOMY Index**.

HEAD-Ach, a most troublesome sensation in the head, produced by various causes, and attended with different symptoms, according to its different degrees and the place where it is seated. See **MEDICINE Index**.

Dragon's HEAD, in **Astronomy**, is the ascending node of the moon or other planet.

HEAD of a Ship, an ornamental figure erected on the continuation of a ship's stem, as being expressive of her name, and emblematical of war, navigation, commerce, &c.

HEAD, is also used in a more enlarged sense to signify the whole front or fore part of the ship, including the bows on each side: the head therefore opens the column of water through which the ship passes when advancing. Hence we say, head-sails, head-stea, head-way, &c.

Thus, fig. 1. Plate CCL represents one side of the fore part or head of a 74 gun ship, together with part of the bow, keel, and gunnel. The names of the several pieces, exhibited therein, are as follow:

AA Fore part of the keel, with *aa* the two false keels beneath it.

AC The stem.

aa The cat-head.

bb The supporter of the cat-head.

cc The knight-head, or bollard-timber, of which there is one on each side; to secure the inner end of the bowsprit.

dd The hause-holes.

ee The naval-hoods, i. e. thick pieces of plank laid upon the bow to strengthen the edges of the hause-holes.

f The davit-chock, by which the davit is firmly wedged while employed to fish the anchor.

g The bulk-head, which terminates the fore-castle on the fore side, being called the *beak-head*, *bulk-head*, by shipwrights.

H The gun-ports of the lower deck.

A The gun-ports of the upper deck and fore-castle.

I, I, The channel, with their dead-eyes and chain-plates.

i The gripe, or fore foot, which unites the keel with the stem, forming a part of either.

kk These dotted lines represent the thickness and descent of the different decks from the fore-part of the ship towards the middle. The lowest of the three dotted lines *l* expresses the convexity of the beams, or the difference between the height of the deck in the middle of its breadth and at the ship's side. This is also exhibited more clearly in the **MIDSHIP-FRAME**; where the red curve of the beam is delineated. N. B. These lines must be always parallel to the lines which terminate the gun-ports above and below.

mm The timbers of the head, and part of the bowsprit.

X The rails of the head which lie across the timbers.

QZ Fore part of the main-wale.

RK Fore part of the channel-wale.

UC The lead water-line.

Fig. 2. represents a head-view of a ship, with the projection

Head.

Plate
CCL.
fig. 1.

HARMONICA.

HARPS.

PLATE CCL.

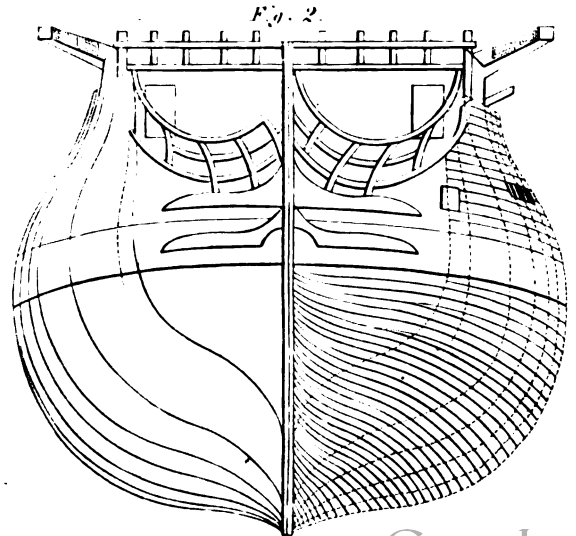
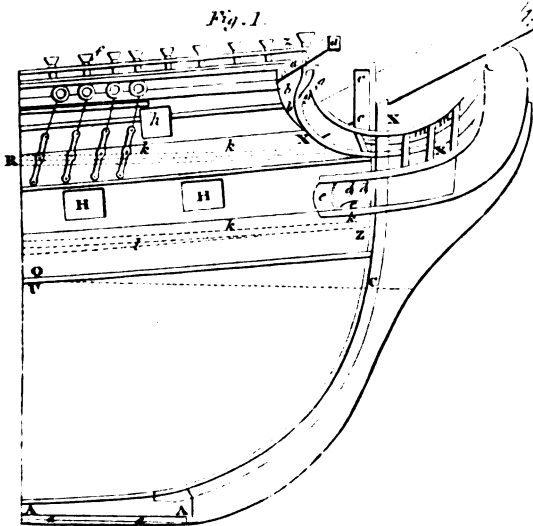
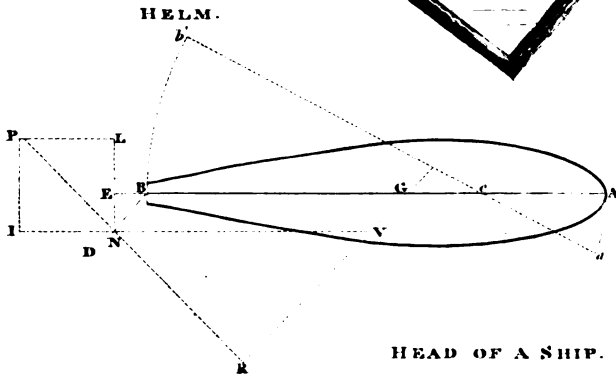
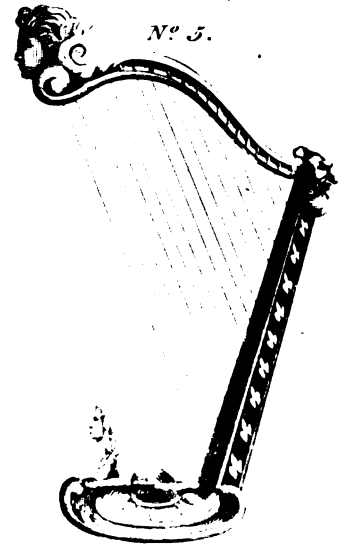
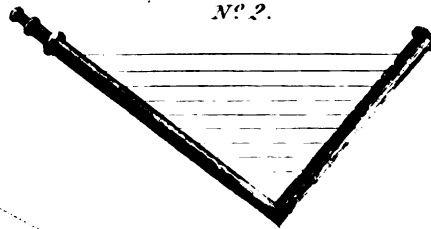
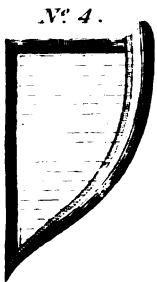
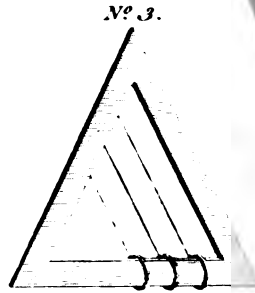
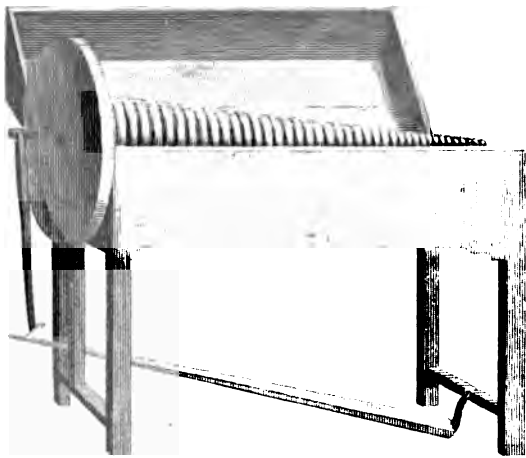

A. Wilson Sculp

Head: projection of her principal timber and all her planks laid on one side.

It is evident that the fore part of a ship is called its *head*, from the affinity of motion and position it bears to a fish, and in general to the horizontal situation of all animals whilst swimming.

By the HEAD; the state of a ship, which is laden deeper at the fore end than the after end.

HEAD-Borow, or *HEAD-Borough*, signifies the person who is the chief of the frank pledge, and had anciently the principal direction of those within his own pledge. He was also called *burrow-head*, *burshoulder*, now *bors-holder*, *third-borrow*, *tything-man*, *chief-pledgr*, and *borow-elder*, according to the diversity of speech in different places. This officer is now usually called a *high constable*. The head-borow was the chief of ten pledges: the other nine were called *hand-borows*, or *plegii manuales*, &c.

HEAD-Mould-shot, a disease in children, wherein the sutures of the skull, generally the coronal, *ride*; that is, have their edges shot one over another; and are so close locked together, as to compress the internal parts, the meninges, or even the brain itself. The disease usually occasions convulsions, and is supposed to admit of no cure from medicine, unless room could be given by manual operation or a division of the sutures.

The head-mould-shot is the disorder opposite to the horse-shoe head.

HEAD-Pence, an exaction of a certain sum formerly collected by the sheriff of Northumberland from the inhabitants of that county, without any account to be made to the king. This was abolished by the statute 23 Henry VI. cap. 7.

HEAD-Tin, in *Metallurgy*, is a preparation of tin-ore toward the fitting it for working into metal. When the ore has been pounded and twice washed, that part of it which lies uppermost, or makes the surface of the mass in the tub, is called the *head-tin*; this is separated from the rest, and after a little more washing becomes fit for the *blowing-house*.

HEAD-Fast, a rope employed to fasten a ship to a wharf, chain, or buoy, or to some other vessel alongside.

HEAD-Land, a name frequently given to a cape or promontory.

HEAD-Dress, among the Jewish, Grecian, and Roman ladies, as among ourselves, was various, according to the different periods of time, and the fluctuation of fashion. In general, it principally consisted of their hair differently tricked out. It was usually divided before with a bodkin, into two equal parts; sometimes it was covered with a net, or put into a kind of purse, or tied behind in the form of a knot, or bound back and plaited with ribbands. It was washed with great care; essence and perfumes were applied to it, and gold dust sometimes made use of as powder. Pearls and jewels made a part of their ornaments; and pendants worn in the ear. To cover the defect of hair, perukes were made use of by the gentlemen of Rome. And we read that Otho had a covering of false hair, because he had not much of his own. See *HAIR* and *JEWELS*.

Both Grecian and Roman ladies wore *têtes*. But whether they ever built up their heads so high as the

English or our continental neighbours, will admit of a dispute.

HEADMOST, the situation of any ship or ships which are the most advanced in a fleet, or line of battle.

HEAD-Rope, that part of the bolt-rope which terminates any of the principal sails on the upper edge, which is accordingly sewed thereto. See the article *BOLT-ROPE*.

HEAD-Sails, a general name for all those sails which are extended on the foremast and bowsprit, and employed to command the fore part of the ship: such are the foresail, fore-top-sail, fore-top-gallant-sail, jib, forestay-sail, and the spritsail, with its topsail. This term is used in opposition to *after-sails*, viz. all those which are extended on the mizen-mast, and on the stays between the mizen and main-masts.

HEAD-to-wind; the situation of a ship or boat, when her head is turned to windward.

HEAD-Way, the motion of advancing at sea. It is generally used when a ship first begins to advance; or when it is doubtful whether she is in a state of rest or motion. It is in both senses opposed to retreating, or moving with the stern foremost. See the article *STERN-WAY*.

HEALFANG, *HEALSFANG*, or *HALSFANG*, in our ancient customs, signifies *collistrigium* or the punishment of the pillory. The word is compounded of two Saxon words; *halp*, "neck," and *pangen*, "to contain:" *Pœnis scilicet qua dicitur collum stringatur*. The *healfang*, however, cannot signify a pillory in the charter of Canutus, De Forestis, cap. xiv. *Et pro culpa solvat regi duos solidos, quos Dani vocant halfehang*.

HEALFANG is also taken for a pecuniary punishment or mulct to commute for standing in the pillory; and is to be paid either to the king or the chief lord. *Qui falsum testimonium dedit, reddat regi vel terræ domino healfang*.

HEALING, in its general sense, includes the whole process of curing or removing a disorder, and recovering health. In this sense medicine is defined the art of healing. In its more restrained sense, as used in surgery, &c. healing denotes the uniting or consolidating the lips of a wound or ulcer. The medicines proper for this intention are called *incarnatives*, *agglutinatives*, *vulneraries*, &c.

HEALING, in *Architecture*, denotes the covering the roof of a building. The healing is various; as of lead, tiles, slate, Horsham stone, shingles, or reeds and straw.

HEALTH, is a right disposition of the body, and of all its parts; consisting in a due temperature, a right conformation, just connexion, and ready and free exercise of the several vital functions.

Health admits of latitude, as not being the same in all subjects, who may yet be said to enjoy health.

That part of medicine which shows the means of preserving health, is termed *hygiene*. See *MEDICINE Indes*.

The Greeks and Romans deified Health, representing it under the figure of a woman, whom they supposed to be the daughter of Æsculapius. We find the name of the goddess *Salus*, or Health, on many medals of the Roman emperors, with different inscriptions;

Head
Health

Health
||
Heart.

as, SALUS PUBLICA, SALUS REIPUBLICÆ, SALUS AUGUSTI, &c.

Methods of preserving the HEALTH of Mariners.
See MARINER.

HEAM, in beasts, denotes the same with *after-birth* in women. Thyme, pennyroyal, winter-savory, and common hore-bound, boiled in white wine, and given to a mare, are esteemed good to expel the heam. Dittany, applied in a pessary, expels the heam, as well as the dead foal; so also do fennel, hops, savin, angelica, &c.

HEARING, the act or faculty of perceiving sounds. Hearing is reckoned among our external senses. Its organ is the ear, and particularly the auditory nerve diffused through the same; and its object, certain motions or vibrations of the air. Hence hearing may be more scientifically defined a sensation, whereby, from a due motion impressed on the fibrillæ of the auditory nerve, and communicated thence to the sensory, the mind perceives and gets the idea of sounds. See ANATOMY, N^o 141.

HEARSE, among hunters, a hind in the second year of her age. See HUNTING.

HEARSE is the name of a well-known carriage, used for conveying the dead to the grave. The word is also used by Shakespeare in his *Henry VI.* for a monument erected over a grave.

HEART, in *Anatomy*, a muscular part of the animal body, situated in the thorax, on the anterior part of the diaphragm, between the two laminæ of the mediastinum, wherein the veins all terminate, and from which all the arteries arise; and which, by its alternate contraction and dilatation, is the chief instrument of the circulation of the blood, and the principle of life. See ANATOMY, N^o 121, 122.

Several ingenious persons have from time to time attempted to make estimates of the force of the blood in the heart and arteries; who have as widely differed from each other, as they have from the truth, for want of a sufficient number of data to argue upon. This set the truly ingenious Dr Hales upon making proper experiments, in order to ascertain the force of the blood in the veins and arteries of several animals.

Heart.

If, according to Dr Keil's estimate, the left ventricle of a man's heart throws out in each systole an ounce or 1.638 cubic inches of blood, and the area of the orifice of the aorta be = 0.4187, then dividing the former by this, the quotient 3.9 is the length of the cylinder of blood which is formed in passing through the aorta in each systole of the ventricle; and in the 75 pulses of a minute, a cylinder of 292.5 inches in length will pass: this is at the rate of 1462 feet in an hour. But the systole of the heart being performed in one-third of this time, the velocity of the blood in that instant will be thrice as much, viz. at the rate of 4386 feet in an hour, or 73 feet in a minute. And if the ventricle throws out one ounce in a pulse, then in the 75 pulses of a minute, the quantity of blood will be equal to 4.4lb. 11 oz. and, in 34 minutes, a quantity equal to a middle-sized man, viz. 158 lb. will pass through the heart. But if, with Dr Harvey and Dr Lower, we suppose two ounces of blood, that is, 3.276 cubic inches, to be thrown out at each systole of the ventricle, then the velocity of the blood in entering the orifice of the aorta will be double the former, viz. at the rate of 146 feet in a minute, and a quantity of blood equal to the weight of a man's body will pass in half the time, viz. 17 minutes.

If we suppose, what is probable, that the blood will rise $7\frac{1}{4}$ feet high in a tube fixed to the carotid artery of a man, and that the inward area of the left ventricle of his heart is equal to 15 square inches; these multiplied into $7\frac{1}{4}$ feet, give 1350 cubic inches of blood, which presses on that ventricle, when it first begins to contract, a weight equal to 15.5 pounds.

What the doctor thus calculates, from supposition, with regard to mankind, he actually experimented upon horses, dogs, fallow-does, &c. by fixing tubes in orifices opened in their veins and arteries; by observing the several heights to which the blood rose in these tubes, as they lay on the ground; and by measuring the capacities of the ventricles of the heart and orifices of the arteries. And, that the reader may the more readily compare the said estimates together, he has given a table of them, ranged in the following order.

Heart
Heat.

Heat.

The several animals.	Weight of each.	Height of the blood in the tube from the jugular vein.	Height of the blood in tubes fixed to arteries.	Capacity of the left ventricle of the heart.	Area of the orifice of the aorta.	Velocity of the blood in the aorta.	Quantities of blood equal to the weight of the animal, in what time.	How much in a minute.	Weight of the blood sustained by the left ventricle contracting.	N ^o of pulses in a minute.	Area of transverse section of descending aorta.	Area of the transverse section of ascending aorta.
	Pounds. Ounces.	Inches.	Feet. Inches.	Cubic inches	Square inches.	Feet and inches in a minute.	Minutes.	Pounds.	Pounds.		Square inches.	Square inches.
Man	160	On straining.	7 6	1.659	0.4187	56.55	34.18	4.38	51.5	75		
Horse 1st			8 3	3.318		113.3	17.5	9.36				
2d			9 8									
3d	825	12 52	9 6	10	1.036	86.85	60	13.75	113.22	86	0.677	0.369
Ox	1600			12.5	1.539	76.95	88	18.14		38	0.912	0.84
Sheep		5 1/2	9 6	5 1/2	1.172	174.5	20	4.593	36.56	65	0.094	0.07
Doe	91		4 2	9	0.476						0.383	0.246
Dogs 1st	52	0 6	6 8	1.172	0.196	144.77	11.9	4.34	33.61	97	0.106	0.041
2d	24	5 7	2 8	1	0.185	130.9	6.48	3.7			0.102	0.031
3d	18	5 4	4 8	0.633	0.118	130	7.8	2.3	19.8		0.07	0.022
4th	12 8	4 3	3 3	0.5	0.101	120	6.7	1.85	11.1		0.061	0.015

HEART-BURN, a disease usually called *cardialgia* by physicians. In surfeits, or upon swallowing without due mastication; when meats are eaten tough and fat, or with farinaceous substances unfermented; or when by any accident the saliva is vitiated, too scanty, or not intimately mixed with the food, the fermentation becomes tumultuous, the stomach swells with air, and this extraordinary commotion being attended with an unusual heat, brings on the uneasiness called the *heart-burn*; which is remedied by whatever promotes a greater secretion of saliva, or helps to mix it with our aliment. The testaceous powders, as oyster-shells, crabs-eyes, chalk, &c. are the usual remedies for the heart-burn.

HEARTH, that part of the pavement of a room on which the fire is immediately placed.

HEARTH-Money. See *CHIMNEY-Money*.

HEAT, in *Physiology*, has a double meaning; being put either for that peculiar sensation which is felt on the approach of burning bodies, or for the cause of that sensation; in which last sense it is synonymous with **FIRE**. This mode of speaking, however, is inaccurate; and, by confounding the effect with the cause, sometimes produces obscurity: it were to be wished, therefore, that the word *heat* was used only to denote the effect; and *fire*, or some other term, to denote the cause of that effect.

The disputes which formerly were so much agitated in the learned world concerning the nature of heat,

viz. whether it consisted merely in the motion of the terrestrial particles of bodies, or in that of a subtle fluid, are now mostly ceased, and it is almost universally believed to be the effect of a fluid. See **CHEMISTRY Index**.

HEAT of Burning Bodies.

HEAT of Chemical Mixtures.

Method of Measuring HEAT. See **THERMOMETER** and **PYROMETER**, **CHEMISTRY Index**.

Degrees of HEAT which Animals are capable of bearing.—The ancients were of opinion, that all countries lying within the tropics were uninhabitable by reason of their heat: but time has discovered their mistake; and it is now found, that no part of the world is too hot for mankind to live in. The learned Professor Boerhaave, in his chemistry, relates certain experiments made with great accuracy by the celebrated Fahrenheit, and others, at his desire, on this subject, in a sugar-baker's office; where the heat, at the time of making the experiments, was up to 146 degrees of Fahrenheit's thermometer. A sparrow, subjected to air thus heated, died, after breathing very laboriously, in less than seven minutes. A cat resisted this great heat somewhat above a quarter of an hour; and a dog about 28 minutes, discharging before his death a considerable quantity of a ruddy coloured foam, and exhaled a stench so peculiarly offensive, as to throw one of the assistants into a fainting fit. This dissolution of the humours, or great change from a natural state, the professor

Heat. professor attributes not to the heat of the stove alone, which would not have produced any such effect on the flesh of a dead animal; but likewise to the vital motion, by which a still greater degree of heat, he supposes, was produced in the fluids circulating through the lungs, in consequence of which the oils, salts, and spirits of the animal became so highly exalted.

Messieurs Du Hamel and Tillet having been sent into the province of Augmois, in the years 1760 and 1761, with a view of endeavouring to destroy an insect which consumed the grain of that province, effected the same in the manner related in the Memoirs for 1761, by exposing the affected corn, with the insects included in it, in an oven, where the heat was sufficient to kill them without injuring the grain. This operation was performed at Rochefoucault, in a large public oven, where, for economical views, their first step was to assure themselves of the heat remaining in it on the day after bread had been baked in it. This they did, by conveying in a thermometer on the end of a shovel, which, on its being withdrawn, indicated a degree of heat considerably above that of boiling water; but M. Tillet, convinced that the thermometer had fallen several degrees in drawing to the mouth of the oven, and appearing under some embarrassment on that head, a girl, one of the attendants on the oven, offered to enter, and mark with a pencil the height at which the thermometer stood within the oven. The girl smiled on M. Tillet's appearing to hesitate at this strange proposition; and entering the oven, with a pencil given her for that purpose, marked the thermometer, after staying two or three minutes, standing at 100 degrees of Reaumur's scale, or, to make use of a scale better known in this country, at near 260 degrees of Fahrenheit's. M. Tillet began to express an anxiety for the welfare of his female assistant, and to press her return. This female salamander, however, assuring him that she felt no inconvenience from her situation, remained there 10 minutes longer; that is, near the time when Boerhaave's oat parted with her nine lives under a much less degree of heat; when the thermometer standing at 288 degrees, or 76 degrees above that of boiling water, she came out of the oven, her complexion indeed considerably heightened, but her respiration by no means quick or laborious. After M. Tillet's return to Paris, these experiments were repeated by Mons. Marantin, commissaire de guerre, at Rochefoucault, an intelligent and accurate observer, on a second girl belonging to the oven, who remained in it, without much inconvenience, under the same degree of heat, as long as her predecessor; and even breathed an air heated to about 325 degrees for the space of five minutes.

M. Tillet endeavoured to clear up the very apparent contrariety between these experiments and those made under the direction of Boerhaave, by subjecting various animals, under different circumstances, to great degrees of heat. From his experiments, in some of which the animals were swaddled with clothes, and were thereby enabled to resist for a much longer time the

effects of the extraordinary heat, he infers, that the heat of the air received into the lungs was not, as was supposed by Boerhaave, the only or principal cause of the anxiety, laborious breathing, and death, of the animals on whom his experiments were made; but that the hot air, which had free and immediate access to every part of the surface of their bodies, penetrated the substance on all sides, and brought on a fever, from whence proceeded all the symptoms; on the contrary, the girls at Rochefoucault, having their bodies in great measure protected from this action by their clothes, were enabled to breathe the air, thus violently heated, for a long time without great inconvenience. In fact, we should think too, that the bulk of their bodies, though not thought of much consequence by M. Tillet, appears to have contributed not a little to their security. In common respiration, the blood, in its passage through the lungs, is cooled by being brought into contact with the external inspired air. In the present experiments, on the contrary, the vesicles and vessels of the lungs receiving at each inspiration an air heated to 300 degrees, must have been continually cooled and refreshed, as well as the subcutaneous vessels, by the successive arrival of the whole mass of blood contained in the interior parts of the body, whose heat might be supposed at the beginning of the experiment not to exceed 100 degrees. Not to mention, that M. Tillet's two girls may not possibly have been subjected to so great a degree of heat as that indicated by the thermometer; which appears to us to have always remained on the shovel, in contact with the earth.

These experiments soon excited other philosophers to make similar ones, of which some very remarkable ones are those of Dr Dobson at Liverpool, who gives the following account of them in the Philosophical Transactions, vol. lxx.

" I. The sweating-room of our public hospital at Liverpool, which is nearly a cube of nine feet, lighted from the top, was heated till the quicksilver stood at 224° on Fahrenheit's scale, nor would the tube of the thermometer indeed admit the heat to be raised higher. The thermometer was suspended by a string fixed to the wooden frame of the sky-light, and hung down about the centre of the room. Myself and several others were at this time inclosed in the stove, without experiencing any oppressive or painful sensation of heat proportioned to the degree pointed out by the thermometer. Every metallic substance about us soon became very hot.

" II. My friend Mr Park, an ingenious surgeon of this place, went into the stove heated to 202°. After ten minutes, I found the pulse quickened to 120. And to determine the increase of the animal heat, another thermometer was handed to him, in which the quicksilver already stood at 98°; but it rose only to 99½, whether the bulb of the thermometer was inclosed in the palms of the hands or received in the mouth (A). The natural state of this gentleman's pulse is about 65.

" III. Another gentleman went through the same experiment

(A) The scale of the thermometer, which was suspended by the string about the middle of the room, was of metal;

Heat. experiment in the same circumstances, and with the same effects.

"IV. One of the porters to the hospital, a healthy young man, and the pulse 75, was inclosed in the stove when the quicksilver stood at 210°; and he remained there, with little inconvenience, for 20 minutes. The pulse, now 164, and the animal heat, determined by another thermometer as in the former experiments, was 101½.

"V. A young gentleman of a delicate and irritable habit, whose natural pulse is about 80, remained in the stove ten minutes when heated to 224°. The pulse rose to 145, and the animal heat to 102°. This gentleman, who had been frequently in the stove during the course of the day, found himself feeble, and disposed to break out into sweats for 24 hours after the experiment.

"VI. Two small tin vessels, containing each the white of an egg, were put into the stove heated to 224°. One of them was placed on a wooden seat near the wall, and the other suspended by a string about the middle of the stove. After ten minutes, they began to coagulate; but the coagulation was sensibly quicker and firmer in that which was suspended, than in that which was placed on the wooden seat. The progress of the coagulation was as follows: it was first formed on the sides, and gradually extended itself; the whole of the bottom was next coagulated; and last of all, the middle part of the top.

"VII. Part of the shell of an egg was peeled away, leaving only the film which surrounds the white; and part of the white being drawn out, the film sunk so as to form a little cup. This cup was filled with some of the *albumen ovi*, which was consequently detached as much as possible from every thing but the cup. The lower part of the egg stood upon some light tow in a common gallipot, and was placed on the wooden seat in the stove. The quicksilver in the thermometer still continued at 224°. After remaining in the stove for an hour, the lower part of the egg which was covered with the shell was firmly coagulated, but that which was in the little cup was fluid and transparent. At the end of another hour it was still fluid, except on the edges where it was thinnest; and here it was still transparent; a sufficient proof that it was dried, not coagulated.

"VIII. A piece of bees-wax, placed in the same situation with the *albumen ovi* of the preceding experiment, and exposed to the same degree of heat in the stove, began to melt in five minutes: another piece suspended by a string, and a third piece put into the tin vessel and suspended, began likewise to liquefy in five minutes.

Even these experiments, though more accurate than the former, do not show the utmost degrees of heat which the human body is capable of enduring. Some others, still more remarkable (as in them the body was exposed to the heat without clothes),

by Drs Fordyce and Blagden, are also recorded in the Philosophical Transactions. They were made in rooms heated by flues in the floor, and by pouring upon it boiling water. There was no chimney in them, or any vent for the air, excepting through crevices at the door. In the first room were placed three thermometers, one in the hottest part of it, another in the coolest part, and a third on the table, to be used occasionally in the course of the experiment. Of these experiments, the two following may be taken as a specimen.

"About three hours after breakfast, Dr Fordyce having taken off all his clothes, except his shirt, and being furnished with wooden shoes tied on with list, went into one of the rooms, where he staid five minutes in a heat of 90°, and begun to sweat gently. He then entered another room, and stood in a part of it heated to 110°. In about half a minute his shirt became so wet that he was obliged to throw it aside, and then the water poured down in streams over his whole body. Having remained in this heat for ten minutes, he removed to a part of the room heated to 120°; and after staying there 20 minutes, found that the thermometer placed under his tongue, and held in his hand, stood just at 100°, and that his urine was of the same temperature. His pulse had gradually risen to 145 pulsations in a minute. The external circulation was greatly increased, the veins had become very large, and an universal redness had diffused itself all over the body, attended with a strong feeling of heat; his respiration, however, was little affected. He concluded this experiment by plunging in water heated to 100°; and after being wiped dry, was carried home in a chair; but the circulation did not subside for two hours.

"Dr Blagden took off his coat, waistcoat, and shirt, and went into one of the rooms, as soon as the thermometer had indicated a degree of heat above that of boiling water. The first impression of this hot air upon his body was exceedingly disagreeable, but in a few minutes all his uneasiness was removed by the breaking out of a sweat. At the end of 12 minutes he left the room very much fatigued, but no otherwise disordered. His pulse beat 136 in a minute, and the thermometer had risen to 220 degrees.

In others of these experiments it was found, that a heat even of 260° of Fahrenheit's thermometer could be submitted to with tolerable ease. But it must be observed, that in these great heats every piece of metal they carried about with them became intolerably hot. Small quantities of water placed in metalline vessels quickly boiled; but in a common earthen vessel it required an hour and a half to arrive at a temperature of 140°, nor could it ever be brought near the boiling point. Neither durst the people, who with impunity breathed the air of this very hot room at 264 degrees, bear to put their fingers into the boiling water, which indicated only a heat of 212°. So far from

metal; this was the only one I could then procure on which the degrees ran so high as to give any scope to the experiment. The scale of the other thermometer, which was employed for ascertaining the variations in the animal heat, was of ivory.

Heat.

from this, they could not bear the touch of quick-silver heated only to 120°, and could but just bear spirit of wine at 130°.

Animal HEAT. Of this there are various degrees; some animals preserving a heat of 100° or more in all the different temperatures of the atmosphere; others keep only a few degrees warmer than the medium which surrounds them; and in some of the more imperfect animals, the heat is scarcely one degree above the air or water in which they live.

The phenomenon of animal heat hath, from the earliest ages, been the subject of philosophical discussion; and, like most other subjects of this nature, its cause is not yet ascertained. The best treatises that have appeared on the subject, are those of Dr Duguid Leslie, published in 1778; and Mr Adair Crawford, in 1779. From the first of these performances, the following account of the different opinions on this subject is extracted.

“The ancients possessed not the requisites for minutely investigating the science of nature; and, prone to superstition, attributed every phenomenon which eluded their investigation to the influence of a supernatural power. Hippocrates, the father and founder of medicine, accounted animal heat a mystery, and bestowed on it many attributes of the Deity. In treating of that subject, he says in express terms, “what we call heat, appears to me to be something immortal, which understands, sees, hears, and knows every thing present and to come.”—Aristotle seems to have considered the subject particularly, but nothing is to be met with in his works that can be said to throw light upon it.—Galen tells us that the dispute between the philosophers and physicians of his time was, “whether animal heat depended on the motion of the heart and arteries; or whether, as the motion of the heart and arteries was innate, the heat was not also innate.” Both these opinions, however, he rejects; and attempts a solution of the question on his favourite system, namely, the peripatetic philosophy; but his leading principles being erroneous, his deductions are, of course, inadmissible.

“To enter into a minute detail of all the opinions offered by the moderns on the cause of animal heat, would far exceed our limits. Most of them, however, may be referred to one or other of the three general causes of heat, viz. mixture, fermentation, and mechanical means, or friction. See CHEMISTRY *Index*.”

Internal HEAT of the Earth. It was formerly supposed that the heat of the earth increased in proportion to the depth from the surface; but this hypothesis proceeded from imperfect and inaccurate observations; or from the preconceived notion of the existence of central fires. At great depths, it seems not impossible that the temperature of the earth is uniformly and invariably the same; that is, at depths beyond the more immediate influence of the sun's rays. But, at moderate depths, so far as observation and experiment go, the temperature of the earth is precisely the same as the average temperature of the climate where the observation is made. This fact, which is established by the uniform temperature of springs corresponding exactly with the average temperature of the climate, seems to be an irresistible argument against the opinion of the existence of central fires.

Heat.

This heat of the earth has been variously explained. Some have had recourse to an immense body of fire lodged in the centre of the earth, which they consider as a central sun, and the great principle of the generation, vegetation, nutrition, &c. of fossil and vegetable bodies. But Mr Boyle, who had been at the bottom of some mines himself, suspects that this degree of heat, at least in some of them, may arise from the peculiar nature of the minerals generated therein. To confirm this, he instances a mineral of a vitriolic kind, dug up in large quantities in many parts of England, which by the bare effusion of common water will grow so hot, that it will almost take fire.—These hypotheses are liable to the following objections: 1. If there is, within the earth, a body of actual fire, it seems difficult to show why that fire should not consume and moulder away the outer shell of earth, till either the earth was totally destroyed, or the fire extinguished. 2. If the internal heat of the earth is owing to the action of water upon mineral substances, that action through time must have ceased, and the heat have totally vanished; but we have no reason to think that the heat of the earth is any thing less just now than it was a thousand years ago. If heat is nothing else than a certain mode of action in the ethereal fluid, or the matter of light, by which it flows out from a body in all directions as radii drawn from the centre to the circumference of a circle; it will then follow, that if an opaque body absorbs any considerable quantity of light, it must necessarily grow hot. The reason of this is plain. The body can hold no more than a certain quantity of ethereal matter; if more is continually forcing itself in, that which has already entered must go out. But it cannot easily get out, because it is hindered by the particles of the body among which it is detained. It makes an effort, therefore, in all directions to separate these particles from each other; and hence the body expands, and the effort of the fluid to escape is felt when we put our hands on the body, which we then say is hot. Now, as the earth is perpetually absorbing the ethereal matter which comes from the sun in an immense stream, and which we call his light, it is plain that every pore of it must have been filled with this matter long ago. The quantity that is lodged in the earth, therefore, must be continually endeavouring to separate its particles from each other, and consequently must make it hot. The atmosphere, which is perpetually receiving that portion of the ethereal matter which issues from the earth, counteracts the force of the internal heat, and cools the external surface of the earth, and for a considerable way down; and hence, it is supposed, the earth for 20 or 30 feet down shows none of that heat, which is felt at greater depths. See HEAT.

HEAT, in Medicine. Great heats are not so much the immediate, as the remote, cause of a general sickness, by relaxing the fibres, and disposing the juices to putrefaction; especially among soldiers and persons exposed the whole day to the sun: for the greatest heats are seldom found to produce epidemic diseases, till the perspiration is stopped by wet clothes, fogs, dews, damps, &c. and then some bilious or putrid distemper is the certain consequence, as fluxes and ardent intermitting fevers. Nevertheless, it must be allowed, that heats have sometimes been so great, as to prove the more immediate cause of particular disorders, as when

sentinels

Heat
Heaven.

Heaven.

sentinels have been placed without cover or frequent reliefs in scorching heat; or when troops march or are exercised in the heat of the day; or when people im- prudently lie down and sleep in the sun. All these circumstances are apt to bring on distempers, varying according to the season of the year. In the begin- ning of summer, these errors produce inflammatory fe- vers; and in autumn, a remitting fever or dysentery. To prevent, therefore, the effects of immoderate heats, commanders have found it expedient so to order the marches, that the men come to their ground before the heat of the day; and to give strict orders, that none of them sleep out of their tents, which, in fixed en- campments, may be covered with boughs to shade them from the sun. It is likewise a rule of great importance to have the soldiers exercised before the cool of the morning is over; for by that means not only the sultry heats are avoided, but the blood being cooled, and the fibres braced, the body will be better prepared to bear the heat of the day. Lastly, in very hot weather, it has often been found proper to shorten the sentinels duty, when obliged to stand in the sun.

HEATH. See ERICA, BOTANY *Index*.

Berry-bearing HEATH. See EMPETRUM, BOTANY *Index*.

HEATH, James, an English historian, was born in 1629 at London; where his father, who was the king's cutler, lived. He was educated at Westminster school, and became a student of Christ-church, Oxford, in 1616. In 1648 he was ejected from thence by the parliament visitors for his adherence to the royal cause; lived upon his patrimony till it was almost spent; and then marrying, was obliged to write books and correct the press in order to maintain his family. He died of a consumption and dropsy at London in August 1664, and left several children to the parish. His principal publications were, 1. A brief Chronicle of the late Intestine War in the Three Kingdoms of England, Scotland, and Ireland, &c. 1661, 8vo; afterwards enlarged by the author, and completed from 1637 to 1663, in four parts, 1663, in a thick 8vo. To this was again added a continuation from 1663 to 1675 by John Philips, nephew by the mother to Mil- ton, 1676, folio. 2. Flagellum: or, The Life and Death, Birth and Burial, of Oliver Cromwell, the late Usurper, 1663. The third edition came out with additions in 1665, 8vo. 3. A New Book of Loyal English Martyrs and Confessors, who have endured the Pains and Terrors of Death, Arraignment, &c. for the Maintenance of the just and legal Government of these Kingdoms both in Church and State, 1663, 12mo. The reason why such writers as our author continue to be read, and will probably always be read, is not only because *Historia quoquo modo scripta delectat*; but also because in the meanest historian there will always be found some facts, of which there will be no cause to doubt the truth, and which yet will not be found in the best. Thus Heath, who perhaps had nothing but pamphlets and newspapers to compile from, frequently relates facts that throw light upon the history of those times, which Clarendon, though he drew every thing from the most authentic records, has omitted.

HEATHENS, in matters of religion. See PAGANS.

HEAVEN, literally signifies the expanse of the fir-

ament surrounding our earth, and extending every way to an immense distance.

HEAVEN, among Christian divines and philosophers, is considered as a place in some remote part of infinite space, in which the omnipresent Deity is said to afford a nearer and more immediate view of himself, and a more sensible manifestation of his glory, than in the other parts of the universe. This is often called the *empyrean*, from that splendour with which it is supposed to be invested; and of this place the inspired writers give us the most noble and magnificent descriptions.

The Pagans considered heaven as the residence only of the celestial gods, into which no mortals were admitted after death, unless they were deified. As for the souls of good men, they were consigned to the *elysian fields*. See *ELYSIAN Fields*.

HEAVEN, among astronomers, called also the *ethereal* and *starry* heaven, is that immense region wherein the stars, planets, and comets, are disposed. See *ASTRONOMY Index*.

This is what Moses calls the *firmament*, speaking of it as the work of the second day's creation; at least it is thus the word *קִיפָה* is usually rendered by his interpreters; though somewhat abusively, to countenance their own notion of the heavens being firm or solid. The word, it is certain, properly signifies no more than expanse or extension; a term very well adapted by the prophet to the impression which the heavens make on our senses; whence, in other parts of scrip- ture, the heaven is compared to a curtain, or a tent stretched out to dwell in. The LXX first added to this idea of expansion that of firm or solid; render- ing it by *στέγανον*, according to the philosophy of those times; in which they have been followed by the modern translators.

The latter philosophers, as Des Cartes, Kircher, &c. have easily demonstrated this heaven not to be solid, but fluid; but they still suppose it full, or perfectly dense, without any vacuity, and canted out into many vor- tices.—But others have overturned not only the soli- dity, but the supposed plenitude, of the heavens. Sir Isaac Newton has abundantly shown the heavens void of almost all resistance, and, consequently, of almost all matter: this he proves from the phenomena of the celestial bodies; from the planets persisting in their motions without any sensible diminution of their ve- locity; and the comets freely passing in all directions towards all parts of the heavens.

Heaven, taken in a general sense, for the whole ex- pance between our earth and the remotest regions of the fixed stars, may be divided into two very unequal parts, according to the matter found therein; viz. the atmosphere, or aerial heaven, possessed by air; and the ethereal heaven, possessed by a thin, unresisting me- dium, called *ether*.

HEAVEN is more particularly used, in *Astronomy*, for an orb, or circular region, of the ethereal heaven.

The ancient astronomers assumed as many different heavens as they observed different motions therein. These they supposed all to be solid, as thinking they could not otherwise sustain the bodies fixed in them; and spherical, that being the most proper form for motion. Thus we had seven heavens for the seven planets, viz. the heavens of the Moon, Mercury, Venus, the Sun,

Heaven
||
Hebe.

Mars, Jupiter, and Saturn. The eighth was for the fixed stars, which they particularly called the *firmament*. Ptolemy adds a ninth heaven, which he called the *primum mobile*. After him two crystalline heavens were added by King Alphonsus, &c. to account for some irregularities in the motions of the other heavens: and lastly, an empyrean heaven was drawn over the whole, for the residence of the Deity; which made the number twelve. But others admitted many more heavens, according as their different views and hypotheses required. Eudoxus supposed 23, Calippus 30, Regiomontanus 33, Aristotle 47, and Fracastor no less than 70. It must be added, however, that the astronomers did not much concern themselves whether the heavens they thus allow of were real or not; provided they served a purpose in accounting for any of the celestial motions, and agreed with the phenomena.

HEBDOMADARY, HEBDOMADARIUS, or HEBDOMADIUS, a member of a chapter or convent, whose week it is to officiate in the choir, to rehearse the anthems and prayers, and to perform the usual functions which the superiors perform at solemn feasts, and other extraordinary occasions. The word is formed of the Greek *ἑβδομας*, which signifies the number seven; of *ἑβρα*, seven.

The hebdomadary generally collates to the benefices which become vacant during his week; though it is usually looked upon as an abuse.

In cathedrals, the hebdomadary was a canon or prebendary, who had the peculiar care of the choir, and the inspection of the offices for his week.

In monasteries, the hebdomadary is he who waits at table for a week, or other stated period; directs and assists the cook, &c.

HEBDOME, a solemnity of the ancient Greeks, in honour of Apollo, in which the Athenians sung hymns to his praise, and carried in their hands branches of laurel. The word signifies the *seventh day*, this solemnity being observed on the seventh day of every lunar month.

HEBE, in ancient mythology, a goddess, the idea of whom, among the Romans, seems to have been much the same with that of eternal youth, or an immortality of bliss; agreeably to which, she is represented on a gem, in the great duke's collection at Florence, with a young airy look, and drinking out of a little bowl; or, according to Milton's expression, "Quaffing immortality and joy." She is fabled to have been a daughter of Jupiter and Juno. According to some she was the daughter of Juno only, who conceived her after eating lettuces. As she was fair and always in the bloom of youth, she was called the goddess of youth, and made by her mother cup-bearer to all the gods. She was dismissed from her office by Jupiter, because she fell down in an indecent posture as she was pouring nectar to the gods at a grand festival; and Ganymedes, the favourite of Jupiter, succeeded her as cup-bearer. She was employed by her mother to prepare her chariot, and to harness her peacocks whenever requisite. When Hercules was raised to the rank of a god, he was reconciled to Juno by marrying her daughter Hebe, by whom he had two sons, Alexiades and Anicetus. As Hebe had the power of restoring gods and men to the vigour of youth, she, at the instance of her husband, performed that kind office to Iolaus his friend. Hebe

was worshipped at Sicyon, under the name of *Dia*, and at Rome under that of *Juventas*.

HEBENSTRETIA, a genus of plants belonging to the didynamia class; and in the natural method ranking under the 48th order, *Aggregatæ*. See **BOTANY Index**.

HEBER, the son of Salab, and father of Peleg, from whom the Hebrews derived their name, according to Josephus, Eusebius, Jerome, Bede, and most of the interpreters of the sacred writings; but Huet bishop of Avranches, in his *Evangelical Demonstration*, has attempted to prove, that the Hebrews took their name from the word *heber*, which signifies *beyond*, because they came from beyond the Euphrates. Heber is supposed to have been born 2281 years B. C. and to have lived 464 years.

HEBRAISM, an idiom, or manner of speaking, peculiar to the Hebrew language. See the next article.

HEBREW, something relating to the Hebrew. See **HEBREWS**. Thus we say, *HEBREW Bible*. See **BIBLE**.

HEBREW Character. There are two kinds of Hebrew characters: the ancient, called also the *square*; and the modern, or rabbinical character.

1. The square Hebrew takes its denomination from the figure of its characters, which stand more square, and have their angles more exact and precise than the other. This character is used in the text of Holy Scripture, and their other principal and most important writings. When both this and the rabbinical character are used in the same work, the former is for the text, or the fundamental part; and the latter for the accessory part, as the gloss, notes, commentaries, &c.

The best and most beautiful characters of this kind, are those copied from the characters in the Spanish manuscripts; next, those from the Italian manuscripts; then those from the French; and, lastly, those of the Germans, whose characters are much the same, with respect to the other genuine square Hebrew characters, that the Gothic or Dutch characters are with respect to the Roman.

Several authors contend, that the square character is not the real ancient Hebrew character, written from the beginning of the language to the time of the Babylonish captivity; but that it is the Assyrian or Chaldee character, which the Jews assumed, and accustomed themselves to, during the captivity, and retained afterwards. They say, that the Jews, during their captivity, had quite disused their ancient character; so that Ezra found it necessary to have the sacred books transcribed into the Chaldee square character. These authors add, that what we call the Samaritan character, is the genuine ancient Hebrew. Of this opinion are Scaliger, Bochart, Casaubon, Vossius, Grotius, Walton, Capellus, &c. and among the ancients Jerome and Eusebius. On this side it is urged, that the present characters are called Assyrian by the ancient Jewish writers of the Talmud, and therefore must have been brought from Assyria: but to this argument it is replied, that there were two sorts of characters anciently in use, viz. the sacred or present square character, and the profane or civil, which we call Samaritan; and that the sacred is called Assyrian, because it first began in Assyria to come into common use. It is farther alleged,

Hebe
||
Hebrew.

Hebrew. leged, that the Chaldee letters, which the Jews now use, were unknown to the ancient Jews before the captivity, from Dan. i. 4. Moreover, it is inferred from 2 Kings xvii. 28. whence we learn that a Jewish priest was sent to teach the Samaritans the worship of Jehovah; on which occasion he must have taught them the law; and yet no mention occurs of his teaching them the language or character that the law was then written in, the character which the Samaritans used. But the chief argument is taken from some ancient Jewish shekels, with a legend on one side "The shekel of Israel," and on the other "Jerusalem the holy," both in Samaritan characters. These shekels, it is said, must have been coined before the division of the two kingdoms of Judah and Israel, or at least before the Assyrian captivity, because the Samaritans never afterwards reckoned Jerusalem holy. On the other side, or for the primitive antiquity of the square character, are the two Buxtorfs, Leusden, Calovius, Hottinger, Spanheim, Lightfoot, &c. They urge, from Matthew v. 18. that *iod* is really the least of the consonants in the present Hebrew, whereas it is one of the largest characters in the Samaritan alphabet: but Walton replies, that if our Saviour here speaks of the least letter of the alphabet, we can only infer, that the Chaldee character was used in our Saviour's time, which is not denied by those who maintain the Samaritan to be the original. They also allege, that the Jews were too obstinate and superstitious to allow their sacred character to be altered; but if this was done under the direction and authority of Ezra, the argument will be much invalidated. Farther, they say, that Ezra could not alter the ancient character, because it was impossible to make the alterations in all their copies. This argument, however, is contradicted by fact; since the old English black letter is actually changed for the Roman. They say, likewise, that Ezra was not disposed to profane the sacred writings with a heathen character: but this supposes that Ezra was so superstitious as to imagine, that there was some peculiar sanctity in the shape of the letters. Moreover, the advocates for this opinion appeal to ancient coins found in Judea, with a legend in the Chaldee or Assyrian character. But the genuineness of these coins is much suspected.

The learned Jesuit Soucier maintains, with great address, that the ancient Hebrew character is that found on the medals of Simon, and others, commonly called *Samaritan medals*; but which, he asserts, were really Hebrew medals, struck by the Jews, and not the Samaritans.

Buxtorf endeavours to reconcile these two opinions, by producing a variety of passages from the rabbies to prove, that both these characters were anciently used; the present square character being that in which the tables of the law, and the copy deposited in the ark, were written; and the other character being used in the copies of the law which were written for private and common use, and in civil affairs in general; and that after the captivity, Ezra enjoined the former to be used by the Jews on all occasions, leaving the latter to the Samaritans and apostates. But it can hardly be allowed by any who consider the difference between the Chaldee and Samaritan characters, with respect to convenience and beauty, that they were ever used at the same time. After all, it is of no great moment

Hebrew. which of these, or whether either of them, were the original characters; since it appears, that no change of the words has arisen from the manner of writing them, because the Samaritan and Jewish Pentateuch almost always agree after so many ages. It is most probable that the form of these characters has varied in different periods; this appears from the testimony of Montfaucon, in his *Hexapla Origenis*, vol. i. p. 22. &c. and is implied in Dr Kennicot's making the characters in which manuscripts are written one test of their age.

2. The modern, or rabbinical, is a good neat character, formed of the square Hebrew, by rounding it, and retrenching most of the angles or corners of the letters, to make it the more easy and flowing. The letters used by the Germans are very different from the rabbinical character used everywhere else, though all formed alike from the square character, by the German in a more slovenly manner than the rest.—The rabbins frequently make use either of their own, or the square Hebrew character, to write the modern languages in. There are even books in the vulgar tongues printed in Hebrew characters; instances whereof are seen in the French king's library.

HEBREW Language, that spoken by the Hebrews, and wherein the Old Testament is written.

This appears to be the most ancient of all the languages in the world, at least we know of none older; and some learned men are of opinion, that this is the language in which God spoke to Adam in Paradise. Dr Sharpe adopts the opinion that the Hebrew was the original language; not indeed that the Hebrew is the unvaried language of our first parents, but that it was the general language of men at the dispersion; and however it might have been improved and altered from the first speech of our first parents, it was the original of all the languages, or almost all the languages, or rather dialects, that have since arisen in the world.

The books of the Old Testament are the only pieces to be found, in all antiquity, written in pure Hebrew; and the language of many of these is extremely sublime: it appears perfectly regular, and particularly so in its conjugations. Indeed, properly speaking, it has but one conjugation; but this is varied in each seven or eight different ways, which has the effect of so many different conjugations, and affords a great variety of expressions to represent by a single word the different modifications of a verb, and many ideas which in the modern and in many of the ancient and learned languages cannot be expressed without a periphrasis.

The primitive words, which are called *roots*, have seldom more than three letters or two syllables.

In this language there are 22 letters, only five of which are usually reckoned vowels, which are the same with ours, viz. *a, e, i, o, u*; but then each vowel is divided into two, a long and a short, the sound of the former being somewhat grave and long, and that of the latter short and acute: it must however be remarked, that the two last vowels have sounds that differ in other respects besides quantity and a greater or less elevation. To these 10 or 12 vowels may be added others, called *semi-vowels*, which serve to connect the consonants, and to make the easier transitions from one

Hebrew. to another. The number of accents in this language is indeed prodigious: of these there are near 40, the use of some of which, notwithstanding all the inquiries of the learned, are not yet perfectly known. We know, in general, that they serve to distinguish the sentences like the points called *commas*, *semicolons*, &c. in our language; to determine the quantity of the syllables; and to mark the tone with which they are to be spoken or sung. It is no wonder, then, that there are more accents in the Hebrew than in other languages, since they perform the office of three different things, which in other languages are called by different names.

As we have no Hebrew but what is contained in the Scripture, that language to us wants a great many words; not only because in those primitive times the languages were not so copious as at present; but also on this account, that the inspired writers had no occasion to mention many of the terms that might be in the language.

The Chaldee, Syriac, Ethiopic, &c. languages, are by some held to be only dialects of the Hebrew; as the French, Italian, Spanish, &c. are dialects of the Latin. It has been supposed by many very learned men, that the Hebrew characters or letters were often used hieroglyphically, and that each had its several distinct sense understood as a hieroglyphic. Neuman, who seems to have taken infinite pains to find out this secret meaning of these letters, gives the following explication: א *aleph*, he says, is a character denoting motion, readiness, and activity; ב *beth*, signifies, 1. Matter, body, substance, thing; 2. Place, space, or capacity; and, 3. In, within, or contained: ג *gimel*, stands for flexion, bending, or obliquity of any kind: ד *daleth*, signifies any protrusion made from without, or any promotion of any kind: ה *he*, stands for presence, or demonstrative essence of any thing: ו *vau*, stands for copulation or growing together of things: ז *zain*, expresses vehement protrusion and violent compression, such as is occasioned by at once violently discharging and constringing a thing together; it also signifies sometimes the straitening of any figure into a narrow point at the end: ח *cheth*, expresses association, society, or any kind of composition or combination of things together: ט *teth*, stands for the withdrawing, drawing back, or recess of any thing: י *jod*, signifies extension and length, whether in matter or in time: כ *caph*, expresses a turning, curvedness, or concavity: ל *lamech*, stands for an addition, access, impulse, or adversation, and sometimes for pressure: מ *mem*, expresses amplitude, or the amplifying any thing in whatever sense; in regard to contiguous qualities, it signifies the adding length, breadth, and circumference; and in disjunct qualities it signifies multitude: נ *nun*, signifies the propagation of one thing from another, or of the same thing from one person to another: ס *samech*, expresses cincture and coarctation: פ *ain*, stands for observation, objection, or obviation: צ *pe*, stands for a crookedness or an angle of any figure: ק *tsade*, expresses contiguity and close succession: ק *koph*, expresses a circuit or ambit: ר *resh*, expresses the egress of any thing, as also the exterior part of a thing, and the extremity or end of any thing: ש *shin*, signifies the number three, or the third degree, or the utmost perfection of any thing: ט *tau*,

expresses a sequel, continuation, or succession of any thing. Hebrew Hebrides

According to this explication, as the several particular letters of the Hebrew alphabet separately signify the ideas of motion, matter, space, and several modifications of matter, space, and motion, it follows that a language, the words of which are composed of such expressive characters, must necessarily be of all languages the most perfect and expressive, as the words formed of such letters, according to their determinate separate significations, must convey the idea of all the matters contained in the sense of the several characters, and be at once a name and a definition, or succinct description of the subject, and all things material as well as spiritual, all objects in the natural and moral world, must be known as soon as their names are known, and their separate letters considered.

The words *urim* and *thummim* are thus easily explained, and found perhaps the most apposite and expressive words that were ever formed.

Rabbinical or modern HEBREW, is the language used by the rabbins in the writings they have composed. The basis or body hereof is the Hebrew and Chaldee, with divers alterations in the words of these two languages, the meanings whereof they have considerably enlarged and extended. Abundance of things they have borrowed from the Arabic: the rest is chiefly composed of words and expressions, chiefly from the Greek; some from the Latin; and others from the other modern tongues; particularly that spoken in the place where each rabbin lived or wrote.

The rabbinical Hebrew must be allowed to be a very copious language. M. Simon, in his *Hist. Crit. du Vieux Testam.* liv. iii. chap. 27. observes, that there is scarce any art or science but the rabbins have treated thereof in it. They have translated most of the ancient philosophers, mathematicians, astronomers, and physicians; and have written themselves on most subjects: they do not want even orators and poets. Add, that this language, notwithstanding it is so crowded with foreign words, has its beauties visible enough in the works of those who have written well in it.

HEBREWS, the descendants of Heber, commonly called *Jews*. See **HEBREW** and **JEWS**.

HEBREWS, or *Epistle to the Hebrews*, a canonical book of the New Testament.

Though St Paul did not prefix his name to this epistle, the concurrent testimony of the best authors ancient and modern afford such evidence of his being the author of it, that the objections to the contrary are of little or no weight.

The Hebrews, to whom this epistle was written, were the believing Jews of Palestine; and its design was to convince them, and by their means all the Jewish converts wheresoever dispersed, of the insufficiency and abolishment of the ceremonial and ritual law.

HEBRIDES, the general name of some islands lying to the north-west of Scotland, of which kingdom they constitute a part. They are situated between the 55th and 59th degrees of latitude, are supposed to be about 300 in number, and to contain 48,000 inhabitants. The names of the largest are **LEWIS**, **SKY**, **MULL**, **ILAY**, and **ARRAN**. Of these islands Mr Pennant hath given the following history.

"All the accounts left us by the Greek and Roman writers

writers are enveloped with obscurity; at all times brief eyes in their descriptions of places they had easiest access to, and might have described with the most satisfactory precision; but in remote places, their relations furnish little more than hints, the food for conjecture to the visionary antiquary.

“That Pytheas, a traveller mentioned by Strabo, had visited Great Britain, I would wish to make only *apocryphal*. He asserts that he visited the remotest parts; and that he had also seen Thule, the land of romance amongst the ancients; which all might pretend to have seen; but every voyager, to swell his fame, made the island he saw, last the Ultima Thule of his travels. If Pytheas had reached those parts, he might have observed, floating in the seas, multitudes of gelatinous animals, the *medusa* of Linnæus, and out of these have formed his fable. He made his THULE a composition of neither earth, sea, nor air; but like a composition of them all; thus, catching his simile from what floated before him, compares it to the *lunga* of the sea, the Aristotelian idea of these bodies; and from him adopted by naturalists, successors to that great philosopher. Strabo very justly explodes these absurd tales; yet allows him merit in describing the climate of the places he had seen. As a farther proof of his having visited the Hebrides, he mentions their unfriendly sky, that prohibits the growth of the finer fruits; and that the natives are obliged to carry their corn under shelter, to beat the grain out; lest it should be spoiled by the defect of sun and violence of the rains. This is the probable part of his narrative; but when the time that the great geographer wrote is considered, at a period that these islands had been neglected for a very long space by the Romans, and when the difficulties of getting among a fierce and unfriendly nation must be almost insurmountable, doubts innumerable respecting the veracity of this relation must arise. All that can be admitted in favour of him is, that he was a great traveller; and that he might have either visited Britain from some of the nations commencing with our island, or received from them accounts, which he afterwards dressed out, mixed with the ornaments of fable. A traffic must have been carried on with the very northern inhabitants of our islands in the time of Pytheas, for one of the articles of commerce mentioned by Strabo, the ivory bills, were made either of the teeth of the walrus, or of a species of whale native of the northern seas.

“The geographer Mela, who flourished in the reign of Claudius, is the next who takes notice of our island. He mentions the *Orades* as consisting of 30; the *Æmodæ* of seven. The Romans had then made a conquest of the former, and might have seen the latter; but, from the words of the historian, it is probable that the Shetland islands were those intended; for he informs us, that the *Æmodæ* were carried out over against Germany;” the site of the Hebrides will not admit this description, which agrees very well with the others; for the ancients extended their Germany, and its imaginary islands, to the extreme north.

“Pliny the Elder is the next that mentions these remote places. He lived later than the preceding writers, and of course his information is fuller; by means of interesting discoveries he has added ten more to the number of the *Orades*; is the first writer that

mentions the *Hœbudæ*, the islands in question; and joins in the same line *Æmodæ*, or, as it is in the best editions more properly written, the *Acmodæ*, or extreme point of the Roman expeditions to the north; as the Shetland isles in the highest probability were. Pliny and Mela agree in the number of the *Æmodæ*, or *Acmodæ*; the former makes that of the *Hœbudæ* 30; an account extremely near the truth, deducting the little isles, or rather rocks, that surround most of the greater, and many of them so indistinct as scarcely to be remarked, except on an actual survey.

“Solinus succeeds Pliny. If he, as is supposed, was contemporary with Agricola, he has made very ill use of the light he might have received from the expeditions of that great general; his officers might have furnished the historian with better materials than those he has communicated. He has reduced the number of the *Hœbudæ* to five. He tells us, that “the inhabitants were unacquainted with corn; that they lived only on fish and milk; that they had one king; as the islands were only separated from each other by narrow straits; that their prince was bound by certain rules of government to do justice; and was prevented by poverty from deviating from the true course; being supported by the public; and allowed nothing that he could call his own; not even a wife; but then he was allowed free choice, by turns one out of every district, of any female that caught his affection; which deprived him of all ambition about a successor.

“By the number of these islands, and by the minute attention given by the historian to the circumstance of their being separated from each other by very narrow straits, I should imagine, that which is now called the *Long Island*, and includes Lewis, North Uist, Benbecula, South Uist, and Barra, to have been the five *Hœbudæ* of Solinus; for the other great islands, such as Skye, Saig, are too remote from each other to form the preceding very characteristic description of that chain of islands. These might naturally fall under the rule of one petty prince; almost the only probable part of Solinus’s narrative.

“After a long interval appears Ptolemy, the Egyptian geographer. He also enumerates five *Ebudæ*; and has given each a name; the western *Ebuda*, the Eastern, *Rivina*, *Mulboa*, *Epidium*. Camden conjectures that to be the modern Skye, Lewis, Rathry, or Ratline, Mull, and Ilay; and I will not controvert his opinion.

“The Roman historians give very little light into the geography of these parts. Tacitus, from whom most might have been expected, is quite silent about the names of places; notwithstanding he informs us, that a fleet by the command of Agricola performed the circumnavigation of Britain. All that he takes notice of is the discovery and the conquest of the Orkneys; it should seem, that with the biographers of an ambitious nation, nothing seemed worthy of notice but what they could dignify with the glory of victory.

“It is very difficult to assign a reason for the change of name from *Ebudæ* to *Hebrides*; the last is modern; and seems, as the annotator on Dr Macpherson supposes, to have arisen from the error of a transcriber, who changed the *æ* into *v*.

“From

Hebrides.

“ From all that has been collected from the ancients, it appears, that they were acquainted with little more of the Hebrides than the bare names: it is probable, that the Romans, either from contempt of such barren spots, from the dangers of the seas, the violence of the tides, and horrors of the narrow sounds, in the inexperienced ages of navigation, never attempted their conquest, or saw more of them than what they had in sight during the few circumnavigations of Great Britain, which were expeditions more of ostentation than of utility.

“ The inhabitants had probably for some ages their own governors, one little king to each island, or to each group, as necessity required. It is reasonable to suppose, that their government was as much divided as that of Great Britain, which, it is well known, was under the direction of numbers of petty princes before it was reduced under the power of the Romans.

“ No account is given in history of the time these islands were annexed to the government of Scotland. If we may credit our Saxon historians, they appear to have been early under the dominion of the Picts; for Bede and Adamnanus inform us, that soon after the arrival of St Columba in their country, Brude, a Pictish monarch, made the saint a present of the celebrated island of Iona. But neither the holy men of this island, nor the natives of the rest of the Hebrides, enjoyed a permanent repose after this event. The first invasion of the Danes does not seem to be easily ascertained. It appears that they ravaged Ireland, and the isle of Rathry, as early as the year 735. In the following century, their expeditions became more frequent; Harold Harfager, or the *light-haired*, pursued, in 875, several petty princes, whom he had expelled out of Norway; who had taken refuge in the Hebrides, and molested his dominions by perpetual descents from those islands. He seems to have made a rapid conquest: he gained as many victories as he fought battles; he put to death the chief of the pirates, and made an indiscriminate slaughter of their followers. Soon after his return, the islanders repossessed their ancient seats; and, in order to repress their insults, he sent Ketil the *flat-nosed* with a fleet and some forces for that purpose. He soon reduced them to terms, but made his victories subservient to his own ambition; he made alliances with the reguli he had subdued; he formed intermarriages, and confirmed to them their old dominions. This effected, he sent back the fleet to Harold; openly declared himself independent; made himself prince of the Hebrides; and caused them to acknowledge him as such, by the payment of tribute and the badges of vassalage. Ketil remained, during life, master of the islands; and his subjects appear to have been a warlike set of freebooters, ready to join with any adventurers. Thus when Eric, son of Harold Harfager, after being driven out of his own country, made an invasion of England, he put with his fleet into the Hebrides, received a large reinforcement of people fired with the hopes of prey, and then proceeded on his plan of rapine. After the death of Ketil, a kingdom was in after times composed out of them, which, from the residence of the little monarch in the isle of Man, was styled that of *Man*.

3

Hebrides.

The islands became tributary to that of Norway for a considerable time, and princes were sent from thence to govern; but at length they again shook off the yoke. Whether the little potentates ruled independent, or whether they put themselves under the protection of the Scottish monarchs, does not clearly appear: but it is reasonable to suppose the last, as Donald-bane is accused of making the Hebrides the price of the assistance given him by the Norwegians against his own subjects. Notwithstanding they might occasionally seek the protection of Scotland, yet they never were without princes of their own: policy alone directed them to the former. From the chronicles of the kings of Man we learn, that they had a succession of princes.

“ In 1089 is an evident proof of the independency of the islanders on Norway; for, on the death of Lagnan, one of their monarchs, they sent a deputation to O'Brian king of Ireland, to request a regent of royal blood to govern them during the minority of their young prince. They probably might in turn compliment in some other respects their Scottish neighbours: the islanders must have given them some pretence to sovereignty; for,

“ In 1093, Donald-bane, king of Scotland, calls in the assistance of Magnus the Barefooted, king of Norway, and bribes him with the promise of all the islands. Magnus accepts the terms; but at the same time boasts, that he does not come to invade the territories of others, but only to resume the ancient rights of Norway. His conquests are rapid and complete; for, besides the islands, by an ingenious fraud he adds Cantyre to his dominions.

“ The Hebrides continued governed by a prince dependent on Norway, a species of viceroy appointed by that court; and who paid, on assuming the dignity, ten marks of gold, and never made any other pecuniary acknowledgment during life: but if another viceroy was appointed, the same sum was exacted from him. These viceroys were sometimes Norwegians, sometimes natives of the isles. In 1097 we find, that Magnus deposes a nobleman of the name of *Ingemund*: in after times we learn, that natives were appointed to that high office. Thus were the Hebrides governed, from the conquest by Magnus, till the year 1263, when Acho, or Haquin, king of Norway, by an unfortunate invasion of Scotland, terminating in his defeat at Largs, so weakened the powers of his kingdom, that his successor Magnus IV. was content to make a cession of the islands to Alexander III.; but not without stipulating for the payment of a large sum, and a tribute of 100 merks for ever, which bore the name of the *annual of Norway*. Ample provision was also made by Magnus in the same treaty, for the security of the rights and properties of his Norwegian subjects who chose to continue in the isles, where many of their posterity remain to this day.

“ Notwithstanding this revolution, Scotland seems to have received no real acquisition of strength. The islands still remained governed by powerful chieftains, the descendants of Somersd, thane of Heregaidel, or Argyll, who, marrying the daughter of Olave, king of Man, left a divided dominion to his sons Dugal and Reginald; from the first were descended the Macdougals

Hebrides. Macdougals of Lorn; from the last, the powerful clan of the Macdonalds. The lordship of Argyle, with Mull, and the islands north of it, fell to the share of the first; Ilay, Cantyre, and the southern isles, were the portion of the last: a division that formed the distinction of the Sudereys and Nordereys, (as further noticed in the article IONA).

"These chieftains were the scourges of the kingdom: they are known in history but as the devastations of a tempest; for their paths were marked with the most barbarous desolation. Encouraged by their distance from the seat of royalty, and the turbulence of the times, which gave their monarchs full employ, they exercised a regal power, and often assumed the title; but are more generally known in history by the style of the *lords of the isles*, or the earls of Ross; and sometimes by that of the *Great Macdonald*.

"Historians are silent about their proceedings, from the retreat of the Danes, in 1263, till that of 1335, when John, lord of the isles, withdrew his allegiance. In the beginning of the next century his successors were so independent, that Henry IV. entered into a formal alliance with the brothers Donald and John. This encouraged them to commit fresh hostilities against their natural prince. Donald, under pretence of a claim to the earldom of Ross, invaded and made a conquest of that county: but penetrating as far as the shire of Aberdeen, after a fierce but undecisive battle with the royal party, thought proper to retire, and in a little time to swear allegiance to his monarch James I. But he was permitted to retain the county of Ross, and assume the title of earl. His successor, Alexander, at the head of 10,000 men, attacked and burnt Inverness; at length terrified with the preparations made against him, he fell at the royal feet, and obtained pardon as to life, but was committed to strict confinement.

"His kinsman and deputy, Donald Balloch, resenting the imprisonment of his chieftain, excited another rebellion, and destroyed the country with fire and sword; but on his flight was taken and put to death by an Irish chieftain, with whom he sought protection."

"These barbarous inroads were very frequent with a set of banditti, who had no other motive in war but the infamous inducement of plunder.

"In the reign of James II. in the year 1461, Donald, another petty tyrant, an earl of Ross, and lord of the isles, renewed the pretence of independency; surprised the castle of Inverness; forced his way as far as Athol; and obliged the earl and countess, with the principal inhabitants, to seek refuge in the church of St Bridget, in hopes of finding security from his cruelty by the sanctity of the place: but the barbarian and his followers set fire to the church, put the ecclesiastics to the sword, and, with a great booty, carried the earl and countess prisoners to his castle of Clai, in the island of Ilay. In a second expedition, immediately following the first, he suffered the penalty of his impiety: a tempest overtook him, and overwhelmed most of his associates; and he, escaping to Inverness, perished by the hands of an Irish harper; his surviving followers returned to Ilay, conveyed the earl and countess of Athol to the sanctuary they had

VOL. X. Part I.

Hebrides. violated, and expiated their crime by restoring the plunder, and making large donations to the shrine of the offended saint.

"John, successor to the late earl of Ross, entered into alliance with Edward IV. and sent ambassadors to the court of England, where Edward empowered the bishop of Durham and earl of Winchester to conclude a treaty with him, another Donald Balloch, and his son and heir John. They agreed to serve the king with all their power, and to become his subjects: the earl was to have 100 marks sterling for life in time of peace, and 200l. in time of war; and these island allies, in case of the conquest of Scotland, were to have confirmed to them all the possessions benorth of the Scottish sea; and in case of a truce with the Scottish monarch, they were to be included in it. But about the year 1476, Edward, from a change of politics, courted the alliance of James III. and dropt his new allies. James, determined to subdue this rebellious race, sent against them a powerful army under the earl of Athol; and took leave of him with this good wish, *Furth, Fortune, and fill the fetters*; as much as to say, "Go forth, be fortunate, and bring home many captives;" which the family of Athol has used ever since for its motto. Ross was terrified into submission; obtained his pardon; but was deprived of his earldom, which by act of parliament was then declared unalienably annexed to the crown; at the same time the king restored to him Knapdale and Cantyre, which the earl had resigned; and invested him anew with the lordship of the isles, to hold them of the king by service and relief.

"Thus the great power of the isles was broken: yet for a considerable time after, the petty chieftains were continually breaking out into small rebellions, or harassed each other in private wars; and tyranny seems but to have been multiplied. James V. found it necessary to make the voyage of the isles in person in 1536, seized and brought away with him several of the most considerable leaders, and obliged them to find security for their own good behaviour and that of their vassals. The names of these chieftains were (according to Lindsay), *Mydyart, Mac-connel, Mac-loyd* of the Lewis; *Mac-niel, Mac-lane, Mac-intosh, John Mudyart, Mac-kay, Mac-kensie*, and many others; but by the names of some of the above, there seem to have been continental as well as insular malecontents. He examined the titles of their holdings, and finding several to have been usurped, reunited their lands to the crown. In the same voyage he had the glory of causing a survey to be taken of the coasts of Scotland, and of the islands, by his pilot Alexander Lindsay; which were published in 1583, at Paris, by Nicholas de Nicholay, geographer to the French monarch.

"The troubles that succeeded the death of James occasioned a neglect of these insulated parts of the Scottish dominions, and left them in a state of anarchy. In 1614, the Mac-donalds made a formidable insurrection, oppugning the royal grant of Cantyre to the earl of Argyle and his relations. The petty chieftains continued in a sort of rebellion; and the sword of the greater, as usual in weak governments, was employed against them; the encouragement and protection given by them to pirates employed the power of the Camp-

R r

bells

Hebrides. bells during the reign of James VI. and the beginning of that of Charles I. (A).

"But the turbulent spirit of the old times continued even to the present age. The heads of clans were by the divisions, and a false policy that predominated in Scotland during the reign of William III. flattered with an ideal importance: instead of being treated as bad subjects, they were courted as desirable allies: instead of feeling the hand of power, money was allowed to bribe them into the loyalty of the times. They would have accepted the subsidies, notwithstanding they detested the prince that offered them. They were taught to believe themselves of such consequence, that in these days turned to their destruction. Two recent rebellions gave legislature a late experience of the folly of permitting the feudal system to exist in any part of its dominions. The act of 1748, for abolishing heritable jurisdictions, at once deprived the chieftains of all power of injuring the public by their commotions. Many of the *Reguli* second this effort of legislature, and neglect no opportunity of rendering themselves hateful to their unhappy vassals, the former instruments of their ambition."

Smollet's
Mod. Hist.
i. 43c, &c.

"The situation of these islands in the great Atlantic ocean renders the air cold and moist in the greater part of them. In the most northerly isles the sun, at the summer solstice, is not above an hour under the horizon at midnight, and not longer above it at mid-day in the depth of winter. The soil of the Hebrides varies also in different isles, and in different parts of the same island: some are mountainous and barren, producing little else than heath, wild myrtle, fern, and a little grass; while others being cultivated and manured with sea-weed, yield plentiful crops of oats and barley.

"Lead mines have been discovered in some of these islands, but not worked to much advantage; others have been found to contain quarries of marble, lime-stone, and freestone; nor are they destitute of iron, talc, crystals, and many curious pebbles, some of which emulate the Brazilian topaz.

"With respect to vegetables, over and above the plentiful harvests of corn that the natives earn from agriculture, and the pot-herbs and roots that are planted in gardens for the sustenance of the people, these islands produce spontaneously a variety of plants and simples, used by the islanders in the cure of their diseases; but there is hardly a shrub or tree to be seen, except in a very few spots, where some gentlemen have endeavoured to rear them with much more trouble than success.

"The animals, both of the land and sea, domestic and wild, quadrupeds, fowls, and fishes, found in and about these islands, are of the same species, size, and configuration with those of the ORKNEYS.

"The people inhabiting these islands are of the same race with those who live in the Highlands of Scotland; speak the same language, wear the same habit, and observe the same customs. [See the article HIGHLANDS.]

Hebrides. "The commodities which may be deemed the staples of this country are black cattle, sheep, and fish, which they sell to their fellow-subjects of Scotland. Part of the wool they work up into knit-stockings, coarse cloth, and that variegated stuff called *tartan*. They likewise salt mutton in the hide, and export it in boats or barklings to different parts of the main land. Cod, ling, mackerel, whiting, haddock, and soles, are here caught in abundance, together with a small red cod, remarkably voracious, of a very delicate flavour: there are likewise two kinds of white fish, which seem to be peculiar to this coast, known by the names of *lithe* and *cea*, esteemed good eating. But the greatest treasure the ocean pours forth is the prodigious quantity of herrings, which, at one season of the year, swarm in all the creeks and bays along the western shore of Scotland. These are counted the largest, fattest, and finest herrings, caught in any part of the northern seas. This fishery employs a great number of hands, and brings a considerable advantage to the kingdom. The fish are caught, cured, barreled up, and exported: but whether from want of skill, or a proper salt for pickling, the Scotch-cured herrings of this coast, though superior to all others in their natural state, are counted inferior to those which are dressed and pickled by the Dutch fishermen.

"How mean and contracted soever the commerce and produce of these islands may be at present, they are perhaps more capable of improvement in both articles than any part of the British dominions in Europe. The inhabitants are so little skilled in husbandry, that the soil, though generally good in the low grounds, yields nothing but scanty crops of oats and barley; and great tracts of land lie together uncultivated. If a very small number of judicious farmers would settle in some of the most considerable islands, they would soon raise such harvests as would enrich themselves; employ and maintain all the idle people, a great number of whom are obliged to repair to foreign countries for subsistence; afford sufficient bread for the inhabitants, and even supply the barren parts of the opposite continent. The soil in many places would produce wheat, and almost everywhere would give good pasturage, in-so-much that, with proper culture, the people might provide hay and fodder for their cattle, which during the severity of the winter, die in great numbers for want of provision. Improvements of this kind would be the more easily made, as the sea-shore abounds with shells for lime and sea-weeds for manure; and the labourers would be easily subsisted by the fish that swarm not only in the ocean which surrounds these islands, but likewise in the numerous lakes and rivers of fresh water. Martin declares, that he knew 100 families in this country maintained by as many little farms, the rent of each not exceeding 5s. one sheep, and a few pecks of oats.

"The commerce of these islands might be extended in such a manner as to render them a staple of trade, and an excellent nursery for seamen. They are furnished

(A) In the beginning of the 17th century the islanders were continually harassing Ireland with their plundering invasions, or landing there to support rebellions: at length it was made treason to receive these Hebridian Redshanks as they were styled.

Hebrides. nished with an infinite number of bays, creeks, and harbours, for the convenience of navigation: the inhabitants are numerous, strong, active, and every way qualified for the life of a mariner. The sea affords myriads of fish for exportation: the lands might afford plenty of pasturage for black cattle, horses, and sheep, as well as plenteous harvests of corn and other grain: woollen and linen manufactures might be prosecuted to great advantage, where labour is cheap and provisions are reasonable. The islands afford good stone and lime; and some parts of the opposite main land, timber for building. They have plenty of fuel, not only for the ordinary purposes of life, but also for salt-pans, which might be erected on different parts of the coast; and for burning sea-ware for the use of a glass or soap manufacture. Finally, the situation of these islands is so commodious for trade, that the navigator is immediately in the open sea, and almost in the neighbourhood of Denmark, Sweden, Hamburg, Holland; nay, with a favourable wind, he can reach the coasts of France and Spain in a week's sailing: if he is bound for the British plantations, or indeed for any part of the known globe, he is at once disencumbered of the land, and prosecutes his voyage through the open sea without obstruction or difficulty."

To the neglected state of these islands, and to their great importance in various natural respects, the attention of government has been called within these few years by the representation and efforts of different patriotic noblemen and gentlemen, and a regular establishment has been formed under the name of the British Society for extending the Fisheries and improving the Sea-coasts of the Kingdom; in consequence of which many useful plans for the improvement of those islands have been adopted, and are gradually carrying into execution.

New HEBRIDES, a cluster of islands lying in the Great South sea, or Pacific ocean. The northern islands of this archipelago were first discovered by that great navigator Quiros in 1606, and not without reason considered as a part of the southern continent, which at that time, and till very lately, was supposed to exist. They were next visited by M. de Bougainville in 1768, who, besides landing on the island of Lepers, did no more than discover that the land was not connected, but composed of islands, which he called the *Great Cyclopes*. Captain Cook, besides ascertaining the extent and situation of these islands, added the knowledge of several in this group which were before unknown. He explored the whole cluster; and thinking himself thereby intitled to affix to them a general appellation, he named them the *New Hebrides*. They are situated between latitudes 14 deg. 25 min. and 20 deg. 4 min. south; and between 166 deg. 41. min. and 170 deg. 21 min. east longitude; and extend 125 leagues in the direction of north north-west and south-south-east. The most northern part of this archipelago was called by M. de Bougainville the *Peak of the Etoile*. The whole cluster consists of the following islands; some of which have received names from the different European navigators; others retain the names which they bear among the natives: viz. Tierra del Espiritu Santo, Mallicollo, St Bartholomew, isle of Lepers, Aurora, Whitsuntide, Ambrym, Immer, Apee, Three Hills, Sandwich, Montagn, Hinchin-

brook, Shepherd, Eorramanga, Ironnan, Annatom, and Tanna.

HFBRON, in *Ancient Geography*, a very ancient city, situated in the hilly country of the tribe of Judah to the south. Its more ancient name was *Kiriath Arba*, or *Cariath Arba*. In antiquity this city vied with most ancient cities of Egypt, being seven years prior to Zoan, translated *Tanis* by the Seventy. Josephus makes it not only older than Tanis, but even than Memphis. It stood to the west of the lake Asphalites, and was for some time the royal residence of David. After the captivity it fell into the hands of the Edomites, as did all the south country of Judah. It is now called *Habrown*, situated seven leagues to the south of Bethlehem. The Arabs call it *El-kalib*, "the well-beloved;" which is the epithet they usually apply to Abraham, whose sepulchral grotto they still shew. Habroun is seated at the foot of an eminence, on which are some wretched ruins, the misshapen remains of an ancient castle. The adjacent country is a sort of oblong hollow, five or six leagues in length, and not disagreeably varied by rocky hillocks, groves of fir-trees, stunted oaks, and a few plantations of vines and olive trees. These vineyards are not cultivated with a view to make wine, the inhabitants being such zealous Mahometans as not to permit any Christians to live among them: they are only of use to procure dried raisins, which are badly prepared, though the grapes are of an excellent kind. The peasants cultivate cotton likewise, which is spun by their wives, and sold at Jerusalem and Gaza. They have also some soap manufactures, the kali for which is sold them by the Bedouins; and a very ancient glass-house, the only one in Syria. They make there a great quantity of coloured rings, bracelets for the wrists and legs, and for the arms above the elbows, besides a variety of other trinkets, which are sent even to Constantinople. In consequence of these manufactures, Mr Volney informs us, Habroun is the most powerful village in all this quarter; and is able to arm 800 or 900 men, who adhere to the faction Kaisi, and are the perpetual enemies of the people of Bethlehem. This discord, which has prevailed throughout the country from the earliest times of the Arabs, causes a perpetual civil war. The peasants are incessantly making inroads on each other's lands, destroying their corn, dourra, sesamum, and olive trees, and carrying off their sheep, goats, and camels. The Turks, who are everywhere negligent in repressing similar disorders, are the less attentive to them here, since their authority is very precarious. The Bedouins, whose camps occupy the level country, are continually at open hostilities with them; of which the peasants avail themselves to resist their authority, or do mischief to each other, according to the blind caprice of their ignorance or the interest of the moment. Hence arises an anarchy which is still more dreadful than the despotism which prevails elsewhere, while the mutual devastations of the contending parties render the appearance of this part of Syria more wretched than that of any other.

HEBRUS, in *Ancient Geography*, the largest river of Thrace, rising from Mount Scombrus; running in two channels till it comes to Philippopolis, where they unite. It empties itself at two mouths into the Ægean sea, to the north of Samothrace. It was supposed to roll its waters upon golden sands. The head of Orphe-

Hebrus
|
Hecatombon.

us was thrown into it after it had been cut off by the Ciconian women.

HECATE, in fabulous history, a daughter of Perseus and Asteria, the same as Proserpine or Diana. She was called Luna in heaven, Diana on earth, and Hecate or Proserpine in hell; whence her name of *Diva triformis, tergemina, triiceps*. She was supposed to preside over magic and enchantments. She was generally represented like a woman, with the head of a horse, a dog, or a boar; and sometimes she appeared with three different bodies, and three different faces, with one neck. Dogs, lambs, and honey, were generally offered to her, especially in ways and cross roads; whence she obtained the name of *Trivia*. Her power was extended over heaven, the earth, sea, and hell; and to her kings and nations supposed themselves indebted for their prosperity.

HECATESIA, a yearly festival observed by the Stratonicensians in honour of Hecate. The Athenians paid also particular worship to this goddess, who was deemed the patroness of families and of children. From this circumstance the statues of the goddess were erected before the doors of the houses; and upon every new moon a public supper was always provided at the expence of the richest people, and set in the streets, where the poorest of the citizens were permitted to retire and feast upon it, while they reported that Hecate had devoured it. There were also expiatory offerings, to supplicate the goddess to remove whatever evils might impend on the head of the public, &c.

HECATOMB, in antiquity, a sacrifice of a hundred beasts of the same kind, at a hundred altars, and by a hundred priests or sacrificers. The word is formed of the Greek *ἑκατόμβη*, which properly signifies a sumptuous or magnificent sacrifice.—Others derive it from the Greek *ἑκατόν, centum*, "a hundred," and *βου, bos*, "bullock," &c.; on which footing the hecatomb should be a sacrifice of 100 bullocks.—Others derive the word from *ἄστρον* and *πῆξ, pes*, "foot;" and on that principle hold, that the hecatomb might consist of only 25 four-footed beasts. They add, that it did not matter what kind of beasts were chosen for victims, provided the quota of feet were but had.

Pythagoras is said to have sacrificed a hecatomb to the muses of 100 oxen, in joy and gratitude for his discovering the demonstration of the 47th proposition of the first book of Euclid, viz. that in a rectangled triangle the square of the hypotenuse is equal to the squares of the two other sides.

For the origin of hecatombs:—Strabo relates, that there were 100 cities in Laconia, and that each city used to sacrifice a bullock every year for the common safety of the country; whence the institution of the celebrated sacrifice of 100 victims, called *hecatombs*. Others refer the origin of hecatombs to a plague, wherewith the 100 cities of Peloponnesus were afflicted; for the removal whereof, they jointly contributed to so splendid a sacrifice.

Julius Capitolinus relates, that for a hecatomb they erected 100 altars of turf, and on these sacrificed 200 sheep and 100 hogs. He adds, that when the emperors offered sacrifices of this kind, they sacrificed 100 lions, 200 eagles, and 100 other beasts of the like kind.

HECATOMBÆON was the first month of the Athenian year, consisting of 30 days; beginning on the

first new moon after the summer solstice, and consequently answering to the latter part of our June and the beginning of July. It had its name from the great number of hecatombs sacrificed in it. See **HECATOMB**.

HECATOMPOLIS, in *Ancient Geography*, a surname of the island of Crete, from its 100 cities. The territory of Laconia also had anciently this name for the same reason; and the custom of these 100 cities was to sacrifice a hecatomb annually.

HECATOMPYLOS, in *Ancient Geography*, the metropolis of Parthia, and royal residence of Arsaces, situated at the springs of the Araxes. Thebes in Egypt had also the same name from its 100 gates.

HECK, an engine to take fish. A salmon beck is a grate for catching that sort of fish.

HECKLE, among hemp-dressers. See **HATCHEL**.

HECLA, a volcano of Iceland, and one of the most furious in the world, situated in the southern part of the island. See **ICELAND**.

It was visited in the year 1772 by Dr Van Troil, a Swedish gentleman, along with Mr (now Sir Joseph) Banks, Dr Solander, and Dr James Lind of Edinburgh. On their first landing they found a tract of land 60 or 70 miles in extent entirely ruined by lava, which appeared to have been in the highest state of liquefaction. Having undertaken a journey to the top of the mountain, they travelled 300 or 360 English miles over an uninterrupted tract of lava; and had at length the pleasure of being the first who had arrived at the summit of the mountain.

Hecla, according to the accounts of these gentlemen, is situated in the southern part of the island, about four miles from the sea-coast, and is divided into three parts at the top, the middle point being the highest; and, according to an exact observation with Ramsden's barometer, is 5000 feet above the level of the sea. They were obliged to quit their horses at the first opening from which the fire had burst. They describe this as a place with lofty glazed walls and high glazed cliffs, unlike any thing which they had ever seen before.

A little higher up they found a large quantity of grit and stones; and still farther on another opening, which, though not deep, descended lower than that of the highest point. Here they imagined they plainly discerned the effects of boiling water; and not far from thence the mountain began to be covered with snow, excepting some spots which were bare. The reason of this difference they soon perceived to be the hot vapour ascending from the mountain. As they ascended higher they found these spots become larger; and about 200 yards below the summit, a hole about a yard and a half in diameter was observed, from whence issued so hot a steam, that they could not measure the degree of heat with the thermometer. The cold now began to be very intense; Fahrenheit's thermometer, which, at the foot of the mountain was at 54, now fell to 24; the wind also became so violent, that they were sometimes obliged to lie down for fear of being blown down the most dreadful precipices. On the very summit they experienced at the same time a high degree of heat and cold; for, in the air, Fahrenheit's thermometer stood constantly at 24, but when set on the ground, rose to 153: the barometer stood at 22.247. Though they were

Hecatombon.
|
Hecla.

Hecla. were very much inclined to remain here for some time, it could by no means be done with safety; for which reason they were obliged to descend very quickly.

The mountain seems to be made up, not of lava, but of sand, grit, and ashes; which are thrown up with the stones partly discoloured, and partly melted by the fire. Several sorts of pumice stones were found on it, among which was one with some sulphur. Sometimes the pumice was so much burnt, that it was as light as tow. Its form and colour was sometimes very fine, but at the same time so soft, that it was difficult to remove it from one place to another. The common lava was found both in large pieces and small bits; as likewise a quantity of black jasper burned at the extremities, and resembling trees and branches. Some slate of a strong red colour was observed among the stones thrown out by the volcano. In one place the lava had taken the form of chimney-stacks half broken down.—As they descended the mountain they observed three openings. In one, every thing looked as red as brick; from another, the lava had flowed in a stream about 50 yards broad, and after proceeding for some way, had divided into three large branches. Further on they perceived an opening, at the bottom of which was a mount in form of a sugar-loaf, in throwing up of which the fire appeared to have exhausted itself.

We have already observed, that our travellers were the first who ascended to the top of this mountain. The reason that no one before them had ever done so was partly founded in superstition, and partly the steepness and difficulty of the ascent, which was greatly facilitated by an eruption in 1766. Most kinds of lava found in other volcanic countries are to be met with about Hecla, or other Iceland volcanoes; as the gray, dark perforated kind, similar to the Derbyshire loadstone; and the Iceland agate, *pumex vitreus*, both the *niger* and *viridis*. Some have conjectured this to be the *lapis obsidianus* of the ancients, which they formed into statues.

The lava is seldom found near the openings whence the eruptions proceed, but rather loose grit and ashes; and indeed the greater part of the Icelandic mountains consist of this matter; which, when it is grown cold, generally takes an arched form. The upper crust frequently grows hard and solid, whilst the melted matter beneath it continues liquid. This forms great cavities, whose walls, bed, and roof, are of lava, and where great quantities of stalactite lava are found. There are a vast number of these caves in the island, some of which are very large, and are made use of by the inhabitants for sheltering their cattle. The largest in the island is 5034 feet long, and from 50 to 54 in breadth, and between 34 and 36 in height.—There are some prodigious clefts left by the eruptions, the largest of which is called *Almenegga*, near the water of Thingalla, in the south-western part of the island. It is 105 feet broad and very long. The direction of the chasin itself is from north to south. Its western wall, from which the other has been perpendicularly divided, is 107 feet six inches in height, and consists of many strata, of about 10 inches each in height, of lava grown cold at different times. The eastern wall is only 45 feet 4 inches in height, and that part of it which is directly opposite to the highest part of the other side is no more than 36 feet 5 inches high.

HECTIC FEVER. See *MEDICINE Index*.

HECTOR, the son of Priam and Hecuba, and the father of Astyanax, is celebrated for the valour with which he defended the city of Troy against the Greeks. He was killed by Achilles, who dragged his body, fastened to his chariot, thrice round the walls of Troy, and afterwards restored it to Priam for a large ransom. See *TROY*.

HEDERA, *IVY*, a genus of plants belonging to the pentandria class; and in the natural method giving name to the 46th order, *Hederaceæ*. See *BOTANY Index*.

HEDERACEÆ (from *hedera*, "ivy"), the name of the 46th order in Linnæus's fragments of a natural method, consisting of ivy, and a few other genera, which from their general habit and appearance seem nearly allied to it. See *BOTANY Index*.

HEDGES, in *Agriculture*, are either planted to make fences round enclosures, or to divide the several parts of a garden. When they are designed as outward fences, they are planted either with hawthorn, crabs, or black-thorn; but those hedges which are planted in gardens, either to surround wilderness-quarters, or to screen the other parts of a garden from sight, are planted according to the fancy of the owner; some preferring evergreens, in which case the holly is best; next the yew, then the laurel, laurustinus, phyllyrea, &c. Others prefer the beech, the hornbeam, and the elm. See *AGRICULTURE* and *GARDENING*.

HEDGE-Hog. See *ERINACEUS*, *MAMMALIA Index*.

HEDGE-Sparrow. See *MOTACILLA*, *ORNITHOLOGICAL Index*.

HEDWIG, *JOHN*, a botanist of great eminence, was born at Cronstadt in Transylvania, in October 1730, of a family originally Saxon. In his earliest years he discovered a strong attachment to the study of botany, in which he afterwards excelled so much. He was left with very little to support him on the death of his father. The fame of Gerlach led him to Zittau in Lusatia, where he prosecuted his studies for three years, assisted by the generosity of different benefactors. He studied philosophy, mathematics, and medicine, at Leipsic, where he was distinguished for his diligence and regularity of deportment. He afterwards assisted Ludwig in the regulation of his library, anatomical museum and botanical garden; and in 1756, he entered into the family of Bose, professor of botany, for whom he prepared plants for demonstration, and attended patients in the public infirmary. In 1759 he took the degree of M. D. and practised at Chemnitz in Saxony, where he entered into the married state.

It was customary with him to walk the fields by five in the morning to contemplate the beauties of nature, to visit his patients after breakfast, and spend the afternoon and evening in examining such plants as he had collected during his early excursions. He particularly applied himself to the investigation of the grasses, and also of the whole cryptogamia class of plants, which botanists at that period had greatly neglected. At the age of 40, he taught himself to draw and paint the objects which he had discovered, and the compound microscope which he received from Koehler of Dresden, greatly assisted him in those researches. By the persuasion of his second wife (whom he married about a year

Hectic

Fever

Hedwig

Hedwig
Heel.

after the death of his first), he was prevailed with to settle at Leipsic in 1781, where he published his great work, entitled, *Fundamentum Historiæ Naturalis Muscorum Frondosorum*. In this he gave an accurate history of mosses from his own observations, and illustrated the whole with appropriate plates. In it he discovered such sagacity, industry, and profound research, as astonished all the botanists of his time, and induced them to pay more attention to this curious subject. He gained the prize given by the Petersburg academy for his curious and excellent treatise *Theoria Generationis et Fructificationis Plantarum Cryptogamicarum, Linnæi more, propriis Observationibus et Experimentis Superstructa*, published in 1784.

His literary reputation increased his medical practice; he was chosen physician to the town guards in the last mentioned year, and two years after he became professor of medicine in the university. In 1789, he was chosen ordinary professor of botany, and superintended the physio garden. He corrected the false notions which then prevailed, respecting the efficacy of the medulla or pith, the perforation of the flowers, the excrements of plants, the increase of the vessels of vegetables, and the genuine use of the leaves. By the death of a favourite daughter of a consumption at 16 years of age, he received a severe shock; and a catarrhal affection, followed by a nervous fever, deprived the world of that great man on 7th of February 1799, in the 68th year of his age.

It is agreed on all hands, that Dr Hedwig was a man of great modesty, the usual concomitant of extraordinary talents; that he was friendly and benevolent, upright in his dealings, not solicitous about wealth, and free from parade, both in teaching and in writing. In the forests of Hispaniola there is an evergreen tree, the name of which, *hedwigia balsamifera*, was intended in the most honourable manner to perpetuate his memory. He left behind him two sons, one a painter of eminence at Magdeburg, and the other Dr Romanus Adolphus Hedwig, already known to the botanical world by several publications.

HEDWIGIA, a genus of plants belonging to the class octandria; and in the natural method arranged with the *Trikilatæ*. See **BOTANY Index**.

HEDYCARYA, a genus of plants belonging to the diœcia class. See **BOTANY Index**.

HEDYOTIS, a genus of plants belonging to the tetrandria class of plants; and in the natural method ranking under the 47th order, *Stellatæ*. See **BOTANY Index**.

HEDYSARUM, a genus of plants belonging to the diadelphia class of plants; and in the natural method ranking under the 32d order, *Papilionacæ*. See **BOTANY Index**.

HEEL, in *Anatomy*, the hind part of the foot. See **ANATOMY**, N^o 66.

HEEL of a Horse, the lower hinder-part of the foot comprehended between the quarters and opposite to the toes. The heel of a horse should be high and large, and rising equally upon the pastern.

HEEL of a Horseman. This being the part that is armed with the spur, the word is used for the spur itself: "This horse understands the heel well." To ride a horse from one heel to another, is to make him

go sideways sometimes to one heel and sometimes to another.

HEEL, in the sea-language. If a ship leans on one side, whether she be aground or afloat, then it is said she heels a-starboard, or a-port; or that she heels off-wards, or to the shore; that is, inclines more to one side than to another.

HEELER, or *Bloody-HEEL Cock*, a fighting cock, that strikes or wounds much with his spurs.

The masters know such a cock, even while a chicken, by the striking of his two heels together in his going.

HEEMSKIRK. See **HEMSKIRK**.

HEGIRA, in *Chronology*, a celebrated epoch among the Mahometans. The word is Arabic, formed of *هجر*, *hagirah*, "flight;" of *وطن*, "to fly, quit one's country, family, friends," &c.

The event which gave occasion to this epocha, was Mahomet's flight from Mecca. The magistrates of that city, fearing his impostures might raise a sedition, resolved to expel him: this, accordingly, they effected in the year of our Lord 633, on the evening of the 12th or 16th of July. See **ARABIA**, N^o 44.

To render this epocha more creditable, the Mahometans affect to use the word *hegira* in a peculiar sense for an act of religion, whereby a man forsakes his country, and gives way to the violence of persecutors and enemies of the faith: they add, that the Corashites, being then the strongest party in the city, obliged their prophet to fly, as not being able to endure his abolishing of idolatry. This flight was not the first of Mahomet's, but it was the most famous. It happened in the 14th year from his assuming the character of prophet and apostle, and promulgating his new religion.

The orientals do not agree with us as to the time of the hegira. Among the Mahometans, Amasi fixes it to the year of Christ 630, and from the death of Moses 2347; and Ben Cassem to the year of the world 5800: according to the Greek computation, among the Christians, Said Ebn Batrik refers the hegira to the year of Christ 614, and of the creation 6114.

Khondemir relates, that it was Omar, the second caliph, that first established the hegira as an epocha, and appointed the years to be numbered from it: at the time he made this decree, there were already seven years elapsed. This establishment was made in imitation of the Christians, who, in those times, reckoned their years from the persecution of Dioclesian.

But there is another hegira, and that earlier too, though of less eminence. Mahomet, in the 14th year of his mission, was obliged to relinquish Medina: the Corashites had all along opposed him very vigorously, as an innovator and disturber of the public peace; and many of his disciples, not enduring to be reputed followers of an impostor, desired leave of him to abandon the city, for fear of being obliged to renounce their religion. This retreat makes the first hegira. These two hegiras the Mahometans, in their language, call *hegiranat*.

The years of the hegira consist only of 354 days. To reduce these years to the Julian calendar, i. e. to find what Julian year a given year of the hegira answers to, reduce the year of the hegira given into days, by multiplying by 354, divide the product by

365;

Hegira, 365, and from the quotient subtract the intercalations, i. e. as many days as there are four years in the quotient; and lastly, to the remainder add 622. See YEAR.

HEIDEGGER, JOHN JAMES, was the son of a clergyman, and a native of Zurich in Switzerland, where he married, but left his country in consequence of an intrigue. Having had an opportunity of visiting the principal cities of Europe, he acquired a taste for elegant and refined pleasures, as they are called, which, united to a strong inclination for voluptuousness, by degrees qualified him for the management of public amusements. In 1708, when he was near 50 years old, he came to England on a negotiation from the Swiss at Zurich; but, failing in his embassy, he entered as a private soldier in the guards for protection. By his sprightly engaging conversation and insinuating address, he soon worked himself into the good graces of our young people of fashion; from whom he obtained the appellation of *the Swiss Count*. He had the address to procure a subscription, with which, in 1709, he was enabled to furnish out the opera of "Thomyris," which was written in English, and performed at the queen's theatre in the Haymarket. The music, however, was Italian; that is to say, airs selected from sundry of the foreign operas by Bunoncini, Scarlatti, Stefani, Gasparini, and Albinoni. Heidegger by this performance alone was a gainer of 500 guineas. The judicious remarks he made on several defects in the conduct of our operas in general, and the hints he threw out for improving the entertainments of the royal theatre, soon established his character as a good critic. Appeals were made to his judgment; and some very magnificent and elegant decorations introduced upon the stage in consequence of his advice, gave such satisfaction to George II. who was fond of operas, that, upon being informed to whose genius he was indebted for those improvements, his majesty was pleased from that time to countenance him, and he soon obtained the chief

management of the opera-house in the Haymarket. He then set about improving another species of diversion, not less agreeable to the king, which was the masquerades, and over these he always presided at the king's theatre. He was likewise appointed master of the revels. The nobility now caressed him so much, and had such an opinion of his taste, that all splendid and elegant entertainments given by them upon particular occasions, and all private assemblies by subscriptions, were submitted to his direction. From the emoluments of these several employments, he gained a regular considerable income, amounting, it is said, in some years, to 5000*l.* which he spent with much liberality, particularly in the maintenance of a somewhat too luxurious table; so that it may be said he raised an income, but never a fortune. At the same time his charities ought not to pass unnoticed, which were frequent and ample. After a successful masquerade, he has been known to give away several hundred pounds at a time. "You know poor objects of distress better than I do," he would frequently say to a particular acquaintance; "be so kind as to give away this money for me." This well-known liberality, perhaps, contributed much to his carrying on that diversion with so little opposition as he met with. He died in 1749, at the advanced age of 90 years.

As this person was long the *Arbiter Elegantiarum* of England, and is alluded to in many publications of his time, some account of him, it was thought, might be here expected; but to add all the anecdotes that have appeared concerning him, would enlarge this article beyond the limits to which it is entitled. One or two of the most remarkable, however, are subjoined in a note (A), as they may afford entertainment to many of our readers.

HEIDENHEIM, a town of Germany, in Swabia, and in the territory of Brentzhall, with a handsome palace or castle, belonging to the house of Wirtemberg. E. Long. 10. 19. N. Lat. 48. 37.

HEIDELBERG,

(A) Heidegger's countenance was peculiarly displeasing, from an unusual harshness of features. There is a mezzotinto of him by J. Faber, 1742, from a painting by Vanloo, a striking likeness, and his face is introduced in more than one of Hogarth's prints.—Heidegger was, however, the first to joke upon his own ugliness; and he once laid a wager with the earl of Chesterfield, that within a certain given time his lordship would not be able to produce so hideous a face in all London. After strict search, a woman was found, whose features were at first sight thought stronger than Heidegger's; but upon clapping her head-dress upon himself, he was universally allowed to have won the wager. Jolly, a well-known taylor, carrying his bill to a noble duke; his grace, for evasion, said, "Damn your ugly face, I never will pay you till you bring me an uglier fellow than yourself!" Jolly bowed and retired, wrote a letter, and sent it by a servant to Heidegger; saying, "His grace wished to see him the next morning on particular business." Heidegger attended, and Jolly was there to meet him; and in consequence, as soon as Heidegger's visit was over, Jolly received the cash.

The late facetious duke of Montagu (the memorable author of the *Bottle Conjurer* at the theatre in the Haymarket) gave an entertainment at the Devil-tavern, Temple-bar, to several of the nobility and gentry, selecting the most convivial, and a few hard drinkers, who were all in the plot. Heidegger was invited, and in a few hours after dinner was made so dead drunk that he was carried out of the room, and laid insensible upon a bed. A profound sleep ensued; when the late Mrs Salmon's daughter was introduced, who took a mould from his face in plaster of Paris. From this a mask was made, and a few days before the next masquerade (at which the king promised to be present, with the countess of Yarmouth) the duke made application to Heidegger's valet-de-chambre, to know what sort of clothes he was likely to wear; and then procuring a similar dress, and a person of the same stature, he gave him his instructions. On the evening of the masquerade, as soon as his majesty was seated (who was always known by the conductor of the entertainment and the officers of the court, though concealed by his dress from the company), Heidegger, as usual, ordered the music to play "God save the king;" but his back was no sooner turned, than the false Heidegger ordered them to strike up "Charly o'er the water." The whole

Heidelberg.
Height.

HEIDELBERG, a considerable and populous town of Germany, subject to the Grand Duke of Baden, with a celebrated university. It is noted for its great tun, which holds 800 hogsheads, generally kept full of good Rhenish wine. It stands in a pleasant rich country, and was a famous seat of learning. It was first reduced to a heap of ruins in 1622 by the Spaniards; and the rich library was transported partly to Vienna, and partly to the Vatican at Rome. After this it enjoyed the benefits of peace, till the Protestant electoral house became extinct, and a bloody war ensued, in which not only the castle was ruined, but the tombs and bodies of the electors were shamefully violated and pillaged. This happened in 1693; and the people of the Palatinate were obliged to leave their dwellings, and to go for refuge into foreign countries. To add to these misfortunes, the elector resided at Manheim, and carried most of the people of distinction along with him. The great tun was broken to pieces in 1693 by the French, and at great expence in 1729 was repaired. The town stands on the river Neckar, over which there is a handsome bridge. The town having been annexed to Baden by Bonaparte, its university was patronised by the new government, and has now 26 professors, with 500 or 600 students. The library is large, and very rich in manuscripts. E. Long. 8. 48. N. Lat. 49. 25.

HEIGHT, in general, signifies the difference between the ground and the top of any object measured perpendicularly.

Methods of Measuring HEIGHTS. See **MENSURATION** and **BAROMETER**.

HEILA, a town of Royal Prussia, in Cassubia, seated at the mouth of the river Vistula, on the Baltic sea, and formerly subject to Poland, 12 miles north of Dantzic. E. Long. 19. 25. N. Lat. 54. 53.

HEILEGEN-HAVE, a sea-port town of Germany, in Lower Saxony, and in Wageria, seated on the Baltic sea, over against the island of Termeren. E. Long. 11. 15. N. Lat. 57. 30.

HEINECCIUS, JOHN GOTTLIEB, one of the greatest civilians of the 18th century, was born at Eisenberg, in the principality of Altenburg, in 1681. After having studied at Goslar and Leipsic, he was designed for the ministry, and began to preach; but disliking that profession, he laid it aside, and applied himself entirely to the study of philosophy and the civil law. In 1710, he became professor of philosophy at Hall; and in 1721, he was made professor of civil law, with the title of *counsellor of the court*. His great reputation made the states of Friesland invite him to Francker in 1724; but three years after, the king of Prussia prevailed on him to accept of a professorship of law at Francfort on the Oder, where he distinguished himself till the year 1733. Becoming again professor at Hall, he remained there till his death, which happened in 1741, notwithstanding his being invited to Marburg, Denmark, and three academies in Holland. He wrote many works, all of them much esteemed. The principal are, 1. *Antiquitatum Romanarum jurisprudentiam illustrantium syntagma*. It was this excellent abridgement that gave rise to his reputation in foreign countries. 2. *Elementa juris civilis secundum ordinem institutionum et pandectarum*. 3. *Fundamenta styli cultioris*. There are few works

Heila
Heineccium.

company were instantly thunderstruck, and all the courtiers not in the plot were thrown into a stupid consternation. Heidegger flew to the music-gallery, swore, stamped, and raved, accusing the musicians of drunkenness, or of being set on by some secret enemy to ruin him. The king and the countess laughed so immoderately, that they hazarded a discovery. While Heidegger staid in the gallery, "God save the king" was the tune; but when, after setting matters to rights, he retired to one of the dancing rooms, to observe if decorum was kept by the company, the counterfeit stepping forward, and placing himself upon the floor of the theatre, just in front of the music gallery, called out in a most audible voice, imitating Heidegger, damned them for blockheads, had he not just told them to play "Charly o'er the water?" A pause ensued; the musicians, who knew his character, in their turn thought him either drunk or mad; but as he continued his vociferation, "Charly" was played again. At this repetition of the supposed affront, some of the officers of the guards, who always attended upon these occasions, were for ascending the gallery and kicking the musicians out; but the late duke of Cumberland, who could hardly contain himself, interposed. The company were thrown into great confusion. "Shame! Shame!" resounded from all parts, and Heidegger once more flew in a violent rage to that part of the theatre facing the gallery. Here the duke of Montagu, artfully addressing himself to him, told him, "The king was in a violent passion; that his best way was to go instantly and make an apology, for certainly the musicians were mad, and afterwards to discharge them. Almost at the same instant, he ordered the false Heidegger to do the same. The scene now became truly comic in the circle before the king. Heidegger had no sooner made a genteel apology for the insolence of his musicians, but the false Heidegger advanced, and in a plaintive tone, cried out, "Indeed, Sire, it was not my fault but that devil's in my likeness." Poor Heidegger turned round, stared, staggered, grew pale, and could not utter a word. The duke then humanely whispered in his ear the sum of his plot, and the counterfeit was ordered to take off his mask. Here ended the frolic; but Heidegger swore he would never attend any public amusement, if that witch the wax-work woman did not break the mould, and melt down the mask before his face.

Being once at supper with a large company, when a question was debated, Which nationalist of Europe had the greatest ingenuity? to the surprise of all present, he claimed that character for the Swiss, and appealed to himself for the truth of it. "I was born a Swiss (said he), and came to England without a farthing, where I have found means to gain 5000l. a-year, and to spend it. Now I defy the most able Englishman to go to Switzerland, and either to gain that income or to spend it there."—Heidegger is said to have had so remarkable a memory, that he once walked from Charing-cross to Temple-bar, and back again; and when he came home, wrote down every sign on each side of the street.

Heinecius works so useful as this for forming a Latin style. 4. *Elementa philosophiæ rationalis et moralis, quibus præmissa historia philosophica.* 5. *Historia juris civilis Romani ac Germanici.* 6. *Elementa juris naturæ et gentium, &c.*

Heir-loom.

noting *limb* or *members*) in our law-books, signifies such goods and personal chattels as are not inventoried after the owner's decease, but necessarily come to the heir along with the house.

Heir-loom
Helena.

HEINETKEN, CHRISTIAN, an extraordinary child, the prodigy of the North, was born at Lubeck in 1721. He spoke his maternal tongue fluently at ten months. At one year old, he knew the principal events of the Pentateuch; in two months more, he was master of the entire history of the Old and New Testaments; at two years and a half, he answered the principal questions in geography and in ancient and modern history; and he spoke Latin and French with great facility before the commencement of his fourth year. His constitution was so delicate, that he was not weaned till a few months before his death. M. Martini of Lubeck published a pamphlet in 1730, in which he endeavoured to give natural reasons for the extraordinary capacity of this infant, who died in his fifth year.

HEINSIUS, DANIEL, professor of politics and history at Leyden, and librarian to the university there, was born at Gand in Flanders in 1580. He became a scholar to Joseph Scaliger at Leyden, and was indebted to the encouragement and care of that great man for the perfection to which he attained in literature, and which at the beginning of his life there was little reason to hope from him. He distinguished himself as a critic by his labours on many classical authors; and was highly honoured as well abroad as at home: Gustavus Adolphus king of Sweden, gave him a place among his counsellors of state; the republic of Venice made him a knight of the order of St Mark; and Pope Urban VIII. made him great offers, if he would come, as he expressed it, "to rescue Rome from barbarism." He died in 1669, leaving several works of his own, both in poetry and prose.

HEINSIUS, *Nicholas*, the son of Daniel Heinsius, was born at Leyden; and became as great a Latin poet, and a greater critic, than his father. His poems have been several times printed, but the best edition is that of Amsterdam in 1666. He gave editions of several of the classics, with notes; his *Claudian* is dedicated in a Latin poem to Queen Christina of Sweden, and his *Ovid* to Thuanus. At his death, which happened in 1681, he disclaimed all his works, and expressed the utmost regret at having left behind him so many "monuments of his vanity," as he called them. He was as much distinguished by his great employments in the state, as by his talents, learning, and good qualities.

HEIR, in *Law*, signifies the person who succeeds another by descent to lands, tenements, and hereditaments, being an estate of inheritance, or an estate in fee; because nothing passes by right of inheritance but in fee. See the articles *CONSANGUINITY*, *DESCENT*, *FEU*, *SUCCESSION*, and *LAW Index*.

HEIR-*Apparent*, is a person so called in the lifetime of his ancestor, at whose death he is heir at law.

HEIR-*Presumptive*, is one who, if the ancestor should die immediately, would, in the present circumstances of things, be his heir; but whose right of inheritance may be defeated by the contingency of some nearer heir being born.

HEIR-*Loom* (formed of heir and the Saxon *loom*, de-
VOL. X. Part I. †

Heir-loom comprehends divers implements; as tables, presses, cupboards, bedsteads, furnaces, wainscot, and such like; which in some countries have belonged to a house for certain descents, and are never inventoried after the decease of the owner, as chattels are, but accrue by custom, not by common law, to the heir, with the house itself. The ancient jewels of the crown are held to be heir-loom, and are not devisable by will, but descend to the next successor.

HEIRESS, a female heir to one who has an estate in lands, &c. See HEIR.

Stealing an HEIRESS. See *FORCIBLE Marriage*.

HEIRSHIP MOVEABLES, in *Scots Law*, the best of certain kinds of moveables, which the heir of line is entitled to take, besides the heritable estate. See *LAW Index*.

HEISTER, LAURENCE, an eminent physician, surgeon, and anatomist, was born at Frankfort on the Mayne, in the year 1683. After being educated in the universities of Germany, he prosecuted the study of anatomy and surgery at Amsterdam, in 1706. Next year he acted as surgeon in the Dutch camp in Brabant, and afterwards studied medicine at Leyden under the celebrated Boerhaave, at the expiration of which he took his degrees. In 1709, he was appointed physician-general to the Dutch military hospital, by which means he acquired vast experience, both in medicine and surgery. He was appointed professor of anatomy and surgery at Altdorf in 1710, where he acquired great celebrity by his lectures and writings.

In 1720 he removed to the university of Helmstadt, where he continued during the remainder of his life. The czar Peter invited him to Russia; but the esteem in which he was held by different sovereigns induced him to remain in Germany. His death happened in the year 1758, in the 75th year of his age. Dr Heister was uncommonly industrious, and wrote a prodigious number of books; but his principal fame was derived from his singular skill and success in surgery. He is particularly known by his *Compendium Anatomicum*, which has been frequently reprinted, and translated into different languages. The chief of his surgical publications is his *Institutions of Surgery*, which was long considered as a standard book of the kind, till it was superseded by more modern systems. As a physician his principal works are, *Observationes Medico-miscellaneæ*, *Theoreticæ et Practicæ*; *De Medicinæ Mechanicæ Prestantia*; and *Compendium Institutionum et Fundamentorum Medicinæ*. A collection of Medical, Chirurgical, and Anatomical Observations, was published after his death in 2 vols quarto.

HEISTERIA, a genus of plants belonging to the decandria class; and in the natural method ranking under the 12th order, *Holoracæ*. See *BOTANY Index*.

HELENA, or ST HELENA, an island in the Atlantic ocean, belonging to the English East India Company, and situated in W. Long. 6. 30. S. Lat. 16. The greatest length of the island is about eight miles, and its circumference is above 20. Some of the mountains are pretty high, covered with wood to the top, and exhibit marks of volcanic eruptions. The country

Helena. try, according to Mr Forster, has a fine appearance; the soil is in many places a rich mould, from six to ten inches deep, and a variety of plants thrive in it luxuriantly. He found many plants here which he had not observed in any other parts of the world. Among these were some called by the natives *cabbage-trees*, *gum-trees*, and *red wood*. The former thrive in moist places; but the latter are always found on the ridges of hills, where the soil is dry. The cabbage-tree has rather large leaves; but after many inquiries Mr Forster could not find that it was used for any other purpose than that of fuel, and no reason could be assigned why it had obtained that name. It must not be confounded with the cabbage-tree of America, India, and the South seas, which is a species of palm.

This island is laid out entirely in gardens and pasture. Besides peaches, we are assured that the plantain and banana thrive here remarkably well. Cabbages, and other greens, which thrive extremely well, are devoured by caterpillars; and every species of corn is destroyed by rats. All the pastures were overrun with furze; which, though in our country a very useless and even pernicious plant, was of singular advantage to the inhabitants of St Helena. Before the introduction of that plant, the ground was parched with the intense heat, and all kinds of grass and herbage were shrivelled up. But the furze-bushes, which thrive as it were in despite of the sun, preserved a degree of moisture in the ground; by which means the grass sprung up vigorously, and the country became covered with a rich and beautiful sod. The furze is now no longer wanted, and the people assiduously root it out for fuel. The number of people on St Helena does not exceed 2000 persons, including 500 soldiers, and 600 slaves; and it is said that the number of females born on the island considerably exceeds that of the males. By the arrival of the India ships, which they supply with refreshments, they are in return provided with all sorts of manufactures and other necessaries; and the company annually order one or two of their ships to touch there in their way to India, in order to send them a sufficient quantity of European goods and provisions. Many of their slaves are employed in catching fish, which are very plentiful; and by the help of these, together with their poultry, cattle, roots, and salt provisions, they subsist through the year. Their life (says Mr Forster) seems to pass along very happily; free from the multitude of cares which distress their countrymen in England, and blessed with quiet and content.

A botanic garden has been established near the country house of the governor, and a well-informed gardener sent by the company to take care of it. The sea around the island abounds with esculent fishes, 70 different species of which have been taken upon the coasts. There are great numbers of whales around the island, where the southern whale fishery, it is believed, might be carried on with great advantage to the nation.

The country, in general, is cultivated by slaves; but as these are now placed under the protection of the magistracy, and various regulations enacted in their favour, they may comparatively be said to be comfortable and secure. Before these regulations took place, ten out of a hundred were known to die annually, whereas they are now on the increase, and the expences occasioned

by the replacing of those who died formerly are thus avoided.

There are some blacks who are in a state of freedom, independent of the slaves. These, at first, were obnoxious to the slave owners; but, upon examination, it was found that not one of them had been tried for a crime for several years, nor had any of them been upon the parish. By the humane interference of the company they share the protection of the government, and are almost on a footing with the other free inhabitants, having the benefit of a jury when accused of crimes, as well as in civil cases.

This country is so fertile, and the climate so exactly suited to the feelings of human nature, that persons indifferent to the enjoyments of the world, or far advanced in years, could scarcely find another spot better calculated to prolong their existence in ease, health, and comfort.

St Helena was first discovered by the Portuguese in 1502, on St Helen's day; whence its name. They stocked it with different kinds of useful animals; but whether they ever settled a colony on it or not, is uncertain. The Portuguese having either abandoned or never taken possession of it, the Dutch became its masters; and kept possession of it till the year 1600, when they were driven out by the English. In 1673, the Dutch took it by surprise; but a short time after it was recovered by the brave Captain Munden, who also took three Dutch East Indiamen then lying in the harbour. On this occasion the Hollanders had fortified the landing place, of which there is only one on the island; and erected batteries of great guns to prevent a descent: but the English having knowledge of a small creek, where only two men abreast could creep up, climbed to the top of the rock in the night; and appearing the next morning behind the batteries, the Dutch were so terrified, that they threw down their arms, and surrendered at discretion. This creek has been since fortified, and a battery of large cannon placed at the entrance of it; so that now the island is rendered perfectly secure against all regular approaches or sudden attacks.

St Helena has lately acquired no small celebrity as the place of confinement of Napoleon Bonaparte, late emperor of France. The illustrious exile arrived here on the 17th October 1815, and remained in the island till his death, 5th May 1821. He was buried in a retired spot not far from Longwood, the place of his residence.

HELEN, in fabulous history, the daughter of Tyndarus and Leda, was married to Menelaus, king of Sparta, but was stolen from him by Theseus, 1235 B. C. She was restored soon after; but carried off again by Paris, the Trojan prince; which occasioned the famous Trojan war. See TROY.

ST HELEN'S. See HELLEN'S.

HELENIUM, BASTARD SUN-FLOWER; a genus of plants belonging to the syngenesia class; and in the natural method ranking under the 49th order, *Composita*. See BOTANY Index.

HELENUS, in fabulous history, a celebrated soothsayer, son of Priam and Hecuba. He was greatly respected by all the Trojans. When Deiphobus was given in marriage to Helen in preference to himself, he resolved to leave his country, and retired to Mount Ida, where Ulysses took him prisoner by the advice of Calchas. As he was well acquainted with futurity, the

Helena
||
Helenus.

Helena | **Helianthus** | Greeks made use of prayers, threats, and promises, to induce him to reveal the secrets of the Trojans; and either the fear of death, or gratification of resentment, seduced him to disclose to the enemies of his country, that Troy could not be taken whilst it was in possession of the palladium, nor before Polydectes came from his retreat at Lemnos and assisted to support the siege. After the ruin of his country, he fell to the share of Pyrrhus the son of Achilles, and saved his life by warning him to avoid a dangerous tempest, which in reality proved fatal to all those who set sail. This endeared him to Pyrrhus; and he received from his hand Andromache the widow of his brother Hector, by whom he had a son called *Cestrinus*. This marriage, according to some, was consummated after the death of Pyrrhus, who lived with Andromache as with a wife. Helenus was the only one of Priam's sons who survived the ruin of his country. After the death of Pyrrhus he reigned over part of Epirus, which he called *Chaonia* in memory of his brother Chaon, whom he had inadvertently killed. Helenus received Æneas as he voyaged towards Italy, and foretold him some of the calamities which attended his fleet. The manner in which he received the gift of prophecy is doubtful.

HELEPOLIS, in the ancient art of war, a machine for battering down the walls of a place besieged, the invention of which is ascribed to Demetrius Poliorcetes.—Diodorus Siculus says, that each side of the Helepolis was 405 cubits in breadth and 90 in height; that it had nine stages, and was carried on four strong solid wheels eight cubits in diameter; that it was armed with large battering rams, and had two roofs capable of supporting them; that in the lower stages there were several sorts of engines for casting stones; and in the middle they had large catapultas for discharging arrows, and smaller ones in those above, with a number of expert men for working all these machines.

HELIADES, in *Mythology*, the daughters of the Sun and Clymenes, according to the poets. They were so afflicted, as they say, with the death of their brother Phaeton, that the gods, moved with compassion, transformed them into poplars on the banks of the river Eridanus.

HELIAEA, in Grecian antiquity, was the greatest and most frequented court in Athens for the trial of civil affairs. See **HELIASTÆ**.

HELIACAL, in *Astronomy*, a term applied to the rising and setting of the stars; or, more strictly speaking, to their emersion out of and immersion into the rays and superior splendour of the sun.—A star is said to rise heliacally, when, after having been in conjunction with the sun, and on that account invisible, it comes to be at such a distance from him as to be seen in the morning before sunrise; the sun, by his apparent motion, receding from the star towards the east. On the contrary, the heliacal setting is when the sun approaches so near a star as to hide it with his beams, which prevent the fainter light of the star from being perceived; so that the terms *apparition* and *occultation* would be more proper than *rising* and *setting*.

HELIANTHUS, the GREAT SUNFLOWER; a genus of plants belonging to the syngenesia class; and in the natural method ranking under the 46th order, *Compositæ*. See **BOTANY Index**.

HELIASTÆ, in antiquity, the judges of the court **HELIAEA**. They were so called, according to some authors, from a Greek word which signifies *to assemble in a great number*; and, according to others, from another word which signifies *the sun*, because they held their assemblies in an open place. They composed not only the most numerous, but likewise the most important of the Athenian tribunals; for their province was either to explain the obscure laws, or to give new vigour and authority to those which had been violated. The Thesmothetæ convoked the assembly of the Heliastæ, which sometimes amounted to 1000, sometimes to 1500, judges. Mr Blanchard is of opinion, that, to make this number, the Thesmothetæ sometimes summoned those of each tribe who had last quitted the public offices which they had exercised in another court.

However that may be, it appears that the assemblies of the Heliastæ were not frequent, as they would have interrupted the jurisdiction of the stated tribunals and the common course of affairs.

The Thesmothetæ paid to each member of this assembly, for his attendance, three oboli: which are equal to two Roman sesterces, or to half a drachma. Hence Aristophanes terms them *the brothers of the triobolus*. They were likewise condemned to pay a fine if they came too late; and if they did not present themselves till after the orators had begun to speak, they were not admitted. Their attendance was requited out of the public treasury, and their pay was called *misthos heliasticus*.

The assembly met, at first, according to Aristophanes, at the rising of the sun. If the judges were obliged to meet under cover on account of frost and snow, they had a fire; but there is not a passage in any ancient author which informs us of the place where these assemblies were held either in the rigorous or in the mild seasons. We only learn, that there was a double enclosure around the assembly, that it might not be disturbed. The first was a kind of arbour-work, from space to space, separated by doors, over which were painted in red the ten or twelve first letters of the Greek alphabet, which directed the entrance of the officers who composed the tribunal, each of them entering under the letter which distinguished his tribe. The beakles of the court, to whom they showed the wand which had been sent them by the Thesmothetæ as a summons to meet, examined its mark, to see if it was authentic, and then introduced them. The second enclosure, which was at the distance of 20 feet from the former, was a rope or cord; that the people who stood round the first enclosure, and were desirous to see what passed within the second, might not be prevented from gratifying their curiosity at a proper distance. Thus the attention of the judges was not interrupted by the concourse of the multitude, many of whom were heated by views of interest or of party.

To each of the members of the assembly were distributed two pieces of copper; one of which was perforated, not certainly that it might be distinguished from the other by feeling, for these assemblies met at the rising and were dissolved at the setting of the sun. Those pieces of copper had been substituted for little sea-shells, which were at first in use. The king was present at the assembly, at whose command it had been summoned.

Heliastæ. summoned. The Thesmothetæ read the names of those who were to compose it, and each man took his place as he was called. The Thesmothetæ were then sent for, whose function it was to observe prodigies and to superintend the sacrifices; and if they gave their sanction, the deliberations were begun. It is well known, that the officers called *Exegetæ* were often corrupted by those who were interested in the debates of the assembly; and that they excited such tumults as were raised by the Roman tribunes in the popular assemblies convoked by the consuls.

Of all the monuments which remain relating to the Heliastæ, the most curious is the oath which those judges took before the Thesmothetæ: Demosthenes hath preserved it in his oration against Timocrates, who having been bribed by those who had been intrusted with the effects taken on board a vessel of Naucratis, and refused to give an account of them, got a law passed, by which an enlargement was granted to prisoners for public debts on giving bail. Demosthenes on making his oration against that law, ordered the oath of the Heliastæ to be read aloud, as a perpetual auxiliary to his arguments, and happily calculated to interest the multitude and inflame their passions. This oath we shall quote, that our readers may know how respectable a tribunal that of the Heliastæ was, and the importance of their decisions.

“ I will judge according to the laws and decrees of the people of Athens, and of the senate of 500. I will never give my vote for the establishment of a tyrant, or of an oligarchy. Nor will I ever give my approbation to an opinion prejudicial to the liberty or to the union of the people of Athens. I will not second those persons who may propose a reduction of private debts, or a distribution of the lands or houses of the Athenians. I will not recal exiles, or endeavour to procure a pardon for those who shall be condemned to die. Nor will I force those to retire whom the laws and the suffrages of the people shall permit to remain in their country. I will not give my vote to any candidate for a public function who gives not an account of his conduct in the office which he has previously filled; nor will I presume to solicit any trust from the commonwealth without subjecting myself to this condition, which I mean as obligatory to the nine archons, to the chief of religious matters, to those who are balloted on the same day with the nine archons, to the herald, the ambassador, and the other officers of their court. I will not suffer the same man to hold the same office twice, or to hold two offices in the same year. I will not accept any present, either myself or by another, either directly or indirectly, as a member of the Heliastic assembly. I solemnly declare that I am 30 years old. I will be equally attentive and impartial to the accuser and the accused; I will give my sentence rigorously according to evidence. Thus I swear, by Jupiter, by Neptune, and by Ceres, to act. And if I violate any of my engagements, I imprecate from these deities ruin on myself and my family; and I request them to grant me every kind of prosperity, if I am faithful to my oath.”

The reader should peruse what follows this oath, to see with what eloquence Demosthenes avails himself of it, and how he applies its principles to the cause which he defends.

Here we have one of the motives of the meeting of this assembly. Aristotle informs us of another; which was by the public authority deputed to them, to elect a magistrate in the room of one dead. It is surprising that Pausanias, who enters so often into details, gives us no particular account of this assembly. All that he says of it is, that the most numerous of the Athenian assemblies was called *Helicè*.

We are told by Diogenes Laertius, in his life of Solon, that it was before one of these Heliastic assemblies that Pisistratus presented himself, covered with wounds and contusions (for thus he had treated himself and the mules which drew his car), to excite the indignation of the people against his pretended enemies, who, jealous, as he alleged, of the popularity he had acquired by asserting the rights of his poorer fellow-citizens, in opposition to the men in power, had attacked him while he was hunting, and had wounded him in that barbarous manner. His design succeeded: a guard was appointed him; by the assistance of which he acquired the sovereignty or tyranny of Athens, and kept it 33 years. The power of the assembly appeared remarkably on that occasion; for Solon, who was present, opposed it with all his efforts, and did not succeed.

As to the manner in which the judges gave their suffrages, there was a sort of vessel covered with an osier mat, in which were placed two urns, the one of copper, the other of wood. In the lid of these urns there was an oblong hole, which was large at the top, and grew narrower downwards, as we see in some old boxes of our churches. The suffrages which condemned the accused person were thrown into the wooden urn, which is termed *kyrios*. That of copper, named *akyros*, received those which absolved him.

Aristotle observes, that Solon, whose aim was to make his people happy, and who found an aristocracy established by the election of the nine archons (annual officers, whose power was almost absolute), tempered their sovereignty, by instituting the privilege of appealing from *them* to the people; who were to be assembled by lot to give their suffrage, after having taken the oath of the Heliastæ, in a place near the Panathenæum, where Hissus had in former days calmed a sedition of the people, and bound them to unanimity by an oath. It has likewise been remarked, that the god Apollo was not invoked in the oath of the Heliastæ, as in the oaths of the other judges. We have observed, that he who took the oath of the Heliastæ, engaged that he would not be corrupted by solicitation or money. Those who violated this part of their oath were condemned to pay a severe fine. The decemvirs at Rome made such corruption a capital crime. But Asconius remarks, that the punishment denounced against them was mitigated in later times; and that they were expelled the senate, or banished for a certain time, according to the degree of their guilt.

HELICOID PARABOLA, or the *Parabolic Spiral*, is a curve arising from the supposition that the common or Apollonian parabola is bent or twisted, till the axis comes into the circumference of a circle, the ordinates still retaining their places and perpendicular positions with respect to the circle, all these lines still remaining in the same plane.

Heliastæ
Helicoid
Parabola.

Helicon
Heliodorus.

HELICON, in *Ancient Geography*, the name of a mountain in the neighbourhood of Parnassus and Cytheron, sacred to Apollo and the muses, who are thence called *Heliconides*. It is situated in Livadia, and now called *Zagura* or *Zaguya*.—Helicon was one of the most fertile and woody mountains in Greece. On it the fruit of the *adrachnus*, a species of the *arbutus* or of the strawberry-tree, was uncommonly sweet; and the inhabitants affirmed, that the plants and roots were all friendly to man, and that even the serpents had their poison weakened by the innoxious qualities of their food. It approached Parnassus on the north, where it touched on Phocis; and resembled that mountain in loftiness, extent, and magnitude.—Here was the shady grove of the muses and their images; with statues of Apollo and Bacchus, of Linus and Orpheus, and the illustrious poets who had recited their verses to the harp. Among the tripods, in the second century, was that consecrated by Hesiod. On the left hand going to the grove was the fountain *Aganippe*; and about twenty stadia, or two miles and a half, higher up, the violet-coloured *Hippocrene*. Round the grove were houses. A festival was celebrated there by the Thespians with games called *Musea*. The valleys of Helicon are described by Wheler as green and flowery in the spring; and enlivened by pleasing cascades and streams, and by fountains and wells of clear water. The Bœotian cities in general, two or three excepted, were reduced to inconsiderable villages in the time of Strabo. The grove of the muses was plundered under the auspices of Constantine the Great. The Heliconian goddesses were afterwards consumed in a fire at Constantinople, to which city they had been removed.

HELICONIA, a genus of plants belonging to the pentandria class. See *BOTANY Index*.

HELICTERES, the *SCREW-TREE*; a genus of plants belonging to the gynandria class, and in the natural method ranking under the 37th order, *Columnifera*. See *BOTANY Index*.

HELIGOLAND, a group of small islands in the north sea, now subject to Great Britain. See *SUPPLEMENT*.

HELIOCARPUS, a genus of plants belonging to the dodecandria class, and in the natural method ranking under the 37th order, *Columnifera*. See *BOTANY Index*.

HELIOCENTRIC LATITUDE of a Planet, the inclination of a line drawn between the centre of the sun and the centre of a planet to the plane of the ecliptic.

HELIOCENTRIC Place of a Planet, the place of the ecliptic wherein the planet would appear to a spectator placed at the centre of the sun.

HELIOCOMETES, a phenomenon sometimes observed about sun-setting; being a large luminous tail or column of light proceeding from the body of the sun, and dragging after it, not unlike the tail of a comet; whence the name.

HELIODORUS of *PHOENICIA*, bishop of Trica in Thessaly, better known by the romance he composed in his youth entitled *Æthiopica*, and relating the amours of Theagenes and Chariclea. Some say he was deposed by a synod because he would not consent to the suppressing that romance. The fable has a moral tendency, and particularly inculcates the virtue of chastity.

As it was the first of this species of writing, he is styled *the Father of Romances*. He was also a good Latin poet. He lived in the 4th century.

Heliodorus.
Heliometer.

HELIOMETER, formed of ἥλιος, *sun*, and μέτρον, *I measure*, the name of an instrument called also *astrometer*, invented by M. Bouguer in 1747, for measuring with particular exactness the diameters of the stars, and especially those of the sun and moon.

This instrument is a kind of telescope, consisting of two object-glasses of equal focal distance, placed one of them by the side of the other, so that the same eye-glass serves for both. The tube of this instrument is of a conic form, larger at the upper end, which receives the two object-glasses, than at the lower, which is furnished with an eye-glass and micrometer. By the construction of this instrument two distinct images of an object are formed in the focus of the eye-glass, whose distance, depending on that of the two object-glasses from one another, may be measured with great accuracy: nor is it necessary that the whole disc of the sun or moon come within the field of view, since, if the images of only a small part of the disc be formed by each object-glass, the whole diameter may be easily computed by their position with respect to one another: for if the object be large, the images will approach, or perhaps lie even over one another, and the object-glasses being moveable, the two images may always be brought exactly to touch one another, and the diameter may be computed from the known distance of the centres of the two glasses. Besides, as this instrument has a common micrometer in the focus of the eye-glass, when the two images of the sun or moon are made in part to cover one another, that part which is common to both the images may be measured with great exactness, as being viewed upon a ground that is only one half less luminous than itself; whereas, in general, the heavenly bodies are viewed upon a dark ground, and on that account are imagined to be larger than they really are. By a small addition to this instrument, provided it be of a moderate length, M. Bouguer thought it very possible to measure angles of three or four degrees, which is of particular consequence in taking the distance of stars from the moon. With this instrument M. Bouguer, by repeated observation, found that the sun's vertical diameter, though somewhat diminished by the astronomical refraction, is longer than the horizontal diameter; and, in ascertaining this phenomenon, he also found, that the upper and lower edges of the sun's disc are not so equally defined as the other parts; on this account his image appears somewhat extended in the vertical direction. This is owing to the decomposition of light, which is known to consist of rays differently refrangible in their passage through our atmosphere. Thus the blue and violet rays, which proceed from the upper part of the disc at the same time with those of other colours, are somewhat more refracted than the others, and therefore seem to us to have proceeded from a higher point; whereas, on the contrary, the red rays proceeding from the lower edge of the disc, being less refracted than the others, seem to proceed from a lower point; so that the vertical diameter is extended, or appears longer, than the horizontal diameter.

Mr Servington Savery discovered a similar method of:

Heliometer
||
Helix.

of improving the micrometer, which was communicated to the Royal Society in 1753. See MICROMETER.

HELIOPHILA, a genus of plants belonging to the tetradynamia class of plants; and in the natural method ranking under the 39th order, *Siliquosa*. See BOTANY *Index*.

HELIOPHOBI, a name given to the white negroes or albinos, from their aversion to the light of the sun. See ALBINO.

HELIOPOLIS, in *Ancient Geography*, so called by Herodotus and Diodorus Siculus, by Moses *On*, and in Jeremiah *Bethsemes*; a city of Egypt, to the south-east of the Delta, and east of Memphis; of a very old standing, its origin terminating in fable. Here stood the temple of the sun, held in religious veneration. The city stood on an extraordinary mount, but in Strabo's time was desolate. It gave name to the *Nomos Heliopolites*.—There was another *Heliopolis* in Cœlo-syria, near the springs of the Orontes; so called from the worship of the sun, which was in great vogue over all Syria.

HELIOSCOPE, in *Optics*, a sort of telescope, peculiarly fitted for viewing the sun without hurting the eyes. See TELESCOPE.

As the sun may be viewed through coloured glasses without hurt to the eyes, if the object and eye-glasses of a telescope be made of coloured glass, as red or green, such a telescope will become an helioscope.

But Mr Huygens only used a plain glass, blacked at the flame of a candle on one side, and placed between the eye-glass and the eye; which answers the design of an helioscope very well.

HELIOSTATA, in *Optics*, an instrument invented by the late learned Dr S. Gravesande, who gave it this name from its fixing, as it were, the rays of the sun in an horizontal direction across the dark chamber all the while it is in use. See OPTICS *Index*.

HELIOTROPE (*heliotropium*), among the ancients, an instrument or machine for showing when the sun arrived at the tropics and the equinoctial line. This name was also used for a sun dial in general.

HELIOTROPE is also a precious stone, of a green colour, streaked with red veins. Pliny says it is thus called, because, when cast into a vessel of water, the sun's rays falling thereon seem to be of a blood-colour; and that, when out of the water, it gives a faint reflection of the figure of the sun; and is proper to observe eclipses of the sun as a helioscope. The heliotrope is also called *oriental jasper*, on account of its ruddy spots. It is found in the East Indies, as also in Ethiopia, Germany, Bohemia, &c. Some have ascribed to it the faculty of rendering people invisible, like Gyges's ring.

HELIOTROPIUM, **TURNSOLE**, a genus of plants belonging to the pentandria class, and in the natural method ranking under the 41st order, *Asperifolia*. See BOTANY *Index*.

HELISPHERICAL LINE, is the rhumb line in *Navigation*, being so termed, because on the globe it winds round the pole helically or spirally, coming still nearer and nearer to it.

HELIX, in *Geometry*, a spiral line. See SPIRAL.—The word is Greek, *ἑλιξ*, and literally signifies "a wreath or winding;" of *ἔλωρα*, *involvere*, "I environ."

In architecture, some authors make a difference be-

tween the helix and the spiral. A staircase, according to Daviler, is in a helix, or is helical, when the stairs or steps wind round a cylindrical newel; whereas the spiral winds round a cone, and is continually approaching nearer and nearer its axis.

HELIX is also applied, in *Architecture*, to the caulicles or little volutes under the flowers of the Corinthian capital; called also *urilla*.

HELIX, in *Anatomy*, is the whole circuit or extent of the auricle or border of the ear outwards. In opposition to which, the inner protuberance surrounded thereby, and answering thereto, is called *anthelex*. See ANATOMY, N^o 141.

HELIX, the *Snail*, a genus of shell-fish belonging to the order of vermes testacea. See CONCHOLOGY *Index*.

HELL, the place of divine punishment after death.

As all religions have supposed a future state of existence after this life, so all have their hell or place of torment in which the wicked are supposed to be punished. The hell of the ancient heathens was divided into two mansions, the one called *Elysium*, on the right hand, pleasant and delightful, appointed for the souls of good men; the other called *Tartara*, on the left, a region of misery and torment appointed for the wicked. The latter only was hell, in the present limited sense of the word. See ELYSIUM.

The philosophers were of opinion, that the infernal regions were at an equal distance from all the parts of the earth; nevertheless it was the opinion of some, that there were certain passages which led thither, as the river Lethe, near the Syrtis, and the Acherusian cave in Epirus. At Hermoine it was thought, that there was a very short way to hell; for which reason the people of that country never put the fare into the mouths of the dead to pay their passage.

The Jews placed hell in the centre of the earth, and believed it to be situated under waters and mountains. According to them, there are three passages leading to it; the first is in the wilderness, and by that Korah, Dathan, and Abiram, descended into hell; the second is in the sea, because Jonah, who was thrown into the sea, cried to God out of the belly of hell; the third is in Jerusalem, because it is said the fire of the Lord is in Zion, and his furnace is in Jerusalem. They likewise acknowledged seven degrees of pain in hell, because they find this place called by seven different names in Scripture. Though they believed that infidels, and persons eminently wicked, will continue for ever in hell; yet they maintained, that every Jew who is not infected with some heresy, and has not acted contrary to the points mentioned by the rabbins, will not be punished therein for any other crimes above a year at most.

The Mahometans believe the eternity of rewards and punishments in another life. In the Koran it is said, that hell has seven gates, the first for the Mussulmans, the second for the Christians, the third for the Jews, the fourth for the Sabians, the fifth for the Magians, the sixth for the Pagans, and the seventh for the hypocrites of all religions.

Among Christians, there are two controverted questions in regard to hell; the one concerns locality, the other the duration of its torments. 1. The locality of hell, and the reality of its fire, began first to be controverted by Origin. That father, interpreting the

Helix,
Hell.

Scripture

Hell
Helleborus

Scripture account metaphorically, makes hell to consist not in external punishments, but in a consciousness or sense of guilt, and a remembrance of past pleasures. Among the moderns, Mr Whiston advanced a new hypothesis. According to him, the comets are so many hells appointed in their orbits alternately to carry the damned into the confines of the sun, there to be scorched by its violent heat, and then to return with them beyond the orb of Saturn, there to starve them in those cold and dismal regions. Another modern author, not satisfied with any hypothesis hitherto advanced, assigns the sun to be the local hell. 2. As to the second question, viz. the duration of hell torments, we have Origen again at the head of those who deny that they are eternal; it being that father's opinion, that not only men but devils, after a due course of punishment suitable to their respective crimes, shall be pardoned and restored to heaven. The chief principle upon which Origen built his opinion, was the nature of punishment, which he took to be emendatory, applied only as physic for the recovery of the patient's health. The chief objection to the eternity of hell torments among modern writers, is the disproportion between temporary crimes and eternal punishments. Those who maintain the affirmative, ground their opinions on Scripture accounts, which represent the pains of hell under the figure of a worm which never dies, and a fire which is not quenched; as also upon the words, "These shall go away into everlasting punishment, but the righteous into life eternal."

HELANICUS of Mitylene, a celebrated Greek historian, born before Herodotus, flourished about 480 B. C. He wrote a history of the ancient kings and founders of cities, but which bath not come down to us.

HELLAS, in *Ancient Geography*, an appellation comprising, according to the more ancient Greeks and Romans, Achaia and Peloponnesus, but afterwards restrained to Achaia. It was bounded on the west by the river Achelous, on the north by Mounts Othrys and Oeta, on the east by the Egean sea, and on the south by the Saronic and Corinthian bays, and by the isthmus which joins it to Peloponnesus. It was called *Hellas*, from Hellen the son of Deucalion; or from *Hellas*, a district of Thessaly; whence *Hellenes*, the gentilitious name, denoting Greek. Now called *Livadia*.

HELLE, in fabulous history, a daughter of Athamas king of Thebes by Nephele. She fled from her father's house with her brother Phryxus, to avoid the cruel oppression of her mother-in-law Ino. According to some accounts she was carried through the air on a golden ram which her mother had received from Neptune, and in her passage she became giddy, and fell from her seat into that part of the sea which from her received the name of *Hellespont*. Others say that she was carried on a cloud, or rather upon a ship, from which she fell into the sea and was drowned. Phryxus, after he had given his sister a burial on the neighbouring coasts, pursued his journey, and arrived in Colchis.

HELLEBORE. See HELLEBORUS.

White HELLEBORE. See VERATRUM.

HELLEBORUS, HELLEBORE, a genus of plants belonging to the pentandria class, and in the natural

method ranking under the 26th order, *Multisiliquæ*. Helleborus See BOTANY Index.

HELLEN, the son of Deucalion, is said to have given the name of Hellenists to the people before called *Greeks*, 1521 B. C. See GREECE.

HELLENISM, in matters of language, a phrase in the idiom, genius, or construction of the Greek tongue.

This word is only used when speaking of the authors who, writing in a different language, express themselves in a phraseology peculiar to the Greek.

HELLENISTIC LANGUAGE, that used by the Grecian Jews who lived in Egypt and other parts where the Greek tongue prevailed. In this language it is said the Septuagint was written, and also the books of the New Testament; and that it was thus denominated to show that it was Greek filled with Hebraisms and Syriacisms.

HELLENISTS (*Hellenistæ*), a term occurring in the Greek text of the New Testament, and which in the English version is rendered Grecians.

The critics are divided as to the signification of the word, Oecumenius, in his Scholia on Acts vi. 1. observes, that it is not to be understood as signifying those of the religion of the Greeks, but those who spoke Greek, *τοις ἰσραηλῶσι φησὶ γράμματα*. The authors of the Vulgate version, indeed, render it like ours, *Græci*; but Messieurs Du Port Royal more accurately, *Juifs Grecs*, Greek or Grecian Jews; it being the Jews who spoke Greek that are here treated of, and who are hereby distinguished from the Jews called *Hebrews*, that is, who spoke the Hebrew tongue of that time.

The Hellenists, or Grecian Jews, were those who lived in Egypt and other parts where the Greek tongue prevailed. It is to them we owe the Greek version of the Old Testament, commonly called the *Septuagint*, or that of the Seventy.

Salmasius and Vossius are of a different sentiment with regard to the Hellenists. The latter will only have them to be those who adhered to the Grecian interests.

Scaliger is represented, in the Scaligerana, as asserting the Hellenists to be the Jews who lived in Greece and other places, and who read the Greek Bible in their synagogue, and used the Greek language *in sacris*: and thus they were opposed to the Hebrew Jews, who performed their public worship in the Hebrew tongue; and in this sense St Paul speaks of himself as a Hebrew of the Hebrews, Phil. iii. 5. i. e. a Hebrew both by nation and language. The Hellenists are thus properly distinguished from the *Hellenes* or Greeks, mentioned John xiii. 20. who were Greeks by birth and nation, and yet proselytes to the Jewish religion.

HELLENODICÆ, ἑλληνοδικαί, in antiquity, the directors of the Olympian games. At first there was only one, afterwards the number increased to two and to three, and at length to nine. They assembled in a place called ἑλληνοδικαίον, in the Eleian forum, where they were obliged to reside ten months before the celebration of the games, to take care that such as offered themselves to contend, performed their προγυμνασια, or preparatory exercises, and to be instructed in all the laws of games by certain men called νομοφύλακες, i. e. "keepers of the laws." And the better to prevent all unjust practices, they were farther obliged to take an

Hellenodica

Helleno-
dicae
||
Helm.

oath, that they would act impartially, would take no bribes, nor discover the reason for which they disliked or approved of any of the contenders. At the solemnity they sat naked, having before them the victorial crown till the exercises were finished, and then it was presented to whomsoever they adjudged it. Nevertheless, there lay an appeal from the hellenodicae to the Olympian senate.

HELLESPONT, a narrow strait between Asia and Europe, near the Propontis, which received its name from HELLE who was drowned there in her voyage to Colchis. It is celebrated for the love and death of Leander, and for the bridge of boats which Xerxes built over it when he invaded Greece. The folly of this great prince is well known in beating and fettering the waves of the sea, whose impetuosity fettered his ships, and rendered all his labours ineffectual. It is now called the *Dardanelles*. It is about 33 miles long, and in the broadest parts the Asiatic coast is about one mile and a half distant from the European, and only half a mile in the narrowest, according to modern investigation, and the cocks are heard crowing from the opposite shores.

HELLEN'S, ST., a town of the isle of Wight, in East-Medina, has a bay which runs a considerable way within land, and in a war with France is often the station and place of rendezvous for the royal navy. At the mouth of the bay is that cluster of rocks called the *Mizen*. It had an old church situated at the extremity of the coast, which was endangered to be washed away, as was a great part of the church-yard, which occasioned a new church to be built in 1719. The priory to which the old church belonged is now converted into a gentleman's seat; is in a remarkably pleasant situation, and commands a fine prospect of Portsmouth and the road at Spithead. St Hellen's appears to have been of more consideration in former times than at present.

HELM, a long and flat piece of timber, or an assemblage of several pieces, suspended along the hind-part of a ship's stern-post, where it turns upon hinges to the right or left, serving to direct the course of the vessel, as the tail of a fish guides the body.

The helm is usually composed of three parts, viz. the rudder, the tiller, and the wheel, except in small vessels, where the wheel is unnecessary.

As to the form of the rudder, it becomes gradually broader in proportion to its distance from the top, or to its depth under the water. The back, or inner part of it, which joins to the stern post, is diminished into the form of a wedge throughout its whole length, so as that the rudder may be more easily turned from one side to the other, where it makes an obtuse angle with the keel. It is supported upon hinges; of which those that are bolted round the stern-post to the after extremity of the ship, are called *googings*, and are furnished with a large hole on the after-part of the stern-post. The other parts of the hinges, which are bolted to the back of the rudder, are called *pinbles*, being strong cylindrical pins, which enter into the *googings*, and rest upon them. The length and thickness of the rudder is nearly equal to that of the stern-post.

The rudder is turned upon its hinges by means of a long bar of timber, called the *tiller*, which is fixed horizontally in its upper end within the vessel. The

movements of the tiller to the right and left, accordingly direct the efforts of the rudder to the government of the ship's course as she advances; which, in the sea-language, is called *steering*. The operations of the tiller are guided and assisted by a sort of tackle, communicating with the ship's side, called the *tiller-rope*, which is usually composed of untarred rope-yarns for the purpose of traversing more readily through the blocks or pulleys.

In order to facilitate the management of the helm, the tiller-rope, in all large vessels, is wound about a wheel, which acts upon it with the powers of a crane or windlass. The rope employed in this service being conveyed from the fore-end of the tiller *t*, to a single block *i*, on each side of the ship*, is farther commu-
* See Deck, Plate CLXIX.
nicated to the wheel, by means of two blocks suspended near the mizen-mast, and two holes immediately above, leading up to the wheel, which is fixed upon an axis on the quarter-deck, almost perpendicularly over the fore-end of the tiller. Five turns of the tiller-rope are usually wound about the barrel of the wheel; and, when the helm is amidship, the middle turn is nailed to the top of the barrel, with a mark by which the helmsman readily discovers the situation of the helm, as the wheel turns it from the starboard to the larboard side. The spokes of the wheel generally reach about eight inches beyond the rim or circumference, serving as handles to the person who steers the vessel. As the effect of a lever increases in proportion to the length of its arm, it is evident that the power of the helmsman to turn the wheel will be increased according to the length of the spokes beyond the circumference of the barrel.

When the helm, instead of lying in a right line with the keel, is turned to one side or the other, as in BD (fig. 1.), it receives an immediate shock from the water, which glides along the ship's bottom in running *ast* from A to B; and this fluid pushes it towards the opposite side, whilst it is retained in this position: so that the stern, to which the rudder is confined, receives the same impression, and accordingly turns from B to *b* about some point *c*, whilst the head of the ship passes from A to *a*. It must be observed, that the current of water falls upon the rudder obliquely, and only strikes it with that part of its motion which acts according to the sine of incidence, pushing it in the direction of NP, with a force which not only depends on the velocity of the ship's course, by which this current of water is produced, but also upon the extent of the sine of incidence. This force is by consequence composed of the square of the velocity with which the ship advances, and the square of the sine of incidence, which will necessarily be greater or smaller according to circumstances; so that if the vessel runs three or four times more swiftly, the absolute shock of the water upon the rudder will be nine or 16 times stronger under the same incidence: and, if the incidence is increased, it will yet be augmented in a greater proportion, because the square of the sine of incidence is more enlarged. This impression, or, what is the same thing, the power of the helm, is always very feeble, when compared with the weight of the vessel; but as it operates with the force of a long lever, its efforts to turn the ship are extremely advantageous. For the helm being applied to a great distance from the

Helm.

See Deck, Plate CLXIX.

Plate CCL.

Helm.

the centre of gravity G , or from the point about which the vessel turns horizontally, if the direction PN of the impression of the water upon the rudder be prolonged, it is evident that it will pass perpendicularly to R , widely distant from the centre of gravity G : thus the absolute effort of the water is very powerful. It is not therefore surprising, that this machine impresses the ship with a considerable circular movement, by pushing the stern from B to b , and the head from A to a ; and even much farther whilst she sails with rapidity, because the effect of the helm always keeps pace with the velocity with which the vessel advances.

Amoungst the several angles that the rudder makes with the keel, there is always one position more favourable than any of the others, as it more readily produces the desired effect of turning the ship, in order to change her course. To ascertain this, it must be considered, that if the obliquity of the rudder with the keel is greater than the obtuse angle ABD , so as to diminish that angle, the action of the water upon the rudder will increase, and at the same time oppose the course of the ship in a greater degree; because the angle of incidence will be more open, so as to present a greater surface to the shock of the water, by opposing its passage more perpendicularly. But at that time the direction NP of the effort of the helm upon the ship will pass with a smaller distance from the centre of gravity G towards R , and less approach the perpendicular NL , according to which it is absolutely necessary that the power applied should act with a greater effect to turn the vessel. Thus it is evident, that if the obtuse angle ABD is too much inclosed, the greatest impulse of the water will not counterbalance the loss sustained by the distance of the direction NP from NL , or by the great obliquity which is given to the same direction NP of the absolute effort of the helm with the keel AB . If, on the contrary, the angle ABD is too much opened, the direction NP of the force of the action of the helm will become more advantageous to turn the vessel, because it will approach nearer the perpendicular NL ; so that the line prolonged from NP will increase the line GR , by removing R to a greater distance from the centre of gravity G : but then the helm will receive the impression of the water too obliquely, for the angle of incidence will be more acute; so that it will only present a small portion of its breadth to the shock of the water, and by consequence will only receive a feeble effort. By this principle it is easy to conceive, that the greatest distance GR from the centre of gravity G , is not sufficient to repair the diminution of force occasioned by the too great obliquity of the shock of the water. Hence we may conclude, that when the water either strikes the helm too directly, or too obliquely, it loses a great deal of the effect it ought to produce. Between the two extremes there is therefore a mean position, which is the most favourable to its operations.

The diagonal NP of the rectangle IL represents the absolute direction of the effort of the water upon the helm. NI expresses the portion of this effort which is opposed to the ship's head-way, or which pushes her astern, in a direction parallel to the keel. It is easily perceived, that this part NI of the whole power of the helm contributes but little to turn the vessel; for, if IN

VOL. X. Part I.

is prolonged, it appears that its direction approaches to a very small distance GV from the centre of gravity G ; and that the arm of the lever $BN=GV$, to which the force is applied, is not in the whole more than equal to half the breadth of the rudder: but the relative force NL , which acts perpendicular to the keel, is extremely different. If the first NI is almost useless, and even pernicious, by retarding the velocity; the second NL is capable of a very great effect, because it operates at a considerable distance from the centre of gravity G of the ship, and acts upon the arm of a lever GE , which is very long. Thus it appears, that between the effects NL and NI , which result from the absolute effort NP , there is one which always opposes the ship's course, and contributes little to her motion of turning: whilst the other produces only this movement of rotation, without operating to retard her velocity.

Geometricians have determined the most advantageous angle made by the helm with the line prolonged from the keel, and fixed it at $54^{\circ} 44'$, presuming that the ship is as narrow at her floating-line, or at the line described by the surface of the water round her bottom, as at the keel. But as this supposition is absolutely false, in as much as all vessels augment their breadth from the keel upward to the extreme breadth, where the floating-line or the highest water-line is terminated; it follows, that this angle is too large by a certain number of degrees. For the rudder is impressed by the water, at the height of the floating line, more directly than at the keel, because the fluid exactly follows the horizontal outlines of the bottom; so that a particular position of the helm might be supposed necessary for each different incidence which it encounters from the keel upwards. But as a middle position may be taken between all these points, it will be sufficient to consider the angle formed by the sides of the ship, and her axis, or the middle line of her length, at the surface of the water, in order to determine afterwards the mean point, and the mean angle of incidence.

It is evident that the angle $54^{\circ} 44'$ is too open, and very unfavourable to the ship's head-way, because the water acts upon the rudder there with too great a sine of incidence, as being equal to that of the angle which it makes with the line prolonged from the keel below: but above, the shock of the water is almost perpendicular to the rudder, because of the breadth of the bottom, as we have already remarked. If then the rudder is only opposed to the fluid, by making an angle of 45° with the line prolonged from the keel, the impression, by becoming weaker, will be less opposed to the ship's head-way, and the direction NP of the absolute effort of the water upon the helm drawing nearer to the lateral perpendicular, will be placed more advantageously, for the reasons above mentioned. On the other hand, experience daily testifies, that a ship steers well when the rudder makes the angle DBE equal to 35° only.

It has been already remarked, that the effect of moving the wheel to govern the helm increases in proportion to the length of the spokes; and so great is the power of the wheel, that if the helmsman employs a force upon its spokes equivalent to 30 pounds, it will produce an effect of 90 or 120 pounds upon the

T t

Helm.

He'm.

tiller. On the contrary, the action of the water is collected into the middle of the breadth of the rudder, which is very narrow in comparison with the length of the tiller; so the effort of the water is very little removed from the fulcrum B upon which it turns; whereas the tiller forms the arm of a lever 10 or 15 times longer, which also increases the power of the helmsman in the same proportion that the tiller bears to the lever upon which the impulse of the water is directed. This force then is by consequence 10 or 15 times stronger; and the effort of 30 pounds, which at first gave the helmsman a power equal to 90 or 120 pounds, becomes accumulated to one of 900 or 1800 pounds upon the rudder. This advantage then arises from the shortness of the lever upon which the action of the water is impressed, and the great comparative length of the tiller, or lever, by which the rudder is governed; together with the additional power of the wheel that directs the movements of the tiller, and still farther accumulates the power of the helmsman over it. Such a demonstration ought to remove the surprize with which the prodigious effect of the helm is sometimes considered, from an inattention to its mechanism; for we need only to observe the pressure of the water, which acts at a great distance from the centre of gravity G, about which the ship is supposed to turn, and we shall easily perceive the difference there is between the effort of the water against the helmsman, and the effect of the same impulse against the vessel. With regard to the person who steers, the water acts only with the arm of a very short lever NB, of which B is the fulcrum: on the contrary, with regard to the ship, the force of the water is impressed in the direction NP, which passes to a great distance from G, and acts upon a very long lever EG, which renders the action of the rudder extremely powerful in turning the vessel; so that, in a large ship, the rudder receives a shock from the water of 2700 or 2800 pounds, which is frequently the case when she sails at the rate of three or four leagues by the hour; and this force being applied in E, perhaps 100 or 110 feet distant from the centre of gravity G, will operate upon the ship, to turn her about, with 270,000 or 308,000 pounds; whilst, in the latter case, the helmsman acts with an effort which exceeds not 30 pounds upon the spokes of the wheel.

After what has been said of the helm, it is easy to judge, that the more a ship increases her velocity with regard to the sea, the more powerful will be the effect of the rudder; because it acts against the water with a force, which increases as the square of the swiftness of the fluid, whether the ship advances or retreats; or, in other words, whether she has head-way or stern-way: with this distinction, that in these two circumstances the effects will be contrary. For if the vessel retreats, or moves astern, the helm will be impressed from I to N; and instead of being pushed, according to NP, it will receive the effort of the water from N towards R; so that the stern will be transported to the same movement, and the head turned in a contrary direction.

Helm
|
Helminthology.

When the helm, operates by itself, the centre of rotation of the ship, and her movement, are determined by estimating the force of this machine; that is to say, by multiplying the surface of the rudder by the square of the ship's velocity.

There are several terms in the sea-language relating to the helm; as, *Bear up the helm*; that is, Let the ship go more large before the wind. *Helm a mid-ship*, or *right the helm*: that is, Keep it even with the middle of the ship. *Port the helm*, Put it over the left side of the ship. *Starboard the helm*, Put it on the right side of the ship.

HELMET, an ancient defensive armour worn by horsemen both in war and in tournaments. It covered both the head and face, only leaving an aperture in the front secured by bars, which was called the *visor*.

In achievements, it is placed above the escutcheon for the principal ornament, and is the true mark of chivalry and nobility. Helmets vary according to the different degrees of those who bear them. They are also used as a bearing in coats of arms. See HERALDRY.

HELMINTHOLITHUS, in *Natural History*, a name given by Linnæus to petrified bodies resembling worms.

Of these he reckons four genera. 1. Petrified lithophyta. 2. Petrified shells. 3. Petrified zoophytes. 4. Petrified reptiles.

HELMINTHOLOGY.

INTRODUCTION.

¹ **Definition.** UNDER this head we propose to give the natural history of those animals which Linnæus has arranged under the class of VERMES, forming the last class of the animal kingdom. The title which we have adopted for this article is derived from the Greek *ὄμιον*, an earth-worm, and *λογος*, a discourse.

In this article we are to consider, not only those animals which are commonly known by the name of worms, but all those which have the same general character of being *slow in motion, of a soft substance, extremely insensious of life, capable of reproducing such*

parts of their body as may have been taken away or destroyed, and inhabiting moist places.

Linnæus has divided the class into five orders. ² **Division.**
³ 1. *Intestina*, consisting of animals which are very simple in their structure, and most of which live within other animals; such as the worms which infest the intestines of man, quadrupeds, &c., though many of them are found in moist clay, and other damp situations. ^{Intestina}

⁴ 2. *Mollusca*, containing such animals as have naked bodies, or are not furnished with shells, but are provided with *tentacula* or arms, being mostly inhabitants of the sea. ^{Mollusca}

³ 3. *Testacea*,

Introduc-
tion.

Introduc-
tion.

5
Testacea.

10
Advan-
tages at-
tending

6
Zoophyta.

the study.

7
Infusoria.

8
Helmintho-
logy the
most imper-
fect part of
natural
history.

9
Difficulty
of the study.

3. *Testacea*, differing from the former in little more than their being furnished with calcareous, shelly coverings, which they carry about with them, constituting the great variety of shell-fish, snails, &c.

4. *Zoophyta*, containing such creatures as seem to bear a resemblance both to plants and animals; being fixed to one place by a sort of root, and shooting up into stems like plants, but possessing besides the powers of animation, and partially of locomotion.

5. *Infusoria*, comprising those animated beings generally called *animalcules*, that are found in most watery liquors; especially in the infusions of vegetable substances.

Of these five orders, only four fall to be particularly considered in this article, the *testacea* having been already fully treated of under CONCHOLOGY.

The animals which we are about to describe are generally considered as the lowest in the scale of animated being. The simplicity of their form, the homility of their station, and the low degree of sense and motion which most of them enjoy, render them an object of little attention to mankind in general, excepting in so far as they contribute to the supply of their wants, or render themselves formidable, by the pain and distress which they occasion to those bodies which nature seems to have destined for their habitation. But to the eye of the naturalist, every part of nature becomes interesting, and this humble class of beings has, in later times, attracted a considerable share of attention.

Still, however, this part of natural history is much more imperfect than any other, and so it will probably long remain, partly from the difficulty of prosecuting our enquiries, and partly from the little interest which a superficial observation of many of these animals is calculated to excite. It will not be thought extraordinary that they are less known than other animals, when we consider, that the examination of them does not offer so many allurements as that of insects, birds, and the more showy part of the animal creation, and is besides impeded by much greater difficulties. Many of them cannot be obtained without diving to the bottom of the sea, or braving pain and danger in the pursuit. The *furia infernalis* attacks the searcher in the marshy plains of Bothnia, and the *sepia octopus* stretches forth his gigantic arms, to entangle and drag him to his watery den. Hence the opportunities of examination are often rare; and from the changes which many of the species undergo, we cannot always be certain whether one which we may meet with hereafter be a new species, or one which we have seen before.

This circumstance has occasioned several varieties to be described as distinct species, and the same species to be repeated under different names, to the great confusion of the naturalist. Again; the consistence of their bodies is, in many cases, so soft, that they can scarcely be preserved in our cabinets, and thus the observer is de-

prived of one of the chief sources of information and reference, which, in other departments of the science, is so well calculated to assist his studies.

The study of helminthology, however, holds out many inducements to the admirer of nature's works, as it affords an ample field for the gratification of his curiosity, and may even be rendered subservient to the advancement of more solid and useful knowledge.

If we consider the number of animals, which naturalists have included under the general name of *worms*; if we observe the simplicity of form in some of them, and the complicated structure of others; in fine, if we reflect on the various modes in which they are propagated, and on the surprising faculty, which many of them possess, of spontaneous reproduction: the imagination will be astonished with their number and variety, and confounded by their wonderful properties. The waters are peopled with myriads of animated beings, which, though invisible to our unassisted eyes, are endowed with organs as perfect as the largest animals, since, like these, they reproduce their like, and hold in the scale of nature a rank as little equivocal, though less obvious and obtrusive. The elegance of form and beauty of colour, which some of the *mollusca* and *zoophyta* possess, must render them an object of admiration to the most indifferent observer.

The physiologist will derive considerable assistance in explaining some obscure functions of the animal economy, from a comparative view of them in this humble class of beings; while the physician, by acquiring a knowledge of the habitudes of such of them as infect the bodies of man, will be the better able to ascertain their presence, expel them from their habitation, or counteract their effects. The geologist, though he cannot admit the hypothesis of Buffon, that all the limestone of this earth has been formed from the reliicks of corals and shell-fish, will yet here trace the origin of many of the secondary strata, and from the wonderfully rapid production of coral reefs, which we shall notice towards the conclusion of this article, will find little difficulty in accounting for the evolution of new land from the bosom of the deep.

We shall divide the sequel of this article into two chapters, the first of which will contain a general view of the classification of the genera, and in the second will be given the classification and natural history of the species. The latter will be subdivided into four sections, corresponding to the four orders of *intestina*, *mollusca*, *zoophyta*, and *infusoria*. As we are able to devote but a small portion of our work to this subject, we shall confine any particular description to those species which are of most importance; and to relieve the tediousness of systematic arrangement, we shall mention every thing worth notice under the genus or species then under consideration.

CHAP. I. CLASSIFICATION OF THE GENERA.

LINNÆUS, whose extensive genius has displayed itself so eminently in almost every department of natural history, has, perhaps, failed more in this part of the science than in any other. In the earlier editions of the *Systema Naturæ*, the individuals described are comparatively few, and the characters of many of them are imperfect or erroneous. These imperfections must be attributed to the small progress which helminthology had made in the beginning of last century, as the discoveries of succeeding naturalists have contributed not only to increase the number of genera and species far beyond what were known at that time, but also to improve their distinguishing characters.

M. Bruigiere, to whom this part of the *Encyclopædie Methodique* was allotted, made several alterations in the arrangement of Linnæus, whose general classification he has followed in the tabular view of the subject prefixed to the plates of helminthology. M. Bruigiere's work is entitled to much praise, and it is to be regretted that he did not live to complete his undertaking.

11
Classification of Cuvier.

The arrangement of these animals given by Cuvier, is in great esteem on the continent, and will probably, when fully completed by future discoveries of that celebrated naturalist, supersede the Linnæan classification. Cuvier has given a tabular view of his classification, at the end of the first volume of his *Comparative Anatomy*, and a more detailed account in his *Tableau Elementaire d'Histoire Naturelle*. He arranges the *vermes* of Linnæus under three heads; MOLLUSCA, WORMS, and ZOOPHYTES. The following is a translation of the tables.

I. MOLLUSCA.

A. Head furnished with Tentacula that serve for Feet.

Family 1. CEPHALOPODA.

a. Naked.

SEPIA, comprehending the *sepia*, *loligo*, and *octopus*.

b. Testaceous.

ARGONAUTA.

NAUTILUS.

B. Head free, and crawling on the belly.

Fam. 2. GASTEROPODA.

a. Having no shell, or having the shell concealed by the flesh.

CLIO.

SCYLLE.

DORIS.

TRITONIA.

ÆOLIA.

PHYLLIDIA.

THETIS.

LIMAX.

TESTACELLA.

SEGARETUS.

APLYSIA.

b. With an apparent Shell.

a. In several pieces. Multivalves.

CHITON.

β. Conical. Conivalves.

PATELLA, comprehending *fissurella*, *patella*, *crepidula*, and *calyptrea*.

γ. Spiral. Spirivalves.

1. With the Aperture entire.

HALIOTIS.

NERITA, comprehending *nerita* and *narica*.

TURBO, comprehending *turbo*, *cyclostoma*, and *turrella*.

VERMITUS.

TROCHUS, comprehending *pyramidalis*, *trochus*, *monodonta*, and *solarium*.

BULLA.

HELIX, comprehending *planorbis*, *helix ampullaris*, *mellania*, *bulimus*, *achatina*.

2. With the Aperture sloped towards the bottom.

VOLUTA, comprehending *voluta*, *mitra*, *columbella*, *marginella*, *ancilla*, and *oliva*.

OVULA.

CYPRÆA.

CONUS.

TEREBELLUM.

3. With the Aperture ending in a Canal.

MUREX, comprehending *cerithium*, *pleurotoma*, *fusus*, *fasciolaria*, *pyrula*, *murex*, and *turbinella*.

STROMBUS, comprehending *strombus*, *ptero-cera*, and *rostellaria*.

BUCCINUM, comprehending *cassidea*, *harpa*, *buccinum*, *terebræ*, *purpura*, and *nassa*.

C. Having no distinct Head.

Fam. 3. ACEPHALA.

a. Having no Shells, but furnished with a membranous leathery cloak.

ASCIDIA.

SALPA.

PTEROTRACHEA.

THALIA.

b. With a cloak, and furnished with Shells.

a. Open anteriorly, having no reticulated Feelers, nor ciliated arms.

1. Inoquivalves.

OSTREA.

LAZARUS.

SPONDYLUS.

PLACUNA.

ANOMIA.

PECTEN.

Genera. 2. *Equivalves, having a foot fitted for crawling, without tubes.*

ANODONTITES.
UVA.

3. *Equivalves with a Foot constructed for spinning, without tubes.*

LIMA.
PERNA.
AVICULA, comprehending *avicula* and *malleus*.
MYTILUS, comprehending *mytilus* and *modiolus*.
PINNA.

4. *Having tubes in the cloak, serving for an anus, and for respiration, and a Foot frequently fitted for spinning.*

TELLINA.
CARDIUM, comprehending *cardium* and *isocardia*.
MACTRA, comprehending *mactra*, *lutraria*, and *crasatella*.
VENUS, comprehending *venus*, *meretrix*, *cyclas*, *paphia*, and *capsa*.
DONAX.
CHAMA, comprehending *cardita*, *tridacna*, and *hippopus*.

ARCA, comprehending *arca*, *pertunculus*, and *nucula*.

5. *Open at one extremity, which is perforated by the foot, and prolonged towards the other end into a double tube.*

SOLENIUM, comprehending *solen* and *sanguilonaria*.
MYA, comprehending *mya*, *glycimeris*, and *cyrtodaria*.

PHOLAS, comprehending *pholas* and *gizania*.
TEREDO, comprehending *teredo* and *fistulana*.

6. *Open before, having neither foot nor tubes, but two ciliated arms rolled into a spiral form.*

TEREBRATULA, comprehending *terebratula*, *calceola*, and *hyalæa*.
LINGULA.
ORBICULA.

7. *Open before, having neither feet nor tubes, except one proceeding from the body, and furnished with feelers that are horny, articulated, and arranged in pairs.*

ANATIFA.
BALANUS.

II. WORMS.

A. *Having external organs fitted for respiration.*

a. *Furnished with bristles on the side of the body.*

APHRODITA.
TEREBELLA.
NEREIS.
SERPULA.
PENICILLUS.
SILICULARIA.
AMPHITRITE.
DENTALIUM.

B. *Having no external organs of respiration.*

a. *With bristles on the sides of the body.*

NAIS.
LUMBRICUS.
THALOSOEMA.

b. *Having no bristles on the sides of the body.*

HIRUDO.
FASCIOLA.
PLANARIA.
GORDIUS.

Cuvier is uncertain whether he should place the following genera in the same class with the preceding, or arrange them under a new class, next to the zoophytes.

Family 1.

TENIA.
HYDATIGENA.
LIGULA.
LINGUATULA.

Family 2.

ASCARIS, and the other *intestinalia*.

III. ZOOPHYTES.

A. *Not attached.*

a. *Having a calcareous or leathery covering, and the intestines floating in the internal cavity.* Echinodermata.

ECHINUS, comprehending *echinus*, *brissus*, and *spatagus*.

ASTERIAS.
HOLOTHURIA.
SIPUNCULUS.

b. *Having a fleshy or gelatinous covering, and the intestines adhering within the body.* *Urtica marina*.

ACTINIA, comprehending *actinia* and *saanthis*.
MEDUSA, comprehending *medusa*, *berozé*, and *rhizostoma*.

c. *Very small, and found swimming in liquors.* Infusoria.

ROTIFER.
BRACHIONUS.
TRICHOCERCUS.
TRICHODA.
LEUCOPHRUS, and the rest of the *aminacula infusoria*.

c. *Having a gelatinous body, and propagating by shoots or branches.* Polypa.

HYDRA.
VORTICELLA.

B. *Attached to a solid trunk.*

a. *Having the medullary substance traversing a horny axis,*

Genera. *axis, and terminating the branches, in the form of Polypes. Zoophyta properly so called.*

FLOSCULARIA.
TUBULARIA.
CAPSULARIA.
SERTULARIA.

b. Having the polypes not collected to a medullary axis, but each inclosed in a horny or calcareous cell. Es-cara.

CELLULARIA.
FLUSTRA.
CORALLINA.

c. Having the solid axis covered with sensible flesh, from the hollows of which the polypes proceed. Ce-ratophyta.

ANTIPATHES.
GORGONIA.
CORALLIUM.
ISIS.
PENNATULA.
VERTICILIUM.
UMBELLULA.

d. Having cavities in the stony basis, for receptacles to the Polypes. Lithophyta.

MADREPORA.
MILLEPORA.

e. Having a spongy friable or fibrous basis. Sponges.

ALCYONIUM.
SPONGIA.

Since the publication of these tables, M. Cuvier has made several alterations and additions to the class of MOLLUSCA, which are the subject of several excellent memoirs published in the *Annales de Museum National*; in particular he has formed a new order in this class, to which he gives the following characters. *Body free, swimming; head distinct; having no other member but fins.* In this order he arranges three genera, the old genus CLIO, and two new ones, which he calls HYALE and PNEUMODERME.

As the arrangement of Linnæus is still that which is most generally received, especially in this country, and is therefore most familiar to our readers, we shall follow it in this article.

¹¹
Generic
characters.

¹³
Of the in-
testina.

GENERIC CHARACTERS.

ORDO I. INTESTINA; animalia simplicia, nuda, artubus destituta.

* *Intra alia animalia degentia, oculis nullis.*

Gen. I. ASCARIS. Corpus teres, utrinque attenuatam; capite trinodi.

2. TRICHURIS. Corpus teres, posterior filiforme; capite rostrato.

3. FILARIA. Corpus filiforme totum.

4. UNICINARIA. Corpus filiforme, elasticum; capite labiato, labiis membranaceis; cauda (*feminae*) aciformi, (*maris*) uncinis duobus vesicæ pellucidæ inclusis armata.

5. SCOLEX. Corpus minimum, gelatinosum, opacum; capite exsertili et retractili, auriculis 4 pellucidis.

6. LIGULA. Corpus lineare, æquale, elongatum.

7. LINGUATULA. Corpus depressum, oblongum; ore anteriori ostiis 4 cincto.

8. STRONGYLUS. Corpus teres, elongatum; anteriori globoso-truncatum, apertura circulari margine ciliata; posteriori (*feminae*) acuminatum, (*maris*) cucullatum.

9. ECHINORHYNCHUS. Corpus teres; proboscide cylindrica retractili aculeis uncinatis coronata.

10. HÆRUCA. Corpus teres; capite aculeis coronato.

11. CUCULLANUS. Corpus posteriori acuminatum; anteriori obtusum; ore orbiculari.

12. CARYOPHYLLÆUS. Corpus teres, læve, ore amplo.

13. FASCIOLA. Corpus depressum, ovatum, poro terminali et laterali.

ORDER I. INTESTINA; animals simple, naked, and destitute of limbs.

* *Living within other animals, without eyes.*

A. Body round, tapering both ways; head furnished with three protuberances.

T. Body round, filiform behind; head furnished with a proboscis.

F. Body entirely filiform.

U. Body filiform, elastic; head with membranaceous angular lips; tail of the female needle-shaped, of the male armed with two hooks inclosed in a pellucid vesicle.

S. Body minute, gelatinous, opaque; head exsertile and retractile, with 4 pellucid auricles.

L. Body linear, equal, and long.

L. Body depressed, oblong; mouth placed on the fore part, and surrounded with 4 passages.

S. Body round, long; the fore part globular and truncate, with a circular aperture fringed at the margin; hind part of the female pointed, of the male hooded.

E. Body round; proboscis cylindrical, retractile, and crowned with hooked prickles.

H. Body round; head crowned with prickles.

C. Body pointed behind; the fore part obtuse, with an orbicular mouth.

C. Body round, smooth, with a large dilated mouth.

F. Body depressed, ovate, with a terminal and lateral pore.

- Genera. 14. *TENIA*. Corpus articulatum, depressum; anterius tubulo 4-fido instructum.
 15. *FURIA*. Corpus lineare, aculeis reflexis, utrinque ciliatum.

** *Extra alia animalia habitantia.*

† *Poro laterali nullo.*

16. *GORDIUS*. Corpus aequale, filiforme totum, teres, laeve.
 17. *HIRUDO*. Corpus anterius et posterius truncatum, ore caudaque progrediendo dilatata.

‡ *Poro laterali pertusa.*

18. *LUMBRICUS*. Corpus teres, annulatum; aculeis conditiis.
 19. *SIPUNCULUS*. Corpus teres, rostro cylindrico angustato.
 20. *PLANARIA*. Corpus depressum, poro ventrali.

¹⁴ Of the mol-
lusca. ORDO II. MOLLUSCA. Animalia simplicia, artubus instructa.

* *Ore supero.*

21. *ACTINIA*. Apertura unica communi, dilatabili, nuda, basi affixa.
 22. *CLAVA*. Apertura unica communi, dilatabili, verticali, tentaculis clavatis cincta.
 23. *PEDICELLARIA*. Corpus pedunculatum, fixum; pedunculo rigido.
 24. *MAMMARIA*. Apertura unica, cirris nullis, laevis.
 25. *ASCIDIA*. Aperturis duabus, altera humiliori affixa.
 26. *SALPA*. Aperturis duabus, utraque terminali.
 27. *DAGYSLA*. Aperturis duabus; corpus angulatum.

** *Ore antico.*

28. *PTEROTRACHEA*. Corpus pervium, gelatinosum, pinna mobili ad abdomen vel caudam.
 29. *DERRIS*. Corpus teres, acuminatum articulatum; tentacula 2.

*** *Corpore pertuso foraminula laterali.*

30. *LIMAX*. Tentacula 4. Anus communis cum poro laterali.
 31. *LAPLYSIA*. Tentacula 4; anus supra posteriora.
 32. *DORIS*. Tentacula 2; anus supra posteriora.
 33. *TETHIS*. Foramina lateralia sinistra gemina.

**** *Corpore tentaculis antixis cincto.*

34. *HOLOTHURIA*. Tentacula carnosae.
 35. *TERREBELLA*. Tentacula capillaria.

***** *Corpore brachiata.*

36. *TRITON*. Brachia 12, bipartita, quibusdam cheliferis.

T. Body flat, jointed, furnished before with 4 orifices.

F. Body linear, with each side ciliated with reflected prickles.

** *Not inhabiting other animals.*

† *Having no lateral pore.*

G. Body equal, filiform, round, and smooth.

H. Body truncate at each extremity; head and tail dilated when in motion.

‡ *Perforated with a lateral pore.*

L. Body round, annulate, furnished with minute hidden prickles.

S. Body round, with a cylindrical mouth, narrower than the head.

P. Body flattened, with a ventral pore.

ORDER II. MOLLUSCA. Animals simple, furnished with limbs.

* *With the mouth placed above.*

A. Body fixed, with a single terminal dilatible aperture, surrounded by tentacula.

C. Body fixed, with a single dilatible vertical aperture, surrounded with clavate tentacula.

P. Body fixed and furnished with a rigid peduncle.

M. Body loose, smooth, with a single aperture without cirri.

E. Body fixed, with two apertures, one of which is terminal, the other placed a little beneath.

S. Body loose, with two apertures, one at each end.

D. Body loose, angular, open at each end.

** *Mouth placed before.*

P. Body pervious, gelatinous, with a moveable fin at the head or tail.

D. Body round, tapering, articulate; feelers 2.

*** *Body with a lateral perforation.*

L. Feelers 4; vent common with the lateral pore.

L. Feelers 4; vent placed above the lower extremity.

D. Feelers 2; vent above the lower extremities.

T. Body with two small pores on the left side.

**** *Body surrounded with feelers on the fore part.*

H. Feelers fleshy.

T. Feelers capillary.

***** *Body furnished with arms.*

T. Arms 12, divided, some of them cheliferous.

- | | |
|--|---|
| <p>Genera.</p> <p>37. <i>SEPIA</i>. Brachia 8—10, instructa cotylis.</p> <p>38. <i>CLIO</i>. Brachia 2, aliformia, extensa.</p> <p>39. <i>ONCHIDIUM</i>. Brachia 2, dilatata ad latera capitatis.</p> <p>40. <i>LOBARIA</i>. Corpus supra convexum, subtus planum, lobatum.</p> <p>41. <i>LERNEA</i>. Brachia 2—3, teritia, tenuia.</p> <p>42. <i>SCYLLÆA</i>. Brachia 6, paribus remotis.</p> | <p>S. Arms 8—10, beset with suckers.</p> <p>C. Arms 2, dilated, extended like wings.</p> <p>O. Arms 2, dilated, and placed at the sides of the head.</p> <p>L. Body convex above, flat below, lobate.</p> <p>L. Arms 2—3, round and slender.</p> <p>S. Arms 6, each pair at a distance.</p> |
|--|---|

***** *Corpore pedato.*

43. *APHRODITA*. Corpus ovale, ocellatum; tentacula duo, setacea, annulatum.
44. *AMPHITRITE*. Corpus tubo extrusum, annulatum; tentacula pinnata, oculi 0.
45. *SPIO*. Corpus tubo extrusum, articulatum; tentacula duo simplicia; oculi duo.
46. *NEREIS*. Corpus elongatum repens; pedunculis lateralibus pennicillatis; tentacula simplicia.
47. *NAIS*. Corpus elongatum, repens; pedunculis setaceis simplicibus; tentacula nulla; oculi nulli vel 2.

†† *Ore infero, ut plurimum centrale.*

48. *PHYSSOPHORA*. Corpus gelatinosum, e vesicula aërea pendens.
49. *MEDUSA*. Corpus gelatinosum, læve.
50. *LUCERNARIA*. Corpus gelatinosum, rugosum, brachiatum.
51. *ASTERIAS*. Coriaceum, muricatum.
52. *ECHINUS*. Corpus crustaceum, aculeatum.

***** *Body furnished with feet.*

- A. Body oval, furnished with eyes; feeler 2, setaceous, annulate.
- A. Body proceeding from a tube, and annulate; feelers feathered; eyes wanting.
- S. Body proceeding from a tube, and jointed; feelers 2, simple; eyes 2.
- N. Body long, creeping, with lateral pencilled peduncles; feelers simple.
- N. Body long, creeping; peduncles furnished with simple bristles; feelers none; eyes 0 or 2.

†† *Mouth beneath, commonly central.*

- P. Body gelatinous, hanging by an air bubble.
- M. Body gelatinous, smooth.
- L. Body gelatinous, wrinkled, furnished with arms.
- A. Body coriaceous, flat, generally radiate and muricate with papillæ.
- E. Body crustaceous, and covered with moveable spines.

15
Of the
Zoophyta.

ORDO IV. ZOOPHYTA. Animalia composita, more vegetabilium, efflorescentia.

* *Stirps calcarea. Lithophyta.*

53. *TUBIFORA*. Corallium tubis cylindricis.
54. *MADREPORA*. Corallium, stellis concavis.
55. *MILLEPORA*. Corallium, poris subulatis.
56. *CELLEPORA*. Corallium, cellulis cavis.
57. *ISIS*. Stirps lapidea.

ORDER IV. ZOOPHYTES. Compound animals, shooting up like vegetables.

* *With a calcareous stem. Lithophyta.*

- T. Coral, with cylindrical tubes.
- M. Coral, with concave stars.
- M. Coral, with subulate pores.
- C. Coral, with hollow cells.
- I. Stem stony.

** *Stirps molliore.*

58. *ANTIPATHES*. Stirps cornea, spinulis obsita, carne gelatinosa tecta.
59. *GORGONIA*. Stirps cornea, carne cellulosa seu vasculosa tecta.
60. *ALCYONIUM*. Stirps suberosa.
61. *SPONGIA*. Stirps stuposa, flexilis, bibula.
62. *FLUSTRA*. Stirps porosissima.
63. *TUBULARIA*. Stirps tubularis, filiformis.
64. *CORALLINA*. Stirps articulis filiformibus calcareis.
65. *SERTULARIA*. Stirps articulis filiformibus fibrosis.
66. *PENNATULA*. Stirps coriacea, penniformis.
67. *HYDRA*. Stirps medullosa, nuda.

** *With a softer stem.*

- A. Stem horny, beset with small spines, and covered with a fleshy gelatinous coat.
- G. Stem horny, and covered with a cellular or fleshy vascular coat.
- A. Stem like cork.
- S. Stem stringy, flexile, and bibulous.
- F. Stem extremely porous.
- T. Stem tubular, filiform.
- C. Stem jointed, filiform, calcareous.
- S. Stem jointed, filiform, fibrous.
- P. Stem leathery, resembling a quill.
- H. Stem medullous, naked.

Species.
Intestina. ORDO V. INFUSORIA. Animalia minima simpli-
ciora.

ORDER V. INFUSORIA. Animals extremely mi-
nute and simple.

Species.
Intestina.

† *Organis externis.*

† *Furnished with external organs.*

68. BRACHIONUS. Corpus testa tectum, apice cilia-
tum.
69. VORTICELLA. Corpus nudum, apice ciliatum.
70. TRICHODA. Corpus altera parte crinitum.
71. CERCARIA. Corpus rotundatum caudatum.
72. LEUCOPHRA. Corpus undique ciliatum.

- B. Body covered with a shell, and ciliate at the tip.
V. Body naked, and ciliate at the tip.
T. Body hairy on one side.
C. Body rounded and furnished with a tail.
L. Body everywhere ciliate.

†† *Organis externis nullis.*

†† *Without external organs.*

73. GONIUM. Corpus angulatum.
74. COLPODA. Corpus sinuatum.
75. PARAMESIUM. Corpus oblongum.
76. CYCLIDIUM. Corpus orbiculare vel ovatum.
77. BURSARIA. Corpus cavum.
78. VIBRIO. Corpus elongatum.
79. ENCHELIS. Corpus cylindraceum.
80. BACILLARIA. Corpus ex trabeculis in varias
formas accommodatis compositum.
81. VOLVOX. Corpus sphericum.
82. MONAS. Corpus punctiforme.

- G. Body angular.
C. Body sinuate.
P. Body oblong.
C. Body orbicular or ovate.
B. Body hollow.
V. Body elongated.
E. Body cylindraceous.
B. Body composed of straight straw-like filaments,
in position.
V. Body spherical.
M. Body a mere point.

CHAP. II. CLASSIFICATION AND NATURAL HISTORY OF THE SPECIES.

SECT. I.

ORDER. I. INTESTINA.

LINNÆUS gave the name of *intestina* to this order, from the circumstance of their living in concealed situations: while others have denominated these worms *intestinal*, from the ordinary habitation of many of them; viz. the intestines of other animals. As all of this order, however, do not live in these situations, the term is not strictly proper. It would perhaps be better to follow the example of Goeze, and arrange all the parasitical worms in a separate order.

The most esteemed works on the subject of the *intestina*, are those of Pallas, *De infestis viventibus intra viventia*; Muller, *Historia vermium*; Bloch, a work in German, afterwards translated into French; Goeze, who also published in German; Werner, Lamarck, Latreille; and two papers by our countrymen Mr Carlisle and Dr Hooper, which will be mentioned particularly hereafter.

Anatomists have not examined a sufficient number of these animals, to render an account of their general structure either accurate or interesting; but we shall take occasion to detail that of some of the more important species under their proper heads.

There is nothing in the economy of animals more obscure, than the origin of those intestinal worms which inhabit within other animals. Were they found to live out of these animals, it might easily be supposed that their ovula were taken with the food and drink into the body, and there gradually evolved into perfect worms.

This, however, is not the case; most of them do not seem capable of living for any length of time in any other situation than within a living animal body, which appears to be the proper place for their growth and residence. We might hence be led to another supposition; that these worms are really formed from the matter within the intestines, which had previously no regular organization, were not this idea widely different from all analogy in the production of animals, where there has been any proper opportunity of examining this production. The origin, therefore, of these animals is a subject of much obscurity. Dr Baillie is of opinion, that when the whole evidence in support of both hypotheses is compared, the grounds for believing that, in some orders of animals, equivocal generation takes place, appear stronger than those for a contrary opinion*.

* *Morbid Anatomy,*
chap. viii.

I. ASCARIS.

Body round, elastic, and tapering towards each extremity; and furnished with three vesicles; tail either subulate or obtuse; intestines spiral, white, and pellucid.

This tribe is one of the most numerous of these parasitical worms, late dissections having discovered species of it in a great variety of animals, quadrupeds, birds, fishes, insects, and even worms themselves. The most important are those which inhabit the human intestines; and to these we shall chiefly confine our attention, availing ourselves of the excellent paper on these worms inserted by Dr Hooper in the 5th volume of the Memoirs of the Medical Society of London.

Species.
Intestina.A. *Infesting Man.**lumbri-
coides.*

Head slightly curved inwards, with a transverse contraction beneath it; mouth triangular. Fig. 1. and 2.

When full grown, they are from 12 to 15 inches in length; and in circumference equal to that of a goose quill.

The head is to be distinguished from the tail by a small contraction, very obvious when the worm is lying down; it is trilobated, having three vesicles and a triangular aperture, between which is the mouth. These three globose papillæ are joined together at their basis, and are of the same colour as the rest of the worm.

The tail may be known from the head by its very acute termination, close to which is a large orifice, the extremity of the intestinal canal, which may be termed the anus.

The body is that part between the two extremities, forming nearly the whole of the worm; it puts on a rugose appearance, and has a line very apparent running on each side, and extending from one end to the other. Between these two lines are two other lines running parallel with the former, scarcely visible. Near the middle of the body (rather towards the head) is a circular depression of about one-fourth of an inch in extent, in which is a very small punctiform aperture. This depressed band is irregular in its appearance, when the body of the worm is distended, although it would appear to be wanting when collapsed, in which state it mostly escapes from the intestines.

They generally infest the small intestines, and of these more frequently the course of the jejunum and ileum. Sometimes they are known to ascend through the duodenum into the stomach, and are frequently seen to creep out at the mouth and nostrils; it happens but rarely that they descend into the large intestines, and only after the exhibition of worm medicines, or from other causes, which increase the peristaltic motion. They have also been detected, after death, in the common biliary duct, and instances are related where they have remained a considerable time in the gall bladder.

They are in general very numerous, and Dr Hooper relates an instance of above two hundred having been voided in the course of a week. Thirty or forty is a very common number, but now and then only one is found.

When recently excluded they are transparent, and appear as if they had been sucking water tinged with blood; this colour, however, soon disappears, and they become at length of a light and opaque yellow.

When voided they are in general very feeble and soon die, but when suddenly expelled, they sometimes appear very lively. Their motion is serpentine, but is not produced by the diminution of the length of the animal by contraction. The head is sent forward by the worm curling in itself into circles, and suddenly extending itself with considerable force to some distance.

This species does not, like most of this order, appear to be hermaphrodite, but the male and female are said to be distinct worms.

The covering or external membrane of the worm, which may be considered as the cuticle, is very strong, elastic, thin, smooth, and transparent; and easily sepa-

rates from the parts beneath, if the worm be macerated a few days after death in water.

Under the cuticle lies the cutis, or true skin, which is considerably thicker than the former, and retains the marks of the muscles which it covers. It is also very strong, elastic, and transparent.

When the cutis is removed, the muscles, observable through the skin of the worm, present themselves. They do not entirely surround the worm, as from their appearance one would be induced to believe; but are, in fact, two distinct orders acting in opposition to each other; for the two longitudinal lines, which extend from one extremity of the worm to the other, are each of them composed of two distinct tendons, separable from one another. These tendons serve for the attachment of the circular muscles, which cover the worm from the head to the tail.

Upon removing carefully the semilunar muscles from the head to the depressed band, a number of minute vesicles are to be seen (by means of a glass) filled with a submucous fluid, which issues out upon puncturing them.

This cellular or parenchymatous apparatus, closely embraces the intestinal tube from the head to the depressed band; but from thence to the tail, there is merely a fibrous connecting substance, similar to what is generally called cellular membrane.

When the muscles are removed from the depressed band to the tail of the worm, an extremely delicate membrane presents itself, analogous to the peritoneum, for it embraces the abdominal viscera, and lines the cavity of the abdomen.

The cavity of the abdomen extends from the depressed band near the middle of the worm to the tail; it is mostly distended with a transparent fluid, and contains the intestinal tube and an apparatus supposed to be subservient to generation, which constitute the abdominal viscera.

The intestinal canal begins at the obtuse extremity or head, from the external triangular mouth situated between the three globose papillæ, and is continued for a small space downwards (nearly half an inch) in a parallel form. Having attained the size of a crow quill, it passes in a straight direction (and gradually enlarges as it advances) through the whole length of the worm, to within the eighth part of an inch, where it becomes suddenly narrower, and terminates in the anus.

This canal is generally filled with a greenish-coloured fluid, of the consistence of mucus, and not very unlike the meconium of infants.

If a portion of this tube be macerated for a few days in water, it exhibits distinct coats, the external of which is a production of the peritoneum; it is externally covered with filaments, which connect it to the abdominal parietes. The second viscus is considered by some as peculiar only to the female worm, but all agree, that it is for the purpose of generation. It begins near the middle of the worm, where the cavity of the abdomen commences, by a slender tube, which is continued from the punctiform aperture, situated in the depressed band between the two longitudinal lines. This tube, which is termed the vagina, soon becomes much larger, when it commences uterus, and divaricates into two large crura, which, for the space of four or five inches, are continued of an uniform diameter; they then on a sudden

Species.
Intestina.Plate
CCLL.
Fig. 1.

Species Intestinal. sudden, become much diminished in size, and appear like opaque threads, embracing in every direction, the intestinal tube. These are by Werner considered as the fallopian tubes.

This convoluted apparatus is composed of very fine transparent membranes. It is never found empty, but is always distended with an opaque fluid, in which are a number of globular bodies, or ovula, containing young worms.

It has been supposed by some that these worms are viviparous; an opinion which seems to have arisen from mistaking the nature of an appearance that not unfrequently takes place; viz. a protrusion of the gyrated apparatus above described, the filaments of which look very much like young worms. A convincing proof of their being oviparous is afforded by the fact, that ovula, differing in no respect from those found in the uterus of the worm, have been found in the mucus of the intestines by which they are surrounded.

This species was long considered as the same with the common earth worm, to be mentioned presently. There are, however, many striking differences, which will be enumerated under that species.

Head subulate; skin at the sides of the body very finely wrinkled. Vid. fig. 3. and 4.

When full grown, it is about half an inch long, and in thickness resembles a fine piece of thread. The body forms about a third part of the length of the animal, beginning immediately from the head, and terminating in the tail, which is distinguished by its gradually diminishing. The worm is wrinkled, annular, and pellucid. The tail terminates in a fine point; and when viewed with a magnifying glass, appears furnished with wrinkles or thick firm rings, and at its beginning there is a small opening through which the excrements pass.

They are most commonly situated in the rectum, and are continually passing away. They are frequently met with in the cæcum and colon, and have been found in the stomach and small intestines, lying hid between their coats. They are generally in considerable numbers, especially in the rectum of children; when they inhabit other parts, their numbers are less considerable, though above an hundred have been known to be vomited from the stomach of a young woman in the course of a day †.

Their natural colour is a pale yellow, though they are often observed of a pale green, or occasionally of a brown colour.

When the animal wishes to shift his place, he first moves his head, which he turns in every direction, sometimes in a circle, at others so as to form the figure eight; most commonly its tail appears fixed, while it turns its body sometimes to one side, and sometimes to another. They are extremely lively, and have been seen to bury themselves almost instantaneously in the soft fæces of children, when they are exposed to the air. By some they are said to jump from one place to another; and hence the name *ascarides*, or *leaping worms*, from *urnaxi* *sur*, to leap.

These animals are certainly male and female, and, unlike the last species, they are viviparous.

The integuments of this species resemble those of the last, but there do not appear to be any longitudinal bands on its surface. The cavity, in which the bowels are situated, begins at a very small distance from the

head, and terminates at the commencement of the tail. The only viscera in the male worm are the gullet, the stomach, and the intestine. The *gullet* begins at the mouth, from which it gradually enlarges for a small space, till it terminates in the stomach. This is a roundish bag, forming with the gullet, an organ shaped like the pestle of a mortar. The intestinal canal is continued, more or less contracted or dilated, till it terminates in the anus. The contents of this canal are always of a dark brown colour.

Besides these organs, the female has an apparatus appropriated to generation. It begins by a slender tube leading from a very small opening that is situated nearly in the middle of the body of the worm. It soon becomes much larger, embraces the intestinal tube in every direction, and fills up the cavity of the worm. It is nearly of an equal size throughout, and when viewed with a microscope, it appears like a bladder distended with living worms.

Various mammalia are also infested with ascarides, of which the following species are enumerated.

A. vesperilionis, found in the long-eared bat; *pho-mammæ*, found in several species of seal; *bifida*, inhabiting *lium*. the phoca Greenlandica, or Greenland seal; * *canis*, in the intestines of the dog; *visceralis*, in the kidneys of the same animal; *lupi*, in the wolf; *vulpis*, in the fox; *leonis*, found under the skin of the lion; *tigridis*, in the intestines of the tiger; *felis* and *cati*, both found in the cat; *martis*, in the intestines of the martin; *bronchialis*, in the lungs, and *renalis*, in the kidneys of the same animal; *mephitidis*, in the viscera of the skink; *gulonis*, in the glutton; *talpæ*, in the mole; *muris*, in the mouse; *hirci*, in the goat; *vituli*, in the lungs of cattle; * *equi*, in the horse; *suis*, in the intestines of swine, and *apri*, in the lungs of the boar.

The following species are found in birds.

A. Aquilæ, in the eagle; *albicillæ*, in the intestines *avium*. of the falco albicilla; *buteonis*, in the buzzard; *milvi*, in the kite; *sabbuteonis*, in the hobby; *hermaphrodita*, in the psittacus æstivus; *cornicis*, of the crow; *coracis*, in the skin about the throat of the roller; *cygni*, in the swan; *anatis*, in the wild duck; *fuligulæ*, in the tufted duck; * *carbonis*, in the corvorant; * *pelicani*, in the shag; *lari*, in the gull; *ciconiæ*, in the stork; *tardi*, and the *papillosa*, in the intestines of the buzzard; *gallopavium*, in the turkey; *galli*, in young fowls; *gallinæ*, in the hen; *phasiani*, in the phasianus pictus; *tetraonis*, in the grouse; *colombæ*, in the house pigeon; *alaudæ*, in the lark; *sturni*, in the starling, and *turdi*, in the thrush.

The following infest reptiles.

A. testudinis, the round tortoise; *lacertæ*, the newt; *reptilium*. *bufonis*, the toad; *pulmonalis*, the lungs of the toad; *rubetræ*, also in the toad and natter jack; *trachealis*, in the lungs of the toad; *ranæ* and *intestinalis*, found in the intestines of frogs; *dyspneos*, in the lungs of frogs, so as to impede their respiration; and *insons*, also found in the lungs of frogs, but without impeding their breathing.

The following infest fish.

Anguillæ, found in the eel; * *marina*, in herrings, *piscium*. bleaks, and other fish; *blennii*, in the blenny; *rhombi*, in the pearl; *percæ*, in the perch; *globicola*, found in the three-spined stickle-back; * *lacustris*, in the stickle-back and pike; *siluri*, in the silurus glanis;

† *Med. Soc. Mem. vol. v. p. 284.*

* *vermicularis.* Fig. 3. and 4.

Species Intestina.

Species. farionis, in the trout; truttæ, in the trout; murænae, in the salmo muræna; acus, in the common pike; hal-
Intestina. lecis, in the herring; argentioæ, in the argenteus or silver fish; gobionis, in the liver of the gudgeon; rajæ, in the tail-ray; squalæ, in the shark; and lophii, in the gullet of the frog fish.

lumbrici. One species, viz. *A. lumbrici*, is found in lumbrici, between the skin and humours, though it is so small, as to be visible only by means of a microscope.

The species of *ascaris* already known, amount to about eighty.

"We are not to suppose (says Mr Bingley) that these worms are created for the purpose of producing disease in the animals they inhabit, but rather, that nature has directed that no situation should be vacant, where the work of multiplying the species of living creatures could be carried on. By thus allowing them to exist within each other, the sphere of increase is considerably enlarged. There is, however, little doubt that worms, and more especially the tape worms (*to be presently described*), do sometimes produce diseases in the body they inhabit; but we are at the same time very certain, that worms do exist abundantly in many animals without at all disturbing their functions, or annoying them in the slightest degree; and we ought to consider all the creatures rather as the concomitants than the causes of disease*."

* *Animal Biography*, vol. iii. p. 490.

17
Trichuris.

2. TRICHURIS.

Body round, elastic, and variously twisted; head much thicker than the other part, and furnished with a slender, exsertile proboscis; tail long, capillary, and tapering to a fine point.

* *hominis.*
Fig. 5. and 6.

Body above slightly crenate, smooth beneath, and very finely streaked on the fore part. Vid. fig. 5. and 6.

The body, when full grown, equals in breadth the one-sixteenth of an inch. In length the whole worm measures nearly two inches, two-thirds of which are tail, hence the French call it *le ver à queue*.

The large extremity of the trichuris is the head, out of which proceeds a kind of proboscis, not always visible; for the animal has the power of ejecting and drawing within itself this instrument at pleasure.

The body may be said to begin at the basis of the proboscis; it is the thickest part of the worm, and the most so at the extremity, where the proboscis is received. It gradually diminishes in size as it proceeds, and forms about one-third of its length.

The tail commences where the body terminates. It is twice as long as the body, and appears like a fine hair, gradually becoming smaller, and at length terminates in a very fine point.

Upwards of twenty have been seen in some faces of a child six years old, and according to the account of Blumenbach, they are, in general, in considerable number.

Wrisberg, Blumenbach, and others, have found these worms in the intestinum rectum, in the inferior part of the ileum, and also in the jejunum, mixed with their pultaceous contents. They have seldom, if ever, been seen after death, but in the cæcum. In colour it resembles the *ascaris vermicularis*.

Goetze has given a drawing of a female trichuris, and

says it has no proboscis, which he supposes to be the male organ of generation; but as there is no material difference in the viscera of particular individuals, Dr Hooper is inclined to doubt the fact.

Species.
Intestina.

This curious and singular animal is supplied, like the foregoing genus, with annular muscles, cutis, and cuticle.

The proboscis, which is undoubtedly the head of the worm, appears to be formed of a transparent substance, and contains a canal which is continued through the pulpy or funnel-like portion to the stomach and intestine.

The stomach and intestine are formed by a long canal, which proceeds in a direct line from the head to the very extremity of the worm. It is largest at its beginning, and continues of the same size throughout the body of the animal; and when arrived at the place where the tail commences, it suddenly becomes considerably less in diameter, and terminates in the anus.

The remaining viscus, or ovarium, is a convoluted canal, similar to that of the female *vermicularis* *ascaris*, but is seldom found embracing the intestinal tube. The contents of this canal are ovula and a limpid fluid. There have seldom been seen any young worms*.

* *Mem. Med. Soc. mammali-*

Besides the above species, five others have been described; viz. *T. equi*, found in the intestines of the horse; *apri*, in the boar; *muris*, in the mouse; *vulpis*, in the fox; and *lacerta*, in the lacerta *opus*.

3. FILARIA.

18
Filaria.

Body round, filiform, equal, and quite smooth; mouth dilated, with a roundish concave lip.

The most important species of this genus is the *F. medinen-medinensis*, or guinea worm. Gmelin has arranged the animal as a filaria, though Linnæus makes it a species of *gordius*, in which he is followed by Brugiere and Barbut. Mr Bingley, in his *Animal Biography*, chooses to consider it as the same with the *furia infernalis* of Linnæus, a species to be mentioned by and bye. The French call it *dragonneau*, and the older medical writers, *dracunculus*. It is characterised by having the body entirely of a pale yellow colour. It inhabits both the Indies and the coast of Guinea, and is said commonly to make its appearance in the morning dew. It enters the feet and other exposed parts of the slaves, and occasions very troublesome symptoms.

It attacks most parts of the body; but is generally confined to the lower extremities, particularly to the feet and ancles. The disease is more painful and dangerous when seated in parts thinly covered with flesh, such as near the joints, tendons, and ligaments, and less so in muscular parts. It is always difficult to extract the worm from the ancles, tarsus, and metatarsus, and sometimes impossible from the toes. The consequences frequently are, tedious suppurations, contractions of the tendons, diseased joints, and gangrene. When pulled, the worm often excites a pain which it is not easy to describe, and which, in these parts, is extremely exquisite. It seems to attach itself to the nerves, ligaments, and tendons, and when pulled even with the slightest force, excites excruciating pain. The track of the animal appears to be for the most part con-

finied

Species Intestina- fined to the cellular membrane, and probably seldom extends deeper, or penetrates into the interstices of the muscles.

Edin. Med. Journ. vol. ii. p. 145. The disease produced by this animal is a species of inflammation, which sometimes is very troublesome, and now and then is said to terminate in mortification. The worm sometimes appears at first like a hair, and becomes thicker as it is drawn from below the skin. It generally has a sharp point, and is otherwise all of the same thickness. It may sometimes be felt below the skin, like the string of a violin. Various causes are assigned for the generation of this worm, but in the countries where it is usually found, it is thought to be generated by drinking impure water. It is more probable that it insinuates itself from without.

The method commonly employed for extracting this animal is, to search for its extremity in the inflamed part, where there is usually an ulcer, and this is to be drawn out gently, and wrapt round a piece of linen rag, when the pulling is continued very gently till the worm makes so much resistance that there is great danger of breaking it, an accident which is said to be attended with very bad consequences, as the remaining part of the worm becomes more irritating, and produces a more violent degree of inflammation. When no more will easily come away, the part already extracted, rolled round the rag, is left to dry, the part covered from the air, and the operation is repeated occasionally till the whole worm is withdrawn.

mammalia-um. Four species of filaria are found in some of the mammalia, viz. *F. equi*, in the cellular membrane of the horse; *leonis*, in the lion; *martis* in the martin; and *leporis*, in the hare.

avium. Five infest birds, viz. *F. falconis*, the hawk; *strigis*, the owl; *cornicis*, the crow; *ciconiæ*, the stork; and *gallinæ*, the intestines of poultry.

insectorum. The following infest perfect insects, viz. *F. scarabæi*, the scarabæus semitarcus; *silphæ*, in the silpha obscura; *carabi*, in the carabus; *grylli*, in the cricket, and *monoculi*, in the monocolus apus.

Thirteen are found in the larvæ of various species of insects.

There are about 28 species of this genus distinguished in the *Systema Natura*.

4. UNCINARIA.

Uncinaria. Body filiform, elastic, the fore part obscurely tuberculate, with membranaceous angular lips; tail of the female ending in a fine point, of the male armed with two cuspidate hooks enclosed in a pellucid vesicle.

Of this genus there are only two species; viz. *melle*, found in the intestines of the badger; and *vulpis*, in those of the fox.

5. SCOLEX.

Scolex. Body gelatinous, variously shaped, broadish on the fore part and pointed behind; sometimes linear and long, sometimes wrinkled and short, round, flexuous, or depressed; the head protrusile and retractile.

This genus also contains two species; viz. *pleuro-nectidis*, and *lophii*, both found in several species of fish.

6. LIGULA.

Body linear, equal, long; the fore part obtuse, the hind part acute, with an impressed dorsal suture.

There are two species of this genus, viz. *intestinalis* and *abdominalis*, infesting several varieties of fish.

7. LINGUATULA.

Body depressed, oblong; mouth placed before, surrounded with four passages.

Of this genus there is only one species, viz. *serrata*, found in the lungs of the hare.

8. STRONGYLUS.

Body round, long, pellucid, glabrous; the fore part globular, truncate, with a circular aperture fringed at the margin; the hind part of the female entire and pointed, of the male dilated into loose, distant, pellucid membranes.

There are two species, viz. *equinus*, found in great numbers in the intestines of the horse, and *ovinus* in those of sheep.

9. ECHINORYNCHUS.

Body round; proboscis cylindrical, retractile, and crowned with hooked prickles.

This is a very numerous genus, and is found in a great variety of animals, generally in their intestines, to which they are found very firmly fixed, often remaining on the same spot during the whole life of the animal. They are commonly gregarious, and are to be distinguished from the *tænia*, to be presently described, by their having the body round, and destitute of joints.

Four species infest the mammalia, viz. *E. phocæ*, *mammalium*, rough seal, so as sometimes nearly to devour them; *tubifer*, in the stomach of the harp seal; *gigas*, in swine, especially those kept in styes; and *balenæ*, in the intestines of the whale.

14 infest birds, viz. *E. buteonis*, the buzzard; *scopis*, in the strix scopo; *aluconis*, in the strix aluco; *strigis*, in the tawney owl; *pici*, in various species of picus; *borealis*, in the eider duck; *boschadis*, in the common duck; *anatis*, in the velvet duck; *mergi*, in the mergus minutus; *alcæ*, in the auk; *ardææ*, and *gazæ*, in the ardea alba, or white heron; *vanillæ*, in the lapwing, and *merulus*, in the blackbird and tree sparrow.

Two infest reptiles, viz. *E. ranæ*, the frog; and *fal-reptilium*, the salamander.

28 infest fish; viz. *E. anguillæ*, the eel; *xiphia*, the sword-fish; *candidus*, found in several species of fish; *lineolatus*, in the cod; *longicollis*, in the torsk; *pleuronectis*, in the turbot; *attenuatus*, in the flounder; *annulatus*, in the father-lasher, torsk, and bream; *platesoides*, in the pleuronectes platessoides; *percæ*, in the perch; *cernuæ*, in the ruffe; *cobites*, in the bearded loach; *salmonis*, in the salmon; *sublobatus*, and *quadrirostris*, found also in salmon; *truttæ*, in the trout;

Species Intestina-
21
Ligula.

22
Linguatula

23
Strongylus

24
Echinorynchus

Species. *murænae*, in the salmo *muræna*; *lucii*, in the pike; *argentinae*, in the argentine; *alosa*, in the shad; *barbi*, in the barbel; *carpionis*, in the carp; *idbari*, in the cyprinus *idbarus*; *affinis*, in the roach; *rutili*, also found in the roach, but seldom; *bramæ*, in the bream; *lophii*, in the frog-fish, and *sturionis*, in the sturgeon. There are in all about 48 species.

semblance to the seed of the common gourd, whence it is often called the *gourd worm*.

The opinion of flukes being the cause of the rot, has been ably controverted by several writers, especially by Dr Harrison. On this subject, see the article *FARRIERY*, N^o 526. This opinion is supposed to be corroborated by a circumstance related in the first volume of the Monthly Magazine, page 101. of a jelly-like substance being found among the grass, in a pasture that was notorious for rotting sheep. This substance bore a striking resemblance to the flukes found in the liver of rotten sheep; but we are afterwards told, that having been washed into a ditch, and attended to daily, it was, in process of time, transformed into a small snail, with an ash-coloured spiral shell. It is therefore probable that it was not flukes; and indeed there is no well authenticated instance of these animals having been found out of the bodies of sheep, except when it could be proved, that they had been vomited by those animals.

25
Hæruca.

10. HÆRUCA.

Body round, the fore part two-necked, and surrounded with a single row of prickles; proboscis none.

There is only one species, viz. *H. muris*, found in the intestines of the mouse.

26
Cucullanus.

11. CUCULLANUS.

Body sharp, pointed behind, and obtuse before; mouth orbicular, with a striate hood.

There are eight species, three of which are found in various mammalia, viz. *C. talpæ* and *ocreatus* in the mole; and *muris* in the mouse.

mammalium.

One infests birds, viz.

C. buteonis, commonly found in the buzzard.

One, viz.

ranæ.

C. ranæ, is found in the intestines of the frog.

piscium.

Several varieties under the common name of *lacustris*, and two others, called *ascaroides*, and *murinus*, are found in various species of fish.

27
Caryophyllæus.

12. CARYOPHYLLÆUS.

Body round; mouth dilated and fringed.

There is only one species, called *caryophyllæus piscium*, found in various species of fishes.

28
Fasciola.

13. FASCIOLA.

Body flattish, with an aperture or pore at the head, and generally another at a distance beneath, seldom a single one.

Cuvier remarks, that the body of the fasciola is extremely flat. They appear to be hermaphrodite, and are oviparous. They are found in almost every species of animals.

hominis.

One is found in man, though rarely, viz. *fasciola hominis*.

mammalium.

Twelve in various species of the mammalia, viz. *vulpis*, in the intestines of the fox; *putorii*, in those of the pole-cat; *melis*, in those of the badger; *vespertilionis*, in the intestines of the long-eared bat; *hepatica*, in the livers of sheep; *bovm*, in those of cattle; *porcorum*, in the liver of swine; *apri*, in that of the boar; *elaphi*, in the stomach of the stag.

hepatica or fluke.

Of these, the most important is the *fasciola hepatica*, or fluke, which is so common in the liver of sheep, in which it is supposed to be the principal cause of the rot.—This species is about an inch long, broadest on the fore-part, which is furnished with a large mouth. It terminates in a tube; the back is marked with a row of about eight longitudinal furrows. It is generally found fixed by two points, one at one extremity, and another at about the middle of the abdomen. It bears some re-

Nine species of *fasciola* are found in birds, viz. **avium.**

F. bilis, in the gall duct of the eagle; *buteonis*, in the buzzard; *milvi* and *strigis*, in the intestines of the kite; *pusilla*, found in the thorax of the strix alba; *anatis*, in the duck; *anseris*, in the goose; *gruis*, in the crane; and *ardææ*, in the bittern.

Three species infest reptiles, viz.

F. salamandri, the salamander; *ranæ*, the common frog, and *uncinulata*, the esculent frog.

21 inhabit various kinds of fish, viz.

F. Binodis, *disticha*, *anguillæ*, *scabra*, *eglefini*, *blennii*, *scorpii*, *platessæ*, *luciopercæ*, *percæ*, *lugæna*, *clavata*, *varica*, *ericiis*, *farionis*, *trutta*, *umblæ*, *lucii*, *halecis*, * *bramæ*, *jesis*.

One, viz.

F. loliginis, inhabits the *sepia loligo*, or cattle fish. **loliginis.**

14. TÆNIA.

Body usually flat, and composed of numerous articulations; head with four orifices for suction, which are seated a little below the mouth; mouth terminal, continued by a short tube into two ventral canals, and generally crowned with a double series of retractile hooks.

The species of this genus, which are very numerous, are distributed into three sections, according to the situation which they inhabit in various animals, &c.

A. Found in other parts besides the intestines, and furnished with a vesicle behind.

The species of this section are commonly known to medical writers by the name of *hydatida*, from the bladders, of which they are chiefly composed, being filled with a watery fluid.

The following inhabit various specimens of mammalia; *T. visceralis*, pisiform, inclosed in a vesicle, broad on the fore part, and pointed behind.—Found in the liver, placenta, kidneys, sacs containing dropsical fluids, and other morbid tumours in man.

There is no gland in the human body in which *hydatids* are so frequently found as the liver, except the kidneys, where they are still more common. *Hydatids* of the liver are usually found in a *cyat*, which is frequently of considerable size, and is formed of very firm

Species.
Intestina.

materials, so as to give to the touch almost the feeling of cartilage. This cyst, when cut into, is obviously laminated, and is much thicker in one liver than another. In some livers, it is not thicker than a shilling, and in others, it is near a quarter of an inch in thickness. The laminae which compose it are formed of a white matter, and on the inside there is a lining of a pulpy substance, like the coagulable lymph. In a cyst may be found one hydatid, or a greater number of them. They lie loose in the cavity, swimming in a fluid; or some of them are attached to the side of the cyst. They consist of a round bag, which is composed of a white, semi-opaque, pulpy matter, and contain a fluid capable of coagulation. Although the common colour of hydatids be white, yet they are seen occasionally of a light amber. The bag of the hydatid consists of two laminae, and possesses a good deal of contractile power. In one hydatid, this coat or bag is much thicker and more opaque than in another, and even in the same hydatid different parts of it will often differ in thickness. On the inside of an hydatid, smaller ones are sometimes found, which are commonly not larger than the heads of pins, but sometimes they are even larger than a gooseberry. These are attached to the larger hydatid, either at scattered irregular distances, or so as to form small clusters; and they are also found floating loose in the liquor of the larger hydatids. Hydatids of the liver are often found unconnected with each other; but sometimes they have been said to inclose each other in a series, like pill-boxes. The most common situation of hydatids of the liver, is in its substance, and inclosed in a cyst; but they are occasionally attached to the outer surface of the liver, hanging from it, and occupying more or less of the general cavity of the abdomen*.

Another species called *cellulosa*, is found in the cellular membrane of man.

The following infest others of the mammalia, viz. *T. simiae*, found in the diaphragm of the ape; *vesperilionis*, in the liver of the bat; *vulpis* in the fox; *putorii*, in the pole-cat; *ursi*, in the bear; *gulonis*, in the glutton; *hydatigena*, in various species of rat; *murina*, in the liver of the mouse; *cordata*, in mice and hares; *pisiformis*, in the liver of hares; *utricularis*, in the gravid uterus of the same animal; *ferarum*, in deers and antelopes; *caprina*, in the goat; *ovilla*, in the liver and omentum of sheep; *cerebralis*, within the skull of sheep, constituting the disease called *sturdy* or *turn-sick*; (see FARRIERY, N^o 521.) *verveoia*, in the peritoneum of fat sheep; *granulosa*, in the liver of sheep; *bovina*, in cattle; *apri*, in the boar; *globosa*, chiefly found in the bowels of swine; and *pinna*, in the cellular substance of swine.

Two infest reptiles, viz.

T. salamandri, the salamander; and *serpentum*, in various serpents.

One, viz.

T. truttæ, is found in the liver of the trout.

The origin and real nature of hydatids are not fully ascertained. There is no doubt at all, that the hydatids in the livers of sheep are animalcules; they have been often seen to move when taken out of the liver, and put into warm water; and they retain this power of motion for a good many hours after a sheep has been killed. The analogy is great between hydatids in the liver of a

sheep, and in that of a human subject. In both they are contained in strong cysts, and in both they consist of the same white pulpy matter. There is undoubtedly some difference between them in simplicity of organization; the hydatid in the human liver being a simple uniform bag, and the hydatid in that of the sheep having a neck and mouth appended to the bag. This difference need be no considerable objection to the opinion above stated. Life may be conceived to be attached to the most simple form of organization. In proof of this, hydatids have been found in the brains of sheep, resembling almost exactly those in the human liver, and which have been seen to move, and therefore are certainly known to be animalcules. The hydatids of the human liver indeed, have not, as far as we know, been found to move when taken out of the body and put into warm water: were this to have happened, no uncertainty would remain.

An excellent paper on the subject of hydatids, by Dr John Hunter, is contained in the Medical and Chirurgical Transactions.

B. *Having no terminal vesicle, and found only in the intestines of other animals.*

This section comprehends the *tæniæ* properly so called, or tape-worms, which are the most troublesome of all the species that inhabit the intestinal canal. Of these, the following two species that are confined to man, merit our particular attention.

Articulations long and narrow, with marginal mouths, *solium*. one on each joint, and generally alternate; ovaries arborescent. *Vide* fig. 7. and 8.

This species is frequently bred in the intestines of the inhabitants of Germany, and occasionally, but rarely, in those of the inhabitants of Great Britain. It consists of a great many distinct portions, which are connected together so as to assume a jointed appearance; these joints are commonly of a very white colour, but are occasionally brownish, which depends on a fluid of this colour that is found in their vessels. The worm is usually very long, extending often many yards, and seldom passes entire from the bowels. This circumstance has prevented the extremities of the *tænia* from being often seen.

Boerhaave mentions his having met with a *tænia* 30 ells in length, and Pliny says he has seen them upwards of 30 feet long. According to Dr Hooper, the exact length depends upon the manner in which the death of the animal has been occasioned. If expelled by irritating medicines, it will not be so long by nearly one-half as if its death had been occasioned by emollients; as in the former instance it would be very much contracted, but in the latter very much relaxed.

The head of this *tænia* is somewhat of a square form, with a narrowed projection forwards; in the middle of this projecting part, there is a distinct circular aperture, around the edge of which grow curved-shaped processes. Near the angles of the square edge of the head, are situated four round projecting apertures at equal distances from each other; this head is placed upon a narrow jointed portion of the worm, of considerable length, and which gradually spreads itself into the broader joints, of which the body of the worm is composed.

The body of the *tænia* consists of thin, flat, pretty long joints, on one edge of which there is a projection,

Species.
Intestina.

* Baillie's
Morbid
Anatomy,
chap. ix.
cellulosa
mammalia
lum.

reptilium.

truttæ.

30
Tape-worm

Fig. 7. and 8.

Species.
Intestina.

with a very obvious aperture. In the same worm some of these joints appear considerably longer than others; this probably depends on one joint being contracted, while another is relaxed. The apertures which we have just mentioned are generally placed on the edge of the contiguous joints; but this is not uniformly the case; they are sometimes placed on the same edges of two, or even several contiguous joints. When these joints are examined attentively, there are frequently seen, in each of them, vessels filled with a brownish fluid, and disposed in an arborescent form. Around the edges of each joint, there is also a distinct serpentine canal. The last joint of a *tænia* resembles very much a common joint rounded off at its extremity, and without any aperture.

The joints of this species are very easily separated from each other whilst the animal is alive. This separation is effected either by the peristaltic motion of the intestines, or perhaps spontaneously. Each joint thus detached from the mother worm, has the power of retaining, for a considerable time, its living principle, and is called, from its resemblance to the seed of the gourd, *vermis cucurbitinus*. This phenomenon has given rise to many warm disputes; several authors have denied their being portions of *tænia*, and have affirmed that they were distinct worms. The separated joints do not appear capable of retaining their situation for any length of time, but are soon forced down the intestinal tube, and at length creep out, or are expelled per anum. There are several cases faithfully recorded, where the persons, if their veracity can be depended upon (and they had no interest in deceiving), have voided, during the time they were troubled with the worm, upwards of fifteen thousand.

This worm is not in general solitary, as is commonly supposed, for several of them have been seen coming away at the same time.

They are always found in the small intestines, commonly occupying their whole extent.

The motion of these worms is undulatory. The first joint towards the head contracts; the succeeding ones follow successively, and the worm is at length drawn considerably forwards, exactly in the same manner in which the earth worm is seen to move, only considerably slower. By this means the food taken in at the mouth of the worm is very soon conveyed all along the alimentary canal, and may sometimes be seen moving along with considerable rapidity.

There can be very little doubt, that the *tænia* is hermaphrodite. The oscula are observed to be viscera, subservient to the propagation of the species, as it can be proved, that they give exit to the ova.

lata.

Articulations short and broader than those of the last, with a mouth in the centre of each joint; ovaries stillate round the mouth.

It is composed of a head, a chain of articulations, and a tail formed of a round joint, as in the last species. The head is similar to that of the other species.

The joints are more uniform in their appearance than those of the *tænia solium*. They are considerably more broad than long, and their oscula are not placed on the margin, but in the middle of the flattened surface, and only on one side. We have never seen them change their side, but have always observed

them on the same side throughout the whole extent of the worm.

Species.
Intestina.

In every other respect the description of this species agrees with that above given of the other, except that the ovaria are in the form of a rose or star, hence they are called by some writers, *ovaria rosacea*, and others, *stigmata rosacea*; and that the transverse canals by which there is in the other species a communication between the longitudinal canals are in this wanting.

The number of this species is uncertain, but there are seldom more than three or four.

Its length is commonly less than that of the last species, seldom exceeding five yards.

It is always situated in the small intestines, and it appears that it feeds on no other food than pure chyle.

It is for the most part of a darker hue than the former species, though they have been seen as white as milk.

This species is very seldom met with in this country, but is endemic in Switzerland and Russia, and very common in Germany and some other parts of Europe.

For a more particular account of the anatomical structure of *tæniæ*, we refer our readers to a paper by Mr Carlisle, in the second volume of the *Lin. Trans.* and Dr Hooper's paper in the fifth volume of the *Memoirs of the Medical Society of London*. For an account of the symptoms produced by these worms and the ascariides, and the method of treatment, see *WORMS, MEDICINE Index*; and for the remedies employed in these cases, see *ANTHELMINTICS, MATERIA MEDICA Index*.

The following species inhabit various mammalia, viz.

Catænoformis, of which there are seven varieties found in the dog, the wolf, the fox, the cat, the squirrel, and the dormouse; *cucurbitina*, in the dog; *serrata*, in the dog and cat; *maniliformis*, in the cat; *lineata*, in the wild cat; *mustelæ*, in the weazel, martin, and polecat; *filamentosa*, in the intestines of the mole; *erinacei*, in the hedge-hog; *straminea*, in the mus cricetus; *magna* and *quadriloba*, in the horse; and *caprina*, in the goat.

The following infest birds, &c.

Psittaci, in the *psittacus brachyurpus*; *cornicis, avium*, in the crow; *serpentiformis*, in crows, rooks, and magpies; *caryocactus*, in the nut-cracker; *crateriformis*, in the spotted wood-pecker; *torqueta*, in the duck; *scolopacis* and *filum*, in the woodcock; *infundibuliformis*, in the buzzard, ducks, and poultry; *sturni*, in the starling; *passeris*, in the sparrow; and *hirundinis*, in the martin swallow.

One, viz.

T. Nodulosa, infests various species of fish.

nodulosa.

C. Head unarmed with hooks.

Of this section the following infest the mammalia, viz.

Dentata, sometimes said to be found in mankind; *mammali-phocæ*, in the great seal; *bassilaris*, in the mole; *pecunata*, in the hare and rabbit; *ovina*, in sheep; *equina* in the horse; and *suis*, in the Ethiopian hog.

The following are found in birds, viz.

Globifera, in the buzzard, lanner, and thrush; *per-avium*, *lata*, in the buzzard; *flagellum*, in the kite; *candelabraria*, in the Aluco owl; *crenata*, in the spotted wood-pecker; *lanceolata*, in the merganser and smew; *setigera*,

Species. *Intestina.* *gera*, and *anseris*, in the goose; *anatis*, in various species of duck; *lævis*, in the duck, &c.; *cuneata*, in various species; *alceæ*, in the auk; *tordæ*, in the razor-bill; *tardæ*, in the bustard; *linea* in partridges; and *maculata*, in the redwing.

One, viz.

bufonis. *Bufonis*, is found in the toad and salamander. The following infest fish, viz.

picium. *Anguillæ*, in the eel; *rugosa*, in the cod; *scorpii*, in the armed bullhead; *percæ*, in the sea perch; *erythrinæ*, in the Norway perch; *cernuæ*, in the ruffe; *solida* and *gasterostei* in the stickle-back; *siluri*, in the *silurus glanis*; *salmonis*, in the salmon; *frœlichii*, in the *salmo westmanni*; *rectangulum*, in the barbel; *torulosa*, in the cyprinus jeses, and *laticeps*, in the bream.

Gmelin, in his edition of the *Systema Naturæ*, enumerates 86 species of the *tœnia*.

³¹
Furia.

15. FURIA.

Body linear, equal, filiform, and ciliate on each side, with a single row of reflected prickles pressed close to the body.

infernalis There is only one species, viz. *infernalis*.

From the account given of this animal in the *Syst. Nat.* it appears to be a very formidable creature. It inhabits the extensive marshy plains of Bothnia; is about an inch long, and of a pale red or brown colour, generally with a black tip. It mounts up the sedges and shrubs, and being driven by the wind through the air, enters through the skin of men and horses in such parts as are exposed and situated obliquely; leaving a black mark where it had entered. It first excites a sensation like the prick of a needle, which is followed by violent itching and acute pain. An inflammation and commonly gangrene is the consequence, attended with fever, faintings and delirium, and frequently terminating in a short time in death, unless the worm is speedily extracted, which is a work of considerable difficulty. The part where the worm entered is to be scarified, and anointed with oil of birch, or covered with a poultice of curds or cheese.

³²
Gordius.

16. GORDIUS.

Body round, equal, filiform, and smooth. Body pale brown (or yellowish) with dark extremities. *Water hair-worm.*

aquaticus. This worm is about the thickness of a horse's hair, and when full grown, is ten or twelve inches in length. Its skin is somewhat glossy, and of a pale yellowish white, except the head and tail, which are black. It is common in our fresh waters, and particularly in such where the bottom is composed of soft clay, through which it passes as a fish does through water.

Its popular name arose from the idea that it was produced from the hair of horses and other animals that were accidentally dropped into the water; an idea that is yet prevalent among the lower class of people.

Its Linnæan name of *gordius* originated in the habit that it has of twisting itself into such peculiar contortions as to resemble a complicated gordian knot. In this state it often continues for a considerable time, and then slowly disengaging itself, extends its body to the full length. Sometimes it moves in the water with a

VOL. X. Part I.

tolerably quick undulative motion like that of a leech; and at other times its motions are the most slow and languid imaginable. When the water in which it swims happens to be dried up, it soon loses every appearance of life; the slender body shrivels, and it may be kept in this state a considerable time. But whenever it is put into water its body soon reassumes its former appearance; in less than half an hour it begins to move, and in a few minutes more it is as active and lively as ever. How long it may be preserved in this dried state without losing its life, or how often it might admit of being revived, has not been ascertained. When kept in a vessel of water, it will sometimes appear motionless and as if dead for several hours, and afterwards will resume its vigour, and seem as healthy as before.

It is a very remarkable circumstance, that its bite, which it sometimes inflicts on being taken out of the water, has been known to produce the complaint called a whitlow. This is mentioned by Linnæus as a popular opinion in Sweden, and it has since his time been confirmed by various other persons.

This *gordius* is sometimes found in the earth as well as in water, and particularly in gardens of a clayey soil after rain.

Besides this species four others are enumerated, viz.

Argillaceus, *filum*, *lacteus*, and *arenarius*; but it is probable that the first of these, which is said to pierce through clay, to give passage to water, is merely a variety of the aquaticus.

17. HIRUDO.

³³
Hirudo.

Body oblong, truncate at both ends, unarmed and cartilaginous, moving by dilating the head and tail, and contracting itself into an arch.

Elongated, of an olive black colour, with six yellow ferruginous lines above, and yellow spots below. *Medicinal leech.*—This species is generally two or three inches long, when lying in its natural state, though it is capable of very great dilatation. The body is composed of numerous annular wrinkles, which may be seen projecting, and by which the animal can expand or contract its body at pleasure. The head is smaller than the tail. This latter terminates in a circular muscle or sucker, which when applied to any substance easily adheres; probably by the animal's drawing up the middle, and thereby exhausting the air below. By means of the tail it fastens itself with ease and security, while it extends the other parts of its body in any direction; and it is so firmly fixed, that it can move about without any danger of being carried away by the current. When the animal is desirous of changing its place, it extends its body forwards, fixes its head in the same manner as it did its tail, which latter it then loosens, draws up, and then fastens near its head, so as to form a fresh point from which to continue its movements.

Its head is furnished with three teeth, of a substance resembling cartilage, which are so situated as to converge when the animal bites, and to leave a triangular mark on the skin. These teeth are so strong that by means of them the animal can pierce the skin of an ox or a horse, as well as that of a man; and through the holes which it forms, it sucks the blood. This appears to be done by contracting the muscles of its throat, so

X x

Species.
Intestina

as to make the blood rush through the vacuum formed above the wound, into the stomach of the leech. This stomach is a kind of membranaceous skin, divided into 24 small cells. If suffered to retain the blood which it has sucked, this is said to remain in the stomach of the animal for months together, almost without coagulating, and to afford support to the animal during the whole of that time. It appears to pass off through the pores of the skin by transpiration, the matter fixing on the surface of the body, and afterwards coming off in small filaments. Mr Bingley affirms in proof of this, that if a leech be immersed in oil (where it will keep alive for several days), and afterwards put into water, a slough will be seen to loosen from its skin, exactly of the shape of the animal.

It is viviparous, and produces only one at a time, which is commonly in the month of July. It inhabits clear running waters, but may be kept for a considerable time in vessels partly filled with water, which should be changed occasionally, when it becomes putrid. In general, if the number of leeches kept together is not great, the water need not be changed oftener than once a month in winter, and once every fortnight in summer; and we have known instances where several leeches have, when neglected, lived for several months in the same water. If, however, the number be large, they frequently die, which is thought to be owing to their fighting and killing each other.

34
Method of
applying
leeches.

When leeches are to be applied for the purpose of extracting blood from any part of the body, the most lively, and those of a moderate size, should be selected for that purpose; and they should be suffered to remain out of the water in a covered vessel for some time before they are applied. The best method of applying them is, to put them within a hollow glass tube, ground smooth at one end, open at both extremities, and bending so as to admit of its being applied to any part occasionally. The leech will commonly soon fix, but the skin to which it is to be applied should always be washed thoroughly clean, and should be freed from hair. If the animal is averse to fix, it may often be enticed to do so by rubbing the part of the skin with a little fresh cream, or new milk. When the leech has gorged itself with blood, it commonly drops off spontaneously; but if it should be too long in quitting its hold, it may be speedily made to do so by inserting a little salt, pepper, vinegar, or other acrid substance, between the margin of its head and the skin. As a leech, after it has been used for drawing blood, will not, for a long time, suck again, if suffered to retain the blood it has drawn, various methods have been contrived to evacuate the blood. The common method is, to sprinkle a little salt upon its mouth, which commonly makes it disgorge a great quantity of blood; but we are not certain whether more animals are not killed in this way than by suffering the blood to remain. The most effectual, and we believe the safest method of making them disgorge the blood is, to lay hold of them by the tail, and strip them between the fingers, after which they should be put into clean water.

The best method of conveying leeches to a distance is, to put them into a strong, wide-mouthed glass bottle, and to put with them a piece of sponge thoroughly wetted with water, tying a piece of bladder pricked with holes over the mouth of the bottle.

2

It is said that leeches, when kept in bottles, will become very restless just before a change of weather is about to take place. This may be the case, but from many observations which we have made, we believe that they afford very uncertain presages of the state of the atmosphere.

Species.
Intestina.

Elongated, of an olive brown colour, with an ochre-yellow marginal band. *Horse-leech.*

This is larger than the former; its skin is smooth and glossy; its back of a dusky colour, and the belly of a yellowish green; its body is depressed. It inhabits stagnant waters. It is to be carefully distinguished from the former species, as it will not answer the purposes of surgery.

Besides these two species, the following are described in the *Systema Naturæ*; viz. *indica*, *lineata*, **octoculata*, **stagnalis*, *complanata*, **viridis*, **heteroclyta*, **geometra*, *tesselata*, *marginata*, *grossa*, *hippoglossi*, **crenata*, **muricata*, and *branchiata*. In all 17 species.

18. LUMBRICUS.

35
Lumbricus.

Body round, annulate; generally with an elevated, fleshy belt near the head, and commonly rough, with minute concealed prickles, placed longitudinally, and furnished with a lateral aperture.

There are 16 species of this genus, viz.; **terrestris*, **marinus*, *vermicularis*, *variegatus*, *tubifex*, *lineatus*, *ciliatus*, *tubicola*, *echeiurus*, *thalassima*, *edulis*, **oxyarus*, *fragilis*, *armiger*, *corretus*, *sabellaria*.

Of these, the only one of which we shall make particular mention, is the *terrestris*, *common earth-worm*, or *dew-worm*. Body red, with eight rows of prickles.

This worm has neither bones, brains, eyes, nor feet. It has a number of breathing holes situated along its back, near each ring. Its heart is placed near the head, and may be observed to beat with a very distinct motion. The body is formed of small rings, furnished with a set of muscles that enable it to act in a sort of spiral direction; and by this means it is capable, in the most complete manner, of creeping on the earth, or penetrating into its substance. Mr Bingley explains the motion of these animals by that of a wire wound about a cylinder, where, when one end is drawn on and held fast, the other, upon being loosed, will immediately follow. These muscles enable the worm to contract or dilate its body with great force. The rings are each armed with small, stiff, sharp prickles, which the animal is able to open out or close upon its body; and from beneath the skin there is secreted a slimy matter, which, by lubricating the body, greatly facilitates its passage through the earth.

It is of consequence to point out the difference between this worm and the *ascaris lumbricoides*, or long round worm of the human intestines, described at page 338, as they have been supposed to be merely varieties of the same animal. The common earth-worm has its extremities much blunter than those of the *intestinal*; its mouth consists of a small, longitudinal fissure, situated on the under surface of a small rounded head, there being no appearance of the three vesicles so evident in the *ascaris*. On the under surface of the earth-worm there is a large semilunar fold of skin, into which the head retreats; but this is entirely wanting in the *ascaris*; the anus of the earth-worm opens at the very extremity.

36
Differences
between
the earth-
worm and
the *ascaris*
lumbricoides.

Species.
Intestina.

Species.
Intestinum.

tremity of the tail, and not as in the ascaris, at a considerable distance from the tail. The ascaris also wants the transverse rugæ which are so strongly marked in the earth-worm, as well as the broad yellowish band by which the body of the latter is surrounded.

The internal structure of these two species of worms is also extremely different. In the earth-worm, there is a large and complete stomach, consisting of two cavities; and the intestinal canal in the latter is likewise larger, and more formed into sacculi than the ascaris. The parts subservient to generation in these two species of worms differ very much from each other; in the ascaris there is a distinction of sex, the parts of generation being different in the male and in the female; in the common earth-worm the organs of generation are the same in each individual, as this worm is hermaphrodite. The appearance, too, of the organs of generation, is extremely different at first sight in the one species of animal and the other. There is an oval mass situated at the anterior extremity of the earth-worm, resembling a good deal the medullary matter of the brain*.

* *Bullie's Morbid Anatomy.*

Dew-worms, though in appearance a small and despicable link in the chain of nature, yet, if lost, might make a lamentable chasm. For, to say nothing of half the birds and some quadrupeds which are almost entirely supported by them, worms seem to be the great promoters of vegetation (which would proceed but ill without them) by boring, perforating, and loosening the soil, and rendering it pervious to rains and the fibres of plants, by drawing straws and stalks of leaves and twigs into it; and most of all, by throwing up such infinite numbers of lumps called worm-casts, which form a fine manure for grain and grass. Worms probably provide new soil for hills and slopes when the rain washes the earth away; and they affect slopes, probably to avoid being flooded.

Gardeners and farmers express their detestation of worms; the former, because they render their walks unsightly, and make them much work; and the latter, because they think worms eat their green corn. But these men would find, that the earth, without worms, would soon become cold, hard-bound, and void of fermentation, and consequently sterile; and besides, in favour of worms, it should be hinted that green corn, plants and flowers, are not so much injured by them as by many species of insects in their larva or grub-state, and by unnoticed myriads of those small shell-less snails called slugs, which silently and imperceptibly make amazing havock in the field and garden †.

† *Dingley's Animal Biography, vol. iii. p. 500.*

37
Sipunculus.

19. SIPUNCULUS.

Body round and elongated; mouth cylindrical at the end, and narrower than the body; aperture at the side of the body warty.

There are two species; viz. S. * *nudas* and *sacculus*.

* *nudus.*

Body covered with a close skin, and globular at the lower end. *Naked tube worm.*—This animal is about eight inches long, and nearly of a conical figure from head to tail, having the base usually about nine lines, and the other extremity about four lines in diameter. The broader part of the body is the head, and is furnished with a mouth, in which there is a tube made of

a strong membrane, and armed with three fleshy-pointed papillæ, about the size of a grain of millet. This trunk is at one end every where connected with the rim of the mouth, but is loose at the other end. It may be extended to the length of an inch, or entirely withdrawn at the pleasure of the animal, probably for the purpose of seizing its food, and carrying it to its mouth. When the tube is out of the mouth, the papillæ are on the outside, but they occupy the inside of the mouth when the tube is within. Hence the food laid hold of by the disengaged part of the trunk cannot escape; as the further the trunk is drawn back into the mouth, it is arrested by so many more papillæ, which like prongs are ready to detain it. At the distance of an inch and a half from the mouth there is an oblong aperture, surrounded with a prominent lip, and situated transversely.

The whole body of this animal is of a sallow white, inclining to a clay colour, and is adorned with deep streaks; some of which are longitudinal, and others circular. Sometimes this animal will extend itself to almost the length of a foot, while at other times it contracts into a very small volume, by enlarging the narrower portion of its body near the point, which is spherical.

It inhabits deep seas, from which it is never cast on the shore, but it sometimes enters the fishermen's nets along with their fish.

Body covered with a loose skin, and rounded at the lower end. Vid. fig. 9. *sacculus.*

Fig. 9.

This animal differs little from the former, except in the loose skin in which the animal is enclosed as in a bag. It inhabits the American and Indian seas.

38
Planaria.

20. PLANARIA.

Body gelatinous, flattish, with a double ventral pore; mouth terminal.

The animals comprehended under this genus nearly resemble the leeches, and like them live in fresh water. They are very numerous, but, as nothing remarkable is known respecting them, we shall merely enumerate their names.

A. *Without eyes.*

Stagnatus, nigra, brunea, ciliata, gulo, punctata, flaccida, rosea, angulata, rubra, viridis, operculata, subulata, quadrangularis, bicornis, grisea, fulva, viridata.

B. *Having a single eye.*

Glauca, lineata, nictitans.

C. *Having two eyes.*

Fusca, lactea, tonica, tentaculata, crenata, bellua, obscura, rostrata, atomata, cornuta, radiata, strigata, grossa, linearis, terrestris, tetragona, capitata, caudata, auriculata, filaris, lingua.

D. *Having three eyes.*

Gesserensis.

E. *Having four eyes.*

Marmorata, candida, truncata.

X x 2

Species.
Mollusca.F. *Having more than four eyes.*

Tremellaris.

There are in all forty-two species.

This Order comprehends twenty genera, and about 496 species.

SECT. II.

ORDER II. MOLLUSCA.

We have already, in the second part of the article ANATOMY, chap. viii. given a sufficient account of the general structure of the animals of this order, and of the several subdivisions of it, as given by Cuvier, to whose writings and those of La Marck, the lovers of natural history are chiefly indebted for the present state of our knowledge respecting those animals. Cuvier includes under the mollusca all those animals which inhabit shells, as well as those which are naked. The latter only can be considered here, and we shall chiefly confine ourselves to some of the more remarkable species.

39
Actinia.

21. ACTINIA.

Body oblong, cylindrical, fleshy, and contractile, fixed by the base; mouth terminal, expansile, surrounded with numerous tentacula, and without any other aperture.

This genus comprehends most of those extraordinary animals which have been described under the title of *animal flowers*, *sea-marygolds*, &c. an account of which has been already given under the article *ANIMAL-Flower*. We shall here therefore only enumerate the species, which are 23 in number; viz. *rufa*, * *crassicornis*, * *plumosa*, * *anemonoides*, *judaica*, * *effæta*, *coccinea*, *undata*, *viduata*, * *truncata*, *nodosa*, *spectabilis*, *digitata*, *gigantea*, *alba*, *viridis*, *priapus*, *candida*, *bicornis*, *vulva*, * *caryophyllus*, *iris*, *fiscella*, *pusilla*, * *cereus*, * *bellis*, * *gemmacea*, * *mesembryanthemum*, *sociata*, *aster*, *anemone*, *helianthus*, * *dianthus*, *calendula*, *doliolum*, * *maculata*.

40
Clava.

22. CLAVA.

Body fleshy, gregarious, club-shaped, and fixed by a round peduncle, having a single vertical aperture.

There is but one species; viz. *parasitica*; characterised by its having a whitish, pellucid peduncle, and an opaque red club that is covered with erect, conical, pellucid spines. It is found in the Baltic sea, upon sea weeds, shell-fish, and floating timber. It possesses the power of dilating and contracting the mouth.

41
Pedicellaria.

23. PEDICELLARIA.

Body soft, and seated on a rigid fixed peduncle, having a single aperture.

There are three species; viz. *P. globifera*, *triphylla*, and *tridens*, all which are found in the North seas, chiefly among the spines of echini.

42
Mammaria.

24. MAMMARIA.

Body smooth, and without rays, having a single aperture.

There are three species; viz. *M. mammilla*, *varia*, and *globulus*. Found also in the North seas and on the shores of Greenland.

Species.
Mollusca.

25. ASCIDIA.

43
Ascidia.

Body fixed, roundish, and appearing to issue from a sheath, having two apertures, generally placed near the upper extremity, one below the other.

There are about 35 species of *Ascidia*; viz. *papillosa*, *gelatinosa*, * *intestinalis*, *quadridentata*, * *rustica*, *echinata*, *mentula*, *venosa*, *prunum*, *conchilega*, *parallelogramma*, *virginica*, *canina*, *patula*, *aspera*, *scabra*, *orbicularis*, *corrugata*, *lapidiformis*, *complanata*, *tuberculom*, *villosa*, *clavata*, *pedunculata*, * *mammillaris*, *globularis*, *fusca*, *gelatina*, *crystallina*, *octodentata*, *patelliformis*, *pyura*, *aurantium*, *globularis*, *fasciculata*.

Of these we shall describe only two, the *papillosa*, and the *intestinalis*.

Body rough, and covered with scarlet tubercles.—*papillosa*. This animal is generally about three inches long, and something less than two broad; its shape is oval. On the upper part it is furnished with two mammillary protuberances, one of which is seated on the top of the body, and has an orifice in the form of a cross. The other is placed a little below the former, and has a triangular orifice opening transversely. The lips of either orifice are encompassed with several setaceous hairs, of a clay colour, and one line in length, but observing no regular order. The whole surface of the body is rough, being covered over with small knobs or oblong nipples of a scarlet colour. The extremity opposite to the organs, or the basis, is furnished with peduncles of various forms, by means of which this animal firmly adheres to rocks or other bodies, so that it cannot be forced from its situation without injuring the peduncles.

The skin, which is thick and hard like the hide of a quadruped, constitutes by far the greater part of the animal's bulk; and there is scarcely any thing distinguishable within, except a small part that commences a little below the orifice of the upper papilla, from which it proceeds downwards, and is inserted into the lower orifice, having the appearance of an intestine. From the appearance of this organ, it is supposed that the upper orifice is the mouth, and the lower the anus. This species is not used for food, though some of them are said to be eatable.

Body elongated, membranaceous, smooth, and whitish, appearing like the intestines of a quadruped.—*intestinalis*. If the membrane of which nearly the whole of this animal's body consists, be divided longitudinally, there appears another membranaceous canal descending from the upper organ, almost to the base, where it bends back, and proceeds towards the lower organ, into which it is inserted. This canal is commonly filled with a blackish fluid. These organs are sometimes strongly contracted, and at others as much relaxed. They do not appear, like those of the former species, to be able to draw in and throw out the water.

The animals belonging to this genus have the power of squirting out the water they receive, as if from a fountain; and it is probable that they derive their nourishment from the animalcula which the water contains.

Species.
Musca.

26. SALPA.

44
n.

Body long, floating, gelatinous, tubular, and open at each extremity, with an intestinal tube placed obliquely.

The outer covering of these animals has two openings, one very large, serving for the introduction of the water in which they live between their branchiæ, and the other smaller, which appears to be the anus. They have no head or feet. They are found in all our seas. Many of the species are remarkable for the regularity which they observe in their mode of swimming. They are gregarious, and one always follows at the tail of another, in such a manner as to touch each other, and to form two lines, one above the other, each individual of the upper line being supported by two of the lower.

The species are arranged under two subdivisions.

A. *Furnished with an appendage.*

This section contains four species; viz. maxima, pinnata, democratica, and mucronata.

B. *Having no terminal appendage.*

This section contains seven species; viz. punctata, confederata, fasciata, siphon, africana, solitaria, and polycratica.

45
ysia.

27. DAGYSIA.

Body loose, floating, angular, tubular, and open at each extremity.

There is only one species of this genus; viz. notata, characterized as having the body marked at one end with a brown spot. It is about three inches long, and one thick, and is found in the sea on the coasts of Spain. These animals adhere to each other by their sides, and in other respects very nearly resemble those of the last genus.

46
retra-

28. PTEROTRACHIA.

Body detached, gelatinous, with a moveable fin at the abdomen or tail; eyes two, placed within the head.

There are four species; viz. coronata, hyalina, pulmonata, and aculeata.

47
ria.

29. DERRIS.

Body cylindrical, composed of articulations; mouth terminal, feelers two.

There is only one species; viz. * sanguinea, which is found on the coast of Pembroke-shire.—This animal has a tapering body to a point behind, and is capable of great flexibility; it is covered with a transparent membranous coat, through which the internal parts are visible. The head is extended beyond the outer skin, and is less than the rest of the fore part of the body. The tentacula are white, and seated at the top of the head. The mouth consists of two lips, the upper one hooked and moveable, the lower one straight and fixed. It moves by an undulating motion of the whole body.

Species.
Molusca.

30. LIMAX.

48
Limax.

Body oblong, creeping, with a fleshy kind of shield above, and a longitudinal flat disk beneath; aperture placed on the right side within the shield; feelers four, situated above the mouth, with an eye at the tip of each of the larger ones.

This genus comprehends those animals which are commonly called slugs, or naked snails, which are well known to commit such ravages in our fields and gardens, especially in wet weather.

There are 15 species; viz. lævis, * ater, albus, * rufus, * flavus, * maximus, hyalinus, * agrestis, cinctus, marginatus, reticulatus, aureus, fuscus, tenellus, and * lanceolatus.

The most curious species of this genus seems to be *agrestis*. what has been called the *spinning slug*, which is a variety of the *limax agrestis*.—This animal is of a grayish white colour with a yellowish shield, and is commonly about three-fourths of an inch long. It inhabits woods and other shady places. The following account of it has been given by Mr Hoy, in the first volume of the Linnæan Transactions.

About the year 1789, Mr Hoy observed, in a plantation of Scotch firs, something hanging from one of the branches, which, as it seemed uncommon, he approached, and found it to be this animal. It was hanging by a single line or thread attached to its tail. This was, upwards, very fine; but near the animal it became thicker and broader, till at length it exactly corresponded with the tail. The slug was about four feet below the branch, and nearly at the same distance from the ground; which it gradually approached at the rate of an inch in about three minutes. This rate, though slow, is not so much so as might be expected, considering that the animal is not furnished with any particular receptacle, as in some insects, for the gelatinous liquid from which its silken lines are formed. The line by which it descended was drawn from the slimy exudation gradually secreted from the pores that covered its whole body. A great degree of exertion seemed necessary to produce a sufficient supply of the liquid, and to force this towards the tail. It alternately drew back its head, and turned it as far as possible, first to one side and then to the other, as if thereby to press its sides, and thus promote secretion. This motion of the head in an horizontal direction made the whole body turn round; by which the line that would have otherwise remained somewhat flat became round. This motion also, in addition to the weight of the animal, tended, no doubt, materially to lengthen the line.

In addition to Mr Hoy's account, Dr Latham observes, that the secretion from which the thread is formed, does not come from the back or sides of the animal, but from its under part. That it did not proceed from any orifice in the tail was evident, for in some instances the animal was suspended by the tip, and in others from the side full one-eighth of an inch from the tip. The flow of the viscous secretion towards the tail appeared to be excited by an undulating motion of the belly, similar to that of crawling.

After these animals have spun for some time, their spinning power seems to be for a while lost, but in

all

Species. all those on which experiments have been made, it has
Mollusca. been recovered again by keeping them for a few hours
among wet moss.

grees of elongation, and at whose extremity is situated
the head.

Species.
Mollusca.

31. LAPLYSIA.

49
Laplysia. Body creeping, covered with reflected membranes, with
a membranaceous shield on the back covering the
lungs; aperture placed on the right side; vent above
the extremity of the back; feelers four, resembling
ears. Vid. fig. 10.

Plate
CCLII.
fig. 10.

An animal of this genus has been called the sea-hare, a name which is derived from the ancients; and the animal to which it is given appears to have been known at a very early period, and perhaps on that account its history is obscured with many fabulous narrations.

Fishermen seem in all ages to have attributed some noxious properties to those marine animals which do not serve for the nourishment of man; and the writings of naturalists are still filled with the reports of these ignorant men respecting several productions of the sea, as the sea-nettle, star-fish, and in particular the sea-hare. These relations have been multiplied and prodigiously increased with respect to the marvellous, whenever the figure, the colour, or smell of the animal have any thing extraordinary or forbidding in them, as is the case with the sea-hare. Hence we find a long list of noxious and astonishing properties attributed to this animal. Not only are its flesh, and the water in which it has been steeped, of a poisonous nature, but even its very aspect is deadly. A woman who would wish to conceal her pregnancy, cannot resist the sight of a female sea-hare, which produces nausea and vomiting, and finally miscarriage, unless a male of the same species, dried and salted, is given her to eat; for it is one of the superstitious ideas entertained by the common people in most countries, that every noxious species of animal carries within itself a remedy for the ill effects which it may occasion. It happens, indeed, unfortunately for the present story, that in the sea-hare there is no distinction of sex. If these animals in Italy (for the above stories are taken from Pliny) are so deadly to mankind, it is quite otherwise in the Indian seas; for there it is man who is such a deadly foe to the sea-hare, that he cannot take it alive, since it is destroyed by his very touch!

These ridiculous fables respecting an innocent animal, are still believed by many people, and others as ridiculous have been added to them. Mr Barbut relates that a sailor happening to take a *laplysia* in the Mediterranean, it gave him such instantaneous and excruciating pain as to cause an inflammation, and the poor man lost his arm! and so sensible are the fishermen of the poisonous quality of the mucus which oozes from its body, that they will not on any account touch it.

In an excellent memoir on the *laplysia*, contained in vol. ii. of *Annales de Muséum National*, Cuvier gives the following general description of the animals composing the genus.

They bear a considerable resemblance to the slugs; their body is oval, flattened below, so as to form a long and straight foot, and swelling out above; more or less pointed behind, and diminishing a little before, so as to form a sort of neck, that is susceptible of various de-

beyond the borders of the disc that forms the foot. The other borders of this disc are contracted, so as to form a kind of pallisade, surrounding the sides and back part of the body. This fleshy wall is contracted and raised more or less, and is folded into numerous undulations at the pleasure of the animal, who can fold the one part over the other, or can cause them to separate, so as to give them all manner of shapes. Between the borders we perceive a part almost semicircular, attached only by the right side, entirely moveable like a fleshy cover, the border of which is flexible, and sometimes forms a sort of gutter, to conduct the water to the organs of breathing, which are in fact under this cover. At the posterior extremity of its attachment is the anus, and between the anterior extremity of the same attachment, and that which corresponds to the membranaceous border of the body on the right side, is a hole, through which are passed the eggs of the animal, and that peculiar liquor which has been regarded as poisonous. But besides this liquor, which is whitish, and is rarely voided, the animal produces another kind much more abundant, and of a very deep purple red.

The mouth is situated below the head lengthwise, and the anterior border of the head forms on each side a membranous production that is conical, compressed, capable of being more or less prolonged, and forms a tentaculum. Behind the head, further back, there is on each side another conical tentaculum, which the animal can elongate or shorten at pleasure, but which he cannot withdraw within the body, like the snail. The extremity of this is a little folded longitudinally into two parts, so as to resemble the external ear of a quadruped. Before the base of this organ is the eye, which seems nothing but a little black point.

The parts above described are common to all the *laplysiae*, but differ in the several species in proportion and colour.

In the last edition of the *Systema Naturæ*, only two species of *laplysia* are mentioned; viz. *depilans*, which appears to be the original sea-hare mentioned by Pliny, and which owes its trivial name to the belief that the fetid liquor which it exudes is capable of taking off the hair from any part which it touches; and *fasciata*. Besides these, Cuvier enumerates and figures three others, viz. *camelus*, *punctata*, and *alba*.

32. DORIS.

30
Doris.

Body creeping, oblong and flat beneath; placed below, on the fore-part; vent behind on the back, and surrounded by a fringe; feelers 2-4, seated on the upper part of the body in front, and retractile within their proper receptacles.

This genus is divided by Gmelin into two sections.

A. Having four tentacula.

Of this there are seven species; viz. *fasciculata*, *minima*, *radiata*, *pennata*, *peregrina*, *affinis*, and * *argo*.

B. Having two tentacula.

Of this section there are 17 species; viz. * *verruco-*

des. sa, clavigera, quadrilineata, papillosa, auriculata, lacini-
lata, cervina, coronata, tetraquetra, * bilamellata,
olivelata, muricata, pilosa, lævis, arborescens, frondosa,
and stellata.

In a long and interesting memoir by Cuvier on the genus *doris*, printed in the 4th vol. of *Annales de Muséum National*, that celebrated naturalist shows that only seven of the species enumerated by Gmelin (viz. *argo*, *stellata*, *bilamellata*, *lævis*, *olivelata*, *muricata*, and *pilosa*), really belong to this genus, and that the rest should be arranged under other genera.

Cuvier admits thirteen species, six of them new; and distributes them into two sections.

a. *Flat doris*,

Comprehending ten species; viz. *solea*, *scabra*, *maculosa*, *verrucosa*, *limbata*, *tuberculata*, *stellata*, *pilosa*, *tomentosa*, and *lævis*.

b. *Prismatic doris*.

Three species; viz. *lacera*, *atro-marginata*, and *pustulosa*.

We regret that our limits will not permit us to translate the valuable observations contained in this memoir, to which we refer the reader for the description of the above species, and of their general anatomical structure.

One of the most remarkable of the species is the *argo* or *sea argus*, which we shall here describe. The whole body of the argus is obliquely flat, or perpendicularly compressed; its thickness in the middle is six lines, whence growing gradually thinner, at the edge it is no more than half a line thick. It is three inches and five lines in length, and two inches broad. The back shines with a scarlet dye, and the belly is of an agreeable clay colour, and both are curiously marked with white and black spots. The whole substance of the body is coriaceous and solid, and if cut through the middle, appears everywhere tinged with a saffron colour. Round the circumference of the body it is pliant, whence, at the animal's pleasure, it is formed into various folds and plaits. The head, which in all other animals is easily known by the peculiarity of its structure, in the argus is not determinable when its back is turned to the spectator, for the oval shape of the body, of nearly the same diameter throughout the circumference, makes no distinction of head. The tentacula too, which appear toward each extremity, are so much alike in this situation, as not to serve for distinguishing the head; but if the animal be turned, it will appear that the head is situated in that part from which the tapered tentacula rise. One half of these tentacula is white, and sunk into small round cavities, formed to the depth of two lines in the substance of the head. Their apex is prominent from the cavity, and is every where marked with black dots, which are supposed to be so many eyes, and afforded the reason for denominating this animal *argus*.

If the tentacula are touched, they are immediately withdrawn entirely within their cavities. On the upper part of the head is a mammillary prominence, situated near the belly, at about half an inch from the edge, and in the middle is seen a small oval aperture, which is the mouth of the argus.

One of the most remarkable parts of the animal,

and that which distinguishes it from all others, remains to be described.

On that part of the back which is opposite to the head, four lines distant from the border, is an oval aperture eight lines in length, and five broad. From the middle of this hole arises a fleshy trunk of a whitish colour, four lines long, one and a half broad, which divides into two larger branches, the right hand one subdivided into eight, the left into six lesser branches, which at length end in small slender twigs. Besides these, another large branch arising from the middle of the first trunk, runs off towards the head. On every one of the branches and twigs there are many black spots discernible by the naked eye, which contribute not a little to the beauty of this blooming part; but whether those punctures were hollow, has not been ascertained, even with the assistance of the microscope; though they are probably so many open mouths of vessels and breathing points. While the argus remains in the sea-water, it keeps this wonderful assemblage of lungs expanded; when out of the water, and touched with the finger, it contracts it into the form of a crown; and if the handling and irritation be continued for any time, it conceals the lungs entirely within the oval aperture, which is also then contracted into a narrower compass. Being put again into salt water, the aperture soon enlarges, and the branches of the lungs concealed within gradually push out again, lengthen, and expand.

33. TETHIS.

51
Tethis.

Body detached, rather oblong, fleshy, and without peduncles, mouth with a terminal cylindrical proboscis, under an expanded membrane or lip; apertures two, on the left side of the neck.

There are only two species; viz. *leporina*, and *simbria*, the latter of which is a very elegant looking animal, about six inches long, with a white body, having a fringed border, variegated with black and clay colour, and in some places glittering with gold-coloured spots. It is found in the Adriatic.

34. HOLOTHURIA.

52
Holothuria.

Body detached, cylindrical, thick, and open at the extremity; mouth surrounded by fleshy branched tentacula.

There are 23 species of this genus, viz. *elegans*, *frondosa*, *phantapus*, *tremula*, *physalia*, *thalia*, *caudata*, *denudata*, * *pentactis*, *papillosa*, *spallanzani*, *priapus*, *squamata*, *penicillus*, *fusus*, *inhærens*, *lævis*, *minuta*, *forcipata*, *zonaria*, *vittata*, *maxima*, and *impatiens*.

Of these we shall describe the *holothuria tremula*, which has the following specific character.

Upper surface covered with numerous conical papillæ; lower with cylindrical ones; tentacula fasciculate, (fig. 11.)—This species commonly measures eight inches in length when dead; but alive it extends itself to more than a foot, or contracts its body into a ball. Its figure is cylindrical, the diameter of which is every way equal to an inch and a few lines. The back of a dark brown, proudly bears a variety of fleshy pyramid-like nipples, of a dark colour likewise at their basis, but white at their apex. They are observed to be of

Species.
Mollusca.

two different sizes; the larger occupy the length of the back, in number 14 on each side, at the distance of six lines from each other, when the holothuria is contracted; but the intervening space is fully eight lines when the animal is extended. Others, like these, are placed here and there promiscuously. The less are scattered in like manner, without order, in every part of the back. Out of them all exudes a whitish muci- lage, serving to lubricate the body. Hence all these nipples seem to be so many glands furnished with an excretory duct, the aperture of which is so minute as not to be discoverable by the help of a common glass. That they are, moreover, provided with various muscles, follows from hence, that the holothuria can raise and obliterate them at pleasure. While the larger papillae are quite erect, their axis, and the diameter of their base, measures three lines. The belly, or part opposite to the back, in the holothuria, is of a pale brown, and set all over with cylindrical tentacula, in such numbers, that the head of a pin could scarcely find room between them. Their diameter is not much above a line, and their length is that of four lines. They are of a shining whiteness, except the extremity, which is of a dusky dark colour, and shaped like a socket. By the help of these tentacula, the holothuria fixes its body at the bottom of the sea, so as not to be easily removed by tempests, which would otherwise happen very frequently, as this animal dwells near the shores, where the water scarcely rises to the height of a fathom. Now, if it adheres to other bodies by means of its ventral tentacula, their point must necessarily have the form of a socket, as the cuttle-fish, sea-urchins, and star-fish have theirs shaped, by which they lay hold of any other body.

From this situation of the holothuria at the bottom of the sea, which it also retains when kept in a vessel filled with sea water, it must be evident to any one, that we have not groundlessly determined which was its back, and which its belly, which otherwise in a cylindrical body would have been a difficult task. But as all animals uniformly walk or rest upon their bellies, and the holothuria has likewise that part of its body turned to the earth on which the cylindrical tentacula are to be seen, it is clear that part is the abdomen or belly of this animal. However, both the abdominal and dorsal tentacula are raised and obliterated at the animal's pleasure, from which it is reasonable to conclude, that they are furnished with elevating and depressing muscles, and particularly because all the foresaid tentacula disappear after the animal's death; and hence it farther appears, that many naturalists have given a representation of a dead holothuria, since they have assigned it no tentacula*.

* Barbut's
Genera
Vermium.

53
Terebella.

35. TEREBELLA.

Body oblong, creeping, naked, often inclosed in a tube, furnished with lateral fascicles or tufts and branchiæ; mouth placed before, furnished with lips, without teeth, and protruding a clavate proboscis; feelers numerous, ciliate, capillary, seated round the mouth.

There are 11 species, viz. *cirrata*, *lapidaria*, * *conchilega*, *complanata*, *carunculata*, *rostrata*, *flava*, *rubra*, *aphroditois*, *bicornis*, and *stellata*.

lapidaria. Of these the *terebella lapidaria*, or stone-piercer; cal-

led by the French *Pinceau de Mer*, the sea pencil, is thus described by Barbut. "From the midst of the hairs issues the head of this small animal, supported by a long neck, and putting forth two small branching horns. The mouth, which is round, is armed with small teeth, like those of the *echini marini*, with which it masticates its food. The hairs are very fine, soft as silk, and form a tuft, from the middle of which issues the neck, and then its head. The body is shaped like that of a worm, is very long, and terminates at one end in a point, which very much resembles the stick end of a painting brush. The small head of our *terebella* appears underneath, drawn back as in the snail. It walks or crawls by the help of five small feet, placed on each side of the large part of its body, at the rising of the tuft of hairs, and close to each other."

Species.
Mollusca.

54
Triton.

36. TRITON.

Body oblong; mouth with an involute spiral proboscis, having 12 tentacula, 6 on each side, divided nearly to the base, the hind ones being cheliferous.

There is only one species, viz. *littoreus*, found on the shores of Italy.

37. SEPIA.

55
Sepia.

Body fleshy, receiving the breast in a sheath, having a tubular aperture at its base; arms 8, beset with numerous warts or suckers; and besides, in most species, 2 pedunculated tentacula; head short; eyes large; mouth resembling a parrot's beak. *Cuttle-fish*.

Cuvier divides the genus *sepia* into two, which he calls *seiche*, comprehending most of the species enumerated by Linnæus under *sepia*, and *poispe*, comprising two species. The former have a sac, with a kind of fin on each side, and they contain towards the back a peculiar body of a friable or cartilaginous substance, transparent in the living animal, which is placed within the flesh, without adhering to it; and proceeding from one side to the other without any articulation. The head is round, and provided with two large moveable eyes, the organization of which is almost as perfect as that of the eyes of warm-blooded animals. The mouth is situated at the top of the head, and has two similar jaws, in form and substance resembling the beak of a parrot, and surrounded with eight conical tentacula, furnished with suckers, by means of which the animal fixes itself to the rocks or other substances, so firmly, that it is often easier to tear away one of these arms than to induce the animal to quit its hold. The two others are very long, and have no suckers except at their extremity. These last seem to serve the animal for anchors to hold by.

Just before the neck there is a sort of funnel, which closes up the entrance of a sac, and seems to be the anus. These animals have internally a liver, a muscular gizzard, a cœcum, and a short intestinal canal. The circulation in these animals is carried on by very singular organs; there is a heart placed at the bottom of a sac, by which the blood is distributed to every part of the body, by means of arteries, and to which it is returned by veins, through a large *vena cava*, which divides itself for the purpose of conveying the blood to

other two hearts, one on each side, which distribute it to the gills, from whence it is passed to the first heart. The female produces eggs that are arranged in the form of a bunch of grapes.

These animals, when they perceive the approach of danger, emit a quantity of inky fluid, furnished by a particular vessel, and by thus obscuring the water, render their escape more easy, while from the bitterness of this liquid their foe is induced to give over the pursuit. There seems little doubt that the opinion of Swammerdam, that this liquor furnishes the Indian or China ink, is just; for if this ink be dissolved in water, in any considerable quantity, it very soon acquires a very high degree of putridity, which seems to prove that it is formed of some animal substance; and none seems better calculated for the purpose than this black liquor.

The second genus of Cuvier differs from the sepia, properly so called, in wanting the solid bony substance on the back, and the two long arms; but the eight tentacula are much longer in the individuals of this genus than in those of the sepia.

The male cuttle-fish always accompanies the female; and when she is attacked, he braves every danger, and will attempt her rescue at the hazard of his own life; but as soon as the female observes her partner to be wounded, she immediately makes off. When dragged out of the water, these animals are said to utter a sound like the grunting of a hog.

The hard substance, or bone as it is called, in the back of the cuttle-fish, when dried and powdered, is employed to form moulds, in which silversmiths cast small articles, such as spoons, rings, &c.; and it forms the useful article of stationary called *ponce*.

In the *Systema Naturæ* there are described eight species of sepia, viz. * octopus, * officinalis, unguiculata, hexapus, * media, * loligo, * sepiola, and tunicata.

iii. The officinalis was in great esteem among the ancients as an article of food, and is still used by the Italians.

i. The sepia octopus, or eight-armed cuttle-fish, which inhabits the seas of warm climates, is a most formidable animal, being sometimes of such a size as to measure 12 feet across its centre, and to have each of its arms between 40 and 50 feet long. It is said that he will sometimes throw these arms over a boat or canoe, which he would infallibly drag to the bottom, with those who are in it; did not the Indians, who are aware of this danger, carry with them a hatchet to cut off the arms.

38. CLIO.

Body naked, free, and floating, furnished with a fin on each side; head distinct, and having gills at the surface of the fins.

The above character of clio is that of Cuvier, who has written an able account of this and two other genera of his new order of mollusca, which he calls *pteropoda*, or *mollusca pinnata*, in the 4th vol. of *Ann. de Mus. Nat.*

Gmelin enumerates six species of clio, viz. caudata, pyramidata, retusa, borealis, helicina, and limacina.

39. ONCHIDIUM.

liam. Body oblong, creeping, flat beneath; mouth anterior; VOL. X. Part I. †

feelers two, above the mouth; arms two, at the sides of the head; vent behind, and inferior.

Species. Mollusca.

Species two, viz. typhæ, described by Dr Buchanan, 5th vol. Lin. Trans.; and peronii, described by Cuvier, *Ann. de Mus. Nat.*

40. LOBARIA.

58 Lobaria.

Body lobate, convex above, flat below.

One species, viz. quadriloba, having a tail with four lobes; and found in the north seas.

41. LERNÆA.

59 Lernæa.

Body oblong, somewhat cylindrical, naked; tentacula or arms, two or three on each side and round, by which it affixes itself; ovaries two, projecting like tails from the lower extremity.

There are 15 species, viz. branchialis, * cyprinacea, * salmonea, * asellina, * huchonis, clavata, unciata, gobina, radiata, nodosa, cornuta, pectoralis, lotæ, cyclopterina, and pinnarum.

42. SCYLLÆA.

60 Scyllæa.

Body compressed and grooved on the back; mouth consisting of a terminal toothless aperture; tentacula, three on each side, placed beneath.

Two species, viz. pelagica and gomphodensis.

43. APHRODITA.

61 Aphrodita.

Body creeping, oblong, covered with scales, and furnished with numerous bristly fasciculate feet, on each side; mouth terminal, cylindrical, retractile; feelers two, setaceous, annulate; eyes four.

There are 9 species, viz. * aculeata, * scabra, * squamata, imbricata, plana, * lepidota, cirrosa, violacea, and longa.

The aculeate aphrodite, by some called the *sea mouse*, *aculeata*, is of an oval form, grows to the length of four or five inches; the belly is covered with a naked skin and somewhat prominent in the middle: its substance is somewhat firm. It is clothed with hairy filaments, which are short on the middle of the back, but longer at the sides; they are all somewhat rigid and firm; those on the back stand erect, like the quills of a porcupine; those on the sides lie flat, and are of a great variety of colours; a beautiful blue and lively green are very distinct in them, but a golden yellow is most predominant; on the back they are darker, and in many places of a grayish brown. It dwells in the European ocean, living upon shell-fish, and has 32 fasciculated projectors, resembling feet, on each side.

44. AMPHITRITE.

62 Amphitrite.

Body projecting from a tube and annulate; peduncles or feet small, numerous; feelers two, approximate, feathered; eyes none.

There are seven species, viz. reniformis, penicillus, Y y ventilabrum,

Species. *ventilabrum, auricoma, cristata, chrysocephala, and plumosa.*

63

Spio.

45. SPPIO.

Body projecting from a tube, jointed, and furnished with dorsal fibres; peduncles rough, with bristles, and placed towards the back; feelers two, long, simple; eyes two, oblong.

There are two species, viz. *seticornis* and *filicornis*.

64

Nereis.

46. NEREIS.

Body long, creeping, with numerous lateral peduncles on each side; feelers simple, rarely none; eyes two or four, rarely none.

The species are 29 in number, and are divided into three sections.

A. Mouth furnished with a claw;

Containing *versicolor, *noctiluca, fimbriata, armillaris, mollis, *delagica, tubicola, norwegica, pinnata, corniculata, pusilla, incisa, and aphroditoides.*

B. Mouth furnished with a proboscis;

Containing **cærulea, *viridis, maculata, crassa, stellifera, punctata, alba, flava, longa, prismatica, bifrons, cæca, ebranchiata, lamelligera, and ciliata.*

C. Mouth furnished with a tube;

Containing one species, viz. *prolifera*.

One of the most remarkable of these species is the *noctiluca*, of which we shall here give a short account.

noctiluca. Body blue green, with 23 segments, so small as to be scarcely visible to the naked eye.—This is one of those phosphorescent animals that illuminate the ocean in the dark. Their numbers and wonderful agility, added to their shining quality, do not a little contribute to these illuminations of the sea; for myriads of these animalcula are contained in a small cup of sea water. Innumerable quantities of them lodge in the cavities of the scales of fishes; and to them, probably, the fishes owe their noctilucous quality. "I have observed with great attention (says Barbut) a fish just caught out of the sea, whose body was almost covered with them; and have examined them in the dark: they twist and curl themselves with amazing agility, but soon retire out of our contracted sight; probably their glittering dazzling the eye, and their extreme minuteness eluding our researches. It is to be observed, that when the unctuous moisture which covers the scales of fishes is exhausted by the air, these animals are not to be seen, nor are the fishes then noctilucous, that matter being perhaps their nourishment when living, as they themselves afford food to many marine animals. They do not shine in the day-time, because the solar rays are too powerful for their light, however aggregate, or immense their number."

65

Nais.

47. NAIS.

Body creeping, long, linear, depressed, and pellucid; peduncles, with small bristles on each side; no tentacula; eyes two or none.

There are 10 species, viz. *vermicularis, *serpentina, *proboscidea, elinguis, *digitata, barbata, cæca, littoralis, marina, and quadricuspidata.*

Species. Mollusca.

48. PNYSSOPHORA.

Body gelatinous, pendent from an aerial vesicle, with gelatinous sessile members at the sides; numerous tentacula beneath.

There are three species, viz. *hydrostatica, rosacea, and filiformis.*

66 Physocphora.

49. MEDUSA.

Body gelatinous, orbicular, and generally flat underneath; mouth central, beneath.

These animals have been denominated *sea nettles*, from the opinion that the larger species, when touched, excite a tingling sensation, and slight redness of the skin. They are supposed to form the chief food of the cetaceous fish; and many of them shine with great brilliancy in the water. The form of their body, while at rest, is that of the segment of a sphere, of which the convex surface is smooth, and the flat part provided with several tentacula. The body is transparent, and so gelatinous, that it is reduced almost to nothing, by evaporation, when left dry upon the shore. Several coloured lines may be seen within; but there is nothing which gives marks of a circulation going on. The lines, indeed, towards the borders are more numerous, but they seem to be appendages of the alimentary cavity. These animals swim very well, and appear to perform that motion by rendering their body alternately more or less convex; and thus striking the water. When left upon the shore, they lie motionless, and look like large flat cakes of jelly.

67 Medusa.

The species are distributed into two sections.

A. Body with ciliated ribs.

This contains four species, viz. *infundibulum, pileus, cucumis, and ovum.*

B. Body smooth.

This contains 40 species, viz. *porpita, *cruciata, hysocella, *squorea, *aurita, capillata, *pilearis, marsupialis, hemispherica, pelagica, noctiluca, *fusca, *purpura, *tuberculata, *undulata, *lanulata, nuda, velleia, spirans, pulmo, tyrrhena, tubercularis, utriculus, caravella, umbella, dimorpha, campanula, digitata, frondosa, tetrastyla, octostyla, andromeda, corona, persea, cephea, proboscidalis, mollicina, pileata, crucigera, and unguiculata.*

50. LUCERNARIA.

Body gelatinous, wrinkled, branched; mouth placed beneath.

There are three species, viz. *quadricornis, phrygia, and auricula.*

68 Lucernaria.

51. ASTERIAS.

Body depressed, covered with a coriaceous crust; muricate, with tentacula, and grooved below; mouth central, and five-rayed.

69 Asterias.

These

These animals, which are usually called *star-fish*, or *sea-stars*, constitute one of the most numerous genera of the mollusca. They are very curious in their forms, but are almost all radiated, as stars are usually painted; and some of them, from the minuteness of their rays, make a very beautiful appearance.

By the coriaceous crust, with which they are covered, they are defended from the attacks of the smaller animals, that inhabit the seas in which they reside. Each of the rays has a great number of short, soft, and fleshy tubes, that serve for tentacula, and seem not only designed for taking prey, and aiding the motion of the animal; but also for enabling it to cling to the rocks, and thus resist the force of the waters. These tentacula have been found to exceed 1500 in a single animal; they are situated on the lower surface, and when the animal is laid on its back, they may be seen to be pushed out and withdrawn like the horns of snails. The rays enable them to swim, but they move very slowly. These rays are very brittle, and are easily broken off; but when this happens, their power of reproduction is so great, that they are speedily renewed. The mouth is armed with bony teeth, for breaking the shells of the small fish on which they feed; and from the mouth a canal proceeds through each of the rays, becoming narrower as it approaches the tip.

For preserving these animals, Mr Barbut advises that they be drowned in brandy or other spirits, taking care to keep the rays all the time extended. Then it is easy to draw out the entrails by the mouth with a pair of forceps; and after this is done, the animal may be dried.

There are 45 species distinguished, according as their circumference is more or less divided.

A. *Lunate*,

Comprehending four species, viz. *nobilis*, *pulvillus*, *militaris*, and *luna*.

B. *Stellate*,

Comprising 20 species, viz. *papposa*, *spongiosa*, **rubens*, **seposita*, *endeca*, *minuta*, **glacialis*, **clathrata*, *echinitis*, *reticulata*, *phrygiana*, *nodosa*, **violacea*, *sanguinolenta*, *perforata*, *araneica*, **equestris*, *lævigata*, *membranea*, *granularis*.

C. *Radiate*,

Comprising 20 species, viz. *rosea*, *pertusa*, **ophiura*, *aculeata*, *ciliaris*, **sphærolata*, **pentaphylla*, **varia*, **aculearis*, **hastata*, **fissa*, **nigra*, *tenella*, **pectinata*, *multiradiata*, **caput medusæ*, *curiali*, *aligætes*, *nigrita*, *tricolor*, and *fragilis*.

Many of these are extremely beautiful; but one of the most showy is the *caput medusæ*, or *arborescent star-fish*.

Having five rays, each subdivided, dichotomous; rays and disk granulate; mouth depressed (Vid. fig. 12).—This extremely singular species is occasionally met with in most seas; but it is not very common. It has five equidistant, thick, jointed rays, proceeding from the centre; and each of them is divided into two other smaller, and each of these is again subdivided in a similar manner; and this subdivision is carried, in the most beautiful and regular gradation, to a vast extent, so

that the extreme ramifications sometimes amount to several thousands. Mr Bingley speaks of a specimen that was three feet across, and had 512 extremities to each ray, making in all 2560. By this curious structure, the animal becomes, as it were, a living net, and is capable of entangling such creatures as are designed for its prey, by the sudden contraction of these numerous ramifications, by the intricacy of which they are prevented from escaping.

The colour of the living animal is a reddish or deep carnation; but when dead it is more of a gray colour. To preserve this curious animal whole and undamaged for cabinets, it should be taken far out at sea, and the fishermen should be careful not to break off any of the limbs, and to keep it as still as possible. It should be dried in the shade in some open place, as in the sun it is apt to melt away, and if too much in the shade, to become putrid.

This species is so valuable, that the fishermen at the Cape get from six to ten rix-dollars for a specimen.

52. ECHINUS.

70
Echinus.

Body roundish, covered with a bony crust, and generally furnished with moveable spines; mouth placed beneath, and commonly five-valved.

The animals of this genus are called *sea urchins* or *sea hedgehogs*, from the spines which grow on their external covering; they are also called *sea eggs*, probably from many of them being eatable. They are all inhabitants of the seas; and are so nearly alike in character, that a description of one species will serve to illustrate the whole family.

There are no less than 109 species, which are subdivided as follows.

A. *Vent vertical, and all the tentacula simple*.

a. *Globular or hemispherical*,

Containing 37 species, viz. **esculentus*, *sphæra*, *droebachiensis*, **miliaris*, *basteri*, *hæmisphericus*, *angulosus*, *excavatus*, *globulus*, *sphæroides*, *gratilla*, *lixula*, *saxatilis*, *fenestratus*, *subangularis*, **ovarius*, *diadema*, *calamaria*, *araneiformis*, *stellatus*, *radiatus*, *circinatus*, *cidaris*, *mamillatus*, *lucuntis*, *atratus*, **coronatus*, *asterizans*, *assulatus*, *sardicus*, *lammeus*, *variegatus*, *postulatus*, *granulatus*, *tesselatus*, *botryoides*, and *torcumaticus*.

b. *Shaped somewhat like a shield;*

Four species, viz. **sinuatus*, *semiglobosus*, *quinquilabiatum*, and *conoides*.

B. *Having the vent beneath and no tentacula at the mouth*.

a. *Base circular, with the vent in the circumference*,

Containing five species, viz. *alba-gabrus*, *depressus*, **vulgaris*, *quadrifasciatus*, and *sexfaciatus*.

b. *Base exactly circular;*

One species, viz. *subuculus*.

c. *Base oval;*

Three species, viz. *cyclostomus*, *semilunaris*, and *seniformis*.

Y y 2

d. *Base*

Species.
Mollusca.

d. *Base oval and acute; vent opposite the mouth;*
Six species, viz. * *scutatus*, *ovatus*, * *pustulosus*,
quadriradiatus, *minor*, and *dubius*.

e. *Base irregular, with five expanded petal-shaped marks on the surface.*

1. *Margin with angular sinuosities;*

Two species, viz. *rosaceus* and *attus*.

2. *Ovate; margin entire;*

Two species, viz. *oviformis* and *orbiculatus*.

f. *Flat on both sides, with petal-shaped avenues; mouth central, flat, and toothed; crown with four pores.*

1. *Having a sinuated margin and perforated surface;*

Seven species, viz. *biforis*, *pentaporus*, *hexaporus*,
emarginatus, *auritus*, *inauritus*, and *tetraporus*.

2. *Having a sinuated margin and entire surface;*

Five species, viz. * *laganum*, *subrotundus*, *reticulatus*,
orbicularis, and *gorallatus*.

3. *Having a toothed margin;*

Three species, viz. *decadactylus*, *octadactylus*, *orbiculus*.

g. *With ten avenues on the crown; rays straight, biporous, and stellate; mouth and vent near each other in the middle of the base;*

13 species, viz. *nucleus*, *centralis*, *ervum*, *craniolaris*,
turcius, *vicia*, *ovulum*, *lathyrus*, *equinus*, *minutus*,
falca, *inaequalis*, *raninus*, and *bufonius*.

C. *Vent lateral, with pencilled tentacula at the mouth.*

a. *Circular; mouth central, vent square;*

One species, viz. *placenta*.

b. *Heart-shaped, with the crown grooved;*

Two species, viz. *cor anguinum* and *lacunosus*.

c. *Heart-shaped, with the crown not grooved;*

Eight species, viz. *radiatus*, *purpureus*, *pusillus*,
complanatus, * *subglobulus*, *ananchitis*, *bicordatus*, and
carinatus.

c. *Ovate, with grooved avenues;*

One species, viz. *spatagus*.

d. *Ovate, with the avenues not grooved;*

Eight species, viz. *brissoides*, *teres*, *oliva*, *amygdala*,
ovalis, *pyriformis*, *lapiscaneri*, and *patellaris*.

Many of the above have hitherto been found only in a fossil state.

* *esculentus*.
Fig. 13.

Subglobular, with 10 avenues of pores; and the intermediate spines, covered with small tubercles, supporting the spines (fig. 13.).—This animal, which lodges in cavities of rocks, just within low water mark, on most of the British coasts, is nearly of a globular shape, having its shell marked into ten partitions or divisions, not much unlike those of an orange. The mouth is situated in the lower part, and armed with five strong and sharpened teeth. The stomach and intestines, which are of consi-

derable length, are disposed in a somewhat circular form; and the whole body is supported entirely by a set of upright bones or columns. Species, Zoophyta.

On the right side of the shell is a prodigious number of sharp moveable spines, of a dull white and greenish colour, curiously articulated, like ball and socket, with tubercles on the surface, and connected by strong filaments to the skin or epidermis, with which the shell is covered. The spines are the instruments by which the animal conveys itself at pleasure from one place to another; and by means of these it is enabled to move at the bottom of the water with great swiftness. It generally employs those about the mouth for this purpose, keeping that opening downwards; but it is also asserted to have the power of moving forwards, by turning on itself like a wheel. When any thing alarms these animals, they immediately move all their spines towards it, and wait an attack, as an army of pikemen would with their weapons. The number of muscles, fibres, and other apparatus necessary to the proper management of these must be very great, and are exceedingly wonderful. So tenacious are the sea-urchins of the vital principle, that on opening one of them, it is no uncommon circumstance to observe the several parts of the broken shell, move off in different directions.

Between the spines, and disposed in a continued longitudinal series on the several divisions or regions of the shell, are an infinite number of very small knobs, communicating with an equal number of tentacula placed above them. These are the instruments by which the creature fixes itself to any object, and stops its motion. They are possessed of a very high degree of contractile power, and are furnished at the extremities with an expansile part, which may be supposed to operate as a sphincter, or as the tail of a leech, in fastening the animal securely to rocks and other substances to which they choose to adhere.

The shell of this animal, when deprived of the spines, which easily fall off in drying, is of a pale reddish tinge, and the tubercles on which the spines are fixed, appear like so many pearly protuberances on the surface.

At Marseilles, and in some other towns on the continent, this species is exposed for sale in the markets, as oysters are with us, and is eaten boiled like an egg. It forms an article of food among the lower class on the sea coasts of many parts of this country; but does not seem to have made its way to the tables of the great.

This order of Mollusca contains 32 genera, and about 433 species.

ORDER IV. ZOOPHYTA.

THE creatures ranked under this order seem to hold a middle rank between animals and vegetables. Most of them are, like the latter, fixed by a root to a certain spot, from which they never move, and where they sprout and grow; many of them propagate, like plants, by buds, or slips; and some of them appear only to be entitled to rank as animal bodies by their possessing a degree of irritability a little superior to the *sensitive plant*. Few of them enjoy the faculty of locomotion, though the agility with which they seize their prey, and the instinct which directs them in search of it, shew them to be really animal bodies.

⁷¹
Species.
zoophyta. The coral reefs that surround many islands, particularly those in the Indian Archipelago, and round New Holland, are formed by various tribes of these animals, especially by those of the five first genera. M. Peron observes, that the animals form these corals with such rapidity, that enormous masses of them very speedily appear, where there was scarcely any mark of such reefs before.

The principal works that treat of the Zoophyta are those of Ellis, Solander, Pallas, and Dr Shaw's "Naturalist's Miscellany."

53. TUBIPORA.

Animal probably a nereis; coral, consisting of erect, hollow, cylindrical, parallel, aggregate tubes.

There are 10 species, viz. musica, catenulata, * serpens, fascicularis, ramosa, pennata, penicillata, flabellaris, stellata, and strues.

54. MADREPORA.

Animal resembling a medusa; coral with lamellate star-shaped cavities.

There are 118 species, which are distributed into five subdivisions, viz.

A. Composed of a single star,

Containing six species, viz. * verrucaria, turbinata, * porpita, fungitis, patella, and eyathus.

B. With numerous separate stars, and continued numerous gills.

14 species, viz. pileus, cristata, lactuca, ficoides, acerosa, lichen, agaricites, elephantatus, crustacea, incrustans, exesa, filograna, natans, and anthophyllum.

C. With numerous united stars.

There are 15 species, viz. labyrinthica, sinuosa, meandrites, areola, abdita, phrygia, repanda, ambigua, dædalia, gyrosa, clivosa, cerebrum, involuta, implicata, and cochlea.

D. Aggregate undivided, having distinct stars, and porous, tuberculous, prominent undulations.

There are 56 species, viz. favosa, cavata, bulliris, mnanas, byades, sidera, galaxea, pleiades, papillosa, radiata, latebrosa, polytonia, arenosa, interstincta, spongiosa, foliosa, porculata, stellulata, astroites, stellata, nodulosa, aeropora, cavernosa, punctata, calycularis, truncata, stellaris, organum, divergens, * musioalis, denticulata, faveolata, retepora, rotulosa, cespitosa, flexuosa, fascicularis, pectinata, rotularis, tubularis, mamillaris, patelloides, globularis, telum, perforata, vermicularis, * arachnoides, undulata, solida, monile, dædalia, monostriata, contiguatio, cristata, rus, and cuspidata.

E. Branched, having distinct stars, and porous tuberculous undulations.

There are 27 species, viz. porites, digitata, damicornis, verrucosa, muricata, fastigiata, ranica, oculata, virginea, rosea, hirtella, linulata, botryoides, granosa, proliferata, seriata, cactus, corymbosa, gammascens, problematica, spuria, infundibuliformis, angulosa, discoides, chalcidicum, concamerata, and rosacea.

55. MILLEPORA.

Animal an hydra or polype; coral mostly branched, and covered with cylindrical, turbinate pores.

There are 34 species, viz. alcornis, cærulea, aspera, solida, truncata, miniacea, * cervicornis, * skenci, pumila, compressa, * lichenoides, violacea, tubulifera, * fascialis, * foliacea, zeylanica, forniculosa, crustulenta, erosa, reticulata, * cellulosa, clathrata, reticulum, spongitis, coriacea, calcarea, * polymorpha, decussata, * alga, * pumicosa, * tubulosa, pinnata, * liliacea, and cardunculus.

56. CELLEPORA.

Animal an hydra or polype; coral somewhat membranaceous, and composed of round cells.

There are eight species, viz. ramulosa, spengites, * pumicosa, verrucosa, ciliata, hyalina, nitida, and annulata.

57. ISIS.

Animal growing in the form of a plant; stem stony and jointed; the joints longitudinally streaked, united by horny junctures and covered with a soft, porous cellular flesh or bark; the mouths of which are beset with oviparous polypes.

There are six species, viz. hippuris, dichotoma, ochracea, * entrocha, * asteria, and coccinea.

58. ANTIPATHES.

Animal growing in the form of a plant; stem expanded at the base, horny within, and beset with small spines; externally covered with a gelatinous flesh beset with numerous polypes bearing tubercles.

There are 13 species, viz. spiralis, ulex, subpinnata, myriophylla, allopecuroides, cupressus, oricalcea, dichotoma, clathrata, flabellum, pennacea, ericoides, and sceniculacea.

59. GORGONIA.

Animal growing in the form of a plant; leathery, corky, woody, horny, or bony; composed of glassy or stony fibres; streaked, tapering, dilated at the base, covered with a cellular flesh or bark, and becoming spongy and friable when dry; mouths covering the surface of the stem and polype-bearing.

There are 41 species, viz. lepadifera, verticillaris, * placomus, mollis, succinia, americana, exserta, patula, ceratophyta, juncea, flammea, embraculum, purpurea, sasappo, palma, radicata, suberosa, coralloides, elongata, scirpea, setacea, viminalis, muricata, * verrucosa, antipathes, * anceps, nobilis, crassa, pinnata, sanguinolenta, violacea, setosa, petechizans, pectinata, abietina, calyculata, briareus, ventalina, reticulum, clathrus, and * flabellum.

60. ALCYONIUM.

Animal generally growing in the form of a plant; stem fixed, fleshy, gelatinous, spongy or leathery, and beset with stellate cells bearing polypes.

Species.
Zoophyta.

There are 28 species, viz. *arboresum*, *exos*, * *digitatum*, *schlosseri*, *lyncurium*, * *borsa*, *cydonium*, * *ficus*, *gelatinosum*, *manusdiaboli*, * *arenosum*, *botryoides*, *massa*, *cranium*, *rubrum*, *mammillosum*, *ocellatum*, *tuberosum*, *gorgonoidea*, *asbestinum*, *album*, *papillosum*, * *conglomeratum*, * *ascidioides*, *synovium*, *vermiculare*, *stellatum*, and *corniculatum*.

79
Spongia.

61. SPONGIA.

Animal fixed, flexible, torpid, of various forms, composed either of reticulated fibres, or masses of small spines interwoven together, and clothed with a gelatinous flesh, full of small mouths on its surface, by which it absorbs and rejects water.

There are 49 species, viz. *ventilabrum*, *flabelliformis*, *infundibuliformis*, *fistularis*, *aculeata*, *tubulosa*, * *cornata*, *ciliata*, *cancellata*, *rubra*, *nigra*, *officinalis*, * *oculata*, *muricata*, *nodosa*, * *tomentosa*, *bacillaris*, *dichotoma*, * *stuposa*, * *cristata*, * *palmata*, *prolifera*, * *botryoides*, * *panicea*, *fulva*, *tubularia*, *fibrilloja*, *fasciculata*, *basta*, *lichenoides*, *papillaris*, *cavernosa*, *sinuosa*, *frondosa*, *agaricina*, *tupha*, *membranosa*, *compressa*, *penicillum*, *coalita*, *plana*, *cruciata*, *ossiformis*, *mauda*, *ficiformis*, * *lacustris*, *fluviatilis*, *friabilis*, and *canalium*.

The sponges consist of a ramified mass of capillary tubes, that were long supposed to be the production of a species of worms, which are often found within these cavities; an idea, however, which is now nearly exploded. Others have imagined them to be only vegetables; but that they are possessed of animality, appears evident from the circumstance of their pores, alternately contracting and dilating, and from their even shrinking in some degree from the touch, when examined in their native situations. Their structure properly enables them to absorb nourishment from the surrounding fluid.

These animals are certainly the most torpid of all the zoophytes. The individuals differ very much from each other, both in form and structure. Some of them, as the common sponge, are of no determinate figure; but others are cup-shaped, tubular, &c.

officinalis. Irregularly formed, porous, rough, lobed, and woolly. —The officinal sponge is elastic, and very full of holes; it grows into irregular lobes of a woolly consistence, and generally adheres, by a very broad base, to the rocks. It is chiefly found about the islands in the Mediterranean, where it forms a considerable article of commerce. A variety of small marine animals pierce and gnaw into its irregular winding cavities. These appear on the outside, by large holes raised higher than the rest. When it is cut perpendicularly, the interior parts are seen to consist of small tubes, which divide into branches as they appear on the surface. These tubes, which are composed of reticulated fibres, extend themselves every way, by this means increasing the surface of the sponge, and ending at the outside in an infinite number of small circular holes, which are the proper mouths of the animal. Each of these holes is surrounded by a few erect pointed fibres, that appear as if woven in the form of little spines. These tubes, with their ramifications, in the living state of the sponge, are clothed with a gelatinous substance, properly called the flesh of the animal. When the sponge is first taken it has a strong fishy smell, and the fishermen take great

care in making it perfectly clean, in order to prevent its growing putrid.

Species.
Zoophyta.62. FLUSTRA, *Sea Mat-Weed*, or *Horn-Wrack*.80
Flustra.

Animal a polype, proceeding from porous cells; stem fixed, foliaceous, membranaceous, composed of numerous rows of cells, united together, and woven like a mat.

There are about 18 species, viz. * *foliacea*, * *truncata*, * *pilosa*, * *chartacea*, * *carbacea*, *bombycina*, *verticillata*, * *dentata*, * *bullata*, *tomentosa*, *denticulata*, *tubulosa*, *hispidata*, *frondiculosa*, *papyracea*, *hirta*, * *membranacea*, and *lineata*.

63. TUBULARIA.

81
Tubularia.

Stem tubular, simple or branched, fixed by the base; animal proceeding from the end of the tube, and having its head crested with tentacula.

There are 26 species, viz. *magnifica*, *cornucopiæ*, * *indivisa*, * *ramosa*, *ramea*, * *fistulosa*, *fragilis*, * *muscoidea*, *papyracea*, *penicillus*, *acetabulum*, *splachnea*, * *coryna*, * *affinis*, *fabricia*, *longicornis*, *multicornis*, *repens*, * *campanulata*, * *reptans*, *sultana*, *stellaris*, *simplex*, *spallanzani*, *membranacea*, * and *flabelliformis*.

Of these, by far the largest, and probably the most beautiful species, is the *magnifica*, which is thus characterised by Dr Shaw.

With a simple whitish tube, and very numerous tentacula, variegated with red and white. Fig. 14. *magnifica*.
Plate
CCLIII
fig. 14.

It is found in various parts of the coast of Jamaica, adhering to the rocks. It is very shy, and on being approached, instantly recedes within its elastic tube, which on a farther alarm also retires into the rock, and specimens can be procured only by breaking off such parts of the stone as contain them. These being put into tubs of sea water, may be kept for months in perfect preservation.

64. CORALLINA.

82
Corallina.

Animal growing in the form of a plant; stem fixed, with calcareous subdivided branches, mostly jointed.

There are 38 species, viz. *tridens*, *opuntia*, *monile*, *incrassata*, *tuna*, *nodulosa*, * *squamata*, *loricata*, *palmeta*, * *elongata*, *subulata*, *granifera*, * *officinalis*, *pennata*, * *rubens*, * *crustata*, * *spermopheros*, * *corniculata*, *fragilissima*, *fruticulosa*, *indurata*, *lichenoides*, *rugosa*, *marginata*, *cylindrica*, *oblongata*, *obtusata*, *lapidescens*, *barbata*, *rosarium*, *cuspidata*, *tribulus*, *flabellum*, *conglutinata*, *phœnix*, *peniculum*, *penicillum*, and *terrestris*.

65. SERTULARIA.

83
Sertularia.

Animal growing in the form of a plant, stem branched, producing polypes from cup-shaped denticles or minute cells.

There are 77 species, which are distributed into two sections.

A. *Stem horny, tubular, fixed by the base, beset with cup-shaped denticles, and furnished with vesicles or ovaries containing polypes, eggs, or the living young.*

* *Rosacea*, * *pamila*, * *operculata*, * *tamarisca*, * *abietina*.

Species. *etina*, *nigra, *fuscescens, obsoleta, pinus, cupressoides, *cupressina, *argentea, *rugosa, *halecina, *theja, *myriophyllum, hypoides, speciosa, *falcata, *pluma, *echinata, *antennina, *verticillata, *gelatinosa, *volubilis, *syringa, *cuscuta, *pustulosa, *frutescens, pinaster, pennatula, *filicula, quadridentata, spicata, *evansii, *muricata, secundaria, misinensis, racemosa, *uva, *lindigera, *geniculata, dichotoma, *spinosa, *pinnata, *setacea, polygonias, pennaria, *lichenastrum, cedrina, *imbricata, purpurea, articulata, filicina, and fruticans.

B. *Stems crustaceous, resembling stone, and composed of rows of cells; no vesicles, but instead of them small globules. Cellularia.*

*Bursaria, *loriculata, *fastigiata, *ovicularia, *neretina, *seruposa, pilosa, crista, placeosa, *reptans, parasitica, ciliata, *sburnea, *cornuta, *boricata, *anguina, coreoides, tulipifera, tabulum, *ternata, cirrata, and opontioides.

84
innotula.

66. PENNATULA, the *Sea-pen*.

Animal not fixed, of various shapes; supported by a bony part within; naked at the base; the upper part having generally lateral ramifications furnished with rows of tubular denticles, with radiate polypes from each tube.

There are 18 species, viz. *coccinea*, *grisea*, *phosphaea*, *pilosa*, *rubra*, *mirabilis*, *sagitta*, *antennina*, *stellifera*, *phalloides*, *arundinacea*, *sciopia*, *juncea*, *grandis*, *argentea*, *encrinus*, *cynomorium*, and *reniformis*.

85
ydra.

67. HYDRA, the *Polype*.

Animal fixing itself by the base; linear, gelatinous, naked, contractile, and furnished with setaceous tentacula; inhabiting fresh waters, and producing its deciduous offspring from its sides. Fig. 15.

ig. 15.

These animals are among the most curious productions of nature, chiefly as exhibiting the most surprising example of diffused vitality. Though not so formidable as the hydra destroyed by Hercules, they are rendered equally prolific by being cut in pieces.

There are about five species, viz. *viridis*, **fusca*, **grisea*, *gelatinosa*, and *pallens*.

The three first species are those on which the greatest number of experiments have been made; and their shapes are so various, that it is by no means easy to describe them. They are generally found in ditches. Whoever has carefully examined these when the sun is very powerful, will find many little transparent lumps of the appearance of jelly, and size of a pea, and flatted upon one side. The same kind of substances are likewise to be met with on the under side of the leaves of plants that grow in such places. These are the polypes in a quiescent state and apparently inanimate. They are generally fixed by one end to some solid substance, with a large opening, which is the mouth, at the other, having several arms fixed round it, projecting as rays from the centre. They are slender, pellucid, and capable of contracting themselves into very small compass, or of extending to a considerable length. The arms are capable of the same contraction and expansion

as the body, and with these they lay hold of minute worms and insects, bringing them to the mouth, and swallowing them. The indigestible parts are again thrown out by the mouth.

Species.
Zoophyta.

The green polype was that first discovered by M. Trembley; and the first appearances of spontaneous motion were perceived in its arms, which it can contract, expand, and twist about in various directions. On the first appearance of danger they contract to such a degree, that they appear little longer than a grain of sand, of a fine green colour, the arms disappearing entirely. Soon afterwards, he found the *grisea*, and afterwards the *fusca*. The bodies of the *viridis* and *grisea* diminish almost insensibly from the anterior to the posterior extremity; but the *fusca* is for the most part of an equal size for two-thirds of its length from the anterior to the posterior extremities, from which it becomes abruptly smaller, and then continues of a regular size to the end. These three kinds have at least six, and at most twelve or thirteen arms. They can contract themselves till their bodies do not exceed one-fourth of an inch in length, and they can stop at any intermediate degree of expansion or contraction. They are of various sizes, from an inch to an inch and a half long. Their arms are seldom longer than their bodies, though some have them an inch, and some even eight inches long. The thickness of their bodies decreases as they extend themselves, and *vice versa*; and they may be made to contract themselves either by agitating the water in which they are contained, or by touching the animals themselves. When taken out of the water they all contract so much, that they appear only like a little lump of jelly. They can contract or expand one arm, or any number of arms, independent of the rest; and they can likewise bend their bodies or arms in all possible directions. They can also dilate or contract their bodies in various places, and sometimes appear thick set with folds, which, when carelessly viewed, appear like rings. Their progressive motion is performed by that power which they have of contracting and dilating their bodies. When about to move, they bend down their heads and arms, lay hold by means of them on some other substance to which they design to fasten themselves; then they loosen their tail, and draw it towards the head; then either fix it in that place, or stretching forward their head as before, repeat the same operation. They ascend or descend at pleasure in this manner upon aquatic plants, or upon the sides of the vessel in which they are kept; they sometimes hang by the tail from the surface of the water, or sometimes by one of the arms; and they can walk with ease upon the surface of the water. On examining the tail with a microscope, a small part of it will be found to be dry above the surface of the water; and, as it were in a little concave space, of which the tail forms the bottom; so that it seems to be suspended on the surface of the water on the same principle that a small pin or needle is made to swim. When a polype, therefore, means to pass from the sides of the glass to the surface of the water, it has only to put that part out of the water by which it is to be supported, and to give it time to dry, which it always does upon these occasions; and they attach themselves so firmly by the tail to aquatic plants, stones, &c. that they cannot be easily disengaged: they often further strengthen these attachments.

Species. attachments by means of one or two of their arms, Zoophyta. which serve as a kind of anchors for fixing them to the adjacent substances.

The stomach of the polype is a kind of bag or gut into which the mouth opens, and goes from the head to the tail. This, in a strong light, is visible to the naked eye, especially if the animal be placed between the eye and a candle; for these animals are quite transparent whatever their colour may be: the stomach, however, appears to more advantage through a powerful magnifier. M. Trembley, by cutting one of these animals transversely into three parts, satisfied himself that they were perforated throughout. Each piece immediately contracted itself, and the perforation was very visible through a microscope. The skin which encloses the stomach is that of the polype itself; so that the whole animal, properly speaking, consists only of one skin, in the form of a tube, and open at both ends. No vessels of any kind are to be distinguished.

The mouth is situated at the anterior end in the middle between the shooting forth of the arms, and assumes different appearances according to circumstances; being sometimes lengthened out in the form of a nipple, at others appearing truncated; sometimes the aperture is quite closed, at others there is a hollow; though at all times a small aperture may be discovered by a powerful magnifier.

The skin of a polype, when examined with a microscope, appears like shagreen, or as if covered with little grains, more or less separated from each other, according to the degree of contraction of the body. If the lips of a polype be cut transversely, and placed so that the cut part of the skin may be directly before the microscope, the skin throughout its whole thickness will be found to consist of an infinite number of grains, and the interior part is found to be more shagreened than the exterior one; but they are not strongly united to each other, and may be separated without much trouble. They even separate of themselves, though in no great numbers, in the most healthy animals of this kind; for where they are observed to separate in large quantities, it is a symptom of a very dangerous disorder. In the progress of this disorder, the surface of the polype becomes gradually more and more rough and unequal, and no longer well defined or terminated as before. The grains fall off on all sides, the body and arms contract and dilate, and assume a white shining colour; and at last the whole dissolves into a heap of grains, which is more particularly observed in the green polype. By a careful examination we find, that the skin of the polype is entirely composed of grains, cemented by means of a kind of gummy substance; but it is to the grains entirely that the polype owes its colour. The structure of the arms is analogous to that of the body; and they appear shagreened, when examined by the microscope, whether they be in a state of contraction or expansion; but, if very much contracted, they appear more shagreened than the body, though almost quite smooth when in their utmost state of extension. In the green polype the appearance of the arms is continually varying; and these variations are more sensible towards the extremity of the arm than at its origin, but more scattered in the parts further on. The extremity is often terminated by a knob, the hairs

of which cannot be observed without a powerful magnifier. They have a remarkable inclination for turning towards the light, so that if that part of the glass, on which they are, be turned from the light, they will quickly remove to the other. Species. Zoophyta.

That species named the *fusca* has the longest arms, *fusca*. and makes use of the most curious manœuvres to seize its prey. They are best viewed in a glass seven or eight inches deep, when their arms commonly hang down to the bottom. When this or any other kind is hungry, it spreads its arm in a kind of circle to a considerable extent, inclosing in this, as in a net, every insect which has the misfortune to come within the circumference. While the animal is contracted by seizing its prey, the arms are observed to swell like the muscles of the human body when in action. Though no appearance of eyes can be observed in the polype, they certainly have some knowledge of the approach of their prey, and shew the greatest attention to it as soon as it comes near them. It seizes a worm the moment it is touched by one of the arms; and in conveying it to the mouth, it frequently twists the arm into a spiral like a cork-screw, by which means the insect is brought to the mouth in a much shorter time than otherwise it would be; and so soon are the insects on which the polypes feed killed by them, that M. Fontana thinks they must contain the most powerful kind of poison; for the lips scarce touch the animal when it expires, though there cannot be any wound perceived on it when dead. The worm, when swallowed, appears sometimes single, sometimes double, according to circumstances. When full, the polype contracts itself, hangs down as in a kind of stupor, but extends again in proportion as the food is digested, and the excrementitious part is discharged. The bodies of the insects, when swallowed, are first macerated in the stomach, then reduced into fragments, and driven backwards and forwards from one end of the stomach to the other, and even into the arms, which, as well as the other parts of this remarkable creature, are a kind of hollow guts or stomachs. In order to observe this motion, it is best to feed the polypes with such food as will give a lively colour; such, for instance, as those worms which are furnished with a red juice. Some bits of a small black snail being given to the polype, the substance of the skin was soon dissolved into a pulp consisting of small black fragments; and on examining the polype with a microscope, it was found that the particles were driven about in the stomach, and that they passed into the arms, from thence back into the stomach; then to the tail, from whence they passed again into the arms, and so on. The grains of which the body of the polype consists, take their colour from the food with which it is nourished, and become red or black as the food happens to afford the one or the other. They are likewise more or less tinged with these colours in proportion to the strength of the nutritive juices; and it is observable that they lose their colour if fed with aliments of a colour different from themselves. They feed on most insects, and fish or flesh, if cut into small bits. Sometimes two polypes lay hold of the same worm, and each begins to swallow its own end till their mouths meet, and the worm breaks. But should this happen not to be the case, the one polype will sometimes devour the other along with its portion. It

Species. It appears, however, that the stomach of one polype is not fitted for dissolving the substance of another; for the one which is swallowed always gets clear again after being imprisoned an hour or two.

Zoophyta. The manner in which the polypes generate is most perceptible in the grisea and fusca, as being considerably larger than the viridis. If we examine one of them in summer, when the animals are most active, and prepared for propagation, some small tubercles will be found proceeding from its sides, which constantly increase in bulk, until at last in two or three days they assume the figure of small polypes. When they first begin to shoot, the excrescence becomes pointed, assuming a conical figure, and deeper colour than the rest of the body. In a short time it becomes truncated, and then cylindrical, after which the arms begin to shoot from the anterior end. The tail adheres to the body of the parent animal, but gradually grows smaller, until at last it adheres only by a point, and is then ready to be separated. When this is the case, both the mother and young ones fix themselves to the sides of the glass, and are separated from each other by a sudden jerk. The time requisite for the formation of the young ones is very different, according to the warmth of the weather and the nature of the food eaten by the mother. Sometimes, they are fully formed, and ready to drop off in 24 hours; in other cases, when the weather is cold, 15 days have been requisite for bringing them to perfection.

Species.
Zoophyta.

It is remarkable, that there is a reciprocal communication of food betwixt the young and old, before they be separated. The young ones, as soon as they are furnished with arms, catch prey for themselves, and communicate the digested food to the old ones, who on the other hand do the same to the young ones. This was fully verified by the following experiment. One of the large polypes of the fusca kind being placed on a slip of paper in a little water, the middle of the body of a young one growing out from it was cut open; when the superior part of that end which remained fixed to the parent was found to be open also. But cutting over the parent polype on each side of the shoot, a short cylinder was obtained, open at both ends; which being viewed through a microscope, the light was observed to come through the young one into the stomach of the old one. On cutting open the portion of the cylindrical portion lengthwise, not only the hole of communication was observed, but one might see through the end of the young one also. On changing the situation of the two pieces, the light was seen through the hole of communication. This may be seen between the parent polype and its young ones after feeding them; for after the parents have eaten, the bodies of the young ones swell as if they themselves had been eating.

The polypes produce young ones indiscriminately from all parts of their bodies, and five or six young ones have frequently been produced at once; nay, M. Trembley has observed nine or ten produced at the same time.

Nothing like copulation among these creatures was ever observed by M. Trembley, though for two years he had thousands of them under his inspection. To be more certain on this subject, he took two young ones

the moment they came from their parent, and placed them in separate glasses. Both of them multiplied, not only themselves, but also their offspring, which were separated and watched in the same manner to the seventh generation. They have even the same power of generation, while adhering to their parent. In this state the parent, with its children and grandchildren, exhibits a singular appearance, looking like a shrub thick set with branches. Thus several generations sometimes are attached to one another, and all of them to one parent. Mr Adams gives a figure of one polype with 19 young ones hanging at it; the whole group being about one inch broad, and one inch and a half in length; the old polype ate about 12 mofoculi per day, and the young ones about 20 among them.

When a polype is cut transversely or longitudinally into two or three parts, each part in a short time becomes a perfect animal; and so great is this prolific power, that a new animal will be produced even from a small portion of the skin of the old one. If the young ones be mutilated while they grow upon the parent, the parts so cut off will be reproduced; and the same property belongs to the parent. A truncated portion will send forth young ones before it has acquired a new head and tail of its own, and sometimes the head of the young one supplies the place of that which should have grown out of the old one. If we slit a polype longitudinally through the head to the middle of the body, we shall have one formed with two heads; and by again slitting these in the same manner, we may form one with as many heads as we please.

A still more surprising property of these animals is, that they may be grafted together. If the truncated portions of a polype be placed end to end, and gently pushed together, they will unite into a single one. The two portions are first joined together by a slender neck, which gradually fills up and disappears, the food passing from one part into the other; and thus we may form polypes, not only from different portions of the same animal, but from those of different animals. We may fix the head of one to the body of another, and the compound animal will grow, eat and multiply, as if it had never been divided. By pushing the body of one into the mouth of another, so far that their heads may be brought into contact, and kept in that situation for some time, they will at last unite into one animal, only having double the usual number of arms. The *hydra fusca* may be turned inside out like a glove, at the same time that it continues to eat and live as before. The lining of the stomach now forms the outer skin, and the former epidermis constitutes the lining of the stomach. If previous to this operation the polype have young ones attached to it, such as are newly beginning to vegetate turn themselves inside out, while the larger ones continue to increase in size till they reach beyond the mouth of the parent, and are then separated in the usual manner from the body. When thus turned, the polype combines itself in many different ways. The fore part frequently closes and becomes a supernumerary tail. The animal, which was at first straight, now bends itself, so that the two tails resemble the legs of a pair of compasses, which it can open and shut. The old mouth is placed as it were at the joint of the compasses, but loses its power of action; to supply which

Species.
Infusoria.

a new one is formed in its neighbourhood, and in a little time there is a new species of hydra found with several mouths.

The sides of a polype which has been cut through in a longitudinal direction, begin to roll themselves up, usually from one of the extremities, with the outside of the skin inwards; but in a little time they unroll themselves, and the two cut edges join together, sometimes beginning at one extremity, and sometimes approaching throughout their whole length. As soon as the edges join, they unite so closely that no scar can be perceived. If a polype be partly turned back, the open part closes, and new mouths are formed in different places. Every portion of a polype is capable of devouring insects, almost as soon as it is cut off, and the voracity of the whole tribe is astonishing; for Mr Adams observes, that most of the insects on which they feed bear the same proportion to the mouth of a polype, that an apple the size of a man's head bears to the mouth of a man.

The hydra pallens is very rarely met with, and is described by Mr Roiselle. It is of a pale yellow colour, growing gradually smaller from the bottom; the tail is round or knobbed; the arms are about the length of the body, of a white colour, generally seven in number, and are apparently composed of a chain of globules. The young are brought forth from all parts of its body.

The order *Zoophyta* contains 15 genera and 489 species.

ORDER V. INFUSORIA.

WE have already, under the article ANIMALCULE, treated of the general character and habits of the animals composing this order, and we can add little here to what has been said in that article. We shall therefore merely give the classification of the genera and species, and briefly notice a few of the more remarkable individuals.

Few writers have written expressly on this order; but the principal are Muller, Bruigiere, in the *Encyclopedie Methodique*, and Baker and Adams on the *Microscope*.

86
Brachionus.

68. BRACHIONUS.

Body contractile, covered with a shell, and furnished with rotatory cilia.

There are about 12 species, viz. *urceolaris*, *patella*, *cirratus*, *tripus*, *uncinatus*, *mucronatus*, *cernuus*, *calyciflorus*, *tubifex*, *quadridentatus*, *patina*, and *striatus*.

patina.

The *patina* is extremely bright and splendid, has a large body, a crystalline and nearly circular shell, without either incision or teeth, only towards the apex it falls in so as to form a smooth notch. A double glittering organ, with ciliated edges, projects from the apex; both of them of a conical figure, and standing as it were upon a pellucid substance, which is divided into two lobes, between which and the rotatory organ there is a silver-coloured crenulated membrane. Two small claws may likewise be discovered near the mouth.

striatus.

The *striatus* has an oblong, pellucid shell, capable of altering its figure. The apex is truncated, with six

small teeth on the edge of it, 12 longitudinal streaks down the back, the base obtuse and smooth. The teeth are occasionally protruded or retracted; and there are two small spines or horns on the other side of the shell. The animal itself is of a yellow colour, crystalline, and muscular; now and then putting out from the apex two or three little bundles of playing hairs, the two lateral ones shorter than that in the middle; on the outer side we may observe a forked deglutatory muscle, and two rigid points when the apex is drawn in. It is found in sea water.

Species.
Infusoria.

69. VORTICELLA.

87
Vorticella.

Body contractile, naked, and furnished with ciliate, rotatory organs.

There are about 57 species, which are arranged under three sections.

A. Seated on a pedicle or stem.

29 species, viz. **racemosa*, **polypina*, **anastatica*, **conglomerata*, **pyraria*, **opercularia*, **tuberosa*, **bians*, **bellis*, **umbellaria*, **berberina*, **digitalis*, **fasciculata*, **annularis*, **nutans*, **gemella*, **nebulifera*, **convallaria*, **lunaris*, **globularia*, **inclinans*, **ringens*, **pyriformis*, **stellata*, **vaginata*, **citrina*, **cyathina*, **putrida*, and **patellina*.

B. Furnished with a tail.

14 species, viz. **fusculosa*, **socialis*, **stentorea*, **hyacinthina*, **auriculata*, **furcata*, **senta*, **catulus*, **felis*, **vermicularis*, **macroura*, **rotatoria*, **lacinata*, and **sacculata*.

C. Without tail or stem.

14 species, viz. **ampulla*, **crataegaria*, **caniculata*, **nasuta*, **crateriformis*, **truncatella*, **limacina*, **discina*, **cornuta*, **cincta*, **polymorpha*, **viridis*, **bursata*, and **nigra*.

The *polypina*, when viewed through a small magnifier, appear like so many little trees; the upper part, or heads, are egg-shaped, the top truncated, the lower part filled with intestines; the branches thick set with little knobs. Fig. 16.

The *fasciculata* has a rotatory organ, which may sometimes be seen projecting beyond the aperture; there is a little head at the apex, and the pedicle is twisted and very slender. A congealed green mass which is often found swimming about in ditches is composed of myriads of these animals, which are not visible to the naked eye, and when magnified appear like a bundle of green flowers.

The *socialis*, when considerably magnified, appears like a circle surrounded with crowns or ciliated heads, tied by small thin tails to a common centre, from whence they advance towards the circumference, where they turn very briskly, occasioning a kind of whirlpool, which brings its food. When one of them has been in motion for some time, it stops, and another begins; sometimes two or three may be perceived in motion at once; they are frequently to be met with separate, with the tail sticking in the mud. The body contracts and dilates very much, so as sometimes to have the appearance of a oudgel, at others to assume almost a globular form.

Species.
Infusoria.
sculosa.

The *flosculosa* appears to the naked eye like a yellow globule adhering to the ceratophyllon like a little flower or a heap of yellow eggs. When magnified, they are seen to consist of a congeries of animalcula constituting a sphere from a mouldy centre. They contract and extend their bodies either alone or in society, and excite a vortex in the water by means of a disk. When they quit the society and act singly, they may be observed to consist of a head, abdomen, and tail; the head being frequently drawn back into the abdomen so far that it cannot be seen, only exhibiting a broad kidney-shaped disk standing out. The abdomen is oblong, oval, and transparent; the tail sharp, twice as long as the abdomen, sometimes rough and annulated, or altogether smooth.

long, slender, and finely proportioned neck, of a size suitable to the rest of the animal.

Species.
Infusoria.
89
Cercaria.

71. CERCARIA.

Animal invisible to the naked eye, pellucid, and furnished with a tail.

There are 13 species; viz. * *cyrinus*, * *inquieta*, * *lemna*, * *turbo*, * *podura*, * *mutabilis*, * *catellus*, * *lupus*, * *vermicularis*, * *pleuronectis*, * *tripus*, * *cyclidium*, and * *tenax*.

The *lemna* varies its form so much, that it might be mistaken for the proteus of Baker, described under the article ANIMALCULE: though in fact it is totally different. The body sometimes appears of an oblong, sometimes of a triangular, and sometimes of a kidney-shape. The tail is generally short, thick, and annulated; but sometimes long, flexible, cylindric, and without rings; vibrating, when stretched out, with so much velocity, that it appears double. A small pellucid globule, which Muller supposes to be its mouth, is observable at the apex; and two black points not easily discovered, he thinks, are its eyes. It walks slowly after taking three or four steps, and extends the tail, erecting it perpendicularly, shaking and bending it, in which state it very much resembles a leaf of the *lemna*.

88
trichoda.

70. TRICHODA.

Animal invisible to the naked eye, pellucid, hairy, or horned.

There are about 60 species, which are divided into three sections.

A. Hairy.

47 species, viz. *grandinella*, * *cometa*, * *granata*, * *sol*, * *bamba*, * *orbis*, * *urnula*, * *urinarium*, * *trigona*, * *tinea*, * *pubes*, * *proteus*, * *gibba*, * *patens*, * *uvula*, * *sulcata*, * *anas*, * *farcimen*, * *linter*, * *vermicularis*, * *melitæa*, * *fimbriata*, * *camelus*, * *rattus*, * *inquilinus*, * *innata*, * *transfuga*, * *ciliata*, * *cyclidium*, * *pulex*, * *lynceus*, * *charon*, * *cimex*, * *pellionella*, * *angulus*, * *ursula*, * *semiluna*, * *pupa*, * *pocillum*, * *clavus*, * *musculus*, * *delphinus*, * *clava*, * *cuniculus*, * *piasis*, * *larus*, and * *longicauda*.

B. Furnished with cirri.

Four species, viz. * *acarus*, * *ludis*, * *sannio*, and * *voluator*.

C. Horned.

Nine species, viz. * *lynceaster*, * *histrio*, * *cypris*, * *patella*, * *pullaster*, * *mytilus*, * *lepus*, * *silurus*, and * *calvitiun*.

randi-
lla.

The *grandinella* is a very small pellucid globule, with the intestines scarcely visible; the top of the surface furnished with several small bristles not easily discoverable, as the creature has a power of extending or drawing them back in an instant. It is found in pure water as well as in infusions of vegetables.

The *sol* is small, globular, and crystalline; beset everywhere with diverging rays longer than the diameter of the body; the inside full of molecules. The body contracts and dilates, but the creature remains confined to the same spot. It was found with other animalcules in water which had been kept three weeks.

vtus.

The *proteus* is that which Mr Baker distinguishes by the same name, and of which an account is given under the article ANIMALCULE. It is found in the slimy matter adhering to the sides of the vessel in which vegetables have been infused, or animal substances preserved. That described by Mr Adams was discovered in the slime produced from the water where small fishes, water snails, &c. had been kept. The body resembled that of a snail, the shape being somewhat elliptical, but pointed at one end, while from the other proceeded a

90
72. LEUCOPHRA. *Leucophra.*

Animal invisible to the naked eye, and every where ciliate.

There are eight species; viz. * *confictor*, * *vesiculifera*, * *acuta*, * *fluxa*, * *armilla*, * *cornuta*, * *heteroclitia*, and * *nodulata*.

91
73. GONIUM. *Gonium.*

Animal very simple, flat, angular, but invisible to the naked eye.

There are five species; viz. * *pectorale*, * *pulvinatum*, * *polysphericum*, * *truncatum*, and * *rectangulum*.

The *pectorale* is founded in pure water, and moves alternately towards the right and left. It is quadrangular and pellucid, with 16 spherical molecules, of a greenish colour, set in a quadrangular membrane, like the jewels in the breast-plate of the high priest, reflecting light on both sides.

92
74. COLPODA. *Colpoda.*

Animal invisible to the naked eye, very simple, pellucid, sinuate.

There are seven species; viz. * *lamella*, * *rostrum*, * *meleagris*, * *cucullus*, * *ren*, * *pyrum*, and * *hypocrepis*.

The *cucullus* is found in vegetable infusions, and in fetid hay, moving in all directions, and commonly with great velocity. It is very pellucid, and has a well defined margin, filled with little bright vesicles differing in size, and of no certain number. Its figure is commonly oval, with the top bent into a kind of beak, sometimes oblong, but most commonly obtuse. It has in the inside from 8 to 24 bright little vesicles not discernible in such as are young. Some have sup-

Species. posed these to be animalcules which this creature has swallowed; but Mr Muller is of opinion that they are its offspring. When this creature is near death by reason of the evaporation of the water, it protrudes its offspring with violence. From some circumstances it would seem probable that this animalcule casts its skin, as is the case with some insects.

There are 15 species; viz. *viridis*, * *punctifera*, *nodulosa*, *farcimen*, *semilunum*, *ovulum*, *pyrum*, *fusus*, *fritillus*, * *caudata*, *epistomium*, * *retrograda*, * *truncus*, *spatula*, and *papula*.

⁹³
Parame-
sium.

75. PARAMESIUM.

Worm invisible to the naked eye, simple, pellucid, flattened, oblong.

There are seven species; viz. * *aurelia*, *chrysalis*, * *oviferum*, * *marginatum*, *caudatum*, *anceps*, and *acutum*.

aurelia.

The *aurelia* is membranaceous, pellucid, and four times longer than it is broad; the fore part obtuse and transparent; the hind part filled with molecules. It has somewhat the appearance of a gimlet, by reason of a fold which goes from the middle to the apex, and is of a triangular figure. It moves in a rectilinear and vacillatory manner. It is found in ditches where there is plenty of duckweed; and will live many months in the same water without any renewal of it.

⁹⁴
Cyclidium.

76. CYCLIDIUM.

Worm invisible to the naked eye, very simple, pellucid, flat, orbicular or oval.

There are seven species; viz. * *bullia*, *miliium*, *glaucoma*, * *radians*, *rostratum*, * *nucleus*, and *pediculus*.

⁹⁵
Bursaria.

77. BURSARIA.

Worm very simple, membranaceous, hollow.

There are three species; viz. *truncatella*, * *hirundinella*, and * *duplella*.

⁹⁶
Vibrio.

78. VIBRIO.

Worm invisible to the naked eye; very simple, round, elongated.

There are 20 species; viz. *lineola*, *bacillus*, *undula*, *vermiculus*, *intestinum*, * *lanula*, *malleus*, * *serpentulus*, * *aceti*, * *glutinis*, * *anguilula*, *utriculus*, *fasciola*, *colymbus*, *cygnus*, * *anser*, * *olor*, *falx*, *diffluens*, and * *proteus*.

anser.

The *anser* is found in water where duckweed grows. The trunk is elliptic, round, and without any inequality on the sides. It is full of molecules; the hind part sharp and bright; the fore part produced into a bending neck, longer than the body; the apex whole and even, with blue canals passing between the marginal edges, occupying the whole length of the neck; and in one of them a violent descent of water to the beginning of the trunk is observable. It moves the body slow, but the neck more briskly.

⁹⁷
Enchelis.

79. ENCHELIS.

Worm invisible to the naked eye; very simple, cylindrical.

80. BACILLARIA.

⁹⁸
Bacillaria.

Body consisting of cylindrical straw-like filaments, placed parallel to each other, and frequently changing their position.

There is only one species; viz. *paradoxa*.

81. VOLVOX.

⁹⁹
Volvox.

Worm invisible to the naked eye; simple, pellucid, spherical.

There are nine species; viz. *globulus*, *pilola*, * *sphaerula*, *ava*, * *lanula*, *dimidiatus*, * *globator*, *pileus*, and *bullia*.

The *globator*, or *spherical membranaceous volvox*, is *globator*. found in great numbers in the infusions of hemp and tremella, and in stagnant waters in spring and summer. It was first observed and dissected by Leeuwenhoek; but the descriptions of it given by authors differ considerably from each other. The following is that of Mr Baker. "There is no appearance of either head, tail, or fins. It moves in every direction, backwards, forwards, up or down, rolling over and over like a bowl, spinning horizontally like a top, or gliding along smoothly without turning itself at all: sometimes its motions are very slow, at other times very swift; and when it pleases it can turn round as upon an axis very nimbly, without moving out of its place. The body is transparent, except where the circular spots are placed, which are probably its young. The surface of the body in some is as if all dotted over with little points, and in others as if granulated like shagreen. In general it appears as if set round with short moveable hairs." Another author informs us, that "they are first very small, but grow so large that they can be discerned with the naked eye; they are of a yellowish green colour, globular figure, and in substance membranaceous and transparent; and in the midst of this substance several small globes may be perceived. Each of these are smaller animalcula, which have also the diaphanous membrane, and contain within themselves still smaller generations, which may be distinguished by means of very powerful glasses. The larger globules may be seen to escape from the parent, and then increase in size."

This little animal appears like a transparent globule of a greenish colour, the fœtus being composed of smaller greenish globules. In proportion to its age it becomes whiter and brighter, and moves slowly round its axis; but to the microscope its surface appears as if granulated; the roundest molecules fixed in the centre being largest in those that are young. The exterior molecules may be wiped off, leaving the membrane naked. When the young ones are of a proper size, the membrane opens, and they pass through the fissure, after which the mother melts away. Sometimes they change their spherical figure, and become flat in several places.

They

Fig. 1.



Fig. 2.



Fig. 4.



Fig. 6.



Fig. 5.



Fig. 3.



Fig. 8.

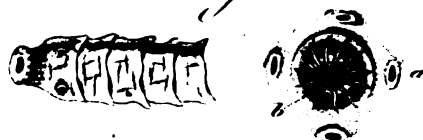
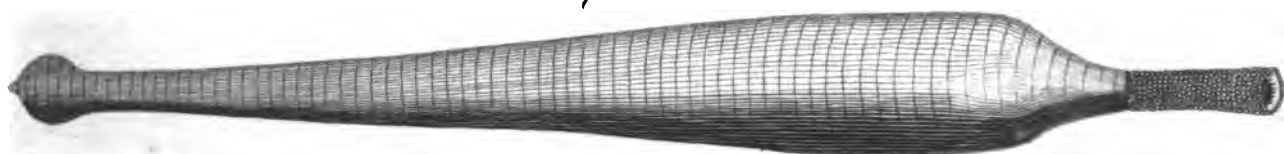

Fig. 7.



Fig. 9.



W. Archibald sculp.

Fig. 10.

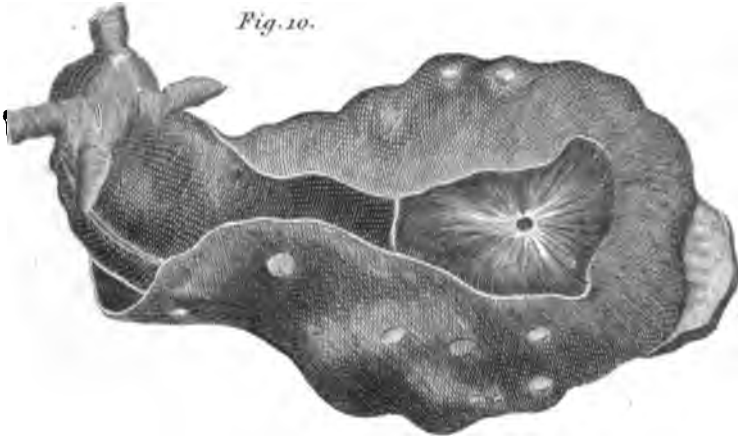

Fig. 11.

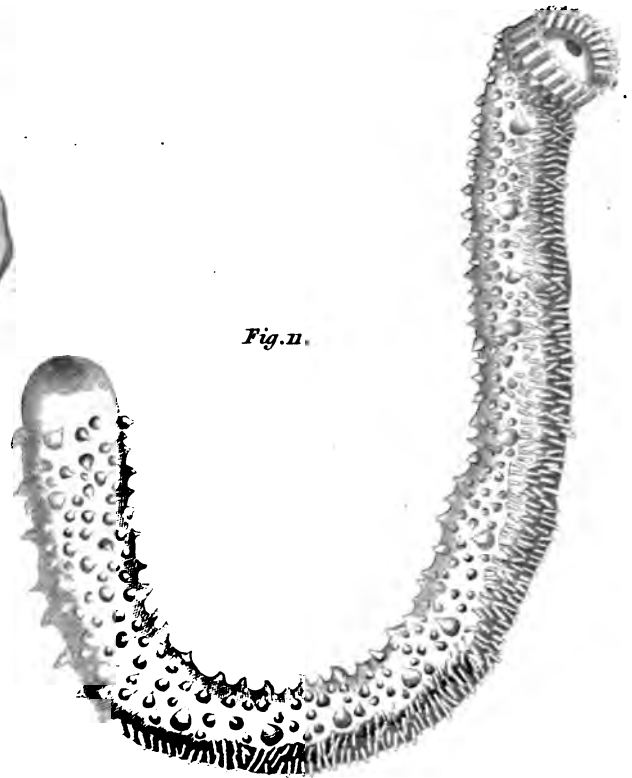

Fig. 12.

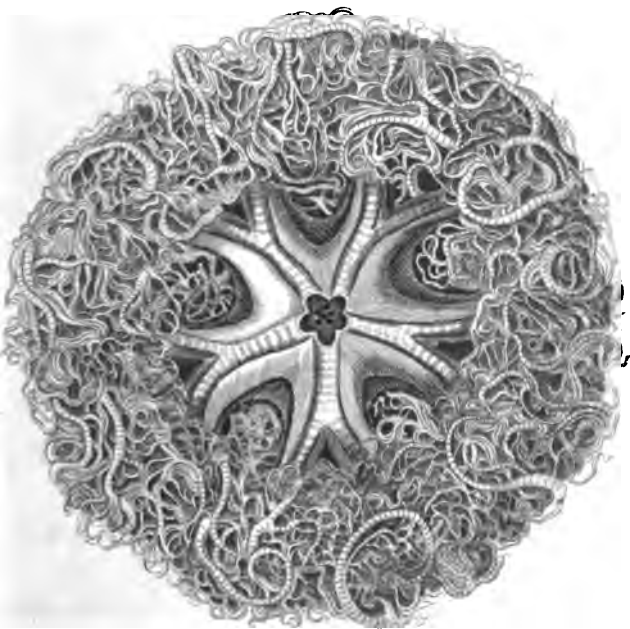
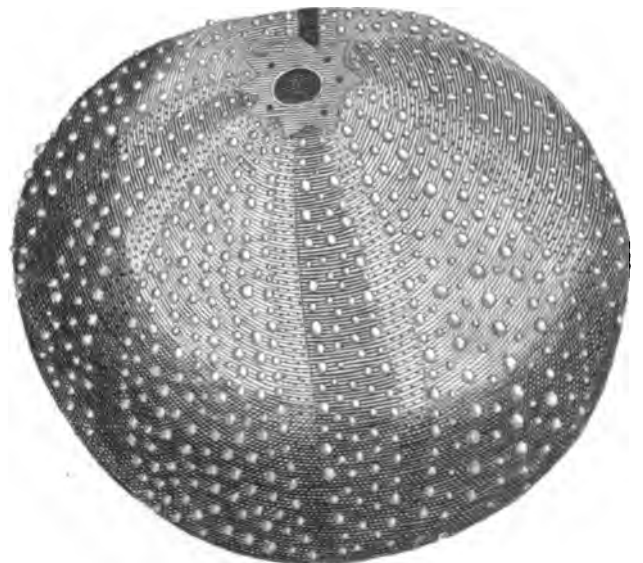

Fig. 13.



W. B. Woodcock sculp.

c. They contain from 8 to 30 and 40 globules within the membrane.

82. MONAS.

Worm invisible to the naked eye; most simple, pellucid, resembling a point.

There are five species; viz. *atomus, punctum, *mica, *lens, and termo.

This order contains 15 genera and 229 species.

How many kinds of these invisibles there may be (says Mr Adams), is yet unknown; as they are discerned of all sizes, from those which are barely invisible to the naked eye, to such as resist the force of the microscope as the fixed stars do that of the telescope, and with the greatest powers hitherto invented, appear only as so many moving points. The smallest living creatures our instruments can shew, are those which inhabit the waters; and though animalcula equally minute may fly in the air, or creep upon the earth, it is scarce possible to get a view of them; but as water is transparent, by confining the creatures within it we can more easily observe them by applying a drop of it to the glasses.

Animalcules in general are observed to move in all directions with equal ease and rapidity; sometimes obliquely, sometimes straight forward; sometimes moving in a circular direction, or rolling upon one another, removing backwards and forwards through the whole extent of the drop, as if diverting themselves; at other times greedily attacking the little parcels of matter

they meet with. Notwithstanding their extreme minuteness, they know how to avoid obstacles, or to prevent any interference with one another in their motions: sometimes they will suddenly change the direction in which they move, and take an opposite one; and by inclining the glass on which the drop of water is, as it can be made to move in any direction, so the animalcules appear to move as easily against the stream as with it. When the water begins to evaporate, they flock towards the place where the fluid is, and shew a great anxiety and uncommon agitation of the organs with which they draw in the water. These motions grow languid as the water fails, and at last cease altogether, without a possibility of renewal if they be left dry for a short time. They sustain a great degree of cold as well as insects, and will perish in much the same degree of heat that destroys insects. Some animalcules are produced in water at the freezing point, and some insects live in snow. By mixing the least drop of urine with the water in which they swim, they instantly fall into convulsions and die.

The same rule seems to hold good in these minute creatures, which is observable in the larger animals, viz. that the larger kinds are less numerous than such as are smaller; while the smallest of all are found in such multitudes, that there seem to be myriads for one of the others. They increase in size, like other animals, from their birth until they have attained their full growth; and when deprived of proper nourishment, they in like manner grow thin and perish.

Species.
Infusoria.

EXPLANATION OF FIGURES.

Fig. 1. *Ascaris Lumbricoides*, entire, and nearly of its natural size; *a*, the head; *b*, the tail; *c*, the depressed band; *d*, the punctiform aperture; *e*, the line extending from the head to the tail; *f*, the gyrated apparatus as it appears through the skin of the worms.

Fig. 2. Represents the viscera of the worm in their natural situation; *a*, the head; *b*, the gullet; *c*, the intestinal canal; *d*, the lines of the body of the worm; *e*, the uterus, and its convoluted apparatus.

Fig. 3. *Ascaris Vermicularis* of its natural size.

Fig. 4. The same viewed by the microscope; *a*, the head; *b*, the tail; *c*, the pistilliform stomach; *d*, a convoluted apparatus surrounding the intestinal canal; *e*, an orifice which is probably the anus; *f*, the external part of the organs of generation.

Fig. 5. *Trichuris Hominis*, of its natural size.

Fig. 6. The same considerably magnified; *a*, the head; *b*, the tail; *c*, the proboscis; *d d*, the intestinal canal; ** a hollow tube; *X* the ovaria.

Fig. 7. A portion of the *Tænia Solium*, of its natural size, and usual appearance; *a a*, the marginal oscula.

Fig. 8. *a*, the head enlarged by the microscope; *b*, a full view of the head when very much magnified; *a*, the oscula at the base; *c*, the mouth.

Fig. 9. *Sipunculus Saccatus*, of its natural appearance.

Fig. 10. *Laplysia Depilans*, or Sea-hare.

Fig. 11. *Holothuria Tremula*.

Fig. 12. *Asterias Caput Medusæ*, or Arborescent Sea-star.

Fig. 13. *Echinus Esculentus*, or common Sea-urchin.

Fig. 14. *Tubularia Magnifica*, as it proceeds from its native rocks; *a*, the animal with its tentacula fully expanded from the tube; *b*, another with the tentacula collapsed; *c*, one with the tentacula nearly withdrawn into the tube; *d*, the animal with the tentacula entirely withdrawn; *e, e, e*, probably *actinæ*.

Fig. 15. *Hydra Grisea*, or Fresh-water Polype, magnified; *a*, the mouth; *b*, the attached part; *c, c, c.* &c. the arms; *e*, the transparent body.

Fig. 16. *Vorticella Polypina*, magnified.

INDEX.

INDEX.

A.			E.			Helminthology the most imperfect part of natural history, difficulties attending the study of, advantages of, N° 8		
<i>ACTINIA</i> ,	p. 335	N° 39	<i>Earth-worm</i> ,	p. 346				
<i>Alcyonium</i> ,	336	77	how different					
<i>Amphitrite</i> ,	ib.	61	from ascaris					
<i>Antipathes</i> ,	ib.	75	lumbricoides,	N° 36				
<i>Aphrodita</i> ,	ib.	60	<i>Echinorhynchus</i> ,	334	24	<i>Hirudo</i> ,	P. 335	33
aculeata,	353		mammalium,	341		medicinalis,	345	
<i>Argus</i> , sea,	351		avium,	ib.		sanguisuga,	346	
<i>Ascarides</i> ,	337		reptilium,	ib.		<i>Holothuria</i> ,	335	32
<i>Ascaris</i> ,	334	15	piscium,	ib.		tremula,	351	
lumbricoides,	338		<i>Echinus</i> ,	336	69	<i>Horn-wrack</i> ,	358	
vermicularis,	339		esculentus,	356		<i>Horse hair</i> , animated,	345	
mammalium,	ib.		<i>Eggs</i> , sea,	ib.		leech,	346	
avium,	ib.		<i>Enchelis</i> ,	337	96	<i>Hydatids</i> ,	P. 342,	343
reptilium,	ib.					<i>Hydra</i> ,	336	84
piscium,	ib.					viridis,	359	
lumbrici,	340					fusca,	360	
<i>Ascidia</i> ,	335	43	F.					
papillosa,	348		<i>Fasciola</i> ,	334	28	L.		
intestinalis,	ib.		hominis,	342		<i>Infusoria</i> ,	P. 337, 362	
<i>Asterias</i> ,	336	68	mammalium,	ib.		<i>Intestina</i> ,	334, 337	
caput medusæ,	355		hepatica,	ib.		<i>Isis</i> ,	336	74
			avium,	ib.				
			reptilium,	ib.				
			piscium,	ib.				
			loliginis,	ib.				
B.			<i>Filaria</i> ,	334	18	L.		
<i>Bacillaria</i> ,	337		medinensis,	340		<i>Laplysia</i> ,	335	49
<i>Brachionus</i> ,	ib.	85	<i>Fluke</i> ,	342		<i>Leech</i> , medicinal,	345	
striatus,	362		<i>Flustra</i> ,	336	79	mode of applying,		34
patina,	ib.		<i>Furia</i> ,	335	31	horse,	346	
<i>Bursaria</i> ,	337	94	infernalis,	345		<i>Lernæa</i> ,	336	59
						<i>Leucophaea</i> ,	337	89
						<i>Ligula</i> ,	334	21
						<i>Limas</i> ,	335	48
						agrestis,	349	
C.			G.			<i>Lingustula</i> ,	334	44
<i>Caryophyllæus</i> ,	334	27	<i>Generic characters</i> ,	12		<i>Lobaria</i> ,	336	58
<i>Cellepora</i> ,	ib.	73	of the intestina,	13		<i>Lucernaria</i> ,	ib.	67
<i>Cercaria</i> ,	337	88	mollusca,	14		<i>Lumbricus</i> ,	335	45
lemna,	363		zoophyta,	15		terrestris,	346	
<i>Clava</i> ,	335	40	infusoria,	16				
<i>Clio</i> ,	336	56	<i>Gonium</i> ,	337				
<i>Colpada</i> ,	337	91	pectorale,	363				
cucullus,	363		<i>Gordius</i> ,	335	32			
<i>Corallina</i> ,	336	81	aquaticus,	345				
<i>Cucullanus</i> ,	334	26	<i>Gorgonia</i> ,	336	76	M.		
mammalium,	342		<i>Gourd-worm</i> ,	342		<i>Madrepora</i> ,	336	71
buteonis,	ib.		<i>Guinea-worm</i> ,	340		<i>Mammaria</i> ,	335	42
avium,	ib.					<i>Mat-wood</i> , sea,	358	
piscium,	ib.					<i>Medusa</i> ,	336	66
<i>Cuttle-fish</i> ,	352					<i>Millepora</i> ,	ib.	72
<i>Cuvier's classification of worms</i> ,	11					<i>Mollusca</i> ,	P. 335, 348	
<i>Cyclidium</i> ,	337	93	H.			<i>Monas</i> ,	337	99
glaucoma,	364		<i>Hæruca</i> ,	334	25			
			<i>Hair-worm</i> ,	345				
			<i>Hars</i> , sea,	350				
			<i>Hedgehog's</i> , sea,	356				
			<i>Helminthology</i> , definition of,					
			division of,					
			intestina,					
			mollusca,					
			testacea,					
			zoophyta,					
			infusoria,					
D.						N.		
<i>Dagysia</i> ,	335	45				<i>Nais</i> ,	336	64
<i>Derris</i> ,	ib.	47				<i>Nereis</i> ,	ib.	63
<i>Dew-worm</i> ,	346					noctiluca,	354	
<i>Doris</i> ,	335	50				<i>Nettles</i> , sea,	ib.	
argo,	351							
<i>Dracunculus</i> ,	340					O.		
						<i>Onchidium</i> ,	336	57
								P.

HELMINTHOLOGY.

K.									
	P.		<i>Spongia,</i>	p. 336	N ^o 78	<i>Trichuris hominis,</i>	p. 340		
<i>vesium,</i>		p. 337	<i>officinalis,</i>	358		<i>mammalium,</i>	ib.		
<i>aurelia,</i>		364	<i>Star-fish, sea,</i>	355		<i>Triton,</i>	335	N ^o 54	
<i>llaria,</i>		335	<i>Strongylus,</i>	334	23	<i>Tube-worm,</i>	347		
<i>ea,</i>		359				<i>Tubipora,</i>	336	70	
<i>tula,</i>		336	T.			<i>Tubularia,</i>	ib.	80	
<i>phora,</i>		ib.	<i>Tænia,</i>	335	29	<i>magnifica,</i>	358		
<i>ria,</i>		335	<i>visceralis,</i>	342					
<i>is,</i>		359	<i>cellulosa,</i>	343		V.			
<i>rachea,</i>		335	<i>mammalium,</i>	p. 343,	344	<i>Vibrio,</i>	337	95	
	S.		<i>avium,</i>	344		<i>anser,</i>	364		
		335	<i>reptilium,</i>	p. 343,	345	<i>Uncinaria,</i>	334	19	
		334	<i>truttæ,</i>	343		<i>Volvox,</i>	337	98	
		336	<i>sodium,</i>	ib.		<i>globator,</i>	364		
		ib.	<i>lata,</i>	344		<i>Vorticella,</i>	337	86	
		55	<i>nodulosa,</i>	ib.		<i>polypina,</i>	362		
<i>officinalis,</i>		353	<i>Tape-worm,</i>		30	<i>fasciculata,</i>	ib.		
<i>octopus,</i>		ib.	<i>Terebella,</i>	335	53	<i>socialis,</i>	ib.		
<i>ria,</i>		336	<i>lapidaria,</i>	352		<i>flosculosa,</i>	363		
<i>ulus,</i>		335	<i>Tethis,</i>	335	51	<i>Urchin, sea,</i>	356		
<i>nudus,</i>		347	<i>Trichoda,</i>	337	87				
<i>saccatus,</i>		ib.	<i>grandinella,</i>	363					
<i>pinning,</i>		349	<i>sol,</i>	ib.		Z.			
		336	<i>Trichuris,</i>	334	17	<i>Zoophyta,</i>	p. 336,	356	

H E L

HELMONT, JOHN-BAPTIST VAN, a leader of distinction in the chemical school of medicine, was born at Brussels in the year 1577, and descended of a noble family. He studied medicine at Louvain and some other places with so much avidity, that he had perused Hippocrates, Galen, and the Greek and Arabian physicians at a very period of life. When not more than 17 years of age, he read public lectures at Louvain, and was created M. D. in the year 1559 when only 22. Having, in 1609, married a wife who was both rich and noble, he retired with her to Vilforde, where he practised as a physician without taking any fees, and was accustomed to boast of the thousands whom he cured every year, although his success in his own family was by no means great; for his eldest daughter died of a leprosy, and he lost two sons by the plague. He published a variety of works, by which he acquired very great reputation. He was invited to the court of Vienna by the emperor Rodolph, which he declined to accept. He died in the year 1644, in the 68th year of his age.

He was a man of acute genius, clear-sighted in detecting the mistakes of others, and extremely fond of forming hypotheses of his own, which were not always supported by conclusive arguments. He affirmed with boldness, was extremely credulous, and fond of such extravagant narrations as seemed to favour his own preconceived opinions. Perhaps his greatest foible was the liberal manner in which he praised himself, in reference to his own nostrums and pretended specifics. His ideas were far from being perspicuous, chiefly owing to his making use of terms and phrases which he never properly defined. He added much, however, to the stock of chemical facts at that time known, and paved the way to more interesting discoveries. He

H E L

contributed more than any of his predecessors, to subvert the Galenical theory of humours and qualities, which he certainly combated with many forcible arguments. His theory of ferments was in a great measure espoused by Sylvius. His son Francis-Mercurius first published his works collectively in 1648; and although it cannot be denied that they abound with jargon and error, they contain many pertinent remarks, and much curious and interesting speculation.

HELMONT, a small town in the Netherlands, in Dutch Brabant, and capital of the district of Peeland, with a good castle. It is seated on the river As, in E. Long. 5. 37. N. Lat. 51. 31.

HELMSTADT, a town of Germany, in the duchy of Brunswick, built by Charlemagne, in E. Long. 11. 10. N. Lat. 52. 20.

HELMSTADT, a strong maritime town of Sweden, and capital of the province of Halland, seated near the Baltic sea; in E. Long. 21. 5. N. Lat. 56. 44.

HELONIAS, a genus of plants belonging to the hexandria class; and in the natural method ranking under the 10th order, *Coronaria*. See *BOTANY Index*.

HELOISE, celebrated on account of her unfortunate affection for her tutor Abelard, and for her Latin letters to him after they had retired from the world. She died abbess of Paraclet in 1163. See *ABELARD*.

HELOS, in *Ancient Geography*, a maritime town of Laconia, situated between Trinasus and Acriæ, in Pausanias's time in ruins. The district was called *Helotea*, and the people *Helotes*, *Helotæ*, *Helei*, and *Heleatæ*, by Stephans; and *Ilotæ*, by Livy. Being subdued by the Lacedæmonians, they were all reduced to a state of public slavery, or made the slaves of the public, on these conditions, viz. that they neither could recover their liberty nor be sold out of the territory of Sparta.

Helmont
Helos.

Helos
Helvetius.

Hence the term *αλαστων*, in Harpocration, for being in a state of slavery; and hence also the Lacedæmonians called the slaves of all nations whatever *helotes*. *Heloticus* is the epithet.

HELOTS, in Grecian antiquity, the slaves of the Spartans. See HELOS.—The freemen of Sparta were forbidden the exercise of any mean or mechanical employment, and therefore the whole care of supplying the city with necessaries devolved upon the Helots.

HELSINBURG. See ELSIMBURG.

HELSINGIA, a province of Sweden, bounded on the north by Jempterland and Medelpadia, on the east by the Bothnic gulf, and on the south and west by Dalecarlia and Gestrícia. It is full of mountains and forests, and the inhabitants are almost constantly employed in hunting and fishing. It has no cities: the principal towns are, Hudwickvald, Alta, and Dilsbo.

HELSINGIC CHARACTER, a peculiar kind of character found inscribed on stones in the province of Helsingia. The Runic and Helsingic characters may be easily transformed into each other.

HELSTON, a town of Cornwall in England, seated on the river Cober, near its influx into the sea, one of the towns appointed for the coinage of tin, and the place of assembly for the west division of the county. It had formerly a priory and a castle, and sent members to parliament in the reign of Edward I. but was not incorporated till the time of Queen Elizabeth. It was re-incorporated in 1774. A little below the town there is a tolerable good harbour, where several of the tin-ships take in their lading. King John exempted this place from paying toll any where but in the city of London. It contained 2297 inhabitants in 1811, and sends two members to parliament.

HELVELLA, a genus of the natural order of fungi, belonging to the cryptogamia class of plants. See BOTANY *Index*.

HELVETIC, something that has a relation to the inhabitants of the Swiss cantons, who were anciently called *Helvetii*.—The Helvetic body comprehends the republic of Switzerland, consisting of 13 cantons, which make so many particular commonwealths. By the laws and customs of the Helvetic body, all differences between the several states and republics are to be decided within themselves, without the intervention of any foreign power. The government of this body, before its subjugation to France, was chiefly democratic, with some mixture of the aristocratic.

HELVETII, a people of Belgica, in the neighbourhood of the Allobroges and the Provincia Romana; famed for bravery and a turn for war. Called *Civitas Helvetia*, and divided into four pagi or cantons; situated to the south and west of the Rhine, by which they were divided from the Germans; and extending towards Gaul, from which they were separated by Mount Jura on the west, and by the Rhodanus and Lacus Lemanus on the south, and therefore called a Gallic nation (Tacitus, Cæsar, Strabo, Ptolemy, Pliny). Formerly a part of Celtic Gaul, but by Augustus assigned to Belgica.

HELVETIUS, CLAUD-ADRIAN, a man of letters, and celebrated French philosopher, was born at Paris, in the year 1715. After receiving the rudiments of his education in his father's house, he was sent to the college of Louis the Great, where he discovered greater

indications of genius than any of his fellow students, and thus gained the esteem of the professor of rhetoric, by whom particular attention was paid to his education. By his elegant and graceful exterior he endeavoured to ingratiate himself with the fair sex; but he was soon convinced, that although external accomplishments may dazzle for the moment, nothing short of intellectual accomplishments can secure the conquest. The circumstance which led him to perceive the absolute necessity of mental improvement in order to be truly esteemed and admired, is worthy of notice. When walking alone in one of the public gardens, he discovered a most extravagant figure amidst a circle of young and amiable ladies. This was M. Maupertuis, who engrossed all the care and attention of this charming group, notwithstanding the ridiculous and grotesque singularity of his dress. This convinced Helvetius that if he wished to be sincerely admired or esteemed, dancing, tennis, and all other bodily exercises must give place to the decoration of his mind. He therefore immediately became a solitary, silent student, and the mathematics in particular first attracted his notice; and in a short time he was deemed a fit companion for some of the first and most distinguished literary characters of the period in which he flourished. Voltaire and Montesquieu were among his early intimates; with the latter of whom he contracted a cordial and lasting friendship.

The first literary performance of M. Helvetius was of the poetical kind, consisting of epistles on happiness, but these were not communicated to the public till after his decease. When read in private, however, they were very much admired, and Voltaire considered them as a strong proof of the didactic and philosophical powers of their author. When the *L'Esprit des Loix* of Montesquieu appeared in public, it was studied by Helvetius with the utmost care and attention, and his only fault to it was, that it did not contain the first ideas of the things of which it professed to treat. Instead of examining systems of legislation, and comparing them with each other, Helvetius was of opinion, that the nature of man should be first studied, and the laws for governing him founded on his own nature. This was true philosophy, and such ideas determined him to undertake a work which might supply what he conceived to be defects in the publication of Montesquieu. In the year 1758 this work made its appearance, under the title of *De l'Esprit*, &c. which was condemned by the parliament of Paris, because it was considered as degrading the nature of man; but this impolitic method of suppressing his labours made them sought for with avidity all over France, as well as other European countries, and gave them more importance than perhaps they would have otherwise acquired.

To avoid the malice of his enemies, he came over to England in the year 1762, and in the following year he went to Prussia, where he was received by the king with every mark of respect, who gave him lodgings in the palace, and admitted him into his familiar parties. He was uncommonly liberal to the indigent, some of whom but ill requited him, on which occasions he was wont to say to his friends, "If I were a king, I would correct them; but as I am only rich, and they are poor, I did my duty in relieving them." Notwithstanding his constitution was excellent, from which his friends concluded that they would long enjoy the happiness of

Helvetius.

his

vetius
H
merobaptists.
his society, he fell a victim to the gout in his head and stomach in the month of December 1771, in the 56th year of his age.

Besides his work *De l'Esprit*, he was the author of a "Treatise on Man, his Intellectual Faculties and his Education," in 2 vols. 8vo. published after his death. In both it must be confessed that he has displayed very great ingenuity and taste, an extensive knowledge of human nature, and a turn for ridiculing the follies of mankind; but some of his hypotheses appear rather paradoxical, and perhaps his ironical observations on credulity and false religion can hardly be reconciled with a belief of genuine Christianity, which he openly professes.

HELVIDIANS, a sect of ancient heretics, denominated from their leader Helvidius, a disciple of Auentius the Arian, whose distinguishing principle was, that Mary, the mother of Jesus, did not continue a virgin, but had other children by Joseph.

HELVOET-SLUYS, a sea-port town of the United Netherlands, seated on the island of Voorn, in the province of Holland, and where the English packet-boat always goes. It is but a small place, consisting only of a handsome quay, and two or three little streets. But it is very well fortified, and esteemed the safest harbour in the country. The largest men of war may come up to the middle of the town; and yet it has but very little trade, because the merchants choose to live higher up the country. It surrendered to the French in 1795. E. Long. 3. 58. N. Lat. 52. 41.

HEMATH, or HAMATH, in *Ancient Geography*, the name of a city (whose king was David's friend, 2 Sam. ix.) to the south of Lebanon, from which a territory was called *Hemath*, on the north of Canaan and south of Syria, as appears by the spies, Numb. xii. 1 Kings viii. Ezek. xlvii. Whether one or more cities and districts of this name lay in this tract, neither interpreters nor geographers are agreed. The eastern part was called *Hemath-zoba*, 2 Chron. viii. unless we suppose that there was a city in *Zoba* of this name, fortified by Solomon. In defining the boundary of Palestine, it is often said, *from the entering of Hamath*; as a province to be entered into through a strait or defile. And if there was such, the next question is, From what metropolis it was called *Hemath*? Antioch, capital of Syria, is supposed to be called *Hemath* or *Amatha*, (Jonathan, Targum, &c.); and again, *Epiphania*. (Josephus). Both were to the north of Lebanon; consequently not the *Hemath* of Scripture, the immediate boundary of Palestine to the north, and lying to the south of Lebanon.

HEMATITES, an ore of iron. See HEMATITES, MINERALOGY *Index*.

HEMEROBAPTISTS, a sect among the ancient Jews, thus called from their washing and bathing every day, in all seasons; and performing this custom with the greatest solemnity, as a religious rite necessary to salvation.

Epiphanius, who mentions this as the fourth heresy among the Jews, observes, that in other points these heretics had much the same opinions as the Scribes and Pharisees; only that they denied the resurrection of the dead, in common with the Sadducees; and retained a few other of the improprieties of these last.

The sect who pass in the East under the denomina-

tion of Sabians, calling themselves *Mendai Iahi*, or *the disciples of John*, and whom the Europeans entitle *the Christians of St John*, because they yet retain some knowledge of the gospel, is probably of Jewish origin, and seems to have been derived from the ancient Hemerobaptists; at least it is certain, that that John, whom they consider as the founder of their sect, bears no sort of similitude to John the Baptist, but rather resembles the person of that name whom the ancient writers represent as the chief of the Jewish Hemerobaptists. These ambiguous Christians dwell in Persia and Arabia, and principally at Bassora; and their religion consists in bodily washings, performed frequently, and with great solemnity, and attended with certain ceremonies, which the priests mingle with this superstitious service.

HEMEROBIUS, a genus of insects belonging to the neuroptera order. See ENTOMOLOGY *Index*.

HEMEROCALLIS, DAY-LILY, or *Lily Asphodel*; a genus of plants belonging to the hexandria class, and in the natural method ranking under the 10th order, *Coronariae*. See BOTANY *Index*.

HEMERODROMI, (compounded of *ἡμέρα*, "day," and *δρομος*, "course," &c.) among the ancients, were sentinels or guards, appointed for the security and preservation of cities and other places. They went out of the city every morning, as soon as the gates were opened, and kept all day patrolling round the place; sometimes also making excursions farther into the country, to see that there were no enemies lying in wait to surprise them.

HEMERODROMI were also a sort of couriers among the ancients, who only travelled one day, and then delivered their packets or dispatches to a fresh man, who run his day, and so on to the end of his journey. The Greeks had couriers of this kind, which they derived from the Persians, who were the inventors thereof, as appears from Herodotus. Augustus had the same; at least he established couriers, who, if they did not relieve each other from day to day, yet did it from space to space, and that space was not very great.

HEMEROTROPHIS, in antiquity, a measure of capacity, the same with the choenix. It was so called from its holding one day's food. The word is compounded of *ἡμέρα*, a day, and *τροφή*, food.

HEMI, a word used in the composition of divers terms. It signifies the same with *semi* or *demi*, viz. "half;" being an abbreviate of *ἡμισυς*, *hemisys*, which signifies "the same." The Greeks retrenched the last syllable of the word *ἡμισυς* in the composition of words; and after their example, we have done so too in most of the compounds borrowed from them.

HEMICRANIA, in *Medicine*, a species of cephalalgia, or headach; wherein only one side of the head is affected; and owing to a congestion of blood in the vessels of that half.

HEMICYCLE, HEMICYCLUM, compounded of *ἡμισυς*, half, and *κύκλος*, circle; a semicircle.

HEMICYCLE is particularly applied, in *Architecture*, to vaults in the cradle form; and arches or sweeps of vaults, constituting a perfect semicircle. To construct an arch of hewn stone, they divide the hemicycle into so many voussoirs; taking care to make them an uneven number, that there be no joint in the middle, where the key-stone should be. See KEY and BRIDGE.

Hemero-
baptists
Hemicycle.

Hemicy-
clium
Hemitri-
tous

HEMICYCLUM was also a part of the orchestra in the ancient theatre. Scaliger, however, observes, it was no standing part of the orchestra; being only used in dramatic pieces, where some person was supposed to be arrived from sea, as in Plautus's *Rudens*.

The ancients had also a sort of sun-dial, called *hemicyclium*. It was a concave semicircle, the upper end or cusp whereof looked to the north. There was a style, or gnomon, issuing from the middle of the hemicycle, whereof that point corresponding to the centre of the hemicycle represented the centre of the earth; and its shadow projected on the concavity of the hemicycle, which represented the space between one tropic and another, the sun's declination, the day of the month, hour of the day, &c.

HEMIMERIS, a genus of plants belonging to the didynamia class. See *BOTANY Index*.

HEMINA, in Roman antiquity, a liquid measure, which, according to Arbuthnot, was equal to half a wine pint English measure; its contents being 2.818 solid inches.

HEMIBOLON, a weight often mentioned by the ancient writers in medicine, and expressing the half of their obolus, or the twelfth part of a drachm, that is, five grains.

HEMIONITIS, a genus of plants of the order of filices, belonging to the cryptogamia class. See *BOTANY Index*.

HEMIPLEGIA, or **HEMIPLEXIA**, among physicians, a palsy of one half of the body. See *MEDICINE Index*.

HEMIPTERA, derived from *hemis*, half, and *pteron*, wing, in the Linnæan system, the second order of insects, comprehending the *blatta*, *mantis*, *gryllus*, &c. See *ENTOMOLOGY Index*.

HEMISPHERE, (**HÆMISPHERIUM**, compounded of *hemis*, half, and *sphaera*, sphere), in *Geometry*, is one half of a globe or sphere, when divided into two by a plane passing through its centre.

HEMISPHERE, in *Astronomy*, is particularly used for one-half of the mundane sphere.

The equator divides the sphere into two equal parts, called the *northern* and *southern hemispheres*. The horizon also divides the sphere into two parts, called the *upper* and *lower hemispheres*.

HEMISPHERE is also used for a map, or projection, of half the terrestrial globe, or half the celestial sphere, on a plane. Hemispheres are frequently called *planispheres*.

HEMISTICH, in *Poetry*, denotes half a verse, or a verse not completed.

Of this there are frequent examples in Virgil's *Æneid*; but whether they were left unfinished by design or not is disputed among the learned: such are, *Ferro accincta vocat*, *Æn. ii. 614*. And, *Italiam non sponte sequor*, *Æn. iv. 361*.

In reading common English verses, a short pause is required at the end of each hemistich or half verse.

HEMITONE, in the ancient music, was what we now call a half note or semitone.

HEMITRITÆUS, in *Medicine*, a kind of fever, denoting the same as semi-tertian, returning twice every day. The word is Greek, and compounded of *hemis*, "half," and *tertios*, "third or tertian."

Hemlock
Hemp

HEMLOCK. See *CICUTA* and *CONIUM*, *BOTANY* and *MATERIA MEDICA Index*.

HEMOPOTON. See *ORATORY*, No 77.

HEMP. See *CANNABIS*, *BOTANY Index*.—It does not appear that the ancients were acquainted with the use of hemp, in respect of the thread it affords. Pliny, who speaks of the plant in his natural history, lib. xx. cap. 23. says not a word of this; contenting himself with extolling the virtues of its stem, leaves, and root. In effect, what some writers of the Roman antiquities remark, viz. that the hemp necessary for the use of war was all stored up into two cities of the western empire, viz. at Ravenna and Vienne, under the direction of two procurators, called *procuratores linificii*, must be understood of linum or flax.

The use of hemp is so extensive and important, that vast quantities of it are annually imported into this and other kingdoms from those countries where it grows in greatest plenty, of which Russia is one. In the year 1763, the quantity imported into England alone amounted to 11,000 tons. Sir John Sinclair informs us, that in the year 1785, the quantity exported from Petersburg in British ships was as follows.

	Poods.
Clean Hemp	1,038,791
Outshot	38,282
Half-clean	18,374
Hemp-codille	19,251
	1,113,798

Now, allowing 63 poods to a ton, the quantity just mentioned will amount to 17,695 tons; and supposing it to take five acres to produce a ton of hemp, the whole quantity of ground, requisite for this purpose would amount to 88,475 acres.

By other accounts, the annual export of hemp to England is valued at 400,000l.; but by a computation of the whole imported into Britain and Ireland in 1788, it would seem that a considerably greater quantity must fall to the share of England. In that year the quantity amounted to no less than 58,464 tons; which at 20l. per ton amounted to 1,269,280l. We cannot wonder at this vast consumpt, when it is considered that the sails and cordage of a first rate man of war require 180,000 lb. of rough hemp for their construction; but even this will scarce account for the enormous consumpt in France, which in the year 1783 is said to have amounted to upwards of 400 millions of pounds, or 200,000 tons; of which more than one-third was imported.

Only the coarser kinds of hemp are employed in making cordage, the better sorts being used for linen, which, though it can never be made so fine as that from flax, is yet incomparably stronger, and equally susceptible of bleaching both in the old and new way. Cloths made of hemp have also this property, that their colour improves by wearing, while that of linen decays. The prices of hemp linen are various; from 10d. to 4s. 6d. per yard. The low-priced kinds are very generally worn in Suffolk, where hemp is cultivated, by husbandmen, farmers, &c.; those from 1s. 6d. to 2s. 4s. 6d. are frequently preferred by gentlemen to flax-linen.

Annals of
Agriculture, vol.
xiii. p. 508.

Annals of
Agriculture.

linen, on account of their strength and warmth. The English hemp is much superior in strength to that which grows in any other country. Next to it is the Russian, from which sacking is usually made, as it is sometimes also from the flax of the English kind; but none of the Suffolk hemp is ever made into cordage, on account of its fineness. A considerable quantity of Russia sheeting is imported into England merely on account of its strength, and is much coarser at the price than any other foreign linen.

Besides these uses of hemp, it is said to possess a property as a plant which renders it almost invaluable; viz. that of driving away almost all insects that feed upon other vegetables. Hence in some places of the continent they secure their crops from these mischievous attacks, by sowing a belt of hemp round their gardens, or any particular spot which they wish to preserve.

The important uses of hemp, and the superiority of that produced in Britain to other kinds, have rendered the culture of it an object of attention to government. Accordingly, in the year 1787, a bounty of threepence per stone was allowed on all the hemp raised in England; and probably with a view to encourage the growth of English hemp, duties have been laid on that which comes from abroad. Dressed hemp in a British ship pays 2l. 4s. per cwt. import duty; in a foreign one 2l. 6s. 9d.; and in both cases a drawback of 1l. 19s. is allowed. Undressed hemp in a British ship pays 3s. 8d.; and in a foreign one 3s. 11d. In both cases the drawback is 3s. 4d. The export of British hemp is free.

The usual height of the plant when growing is from five to six feet, but this varies very considerably according to circumstances. That which is cultivated near Bischwiller in Alsace is sometimes more than 12 feet high, and upwards of three inches in circumference, the stalks being so deeply rooted that a very strong man can scarce pull them up. Mr Arthur Young, in a tour through Catalonia in Spain, says, that where the country is well watered, the crops of hemp are extraordinary; and that the plants generally rise to the height of seven feet. In Italy hemp is generally cultivated, though the Bolognese only can pretend to any superiority in the management of it. It is there sown upon their best lands, which are rich strong loams; and on which they are at all possible pains to procure a fine friable surface. For manure they use dung, pieces of rotten cloth, feathers, and horns brought from Dalmatia. The plant, however, may be cultivated upon ground of every kind; the poorer land producing that which is finer in quality though in smaller quantity; whereas strong and rich land produces a great quantity but coarser. It does not exhaust the land on which it grows like flax; whence it is probable, that if properly managed, and care taken in the cultivation, it might be found to supersede flax entirely. A Sussex manufacturer, who writes on this subject in the Annals of Agriculture, informs us, that it may be raised for many years successively on the same ground, provided it be well manured. An acre requires from nine to twelve pecks, according to the nature of the soil; the latter being the most usual, though a variation in the quality of the soil makes an alteration both in the quantity and quality of the

hemp. An acre produces on an average 36 or 38 stone. The abbé Brulle, in a treatise upon the Cultivation and Management of Hemp, printed by order of the lords of the committee of council for trade and foreign plantations, informs us, that the season for sowing it extends from the 25th of March to the 15th of June. The seed ought always to be sown thin, not exceeding two bushels to an acre; and if you have the advantage of a drill plough, still less will answer. As there are two kinds of hemp, the male and female, of which the former only produces seed, some regard must be had to this circumstance. In Sussex the male and female are pulled together about 13 weeks after the sowing, but in the fens they are frequently separated. This last method is recommended by the abbe Brulle, who, for the more easy accomplishment of it, directs that little paths should be made lengthwise through the field at about seven feet distance from each other, to allow a passage for the person who pulls up the female hemp from among the other; the latter requiring to stand more than a month after for the purpose of ripening the seeds. The female hemp is known to be ripe by the fading of the flowers, the falling of the farina fecundans, and some of the stalks turning yellow. After the whole of this kind is pulled, it must be manufactured according to the directions to be afterwards given, and ought to be worked if possible while green; the hemp thus produced being much finer than that which is previously dried. The reason of this is, that the plant contains a great quantity of glutinous matter; which being once dried, agglutinates the fibres in such a manner that they can never be afterwards perfectly separated. The female hemp, however, is always in smaller quantity than the male; and therefore where the crop is large, it will be impossible to work the whole as fast as it is pulled or cut. It is known to be ripe by the stems becoming pale; but it must be remembered, that hemp of any kind will be much less injured by pulling the plants before they are ripe, than by letting them stand too long.

The male hemp being stripped of its leaves, &c. as afterwards directed, will soon be dry for storing by the heat of the atmosphere, though sometimes it may be necessary to use artificial means; but where these are used, the utmost care must be taken, hemp when dry, being exceedingly inflammable. The stored or dried hemp must be steeped and treated in every other respect as though it had been green; whence it is evident that this operation ought never to be used but in cases of necessity. It is likewise impossible to make hemp which has been dried previous to its being steeped so white as that which has been worked green.

With regard to the perfecting of hemp-seed for a subsequent season, it would seem proper to set apart a piece of ground for this purpose: for M. Amien, from vol. v. 40 plants raised in the common way, had only a pound and a half of seed, though the plants from which it was taken might be deemed fine; whereas, from a single plant which grew by itself, he had seven pounds and a half. Some are of opinion, that by putting the clusters which contain the hemp-seed to heat and sweat, the quality is improved; as many of those seeds which would otherwise wither and die may thus arrive at perfection. This, however, seems to be very problematical; as there are no experiments which show that seeds

Hemp. when separated from the vegetable producing them, have any power of meliorating themselves.

After the hemp is pulled, it must be taken in large handfuls, cutting off the roots (though this is not absolutely necessary), the leaves, seeds, and lateral branches, being dressed off with a wooden sword or ripple. It is then to be made up into bundles of twelve handfuls each, in order to be steeped, like flax, in water. This, or something similar, is absolutely necessary, in order to separate the bark; which is properly the hemp, from the reed or woody part. In Suffolk this operation is called *water-retting*; but sometimes a mere exposure to the air is substituted in its place, turning the hemp frequently during the time it is exposed. This is called *dew-retting*; but the former method is universally deemed preferable. Such hemp as is designed for seed is seldom water-retted, though in the opinion of the manufacturer already quoted, it would be better if it were so. Dew-retted hemp is generally stacked and covered during the winter: in January and February it is spread upon meadow land, and whitens with the frost and snow; though it is always much inferior to the other, and proper for coarser yarns only.

The length of time required for steeping hemp is various, and a complete knowledge of it can only be attained by practice. In Suffolk it is usual to continue the immersion, four, five, or six days; standing water is preferred, and the same water will steep hemp three times during the season, but the first has always the best colour. The abbé Brulle prefers clear and running water, especially if overhung with trees. The bundles are to be laid crosswise upon each other, taking particular notice of the manner in which they lie when put in, that they may be taken out without difficulty. His time of steeping is from six to 11 days; and here we must observe, that it is much better to let it remain too long in the water than too short a time. The slenderest hemp requires the most soaking. The operation is known to be finished by the reed separating easily from the bark.

After the hemp is thoroughly steeped, the next operation is to separate the bark from the reed or woody part; and this may be done in two ways, viz. either pulling out the reed from every stalk with the hand, or drying and breaking it like flax. The abbé Brulle is very particular in his directions for this last operation, which he calls *reading*, and which may be performed either in a trough under water or upon a table. The whole, however, may be reduced to the following, viz. pressing down the bundles either in the trough or on a table by proper weights, to keep the hemp steady in the middle and top end. Then beginning at the upper parts of the bundle, pull out the reeds one by one. As you proceed, the rind which remains will press closely upon the remaining unreeded hemp, and keep it more steady; so that you may take two, four, or even six stalks, at a time. The weight is then to be removed from the top, and all the pieces of reed which remain there having broken off in the former operation, are to be taken out. Lastly, the middle weight is to be taken off, and any small pieces which remain there taken out. If the reeding is performed on a table, the bundle must be weeded frequently, though slightly; a continual dropping of water would perhaps be the best method.

After the hemp is reeded, it must next be freed from the mucilaginous matter with which it still abounds. This is done by pouring water through it, squeezing out the liquid after every affusion, but taking care not to let the threads twist or entangle each other, which they will be very apt to do. The abbé is of opinion, that soft soap should be dissolved in the last water, in the proportion of an ounce to three pounds of dry hemp; which though not absolutely necessary, contributes much to the softening and rendering the hemp easy and pleasant to dress.

Hemp is broken by machinery, after being steeped, in a manner similar to flax; but the instruments used for this purpose in Suffolk are all worked by the hand. That which breaks in the operation is called *shorts*, and is about half the value of the long hemp. The best water-retted hemp sells for about 8s. 6d. per stone; the other kind from one to two shillings lower.

Beating of hemp is the next operation, which formerly was performed entirely by hand, but now in most places by a water-mill, which raises three heavy beaters that fall upon it alternately; the hemp being turned all the while by a boy in order to receive the strokes equally. The finer it is required to make the tow, the more beating is necessary. It is then dressed or combed by drawing it through heckles formed like the combs of wool manufacturers, only fixed. Sometimes it is divided into two or three sorts of tow, and sometimes the whole is worked together into one sort; the prices varying from 6d. to 1s. per pound.

The hemp thus manufactured is sold to spinners, who reel their yarn as follows.

2 yards make	-	1 thread.
40 threads	-	1 lea.
20 leas	-	1 skain.
3 skains	-	1 cluc of 4800 yards.

It is next delivered to the bleachers, who return it bleached on receiving 20 or 21 clues for every 120 bleached. The prices of the hemp-yarn are as follow:

1 cluc from a pound	7d. or 6 $\frac{1}{2}$ d.
1 $\frac{1}{2}$ from do.	8 $\frac{1}{2}$ d. or 8d.
2 from do.	9 $\frac{1}{2}$ d. or 9d.
2 $\frac{1}{2}$ from do.	10 $\frac{1}{2}$ d. or 10d.
3 from do.	12d.

Chinese HEMP, a species of cannabis, of which an account is given in the 72d volume of the Philosophical Transactions, p. 46. In that paper Mr Fitzgerald, vice-president of the society for encouraging arts, mentions his having received the seeds from the late Mr Elliot; which being sown, according to his directions, produced plants 14 feet high, and nearly seven inches in circumference. These being pulled up in November, and steeped for a fortnight in water, were placed against a southern wall to dry. After this the hemp was found to separate easily from the woody part; and so great was the produce, that 32 plants yielded three pounds and a quarter. In consequence of this success, Mr Fitzgerald applied to the directors of the India Company to procure some of the seeds from China; which being complied with, the society were furnished, in 1785, with some more of the seeds, which were distributed

buted to several of the members; but, notwithstanding their endeavours, few of the plants appear to have ripened their seeds in this country. Two of the species of hemp, tried by the duke of Northumberland, rose to the height of 14 feet seven inches, and would have been much larger, had they not been hurt by a high wind: another kind arose only to that of three feet and a half, the stem about the size of a common wheat straw; but though it flowered well, did not produce any seed. These kinds were sown in a hot-bed where the heat was very strong, on the 14th of April. They appeared above ground in four days, and were transplanted into pots on the 25th. They were then put under a hot-bed frame where the heat had been gone off, to harden them for the natural ground, in which they were planted on the 30th, by turning them whole out of the pots; letting them, three together, be planted at two feet distance every way; covering them at times for about ten days, until they were supposed to be rooted. Only a few seeds were preserved from plants which had been kept constantly in a stove.

Other trials were attended with little better success; but, in 1789, the Rev. Dr Hinton of Northwold near Brandon, made a successful experiment with some seeds he received from the secretary of the society. They were sown on the 17th of May, and appeared on the 6th of June. The plants were few and sickly; and notwithstanding some fine showers, they continued to languish so much that the experiment was entirely abandoned, and buckwheat was harrowed into the ground for a fallow crop. In the beginning of October, however, the persons employed in cutting the buckwheat discovered some seed in the heads of a few straggling hemp plants which had been suffered to grow in the crop; which being carefully threshed, afforded three pints of seed tolerably bright and heavy. These seeds were sown on the 10th of May 1787. On the 19th they appeared above the ground numerous and healthy. The male hemp was drawn on the 13th of August, but the female not till the 9th of October; the spot on which the plants were sown measured only 322 square yards, and produced of marketable hemp no less than 95 stone 7 pounds 12 ounces; being upwards of one-third more than the best crops of English hemp are ever known to produce. Thus it appeared, that the seeds of the Chinese hemp had retained their superiority over those of the English; though how long they would continue to do so cannot be determined but by experience. From this experiment Dr Hinton received a silver medal from the society. Few of the seeds either of Chinese, or any other hemp, will vegetate if two years old at the time of sowing; and to this circumstance the doctor attributes the failure of other trials of Chinese hemp.

HEMP-AGRIMONY, a species of eupatorium. See *EUPATORIUM*, BOTANY *Index*.

HEMPSTEAD, a town of Hertfordshire in England, in a hilly country, upon a small river called the Gade, and 20 miles north-west of London. It was, in the time of the Saxons, called by the name of Henamsted, or Hean-Hemsted, i. e. High-Hemstead; in William the Conqueror's time, by the name of Heme-lamstede. Henry VIII. incorporated this village by the name of a bailiff; and he empowered the inhabitants to have a common seal, and a pye-powder court

during its market and fairs. It has been reckoned one of the greatest markets for wheat in this county, if not in England. Eleven pair of mills stand within four miles of the place, which produce a great trade. Population 3240 in 1811.

HEMSKERCK, **EGBERT**, called the *Old*, a celebrated Flemish painter of humorous conversations, of whom, though so universally known, we have no information as to the time in which he flourished, or the school in which he was taught. Though the taste of his compositions is but low, yet it ought to be considered that he took his subjects from nature; from persons in the meanest occupations, whose dress, actions, and manners, could not furnish the imagination with any ideas of elegance: and to express their passions and undigested humours, seems to have been the utmost of his ambition. By frequenting fairs, merry-meetings, gaming-houses, and inns, he acquired a surprising power of connecting humorous circumstances. He designed and drew correctly, and his pictures have a strong effect from his accurate management of the chiaro oscuro. Some of his pictures have suffered from unskilful cleaners, and many things are sold as his which dishonour him; but his genuine works, well preserved, have a clearness and force equal to any of the Flemish artists.

HEN. See *PHASIANUS*, ORNITHOLOGY *Index*.

Guinea-HEN. See *NUMIDA*, ORNITHOLOGY *Index*.

HEN-Bane. See *HYOSCIAMUS*, BOTANY and *MATERIA MEDICA Index*.

HEN-HARRIER. See *FALCO*, ORNITHOLOGY *Index*.

HEN-Mould Soil, in *Agriculture*, a term used by the husbandmen in Northamptonshire, and other counties, to express a black, hollow, spongy, and mouldering earth, usually found at the bottom of hills. It is an earth much fitter for grazing than for corn, because it will never settle close enough to the grain to keep it sufficiently steady while it is growing up, without which, the farmers observe, it either does not grow well; or, if it seem to thrive, as it will in some years, the growth is rank, and yields much straw, but little ear. It is too moist, and to that is principally to be attributed this rankness of the crop in some years; and the occasion of its retaining so much moisture is, that it usually has a bed of stiff clay, which will not let the water run off into the under strata.

In some places they also give this name to a black, rich, and dense earth, with streaks of a whitish mould in many parts. This sort of hen-mould is usually found very rich and fertile.

HENAULT, **CHARLES JOHN FRANCIS**, an ingenious French writer, was the son of John Remi Henault lord of Moussy, and was born at Paris in 1685. He early discovered a sprightly benevolent disposition, and his penetration and aptness soon distinguished itself by the success of his studies. Claude de Lisle, father of the celebrated geographer, gave him the same lessons in geography and history which he had before given to the duke of Orleans, afterwards regent; and which have been printed in seven volumes, under the title of "Abridgement of Universal History." On quitting college, Henault entered the Oratory, where he soon attached himself to the study of eloquence; and, on the death of the abbé Rene, reformer of La Trappe, he undertook to pronounce his panegyric; which not meet-

Hempstead
Henault.

Henault. ing the approbation of Father Massilon, he quitted the Oratory after two years, and his father bought for him, of Mareschal Villeroy, the "lieutenancy des chasses," and the government of Corbeil. At the marshal's he formed connexions, and even intimate friendships, with many of the nobility, and passed the early part of his life in agreeable amusements, and in the liveliest company, without having his religious sentiments tainted. He associated with the wits till the dispute between Rousseau and de la Motte soon gave him a disgust for these trifling societies. In 1707, he gained the prize of eloquence at the French academy; and another next year at the academy des Jeux Floraux. About this time M. Reaumur, who was his relation, came to Paris, and took lessons in geometry under the same master, Guinée. Henault introduced him to the abbé Bignon, and this was the first step of his illustrious course. In 1713 he brought a tragedy on the stage, under the disguised name of Fuselier. As he was known to the public only by some slighter pieces, "Cornelia the Vestal" met with no better success. He therefore locked it up without printing. In his old age his passion for these subjects reviving, and Mr Horace Walpole being at Paris in 1768, and having formed a friendship with him as one of the most amiable men of his nation, obtained this piece, and had it printed at his own press. In 1751 M. Henault, under a borrowed name, brought out a second tragedy, intitled, "Marius," which was well received and printed. He had been admitted counsellor in parliament in 1706, with a dispensation on account of age; and in 1710 president of the first chamber of inquests. These important places, which he determined to fill in a becoming manner, engaged him in the most solid studies. The excellent work of M. Domat charmed him, and made him eager to go back to the fountain head. He spent several years in making himself master of the Roman law, the ordonnances of the French kings, their customs, and public law. M. de Morville, procureur-general of the great council, being appointed ambassador to the Hague in 1718, engaged M. Henault to accompany him. His personal merit soon introduced him to the acquaintance of the most eminent personages at that time there. The grand pensionary, Heinsius, who, under the exterior of Lacedæmonian simplicity, kept up all the haughtiness of that people, lost with him all that hauteur which France itself had experienced from him in the negociations of the treaty of Utrecht. The agitation which all France felt by Law's system, and the consequent sending of the parliament into exile, was a trial to the wise policy of the president Henault. His friendship for the first president, De Mesmes, led him to second all the views of that great magistrate: he took part in all the negociations, and was animated purely by the public good, without any private advantage. On the death of the cardinal du Bois, in 1732, he succeeded in his place at the French academy. Cardinal Fleury recommended him to succeed himself as director, and he pronounced the eulogy of M. de Malezieux.

History was M. Henault's favourite study: not a bare collection of dates, but a knowledge of the laws and manners of nations; to obtain which he drew instruction from private conversations, a method he so strongly recommends in his preface. After having thus discussed the most important points of our public law,

he undertook to collect and publish the result of his inquiries, and he is deservedly accounted the first framer of chronological abridgements: in which, without stopping at detached facts, he attends only to those which form a chain of events that perfect or alter the government and character of a nation, and traces only the springs which exalt or humble a nation, extending or contracting the space it occupies in the world. His work has had the fortune of those literary phenomena, where novelty and merit united excite minds eager after glory, and fire the ardour of young writers to press after a guide whom few can overtake. The first edition of the work, the result of 40 years' reading, appeared in 1744, under the auspices of the chancellor Daguesseau, with the modest title of *an Essay*. The success it met with surprised him. He made continual improvements in it, and it has gone through nine editions, and been translated into Italian, English, and German, and even into Chinese. As the best writings are not secure from criticism, and are indeed the only ones that deserve it, the author read to the academy of Belles Lettres a defence of his abridgement. All the ages and events of the French monarchy being present to his mind, and his imagination and memory being a vast theatre whereon he beheld the different movements and parts of the actors in the several revolutions, he determined to give a specimen of what passed in his own mind, and to reduce into the form of a regular drama one of the periods of French history, the reign of Francis II. which, though happy only by being short, appeared to him one of the most important by its consequences, and most easy to be confined within the stage bounds. His friend the chancellor highly approved the plan, and wished it to be printed. It accordingly went through five editions; the harmony of dates and facts is exactly observed in it, and the passions interested without offence to historic truth.

In 1755, he was chosen an honorary member of the academy of Belles Lettres, being then a member of the academies of Nanci, Berlin, and Stockholm. The queen appointed him superintendent of her house. His natural sprightliness relieved her from the serious attendance on his private morning lectures. The company of persons most distinguished by their wit and birth, a table more celebrated for the choice of the guests than its delicacies, the little comedies suggested by wit, and executed by reflections, united at his house all the pleasures of an agreeable and innocent life. All the members of this ingenious society contributed to render it agreeable, and the president was not behind any. He composed three comedies: *La Petite Maison*, *La Jaloux de Soi-meme*, and *La Reveil d'Epimenide*. The subject of the last was the Cretan philosopher, who is pretended to have slept 27 years. He is introduced fancying that he had slept but one night, and astonished at the change in the age of all around him: he mistakes his mistress for his mother; but discovering his mistake, offers to marry her, which she refuses, though he still continues to love her. The queen was particularly pleased with this piece. She ordered the president to restore the philosopher's mistress to her former youth: he introduced Hebe, and this episode produced an agreeable entertainment. He was now in such favour with her majesty, that on the place of superintendent becoming vacant by the death of M. Bernard de Con-

enault
Henley.

bert master of requests, and the sum he had paid for it being lost to his family, Henault solicited it in favour of several persons, till at last the queen bestowed it on himself, and consented that he should divide the profits with his predecessor's widow. On the queen's death he held the same place under the dauphiness.

A delicate constitution made him liable to much illness; which, however, did not interrupt the serenity of his mind. He made several journeys to the waters of Plombieres: in one of these he visited the deposed king Stanislaus at Luneville; and in another accompanied his friend the marquis de Pauliny, ambassador to Switzerland. In 1763 he drew near his end. One morning, after a quiet night, he felt an oppression, which the faculty pronounced a suffocating cough. His confessor being sent to him, he formed his resolution without alarm. He has since said, that he recollected having then said to himself, "What do I regret?" and called to mind that saying of Madame de Sevigne, "I leave here only dying creatures." He received the sacraments. It was believed the next night would be his last; but by noon next day he was out of danger. "Now (said he) I know what death is. It will not be new to me any more." He never forgot it during the following seven years of his life, which, like all the rest, were gentle and calm. Full of gratitude for the favours of providence, resigned to its decrees, offering to the Author of his being a pure and sincere devotion; he felt his infirmities without complaining, and perceived a gradual decay with unabated firmness. He died Dec. 24. 1771, in his 86th year. He married in 1714 a daughter of M. le Bas de Montargis keeper of the royal treasure, &c. who died in 1728 without leaving any issue.

HENDECAGON, in *Geometry*, a figure having eleven sides and as many angles.

HENED-PENNY, in our old writers, a customary payment of money, instead of hens at Christmas. It is mentioned in a charter of King Edward III. Mon. Angl. tom. ii. p. 327. Du Cange is of opinion it may be *hen-penny*, *gallinagium*, or a composition for eggs; but Cowel thinks it is misprinted *hened-penny* for *heved-penny* or *headpenny*.

HENIOCHAS, or **HENIOCHUS**, a northern constellation, the same as *Auriga*.

HENLEY, a town of Oxfordshire in England, seated on the river Thames, over which there is a handsome bridge. It sends malt, corn, and other things, to London in barges. W. Long. o. 40. N. Lat. 51. 34.

HENLEY, a town of Warwickshire in England, seated on the river Aine, in W. Long. o. 40. N. Lat. 52. 18.

HENLEY, *John*, better known by the appellation of *Orator Henley*, a very singular character, was born at Melton-Moubray, Leicestershire, in 1691. His father, the Rev. Simon Henley, and his grandfather by his mother's side (John Dowel, M. A.), were both vicars of that parish. Having passed his exercises at Cambridge, and his examination for the degree of B. A. with the particular approbation of Mr Field, Mr Smales, and the master of the college, he returned to his native place, where he was first desired by the trustees of the school in Melton to assist in, and then to take the direction of, that school; which he increased and raised

from a declining to a flourishing condition. He established here a practice of improving elocution by the public speaking of passages in the classics, morning and afternoon, as well as orations, &c. Here he was invited by a letter from the Rev. Mr Newcombe to be a candidate for a fellowship in St John's; but as he had long been absent, and therefore lessened his personal interest, he declined appearing for it. Here likewise he began his "Universal Grammar," and finished ten languages, with dissertations prefixed, as the most ready introduction, to any tongue whatever. In the beginning of this interval he wrote his poem on "Esther," which was approved by the town, and well received. He was ordained a deacon by Dr Wake, then bishop of Lincoln; and after having taken his degree of M. A. was admitted to priest's orders by Dr Gibson, his successor at that see. He formed an early resolution to improve himself in all the advantages of books and conversation the most effectually, on the first opportunity, at London. But he laid the basis of future proficiency in assisting at the curacy of his native town; where he preached many occasional sermons, particularly one at the assizes at Leicester; he then gave a voluntary warning for the choice of a new master and curate, and came to town recommended by above 30 letters from the most considerable men in the country, both of the clergy and laity; but against the inclination of his neighbours and his school, which was now, as from his first entrance upon it, still advancing: and his method being established and approved, one of his own scholars was appointed to succeed him.—In town he published several pieces, as a translation of Pliny's Epistles, of several works of Abbé Vertot, of Montfaucon's Italian Travels in folio, and many other lucubrations. His most generous patron was the earl of Macclesfield, who gave him a benefice in the country, the value of which to a resident would have been above 80l. a year; he had likewise a lecture in the city; and preached more charity sermons about town, was more numerously followed, and raised more for the poor children, than any other preacher, however dignified or distinguished. But when he pressed his desire and promise from a great man of being fixed in town, it passed in the negative. He took the people (it seems) too much from their parish-churches; and as he was not so proper for a London divine, he was very welcome notwithstanding all difficulties, to be a rural pastor. But it was not for a second rustication, as he informs us*; that he left the fields and the swains of Arcadia to visit the great city: and as he knew it was as lawful to take a license from the king and parliament at Hicks's-hall as at Doctors Commons (since the ministerial powers of this kingdom are and ought to be parliamentary only), he freely, without compulsion, or being desired or capable of being compelled to reside in the country, gave up his benefice and lecture, certainties for an uncertainty; believing the public would be a more hospitable protector of learning and science, than some of the upper world in his own order.

Mr Henley, in answer to a cavil (that he borrowed from books), proposed, "that if any person would single out any celebrated discourse of an approved writer, dead or living, and point out what he thought excellent in it, and the reasons; he would submit it to the world, whether the most famed composition might not

Henley.

Ordinary,
Transact.
as lawful to take a license from the king and parliament, &c.

Henley be surpassed in their own excellency, either on that or any different subject."

Henley preached on Sundays upon theological matters, and on Wednesdays upon all other sciences. He declaimed some years against the greatest persons, and occasionally, says Warburton, did Pope that honour. The poet in return thus blazons him to infamy:

But where each science lifts its modern type,
History her pot, Divinity his pipe,
While proud Philosophy repines to show,
Dishonest sight! his breeches rent below;
Imbrown'd with native bronze, lo Henley stands,
Tuning his voice, and balancing his hands.
How fluent nonsense trickles from his tongue!
How sweet the periods, neither said nor sung!
Still break the benches, Henley! with thy strain,
While Kennet, Hare, and Gibson preach in vain.
O great restorer of the good old stage,
Preacher at once and zany of thy age!
O worthy thou of Ægypt's wise abodes,
A decent priest where monkeys were the gods!
But Fate with butchers plac'd thy priestly stall,
Meek modern faith to murder, back, and maul:
And bade thee live to crown Britannia's praise,
In Toland's, Tindal's, and in Woolston's days."

This extraordinary person (who died October 14. 1756) struck medals, which he dispersed as tickets to his subscribers: a star rising to the meridian, with this motto, *Ad summa*; and below, *Inveniam viam, aut faciam*. Each auditor paid 1s. He was author of a weekly paper called the *Hyp Doctor*, for which he had 100l. a-year. Henley used every Saturday to print an advertisement in the *Daily Advertiser*, containing an account of the subjects he intended to discourse on the ensuing evening at his oratory near Lincoln's-inn-fields, with a sort of motto before it, which was generally a sneer at some public transaction of the preceding week. Dr Cobden, one of Geo. II.'s chaplains, having, in 1748, preached a sermon at St James's from these words, "Take away the wicked from before the king, and his throne shall be established in righteousness;" it gave so much displeasure, that the Doctor was struck out of the list of chaplains; and the next Saturday the following parody of his text appeared as a motto to Henley's advertisement:

Away with the wicked before the king,
And away with the wicked behind him;
His throne it will bless
With righteousness,
And we shall know where to find him."

His audience was generally composed of the lowest ranks; and it is well known that he even collected an infinite number of shoe-makers, by announcing that he could teach them a speedy mode of operation in their business, which proved only to be, the making of shoes by cutting off the tops of ready-made boots.

HENNA, or ALHENNA. See LAWSONIA.

HENNEBERG, a county of Germany, in the circle of Franconia; is bounded on the north by Thuringia, on the west by Hesse, on the south by the bishoprick of Wertsburg, and on the east by that of Bamberg; abounds in mountains and woods; and is populous and fertile. Mainingen is the capital town.

HENNEBERG, a town of Germany, in the circle of Franconia, which gives title to a county of the same name, with a castle. E. Long. 9. 17. N. Lat. 50. 40.

HENNEBON, a town of France, in the department of Morbihan, and situated on the river Blavet. It enjoys a considerable trade, and contains 4600 inhabitants. It is 62 miles west from Paris, in W. Long. 3. 11. N. Lat. 47. 48.

HENOTICUM, (*Hœnoticus*, q. d. "reconciliative;" of *hœno*, "I unite"), in church history, a famous edict of the emperor Zeno, published A. D. 482, and intended to reconcile and reunite the Eutychians with the Catholics. It was procured of the emperor by means of Acacius, patriarch of Constantinople, with the assistance of the friends of Peter Mongus and Peter Trullo. The sting of this edict lies here; that it repeats and confirms all that had been enacted in the councils of Nice, Constantinople, Ephesus, and Chalcedon, against the Arians, Nestorians, and Eutychians, without making any particular mention of the council of Chalcedon. It is in form of a letter, addressed by Zeno to the bishops, priests, monks, and people of Egypt and Libya. It was opposed by the Catholics, and condemned in form by Pope Felix II.

HENRICANS, in ecclesiastical history, a sect so called from Henry its founder, who, though a monk and hermit, undertook to reform the superstition and vices of the clergy. For this purpose he left Lausanne in Switzerland, and removing from different places, at length settled at Thoulouse in the year 1147, and there exercised his ministerial function, till being overcome by the opposition of Bernard abbot of Clairval, and condemned by Pope Eugenius III. at a council assembled at Rheims, he was committed to a close prison in 1148, where he soon ended his days. This reformer rejected the baptism of infants; severely censured the corrupt manners of the clergy; treated the festivals and ceremonies of the church with the utmost contempt, and held clandestine assemblies for inculcating his peculiar doctrines.

HENRY, or CAPE-HENRY, the south cape of Virginia, at the entrance of Chesapeak bay. W. Long. 74. 50. N. Lat. 37. 0.

HENRY, the name of several emperors of Germany, and kings of England and France. See ENGLAND, FRANCE, and GERMANY.

HENRY IV. emperor of Germany in 1056, styled *the Great*, was memorable for his quarrels with Pope Gregory II. whom at one time he deposed, for having presumed to judge his sovereign; but at another, dreading the effects of the papal anathemas, he had the weakness to submit to the most humiliating personal solicitations and penances to obtain absolution; which impolitic measure increased the power of the pope, and alienated the affections of his subjects: thus circumstanced, he reassumed the hero, but too late; marched with an army to Rome, expelled Gregory, deposed him, and set up another pope. Gregory died soon after: but Urban II. and Pascal II. successively, excited his ambitious sons, Conrad and Henry, to rebel against him, and the latter was crowned emperor by the title of Henry V. in 1106; and he had the inhumanity to arrest his father, and to de-

prive.

curry. Henry.
 prive him, not only of all his dignities, but even of the necessaries of life. The unfortunate Henry IV. was reduced to such extremities (after having fought 62 battles in defence of the German empire), that he solicited the bishop of Spire to grant him an under-chaunter's place in his cathedral, but was refused. He died in the same year at Liege, aged 35, a martyr to the ignorance and superstition of the age, and to his own blind confidence in favourites and mistresses.

HENRY IV. king of France (in 1589) and Navarre, justly styled *the Great*, was the son of Anthony de Bourbon, chief of the branch of Bourbon (so called from a fief of that name which fell to them by marriage with the heiress of the estate). His mother was the daughter of Henry d'Albert, king of Navarre; a woman of masculine genius; intrepid, simple, and rustic in her manners, but deeply versed in politics, and a zealous Protestant. Foreseeing that her party would want such a protector (for her husband was a weak indolent prince), she undertook the care of the education of the young hero: his diet was coarse; his clothes neat, but plain; he always went bare-headed; she sent him to school with the other children of the same age, and accustomed him to climb the rocks and neighbouring mountains, according to the custom of the country. He was born in 1553; and in 1569, the 16th year of his age, he was declared the Defender and Chief of the Protestants at Rochelle. The peace of St Germain, concluded in 1570, recalled the lords in the Protestant interest to court; and in 1572 Henry was married to Margaret de Valois, sister to Charles IX. king of France. It was in the midst of the rejoicings for these nuptials that the horrid massacre of Paris took place. Henry was reduced, by this infernal stroke of false policy, to the alternative of changing his religion or being put to death: he chose the former, and was detained prisoner of state three years. In 1587 he made his escape; put himself at the head of the Huguenot party, exposing himself to all the risks and fatigues of a religious war, often in want of the necessaries of life, and enduring all the hardships of the common soldiers; but he gained a victory this year at Courtras, which established his reputation in arms, and endeared him to the Protestants. On the death of Henry III. religion was urged as a pretext for one half of the officers of the French army to reject him, and for the leaguers not to acknowledge him. A phantom, the cardinal de Bourbon, was set up against him; but his most formidable rival was the duke de Mayenne: however, Henry, with few friends, fewer important places, no money, and a very small army, supplied every want by his activity and valour. He gained several victories over the duke; particularly that of Ivry in 1590, memorable for his heroic admonition to his soldiers: "If you love your ensigns, rally by my white plume; you will always find it in the road to honour and glory." Paris held out against him, notwithstanding his successes: he took all the suburbs in one day; and might have reduced the city by famine, if he had not humanely suffered his own army to relieve the besieged; yet the bigotted friars and priests in Paris all turned soldiers, except four of the Mendicant order; and made daily military reviews and processions, the sword in one hand and the crucifix in the other, on which they made the citizens

swear rather to die with famine than to admit Henry. The scarcity of provisions in Paris at last degenerated to an universal famine; bread had been sold, whilst any remained, for a crown the pound, and at last it was made from the bones of the charnel-house of St Innocents; human flesh became the food of the obstinate Parisians, and mothers ate the dead bodies of their children. In fine, the duke of Mayenne, seeing that neither Spain nor the league would ever grant him the crown, determined to assist in giving it to the lawful heir. He engaged the states to hold a conference with the chiefs of both parties; which ended in Henry's abjuration of the Protestant religion at St Dennis, and his consecration at Chartres in 1593. The following year Paris opened its gates to him; in 1596, the duke of Mayenne was pardoned; and in 1598, peace was concluded with Spain. Henry now showed himself doubly worthy of the throne, by his encouragement of commerce, the fine arts, and manufactures, and by his patronage of men of ingenuity and sound learning of every country: but though the fermentations of Romish bigotry were calmed, the leaven was not destroyed; scarce a year passed without some attempt being made on this real father of his people; and at last the monster Ravailac stabbed him to the heart in his coach, in the streets of Paris, on the 14th of May 1610, in the 57th year of his age and 22d of his reign.

HENRY VIII. king of England, was the second son of Henry VII. by Elizabeth the eldest daughter of Edward IV. He was born at Greenwich, on the 28th of June 1491. On the death of his brother Arthur, in 1502, he was created prince of Wales; and the following year betrothed to Catharine of Aragon, Prince Arthur's widow, the pope having granted a dispensation for that purpose. Henry VIII. ascended the throne, on the death of his father, the 22d of April 1509, and his marriage with Catharine was solemnized about two months after. In the beginning of his reign he left the government of his kingdom entirely to his ministers; and spent his time chiefly in tournaments, balls, concerts, and other expensive amusements. We are told that he was so extravagant in his pleasures, that, in a very short time, he entirely dissipated 1,800,000l. which his father had hoarded. This will seem less wonderful, when the reader is informed, that gaming was one of his favourite diversions. Nevertheless he was not so totally absorbed in pleasure, but he found leisure to sacrifice to the resentment of the people two of his father's ministers, Empson and Dudley. A house in London, which had belonged to the former of these, was in 1510 given to Thomas Wolsey, who was now the king's almoner, and who from this period began to insinuate himself into Henry's favour. In 1513, he became prime minister, and from that moment governed the king and kingdom with absolute power. In this year Henry declared war against France, gained the battle of Spurs, and took the towns of Terouenne and Tournay; but before he embarked his troops, he beheaded the earl of Suffolk, who had been long confined in the Tower. In 1521, he sacrificed the duke of Buckingham to the resentment of his prime minister Wolsey, and the same year obtained from the pope the title of *Defender of the Faith*.

Henry.

Henry, having been 18 years married, grew tired of his wife, and in the year 1527 resolved to obtain a divorce; but after many fruitless solicitations, finding it impossible to persuade the pope to annul his marriage with Catharine, he espoused Anne Boleyn in the year 1531. During this interval his favourite Wolsey was disgraced, and died; Henry threw off the papal yoke, and burnt three Protestants for heresy. In 1535, he put to death Sir Thomas Moore, Fisher, and others, for denying his supremacy, and suppressed all the lesser monasteries.

His most sacred majesty, having now possessed his second queen about five years, fell violently in love with Lady Jane Seymour. Anne Boleyn was accused of adultery with her own brother, and with three other persons: she was beheaded the 19th of May 1536. He married Jane Seymour the day following. In 1537, he put to death five of the noble family of Kildare, as a terror to the Irish, of whose disloyalty he had some apprehensions; and in the year following he executed the marquis of Exeter, with four other persons of distinction, for the sole crime of corresponding with Cardinal Pole. In 1538 and 1539, he suppressed all the monasteries in England, and seized their revenues for his own use. The queen having died in child-bed, he this year married the princess Ann of Cleves: but disliking her person, immediately determined to be divorced; and his obsequious parliament and convocation unanimously pronounced the marriage void, for reasons too ridiculous to be recited: but this was not all; Henry was so incensed with his minister and quondam favourite, Cromwell, for negotiating this match, that he revenged himself by the hand of the executioner. Yet this was not the only public murder of the year 1540. A few days after Cromwell's death, several persons were burnt for denying the king's supremacy, and other articles of heresy.

His majesty being once more at liberty to indulge himself with another wife, fixed upon Catharine Howard, niece to the duke of Norfolk. She was declared queen in August 1540; but they had been privately married some time before. Henry, it seems, was so entirely satisfied with this lady, that he daily blessed God for his present felicity; but that felicity was of short duration: he had not been married above a year, before the queen was accused of frequent prostitution, both before and since her marriage: she confessed her guilt, and was beheaded in February 1542. In July 1543, he married his sixth wife, the lady Catharine Parr, the widow of John Nevil Lord Latimer, and lived to the year 1547 without committing any more flagrant enormities: but finding himself now approach towards dissolution, he made his will; and that the last scene of his life might resemble the rest, he determined to end the tragedy with the murder of two of his best friends and most faithful subjects, the duke of Norfolk and his son the earl of Surrey. The earl was beheaded on the 19th of January; and the duke was ordered for execution on the 29th; but fortunately escaped by the king's death on the 28th. They were condemned without the shadow of a crime; but Henry's political reason for putting them to death, was his apprehension that, if they were suffered to survive him, they would counteract some of his regu-

lations in religion, and might be troublesome to his son. Henry died on the 28th of January 1547, in the 56th year of his age, and was buried at Windsor.

As to his character, it is pretty obvious from the facts above related. Lord Herbert palliates his crimes, and exaggerates what he calls his *virtues*. Bishop Burnet says, "he was rather to be reckoned among the *great* than the *good* princes." He afterwards acknowledges, that "he is to be numbered among the ill princes; but adds, "I cannot rank him with the worst." Sir Walter Raleigh, with infinitely more justice, says, "If all the pictures and patterns of a merciless prince were lost to the world, they might again be painted to the life out of the history of this king." He was indeed a merciless tyrant, a scurvy politician, a foolish bigot, a horrible assassin. See ENGLAND, N^o 253—292.

HENRY of *Huntingdon*, an English historian, of the 12th century, was canon of Lincoln, and afterwards archdeacon of Huntingdon. He wrote, 1. A history of England, which ends with the year 1154. 2. A continuation of that of Bede. 3. Chronological tables of the kings of England. 4. A small treatise on the contempt of the world. 5. Several books of epigrams and love-verses. 6. A poem on herbs; all which are written in Latin.—His invocation of Apollo and the goddess of Tempe, in the exordium of his poem on herbs, may not be unacceptable as a specimen of his poetry.

' Vatum magne parens, herbarum Phœbe repertor,
' Vosque, quibus resonant Tempe jocosæ, Deæ!
' Si mihi sarta prius hederæ florente parâstis,
' Ecce meos flores, serte parata sero.'

HENRY of *Susa*, in Latin *de Sagusio*, a famous civilian and canonist of the 13th century, acquired such reputation by his learning, that he was called *the source and splendour of the law*. He was archbishop of Embrun about the year 1258, and cardinal bishop of Ostia in 1262. He wrote *A summary of the canon and civil law*; and a *commentary on the book of the decretals*, composed by order of Alexander IV.

HENRY the *Minstrel*, commonly called *Blind Harry*, an ancient Scottish author, distinguished by no particular surname, but well known as the composer of an historical poem reciting the achievements of Sir William Wallace. This poem continued for several centuries to be in great repute; but afterwards sunk into neglect, until very lately that it has been again released from its obscurity by a very neat and correct edition published at Perth under the inspection and patronage of the earl of Buchan.

It is difficult to ascertain the precise time in which this poet lived, or when he wrote his history, as the two authors who mention him speak somewhat differently. Dempster, who wrote in the beginning of the 17th century, says that he lived in the year 1361: but Major, who was born in the year 1446, says that he composed this book during the time of his infancy, which we must therefore suppose to have been a few years posterior to 1446; for if it had been composed that very year, the circumstance would probably have been mentioned. As little can we suppose, from Mr Dempster's words, that Henry was born in 1361: for though he says that he *lived* in that year, we must naturally

Henry.

turally imagine rather that he was then come to the years of maturity, or began to distinguish himself in the world, than that he was only born at that time. The author of the dissertation on his life, prefixed to the new edition of the poem, endeavours to reconcile matters in the following manner: "It is not indeed impossible that he might be born in or about that year (1361). In the time of Major's infancy he might be about 83 years of age. In that case, it may be supposed that it was the work of his old age to collect and put in order the detached pieces of his history of Wallace, which he had probably composed in those parts of the country where the incidents were said to have happened."

We are entirely ignorant of the family from which Henry was descended; though, from his writings, we should be led to suppose that he had received a liberal education. In them he discovers some knowledge in divinity, classical history, and astronomy, as well as of the languages. In one place he boasts of his celibacy, which seems to indicate his having engaged himself in some of the religious orders of that age. From what Major says further of him, we may suppose his profession to have been that of a travelling bard; though it does not appear that he was skilled in music, or had no other profession than that just mentioned. His being blind from his birth, indeed, makes this not improbable; though even this circumstance is not inconsistent with the supposition of his being a religious mendicant. "The particulars (says Major) which he heard related by the vulgar, he wrote in the vulgar verse, in which he excelled. By reciting his histories before princes or great men, he gained his food and raiment, of which he was worthy." It is thus probable that he would be a frequent visitor at the Scottish court; and would be made welcome by those great families who could boast of any alliance with the hero himself, or took pleasure in hearing his exploits or those of his companions.

With regard to the authenticity of his histories, Major informs us only that he "does not believe every thing that he finds in such writings;" but from other testimonies it appears, that he consulted the very best authorities which could at that time be had. Though, according to the most early account of Henry, it appears to have been at least 56 years after the death of Wallace that Henry was born; yet he is said to have consulted with several of the descendants of those who had been the companions of that hero while he achieved his most celebrated exploits, and who were still capable of ascertaining the veracity of what he published. The principal of these were Wallace of Craigie and Liddle of that ilk; who, he says, persuaded him to omit in his history a circumstance which he ought to have inserted. Besides these, he consulted with the principal people of the kingdom; and he utterly disclaims the idea of having adhered entirely to any unwritten tradition, or having been promised any reward for what he wrote. His chief authority, according to his own account, was a Latin history of the exploits of Sir William, written partly by Mr John Blair and partly by Mr Thomas Gray, who had been the companions of the hero himself. Henry's account of these two authors, is to the following purpose: "They became acquainted with Wallace when the latter was

only about 16 years of age, and at that time a student at the school of Dundee; and their acquaintance with him continued till his death, which happened in his 29th year. Mr John Blair went from the schools in Scotland to Paris, where he studied some time, and received priests orders. He returned to Scotland in 1296, where he joined Wallace, who was bravely asserting the liberties of his country. Mr Thomas Gray, who was parson of Libberton, joined Wallace at the same time. They were men of great wisdom and integrity, zealous for the freedom of Scotland; and were present with Wallace, and assisting to him, in most of his military enterprises. They were also his spiritual counsellors, and administered to him godly comfort. The history written by these two clergymen was attested by William Sinclair bishop of Dunkeld, who had himself been witness to many of Wallace's actions. The bishop, if he had lived longer, was to have sent their book to Rome, for the purpose of obtaining the sanction of the pope's authority."

The book which Henry thus appeals to as his principal authority is now lost, so that we have no opportunity of comparing it with what he has written. The character given by Dempster of Henry, however, is more favourable than that by Major. He tells us, that "he was blind from his birth; a man of singular happy genius; he was indeed another Homer. He did great honour to his native country, and raised it above what was common to it in his age. He wrote, in the vernacular verse, an elaborate and grand work, in ten books, of the deeds of William Wallace." In this account there is a mistake; for the poem contains eleven or twelve books; but Dempster, who wrote in a foreign country, and had not a printed copy of Henry's work by him when he wrote his eulogium, is excusable in a mistake of this kind.

With regard to his poetical merit, it must undoubtedly rank very far below that of Homer, whom indeed he scarcely resembles in any other respects than that he went about, as Homer is said to have done, reciting the exploits of the heroes of his country, and that he was blind. In this last circumstance, however, he was still worse than Homer; for Henry was born blind, but Homer became blind after he had been advanced in years. Hence Henry, even supposing his genius to have been equal to that of Homer, must have lain under great disadvantages; and these are very evident in his works. The descriptive parts are evidently deficient, and the allusions taken principally from the way in which nature affects those senses of which he was possessed. Thus, speaking of the month of March, he calls it *the month of right digestion*, from the supposed *fermentation* then begun in the earth. Of April he says that the earth is then *able*, or has obtained a power of producing its different vegetables; and of this productive power he appears to have been more sensible than of the effects which commonly strike us most sensibly. "By the working of nature (says he), the fields are again clothed, and the woods acquire their worthy weed of green. May brings along with it great celestial gladness. The heavenly hues appear upon the tender green." In another place he describes the deity of some river, whom he calls *Nymphæus*, "building his bower with *oil and balm*, fulfilled of sweet odour." By reason of these disadvantages, he seldom makes use

Henry.

of similies with which Homer abounds so much ; and few miraculous interpositions are to be found in his poem, though the prophecies of Thomas Lermont commonly called *The Rhymers*, and a prophetic dream of Wallace himself are introduced, as well as the ghost of Fawdon, a traitor who had joined Wallace, and whom the latter in a fit of passion had killed. In other respects, the same inextinguishable thirst of blood which Homer ascribes to his hero Achilles is ascribed to Wallace, though in all probability the mind of Wallace was too much enlightened to admit of such sentiments. A vast degree of courage and personal strength are ascribed to him, by means of which the exploits of the whole army are in effect transferred to a single person. As long as he is invested with the command, the Scots are victorious and irresistible ; when deprived of it, they are enslaved and undone. After struggling for some time against an inveterate and powerful faction, disdaining to feign submission, he is taken by treachery, and died a martyr to the freedom of his country. The poem, on the whole, is valuable, on account of our being able to trace, by its means, the progress which the English language had made at that time in Scotland: the manners of the Scots in that age : as the favourite dress of green which at that time was the taste of the inhabitants of Scotland, &c. With regard to the authenticity of his relations, it is impossible to suppose any other thing than that they are partly true and partly false. The general thread of the story may undoubtedly be looked upon to be genuine, though embellished with poetical fictions and exaggerations ; and his constant appeals to the book already mentioned, though it is now lost, must be looked upon as a strong testimony in his favour : for we cannot suppose that at the time he lived, when we may say that the transactions which he relates were recent, he would have had the confidence to appeal to a book which had not been generally known to have an existence ; and its being now lost can never be any argument against it, when we consider the difficulty there was of preserving books before the invention of printing ; the confusions in which Scotland was frequently involved ; and that the exploits of Wallace, who must be supposed to have been a kind of rival to the great Bruce, could not be so agreeable to the court as those of the more successful hero ; and therefore the history of them might be suffered to fall into oblivion, though written in elegant Latin, while a most ridiculous poem in that language on the battle of Bannockburn has been preserved to this day.

HENRY Prince of Wales, eldest son of King James VI. of Scotland by his queen Anne sister of the king of Denmark, and one of the most accomplished princes of the age in which he lived, was born on the 19th of February, 1594. The birth of the prince was announced by embassies to many foreign powers, with invitations to be present at the ceremony of his baptism, which was thus delayed for a considerable time. Mr P ter Young, who, along with the celebrated George Buchanan, had been preceptor to his majesty, was sent to the courts of Denmark, Brunswic, and Mecklenburg, the duke of Mecklenburg being great-grandfather to the prince by the mother's side ; the laird of East Weems to France and England ; and Sir Robert Keith, and Captain Murray provost of St Andrew's,

to the States General, who at that time were struggling against the Spanish tyranny, and not yet declared a free state. All these ambassadors were cordially received, and others appointed in return except by the courts of France and England. Henry IV. at that time king of France, though the Scots ambassador had formerly been one of his own servants, neither made any present, nor appointed an ambassador. Queen Elizabeth had designed to act in the same manner till she heard of the behaviour of Henry ; after which she honoured James by appointing an ambassador of very high rank, Robert earl of Sussex. This ambassador, however, was so long of making his appearance, that the queen imagined the ceremony would be over before his arrival ; for which reason she sent a message to the earl, commanding him in that case not to enter Scotland nor deliver her present. But James had been more obsequious ; and not only delayed the ceremony till the English ambassador arrived, but distinguished him from the rest by having a canopy carried over his head at the procession, supported by the lairds of Cessford, Buccleugh, Duddope, and Traquair. The ceremony was performed with great magnificence ; after which the ambassadors presented their gifts. That from the United States was the most valuable. It consisted of two gold cups worth 12,400 crowns, with a box of the same metal, weighing in all about 400 ounces, containing besides the grant of a pension of 5000 florins annually to the prince for life. The English ambassador gave a cupboard of plate curiously wrought, and valued at 3000l. sterling ; and the Danish ambassador two gold chains, one for the queen and another for the prince. The baptism was celebrated on the 6th of September 1594, and the child named Frederick-Henry and Henry-Frederick.

The young prince was now committed to the care of the earl of Mar, who was assisted in this important charge by Annabella countess-dowager of Mar, daughter of William Murray of Tullibardine, and paternal ancestor of the present duke of Athol. This lady was remarkable for the severity of her temper, so that the prince met with little indulgence while under her tuition ; notwithstanding which, he showed great affection for his governess all the time she had the care of him. Next year, however (1595), the queen engaged the chancellor, Lord Thirlestane, in a scheme to get the prince into her own power : but the king having found means to dissuade her majesty from the attempt, showed afterwards such marks of displeasure to the chancellor, that the latter fell into a languishing disorder and died of grief.

In his sixth year Prince Henry was committed to the care of Mr Adam Newton a Scotsman, eminently skilled in most branches of literature, but particularly distinguished for his knowledge of the Latin language. Under his tutorage the prince soon made great progress in that language, as well as in other branches of knowledge ; insomuch that before he had completed his sixth year, his father wrote for his use the treatise entitled *Basilican Doron*, thought to be the best of all his works.

In his seventh year, Prince Henry began his correspondence with foreign powers. His first letter was to the States of Holland ; in which he expressed his regard and gratitude for the good opinion they had conceived of him, and of which he had been informed

Henry. by several persons who had visited that country; concluding with a request that they would make use of his interest with his father in whatever he could serve them, promising also his service in every other respect in which he could be useful, until he should be able to give farther instances of his good-will and affection.

At this early period the prince began to add to his literary accomplishments some of the more martial kind, such as riding, the exercise of the bow, pike, &c. as well as the use of fire-arms; and indeed such was the attachment he showed throughout his whole lifetime to military exercises, that had he attained the years of maturity, there can scarce be a doubt that he would have distinguished himself in a most eminent manner. In all his exercises he made surprising progress; and not only in those of the military kind, but in singing, dancing, &c. On his ninth birth-day he sent a letter in Latin to the king, informing him that he had read over Terence's *Hecyra*, the third book of Phædrus's Fables, and two books of Cicero's Epistles; and that now he thought himself capable of performing something in the commendatory kind of epistles. His accomplishments were soon spoken of in foreign countries; and these, along with the general suspicion that James favoured the Catholic party, probably induced Pope Clement VIII. to make an attempt to get him into his hands. With this view he proposed, that if James would entrust him with the education of the young prince, he would advance such sums of money as would effectually establish him on the throne of England. This happened a little before the death of Elizabeth; but James, notwithstanding his ambition to possess the crown of England, of which he was not yet altogether certain, withstood the temptation. He alleged, that it would be unnatural for him, as a father, to allow his son to be brought up in the belief of a doctrine which he himself did not believe: and even though he should act in his private capacity in such an unnatural manner, he could not answer for it to the nation, he being heir-apparent to the crown, and the kingdom at large much interested in whatever concerned him. On the death of the queen of England, James was obliged to leave Scotland in such haste, that he had not time to take a personal leave of his son, and therefore did so by letter, which was answered by the prince in Latin. The queen, however, who had been desired to follow the king to London in three weeks, but to leave the prince in Scotland, thought proper to make another attempt to get her son into her own power. With this view she took a journey to Stirling, where the prince resided, but was opposed in her designs by the friends of the house of Mar; and this affected her so much, that she miscarried of a child of which she was then pregnant. The king, hearing of this misfortune, ordered the prince to be delivered to his mother; but refused to inflict any punishment on the earl of Mar, which the queen insisted upon, that nobleman having been with the king at London, and entirely innocent of the whole affair. Instead of punishing him, therefore, he caused him to be acquitted by an act of the public council at Stirling; invested him with the order of the Garter; made him a grant of several abbey and other church lands; and raised him to the post of lord high treasurer after the disgrace of the earl of Somerset; in which employment he continued till he could

no longer perform the duties of his office through age and infirmity. Henry.

In the month of July this year (1603) Prince Henry was invested with the order of the Garter; after which he was presented to the queen in his robes, and greatly commended by all who saw him on account of his majestic carriage and religious behaviour at the altar, as well as the quickness of his understanding and ready answers. Being obliged to leave London on account of the plague, he retired to Otelands, a royal palace near Weybridge in Surrey, where a separate household was appointed for him and his sister Elizabeth. The appointment consisted at first of 70 servants, of whom 22 were to be above stairs and 48 below. In some weeks the number was augmented to 104, of whom 51 were above stairs and 53 below; but before the end of the year they were augmented to 141, of whom 56 were above stairs and 85 below. From Otelands he removed the same year to Nonsuch in Surrey, and from thence to Hampton Court, where he resided till Michaelmas 1604; after which he returned to his house at Otelands, his servants having all this time been kept on board-wages.

In the tenth year of his age, Henry began to show a wonderful desire of becoming master of all those accomplishments which are necessary to constitute a great prince. Without desisting from his attention to polite literature, he applied himself in the most assiduous manner to the knowledge of naval and military affairs. To give him the first rudiments of the former, a small vessel was constructed 28 feet long and 12 broad, curiously painted and carved; on board of which he embarked with several of the principal nobility, and sailed down as far as Paul's Wharf, where with the usual ceremonies, he baptized it by the name of the *Disdain*. Mr Pett, the builder of this ship, was recommended to the prince by the high admiral in such strong terms, that his highness took him immediately into his service, and continued his favour to him as long as he lived.

Prince Henry now began to show himself equally a patron of military men and of learning. His martial disposition induced him to take notice of Colonel Edmondes, a brave Scots officer in the Dutch service, who had raised himself solely by his merit. To him he applied for a suit of armour to be sent over from Holland: but though the colonel executed his commission, he reaped no benefit from his highness's favour, dying in a short time after the armour was purchased, before he had any opportunity of sending it over. In matters of literature the prince appears to have been a very good judge. He patronized divines, and appears to have been naturally of a religious turn of mind. His attachment to the Protestant religion appears to have been excessive; as it never was in the power of the queen, who favoured the Catholic party, to make the least impression upon him. Her machinations for this purpose were discovered by the French ambassador; who, in a letter dated June 7. 1604, informed his master of them, and that the Spaniards were in hopes of being able by her means to alter the religion in England, as well as to prejudice the prince against France, which the queen said she hoped that her son would one day be able to conquer like another Henry V. By another letter, of date 22d October the

Henry. same year, the ambassador, after taking notice of the queen's immoderate ambition, adds, that she used all her efforts to corrupt the mind of the prince, by flattering his passions, diverting him from his studies, and representing to him, out of contempt to his father, that learning was inconsistent with the character of a great general and conqueror; proposing at the same time a marriage with the infanta of Spain. Notwithstanding these remonstrances, however, the prince continued to behave as usual, and to patronise the learned no less than before. He presented John Johnston, one of the king's professors at St Andrew's with a diamond, for having dedicated to him an Historical Description of the kings of Scotland from the foundation of the monarchy to that time; after which the professor added a *carmen encomiasticum*, which was transmitted to his highness in November 1605. Many other authors also sought and obtained his countenance. In 1606 Mr John Bond ushered his edition of Horace into the world with a polite dedication to the prince, whom he highly compliments on account of the progress he had made in learning. In 1609 a book was sent over to him from France by Sir George Carew, the British ambassador there, tending to disprove the doctrine of the Catholics concerning the church of Rome being the first of the Christian churches. The same year the learned Thomas Lydyat published his *Emendatio Temporum*, which appeared under the patronage of the prince; and with this performance his highness was so well pleased, that he took the author into his family to read to him, and made him his chronographer and cosmographer. Paul Buys or Busius also sent him a letter with a dedication of the second part of his *Fanctectis*; in which he bestows upon him the highest compliments on the great expectations which were formed of him, and of the hopes entertained by the reformed Christian churches that he would prove a powerful support to their cause, and antagonist to the errors of Rome. In 1611 Dr Tooker, in his dedication of an Answer to Becanus a Jesuit, who had written against a piece done by his majesty himself, styles his highness "the Mæcenas of all the learned." Another treatise against the same Becanus was also printed this year, and dedicated to the prince.

Many other authors, whom our limits will not allow us to take notice of, were fond of dedicating their performances to his highness; nor was his correspondence less extensive than his erudition. We have already taken notice of his having written his first public letter to the states of Holland. He was congratulated by the elector palatine, afterwards married to the princess Elizabeth, on the discovery of the gunpowder-plot. On the same occasion also Lord Spenser wrote him a letter, accompanying it with the present of a sword and target; "instruments (says he) fit to be about you in those treacherous times; from the which, I trust, God will ever protect your most royal father, &c." Previous to this he had corresponded in Latin with the doge of Venice, the landgrave of Hesse, and the king of Denmark; in French with the duke of Savoy, and in Latin with the duke of Brunswic and Uladislaus king of Poland; besides a number of other eminent persons too tedious to enumerate.

The great accomplishments of Henry soon caused him to be taken notice of by the most eminent princes

Henry. in Europe. In 1606 Henry IV. of France ordered his ambassador to pay him special regard on all occasions. He desired him likewise to salute the prince in the name of the dauphin, afterwards Lewis XIII. and to inform him of the regard the latter had for him. A message was also sent by the same ambassador to M. de St Anthoine, appointed to be riding-master to his highness, enjoining him to do his duty in that office: and assuring him that his majesty would be as much pleased with it as if the service had been done to himself. To these messages the prince returned very proper answers; and afterwards performed his exercise in the riding-school before the ambassador himself, that the latter might send an account thereof to his master. On this occasion he mounted two horses, and acquitted himself so well that the ambassador in a letter to M. de Villeroy, the French secretary, gave him the character of "a prince who promised very much, and whose friendship could not but be one day of advantage." Having then set forth the propriety of cultivating a good understanding with him, he tells the secretary, that the dauphin might make a return for some dogs which the prince had sent him, by a suit of armour well gilt and enamelled, together with pistols and a sword of the same kind; also two horses, one of them a barb.— This year also the prince waited on his uncle the king of Denmark, who had come to England on a visit to King James; and this monarch was so much pleased with his company, that he presented him at parting with his vice-admiral and best fighting ship, valued at no less than 2500l. also with a rapier and hanger, valued at 2000 marks. The states of Holland were equally ready to show their attachment. On the 25th of August this year they sent a letter to the prince in French, accompanied with the present of a set of table-linen, which they thought, as being the produce of their own country, would be agreeable to him; and they requested his love and favour towards their state: in return for which they promised to be always ready to show their regard for him, and to do him all possible service; as the ambassador himself was ordered more particularly to declare. About this time the prince himself wrote a letter to Henry IV. acknowledging the kindness which his majesty had shown him for several years, and confirmed of late by the latter offering him under his own royal hand his friendship and that of the dauphin.

While James was this year employed in hunting, the French ambassador, who had been obliged to quit London on account of the plague, took frequent opportunities of waiting upon his highness, as did also the Spanish ambassador, whose ostensible reason was to inform him about some horses which were to be sent him from Spain. The prince's partiality towards France, however, was so evident, that the French ambassador, in a letter dated 31st October 1606, mentions, that "as far as he could discover, his highness's inclination was entirely towards France, and that it would be wrong to neglect a prince who promised such great things. None of his pleasures (continued he) savour the least of a child. He is a particular lover of horses and whatever belongs to them: but is not fond of hunting; and when he goes to it, it is rather for the pleasure of galloping than that which the dogs give him. He plays willingly enough at tennis, and another Scottish

diversion very like mall; but this always with persons elder than himself, as if he despised those of his own age. He studies two hours a-day, and employs the rest of his time in tossing the pike, or leaping, or shooting with the bow, or throwing the bar, or vaulting, or some other exercise of the kind, and he is never idle. He shows himself likewise very good-natured to his dependents, supports their interests against any persons whatever, and pushes whatever he undertakes for them or others with such zeal as gives success to it. For besides his exerting his whole strength to compass what he desires, he is already feared by those who have the management of affairs, and especially by the earl of Salisbury, who appears to be greatly apprehensive of the prince's ascendant; as the prince, on the other hand, shows little esteem for his lordship." In this letter the ambassador further goes on to remark, that some of the prince's attendants had formerly been made to expect pensions from France; and he was of opinion that they ought to be gratified on account of the interest they had with the prince. He adds, that the queen had less affection for Prince Henry than for his brother the duke of York, afterwards Charles I.; which the prince seemed to have discovered, and sometimes used expressions to that purpose: that the king also seemed to be jealous of his son's accomplishments, and to be displeased with the quick progress he made.

In 1607 the prince received the arms and armour which Henry IV. sent him as a present; and these being accompanied with a letter, the prince returned an answer by a Mr Douglas, who was introduced to the king of France by the ambassador Sir George Carew. His majesty, contrary to custom, opened the prince's letter immediately; and was so much surprised at the beauty of the character, that he could not be satisfied that it was the prince's hand until he compared the signature with the rest of the writing. In his letter to the British court on this occasion; the ambassador sets forth in strong terms the affection expressed by the French monarch for the prince; "accounting of him as of his own son, as he hoped that his good brother of Great Britain would do the like of the Dauphin." The French ambassador also gave a character of his highness similar to that already mentioned; remarking, "that the prince had great accomplishments and courage; would soon make himself talked of, and possibly give jealousy to his father, and apprehensions to those who had the greatest ascendant at court." With regard to the pensions to his attendants, he was at first of opinion that they ought to be granted; but afterwards altered his mind, perceiving that there was little probability of the prince being influenced by any of his attendants, as he was much more inclined to be guided by his own judgment than by the suggestions of others.—In the month of July this year the Dutch ambassadors came recommended to Prince Henry by the States, who wrote to him that they had ordered their ambassadors to kiss his highness's hands on their part, and desired him to continue his friendship to their republic, and to allow their ambassadors a favourable audience, and the same credit as to themselves.

All this attention paid him by foreign powers, all his attention to his own improvements in learning and the military art, and all the temptations which we

cannot but suppose a youth in his exalted station to have been exposed to, seem never to have shaken the mind of this magnanimous prince in the least, or to have at any time made him deviate from the strict line of propriety. We have already mentioned his attachment to the Protestant religion; and this appears not to have been grounded upon any prejudice or opinion inculcated upon his infant mind by those who had the care of him, but from a thorough conviction of the truth of the principles which he professed. On the discovery of the gunpowder-plot, he was so impressed with gratitude towards the Supreme Being, that he never afterwards omitted being present at the sermon preached on the occasion. In his 14th year the prince showed himself capable of distinguishing the merit of religious discourses, and paid particular regard to such divines as were most remarkable for their learning and abilities. Among others, he honoured with his attention the learned and eloquent Mr Joseph Hall, then rector of Halstead in Suffolk, afterwards dean of Worcester, and successively bishop of Exeter and Norwich. His highness was so much pleased with a book of Meditations published by that divine, that he pressed him to preach before him; and having heard two of his sermons, he engaged him as one of his chaplains; inviting him afterwards to stay constantly at his court, while the other chaplains waited only in their turns; promising, moreover to obtain from the king such preferments as should fully satisfy him. Mr Hall, however, from a reluctance to leave his new patron Lord Denny, afterwards earl of Norwich, did not accept of these honourable and advantageous proposals.

In his family the prince took the utmost care to preserve decency and regularity. He ordered boxes to be kept at his three houses of St James's, Richmond, and Nonsuch, for the money required of those who were heard to swear; the fines levied on such offenders being given to the poor. He had, indeed, a particular aversion to the vice of swearing and profanation of the name of God. When at play, he never was heard to do so; and on being asked why he did not swear as play as well as others; he answered, that he knew no game worthy of an oath. The same answer he is said to have given at a hunting-match. The stag, almost quite spent, crossed a road where a butcher was passing with his dog. The stag was instantly killed by the dog; at which the huntsmen were greatly offended, and endeavoured to irritate the prince against the butcher: but his highness answered coolly, "What if the butcher's dog killed the stag, what could the butcher help it?" They replied, that if his father had been so served, he would have sworn so that no man could have endured. "Away," cried the prince, "all the pleasure in the world is not worth an oath."

The regard which Prince Henry had for religion was manifest from his attachment to those who behaved themselves in a religious and virtuous manner. Among these was Sir John Harrington, whose father had been knighted by Queen Elizabeth, and created by King James a baron of England in 1603 by the title of Lord Harrington of Exton in Rutland. He was entrusted with the care of the Princess Elizabeth after her marriage with the elector palatine, whom he attended to Heidelberg in 1613, and died at Worms on the 24th of August following. His son, who in the

Henry. year 1604 had been created knight of the Bath, was, as soon as he came to the years of discretion, remarkable for his piety; insomuch that he is said to have kept an exact diary of his life, and to have examined himself every week as to the progress he had made in piety and virtue, and what faults he had committed during that time. He was affable and courteous to all, and remarkable for his humanity to those in distress; all which good qualities so endeared him to the prince, that he entered into as strict a friendship with him as the disproportion between their stations would allow. There are still several letters extant which passed between them, chiefly upon classical subjects. This worthy and accomplished nobleman died in February 1614.

In his friendship Prince Henry appears to have been very sincere, and inviolably attached to those whom he once patronised. He had a great regard for the unfortunate Lady Arabella Stewart, sister of Henry Lord Darnley, the king's father; and there is still extant a letter from this lady to the prince in return for some kindness he had bestowed on a kinsman of hers at her recommendation. He expressed much compassion for her misfortunes; she having excited the king's jealousy on account of her marriage with Mr William Seymour, afterwards earl and marquis of Hertford, and restored in 1660 to the dukedom of Somerset. But on her attempting to escape from the house in Highgate where she was confined, and to go abroad with her husband, his highness expressed some resentment against her; though in all probability his apprehensions, as well as those of the king, were ill-founded.

As early as the year 1605, the prince, though then only in his 11th year, manifested his gratitude and attachment to those who had served him, in the instance of his tutor Mr Newton already mentioned. That gentleman had been promised by his majesty the deanery of Durham upon the demise of the archbishop of York. On this promise Mr Newton had relief for two years; and as soon as the prelate died, his highness took care to put the king in mind of his promise; in consequence of which, Mr Newton was installed in his office on the 27th of September 1606.

Mr Pett, the gentleman who first instructed the prince in naval affairs, having been involved with many others in an enquiry concerning their conduct in their respective employments in the royal navy, the prince showed a laudable desire of protecting their innocence. The inquiry was set on foot by the earl of Northampton, lord privy seal and warden of the cinque ports, who had received a commission from the king for the purpose. It was carried on by his agents, however, with such violence and malice, as not only occasioned great trouble and expence to the parties concerned, but almost ruined the navy, besides augmenting his majesty's expences much more than formerly. Mr Pett's trial began on the 28th of April 1609; at which time the reports being very favourable to him, the king determined to examine into the state of the matter himself. For this purpose he went to Woolwich on the 8th of May, attended by the prince; and appointed Sir Thomas Chaloner, his highness's governor, and Sir Henry Briggs then professor of geometry in Gresham college, to decide the controversy which was

then agitated about the proportion of the ships. The measurers declared in favour of Mr Pett; on which the prince exclaimed, "Where be now those perjured fellows, that dare thus to abuse his majesty with false informations? Do they not worthily deserve hanging?" During the whole time he stood near Mr Pett to encourage him; and when the king declared himself satisfied of his innocence, the prince took him up from his knees, expressing his own joy for the satisfaction which his father had received that day; protesting that he would not only countenance Mr Pett for the future, but provide for him and his family as long as he lived.

The courage, intrepid disposition, and martial turn of this prince, were manifest from his infancy. It is related of Alexander the Great, that at a very early period of his life he showed more skill than all his father's grooms in the breaking of his favourite horse Bucephalus. An anecdote somewhat similar is recorded of Prince Henry. He was hardly ten years of age, when he mounted a very high-spirited horse, in spite of the remonstrances of his attendants; spurred the animal to a full gallop; and having thoroughly wearied him, brought him back at a gentle pace, asking his servants at his return, "How long shall I continue in your opinion to be a child?" From the very first time that he embarked on board the small vessel formerly mentioned, he continued to pay the utmost attention to naval affairs. In August 1607, he visited the royal navy at Woolwich, where he was received by Mr Pett, and conducted aboard the Royal Anne, where he had 31 large pieces of ordnance ready to be fired. This was done unexpectedly as soon as the prince reached the poop; at which he expressed great satisfaction. After visiting the dock-yard, and surveying what was done of a ship then building for himself, he went ashore, and having partaken of an entertainment prepared for him by Mr Pett, he was by him conducted to the mount, where the ordnance were again charged and ready to be placed for firing. The prince insisted upon an immediate discharge, but suffered himself to be persuaded against it by Mr Pett's representation of the danger of firing so many ordnance loaded with shot while his highness stood close by: on a signal given by him, however, by holding up his handkerchief, after he had removed to a proper distance with his barge, the ordnance were discharged as he had desired. In his 16th year he paid several visits to Woolwich, in order to see the above-mentioned ship which was building for himself. When finished, it was the largest that had ever been seen in England: the keel being 114 feet in length, and the cross-beam 44 feet; carrying 64 pieces of great ordnance; the burden about 1400 tons; and the whole curiously ornamented with carving and gilding. His highness having received this ship in a present from his majesty, went to see it launched on the 24th of September 1609. The narrowness of the dock, however, having prevented its being done at that time, the prince, who staid behind the rest of the company in order to prepare for the ceremony next morning, returned by three o'clock through a storm of rain, thunder, and lightning; and standing on the poop while the ship was launched, gave it the name of the *Prince Royal*.

In 1611 his highness made a private visit to Chatham,

tham, where he first went on board the *Prince Royal*, and afterwards from ship to ship; informing himself particularly of every thing of moment relating to the state of all the different ships, and even pinnaces lying there at that time. Next day he went by water up to Stroud; where, contrary to all the remonstrances of his attendants, he caused the ordnance to be shot over his barge. From Stroud he went to Gravesend, where the magistrates received him with a discharge of all their small arms and the ordnance of the block-houses.

About the middle of January 1612, Prince Henry ordered all his majesty's master-shipwrights and builders to attend him, to consider of a proposition concerning the building of ships in Ireland made by a Mr Burrel. Some of his propositions were, that he should build any ship from 100 to 600 tons, with two decks and a half, at the rate of five pounds per ton; that he would build any ship from 600 to 1000 tons, with three whole decks, at the rate of seven pounds per ton; that he should build a ship of 600 tons within a certain time, &c. Mr Pett was employed to see that this contract was fulfilled on the part of Mr Burrel. Among the prince's papers, a list of the royal navy was found after his death, with an account of all the expences of fitting out, manning, &c. which must now be accounted a valuable addition to the naval history of those times. His passion for naval affairs naturally led him to a desire of making geographical discoveries; of which, however, only two instances have reached our times. One was in 1607, when he received from Mr Tindal his gunner, who had been employed by the Virginia company, a draught of James's river in that country, with a letter dated 22d June the same year. In this letter Mr Tindal remarks, that his fellow-adventurers had discovered that river; and that no Christian had ever been there before; that they were safely arrived and settled; that they found the country very fruitful; and that they had taken a real and public possession in the name and to the use of the king his highness's father. The other instance was in the year 1612, the same in which he died, when he employed Mr Thomas Button, an eminent mariner, to go in quest of a north-west passage. Mr Button accordingly set sail with two ships, named the *Resolution* and *Discovery*; the same designations with those in which the late Captain Cook made his last voyage. Both of them were victualled for 18 months: but wintering in these northern regions, they did not return till after the prince's decease, so that Captain Button was never sent on another voyage: nevertheless, he returned fully convinced of the existence of such a passage; and even told the celebrated professor Briggs of Gresham college, that he had convinced the king of his opinion.

The martial disposition of the prince, which was conspicuous on all occasions, eminently displayed itself on the occasion of his being invested in the principality of Wales and duchy of Cornwall, which took place in the year 1610. Previous to this ceremony, he, under the name and character of *Mæliades*, lord of the isles, caused a challenge to be given, in the romantic style of those times, to all the knights in Great Britain. The challenge, according to custom, was accepted; and on the appointed day, the prince, as-

sisted only by the duke of Lenox, the earls of Arundel and Southampton, Lord Hay, Sir Thomas Somerset, and Sir Richard Preston, who instructed his highness in arms, maintained the combat against 56 earls, barons, knights, and esquires. Prince Henry himself gave and received 32 pushes of the pike, and about 360 strokes of swords; performing his part very gracefully, and to the admiration of all who saw him, he being not yet 16 years of age. Prizes were bestowed upon the earl of Montgomery, Mr Thomas Darry, and Sir Robert Gordon, for their behaviour at this combat. The ceremony of installation was performed on the 4th of June 1610, at which time every kind of magnificence that could be devised was displayed. Among other pageants used on this occasion was that of Neptune riding on a dolphin and making speeches to the prince; also of a sea-goddess upon a whale. After the ceremony the prince took his place on the left hand of his majesty; sitting there in his royal robes, with the crown on his head, the rod in one hand, and in the other the patent creating him prince of Wales and duke of Cornwall. A public act was then read, testifying that he had been declared prince of Great Britain and Wales. He was afterwards served at table with a magnificence not unworthy of royalty itself; the whole concluding with a grand masquerade and tournament.

In one instance, the extreme desire which Prince Henry had of being instructed in military affairs, carried him beyond those bounds which European nations have prescribed to one another. In 1607 the prince de Joinville, brother to the duke of Guise, came to England, having been obliged to leave France in consequence of his having made love to the countess de Moret the king's mistress. After having been for a few weeks magnificently entertained at court, he departed for France in the beginning of June. The prince took an opportunity of sending to Calais in the train of the prince an engineer in his own service, who took the opportunity of examining all the fortifications of the town, particularly those of the Rix-Banc. This was discovered by the French ambassador, who immediately gave notice of it to court, but excused the prince, as supposing that what he had done was more out of curiosity than any thing else; and the court seemed to be of the same opinion, as no notice was ever taken of the affair, nor was the friendship between King Henry and the prince in the smallest degree interrupted. The martial disposition of his highness was greatly encouraged by some people in the military line, who put into his hands a paper entitled "Propositions for War and Peace." Notwithstanding this title, however, the aim of the author was evidently to promote war rather than peace; and for this the following arguments were used. 1. Necessity; for the preservation of our own peace, the venting of factious spirits, and instructing the people in arms. 2. The benefits to be derived from the spoils of the enemy, an augmentation of revenue from the conquered countries, &c. This was answered by Sir Robert Cotton in the following manner. 1. That our wisest princes had always been inclined to peace. 2. That foreign expeditions were the causes of invasions from abroad, and rebellions at home, endless taxations, vassalage, and danger to the state from the extent of territory, &c. It

Henry. does not appear, however, that the prince was at all moved by these pacific arguments: on the contrary, his favourite diversions were tilting, charging on horseback with pistols, &c. He delighted in conversing with people of skill and experience in war concerning every part of their profession; caused new pieces of ordnance to be made, with which he learned to shoot at a mark; and was so careful to furnish himself with a breed of good horses, that no prince in Europe could boast of a superiority in this respect. He was solicited by Sir Edward Conway to direct his attention to the affairs of the continent, where Sigismund III. of Poland threatened, in conjunction with the king of Denmark, to attack Gustavus Adolphus, the young king of Sweden; but the death of the prince, which happened this year, prevented all interference of this kind.

To his other virtues, Prince Henry added those of frugality without avarice, and generosity without extravagance. As early as the year 1605 he began to show an attention to his interest as duke of Cornwall, and to take proper measures for securing his revenues there. In 1610 he settled and appointed the officers of his household, making his choice with the greatest prudence, and giving orders for the management and regulation of his affairs with all the wisdom and gravity of an old counsellor. Some lands were now allotted to him for his revenues; and instead of diminishing his income during the short time he was in possession of them, they were found at his death to be some thousands of pounds better than when he obtained them. At this time he showed much reluctance to gratify any of his servants except by promises, as not thinking himself yet authorized to give any thing away; but a short time before his death, he conferred pensions on some of them; and there is no reason to doubt, that had his life been prolonged he would have rewarded them all according to their merit.

Though Prince Henry never interfered much in public business, yet in any little transactions he had of this kind, he always displayed great firmness and resolution, as well as absolute propriety of conduct. In a letter from Sir Alexander Seton, earl of Dunfermling, he is commended for the firmness and resolution with which he repelled the calumnies of some who "had rashly, and with the highest intemperance of tongue, endeavoured to wound the Scottish nation." By this he alluded to some very gross and scurrilous invectives thrown out against the whole body of the Scots by Sir Christopher Pigot, in a debate in the house of commons on an union between the two kingdoms. This gentleman declared his astonishment at the proposal of uniting a good and fertile country to one poor, barren, and in a manner disgraced by nature; and for associating rich, frank, and honest men, with such as were beggars, proud, and generally traitors and rebels to their kings; with many other shameful expressions of the same kind. His majesty was highly offended with the whole council; and Sir Christopher, after being obliged in parliament to retract his words, was expelled the house and imprisoned; in consequence of which, the king was addressed by the states of Scotland, who thanked him for the zeal he had manifested for the honour of their country. In another instance, where the prince wished Mr Fullerton, a Scotsman, to supersede Sir Robert Car, one of the attendants of his

brother the duke of York, contrary to the inclination of the king and earl of Salisbury, his highness carried his point, by persuading Sir Robert of himself to give up the place in question.

Under this year, 1611, the elegant Latin historian of Great Britain from 1572 to 1628, Robert Johnston, places a story, which, though unsupported by any authority but his own, and improbable in itself, must not be omitted here. The prince, according to this writer, requested the king that he might be appointed to preside in the council. This demand was seconded by the king's favourite, Car Viscount Rochester, who urged his majesty to lay his son's request before the council. But the earl of Salisbury, jealous of the growing power of Rochester, and a thorough master of artifice and dissimulation, used all his efforts to defeat whatever measures were proposed by his rival; and being asked soon after his opinion upon this point, whether it was for the public interest that the prince should preside in the council, answered, that he thought it dangerous to divide the government, and to invest the son with the authority of the father. Many others of the privy council having delivered their opinions on the same question, that of the earl of Salisbury was adopted by the majority. But his lordship soon took an opportunity, in a secret conference with the prince, to lament his own situation, and to persuade his highness that Lord Rochester had the only influence in the palace, and privately counteracted all his designs. The prince, on his part, resented the denial of his request, and his exclusion from public business. It was not long before Lord Rochester discovered the earl of Salisbury's practice against him with the prince; to whom he therefore went to clear himself; but his highness turned from him with great indignation, and would not hear his justification. The queen likewise, highly displeased with the viscount, refused to see him, and sought all means of lessening his power. This forwardness imputed to the prince by the historian, in endeavouring to intrude himself into the management of public affairs, is not (as Dr Birch remarks) at all suitable to the character of his highness, or to any other accounts which we have of him; nor ought it to be believed upon the credit of a writer who cites no authority for it, nor indeed for scarce any other assertions in his history, how extraordinary so ever they appear to be, and who frequently ventures to enlarge upon subjects which it was impossible for him to have known. However, it is not much to be doubted, that the prince had no great esteem for Lord Rochester, whose rise to the power of a favourite and a minister he so much disliked, if we may believe a satirical writer of Memoirs*, that he was reported either to have struck his lordship on the back with a racket, or very hardly forborne it. And another historian, not much less satirical, Arthur Wilson†, mentions the bickerings betwixt the prince and the viscount; and that Sir James Elphinston one day observing his highness to be discontented with the viscount, offered to kill him; for which the prince reproved him, and said that if there were cause he would do it himself. But to wave such very suspicious authorities, it will be sufficient, in order to judge of his highness's opinion of the viscount, and his administration at the very height of it, to hear what himself says in a letter to Sir Thomas Edmondson

Henry.

* Francis Osborne's Traditional Memoirs on King James, James Elphinston one day observing his highness to be discontented with the viscount, offered to kill him; for which the prince reproved him, and said that if there were cause he would do it himself. But to wave such very suspicious authorities, it will be sufficient, in order to judge of his highness's opinion of the viscount, and his administration at the very height of it, to hear what himself says in a letter to Sir Thomas Edmondson

Henry. of the 10th of September 1612; "As matters go now here, I will deal in no businesses of importance for some respects."

It is not to be supposed but that the marriage of a prince so accomplished and so much admired would engage the attention of the public. This was indeed the case. The queen, who favoured the interest of Spain, proposed a match with the infanta, and the king of Spain himself seemed to be inclined to the match. In 1611 a proposal was made for a double marriage betwixt the prince of Wales and the eldest daughter of the house of Savoy, and between the prince of Savoy and the lady Elizabeth; but these overtures were very coolly received, being generally disagreeable to the nation. Sir Walter Raleigh, at that time prisoner in the Tower, wrote two excellent treatises against these matches; in one of which he styles the prince *The most excellent and hopeful*, as he does also in the introduction to his Observations on the royal navy and sea-service. About the year 1612, his marriage became an object of general attention. In this affair the king seems to have inclined to match his son with the princess who promised to bring the largest dowry; the nation at large to have been influenced by motives of religion; and the prince himself to have remained entirely passive, and to have been willing to bestow his person with the most perfect indifference on whatsoever princess should be chosen for him. This appears from a letter to the king dated 5th October 1612, in which he considers the match with the second princess of France as in a manner concluded. Proposals had indeed been made of sending her over to England for her education, she being only nine years of age at that time; but Villeroy the French minister was of opinion, that this ought to be delayed for a year longer. The reasons assigned by the prince for wishing her coming to England at that time were merely political: 1. Because the French court, by having the princess in their power, might alter her mind as they pleased: 2. That there would thus be a greater likelihood of converting her to the Protestant religion; and 3. That his majesty's credit would be better preserved when both daughters (the eldest being promised to the prince of Spain) should be delivered at the same time, though the conclusion of the one marriage might be much later than of the other. With regard to the exercise of her religion, the prince expressed himself rather in severe terms, wishing his majesty only to allow her to use it in "her most private and secret chamber." He then argues with the most philosophic indifference of the propriety of a match with the French princess rather than with one of the house of Savoy: concluding at last in the following words; "If I have incurred in the same error that I did last by the indifference of my opinion, I humbly crave pardon of your majesty, holding it fitter for your majesty to resolve what course is most convenient to be taken by the rules of the state, than for me who am so little acquainted with subjects of that nature: and besides, your majesty may think, that my part to play, which is to be in love with any of them, is not yet at hand." On the whole, it appeared, that there never was any real design in the king or prince to bring this matter to a conclusion; and that the proposal had been made only with a view to break off the match of the eldest

daughter with the prince of Spain, which could not now be done.

Prince Henry, notwithstanding his indifference in matrimonial matters, applied himself with the utmost assiduity to his former employments and exercises, the continual fatigue of which was thought to impair his health. In the 19th year of his age his constitution seemed to undergo a remarkable change: he began to appear pale and thin, and to be more retired and serious than usual. He complained now and then of a giddiness and heavy pain in his forehead, which obliged him to stroke up his brow before he put on his hat: he frequently bled at the nose, which gave great relief, though the discharge stopped some time before his death. These forebodings of a dangerous malady were totally neglected both by himself and his attendants, even after he began to be seized at intervals with fainting fits. Notwithstanding these alarming symptoms, he continued his usual employments. On the arrival of Count de Nassau in England, he waited upon him as though nothing had been the matter; and when the subject of the princess Elizabeth's marriage came to be canvassed, he interested himself deeply in the affair, and never desisted till the match with the elector palatine was concluded. In the beginning of June 1612, the prince went to Richmond, where he continued till the progress: and notwithstanding the complaints above mentioned, he now took the opportunity of the neighbourhood of the Thames to learn to swim. This practice in an evening, and after supper, was discommended by several of his attendants; and was supposed to have stopped the bleeding at the nose, from which he had experienced such salutary effects. He could not, however, be prevailed upon to discontinue the practice; and took likewise great pleasure in walking by the river side in moon-light to hear the sound and echo of the trumpets, by which he was undoubtedly too much exposed to the evening dews. Through impatience to meet the king his father, he rode 60 miles in one day; and having rested himself during the night, he rode the next day 36 miles to Belvoir Castle, where he met the king at the time appointed. During the heat of the season also he made several other fatiguing journeys, which must undoubtedly have contributed to impair his health. At the conclusion of the progress, he gave a grand entertainment to the court from Wednesday till Sunday evening, when the king and queen with the principal nobility attended at supper. Next day he hastened to his house at Richmond, where he expected the elector palatine, and began to give orders for his reception, also to take measures for rewarding his servants. To some of these he gave pensions, and promised to gratify the rest as soon as possible. From this time, however, his health daily declined. His countenance became more pale, and his body more emaciated: he complained now and then of drowsiness; which frequently made him ask his attendants concerning the nature and cure of an epidemic fever, probably of the putrid kind, which at that time prevailed in England, and was supposed to have been brought thither from Hungary. He now began frequently to sigh, as is usual for persons afflicted with disorders of that kind. The malady increased in the beginning of October, though he used his utmost endeavours to

Henry. conceal it, and occupied himself as usual; only that now, instead of rising early in the morning as before, he would commonly keep his bed till nine. On the 10th of that month he had two slight fits of an ague, which obliged him to keep his chamber; and on the 13th his distemper seemed to be augmented by a violent diarrhoea, which, however, gave so much relief next day, that he insisted upon being removed from Richmond to St James's, in order to receive the elector palatine. On his arrival there, some of his attendants began to be alarmed by the signs of sickness which appeared upon him, though he himself made no complaint, and even allowed his physician to go to his own house. The elector arrived on the 16th, and the prince waited upon him at Whitehall; but his disease had now gained so much ground, that his temper underwent a very considerable alteration, and he became peevish and discontented with almost every thing: nevertheless he still continued to give orders about what related to the ceremony of his sister's marriage; and kept company as much as he could with the elector and the count de Nassau, with whose conversation he seemed to be particularly delighted. So great was his activity even at this time, that he played a match at tennis on the 24th of October. At this time he exposed himself in his shirt, seemingly without any inconvenience; but at night he complained of a greater degree of lassitude than usual, and of a pain in his head. Next day, being Sunday, he attended divine service, and heard two sermons; after which he dined with his majesty, seemingly with a good appetite, but the paleness and ghastly appearance of his countenance were much remarked. About three in the afternoon he was obliged to yield to the violence of his distemper; being seized with a great faintness, shivering, and headach, with other symptoms of a fever, which from that time never left him. Several physicians were called; but they differed much in their opinions, if indeed any agreement amongst them, considering the state of medicine at that time, could have been of service. On the first of November he was bled; an operation which Dr Butler, one of his physicians, had hitherto opposed, but now consented to in compliance with his fellows. The impropriety of it was manifest by the thin and dissolved state of the blood which was taken away, and still more by his becoming much worse next day. As at that time the Peruvian bark, the great antidote in putrid diseases, was unknown, and no proper methods of treatment seem to have been employed, it is not to be wondered that he sunk under the disease. Among other absurd remedies used on this occasion was "a cock cloven by the back, and applied to the soles of his feet." He expired on the 6th of November 1612, at the age of 18 years 8 months and 17 days. On opening his body, the lungs were found black, spotted, and full of corrupted matter; the diaphragm was also thickened in many places; the blood-vessels in the hinder part of the head were distended with blood, and the ventricles full of water: the liver was in some places pale and lead-coloured; the gall-bladder destitute of bile, and distended with wind; and the spleen in many places unnaturally black. His funeral was not solemnized till the 7th of December following. Many funeral sermons were published in honour of him, and the two universities published collections of verses on this occasion. The most emi-

Henry. nent poets of that age also exerted themselves in honour of the deceased prince; particularly Donne, Brown, Chapman, Drummond of Hawthornden, Dominic Baudius of Leyden, &c.

His highness's family continued together at St James's till the end of December 1612, when it was dissolved; and upon the day of their dissolution, Mr Joseph Hall, his chaplain, preached to them a most pathetic farewell sermon on Revel. xxi. 3. In this he speaks of his deceased master in the highest terms of commendation, as the glory of the nation, ornament of mankind, hope of posterity, &c.; and that he, who was compounded of all loveliness, had infused an harmony into his whole family, which was "the most loving and entire fellowship that ever met in the court of any prince." The exhortation, with which the preacher concludes, is: "Go in peace, and live as those that have lost such a master, and as those that serve a master whom they cannot lose."

Prince Henry was of a comely stature, about five feet eight inches; of a strong, straight, well-made body, with somewhat broad shoulders and a small waist; of an amiable and majestic countenance: his hair of an auburn colour; he was long-faced, and had a broad forehead, a piercing eye, a most gracious smile, with a terrible frown. He was courteous, loving, and affable; naturally modest, and even shame-faced; most patient, which he showed both in life and death; slow to anger, so that even when he was offended he would govern it and restrain himself to silence. He was merciful to offenders, after a little punishment to make them sensible of their faults. His sentiments of piety were strong and habitual; and his zeal for the interests of religion was such, that he would, if he had lived, have used his endeavours for reconciling the divisions among its professors. He usually retired three times a day for his private devotions, and was scarce once a month absent from the public prayers, where his behaviour was highly decent and exemplary, and his attention to the preacher the most fixed imaginable. He had the greatest esteem for all divines whose characters and conduct corresponded with their profession; but could not conceal his indignation against such as acted inconsistently with it, and he above all things abhorred flattery and vain-glory in them. He had a thorough detestation for popery, though he treated those of that religion with great courtesy; showing, that his hatred was not levelled at their persons, but their opinions. And he was so immoveable in his attachment to the Protestant religion, that not long before his death, as Sir Charles Cornwallis* assures us, he made a solemn protestation that he would never join in marriage with one of a different faith.

The prince was so exact in all the duties of filial piety, and bore so true a reverence and respect for the king his father, that though sometimes, out of his own inclination, or by the excitement of others, he moved his majesty in some things relating to the public, or his own particular interests, or those of others; yet upon the least word or look or sign given him of his majesty's disapprobation, he would instantly desist from pursuing the point, and return either with satisfaction upon finding it disagreeable to the king, or with such a resolved patience that he neither in word nor action gave so much as any appearance

* Discovers of the most illustrious Prince Henry, by Sir Charles Cornwallis, printed in the Harleian Miscellany, vol. iv.

p. 310.

Henry.

pearance of being displeas'd or discontented. He adhered strictly to justice on all occasions; and never suffer'd himself to determine rashly, or till after a due examination of both parties. This love of justice show'd itself very early by favouring and rewarding those among his pages and other young gentlemen, plac'd about him, who, by men of great judgment, were thought to be of the best behaviour and most meritorious. And when he was but a little above five years of age, and a son of the earl of Mar, somewhat younger than himself, falling out with some of his highness's pages, did him some wrong, the prince reprov'd him for it, saying, "I love you, because you are my lord's son, and my cousin: but if you be not better condition'd, I will love such a one better;" naming the child who had complain'd of him. He was of singular integrity, and hated flattery and dissimulation: the latter of which he esteem'd a base quality, especially in a prince: nor could he ever constrain himself to treat those kindly who did not deserve his love. A nobleman in the highest favour with the king, had written to him, by special command of his majesty, a letter, wherein he recommended to his highness a matter of very great consequence to be instantly answer'd; and in his subscription had used these words, "Yours before all the world." His highness directed Sir Charles Cornwallis to draw up an answer, who, having written it, added some words of favour to the nobleman to precede the prince's signing. His highness having read and consider'd the letter, allow'd it entirely without alteration: But with regard to the words of subscription, notwithstanding the great haste which the dispatch required, he order'd it to be new written, and the words object'd to by him to be left out; alleging, that he to whom he wrote had dealt with him untruly and unfaithfully, and that his hand should never affirm what his heart did not think. His temperance, except in the article of fruit, was as eminent as his abhorrence of vanity and ostentation, which began to show themselves when he was very young. When he was taught to handle the pike, and his master instructed him both by word and example to use a kind of stateliness in marching and holding of his hand; though he learn'd all other things, he would not conform himself to that affected fashion: and if sometimes, upon earnest intreaty, he offer'd to use it, he would laugh at himself, and presently return to his own more modest and decent manner. And though he was a perfect master of dancing, he never practis'd it except when he was strongly press'd to it. The same modesty appear'd in whatever he said or did: But it was no impediment to his generous and heroic disposition, which made him perform all his exercises best before much company and the greatest personages. His clothes were usually very plain, except on occasions of public ceremony, or upon receiving foreign ambassadors, when he would assume a magnificence of dress, and an air of majesty, which immediately after he laid aside. Having once worn a suit of Welsh frize for a considerable time, and being told that it was too mean for him, and that he ought not to keep even a rich suit so long; his answer was, that he was not ashamed of his country cloth, and wish'd that it would last for ever.

In quickness of apprehension and memory few of the

same age ever went beyond this prince; and fewer still in a right judgment of what he was taught. When he began to have some knowledge of the Latin tongue, being desir'd to choose a motto out of several sentences collect'd by his tutor for his use, after reading over many good ones, he pitch'd upon that of Silius Italicus, *Fax mentis honesta gloria*. And being ask'd by the king one day, which were the best verses that he had learn'd in the first book of Virgil's *Æneid*, he answer'd these:

*Rex erat Æneas nobis, quo justior alter
Nec pietate fuit, nec bello major & armis.*

Reading likewise another verse of the same poet,

Tros Tyriusve mihi nullo discrimine ugetur,

he said he would make use of it with this alteration,

Anglus Scotusve mihi nullo discrimine agetur.

Besides his knowledge of the learn'd languages, he spok'd the Italian and French; and had made a considerable progress in philosophy, history, fortification, mathematics, and cosmography; in the two last of which he was instructed by that excellent mathematician Mr Edward Wright. He lov'd and endeavour'd to do somewhat of every thing, and to be excellent in the most excellent. He greatly delight'd in all rare inventions and arts, and military engines both at land and sea; in shooting and levelling great pieces of ordnance; in the ordering and marshalling of armies; in building and gardening; in music, sculpture, and painting, in which last art he brought over several works of great masters from all countries.

He had a just opinion of the great abilities of Sir Walter Raleigh; and is report'd to have said, that, "no king but his father would keep such a bird in a cage." And it is affirm'd, that his highness, but a few months before his death, obtain'd the lands and castle of Sherburn in Dorsetshire, the confiscat'd estate of Sir Walter, with an intention of returning it to him. That eminent writer, soldier, and statesman, had a reciprocal regard for the prince, to whom he had design'd to address a discourse, "Of the Art of War by Sea," which his highness's death prevent'd the author from finishing. He had written likewise to the prince another "Discourse of a Maritimal Voyage, with the passages and incidents therein:" But this has never yet appear'd in print. He had also intend'd, and, as he expresses it, hewn out a second and third volume of his *General History*, which were to have been directed to his highness: "but it has pleas'd God (says he) to take that glorious prince out of this world, to whom they were directed; whose unspeakable and never-enough lamented loss hath taught me to say with Job, *Versa est in luctum cithara mea, & organum meum in vocem flentium.*"

In the government of his household and management of his revenues, though he was so very young, his example deserv'd to be imitat'd by all other princes. He not only gave orders, but saw almost every thing done himself: so that there were scarce any of his domestics whom he did not know by name. And among these there was not one even suspected papist; his directions being very peremptory for setting down the names of all communicants, that he might know if

Henry.

Henry. there were any of his family who did absent themselves from the communion. His family was large, consisting of few less than 500, many of them young gentlemen born to great fortunes, in the prime of their years, when their passions and appetites were strong, their reason weak, and their experience little. But his judgment, the gravity of his princely aspect, and his own example, were sufficient restraints upon them; his very eye served instead of a command; and his looks alone had more effect than the sharpest reprehensions of other princes. If any disputes or contests arose among his servants, he would put a stop to them at the beginning, by referring them to some of his principal officers, whom he thought most intelligent in points of that nature, and to understand best what compensation was due to the injured, and what reproof to the offender; so that in so numerous a family there was not so much as a blow given, nor any quarrel carried to the least height.

Though he loved plenty and magnificence in his house, he restrained them within the rules of frugality and moderation, as we have already noticed. By this economy he avoided the necessity of being rigid to his tenants, either by raising their farms or fines, or seeking or taking advantage of forfeitures. Nor was he tempted to make the profit which both law and right afforded him, of such who had in the time of former princes purchased lands belonging to his duchy of Cornwall, which could not by law be alienated from it; for he gave them, upon resuming these lands, a reasonable satisfaction. Neither did his economy restrain him from being liberal where merit or distress called for it; at the same time he was never known to give, or even promise, any thing, but upon mature deliberation. Whatever abuses were represented to him, he immediately redressed, to the entire satisfaction of the persons aggrieved. In his removal from one of his houses to another, and in his attendance on the king on the same occasions, or in progresses, he would suffer no provisions or carriages to be taken up for his use, without full contentment given to the parties. And he was so solicitous to prevent any person from being prejudiced or annoyed by himself or any of his train; that whenever he went out to hawk before harvest was ended, he would take care that none should pass through the corn; and, to set them an example, would himself ride rather a furlong about.

His speech was slow, and attended with some impediment, rather, as it was conceived, by custom and a long imitation of some who first instructed him, than by any defect of nature, as appeared from his having much corrected it by using at home amongst his servants, first short discourses, and then longer, as he found himself enabled to do it. Yet he would often say of himself, that he had the most unserviceable tongue of any man living.

He had a certain height of mind, and knew well how to keep his distance; which indeed he did to all, admitting no near approach either to his power or his secrets. He expressed himself, upon occasions offered, to love and esteem most such of the nobility as were most anciently descended, and most nobly and honestly disposed. He had an entire affection for his brother the duke of York, and his sister Elizabeth; though sometimes, by a kind of rough play with the former, and

an appearance of contradicting the latter in what he discerned her to desire, he took a pleasure in giving them, in their tender years, some exercise of their patience. A writer* of less authority than Sir Charles Cornwallis, from the latter of whom we have these particulars, adds, that the prince seemed to have more affection for his sister than his brother, whom he would often taunt till he made him weep, telling him that if he should be a bishop, a gown being fittest to hide his legs, which were subject in his childhood to be crooked.

With regard to any unlawful passion for women, to the temptations of which the prince's youth and situation peculiarly exposed him, his historian, who knew him, and observed him much, assures us, that having been present at great feasts made in the prince's house, to which he invited the most beautiful ladies of the court and city, he could not discover by his highness's behaviour, eyes, or countenance, the least appearance of a particular inclination to any one of them; nor was he at any other time witness of such words or actions as could justly be a ground of the least suspicion of his virtue; though he observes, that some persons of that time, measuring the prince by themselves, were pleased to conceive and report otherwise of him. It is indeed asserted by the writer of *Aulicus Coquinarius*, believed upon good grounds to be William Saunderson, Esq. author of the "Complete History of Mary Queen of Scotland, and her son and successor King James," that the prince made court to the countess of Essex (afterwards divorced from the earl, and married to the viscount Rochester), before any other lady then living. And Arthur Wilson mentions the many amorous glances which the prince gave her, till discovering that she was captivated with the growing fortunes of Lord Rochester, and grounded more hope upon him than the uncertain and hopeless love of his highness, he soon slighted her. The learned and pious antiquary, Sir Simonds D'Ewes, in a manuscript life of himself, written with his own hand, and brought down to the year 1637, is positive, that, "notwithstanding the inestimable Prince Henry's martial desires and initiation into the ways of godliness, the countess, being set on by the earl of Northampton her father's uncle, first caught his eye and heart, and afterwards prostituted herself to him, who first reaped the fruits of her virginity. But those sparks of grace which even then began to show their lustre in him, with those more heroic innate qualities derived from virtue, which gave the law to his more advised actions, soon raised him out of the slumber of that distemper, and taught him to reject her following temptations with indignation and superciliousness." But these authorities, Dr Birch observes, ought to have little weight to the prejudice of the prince's character, against the direct testimony in his favour from so well informed a writer as Sir Charles Cornwallis.

The immature death of the prince concurring with the public apprehensions of the power of the papists, and the ill opinion which the nation then had of the court, gave immediate rise to suspicions of its being hastened by poison. And these suspicions were heightened by the very little concern shown by some persons in great stations. "To tell you (says Richard earl of Dorset in a letter to Sir Thomas Edmondes, of the

Henry.
* Francis Osborne, *Traditional Memoirs on the Reign of King James*, sect. 45.

Henry. 23d of November 1612) that our rising sun is set ere scarcely he had shone, and that with him all our glory lies buried, you know and do lament as well as we, and better than some do, and more truly; or else you are not a man, and sensible of this kingdom's loss." And it is certain, that this loss made so little impression upon the king and his favourite, that the lord viscount Rochester on the 9th of November, three days after it, wrote to Sir Thomas Edmondes to begin a negotiation for a marriage between Prince Charles and the second daughter of France. But the ambassador, who had more sense of decency, thought it improper to enter upon such an affair so soon after the late prince's death. Mr Beaulieu, secretary to Sir Thomas Edmondes, in a letter of the 12th of November 1612, to Mr Trumbull, then resident at Brussels, after styling the prince "the flower of his house, the glory of his country, and the admiration of all strangers, which in all places had imprinted a great hope on the minds of the well affected, as it had already stricken terror into the hearts of his enemies," adds, "who perhaps (for of this lamentable accident we have yet no particular relation) fearing the growing virtues of that young prince, have used the traitorous venom of their abominable practices to cut him off in his youth. And this I do not apprehend without cause, considering the several advertisements which I saw a month ago coming out of England, Holland, and Calais, of strange rumours which were in these parts, of some great and imminent practice in hand, for the success whereof it was written, that in some places our adversaries had made solemn prayers: and out of Calais it was especially advertised, that in your parts they were in expectation of the death of some great prince. But, alas! we did little apprehend, that such ominous prognostications would have lighted upon the person of that vigorous young prince, whose extraordinary great parts and virtues made many men hope and believe, that God had reserved and destined him, as a chosen instrument, to be the standard-bearer of his quarrel in these miserable times, to work the restoration of his church, and the destruction of the Romish idolatry.

With the above notion his royal highness's mother the queen was peculiarly impressed, according to Dr Welwood; who, in his Notes on Arthur Wilson's Life of King James I. in the Complete History of England, p. 714. informs us, though without giving any authority, that when the prince fell into his last illness, the queen sent to Sir Walter Raleigh for some of his cordials, which she herself had taken some time before in a fever with remarkable success. Raleigh sent it, together with a letter to the queen, wherein he expressed a tender concern for the prince; and, boasting of his medicine, stumbled unluckily upon an expression to this purpose, "that it would certainly cure him or any other of a fever, except in case of poison." As the prince took this medicine, and died notwithstanding its virtues, the queen, in the agony of her grief, showed Raleigh's letter; and laid so much weight on the expression about poison, that as long as she lived she could never be persuaded but that the prince had died by that means. Sir Anthony Weldon* suggests that the prince was poisoned. The same notion is countenanced by Wilson in his History †; and was adopted by Dr Welwood, as already mentioned:

Henry. Who likewise, in another work, his *Memoirs*, after styling the prince "the darling of mankind, and a youth of vast hopes and wonderful virtues," remarks, that it was the general rumour at the time of his death, that his highness was poisoned; and that there is in print a sermon preached at St James's upon the dissolution of his family, that boldly insinuated some such thing. By this sermon Dr Welwood must mean that of Mr Hall cited above; in which, however, at least as it is reprinted in the London edition of his works in 1617, in folio, there is not to be found any expression that carries the least insinuation of that kind. The writer of the memoirs adds, that Sir Francis Bacon, in his speech at the trial of the earl of Somerset, had some reflections upon the intimacy of that lord with Sir Thomas Overbury, which seemed to point that way; there being several expressions left out of the printed copy that were in the speech. Bishop Burnet likewise tells us, that he was assured by Colonel Titus, that he had heard King Charles I. declare, that the prince his brother was poisoned by the means of the viscount Rochester, afterwards earl of Somerset. But it will be perhaps sufficient to oppose to all such suggestions the unanimous opinion of physicians who attended the prince during his sickness, and opened his body after his death; from which, as Dr Welwood himself observes, there can be no inference drawn that he was poisoned. To which may be added the authority of Sir Charles Cornwallis ‡, who was well informed, and above all suspicion in this point, and who pronounces the rumours spread of his highness's having been poisoned vain; and was fully convinced that his death was natural, and occasioned by a violent fever.

HENRY, *Philip*, a pious and learned nonconformist minister, was the son of Mr John Henry, page of the back-stairs to James duke of York, and was born at Whitehall in 1631. He was admitted into Westminster school at about 12 years of age; became the favourite of Dr Bushby, and was employed by him, with some others, in collecting materials for the Greek grammar he afterwards published. From thence he removed to Christ-church, Oxford; where, having obtained the degree of master of arts, he was taken into the family of Judge Puleston, at Emerald in Flintshire, as tutor to his sons, and to preach at Worthenbury. He soon after married the only daughter and heiress of Mr Daniel Matthews of Broad-oak near Whitchurch, by whom he became possessed of a competent estate. When the king and episcopacy were restored, he refused to conform, was ejected, and retired with his family to Broad-oak: here, and in the neighbourhood, he spent the remainder of his life, about 28 years, relieving the poor, employing the industrious, instructing the ignorant, and exercising every opportunity of doing good. His moderation in his unconfornity was eminent and exemplary; and upon all occasions he bore testimony against uncharitable and schismatical separation. In church-government he wished for Archbishop Usher's reduction of episcopacy. He thought it lawful to join in the common prayer in public assemblies; which, during the time of his silence and restraint, he commonly attended with his family with reverence and devotion.

HENRY, *Matthew*, an eminent dissenting minister and author, was the son of the former, and was born

† *Life and Death of Henry*, p. 81. 82.

* *Court and Character of S. James*, p. 77. 78. P. 62. 63.

Henry. in the year 1662. He continued under his father's care till he was 18 years of age; in which time he became well skilled in the learned languages, especially in the Hebrew, which his father had rendered familiar to him from his childhood; and from first to last the study of the Scriptures was his most delightful employment. He completed his education in an academy kept at Islington by Mr Doolittle, and was afterwards entered in Gray's Inn for the study of the law; where he became well acquainted with the civil and municipal law of his own country, and from his application and great abilities it was thought he would have become very eminent in that profession. But at length, resolving to devote his life to the study of divinity, in 1685 he retired into the country, and was chosen pastor of a congregation at Chester, where he lived about 25 years, greatly esteemed and beloved by his people. He had several calls from London, which he constantly declined; but was at last prevailed upon to accept an unanimous invitation from a congregation at Hackney. He wrote, 1. Expositions of the Bible, in 5 vols. folio. 2. The life of Mr Philip Henry. 3. Directions for daily communion with God. 4. A method for prayer. 5. Four discourses against vice and immorality. 6. The communicant's companion. 7. Family hymns. 8. A scriptural catechism. And 9. A discourse concerning the nature of schism. He died of an apoplexy at Nantwich, when upon a journey, in 1714; and was interred at Trinity-church in Chester.

HENRY, *Dr Robert*, author of the "History of Great Britain, written on a new plan," was the son of James Henry farmer at Muirtown in the parish of St Ninian's, North Britain, and of Jean Galloway daughter of ——— Galloway of Burrowmeadow in Stirlingshire. He was born on the 18th of February 1718; and having early resolved to devote himself to a literary profession, was educated first under a Mr John Nicolson at the parish-school of St Ninians, and for some time at the grammar-school of Stirling. He completed his course of academical study at the university of Edinburgh, and afterwards became master of the grammar-school of Annan. He was licensed to preach on the 27th of March 1746, and was the first licentiate of the presbytery of Annan after its erection into a separate presbytery. Soon after, he received a call from a congregation of Presbyterian dissenters at Carlisle, where he was ordained in November 1748. In this station he remained 12 years, and on the 13th of August 1760 became pastor of a dissenting congregation in Berwick upon Tweed. Here he married, in 1763, Ann Balderston daughter of Thomas Balderston surgeon in Berwick; by whom he had no children, but with whom he enjoyed to the end of his life a large share of domestic happiness. He was removed from Berwick to be one of the ministers of Edinburgh in November 1768; was minister of the church of the New Grey Friars from that time till November 1776; and then became colleague-minister in the Old church, and remained in that station till his death. The degree of Doctor in Divinity was conferred on him by the university of Edinburgh in 1770; and in 1774 he was unanimously chosen moderator of the general assembly of the church of Scotland, and is the only person on record who obtained

that distinction the first time he was a member of assembly. Henry.

From these facts, which contain the outlines of Dr Henry's life, few events can be expected to suit the purpose of the biographer. Though he must have been always distinguished among his private friends, till he was translated to Edinburgh he had few opportunities of being known to the public. The composition of sermons must have occupied a chief part of his time during his residence at Carlisle, as his industry in that station is known to have rendered his labours in this department easy to him during the rest of his life. But even there he found leisure for other studies; and the knowledge of classical literature, in which he eminently excelled, soon enabled him to acquire an extent of information which qualified him for something more important than he had hitherto in his view.

Soon after his removal to Berwick, he published a scheme for raising a fund for the benefit of the widows and orphans of Protestant dissenting ministers in the north of England. This idea was probably suggested by the prosperity of the fund which had almost 30 years before been established for a provision to ministers widows, &c. in Scotland. But the situations of the clergy of Scotland were very different from the circumstances of dissenting ministers in England. Annuities and provisions were to be secured to the families of dissenters, without subjecting the individuals (as in Scotland) to a proportional annual contribution, and without such means of creating a fund as could be the subject of an act of parliament to secure the annual payments. The acuteness and activity of Dr Henry surmounted these difficulties; and, chiefly by his exertions, this useful and benevolent institution commenced about the year 1762. The management was entrusted to him for several years; and its success has exceeded the most sanguine expectations which were formed of it. The plan itself, now sufficiently known, it is unnecessary to explain minutely. But it is mentioned here, because Dr Henry was accustomed in the last years of his life to speak of this institution with peculiar affection, and to reflect on its progress and utility with that kind of satisfaction which a good man can only receive from "the labour of love and of good works."

It was probably about the year 1763 that he first conceived the idea of his History of Great Britain: a work already established in the public opinion; and which will certainly be regarded by posterity, not only as a book which has greatly enlarged the sphere of history, and gratifies our curiosity on a variety of subjects which fall not within the limits prescribed by preceding historians, but as one of the most accurate and authentic repositories of historical information which this country has produced. The plan adopted by Dr Henry, which is indisputably his own, and its peculiar advantages, are sufficiently explained in his general preface. In every period, it arranges, under separate heads or chapters, the civil and military history of Great Britain; the history of religion; the history of our constitution, government, laws, and courts of justice; the history of learning, of learned men, and of the chief seminaries of learning; the history of arts; the history of commerce, of shipping, of money or coin, and of the price of commodities; and the history

Henry. of manners, virtues, vices, customs, language, dress, diet, and amusements. Under these seven heads, which extend the province of an historian greatly beyond its usual limits, every thing curious or interesting in the history of any country may be comprehended. But it certainly required more than a common share of literary courage to attempt on so large a scale a subject so intricate and extensive as the history of Britain from the invasion of Julius Cæsar. That Dr Henry neither overrated his powers nor his industry, could only have been proved by the success and reputation of his works.

But he soon found that his residence at Berwick was an insuperable obstacle in the minute researches which the execution of his plan required. His situation there excluded him from the means of consulting the original authorities; and though he attempted to find access to them by means of his literary friends, and with their assistance made some progress in his work, his information was notwithstanding so incomplete, that he found it impossible to prosecute his plan to his own satisfaction, and was at last compelled to relinquish it.

By the friendship of Gilbert Laurie, Esq. lord provost of Edinburgh, and one of his majesty's commissioners of excise in Scotland, who had married the sister of Mrs Henry, he was removed to Edinburgh in 1768; and it is to this event that the public are indebted for his prosecution of the History of Great Britain. His access to the public libraries, and the means of supplying the materials which these did not afford him, were from that time used with so much diligence and perseverance, that the first volume of his History in quarto was published in 1771, the second in 1774, the third in 1777, the fourth in 1781, and the fifth (which brings down the History to the accession of Henry VII.) in 1785. The subject of these volumes comprehends the most intricate and obscure periods of our history; and when we consider the scanty and scattered materials which Dr Henry has digested, and the accurate and minute information which he has given us under every chapter of the work, we must have a high opinion both of the learning and industry of the author, and of the vigour and activity of his mind: especially when it is added, that he employed no amanuensis, but completed the manuscript with his own hand; and that, excepting the first volume, the whole book, such as it is, was printed from the original copy. Whatever corrections were made on it, were inserted by interlineations, or in revising the proof sheets. He found it necessary, indeed, to confine himself to a first copy, from an unfortunate tremor in his hand, which made writing extremely inconvenient, which obliged him to write with his paper on a book placed on his knee instead of a table, and which unhappily increased to such a degree that in the last years of his life he was often unable to take his victuals without assistance. An attempt which he made after the publication of the fifth volume to employ an amanuensis did not succeed. Never having been accustomed to dictate his compositions, he found it impossible to acquire a new habit; and though he persevered but a few days in the attempt, it had a sensible effect on his health, which he never afterwards recovered.—An author has no right to claim indul-

VOL. X. Part I.

gence, and is still less intitled to credit, from the public, for any thing which can be ascribed to negligence in committing his manuscripts to the press; but considering the difficulties which Dr Henry surmounted, and the accurate research and information which distinguish his history, the circumstances which have been mentioned are far from being uninteresting, and must add considerably to the opinion formed of his merit among men who are judges of what he has done. He did not profess to study the ornaments of language; but his arrangement is uniformly regular and natural, and his style simple and perspicuous. More than this he has not attempted, and this cannot be denied him. He believed that the time which might be spent in polishing or rounding a sentence, was more usefully employed in investigating and ascertaining a fact: And, as a hook of facts and solid information, supported by authentic documents, his history will stand a comparison with any other history of the same period.

But Dr Henry had other difficulties to surmount than those which related to the composition of his work. Not having been able to transact with the booksellers to his satisfaction, the five volumes were originally published at the risk of the author. When the first volume appeared, it was censured with an unexampled acrimony and perseverance. Magazines, reviews, and even newspapers, were filled with abusive remarks and invectives, in which both the author and the book were treated with contempt and scurrility. When an author has once submitted his works to the public, he has no right to complain of the just severity of criticism. But Dr Henry had to contend with the inveterate scorn of malignity. In compliance with the usual custom, he had permitted a sermon to be published which he had preached before the society in Scotland for propagating Christian knowledge in 1773; a composition containing plain good sense on a common subject, from which he expected no reputation. This was eagerly seized on by the adversaries of his History, and torn to pieces with a virulence and asperity which no want of merit in the sermon could justify or explain. An anonymous letter had appeared in a newspaper to vindicate the History from some of the unjust censures which had been published, and asserting from the real merit and accuracy of the book the author's title to the approbation of the public. An answer appeared in the course of the following week, charging him, in terms equally confident and indecent, with having written this letter in his own praise. The efforts of malignity seldom fail to defeat their purpose, and to recoil on those who direct them. Dr Henry had many friends, and till lately had not discovered that he had any enemies. But the author of the anonymous vindication was unknown to him, till the learned and respectable Dr Macqueen, from the indignation excited by the confident petulance of the answer, informed him that the letter had been written by him. These anecdotes are still remembered. The abuse of the History, which began in Scotland, was renewed in some of the periodical publications in South Britain; though it is justice to add (without meaning to refer to the candid observations of English critics), that in both kingdoms the asperity originated in the same quarter, and that paragraphs and criticisms written at Edinburgh were printed in London. The same

Henry.

Henry. spirit appeared in *Strictures* published on the second and third volumes; but by this time it had in a great measure lost the attention of the public. The malevolence was sufficiently understood, and had long before become fatal to the circulation of the periodical paper from which it originally proceeded. The book, though printed for the author, had sold beyond his most sanguine expectations; and had received both praise and patronage from men of the first literary characters in the kingdom: and though, from the alarm which had been raised, the booksellers did not venture to purchase the property till after the publication of the fifth volume, the work was established in the opinion of the public, and at last rewarded the author with a high degree of celebrity, which he happily lived to enjoy.

In an article relating to Dr Henry's life, not to have mentioned the opposition which his *History* encountered, would have been both affectation and injustice. The facts are sufficiently remembered, and are unfortunately too recent to be more minutely explained. That they contributed at first to retard the sale of the work is undeniable, and may be told without regret now that its reputation is established. The book has raised itself to eminence as a *History of Great Britain* by its own merits; and the means employed to obstruct its progress have only served to embellish its success.

Dr Henry was no doubt encouraged from the first by the decided approbation of some of his literary friends, who were allowed to be the most competent judges of his subject; and in particular by one of the most eminent historians of the present age, whose history of the same periods justly possesses the highest reputation. The following character of the first and second volumes was drawn up by that gentleman, and is well intitled to be inserted in a narrative of Dr Henry's life. "Those who profess a high esteem for the first volume of Dr Henry's history, I may venture to say, are almost as numerous as those who have perused it, provided they be competent judges of a work of that nature, and are acquainted with the difficulties which attend such an undertaking. Many of those who had been so well pleased with the first were impatient to see the second volume, which advances into a field more delicate and interesting; but the Doctor hath shown the maturity of his judgment, as in all the rest, so particularly in giving no performance to the public that might appear crude or hasty, or composed before he had fully collected and digested the materials. I venture with great sincerity to recommend this volume to the perusal of every curious reader who desires to know the state of Great Britain in a period which was hitherto been regarded as very obscure, ill supplied with writers, and not possessed of a single one that deserves the appellation of a good one. It is wonderful what an instructive, and even entertaining, book the Doctor has been able to compose from such unpromising materials: *Tantum series juncturaque pollet*. When we see those barbarous ages delineated by so able a pen, we admire the oddness and singularity of the manners, customs, and opinions, of the times, and seem to be introduced into a new world; but we are still more surprised, as well as interested, when we reflect that those strange personages were the ancestors of the pre-

Henry. sent inhabitants of this island.—The object of an antiquary hath been commonly distinguished from that of an historian; for though the latter should enter into the province of the former, it is thought that it should only be *quanto basta*, that is, so far as is necessary, without comprehending all the minute disquisitions which give such supreme pleasure to the mere antiquary. Our learned author hath fully reconciled these two characters. His historical narrative is as full as those remote times seem to demand, and at the same time his inquiries of the antiquarian kind omit nothing which can be an object of doubt or curiosity. The one as well as the other is delivered with great perspicuity, and no less propriety, which are the true ornaments of this kind of writing. All superfluous embellishments are avoided; and the reader will hardly find in our language any performance that unites together so perfectly the two great points of entertainment and instruction."—The gentleman who wrote this character died before the publication of the third volume.—The progress of his work introduced Dr Henry to more extensive patronage, and in particular to the notice and esteem of the earl of Mansfield. That venerable nobleman, who is so well intitled to the gratitude and admiration of his country, thought the merit of Dr Henry's history so considerable, that, without any solicitation, after the publication of the fourth volume, he applied personally to his majesty to bestow on the author some mark of his royal favour. In consequence of this, Dr Henry was informed by a letter from Lord Stormont, the secretary of state, of his majesty's intention to confer on him an annual pension for life of 100l. "considering his distinguished talents and great literary merit, and the importance of the very useful and laborious work in which he was so successfully engaged, as titles to his royal countenance and favour." The warrant was issued on the 28th of May 1781; and his right to the pension commenced from the 5th of April preceding. This pension he enjoyed till his death, and always considered it as inferring a new obligation to persevere steadily in the prosecution of his work. From the earl of Mansfield he received many other testimonies of esteem both as a man and as an author, which he was often heard to mention with the most affectionate gratitude. The octavo edition of his history, published in 1778, was inscribed to his lordship. The quarto edition had been dedicated to the king.

The property of the work had hitherto remained with himself. But in April 1786, when an octavo edition was intended, he conveyed the property to Messrs Cadell and Strachan; reserving to himself what still remained unsold of the quarto edition, which did not then exceed eighty-one complete sets. A few copies were afterwards printed of the volumes of which the first impression was exhausted, to make up additional sets: and before the end of 1786, he sold the whole to Messrs Cadell and Strachan. By the first transaction he was to receive 1000l. and by the second betwixt 300l. and 400l.: about 1400l. in all. These sums may not be absolutely exact, as they are set down from memory; but there cannot be a mistake of any consequence on the one side or the other.—Dr Henry had kept very accurate accounts of the sales from the time of the original publication; and after

Henry par Sulphuris. ter his last transaction with Messrs Cadell and Strachan, he found that his real profits had amounted in whole to about 3300 pounds; a striking proof of the intrinsic merit of a work which had forced its way to the public esteem unprotected by the interest of the booksellers, and in spite of the malignant opposition with which the first volume had to struggle.

The prosecution of his history had been Dr Henry's favourite object for almost 30 years of his life. He had naturally a sound constitution, and a more equal and larger portion of animal spirits than is commonly possessed by literary men. But from the year 1785 his bodily strength was sensibly impaired. Notwithstanding this, he persisted steadily in preparing his sixth volume, which brings down the history to the accession of Edward VI. The materials of this volume were left in the hands of his executors almost completed. Scarcely any thing remained unfinished but the two short chapters on arts and manners; and even for these he had left materials and authorities so distinctly collected, that there was no great difficulty in supplying what was wanting. This sixth volume was published in the year 1793, with a life of the author prefixed; and it was found intitled to the same favourable reception from the public which had been given to the former volumes. It was written under the disadvantages of bad health and great weakness of body. The tremulous motion of his hand had increased so as to render writing much more difficult to him than it had ever been; but the vigour of his mind and his ardour were unimpaired; and independent of the general character of his works, the posthumous volume will be a lasting monument of the strength of his faculties, and of the literary industry and perseverance which ended only with his life.

Dr Henry's original plan extended from the invasion of Britain by the Romans to the present times. And men of literary curiosity must regret that he did not live to complete his design; but he has certainly finished the most difficult parts of his subject. The periods after the accession of Edward VI. afford materials more ample, better digested, and much more within the reach of common readers.

Till the summer of 1790 he was able to pursue his studies, though not without some interruptions. But at that time his health greatly declined; and, with a constitution quite worn out, he died on the 24th of November of that year, in the 73d year of his age.

HENTINGS, in *Agriculture*, a term used by the farmers for a particular method of sowing before the plough. The corn being cast in a straight line just where the plough is to come, is by this means presently ploughed in. By this way of sowing they think they save a great deal of seed and other charge, a dexterous boy being as capable of sowing this way out of his hat as the most skilful seedsman.

HENTING is also a term used by the ploughmen, and others, to signify the two furrows that are turned from one another at the bottom, in the ploughing of a ridge. The word seems to be a corruption of ending, because those furrows made an end of ploughing the ridges. The tops of the ridges they call *veerings*.

HEPAR-SULPHURIS, or *Liver of Sulphur*, a combination of alkaline salt and sulphur. See SULPHURET; CHEMISTRY, N^o 918. and 1029.

HEPATIC, in *Medicine and Anatomy*, any thing belonging to the liver.

HEPATIC Air, or *Sulphurated Hydrogen Gas*, a permanently elastic fluid of a very disagreeable odour, somewhat like that of rotten eggs. See CHEMISTRY, N^o 442.

HEPATIC Aloes, the inspissated juice of a species of ALOE. See MATERIA MEDICA *Index*.

HEPATIC Stone. See LIVER Stone.

HEPATIC Water. See SULPHUREOUS WATERS, CHEMISTRY, p. 706.

HEPATICA, a species of ANEMONE. See BOTANY *Index*.

HEPATITIS, in *Medicine*, an inflammation of the liver. See MEDICINE *Index*.

HEPATOSCOPIA, (formed of *ἥπαρ liver*, and *σκοπεω, I consider*), in antiquity, a species of divination, wherein predictions were made by inspecting the livers of animals.

HEPATOSCOPIA is also used as a general name for divination by entrails.

HEPHÆSTIA, in Grecian antiquity, an Athenian festival in honour of Vulcan, the chief ceremony of which was a race with torches. It was performed in this manner: The antagonists were three young men, one of whom, by lot, took a lighted torch in his hand, and began his course; if the torch was extinguished before he finished the race, he delivered it to the second; and he in like manner to the third: the victory was his who first carried the torch lighted to the end of the race; and to this successive delivering of the torch we find many allusions in ancient writers.

HEPHTHEMIMERIS (composed of *ἑπτα, seven*, *ἡμις, half*, and *μετρος, part*), in the Greek and Latin poetry, a sort of verse consisting of three feet and a syllable; that is, of seven half feet.

Such are most of the verses in Anacreon:

Θεω	λογου	Ατρου	δαι
Θεω	δε Καδ	μου α	δαι, &c.

And that of Aristophanes, in his *Plutus*:

Επιθε μετροι χυροι.

They are also called *trimetri catalectici*.

HEPHTHEMIMERIS, or *Hepthemimeres*, is also a cæsura after the third foot; that is, on the seventh half-foot. It is a rule, that this syllable, though it be short in itself, must be made long on account of the cæsura, or to make it an *Hepthemimeris*. As in that verse of Virgil,

Et furis agitated amor, et conscia virtus.

It may be added, that the cæsura is not to be on the fifth foot, as it is in the verse which Dr Harris gives us for an example:

Ille latus niveum molli sultus Hyacintho.

This is not a heptthemimeris cæsura, but a hennemimeris, i. e. of nine half feet.

HEPTACHORD, in the ancient poetry, signified verses that were sung or played on seven chords, that is, on seven different notes. In this sense it was applied to the lyre when it had but seven strings. One of the intervals is also called an *heptachord*, as containing

Hepta-
chord
||
Heracleon.

taining the same number of degrees between the extremes.

HEPTAGON, in *Geometry*, a figure consisting of seven sides and as many angles. In fortification, a place is termed a *heptagon*, that has seven bastions for its defence.

HEPTAGONAL NUMBERS, in *Arithmetic*, a sort of polygonal numbers, wherein the difference of the terms of the corresponding arithmetical progression is 5. One of the properties of these numbers is, that if they be multiplied by 40, and 9 be added to the product, the sum will be a square number.

HEPTANDRIA, in *Botany*, (from *hepta*, *septem*, and *andria*, *a man*); the seventh class in Linnæus's sexual method, consisting of plants with hermaphrodite flowers, which have seven stamens or male organs. See Classification under **BOTANY**.

HEPTANGULAR, in *Geometry*, an appellation given to figures which have seven angles.

HEPTARCHY (compounded of the Greek *hepta*, "seven," and *arche*, *imperium*, "government"), a government composed of seven persons, or a country governed by seven persons, or divided into seven kingdoms.

The Saxon heptarchy included all England, which was cantoned out into seven independent petty kingdoms, peopled and governed by different clans and colonies, viz. those of Kent, the South Saxons, West Saxons, East Saxons, Northumberland, the East Angles, and Mercia. The heptarchy was formed by degrees from the year 455, when first the kingdom of Kent was erected, and Hengist assumed the title of king of Kent immediately after the battle of Eglesford; and it terminated in 827 or 828, when King Egbert terminated them into one, made the heptarchy into a monarchy, and assumed the title of king of England. It must be observed, however, that though Egbert became monarch of England, he was not perfectly absolute. The kingdom which he actually possessed consisted of the ancient kingdoms of Wessex, Sussex, Kent, and Essex, that had been peopled by Saxons and Jutes. As for the other three kingdoms, whose inhabitants were Angles, he contented himself with preserving the sovereignty over them, permitting them to be governed by kings who were his vassals and tributaries.

The government of the heptarchy, reckoning from the founding of the kingdom of Mercia, the last of the seven Anglo-Saxon kingdoms, lasted 243 years; but if the time spent by the Saxons in their conquests from the arrival of Hengist in 449 be added, the heptarchy will be found to have lasted 378 years from its commencement to its dissolution. The causes of the dissolution of the heptarchy were the great inequality among the seven kingdoms, three of which greatly surpassed the others in extent and power; the default of male heirs in the royal families of all the kingdoms, that of Wessex excepted; and the concurrence of various circumstances which combined in the time of Egbert.

HERACLEA, an ancient city of Turkey in Europe, and in Romania, with the see of an archbishop of the Grecian church, and a sea-port. It was a very famous place in former times, and there are still some remains of its ancient splendour. Theodore Lascaris took it from David Comnenus, emperor of Trebisond, when

it fell into the hands of the Genoese, but Mahomet II. took it from them; since which time it has been in the possession of the Turks. It is near the sea. E. Long. 27. 58. N. Lat. 40. 59.

Heracles
||
Heracleidæ.

HERACLEONITES, a sect of Christians, the followers of Heracleon, who refined upon the Gnostic divinity, and maintained that the world was not the immediate production of the Son of God, but that he was only the occasional cause of its being created by the demiurgus. The Heracleonites denied the authority of the prophecies of the Old Testament, maintaining that they were mere random sounds in the air; and that St John the Baptist was the only true voice that directed to the Messiah.

HERACLEUM, MADNESS, or *Hogweed*; a genus of plants belonging to the pentandria class; and in the natural method ranking under the 45th order, *Umbellata*. See **BOTANY Index**.

HERACLIDÆ, the descendants of Hercules, greatly celebrated in ancient history. Hercules at his death left to his son Hyllus all the rights and demands which he had upon the Peloponnesus, and permitted him to marry Iole as soon as he came of age. The posterity of Hercules were not more kindly treated by Euristheus than their father had been, and they were obliged to retire for protection to the court of Ceyx, king of Trachinia. Euristheus pursued them thither; and Ceyx, afraid of his resentment, begged the Heracleidæ to depart from his dominions. From Trachinia they came to Athens, where Theseus, the king of the country, who had accompanied their father in some of his expeditions, received them with great humanity, and assisted them against their common enemy Euristheus. Euristheus was killed by the hand of Hyllus himself, and his children perished with him, and all the cities of the Peloponnesus became the undisputed property of the Heracleidæ. Their triumph, however, was short; their numbers were lessened by a pestilence; and the oracle informed them, that they had taken possession of the Peloponnesus before the gods permitted their return. Upon this they abandoned Peloponnesus, and came to settle in the territories of the Athenians, where Hyllus, obedient to his father's commands, married Iole the daughter of Eurytus. Soon after he consulted the oracle, anxious to recover the Peloponnesus; and the ambiguity of the answer determined him to make a second attempt. He challenged to single combat Atreus, the successor of Euristheus on the throne of Mycense; and it was mutually agreed that the undisturbed possession of the Peloponnesus should be ceded to whosoever defeated his adversary. Echemus accepted the challenge for Atreus, and Hyllus was killed, and the Heracleidæ a second time departed from Peloponnesus. Cleodæus the son of Hyllus made a third attempt, and was equally unsuccessful; and his son Aristomachus some time after met with the same unfavourable reception, and perished in the field of battle. Aristodemus, Temenus, and Chresphontes, the three sons of Aristomachus, encouraged by the more expressive word of an oracle, and desirous to revenge the death of their progenitors, assembled a numerous force, and with a fleet invaded all Peloponnesus. Their expedition was attended with much success; and after some decisive battles, they became masters of all the peninsula. The recovery of the Peloponnesus by the descendants of Hercules.

Heracleida
Heraclius

cles forms an interesting epoch in ancient history, which is universally believed to have happened 80 years after the Trojan war, or 1190 years before the Christian era. This conquest was totally achieved about 120 years after the first attempt of Hyllus, who was killed about 20 years before the Trojan war. As it occasioned a world of changes and revolutions in the affairs of Greece, insomuch that scarce a state or people but were turned upside down thereby, the return of the Heracleidæ is the epocha of the beginning of profane history: all the time that preceded it is reputed fabulous. Accordingly, Ephorus, Cumanus, Calisthenes, and Theopompus, only begin their histories from hence.

HERACLIDES of PONTUS, a Greek philosopher, the disciple of Speusippus, and afterwards of Aristotle, flourished about 336 B. C. His vanity prompted him to desire one of his friends to put a serpent into his bed just as he was dead, in order to raise a belief that he was ascended to the heavens among the gods: but the cheat was discovered. All his works are lost.

HERACLITUS, a famous Ephesian philosopher, who flourished about the 69th Olympiad, in the time of Darius Hystaspes. He is said to have continually bewailed the wicked lives of men, and, as often as he came among them, to have fallen a-weeping; contrary to Democritus, who made the follies of mankind a subject of laughter. He retired to the temple of Diana, and played at dice with the boys there; saying to the Ephesians who gathered round him, "Worst of men, what do you wonder at! Is it not better to do thus than to govern you?" Darius wrote to this philosopher to come and live with him; but he refused the offer: at last, out of hatred to mankind, he retired to the mountains, where he contracted a dropsy by living on herbs, which destroyed him at 68 years of age. His writings gained him so great reputation, that his followers were called *Heraclitians*. Laertius speaks of a treatise upon nature, divided into three books, one concerning the universe, the second political, the third theological. This book he deposited in the temple of Diana; and it is said, that he affected to write obscurely, lest it should be read by the vulgar, and become contemptible. The fundamental doctrine of his philosophy was, that fire is the principle of all things; and the ancient philosophers have collected and preserved admirable apophthegms of this philosopher.

HERACLIUS, an eastern emperor, was descended from a Cappadocian family, who was sent to subdue the tyrant Phocas, whom he totally vanquished in 610. In consequence of this victory, young Heraclius was raised to the throne by the suffrages of the senate and people. He confined Crispus, the son-in-law of Phocas, in a monastery, whose defection had contributed to his success. Having humbly requested peace from the Persian monarch, who was extending his conquests all over the Asiatic part of the empire, his exorbitant and unjust conditions so exasperated Heraclius, that at once he started from inglorious ease to a conspicuous hero, raised a considerable army by vast exertions, conquered the king of Persia, and established his winter-quarters on the banks of the Halys. He next year penetrated into the very heart of Persia, and having resisted the attack of a threefold army of Persians, he surprised the town of Salban.

Another of his expeditions was against the Tigris, and he fought a battle near the site of the ancient Nineveh in 627, about the end of the year, at which time he gained a complete victory over the Persians, having slain three of their chiefs with his own hand. He recovered 300 Roman standards, and set a vast number of captives at liberty. In 628, he made the Persian king put an end to the persecution of the Christians, renounce the conquests of his father upon the Roman empire, and restore the true cross taken from Jerusalem. When at Emesa, he first heard of the name of Mahomet, who invited him to embrace his new faith, but without success. He brought a reproach on his name by adhering to the doctrine of the Monothelites, but chiefly by espousing his niece Martina for his second wife, by whose influence he divided the succession between Constantine and Heracleonas, his son by Martina. He fell into a dropsical complaint, by which he was carried off in the month of February 641, in the 31st year of his reign.

HERALD, says Verstegan, is derived from the Saxon word *Herhauk*, and by abbreviation *Herald*, which in that language signifies the champion of an army; and, growing to be a name of office, it was given to him who, in the army, had the special charge to denounce war, to challenge to battle and combat, to proclaim peace, and to execute martial messages. But the business of heralds with us is as follows, viz. to marshal, order, and conduct all royal cavalcades, ceremonies at coronations, royal marriages, installations, creations of dukes, marquises, earls, viscounts, barons, baronets, and dubbing of knights; embassies, funeral processions, declarations of war, proclamations of peace, &c.; to record and blazon the arms of the nobility and gentry; and to regulate any abuses therein through the English dominions, under the authority of the earl marshal, to whom they are subservient. The office of Windsor, Chester, Richmond, Somerset, York, and Lancaster heralds, is to be assistants to the kings-at-arms, in the different branches of their office: and they are superior to each other, according to creation, in the above order.

Heralds were formerly held in much greater esteem than they are at present; and were created and christened by the king, who, pouring a gold-cup of wine on their head, gave them the herald-name: but this is now done by the earl marshal. They could not arrive at the dignity of herald without having been seven years pursuivant; nor could they quit the office of herald, but to be made king-at-arms.

Richard III. was the first who formed them, in this kingdom, into a college; and afterwards great privileges were granted them by Edward VI. and Philip and Mary.

The origin of heralds is very ancient. Stentor is represented by Homer as herald of the Greeks, who had a voice louder than 50 men together. The Greeks called them *αγγελος*, and *αγγελουαυς*; and the Romans, *faciales*. The Romans had a college of heralds, appointed to decide whether a war were just or unjust; and to prevent its coming to open hostilities, till all means had been attempted for deciding the difference in a pacific way.

HERALDRY,

HERALDRY,

Definition,
origin, &c.
of Heraldry.

A SCIENCE which teaches how to blazon, or explain in proper terms, all that belongs to coats-of-arms; and how to marshal, or dispose regularly, divers arms on a field. It also teaches whatever relates to the marshalling of solemn cavalcades, processions, and other public ceremonies at coronations, installations, creations of peers, nuptials, christening of princes, funerals, &c.

Arms, or coats-of-arms, are hereditary marks of honour, made up of fixed and determined colours and figures, granted by sovereign princes, as a reward for military valour, a shining virtue, or a signal public service; and which serve to denote the descent and alliance of the bearer, or to distinguish states, cities, societies, &c. civil, ecclesiastical, and military.

Thus heraldry is the science, of which *arms* are the proper object; but yet they differ much both in their origin and antiquity. Heraldry, according to Sir George Mackenzie, "as digested into an art, and subjected to rules, must be ascribed to Charlemagne and Frederick Barbarossa, for it did begin and grow with the feudal law." Sir John Ferne is of opinion, that we did borrow *arms* from the Egyptians; meaning, from their hieroglyphics. Sir William Dugdale mentions, that arms, as marks of honour, were used by great commanders in war, necessity requiring that their persons should be notified to their friends and followers. The learned Alexander Nisbet, in his excellent system of heraldry, says, that arms owe their rise and beginning to the light of nature, and that signs and marks of honour were made use of in the first ages of the world, and by all nations, however simple and illiterate, to distinguish the noble from the ignoble. We find in Homer, Virgil, and Ovid, that their heroes had divers figures on their shields, whereby their persons were distinctly known. Alexander the Great, desirous to honour those of his captains and soldiers who had done any glorious action, and also to excite an emulation among the rest, did grant them certain badges to be borne on their armour, pennons, and banners, ordering, at the same time, that no person or potentate, through his empire, should attempt or presume to give or tolerate the bearing of those signs upon the armour of any man, but it should be a power reserved to himself; which prerogative has been claimed ever since by all other kings and sovereign princes within their dominions.

After these and many other different opinions, all that can be said with any certainty is, that in all ages, men have made use of figures of living creatures, or symbolical signs, to denote the bravery and courage either of their chief or nation, to render themselves the more terrible to their enemies, and even to distinguish themselves or families, as names do individuals. The famous C. Agrippa, in his treatise of the vanity of sciences, cap. 81. has collected many instances of these marks of distinction, anciently borne by kingdoms and states that were any way civilized, viz.

The Egyptians The Athenians The Goths The Romans The Franks The Saxons	}	borne	{ an ox, an owl, a bear, an eagle, a lion, a horse.
---	---	-------	--

Hereditary
Arms, &c.

The last is still borne in the arms of his present Britanic majesty. As to hereditary arms of families, William Camden, Sir Henry Spelman, and other judicious heralds, agree, that they began no sooner than towards the latter end of the 11th century. According to Father Menestrier's opinion, a French writer, whose authority is of great weight in this matter, Henry l'Oiseleur (the Falconer) who was raised to the imperial throne of the West in 920, by regulating tournaments in Germany gave occasion to the establishment of family-arms, or hereditary marks of honour, which undeniably are more ancient and better observed among the Germans than in any other nation. Moreover, this last author asserts, that with tournaments first came up coats-of-arms; which were a sort of livery, made up of several lists, fillets, or narrow pieces of stuff of divers colours, from whence came the fess, the bend, the pale, &c. which were the original charges of family-arms; for they who never had been at tournaments, had not such marks of distinction. They who inlisted themselves in the Croisades, took up also several new figures hitherto unknown in armorial ensigns; such as alerians, bezants, escalop-shells, martlets, &c. but more particularly crosses, of different colours for distinction's sake. From this it may be concluded, that heraldry, like most human inventions, was insensibly introduced and established; and that, after having been rude and unsettled for many ages, it was at last methodised, perfected, and fixed, by the Croisades and tournaments.

These marks of honour are called *arms*, from their being principally and first worn by military men at war and tournaments, who had them engraved, embossed, or depicted on shields, targets, banners, or other martial instruments. They are also called *coats-of-arms*, from the custom of the ancients embroidering them on the coats they wore over their arms, as heralds do to this day.

Arms are distinguished by different names, to denote the causes of their bearing; such as,

A R M S

Of Dominion, Of Pretension, Of Concession, Of Communion,		Of Patronage, Of Family, Of Alliance, Of Succession.
---	--	---

Arms of *dominion* or sovereignty are those which emperors, kings, and sovereign states, do constantly bear; being, as it were, annexed to the territories, kingdoms, and

In hereditary and provinces, they possess. Thus the three lions are the arms of England, the fleurs-de-lis those of France, &c.

Arms of *pretension*, are those of such kingdoms, provinces, or territories, to which a prince or lord has some claim, and which he adds to his own, although the said kingdoms or territories be possessed by a foreign prince or other lord. Thus the kings of England have quartered the arms of France with their own, ever since Edward III. laid claim to the kingdom of France, which happened in the year 1330, on account of his being son to Isabella, sister to Charles the Handsome, who died without issue.

Arms of *concession*, or augmentation of honour, are either entire arms, or else one or more figures, given by princes as a reward for some extraordinary service. We read in history, that Robert Bruce, king of Scotland, allowed the earl of Winton's ancestor to bear, in his coat-armour, a crown supported by a sword, to show that he, and the clan Seaton, of which he was the head, supported his tottering crown. Queen Anne granted to Sir Cloudesly Shovel, rear-admiral of Great Britain, a cheveron between two fleurs-de-lis in chief, and a crescent in base, to denote three great victories he had gained; two over the French, and one over the Turka.

Arms of *community*, are those of bishoprics, cities, universities, academies, societies, companies, and other bodies corporate.

Arms of *patronage*, are such as governors of provinces, lords of manors, patrons of benefices, &c. add to their family-arms, as a token of their superiority, rights, and jurisdiction. These arms have introduced into heraldry, castles, gates, wheels, ploughs, rakes, harrows, &c.

Arms of *family*, or *paternal arms*, are those that belong to one particular family, that distinguish it from others, and which no person is suffered to assume without committing a crime, which sovereigns have a right to restrain and punish.

Arms of *alliance*, are those which families or private persons take up and join to their own, to denote the alliances they have contracted by marriage. This sort of arms is either impaled, or borne in an *escutcheon of pretence*, by those who have married heiresses.

Arms of *succession*, are such as are taken up by them who inherit certain estates, manors, &c. either by will, entail, or donation, and which they either impale or quarter with their own arms; which multiplies the titles of some families out of necessity, and not through ostentation, as many imagine.

These are the eight classes under which the divers sorts of arms are generally ranged; but there is a sort which blazoners call *assumptive arms*, being such as are taken up by the caprice or fancy of upstarts, though of ever so mean extraction, who, being advanced to a degree of fortune, assume them without a legal title. This, indeed, is a great abuse of heraldry; and common only in Britain, for on the continent no such practice takes place.

We now proceed to consider the essential and integral parts of arms, which are these:

The ESCUTCHEON, The CHARGES,
The TINCTURES, The ORNAMENTS.

CHAP. I. *Of the Shield or Escutcheon.*

Of the Shield, &c.

THE *shield* or *escutcheon* is the field or ground whereon are represented the figures that make up a coat of arms: for these marks of distinction were put on bucklers or shields before they were placed on banners, standards, flags, and coat-armour; and wherever they may be fixed, they are still on a plane or superficies whose form resembles a shield.

Shields, in *Heraldry* called *escutcheons* or *scutcheons*, from the Latin word *scutum*, have been, and still are, of different forms according to different times and nations. Among ancient shields, some were almost like a horse-shoe, such as is represented by n° 1. in the figure of Escutcheons; others triangular, somewhat rounded at the bottom, as n° 2. The people who inhabited Mesopotamia, now called *Diarbeck*, made use of this sort of shield, which it is thought they had of the Trojans. Sometimes the shield was heptagonal, that is, had seven sides, as n° 3. The first of this shape is said to have been used by the famous triumvir M. Antony. That of knights-banneret was square, like a banner, as n° 4. As to modern escutcheons, those of the Italians, particularly of ecclesiastics, are generally oval, as n° 5. The English, French, Germans, and other nations, have their escutcheons formed different ways, according to the carver's or painter's fancy; see the various examples, contained from n° 6—16 of the figure. But the escutcheon of maids, widows, and of such as are born ladies, and are married to private gentlemen, is of the form of a lozenge: See n° 17—20. Sir George Mackenzie mentions one Muriel, countess of Strathern, who carried her arms in a lozenge, anno 1284, which shows how long we have been versant in heraldry.

Plata CCLIV.

Armorists distinguish several parts or points in escutcheons; in order to determine exactly the position of the bearings they are charged with; they are here denoted by the first nine letters of the alphabet, ranged in the following manner:

- A—the dexter chief.
- B—the precise middle chief.
- C—the sinister chief.
- D—the honour point.
- E—the fess point.
- F—the nombril point.
- G—the dexter base.
- H—the middle precise base.
- I—the sinister base.



The knowledge of these points is of great importance, and ought to be well observed, for they are frequently occupied with several things of different kinds. It is necessary to observe, that the dexter side of the escutcheon is opposite to the left hand, and the sinister side to the right hand of the person that looks on it.

CHAP. II. *Of Tinctures, Furs, Lines, and Differences.*

SECT. I. *Of Tinctures.*

BY *tinctures* is meant that variable hue of arms which is common both to shields and their bearings.

According

The Tinctures seven tinctures in armoury; of which two are metals, the other five are colours.

The Metals are,
Gold, } termed } *Or.*
Silver, } *Argent.*

The Colours are,
Blue, } termed } *Azure.*
Red, } *Gules.*
Green, } *Vert.*
Purple, } *Purpure.*
Black, } *Sable.*

When natural bodies, such as animals, plants, celestial bodies, &c. are introduced into coats of arms, they naturally retain their natural colours, which is expressed in this science by the word *proper*.

Besides the five colours above mentioned, the English writers on Heraldry admit two others, *viz.*

Orange, } termed } *Tenny.*
Blood-colour, } *Sanguine.*

But these two are rarely to be found in British bearings.

These tinctures are represented in engravings and drawings (the invention of the ingenious Silvester Petra Sancta, an Italian author of the 17th century) by dots and lines, as in fig. ii. n^o 1—9.

Or is expressed by dots.

Argent needs no mark, and is therefore plain.

Azure, by horizontal lines.

Gules, by perpendicular lines.

Vert, by diagonal lines from the dexter chief to the sinister base points.

Purpure, by diagonal lines from the sinister chief to the dexter base points.

Sable, by perpendicular and horizontal lines crossing each other.

Tenny, by diagonal lines from the sinister chief to the dexter base points, traversed by horizontal lines.

Sanguine, by lines crossing each other diagonally from dexter to sinister, and from sinister to dexter.

Sir George M'Kenzie observes, that "some fantastic heralds have blazoned not only by the ordinary colours and metals, but by flowers, days of the week, parts of a man's body, &c. and have been condemned for it by the heralds of all nations. Yet the English have so far owned this fancy," (the most judicious of them, as Mr Cartwright and others reprobate it as absurd), "that they give it for a rule that the coats of sovereigns should be blazoned by the planets, those of noblemen by precious stones; and have suited them in the manner here set down.

Or	Topaz	Sol.
Argent	Pearl	Luna.
Sable	Diamond	Saturn.
Gules	Ruby	Mars.
Azure	Sapphire	Jupiter.
Vert	Emerald	Venus.
Purpure	Amethyst	Mercury.
Tenny	Jacinth	Dragon's-head.
Sanguine	Sardonix	Dragon's tail.

"But I crave leave to say, that these are but mere fancies; and are likewise unfit for the art, for these reasons: 1st, The French (from whom the English derive their heraldry, not only in principles, but in words of the French language) do not only not use these different ways of blazoning, but treat them *ex ridicule*. 2dly, The Italian, Spanish, and Latin heralds use no such different forms, but blazon by the ordinary metals and colours. 3dly, Art should imitate nature; and as it would be an unnatural thing in common discourse not to call red *red* because a prince wears it, so it is unnatural to use these terms in heraldry. And it may fall out to be very ridiculous in some arms: for instance, if a prince had for his arms an *ass couchant* under his burden *gules*, how ridiculous would it be to say he had an *ass couchant Mars*?—A hundred other examples might be given; but it is enough to say, that this is to confound colours with charges, and the things that are borne with colour. 4thly, It makes the art unpleasant, and deters gentlemen from studying it, and strangers from understanding what our heraldry is; nor could the arms of our princes and nobility be translated in this disguise into Latin or any other language. But that which convinces most that this is an error is, because it makes that great rule unnecessary, whereby colour cannot be put upon colour, nor metal upon metal; but this cannot hold but where metals and colours are expressed."

The English heralds give different names to the roundlet (N^o 10), according to its colour. Thus, if it is

Or,	} it is called a {	<i>Besant.</i>
Argent,		<i>Plute.</i>
Azure,		<i>Hurt.</i>
Gules,		<i>Tortreau.</i>
Vert,		<i>Pompey.</i>
Purpure,		<i>Golpe.</i>
Sable,		<i>Pellet.</i>
Tenny,		<i>Orange.</i>
Sanguine,		<i>Guse.</i>

The French, and all other nations, do not admit such a multiplicity of names to this figure; but call them *Besants*, after an ancient coin struck at Constantinople, once *Byzantium*, if they are Or and Tortreaux; or of any other tincture, expressing the same.

SECT. II. Of Furs.

FURS represent the hairy skin of certain beasts, prepared for the doublings or linings of robes and garments of state: and as shields were anciently covered with furred skins, they are therefore used in heraldry not only for the linings of the mantles, and other ornaments of the shields, but also in the coats of arms themselves.

There are three different kinds in general use, *viz.*

1. *Ermine*; which is a field argent, powdered with black spots, their tails terminating in three hairs. (Fig. ii. N^o 11.).

2. *Counter-ermine*, where the field is sable, and the powdering white. (N^o 12.).

3. *Vair*, (N^o 15.), which is expressed by blue and white skins, cut into the forms of little bells, ranged in rows opposite to each other, the base of the white

Lines. ones being always next to that of the blue ones. Vair is usually of six rows; if there be more or fewer, the number ought to be expressed; and if the colours are different from those above mentioned, they must likewise be expressed.

The English multiply the furs, as well as the names of the tinctures, though no other nation has adopted such varieties. Thus they give us,

1. *White*, which is the natural colour of the ermine; but it is used on no other occasion but in the descriptions of mantles.

2. *Ermines*, which is the same with contra-ermine.

3. *Erminois*; the field is Or, the powdering Sable, (N^o 13.). For the use of this fur Guillim cites Bara, p. 14.; but no such fur is to be found in Bara.

4. *Pean*; the field is Sable, the powdering Or, (N^o 14.). The French use no such term: but they call all furs or doublings *des pannes* or *pennes*; which term has possibly given rise to this mistake, and many others, in those who do not understand the French language.

5. *Erminites*; the same as Ermine, with the addition of a red hair on each side of the black. Sir George M^cKenzie calls these distinctions "but fancies, for *erminites* signifies properly *little ermines*."

6. *Counter-vair*; when the bells of the same tincture are placed base against base, and point against point, (N^o 16.).

7. *Potent-counter-potent*, anciently called *Vairy-cuppy*, as when the field is filled with crutches or potents counter-placed, (N^o 17.).

It may not be improper to observe, that the use of the tinctures took its rise from the several colours used by warriors whilst they were in the army, which S. de Petra Sancta proves by many citations. And because it was the custom to embroider gold and silver on silk, or silk on cloth of gold and silver, the heralds did therefore appoint, that in imitation of the clothes so embroidered, colour should never be used upon colour, nor metal upon metal.

SECT. III. *Of the Lines used in the parting of Fields.*

ESCUTCHEONS are either of one tincture, or more than one. Those that are of one only, that is, when some metal, colour, or fur, is spread all over the surface or field, such a tincture is said to be predominant: but in such as have on them more than one, as most have, the field is divided by lines; which, according to their divers forms, receive various names.

Lines may be either straight or crooked. Straight lines are carried evenly through the escutcheon: and are of four different kinds; viz. a perpendicular line |; a horizontal, —; a diagonal dexter, \; a diagonal sinister, /.

Crooked lines are those which are carried unevenly through the escutcheon with rising and falling. French armorists reckon 11 different sorts of them; Guillim

admits of 7 only; but there are 14 distinct kinds, Of Lines. N^o 1—14. viz.

1. The engrailed.
2. The invected.
3. The wavy.
4. The embattled, or crenelle.
5. The nebule.
6. The raguly.
7. The indented.
8. The dancette.
9. The dove-tail.
10. The grafted.
11. The embattled aronde.
12. The battled embattled.
13. The pattes or dovetail.
14. Champaine.

The principal reason why lines are thus used in heraldry, is to difference bearings which would be otherwise the same; for an escutcheon charged with a chief engrailed, differs from one charged with a chief wavy, as much as if the one bore a cross and the other a saltier.

As the fore-mentioned lines serve to divide the field, it must be observed, that if the division consists of two equal parts made by the perpendicular line, it is called *parted per pale*; by the horizontal line, *parted per fess*; by the diagonal dexter, *parted per bend*; by the diagonal sinister, *parted per bend sinister*; examples of which will be given in the sequel of this treatise.

If a field is divided into four equal parts by any of these lines, it is said to be *quartered*; which may be done two ways, viz.

Quartered or *parted per cross*; which is made by a perpendicular and horizontal line, which, crossing each other at the centre of the field, divide it into four equal parts called *quarters*. See Plate CCLIV. under fig. 1. (A).

Quartered or *parted per saltier*; which is made by two diagonal lines, dexter and sinister, that cross one another in the centre of the field, and likewise divide it into four equal parts. *Ibid.*

The escutcheon is sometimes divided into a greater number of parts, in order to place in it the arms of the several families to which one is allied; and in this case it is called a *genealogical achievement*. These divisions may consist of 6, 8, 12, and 16, quarters [as under fig. 1. (A)], and even sometimes of 20, 32, 64, and upwards; there being examples of such divisions frequently exhibited at pompous funerals. An extraordinary instance of this kind was exhibited at the pompous funeral of the Viscountess Townshend, whose corpse was brought from Dublin castle in Ireland to Rainham-hall in Norfolk, one of the principal tenants on horseback carrying before the hearse a genealogical banner, containing the quarterings of his lordship's and her ladyship's family, to the amount of upwards of 160 coats. Sir George Booth, rector of the valuable living of Ashton under Line, bears six distinct coats of arms in his shield; viz. those for Booth, Barton, Venables, Mountfort, Ashton, Egerton; and has besides a right to 37 other coats: but Sir William Dugdale very justly objects to so many arms being clustered together in one shield or banner, on account of the difficulty of knowing and distinguishing one coat of arms from another.

SECT.

(A) Bordures are still introduced into English coats of arms, but for particular reasons, which heralds can best explain. They are by the French frequently taken for a principal figure, and numbered among the rest of the ordinaries.

SECT. IV. *Of the Differences of Coats of Arms.*

ARMORISTS have invented divers differences or characteristic marks, whereby bearers of the same coat of arms are distinguished each from others, and their nearness to the principal bearer demonstrated. According to J. Guillim, these differences are to be considered either as ancient or modern.

ART. I. OF ANCIENT DIFFERENCES.

Those he calls *ancient differences* consist in *bordures* (A); which is a bearing that goes all round, and parallel to the boundary of the escutcheon, in form of a hem, and always contains a fifth part of the field in breadth. *Bordures* were used in ancient times for the distinguishing not only of one nation or tribe from another, but also to note a diversity between particular persons descended of one family and from the same parents. This distinction, however, was not expressly signified by invariable marks; nor were *bordures* always appropriated to denote the different degrees of consanguinity; for, as Sir Henry Spelman observes in his *Aspilogia*, p. 140. ancient heralds, being fond of perspicuous differences, often inverted the paternal tincture, or sometimes inserted another charge in the escutcheon, such as bends, crozlets, cantons, or the like; which irregularity has, I suppose, induced modern armorists to invent and make use of others."

Plate
CCLV.

There are *bordures* of different forms and tinctures, as in the examples, fig. 3.

N^o 1. is "Sable, a *Bordure* Argent;" borne by the right hon. Sackville Tufton, earl of Thanet.—When a *bordure* is plain, you are not to mention it, as it is always understood so in heraldry, though it be not expressed; but if it has any other form, you are to signify it.

2. "Gules, a *Bordure* engrailed Argent;" borne by the right hon. Charles Gray, Lord Gray.—This is called *engrailed*, from the French word *engrêlé*, which signifies a thing the hail has fallen upon and broken off the edges, leaving it with little semicircles struck out of it.

3. "Gules, a *Bordure* engrailed Or:" borne by the right hon. George Talbot, earl of Shrewsbury. You must observe, that in a *bordure* or ordinary formed of these lines, the points are represented on all sides towards the field, and the semicircles turned towards the *bordure* or ordinary.

4. "Argent, a *Bordure* inverted Azure."—This is quite contrary to the last; for as the other turns its points from the *bordure* into the field, so contrariwise this does, by the inversion of the points from the field into the *bordure*. Such a charge or any other formed of these lines is seldom to be met with in English coats of arms.

5. "Gules, a *Bordure* indented Argent."—This word *indented* requires very little explanation, the signification being obvious to all persons, from its figure, which is composed of tracks resembling teeth, called in Latin *dentes*.

6. "Azure, a *Bordure* Ermine."

7. "Vert, a *Bordure* Vair."

8. "Ermine, a *Bordure* composit, or gobony, Or

and Sable."—This is so termed from its being composed of small equal pieces. J. Guillim calls this *bordure gobonated*, which implies the same meaning; but the word being obsolete, is not used by modern heralds.

9. "Quarterly, Azure and Gules, a *bordure* composit Argent and Azure;" borne by his grace Henry Somerset, duke of Beaufort, &c.

10. "Azure, a *Bordure* counter-composit Argent and Gules."—Observe, that the counter-composit does always consist of two tracks and no more.

11. "Or, a *Bordure* chequy Argent and Sable."—This has a great resemblance with the last *bordure*, having only one track more; therefore you must take care, before you blazon, to number them, or else you may easily err in taking the one for the other.

12. "Gules, a *Bordure* Argent, charged with eight Trefoils slipped proper, that is, Vert."—All nations use few terms in blazoning *bordures*; but English armorists, in order possibly to raise the dignity of this science, have perplexed it, and rendered it unintelligible to all foreigners, by introducing into it several mystical proper names, among which may be reckoned the following ones, viz. They call a *bordure*, if charged with eight plants, fruits, flowers, or leaves, *verdoy* of such vegetables; or *enluron* of such birds; *enrury* of beasts; *perflew* of furs; and *entoyre* of inanimate things of what kind soever.

13. "Gules on a *Bordure* Azure, eight Stars Or."

14. "Argent, a *Bordure* composit of the last and Gules, the first charged with Roses of the second, barbed and seeded proper." This *bordure* is borne by his grace Charles Lenox duke of Richmond, &c.

15. "Ermine, with a *Bordure* engrailed Gules;" the coat of arms of the right hon. Henry-Benedict Barnewall, Viscount Kingsland, &c. of Ireland.—This ancient and noble family is of French extraction, and allied to the dukes of Little-Bretagne, where the name continues still in great repute.

16. "Argent, a *Bordure* Sable charged with eight Besants;" borne by the right hon. ——— Cole, Lord Ranelagh, of Ireland.

17. "Party per pale Argent and Gules, a *Bordure* charged with eight Escallops counterchanged;" the coat of arms of the right hon. William Maule, earl of Panmure, &c. of Ireland. This very ancient family is originally French, and derives its surname from the town and lordship of Maule in Normandy, where the same arms are still to be seen in the parish-church.

17. "Azure, a *Bordure* quarterly, the first and fourth Ermine, the second and third counter-composit Argent and Azure."

19. "Purple, a *Bordure* composit Or and Gules, each of the last charged with a Besant."

20. "Quarterly Or and Gules, within a *Bordure* Vert, charged with eight Escallops Or."

We shall conclude this head with observing, that a *bordure* is never of metal upon metal, and seldom of colour upon colour, but rather of the tincture which the principal bearing or charge is of. Thus Sir — Dalziel of Glenae, whose predecessor was a younger brother of the noble family of Carnwath, has, within a *Bordure* Argent, the paternal coat of the ancient name of Dalziel, viz. "Sable, a hanged man with his arms extended, Argent;" formerly they carried him

Ancient
Differences.

Modern Differences.

hanging on a gallows. This bearing, though so very singular for a coat of arms, was given as a reward to one of the ancestors of the late Robert Dalziel, earl of Carnwath, to perpetuate the memory of a brave and hazardous exploit performed, in taking down from a gallows the body of a favourite and near relation of King Kenneth II. hung up by the Picts; which story is thus related by Alexander Nisbet: "The king being exceedingly grieved that the body of his minion and kinsman should be so disgracefully treated, he proffered a great reward to any of his subjects who would adventure to rescue his corpse from the disgrace his cruel enemies had unjustly put upon it: but when none would undertake this hazardous enterprise, at last a valorous gentleman came and said to the king, *Dalziel*, which signifies, "I dare;" and he did actually perform that noble exploit to the king's satisfaction and his own immortal honour, and in memory of it got the aforesaid remarkable bearing: and afterwards his posterity took the word *Dalziel* for their surname, and the interpretation of it, *I dare*, continues even to this day to be the motto of that noble family." We can have no better proof of the truth of this tradition than this, that the heads of this ancient family have for many ages carefully retained this bearing without any alteration or addition.

ART. 2. OF MODERN DIFFERENCES.

The modern differences which the English have adopted not only for the distinguishing of sons issued out of one family, but also to denote the difference and subordinate degrees in each house from the original ancestors, are nine, viz.

For the heir or first son, the Label; 2d son, the Crescent; 3d son, the Mullet; 4th son, the Martlet; 5th son, the Annulet; 6th son, the Flower-de-luce; 7th son, the Rose; 8th son, the Cross moline; 9th son, the Double Quarter-foil.

By these differences, the six sons of Thomas Beauchamp, the 15th earl of Warwick, who died in the 34th year of King Edward III. are distinguished in an old window of the church of St Mary at Warwick; so that although they are called *modern differences*, their usage with the English is ancient.

It must be observed, that, of all the fore-mentioned marks of distinction, none but the label is affixed on the coats of arms belonging to any of the royal family; which the introducers of this peculiarity have, however, thought proper to distinguish by additional pendants and distinct charges on them.

As to the distinction to be made in the arms of the offspring belonging to each of the above-mentioned brothers, it is expressed by figures on the top and margin of the table contained in fig. 4. For instance, The heir or first son of the second house, beareth a crescent charged with a label during his father's life only. The second son of the second house, a crescent charged with another crescent. The third son of the second house, a crescent charged with a mullet. The fourth son of the second house, a crescent charged with a martlet. The fifth son of the second house, a crescent charged with an annulet. The sixth son of the second house, a crescent charged with a flower-de-luce; and so on of the other sons, taking care to have them of a different tincture.

Modern Differences.

In what part of the escutcheon these differences should be borne is not certain; for Guillim, Morgan, and others, give us many different examples of their position. The honour-point would be the properest place, if the arms would admit of it; but that is not always the case, as that part may be charged with some figure in the paternal coat, which cannot with propriety receive the difference. There are instances where these are borne as perfect coats of arms, as the examples subjoined to the Table of Houses sufficiently show; which are to be blazoned thus:

The first is "Azure, a Label Argent."—When such a label is borne as a difference, the pendants, according to G. Leigh, signify that he is but the third person; the dexter pendant referring to his father, the sinister to his mother, and the middle one to himself.

The second is "Argent, a Label of five points Azure;" borne by the name of Hentington. If a label has more or less than three pendants or points, they are to be expressed as in the foregoing example.

The third is "Azure, a Crescent Argent," borne by the name of Lucy.—The reason G. Leigh assigns for the second son's having a crescent for a difference is to show that he should increase the family by adding to it riches and reputation.

The fourth is "Argent, a Mullet Sable, on a Chief Azure, a Fleur-de-lis Or;" borne by the name of Rogers, in Gloucestershire.—A mullet or spur was appointed for the third son's difference, as the last mentioned author says, to show that he should follow chivalry.

The fifth is "Azure, a Fleur-de-lis Argent;" borne by the right hon. Henry Digby, Baron Digby of Geashil, in King's county, Ireland.

These few examples, among many more that might be given, demonstrate the impropriety of adopting these *modern differences*, as they are called, for marks of cadency to distinguish the different branches of a family; for it is impossible to distinguish the uncle or grand-uncle, from the nephew, or grand-nephew, if each of them are second, third or fourth sons; and in the course of succession these differences would multiply to such a number, that it would be impossible to delineate them distinctly in most cases. But as they are given by most of the English writers on heraldry, though no foreign nation uses them, it was thought proper to insert them here.

Sisters, except of the blood-royal, have no other mark of difference in their coats of arms, but the form of the escutcheon (as observed before); therefore they are permitted to bear the arms of their father, even as the eldest son does after his father's decease. The reason of which is by Guillim said to be, that when they are married, they lose their surname, and receive that of their husbands.

Next to these diminutions, G. Leigh, J. Guillim, and after them Dr Harris in his *Lexicon Technicum*, set forth at large divers figures, which they pretend were formerly added to the coats of such as were to be punished and branded for cowardice, fornication, slander, adultery, treason, or murder, for which they give them the name of *abatements of honour*; but as they produce but one instance of such whimsical bearings, we have not inserted them here. Besides, arms

Plate CCLIV. under fig. 1. A).

Plate CCLV.

Honourable Ordinaries.

being marks of honour, they cannot admit of any note of infamy; nor would any body now-a-days bear them if they were so branded. It is true, a man may be degraded for divers crimes, particularly high treason; but in such cases the escutcheon is reversed, trod upon, and torn in pieces, to denote a total extinction and suppression of the honour and dignity of the person to whom it belonged.

CHAP. III. *Of the Charges.*

ARMORISTS call a charge whatsoever is contained in the field, whether it occupy the whole or only a part thereof. All charges are distinguished by the names of *honourable ordinaries, sub-ordinaries, and common charges.*

Honourable ordinaries, the principal charges in heraldry, are made of lines only, which, according to their disposition and form, receive different names.

Sub-ordinaries are ancient heraldic figures, frequently used in coats of arms, and which are distinguished by terms appropriated to each of them.

Common charges are composed of natural, artificial, and even chimerical things; such as planets, creatures, vegetables, instruments, &c.

SECT. I. *Of Honourable Ordinaries.*

THE most judicious armorists admit only of nine honourable ordinaries, viz.

The Chief		The Bar
The Pale		The Chevron
The Bend		The Cross
The Bend sinister		and
The Fess		The Saltier.

Of these, but six have diminutives, which are called as follows: That of the chief is a *fillet*; the pale has a *pallet* and *endorse*; the bend, a *bendlet, cost, and ribband*; the bend sinister has the *scarp* and *baton*; the bar, the *closet* and *barulet*; the chevron, a *chevronel* and *compleclose*. All which will be treated of in their order.

ART. I. *Of the CHIEF.*

The chief is an ordinary determined by an horizontal line, which, if it is of any other form but straight, must be expressed. It is placed in the upper part of the escutcheon, and containeth in depth the third part of the field. Its diminutive is a fillet, the content of which is not to exceed one-fourth of the chief, and standeth in the lowest part thereof. This ordinary is subject to be charged with variety of figures; and may be indented, wavy, nebule, &c. as in the examples, fig. 5.

Plate COLV.

N^o 1. is "Or, a Chief indented Azure;" borne by the right hon. Edmund Butler, Viscount Mountgarret, &c. of the kingdom of Ireland. This great and illustrious family of the Butlers, so renowned for the many valiant and loyal persons it has produced, is descended from the ancient counts of Brion in Normandy; but since King Henry II. conferred the office of chief butler of Ireland upon one of the family, he and his successors have assumed the name of *Butler*.

- 2. "Azure, a Chief engrailed Or."
- 3. "Argent, a Chief invected Vert."

Of the Chief.

- 4. "Vert, a Chief undy Or."
- 5. "Azure, a Chief nebule Argent."
- 6. "Or, a Chief checky Azure and Argent."
- 7. "Ermine, a Chief quarterly Or and Gules;" borne by the name of Peckham.
- 8. "Argent, a Chief Sable, in the lower part thereof a Fillet of the Field."
- 9. "Azure, fretty Argent, a Chief Or;" borne by the right hon. Hayes St Leger, Viscount Doneraile, &c. of the county of Cork in Ireland. This ancient and noble family is of French extraction; and is descended from Sir Robert Sent Legere, knight, who, in 1066, accompanied William duke of Normandy in his expedition into England; and the family have a tradition, that he, with his own hand, supported the said duke when he quitted the ship to land in Sussex.
- 10. "Argent, on a Chief engrailed Azure, a Tortoise passant Or;" borne by the name of *Bidgood*.
- 11. "Argent, on a Chief Gules, two Spur revels Or;" borne by the right hon. John St John, Lord St John of Bletshoe, &c. Of this ancient family, which derive their surname from a place called *St John*, in Normandy, was John de St John, Esq. who having a principal employment in the army of the Norman duke, attended him in his expedition into England.
- 12. "Argent, on a Chief Vert, two Spears Heads erect of the Field, the points imbrued Gules;" borne by the right hon. George Brodrick, Viscount Middleton, &c. of the kingdom of Ireland. This family is lineally descended from George de Brodrick, who came into England in the reign of William II.
- 13. "Or, on a Chief Sable, three Escallops of the field," for the name of *Graham*; and borne quartered in the arms of his Grace William Graham, duke, marquis, and earl of Montrose, &c. with Argent three Roses Gules. According to the Scots writers this great and noble family is descended from the renowned Grème or Grame, who in the year 404 was general of King Fergus II.'s army, and in 420 forced his way through the wall built by the Romans between the rivers Forth and Clyde to keep out the Scots from molesting them in their possessions, and the said breach has ever since been called *Grème's Dike*.
- 14. "Argent, on a chief indented Gules, three Crosses pattee of the Field;" borne by the right hon. John Percival earl of Egmont, &c. This very ancient and noble family is supposed, from circumstances little short of positive proof, to have sprung from a younger branch of the sovereign dukes of Bretagne in France, of the same name. They were transplanted into Normandy before the Conquest, possessed of great estates and power, and invested with the office of chief butler. Upon the Norman invasion, two of this family came over into England with the Conqueror, from one of which the descent of the present earl of Egmont is deduced by the clearest and most indisputable proofs of historians and records.
- 15. "Azure, on a Chief indented Or, three Spur-revels Gules;" borne by the right hon. Charles Moore, earl of Drogheda, &c. of the kingdom of Ireland. This noble family, which is of French extraction, came into England soon after the Conquest, and made their

Of the Pale. first residence in the manor of Moore-court, in the county of Kent.

16. "Ermine, on a Chief indented Azure, three ducal coronets Or;" borne by the name of *Lytton*.

17. "Azure, on a Chief Or, three Martlets Gules," for the name of *Wray*; and borne by Sir Cecil Wray, Bart. of Lincolnshire.

18. "Ermine, on a Chief Gules; five Lozenges of the first;" borne by the name of *Disin*.

19. "Argent, fretty Gules, on a Chief of the second, three Leopards Faces Or;" borne by the right hon. Henry Liddel, Lord Ravensworth. This noble lord is descended from the ancient lords of Liddle-castle, in the county of Durham, where they have been proprietors of great coal-mines time out of mind.

20. "Ermine, a Chief party per pale Azure and Or; on the dexter the Sun in his splendour, on the sinister a Cross pattee Gules." The arms of the bishopric of Raphoe, in the kingdom of Ireland.

ART. 2. Of the PALE.

The Pale is an ordinary, consisting of two perpendicular lines drawn from the top to the base of the escutcheon, and contains the third middle part of the field. Its diminutives are, the pallet, which is the half of the pale; and the endorse, which is the fourth part of a pale. This ordinary and the pallet may receive any charge, but the endorse should not be charged. The endorse, besides, is never used, according to J. Leigh, but to accompany the pale in pairs, as cotices do the bend; but Sir John Ferne is of a different opinion, fig. 6.

Ex. 1. "Gules, a Pale Or;" by the name of *Grandmain*.

2. "Party per Pale Argent and Gules, a Pale counterchanged."

3. "Argent, a Pale between two Endorses Gules."

4. "Party per Pale, 1st, Paly of six Argent and Sable, 2d, Azure;" borne by the name of *Trenchard*.

5. "Pale of six Or and Azure."

6. "Argent, three Pallets undy Sable;" by the name of *Downes*.

7. "Party per Pale, Argent and Gules;" borne by the right honourable John Waldegrave, Earl Waldegrave, &c. This noble earl is descended from John de Waldegrave, who was sheriff of London in the year 1205, in the seventh year of King John.

8. "Party per Pale indented, Or and Gules;" borne by the right honourable Thomas Bermingham, baron of Athenry, in the kingdom of Ireland. Of this ancient and noble family, which are of English extraction, and took their name from the town of Bermingham in the county of Warwick, was William de Bermingham, who was possessed of the town of that name in the reign of Henry II. which continued in that family till the reign of Henry VIII.

9. "Quarterly per Pale dove-tail, Gules and Or;" borne by the right honourable Thomas Bromley, Lord Montfort, &c. This noble lord is maternally descended from Sir Walter Bromleghe of Bromleghe, in the county of Stafford, who flourished in the reign of King John. Sir Thomas Bromley, another of his lordship's ancestors, was constituted lord high chancellor of England, 21 Elizabeth; in which post he died, 29 Elizabeth.

10. "Argent, a Pale flosy counterflosy Sable."

11. "Argent, a Pale lozengy Sable;" borne by the name of *Savage*.

12. "Argent, a Pale indented Vert;" borne by the name of *Dickson*.

13. "Argent, on a Pale engrailed Sable, three Crescents Or;" borne by the name of *Ashly*.

14. "Ermine on a Pale engrailed azure, three Lions Heads coupé Or;" borne by the name of *Avery*.

15. "Vert, on a Pale radiant Or, a Lion rampant Sable;" borne by the right honourable James O'Hara, Lord Tyrawley, &c. in the kingdom of Ireland. This noble lord is descended from Milesius king of Spain, by his eldest son Hiberius, who, with his brother Here-mon, established a colony in Ireland. Sir Charles O'Hara, father to the present lord, was created baron of Tyrawley by Queen Anne, Jan. 10. 1706, being at that time a lieutenant-general, and colonel of the royal regiment of fusiliers: and the next year was made general in Spain, where his son, Lord James, was wounded at the battle of Almanza.

16. "Azure, a Pallet Argent."

17. "Vert, an Endorse Or."

18. "Argent on two Pallets Sable, six Cross-crosets fitchy Or;" borne by the name of *Betunes*, of the county of Salop.

19. "Argent, two Endorses Gules, in Chief three Mulletts Sable;" borne by the name of *Vautort*.

20. "Azure, on a Pale walled with three pieces on each side Or, an Endorse Sable;" borne by the name of *Sublet de Noyers*, a family of distinction in France.

ART. 3. Of the BEND and BEND-SINISTER.

The bend is an ordinary formed by two diagonal lines, drawn from the dexter-chief to the sinister-base: and contains the fifth part of the field in breadth, if uncharged; but if charged, then the third. Its diminutives are, the bendlet, which is the half of a bend; the cost or cotice, when two of them accompany a bend, which is the fourth part of a bend; and the ribband, the moiety of a cost, or the eighth part of the field.

There is also the bend-sinister, which is of the same breadth as the bend, but drawn the contrary way: this is subdivided into a scrape, which is the half of the bend, and into a baton, which is the fourth part of the bend, but does not extend itself to the extremities of the field, there being part of it seen at both ends. See the examples, fig. 7.

Ex. 1. "Argent, a Bend wavy Sable;" borne by the right honourable John Wallop, earl of Portsmouth, &c. This noble earl is descended from the Wallops of Hampshire, a Saxon family, who were possessed of lands to a considerable value in the county at the time of the Conquest.

2. "Checky Or, and Azure, a Bend Ermine;" borne by the right honourable John Ward, Viscount Dudley and Ward, &c. The ancestors of this noble lord were anciently of the county of Norfolk, of which was Simon Ward, who had large possessions in the reign of Edward I. and was in France and Scotland in the reigns of King Edward II. and III.

3. "Azure, a Bend engrailed Argent, between two Cotices Or;" borne by the right honourable Matthew Fortescue, Lord Fortescue, as also by the

Of the Bend.

Plate CCLVI.

Plate CCLV.

Of the
Bend.

right honourable Hugh Fortescue-Aland, Baron Fortescue, in the kingdom of Ireland, this last nobleman bearing a crescent in his arms for difference. The family of Fortescue is descended from Sir Richard le Forte, a person of extraordinary strength and courage, who accompanied William duke of Normandy in his invasion of England; and bearing a strong shield before the duke, at the battle of Hastings, had three horses killed under him, and from that signal event the name and motto of the family were assumed; for the Latin word, *scutum*, or the old French word *escue* "a shield," being added to *forte*, "strong," compose their name; and the motto is, *Forte scutum salus ducum*.

4. "Sable, a Bend Argent between two Cotices indented Or;" borne by the name of *French*.

5. "Paly of six Or and Sable, a Bend counter-changed;" borne by the right honourable Frederick Calvert, Baron Baltimore. The original of this family is from an ancient and noble house of that surname in the earldom of Flanders, whereof Sir George Calvert, knight, among other honourable employments, was secretary of state to King James I. by whom he was created a baron, Feb. 20. 1624, and from whom he had a grant to him, and his heirs, of the province of Maryland and Avalon in America.

6. "Party per Bend crenelle Argent and Gules;" borne by the right honourable Edmund Boyle, earl of Cork and Orrery, &c. in the kingdom of Ireland. This noble lord is said to be descended from Sir Philip Boyle, a knight of Arragon, who, in the reign of King Henry VI. tilted at a tournament with Sir Joseph Astley, knight of the Garter.

7. "Argent, three Bendlets enhanced Gules;" as the English express it, but the phrase enhanced is used by no other nation. The proper blazon of this arms is, Parted per bend, 1st bendy of six gules, and argent; 2d of the last. Borne by the right honourable William Byron, Lord Byron. From Doomsday-book it appears, that this family was possessed of numerous manors and lands in the reign of the Conqueror; and that Sir John Byron, one of his lordship's ancestors, attended King Edward III. in his wars in France.

8. "Ermine, a Bend voided Gules;" borne by the name of *Ireton*.

9. "Argent three Bendlets wavy Azure;" borne by the name of *Wilbraham*.

10. "Bendy of six pieces Argent and Azure." Observe, that when the shield is filled with an equal number of bendlets of metal and colour, it is called *bendy*; but if the number of them is unequal, they are to be blazoned by the name *bendlets*, and their number specified.

11. "Party per bend Azure and Argent, two Bendlets engrailed counterchanged;" borne by the name of *Frenes*.

12. "Quarterly, Or and Gules, a Bend over-all Vair;" borne by his grace Lionel Cranfield Sackville, duke of Dorset and earl of Middlesex, &c. The ancestors of this family were lords of the town and seignory of Sackville in Normandy, and came over with the Conqueror when he invaded England in 1066.

13. "Gules on a Bend Argent, three Trefoils slipped proper;" borne by the right honourable George William Hervey, earl of Bristol, &c. This noble lord

derives his pedigree from Robert Fitz-Hervey, a younger son of Hervey duke of Orleans, who came over from France with William the Conqueror.

14. "Argent, on a bend Gules cotised Sable; three pairs of Wings conjoined of the first;" borne by the right honourable Richard Wingfield, Viscount Powerscourt, in the kingdom of Ireland. This noble lord is denominated from the manor of Wingfield in Suffolk, where they had a seat before the Norman conquest, called *Wingfield-castle*.

15. "Gules, on a Bend contre Ermine cotised Or, three Boars heads couped Argent;" borne by the right honourable George Edgcumbe, Lord Edgcumbe, &c. The ancestors of this noble lord received their name from the manor of Edgcumbe, in Devonshire. One of this lord's ancestors was Sir Richard Edgcumbe, who came over to England with the earl of Richmond, having a great share in the victory he obtained over King Richard III. at Bosworth, by which the earl made his way to the throne of England.

16. "Argent, a Bend-sinister Gules."

17. "Or, a Bendlet Gules."

18. "Argent, a Ribband Gules."—The name of this bearing corresponds well with its form, being both long and narrow, which is the shape of a ribband.

19. "Azure, a Scrape Or."—This bearing, as Guillim observes, is that kind of ornament called now-a-days a *Scarf*, which is used by officers on duty, and usually worn after the same manner.

20. This contains three Batons. The first is compony ermine and azure; set over the royal arms, for his grace William Fitzroy duke of Cleveland. The second is compony argent and azure; set over the royal arms, for his grace Augustus Henry Fitzroy, duke of Grafton. The third is gules, charged with three roses argent, seeded and barbed proper; set over the royal arms, for his grace George Beauclerk, duke of St Albans. The grandfathers of these noble dukes being natural sons of King Charles II. is what entitles them to the royal arms.

ART. 4. Of the FESS and BAR.

The Fess is an ordinary which is produced by two parallel lines, drawn horizontally across the centre of the field, and contains in breadth the third part thereof. Some English writers say it has no diminutive. for a bar is a distinct ordinary of itself.

The Bar, according to their definition, is formed of two lines, and contains but the fifth part of the field: which is not the only thing wherein it differs from the fess; for there may be more than one in an escutcheon, placed in different parts thereof, whereas the fess is limited to the centre-point; but in this the French differ from them. The bar has two diminutives; the barulet, which contains the half of the bar; and the closet, which is the half of the barulet. When the shield contains a number of bars of metal and colour alternate, of even number, that is called *barry* of so many pieces, expressing their number. See the examples, fig. 8.

N^o 1. is "Argent, a Fess indented Sable;" borne by the right honourable John West, Earl Delaware, &c. This noble family is descended from the Wests, a great family in the west of England; but in the reign of Edward II. they appear to have been seised of manors

Plate
CCLVI.

of the Fess and Bar. and lands in the county of Warwick. Sir Thomas de West, knight, one of his lordship's ancestors, being at the battle of Cressy, and there taking John the French king prisoner, had granted him, for that remarkable action, an augmentation to his achievement, viz. a Crampette Or, distinguished by the chape of a sword in the middle; the chape being given him by the said king, as an acknowledgement of his becoming his prisoner: his cognizance was a rose parted per pale, argent, and gules; which two badges are still borne in the achievement of the present Lord De-laware.

2. "Argent, a Fess wreathed Azure and Gules;" borne by the right honourable John Carmichael, earl of Hyndford. Of this ancient family, which is said to assume their surname from the lands of Carmichael, in the county of Lanark, in Scotland, where they still have their chief seat, was Sir John Carmichael, who accompanied Archibald, earl of Douglas, to the assistance of Charles VI. of France, against the English; and signalizing his valour at the battle of Baughay in April 1421, and breaking his spear when the French and Scots got the victory, had thereupon added to his paternal coat, a dexter arm holding a broken spear, which is now the crest of the family.

2. "Party per Fess Or and Argent, a Fess nebule Gules;" borne by the name of *Anteshed*.

4. "Party per Fess indented Or and Azure;" borne by the name of *Saunders*.

5. "Checky Or and Azure on a Fess Gules, a Crescent Argent for difference;" borne by the right honourable Hugh Clifford, Lord Clifford, of Chudley. This noble lord is descended from Walter de Clifford, of Clifford castle, in the county of Hereford, who came over into England with the Conqueror; of which family was fair Rosamond, mistress to King Henry II.

6. "Argent, on a Fess Azure, three Lozenges Or;" borne by the right honourable Basil Fielding, earl of Denbigh and Desmond, &c. This noble earl is descended from the earls of Hapsburg, in Germany. Geoffroy earl of Hapsburg, being oppressed by Rodolph emperor of Germany, came over into England, and one of his sons served King Henry III. in his wars, whose ancestors laying claim to the territories of Lauffenburg and Rhin-Fielding, in Germany, he took the name of *Fielding*.

7. "Or, on a Fess Gules, three Fleurs-de-lis of the first;" borne by the name of *Lennard*. This is in the first and fourth quarters of the right honourable Thomas Barret Lennard Lord Dacre's arms.

8. "Ermine, on a Fess Gules, a Lion passant Or;" borne by the right honourable John Proby, Baron Carysfort, &c. in the kingdom of Ireland.

9. "Sable, a Fess Ermine, between three Crescents Or;" borne by the right honourable George William Coventry, earl of Coventry, &c. This noble earl is descended from John Coventry, a native of the city of Coventry, and afterwards mercer and lord mayor of London, in the reign of Henry V.: from whom descended Thomas Coventry, one of the justices of the court of common-pleas, in the reign of Queen Elizabeth; whose son Thomas was recorder of London, and afterwards lord keeper of the great seal in the reign of King Charles I.

10. "Sable, a Fess checky, Or and Azure, between

three Besants;" borne by the right honourable Ridge-way Pitt, earl and baron of Londonderry, &c. Of this noble family, which were anciently of Bandfort, in the county of Dorset, was Thomas Pitt, Esq. who, in the reign of Queen Anne, was made governor of Fort St George in the East Indies, where he resided many years, and purchased a diamond, which he sold to the king of France for 125,000l. sterling, weighing 136 carats, and commonly known at this day by the name of *Pitt's diamond*.

11. "Or, on a Fess Sable, between three Muscovy Ducks proper, a Rose of the Field;" borne by the right honourable John Bateman, Viscount Bateman, &c. Of this noble family, which was anciently seated at Halesbrook, near St Omers in Flanders, was Giles Bateman, Esq. whose son was a merchant of London, and was father to Sir James Bateman, knight, who in 1712, was chosen member of parliament for Ilchester in the county of Somerset, and re-chosen in 1713.

12. "Sable, on a fess Argent, between three Leopards passant guardant Or, three Escallops Gules;" borne by the right honourable Wills Hill, earl of Hillsborough, &c. Of this family, which, in the reign of Queen Elizabeth, were of note in the county of Down, was Sir Moses Hill, who, during O'Neile's rebellion, was one of those gentlemen who associated under the earl of Essex to suppress it; and afterwards served under Arthur Lord Chichester, lord deputy, and by King James I. was appointed provost-marshal of the whole province of Ulster in Ireland.

13. "Gules, two Bars Or;" borne by the right honourable Simon Harcourt, earl of Harcourt, &c. This noble earl is descended from the Harcourts of Normandy, who took their name from a place called *Harcourt*, in that province, where the family usually resided. Gervaise, count de Harcourt, with his two sons Jeffrey and Arnold, came over with the Conqueror, when he invaded England in 1066.

14. "Ermine, two Bars Gules;" borne by the right honourable Thomas Nugent, earl of Westmeath, Baron Delvin.

15. "Argent, two Bars indented Sable;" borne by the right honourable Godart Ginkle, earl of Athlone. Godart, who was the first earl, was descended of a very ancient family in the united provinces of Holland, where he was baron de Reede and Ginkle, &c. In 1691, he was a lieutenant-general of King William's forces in Ireland; where, in June the same year, he took Ballymore for the English; and, in July following the Irish town of Athlone, which last exploit is one of the greatest recorded in history.

16. "Argent, three Bars gemels Gules;" borne by the right honourable Richard Barry, earl of Barrymore, &c. This noble family, who have been renowned for their loyalty and valour, are said to derive their surname from the island of Barry, in the county of Glamorgan, in Wales; and from their riches and estates have been called by the people *Barrymore*, or the Great Barry.

17. "Or, a Fess-couped Gules, between two Lions passant Sable;" borne by the right honourable Samuel Masham, Lord Masham, &c. This noble lord is descended from Sir John Masham, who flourished in the reign of King Henry VI. and was buried at Thorneham, in the county of Suffolk, in 1455.

Of the
Cheveron.

18. "Argent, a Lion rampant guardant Gules, debruised by a Fess Azure, between three Etoiles issuing out of as many Crescents of the second;" borne by the right honourable Robert Dillon, earl of Roscommon, &c. in the kingdom of Ireland. This noble family is derived from Logan, surnamed *Dilune* or *Delion*, which signifies brave and valiant, to whom the duke of Aquitaine gave his daughter in marriage, in whose right, after her father's death, he became prince and sovereign of Aquitaine, which continued in his posterity till Henry II. married Alionora, daughter and heir to William V. duke of Aquitaine, and about 1172 obtained that principality by superior force; and, to prevent any disturbance, brought Sir Henry Delion or Dillon, and his brother Thomas, then infants, to England, their father being slain.

19. "Or, two Bars Azure, a Chief quarterly of the second and Gules, the 1st and 4th charged each with two Fleurs-de-lis of France; the 2d and 3d with a Lion of England;" borne by his grace John Manners, duke of Rutland, marquis of Granby, &c. This chief was anciently Gules; and the charge thereon is an honorary augmentation, showing his grace's descent from the blood-royal of King Edward IV.

20. "Barry of ten pieces Argent and Azure, over all six Escutcheons; 3, 2, 1, Sable, each charged with a Lion rampant of the first, armed, and langued Gules, a Crescent for difference;" borne by the right honourable James Cecil, earl of Salisbury, &c. This noble earl is descended from the famous *William Cecil*, Lord Burleigh, statesman in the reigns of Edward VI. and Elizabeth. This great man left two sons, Thomas and Robert, who were both made earls in one day, May 4. 1603. Robert, the younger son, ancestor of the present noble lord, was created earl of Salisbury in the morning; and Thomas, the eldest, earl of Exeter in the afternoon.

ART. 5. Of the CHEVERON.

The Cheveron, which represents two rafters of a house well joined together, or a pair of compasses half open, takes up the fifth part of the field with the English, but the French give it the third. Its diminutives are, The cheveronel, which contains the half of a cheveron; and the couple close, which is the half of a cheveronel, that is, its breadth is but the fourth part of a cheveron. Leigh observes, that this last diminutive is never borne but in pairs, or with a cheveron between two of them. The French have but one diminution of this ordinary called *Etaye*, containing the third part of its breadth.

Examples of cheverons are given in fig. 9. viz.

1. "Argent, a Cheveron Gules between three Torteaux;" borne by the right honourable Bennet Sherard, earl of Harborough, &c. This noble earl is lineally descended from Scherard, who was possessed of manors and lands to a great value in the counties of Cheshire and Lancashire in the reign of William the Conqueror. Geoffroy, another of the earl's ancestors, was three times sheriff of Rutlandshire, in the reigns of King Edward IV. and King Richard III.

2. "Sable, a Cheveron between three Etoiles Argent;" borne by the right honourable Marmaduke Langdale, Lord Langdale. This noble lord is descended from the Langdales of Yorkshire, who resided at the

town of Langdale, from whence they took their name, in the reign of King John; but his ancestor, who makes the greatest figure in history, is Sir Marmaduke Langdale, who raised forces in the north of England in defence of King Charles I.; was victorious in numberless battles and sieges; and when his majesty, by the united forces of England and Scotland, was at length overpowered, he attended King Charles II. in his exile, and returned to England with his majesty at the restoration.

3. "Sable, a Cheveron between three Leopards Heads Or;" borne by the right honourable William Wentworth, earl of Stafford, &c. All genealogists agree, that the name of *Wentworth* is of Saxon origin, and taken from the manor of Wentworth in Yorkshire, where, in the reign of William the Conqueror, lived Reginald de Wentworde, as it is spelt in Doomsday-book.

4. "Argent, a Cheveron between three Griffons passant Sable, a Crescent for difference;" borne by the right honourable Heneage Finch, earl of Ailesford, &c. This family is descended from Herbert Fitz-Herbert, earl of Pembroke, and chamberlain to King Henry I. They took the name of *Finch* in the reign of King Edward I. One of the ancestors of this family was the right honourable Heneage Finch, earl of Nottingham, who was constituted lord high-chancellor of England in 1675; and lord high-steward on the trials of Philip earl of Pembroke, and William Viscount Stafford, in 1680.

5. "Azure, a Cheveron Ermine, between three Escallops Argent;" borne by the right honourable George Townshend, Viscount Townshend, &c. This family is of Norman extraction, and came into England about the time of the Conquest. Charles, Lord Viscount Townshend, grandfather of the present viscount, was appointed principal secretary of state in the reign of King George I. in 1720, and continued so to the end of his majesty's reign; when, upon resigning the seals, they were returned to him again by his late majesty King George II. who continued him in that honourable office to the year 1730.

6. "Azure, a Cheveron between three Mulletts Or;" borne by the right honourable John Chetwind Viscount Chetwind, &c. of the kingdom of Ireland. Of this family, which hath been of great antiquity in the county of Salop, taking their surname from Chetwynd in that county, was Adam de Chetwynd, who married Agnes daughter of John Lord Lovel, baron of Dockinges, and lord of Minster Lovel in Oxfordshire; and by her had issue Sir John de Chetwynd, who, in the 37th of Henry III. had a charter of free-warren, through all his demesne in the counties of Salop, Stafford and Warwick.

7. "Argent, a Cheveron Gules, between three square Buckles Sable;" borne by the right honourable Matthew Ducie-Morton, Lord Ducie, &c. This noble lord is descended from the Ducies in Normandy. After they came into England, King Edward I. conferred on them the lordship of Morton in Staffordshire, and several other lordships and manors, which the family enjoyed for many years. Sir Robert Ducie, one of his lordship's ancestors, was lord mayor of London in the reign of King Charles I. and though he lent his majesty 80,000*l.* which was lost by the king's being

Of the
Cheveron.

Plate
CCLVI.

Of the
Cheveron.

driven out of London, he died, however, worth 40,000*l.*

8. "Argent, a Cheveron Checky Gules, and of the Field, between three Bugle-horns strung Sable, garnished of the second;" borne by the right honourable lord Hugh Semple, Lord Semple. The principal family of this name was Semple of Eliotson in Renfrewshire, where they had large possessions and offices, as stewards and bailiffs under the family of Stewart, proprietors of that county before they came to the crown. The first Lord Semple was Sir Robert, who being much in favour with King James IV. was by him created Lord Semple in 1489.

9. "Argent, a Cheveron engrailed between three Lions passant Sable;" borne by the right honourable and the reverend Philip Smithe, Viscount Strangford. One of this lord's ancestors was John Smithe, Esq. who acquired a considerable estate whilst he was farmer of the customs in the reign of Heary VIII. He left two sons, John and Sir Thomas; which last was sent ambassador by King James I. to the empress of Russia.

10. "Quarterly Argent and Azure, a Cheveron engrailed counter-changed;" borne by the name of Chamber.

11. "Party per Cheveron engrailed Gules and Argent, three Talbots Heads erased counter-changed;" borne by the right honourable Anthony Duncombe, Lord Feversham, &c. His lordship is descended from the Duncombes of Barley-end in Buckinghamshire. Sir Charles Duncombe, uncle to the present lord, was lord mayor of London in 1709; and this nobleman was created Lord Feversham and baron of Downton in Wiltshire, June 23. 1744.

12. "Paly of six, Argent and Gules, on a Cheveron Azure, three Cross-crolets Or;" borne by the name of Carpenter, Baron Carpenter, of Killaghy in Ireland. This ancient and noble family are of great antiquity in the county of Hereford, and have been lords of the manor of the Home, in the parish of Delwyn, near Weobly, for above 300 years. George, the first Lord Carpenter, was so created May 4. 1719.

13. "Azure, on a Cheveron Or, between three Besants, a Bay Leaf Proper;" borne by the right honourable James Hope, earl of Hopeton, &c. This noble family is descended from Henry Hope, a native of Holland, who, about two centuries ago, came over and settled in Scotland. Charles Hope, Esq. grandfather of the present earl, was created an earl by Queen Anne, April 15. 1703.

14. "Vert, on a Cheveron between three Unicorns Heads erased Argent, horned and maned Or, three Mulletts Sable;" borne by the name of Ker, being the 1st and 4th quarters in the arms of his grace John Ker, duke of Roxburgh, &c. This ancient family is said to come from Normandy. John Ker, marquis of Beaumont and Ceaford, the first duke of Roxburgh, was so created April 27. 1707.

15. "Azure, on a Cheveron Or, between three Bears Heads couped Argent, muzzled Gules, a Boobuck's Head erased, between two Hands holding Daggers all proper;" borne by the right honourable Donald Mackay, Lord Reay. This family is said to derive their descent from Alexander, a younger son of Ochonacker, who, about the end of the twelfth century,

came from Ireland; and the fourth in descent from him was Donald of Strathnavern, whose son was named *Y More*; and from him began the surname of *Mac Y, Mackie, or Mackay*. Donald, the first lord of this family, was created baronet in 1625, and on June 20. 1628, was created Baron Reay of the county of Caithness, by Charles I.

19. "Ermine, on a Cheveron Azure, three Foxes Heads erased Or, and in a Canton of the second a Fleur-de-lis of the third;" borne by the right honourable Stephen, earl of Ilchester, &c. Of the family of Fox there have been many persons of note living in the counties of Dorset, Somerset, Wilts, and Hants, particularly Richard Fox, bishop of Winchester. His lordship was created Lord Ilchester and Baron Strangeways, May 11. 1741, 14 George II. and earl of Ilchester in June 1756.

17. "Or, two Cheveronels Gules;" borne by the right honourable John Monson, Lord Monson. This noble lord is descended from John Monson, who flourished in the reign of King Edward III. from whom descended another John, who attended King Henry V. in his wars in France. Sir John Monson, Bart. father of the present lord, was created Lord Monson, May 28. 1718.

18. "Or, on a Fess, between two Cheveronels Sable, three Cross-crolets of the first;" borne by the right honourable George Walpole, earl of Orford, &c. This family took their name from Walpole in Norfolk, where they resided before the Conquest. Sir Robert Walpole was, in King George II.'s reign, elected knight of the Garter in 1726, and created earl of Orford, February 9. 1741-2.

19. "Azure, three Cheveronels interlaced Or, and a Chief of the last;" borne by the name of *Fitz-Hugh*.

20. "Argent, three Cheveronels Gules, in Chief a Label Azure;" borne by the right honourable William Wildman Barrington, Viscount Barrington, &c. This family is of Norman extraction; in which duchy, whilst it continued annexed to the English crown, there were to be seen the remains of a castle, bearing the name of *Chute, or Shute*, and formerly in the family, with other monuments in several towns of that duchy. John Shute, the late Viscount Barrington, was in 1708 made a commissioner of the customs, and succeeded to the estates of Francis Barrington, Esq. and of John Wildman of the county of Berks, who made him their heir; and in pursuance of the will of the former, he took the name and arms of *Barrington*. On June 11. 1720, he was created Viscount Barrington.

ART. 6. Of the CROSS.

The *Cross* is an ordinary formed by the meeting of two perpendicular with two horizontal lines in the fess-point, where they make four right angles; the lines are not drawn throughout, but discontinued the breadth of the ordinary, which takes up only the fifth part of the field when not charged; but if charged, then the third. It is borne as well engrailed, indented, &c. as plain.

There is so great a variety of crosses used in heraldry, that it would be a very difficult task to treat of them all. Guillim has mentioned 39 different sorts; De la Columbiere, 72; Leigh, 46; and Upton declares

Of the
Cross.

Of the
Cross.

he dares not ascertain all the various crosses borne in arms, for that they are almost innumerable; therefore, as their forms cannot be expected here, we will only take notice of such as are most commonly seen at present in coats-of-arms. See Fig. 10.

Plate
CCLVI.

The first is "Quarterly, Ermine and Azure, a Cross Or;" borne by his grace Thomas Osborne, duke of Leeds, &c. This noble duke is descended from the honourable family of the Osbornes of Ashford, in the county of Kent; Sir Thomas Osborne, the grandfather to the present duke, was advanced to the peerage by King Charles II.

2. "Gules, a Cross engrailed Argent, a Lozenge in the dexter-chief of the second;" borne by the right honourable Edward Leigh, Lord Leigh. This family took their surname from the town of High Leigh in Cheshire, where they resided before the Norman conquest. Sir Thomas Leigh, the first lord of this family, was created Baron Leigh of Stonely, by King Charles I. on July 1. 1643.

3. "Gules, a Cross Argent fretty Azure;" borne by the right honourable Nicholas Taaffe, Viscount Taaffe, of Corran, &c. in Ireland. Of this noble and ancient family was Richard Taaffe, who lived in 1282; as in 1306 did John Taaffe, who was archbishop of Armagh; and, in 1479, the order of the Garter being established in Ireland, Sir Nicholas Taaffe was one of the first members; and John, his son and heir, was created a baron and viscount by Charles I. August 1. 1628.

4. "Sable, a Cross raguly Or;" borne by the name of *Stoway*.

5. "Argent, on a Cross Sable, a Leopard's face Or;" borne by his grace Henry Brydges duke of Chandos, &c. The ancestors of this noble family took their name from the city of Bruges in Flanders; and one of them came over with William the Conqueror, and had a considerable share in the victory obtained near Hastings in Sussex, 1066. James, the father of the present duke, was created Viscount Wilton and earl of Caernarvon, October 19. 1714; and marquis of Caernarvon and duke of Chandos, — 30. 1719.

6. "Or, on a Cross Sable, a patriarchal Cross of the Field;" borne by the right honourable Thomas Vesey, baron of Knapton in the kingdom of Ireland. The truly noble family of Vescey or Vesey, derives its origin from Charles the Great, king of France, and emperor of the West, who died at Aix-la-Chapelle in Germany, January 28. 814. His lordship's father was created a peer April 10. 1750.

7. "Argent, on a Cross Gules, five Escallops Or;" borne by the right honourable William Villiers earl of Jersey, &c. This noble earl is descended from the family of Villiers in Normandy, some of whom came over to England with the Conqueror; several manors and lands in England being soon after granted to Pagan de Villiers, one of this earl's ancestors. The first peer of this family was created a baron and viscount, March 20. 1690.

8. "Sable, on a Cross within a Bordure engrailed Or, five Pellets;" borne by the right honourable Francis Greville, earl of Brooke and Warwick, &c. The ancestors of this noble family are of Norman extraction, and came over with William the Conqueror, who conferred manors and lands on them in England,

of a considerable value; and at length they obtained the government of the castle of Warwick, the present seat of the family. Sir Fulke, the first peer of this family, was created Baron Brooke by King James I. January 9. 1620.

9. "Argent, a Cross bottony Sable," borne by the name of *Winwood*.

10. "Or, a Cross-croset Gules," borne by the name of *Taddington*.

11. "Azure, a Cross potent fitchy Or." This ensign is said to have been borne by Ethelred king of the West Saxons; and crosses of this sort are frequently met with in coats of arms.

12. "Party per pale, Gules and Argent; a Cross potent quadrate in the Centre, between four Crosses patee counter-changed;" the arms of the episcopal see of Litchfield and Coventry. This see was originally fixed at Litchfield; from thence removed to Chester, and from both to Coventry. It contains the whole county of Stafford, except two parishes; all Derbyshire; the better part of Warwickshire, and near half Shropshire; divided into the four archdeaconries of Coventry, Stafford, Derby, and Salop. The parishes are 557 in number; but, including chapels, they amount to 643.

13. "Azure, a Cross moline Argent;" borne by his grace Cavendish Bentinck, duke of Portland, &c. This noble duke is descended from a very ancient and distinguished family in the United Provinces of Holland, of which was William Bentinck, Esq. who in his youth was page of honour to William prince of Orange, afterwards William III. king of Great Britain, and, on the accession of William and his consort, was made groom of the stole, privy-purse to his majesty, lieutenant-general of his majesty's army, &c. and also created baron of Cirencester, Viscount Woodstock, and earl of Portland, April 19. 1689.

14. "Argent, a Cross patonce Sable;" borne by the name of *Rice*.

15. "Sable, a Cross patee Argent;" borne by the name of *Maplesden*.

16. "Azure, a Cross flowery Or;" borne by the name of *Cheney*.—This is said to have also been the arms of Edwin, the first Christian king of Northumberland.

17. "Argent, six Cross-crosetts fitchy 3, 2, 1, Sable, on a Chief Azure, two Mulletts pierced Or," borne by his grace Henry Clinton, duke of Newcastle, &c. This noble family is descended from Jeffrey de Clinton, lord chamberlain and treasurer to King Henry I. grandson to William de Tankerville, chamberlain of Normandy; from whom descended William de Clinton, chief justice of Chester, governor of Dover castle, lord warden of the king's forests south of Trent. Edward Lord Clinton, another of this noble earl's ancestors, was constituted lord high admiral of England for life, in the reign of Queen Elizabeth, who created him earl of Lincoln, May 4. 1572.

18. "Gules, a Chevron between ten Crosses patee, six above and four below, Argent;" borne by the right honourable Frederick Augustus Berkeley, earl of Berkeley, &c. This noble family is descended from Robert Fitz-Harding, who obtained a grant of Berkeley

Of the
Cross.

ley-castle in Gloucestershire, which the family still inherits, and from whence they obtained the surname of *Berkeley*, from Henry duke of Normandy, afterwards king of England; the said Robert Fitz-Harding was descended from the royal line of the kings of Denmark.

19. "Azure, three mullets Or, accompanied with seven Cross-crolets fitchy Argent, three in Chief, one in Fess, two in Flanks, and the last in Base;" borne by the right honourable James Somerville, Lord Somerville. The first of this name on record is Sir Walter de Somerville, lord of Wichmore, in the county of Stafford, who came to England with William the Conqueror.

20. "Gules, three Crosses recercelée, voided Or, a Chief vary ermine and contre ermine;" borne by the right honourable John Peyto Verney, Baron Willoughby de Broke. This noble lord is descended from William de Vernai, who flourished in the reign of King Henry I. 1119.

ART. 7. Of the SALTIER.

The Saltier, which is formed by the bend and bend sinister crossing each other in right angles, as the intersecting of the pale and fess forms the cross, contains the fifth part of the field; but if charged, then the third. In Scotland, this ordinary is frequently called a *St Andrew's Cross*. It may, like the others, be borne engrailed, wavy, &c. as also between charges or charged with any thing. See examples, fig. 11.

N^o 1. is "Argent, a Saltier Gules;" borne by his grace James Fitz-Gerald, duke of Leinster, &c. This noble lord is descended from Otho, or Other, a rich and powerful lord in the time of King Alfred, descended from the dukes of Tuscany; who passing from Florence into Normandy, and thence into England, there the family flourished, until Richard Strongbow, earl of Pembroke, their kinsman, engaged them to partake in his expedition to Ireland, in which Maurice Fitz-Gerald embarked, and was one of the principal conquerors of that kingdom, for which he was rewarded with a great estate in lands in the province of Leinster, and particularly the barony of Offaley, and the castle of Wicklow; and died, covered with honours, in the year 1177, 24 Henry II.

2. "Gules, a Saltier Argent, between twelve Cross-crolets Or;" borne by the right hon. Other-Lewis Windsor Hickman, earl of Plymouth, &c. This noble earl is descended from Robert Fitz-Hicman, lord of the manor of Bloxham, Oxfordshire, in the 56 Hen. III. 1272; and he is maternally descended from the noble family of the Windsors, who were barons of the realm at the time of the Conquest.

3. "Vert, a Saltier wavy Ermine;" borne by the name of *Wakeman* of Beckford, in Gloucestershire.

4. "Ermine, a Saltier counter-compony Or and Gules;" borne by the name of *Ulmston*.

5. "Argent, a Saltier Azure with a Bezant in the centre;" borne by the right hon. Philip Yorke, earl of Hardwicke, &c. He was in October 1733 constituted lord chief-justice of the king's bench, and November 23. in the same year, created Baron Hardwicke of Hardwicke.

6. "Argent on a Saltier Gules an Escallop Or;"

the arms of the bishoprick of Rochester.—This diocese, the least in England, comprehends only a small part of Kent, in which there are 150 churches and chapels; and the two parishes of Iselham in Cambridgeshire, and Frekenham, in Suffolk. It has only one archdeacon, that of Rochester. For many years it was in the immediate patronage of the archbishop of Canterbury.

7. "Party per Saltiere, Azure and Argent, on a Saltier Gules, a Crescent of the second for difference;" quartered by the right hon. William Hall Gage, Viscount Gage, of Castle-Island in Ireland. This noble family is of Norman extraction, and derives descent from de Gaga or Gage, who attended William I. in his expedition to England; and, after the conquest thereof, was rewarded with large grants of lands in the forest of Dean, and county of Gloucester, near which forest he fixed his residence, by building his seat at Glerenwell, in the same place where the house of Gage now stands: he also built a great house in the town of Cirencester, at which place he died, and was buried in the abbey there. Sir Thomas Gage, the eighth baronet, was created baron of Castle-Bar, and Viscount Gage, 1721.

8. "Gules, on a Saltier Argent, a Rose of the first barbed and seeded proper;" borne by the right hon. George Neville, Lord Abergavenny, premier baron of England.

9. "Or, on a Saltier Azure, nine Lozenges of the first;" the paternal arms of the right hon. John Dalrymple, earl of Stair, &c. Of this family, which took their surname from the barony of Dalrymple, lying on the river Dun in Ayrshire, Scotland, was Adam de Dalrymple, who lived in the reign of Alexander III.

10. "Argent, on a Saltier engrailed Sable, nine Annulets Or;" borne by the name of *Leak*.

11. "Gules, a Saltier between four Crescents Or;" borne as the second and third quarters in the coat-of-arms of the right honourable Charles Kinnaird, Lord Kinnaird. George Kinnaird, Esq. one of the present lord's ancestors, being of great service to King Charles II. during the usurpation of Oliver Cromwell, he was by that prince, at his restoration, made one of the privy-council; and December 28. 1682, created a baron.

12. "Argent, a Saltier engrailed between four Roses Gules," for Lennox; and borne as first and fourth quarters in the coat-of-arms of the right hon. Francis Napier, Lord Napier. This family is said to be descended from the ancient thanes or stewards of Lennox in Scotland, but took the surname of Napier from the following event. King David II. in his wars with the English, about the year 1344, convocating his subjects to battle, the earl of Lennox sent his second son Donald, with such forces as his duty obliged him; and coming to an engagement, where the Scots gave ground, this Donald, taking his father's standard from the bearer, and valiantly charging the enemy with the Lennox men, the fortune of the battle changed; and they obtained the victory: whereupon every one advancing, and reporting their acts, as the custom was, the king declared they had all behaved valiantly, but that there was one among them who had *na pier*, that is, no equal; upon which the said Donald took the

Of the
Saltier.

name of Napier, and had, in reward for his good services, the lands of Gosfield, and other estates in the county of Fife.

13. "Gules, a Saltier Or, surmounted of another Vert;" for the name of *Andrews*; and borne by Sir William Andrews, bart. of Denton in Northamptonshire, who is descended from Sir Robert Andrews of Normandy, knight, who came into England with William the Conqueror. Sir William Andrews, the first baronet of this family, was created December 11. 1641.

14. "Azure, a Saltier quarterly quartered Or and Argent." The arms of the episcopal see of Bath and Wells.—The diocese of Bath and Wells contains all Somersetshire, except a few churches in Bristol. And in it there are three archdeaconries, viz. those of Wells, Bath, and Taunton. The number of the parishes is 388, though, according to some, the total number of the churches and chapels amounts to 503.

15. "Party per Saltier Argent and Gules, a Saltier counter-changed."

16. "Party per Pale indented Argent and Sable, a Saltier counter-changed;" borne by the name of *Scote*.

17. "Argent, three Saltiers coupé and engrailed Sable;" borne by the name of *Benton*.

18. "Argent, a Saltier Gules, and a chief Ermine;" borne by the right hon. Francis Thomas Fitz-Maurice, earl of Kerry, &c. This very ancient and noble family is a branch of the family of Kildare, who are originally descended from the great duke of Tuscany, and of which was Otho, a noble baron of Italy, whose son Walter, attending the Norman conqueror into England, was made constable of the castle of Windsor. Raymond, one of the present earl's ancestors, had a principal hand in the reduction of Ireland to the subjection of Henry II. and Dermoid Mac-Carty, king of Cork, sought his aid against his son Cormac O'Lehanagh, which he undertook, and delivered the king from his rebellious son; for which that prince rewarded him with a large tract of land in the county of Kerry, where he settled his son Maurice, who gave his name to the county, which he called *Clan-Maurice*, and is enjoyed by the present earl of Kerry, who is Viscount Clan-Maurice. Thomas the first earl, and father of the last, was the 21st Lord Kerry, who was created earl January 17. 1722.

19. "Sable, a Saltier Argent, on a Chief Azure, three Fleurs-de-lis Or;" borne by the right hon. John Fitz-Patrick, earl of Upper Ossory, and baron of Gowran in Ireland. This most ancient and princely family is descended from Heremon, the first monarch of the Milesian race in Ireland; and after they had assumed the surname of Fitz-Patrick, they were for many ages kings of Ossory, in the province of Leinster. John, the first earl of this family, succeeded his father Richard as Lord Gowran, June 9. 1727, was created earl October 5. 1751, and died 1758.

20. "Party per Pale Argent and Gules, three Saltiers counter-changed;" borne by the name of *Lane*. These arms are also borne, without the least alteration, by the name of *Kingsman*; for which similitude we can no otherwise account, than by supposing there has been some mistake made through many transcriptions.

SECT. II. Of Sub-Ordinaries.

Sub-
Ordinaries.

BESIDES the honourable ordinaries and the diminutions already mentioned, there are other heraldic figures, called *sub-ordinaries*, or *ordinaries* only, which, by reason of their ancient use in arms, are of worthy bearing; viz. The Gyron, Franc-quarter, Canton, Pairle, Fret, Pile, Orle, Inescutcheon, Treasure, Anulet, Flanches, Flasques, Voiders, Billet, Lozenge, Guts, Fusil, Rustre, Mascle, Papillone, and Diaper. See Plate CCLIV. fig. 1. (A.)

The Gyron is a triangular figure formed by two lines, one drawn diagonally from one of the four angles to the centre of the shield, and the other is drawn either horizontal or perpendicular, from one of the sides of the shield, meeting the other line at the centre of the field.

Gyronny is said, when the field is covered with six, eight, ten, or twelve gyrons in a coat-of-arms: but a French author would have the true gyronny to consist of eight pieces only, as in the fig. which represents the coat-of-arms of Flora Campbell countess of Loudon, &c. whose ancestor was created baron of Loudon in 1604 by James VI. and earl of the same place, May 12. 1633, the 9th of Charles I.

The Franc-quarter is a square figure, which occupies the upper dexter quarter of the shield. It is but rarely carried as a charge. *Silvestra Petra Sancta* has given us a few instances of its use.

The Canton is a square part of the escutcheon, somewhat less than the quarter, but without any fixed proportion. It represents the banner that was given to ancient knights-bannerets, and, generally speaking, possesses the dexter-chief point of the shield, as in the fig.; but should it possess the sinister corner, which is but seldom, it must be blazoned a canton-sinister.

James Cotes reckons it as one of the nine honourable ordinaries, contrary to most heralds opinion. It is added to coats of arms of military men as an augmentation of honour: thus John Churchill, baron of Eyemouth in Scotland, and one of the ancestors of the present duke of Marlborough, being lieutenant general to King James II. received from him a canton argent, charged with the red-cross of England, added to his paternal coat, "which is Sable, a lion rampant Argent."

The Pairle is a figure formed by the conjunction of the upper half of the saltier with the under half of the pale.

The Fret is a figure representing two little sticks in saltier, with a mascle in the centre interlaced. J. Gibbon terms it, the *heralds true-lovers knot*; but many dissent from his opinion.

Fretty is said when the field or bearings are covered with a fret of six, eight, or more pieces, as in the fig. The word *fretty* may be used without addition, when it is of eight pieces; but if there be less than that number, they must be specified.

The Pile, which consists of two lines, terminating in a point, is formed like a wedge, and is borne engrailed, wavy, &c. as in the fig. It issues in general from the chief, and extends towards the base; yet there are some piles borne in bend, and issuing from other parts.

Sub-Ordinaries. parts of the field, as may be seen in Plate CCLVII. fig. 12. N^o 12, &c.

Green } they are called { *de Vert*
Black } { *de Poix*.

Sub-Ordinaries.

The Orle is an ordinary composed of two lines going round the shield, the same as the bordure, but its breadth is but one half of the latter, and at some distance from the brim of the shield, as in the fig.

The Inescutcheon is a little escutcheon borne within the shield; which according to Guillim's opinion, is only to be so called when it is borne single in the fess point or centre; see the fig. on Plate CCLIV. but modern heralds, with more propriety, give the name of *inescutcheon* to such as are contained in Plate CCLVII. fig. 12. N^o 2. and call that which is fixed on the fess-point *escutcheon of pretence*, which is to contain the arms of a wife that is an heiress, as mentioned above.

The Tressure is an ordinary commonly supposed to be the half of the breadth of an orle, and is generally borne flowery and counter-flowery, as it is also very often double, and sometimes treble. See the fig. (Plate CCLIV.). This double tressure makes part of the arms of Scotland, as marshalled in the royal achievement, Plate CCLIX. fig. 21. N^o 7: and was granted to the Scots king by Charlemagne, being then emperor and king of France, when he entered into a league with Achaius king of Scotland, to show that the French lilies should defend and guard the Scottish lion.

Plate CCLIV. The Annuet, or ring, is a well-known figure, and is frequently to be found in arms through every kingdom in Europe.

The Flanches are formed by two curved lines, or semicircles, being always borne double. See the figure. W. Leigh observes, that on two such Flanches two sundry coats may be borne.

The Flasques resemble the flanches, except that the circular lines do not go so near the centre of the field; (see the figure). J. Gibbon would have these two ordinaries to be both one, and wrote *flank*; alleging that the two other names are but a corruption of this last: but as G. Leigh and J. Guillim make them two distinct and subordinate ordinaries, we have inserted them here as such.

The Voiders are by Guillim considered as a subordinate ordinary, and are not unlike the flasques (see the figure), but they occupy less of the field.

The Billet is an oblong square figure, twice as long as broad. Some heralds imagine, that they represent bricks for building; others more properly consider them as representing folded paper or letters.

The Lozenge is an ordinary of four equal and parallel sides, but not rectangular; two of its opposite angles being acute, and the other two obtuse. Its shape is the same with those of our window-glasses, before the square came so much in fashion. See the figure.

Gutts, or drops, are round at bottom, waved on the sides, and terminate at the top in points. Herald's have given them different names according to their different tinctures: thus if they are

Yellow }
White } they are called { *d'Or*
Red } { *d'Eau*
Blue } { *de Sang*
 } { *de Larmes*

The Fusil is longer than the lozenge, having its upper and lower part more acute and sharp than the other two collateral middle parts, which acuteness is occasioned by the short distance of the space between the two collateral angles; which space, if the fusil is rightly made, is always shorter than any of the four equal geometrical lines whereof it is composed. See the fig. *ibid*.

The Rustre is a lozenge pierced round in the middle (see the figure). They are called by the German *rusten*. Menestrier gives an example of them in the arms of Lebarett in France, argent three rustres azure.

The Mascle is pretty much like a lozenge, but voided or perforated through its whole extent, showing a narrow border, as in the figure. Authors are divided about the resemblance; some taking it for the mash of a net, and others for the spots of certain flints found about Rohan; and as no writer has given a clearer account in support of this last opinion than Columbiere, author of *La Science Heraldique*, we shall transcribe it for the satisfaction of the curious.

"Rohan (says he) bears Gules, nine Mascles, Or, 3, 3, 3. Opinions have varied very much about the original of the mascles or mashes, as being somewhat like the mashes of nets: but for my own part, having often observed that those things which are remarkable and singular in some countries, have sometimes occasioned the lords thereof to represent them in their escutcheons, and to take them for their arms, I am of opinion, that the lords of Rohan, who, I believe, are the first that bore these figures in their arms though descended from the ancient kings and princes of Bretagne, took them, because in the most ancient viscounty of Rohan, afterwards erected into a duchy, there are abundance of small flints, which being cut in two, this figure appears on the inside of them; as also the carps, which are in the fish-ponds of that duchy, have the same mark upon their scales; which, being very extraordinary and peculiar to that country, the ancient lords of the same had good reason, upon observing that wonder, to take those figures for their arms, and to transmit them to their posterity, giving them the name of *macles*, from the Latin word *macula*, signifying a spot; whence some of that house have taken for their motto, *Sine macula macla*, that is, A mascle without a spot."

Papillone is an expression used for a field or charge that is covered with figures like the scales of a fish. Mons. Baron gives as an example of it the arms of Monti, Gueules Papellone d'Argent. The proper term for it in English would be *scallop work*.

Diapering is said of a field or charge shadowed with flourishings or foliage with a colour a little darker than that on which it is wrought. The Germans frequently use it; but it does not enter into the blazoning or description of an arms, it only serves to embellish the coat.

If the fore-mentioned ordinaries have any attributes, that is, if they are engrailed, indented, wavy, &c. they must be distinctly specified, after the same manner as the honourable ordinaries.

See examples of subordinaries, &c. fig. xii.

1. "Gules,

Sub-Ordinaries.
Plate
CCLVII.

1. "Gules, an Orle Ermine;" borne by the name of *Humfraville*.
2. "Argent, three Inescutcheons Gules;" borne by the name of Hay, and the 2d and 3d quarters in the coat-of-arms of the right hon. Thomas Hay, earl of Kinnoul, &c.—The first of the name of Hay that bore these arms, got them, as Mr Nisbet observes, because he and his two sons, after having defeated a party of the Danes at the battle of Loncarty, anno 942, were brought to the king with their shields all stained with blood.
3. "Argent, a Fret Sable;" borne by the right hon. Lionel Talmash, earl of Dysart, &c. This family was advanced to the peerage by King Charles I. in 1646.
4. "Or fretty of Gules, a Canton Ermine;" borne by the right hon. Henry Noel, earl of Gainsborough, &c. This nobleman is descended from — Noel, who came into England with William the Conqueror, and, in consideration of his services, obtained a grant of several manors and lands of very great value. Sir Edward, who was knighted by King James on his accession to the throne, and created a baronet June 29. 1611, was the first advanced to the honour of Baron Noel, March 23. 1616.
5. "Girony of eight Pieces Or and Sable;" the 1st and 4th quarters of the coat-of-arms of the right hon. John Campbell, earl of Breadalbane, &c. This ancient and noble family is descended, in a regular succession, from Duncan the first Lord Campbell, ancestor of the family of Argyll. John, the first earl, in consideration of his personal merit, was, from a baronet, created Lord Campbell, Viscount Glenorchie, and earl of Breadalbane, Jan. 28. 1677, by Charles II.
6. "Lozengy Argent and Gules;" borne by the right hon. George Fitz-William, Earl Fitz-William, &c. This noble earl is descended from Sir William Fitz-William, marshal of the army of William the Conqueror at the battle of Hastings in Sussex, by which victory that prince made his way to the throne.
7. "Sable, a Masle within a Tressure flowery Argent;" borne by the name of *Hoblethorne*.
8. "Gules, three Mullets Or, within a Bordure of the latter, charged with a double Tressure flowery, and counter-flowery with Fleurs-de-lis of the first;" borne by the noble family of Sutherland, &c. This family, in the peerage, is among the oldest in Britain, if not in all Europe; the title of *earl* being conferred on one of their ancestors in 1067.
9. "Azure, a Pile Ermine," for the name of *Wyche*; and is quartered as first and fourth in the coat-of-arms of Sir Cyril Wyche, Bart.
10. "Or, on a Pile engrailed Azure, three Cross-crosets fitchy of the first;" borne by the name of *Rigdon*.
11. "Or, on a Pile Gules, three Lions of England between six Fleurs-de-lis Azure;" the first and fourth quarters of his grace Edward Seymour, duke of Somerset, &c. granted him by King Henry VIII. on his marriage with the lady Jane Seymour.
12. "Ermine, two Piles issuing from the dexter and sinister sides, and meeting in base Sable;" for the name of *Holles*.
13. "Argent, three Piles, one issuing from the Chief

between the others reversed, Sable;" for the name of *Hulse*, and borne by Sir Edward Hulse, Bart.

14. "Azure, a Pile wavy bendways Or;" borne by the name of *Aldham*.—There is no mention made of its issuing out of the dexter corner of the escutcheon, for this is sufficiently determined by the term *bendways*.

15. "Or, three Piles in Bend, each point enseigned with a Fleur-de-lis Sable;" borne by the name of *Norton*.

16. "Argent, three Piles meeting near the point of the base Azure;" borne by the name of *Bryan*.

17. "Party per Pale and per Bend Or and Azure counterchanged;" borne by the name of *Johnson*.—This bearing is equal to two gyrons; see p. 412. col. 2.

18. "Party per Pale and per Chevron Argent and Gules counterchanged."

19. "Party per Pale chappé Or and Vert counterchanged." This is a bearing seldom to be met with.

20. "Party per Fess Gules and Argent, a Pale counterchanged;" borne by the name of *Lavider*.

SECT. III. Of Common Charges borne in Coats-of-arms.

It has been already observed, that in all ages men have made use of the representation of living creatures, and other symbolical signs, to distinguish themselves in war; and that these marks, which were promiscuously used for hieroglyphics, emblems, and personal devices, gave the first notion of heraldry. But nothing shows the extent of human wit more, than the great variety of these marks of distinction, since they are composed of all sorts of figures, some natural, others artificial, and many chimerical; in allusion, it is to be supposed, to the state, quality, or inclination of the bearer.

Hence it is, that the sun, moon, stars, comets, meteors, &c. have been introduced to denote glory, grandeur, power, &c. Lions, leopards, tygers, serpents, stags, &c. have been employed to signify courage, strength, prudence, swiftness, &c.

The application to certain exercises, such as war, hunting, music, &c. has furnished lances, swords, pikes, arms, fiddles, &c.; architecture, columns, chevrons, &c.; and the other arts several things that relate to them.

Human bodies, or distinct parts of them, also clothes, and ornaments, have, for some particular intention, found place in armory; trees, plants, fruits, and flowers, have likewise been admitted to denote the rarities, advantages, and singularities, of different countries.

The relation of some creatures, figures, &c. to particular names, has been likewise a very fruitful source of variety in arms. Thus the family of Coningsby bears three coney; of Arundel, six swallows; of Urson, a bear; of Lucie, three pikes, in Latin *tres lucios pisces*; of Starkey, a stork; of Castleman, a castle triple-towered; of Shuttleworth, three weavers shuttles, &c.

Besides these natural and artificial figures, there are chimerical or imaginary ones used in heraldry, the result of fancy and caprice; such as centaurs, hydras, phoenixes, griffons, dragons, &c. Which great variety of figures shows the impossibility of comprehending all

common

Natural Figures. common charges in a work of this nature; therefore such only shall be treated of as are most frequently borne in coats-of-arms.

ART. I. Of Natural Figures borne in Coats-of-arms.

Among the multitude of natural things which are used in coats-of-arms, those most usually borne are, for the sake of brevity as well as perspicuity, distributed into the following classes, viz.

Celestial figures; as, the sun, moon, stars, &c. and their parts.

Effgies of men, women, &c. and their parts.

Beasts; as, lions, stags, foxes, boars, &c. and their parts.

Birds; as, eagles, swans, storks, pelicans, &c. and their parts.

Fishes; as dolphins, whales, sturgeons, trouts, &c. and their parts.

Reptiles and *insects*; as, tortoises, serpents, grasshoppers, &c. and their parts.

Vegetables; as trees, plants, flowers, herbs, &c. and their parts.

Stones; as diamonds, rubies, pebbles, rocks, &c.

These charges have, as well as ordinaries, divers attributes or epithets, which express their qualities, positions, and dispositions. Thus the sun is said to be *in his glory, eclipsed, &c.*; the moon, *in her complement, increscent, &c.* Animals are said to be *rampant, passant, &c.* Birds have also their denominations such as *close, displayed, &c.* Fishes are described to be *hauriant, naiant, &c.*

I. Examples of Celestial Figures.

1. "Azure, a Sun in his Glory;" borne by the name of *St Clere*; and is found in the first and fourth quarters of the coat-of-arms of the most noble William-John Ker, marquis of Lothian, &c. It is needless to express the colour of the sun, nothing being capable to denote it but gold.

2. "Azur, one Ray of the Sun, bendways Gules, between six Beams of that Luminary Argent;" borne by the name of *Aldam*. There is no mention made of their issuing out of the dexter-corner of the escutcheon; for this is implied in the term *bendways*, for the reason mentioned before.

3. "Argent, five rays of the Sun issuing out of the sinister corner Gules;" borne by the name of *Mudshideler*, a family of distinction in Franconia.

4. "Or, a Sun eclipsed." This bearing is seldom to be met with, except in emblematic or hieroglyphic figures; and might be expressed *Sable*, because that hue is accidental and not natural.

5. "Gules, the Moon in her complement Or, illustrated with all her light proper." This is sufficient without naming the colour, which is *Argent*.

6. "Azure, a Moon decrescent proper;" borne by the name of *Delaluna*.

7. "Gules, a Moon increscent Or;" borne by the name of *Descus*.

8. "Argent, a Moon in her detriment, Sable." This word is used in heraldry to denote her being eclipsed,

9. "Azur, a Crescent Argent;" borne by the name of *Lucy*. This bearing is also used as a differ-

ence, it being assigned to the second son, as before-mentioned.

10. "Gules, three Crescents Argent;" borne by Oliphant, Lord Oliphant (at present dormant). Amongst the ancestors of this noble family was David de Oliphant, one of those barons who, in 1142, accompanied King David I. into England with an army, to assist his niece Matilda, against King Stephen; but after raising the siege of Winchester, the said King David was so closely pursued, that had it not been for the singular conduct of this brave person, the king would have been taken prisoner.

11. "Azure, a Crescent between three Mulletts Argent;" borne by Arbuthnot, Viscount and Baron Arbuthnot. In the year 1105, the first of this family marrying a daughter of the family of Oliphant, sheriff of the county of Kincardine, with her he had the lands of Arbuthnot in that county, from whence he took his surname. Robert Arbuthnot was the first of this family who, for his loyalty to King Charles I. was, Nov. 16. 1641, dignified with the title of *Baron* and *Viscount Arbuthnot*.

12. "Gules, a Star issuing from between the Horns of a Crescent Argent."

13. "Azure, a Star of 16 points Argent;" borne by the name of *Huitson*.

14. "Argent, three Mulletts pierced Sable;" borne by the name of *Wollaston*.

15. "Azur, six Mulletts, 3, 2, 1, Or;" borne by the name of *Welsh*.

16. "Ermine, a Mullet of six points Gules, pierced;" borne by the name of *Hessenhul*.—When a mullet has more than five points, their number must, in blazoning, be always named.

17. "Argent, a Rainbow with a Cloud at each end proper." This is part of the crest to the earl of Hopeton's coat-of-arms, which is inserted in fig. ix. N^o 13. The whole of it is a globe split on the top, and above it is the rainbow, &c.

18. "Party per Fess crenelle Gules and Azure, three Suns proper;" borne by the name of *Piercion*.

19. "Gules, a Mullet between three Crescents Argent;" borne by the name of *Oliver*.

20. "Gules, a Chief Argent, on the lower part thereof a Cloud, the Sun's resplendent rays issuing throughout proper;" borne by the name of *Leeson*.

II. Examples of Effgies of Men, &c. and their Parts.

1. "Azur, the Virgin Mary crowned, with her Babe in her right arm and a sceptre in her left, all Or;" the coat-of-arms of the bishoprick of Salisbury. Fig. 14.

2. "Azur, a Presbyter sitting on a Tomb-stone, with a Crown on his head and a Glory Or, his right hand extended, and holding in his left an open Book Argent, with a sword cross his mouth Gules;" the coat-of-arms of the bishoprick of Chichester.

3. "Azur, a Bishop habited in his pontificals sitting on a chair of state, and leaning on the sinister side thereof, holding in his left hand a Crosier, his right being extended towards the dexter chief of the escutcheon, all Or, and resting his feet on a cushion Gules, tasseled of the second;" the coat-of-arms of the bishoprick of Clogher in Ireland.

4. "Azur, a Bishop habited in his pontificals, holding before him, in a Pale, a Crucifix proper;"

Plate CCLVII. fig. 13.

Effigies
of Men.

the coat of arms of the bishop of Waterford in Ireland.

5. "Or, a man's Leg couped at the midst of the thigh Azure;" borne by the name of *Haddon*.

6. "Azure, three sinister hands couped at the wrist, and erected Argent;" borne by the ancient family of *Malmains*.

7. "Argent, three sinister hands couped at the wrist, and erected Gules;" borne by the name of *Maynard*.—By these two last examples it appears that different coats of arms may be easily made from the same figure or figures, by varying the colours only, without the addition of any other charge, counter-changings, partings, &c.

8. "Argent, a Man's Leg erased at the midst of the thigh Sable;" borne by the name of *Prime*.

9. "Gules, three Legs armed proper, conjoined in the Fess point at the upper part of the thighs, flexed in triangles, garnished and spurred, Or." This is the coat of arms of the Isle of Man; and is quartered by the most noble John Murray, duke of Athol, titular lord or king of that isle.

10. "Gules, three dexter Arms vambraced fess-ways, in Pale proper;" borne by the name of *Armstrong*. This coat is very well adapted to the bearer's name, and serves to denote a man of excellent conduct and valour.

11. "Or, three Legs couped above the knee Sable;" borne by the name of *Hosy*.

12. "Vert, three dexter Arms conjoined at the shoulders in the Fess-point, and flexed in triangle Or, with fists clenched Argent;" borne by the name of *Tremain*.

13. "Argent, a Man's Heart Gules, with two equilateral triangles interlaced Sable;" borne by the name of *Villages*, a family of distinction in Provence.

14. "Azure, a sinister Arm, issuing out of the dexter-chief, and extended towards the sinister-base Argent."

15. "Argent, a dexter Hand couped at the wrist, and erected, within a bordure engrailed Sable;" borne by the name of *Manley*.

16. "Argent, a Man's Heart Gules, ensigned with a Crown Or, and on a Chief Azure, three Mulletts of the first." The paternal coat of the name of *Douglas*, and quartered in the arms of the dukes of Hamilton and Queensberry; as also in those of the earls of Morton and March, and the lord Mordington.

17. "Gules, a Saracen's Head affrontée, erased at the neck Argent, environed about the temples with a wreath of the second and Sable;" borne by the name of *Mergith*.

18. "Argent, three Blackamoors Heads couped proper, banded about the head Argent and Gules;" borne by the name of *Tanner*.

19. "Gules, three Besants, each charged with a man's face affrontée proper;" borne by the name of *Gamin*.

20. "Or, a Blackamoor's Head couped proper, banded about the head Argent;" borne by the name of *Ustoc*.

Observe, that when half of the face, or little more, of human figures, is seen in a field, it is then said to be *in profile*; and when the head of a man, woman, or

other animal, is represented with a full face, then it is termed *affrontée*.

Positions
of Lions.

III. Examples of the different Positions of Lions, &c. in Coats-of-Arms.

1. "Or, a Lion rampant Gules;" quartered by *Percy*, duke of Northumberland, &c.

2. "Azure, a Lion rampant-guardant Or;" borne by the name of *Fitz-Hammond*.

3. "Gules, a Lion rampant-reguardant Or;" quartered by *Cadogan*, Lord Cadogan, &c.

4. "Ermine, a Lion saliant Gules;" borne by the name of *Worley*.

5. "Azure, a Lion statant-guardant Or;" borne by the name of *Bromfield*.

6. "Or, a Lion passant Gules;" borne by the name of *Games*.

7. "Argent, a Lion passant guardant Gules crowned Or;" quartered by the right honourable James Ogilvy, earl of Findlater, &c.

8. "Gules, a Lion sejant Argent."

9. "Or, a Lion rampant double-headed Azure;" borne by the name of *Mason*.

10. "Sable, two Lions rampant-combatant Or, armed and langued Gules;" borne by the name of *Carter*.

11. "Azure, two Lions rampant-adossée Or." This coat-of-arms is said to have been borne by Achilles at the siege of Troy.

12. "Sable, two Lioncels counter-passant Argent, the uppermost towards the sinister side of the escutcheon, both collared Gules;" borne by the name of *Glegg*.—It is the natural disposition of the lion not to bear a rival in the field: therefore two lions cannot be borne in one coat-of-arms, but must be supposed to be lion's whelps, called *lioncels*; except when they are parted by an ordinary, as in fig. viii. N^o 17. or so disposed as that they seem to be distinctly separated from each other, as in fig. xv. N^o 20. In the two foregoing examples they are called *lions*, because in the 10th they seem to be striving for the sovereignty of the field, which they would not do unless they were of full growth; and in the 11th they are supposed to represent two valiant men, whose dispute being accommodated by the prince, are leaving the field, their pride not suffering them to go both one way.

13. "Argent, a Demi-lion rampant Sable;" borne by the name of *Mervin*.

14. "Gules, a Lion couchant between six Cross-crosetts, three in Chief, and as many in Base, Argent;" for the name of *Tynte*; and is the first and fourth quarter of the arms of Sir Charles-Kemys Tynte, Bart.

15. "Azure, a Lion dormant Or."

16. "Or, out of the midst of a Fess Sable, a Lion rampant naissant Gules;" borne by the name of *Emme*. This form of blazon is peculiar to all living things that shall be found issuing out of the midst of some ordinary or other charge.

17. "Azure, three Lioncels rampant Or;" borne by *Fienes*, Viscount and Baron Saye and Sele.

18. "Gules, a tricorporated Lion issuing from three parts of the Escutcheon, all meeting under one Head in the Fess-point Or, langued and armed Azure;" borne

Different
Animals.

borne by the name of *Crouchback*. This coat appertained to Edmund Crouchback earl of Lancaster, in the reign of his brother King Edward I.

19. "Gules, a besant between three Demi-lions rampant Argent;" borne by Benmet, earl of Tankerville, &c. This noble earl is descended from the family of the Bennets in Berkshire, who flourished in the reign of King Edward III. Charles, Lord Ossulston, was created earl of Tankerville on October 19. 1714, by George I.

20. "Party per Pale Azure and Gules, three Lions rampant Argent;" borne by Herbert earl of Pembroke, &c. This noble family is descended from Henry Fitz-Roy, natural son to Henry I. Sir William Herbert, one of the ancestors of the present earl, was master of the horse to King Henry VIII. lord president of the marches of Wales, and knight of the Garter. He was also, by that king, advanced to the dignity of Baron Herbert of Caerdiff, Oct. 10. 1551, and the very next day created earl of Pembroke.—Observe, that if a lion, or any other beast, is represented with its limbs and body separated, so that they remain upon the field at a small distance from their natural places, it is then termed *Dehaché* or *couped in all its parts*; of which very remarkable bearing there is an instance in armory, which is, "Or, a Lion rampant Gules, dehaché, or couped in all its parts, within a double Tressure flowery and counter-flowery of the second;" borne by the name of *Mailand*.

IV. Examples of other Quadrupeds, and their Parts, borne in Coats-of-Arms.

1. "Sable, a Camel statant Argent;" borne by the name of *Camel*.

2. "Gules, an Elephant statant Argent, tusked Or."

3. "Argent, a Boar statant Gules, armed Or;" borne by the name of *Trewarthen*.

4. "Sable, a Bull passant Or;" borne by the name of *Fitz-Geffroy*.

5. "Sable, three Nags Heads erased Argent;" borne by Blayney, Baron Blayney of Monaghan, in Ireland. This noble family is descended in a direct line from Cadwallader, a younger son of the prince of Wales; and the first peer was Sir Edward Blayney, knight, who was created a baron by King James I. July 29. 1621.

6. "Argent, three Boars Heads erased and erect Sable, langued Gules;" for the name of *Booth*.

7. "Azure, three Boars heads erased Or;" quartered by his grace Alexander Gordon duke of Gordon, &c. Of this great and noble family, which took their surname from the barony of Gordon in the county of Berwick, there have been, besides those in North Britain, several of great distinction in Muscovy; and in the time of King Malcolm IV. 1160, this family was very numerous, and flourished in the county aforesaid.

8. "Argent, three Bulls Heads erased, Sable, armed Or;" borne by Skeffington, earl of Massareene, &c. of Ireland. This ancient and noble family derives its name from the village of Skeffington, in the county of Leicesters, of which place Simon Skeffington was lord in the reign of Edward I. and from him descended

VOL. X. Part II.

Sir William Skeffington, knight, made so by King Henry VII.

9. "Argent, two Foxes counter-saliant, the dexter surmounted of the sinister Gules;" for the name of *Kadrod Hard*, an ancient British family, from which is descended Sir _____ Wynne, Bart. who bears this quartered, second and third, in his coat-of-arms.

10. "Argent, three Bulls passant Sable, armed and unguled Or;" for Ashley, and quartered by the right honourable Anthony-Ashley Cooper, earl of Shaftesbury, &c. This noble earl is descended from Richard Cooper, who flourished in the reign of King Hen. VIII. and purchased the manor of Pault in the county of Somerset, of which the family are still proprietors. But his ancestor who makes the greatest figure in history is Sir Anthony-Ashley Cooper, who was created Baron Ashley of Winbourn, April 20. 1661, and afterwards earl of Shaftesbury April 23. 1672.

11. "Ermine, three Cats passant in Pale Argent;" for the name of *Adams*.

12. "Gules, two Grehounds rampant Or, respecting each other;" borne by the name of *Dogget*.

13. "Or, an Ass's Head erased Sable;" borne by the name of *Huckwell*.

14. "Gules, three Lions gambes erased Argent;" for the name of *Newdigate*.

15. "Argent, three Lions Tails erected and erased Gules;" borne by the name of *Cork*.

16. "Azure, a Buck's Head cabossed Argent;" borne by Legge, earl of Dartmouth, &c. This noble family is descended from Signior de Lega, an Italian nobleman, who flourished in Italy in the year 1297. What time the family came into England is uncertain; but it appears they were settled at Legge-place, near Tunbridge in Kent, for many generations; and Thomas, one of their ancestors, was twice lord-mayor of London, viz. in 1346 and 1353.

17. "Argent, two Squirrels sejant adossée Gules;" for the name of *Samwell*.

18. "Gules, a Goat passant Argent;" borne by the name of *Baker*.

19. "Sable, a Stag standing at gaze Argent;" borne by the name of *Jones*, of Monmouthshire.

20. "Azure, three Holy Lambs Or;" borne by the name of *Row*.

V. Examples of Birds, Fishes, Reptiles, &c.

1. "Ermine, an Eagle displayed Sable;" borne by Fig. 17. the name of *Beddingfield*.

2. "Gules, a swan close proper;" borne by the name of *Leigham*.

3. "Argent, a Stork Sable, membered Gules;" borne by the name of *Starkey*.

4. "Gules, a Pelican in her nest with wings elevated, feeding her young ones Or; vulned proper;" borne by the name of *Carne*.

5. "Argent, three Peacocks in their pride proper;" borne by the name of *Pawne*.

6. "Sable, a Goshawk Argent, perching upon a stock in the Base-point of the Escutcheon of the second, armed, jessed, and belled Or;" borne by the name of *Wheele*.

Birds,
Fishes, &c.

Birds,
Fishes, &c.

7. "Or, a Raven proper;" borne by the name of *Corbet*.

8. "Argent, three Cocks Gules, crested and jow-
lipped Sable, a Crescent surmounted of a Crescent for
difference;" borne by Cockayne, Viscount Cullen, of
Donegal in Ireland. Of this ancient family was An-
dreas Cockayne of Ashburne in the county of Derby,
who lived in the 28th year of Edward I. Charles, son
to Sir William Cockayne lord-mayor of London, 1619,
was the first who was advanced to the peerage, by
Charles I. August 11. 1642.

9. "Sable, a Dolphin naiant embowed Or;" borne
by the name of *Symonds*. This animal is borne by the
eldest son of the French king, and next heir to the
crown, no other subject in that kingdom being permit-
ted to bear it. In England, where that rule cannot
take place, there are several families that have dolphins
in their coats-of-arms.

10. "Argent, three Whales Heads erect and erased
Sable;" borne by the name of *Whalley*.

11. "Gules, three Escallops Argent;" borne by
Keppel, earl of Albemarle, &c. This family is de-
scended from Arnold Joost van Keppel, a nobleman of
the province of Guelderland in Holland, who came
over into England with the prince of Orange in 1688,
to whom he was then a page of honour, and afterwards
master of the robes, and was by him created a peer of
England, by the title of earl of Albemarle, in the duchy
of Normandy in France, February 10. 1696.

12. "Azure, three Trouts fretted in Triangle Ar-
gent;" borne by the name of *Troutbeck*.

13. "Vert, a Grasshopper passant Or."

14. "Azure, three Bees two and one volant in pale
Argent;" borne by the name of *Bye*.

15. "Vert, a Tortoise passant Argent;" borne by
the name of *Gawdy*.

16. "Gules, an Adder nowed Or;" borne by the
name of *Nathiley*. Adders, snakes, and serpents, are
said to represent many things, which being according
to the fancy of the ancients, and a few modern authors
who have adopted their opinions, it is needless to en-
large upon. It is certain they often occur in armory:
but the noblest is that of the duchy of Milan, viz.
"Argent, a Serpent gliding in Pale Azure, crowned
Or, vorant an Infant issuing Gules." The occasion of
this bearing was this: Otho, first viscount of Milan,
going to the Holy Land with Godfrey of Bouillon, de-
feated and slew in single combat the great giant Volux,
a man of extraordinary stature and strength, who had
challenged the bravest of the Christian army. The
viscount having killed him, took his armour, and among
it his helmet, the crest whereof was a serpent swallow-
ing an infant, worn by him to strike terror into those
who should be so bold as to engage him.

17. "Ermine, a Rose Gules barbed and seeded pro-
per;" borne by Boscawen Viscount Falmouth, &c.
This family is descended from Richard Boscawen, of
the town of Boscawen, in the county of Cornwall,
who flourished in the reign of King Edward VI. Hugh,
the first peer of this ancient family, was created baron
of Boscawen Rose, and Viscount Falmouth, on the 13th
of June 1720, 6th of George I.

18. "Azure, three Laurel leaves slipped Or;" borne
by the name of *Leveson*, and quartered by the right ho-

nourable Granville-Leveson Gower, earl of Gower, Artificial
&c. Figures.

17. "Azure, three Garbs Or;" borne by the name
of *Cuming*. These are sheaves of wheat; but though
they were barley, rye, or any other corn whatsoever,
it is sufficient, in blazoning, to call them *Garbs*, tell-
ing the tincture they are of.

20. "Gules, three Cinquefoils Argent;" borne by
Lambart, baron of Cavan, &c. in Ireland. Of this
ancient family, which is of French extraction, was Sir
Oliver, who in the reign of Queen Elizabeth, attend-
ing the earl of Essex to Spain, was there knighted by
him, and afterwards returning with that earl into Ire-
land, was, for his singular service in the north against
O'Neal earl of Tyrone, made camp-master-general, and
president of Connsught; and February 17. 1617, was
created Lord Lambart and baron of Cavan by King
James I.

It must be observed, that trees and plants are some-
times said to be trunked, eradicated, fructuated, or ra-
guled, according as they are represented in arms.

ART. 2. Of ARTIFICIAL FIGURES borne in Coats-of- Arms.

After the various productions of nature, artificial fi-
gures, the objects of arts and mechanics, claim the next
rank. They may be distributed into the following clas-
ses, viz.

Warlike instruments; as swords, arrows, battering-
rams, gauntlets, helmets, spears, pole-axes, &c.

Ornaments used in royal and religious ceremonies; as
crowns, coronets, mitres, wreaths, crosiers, &c.

Architecture; as towers, castles, arches, columns,
plumets, battlements, churches, portcullises, &c.

Navigation; as ships, anchors, rudders, pendants, sails,
oars, masts, flags, galleys, lighters, &c.

All these bearings have different epithets, serving ei-
ther to express their position, disposition, or make:
viz. swords are said to be erect, pommeled, hilted, &c.;
arrows, armed, feathered, &c.; towers, covered, em-
battled, &c.; and so on of all others, as will appear
by the following examples.

1. "Sable, three Swords, their points meeting in Fig. 18.
the Base Argent, pommeled and hilted Or, a Crescent
in chief of the second for difference;" borne by Powlet,
duke of Bolton, &c. This noble duke is descended
from Hercules, lord of Tournon in Picardy, who came
over to England with Jeffrey Plantagenet earl of An-
jou, third son of King Henry II. and among other lands
had the lordship of Pawlet in Somersetshire conferred on
him. William Powlet, the first peer of this illustrious
and loyal family, was treasurer of the household to
King Henry VIII. and by him created Baron St John
of Basing, in the county of Southampton, March 9.
1538.

2. "Argent, three Battering-rams barways in Pale,
headed Azure and hooped Or, an Annulet for differ-
ence;" borne by Bertie, earl of Abington, &c. The
first of the family of Bertie that bore the title of earl of
Abington was James Bertie Lord Norris of Rycote,
being created earl, Nov. 30. 1682, by Charles II.

3. "Azure, three left-hand Gauntlets with their
backs forward Or;" borne by Fane, earl of Westmore-
land, &c. This noble earl is descended from the Fanes,
an

Artificial
Figures.

an ancient family which resided at Badsal in Kent, from which descended Francois Fane, son and heir of Sir Thomas Fane, knight, by Mary his wife, sole daughter and heiress to Henry Nevil Lord Abergavenny, afterwards created Baroness Despenser. The said Francis was a knight of the Bath; and in the reign of King James I. was created Baron Burghersh and earl of Westmoreland Dec. 29. 1614.

4. "Azure, three Arrows their points in base Or;" borne by Archer, Lord Archer, &c. This noble lord is descended from John de Archer, who came over from Normandy with William the Conqueror; and this family is one of the most ancient in Warwickshire, being settled at Umberslade in that county ever since the reign of Henry II. His lordship is the first peer; and was created Lord Archer and baron of Umberslade by King George II. July 14. 1747.

5. "Gules, two Helmets in chief proper, garnished Or, in a Base of a Garb of the third;" borne by Cholmondeley, earl of Cholmondeley, &c. This noble earl is descended from the ancient family of Egerton in Cheshire, which flourished in the time of the Conquest, from whom also the duke of Bridgewater was descended. The first English peer of this branch was Hugh Viscount Cholmondeley of Kells, in Ireland, who, joining with those who opposed the arbitrary measures of King James II. was on the accession of King William and Queen Mary created Lord Cholmondeley of Nampwich, in the county of Chester.

6. "Argent, a ship with its sails furled up Sable;" quartered by Hamilton, earl of Abercorn, &c. The descent of this noble family is from that of the duke of Hamilton: for James, the fourth Lord Hamilton and second earl of Arran, marrying Lady Margaret Douglas daughter of James the third earl of Morton, by her had four sons, James, John, Claud, and David: whereof Claud was progenitor of the lord we are now speaking of; and in consideration of his merit and loyalty to Mary queen of Scots, James VI. created him Lord Paisley in 1591, as also earl of Abercorn, baron of Hamilton, &c. July 10. 1606.

7. "Or, an Anchor in pale Gules;" quartered by the most noble George Johnston, marquis of Annandale, &c. The Johnstons are an ancient and warlike family, and derive their surname from the barony of Johnston in Annandale.

8. "Sable, three Spears heads erect Argent, imbrued Gules, on a chief Or, as many Pole-axes Azure;" borne by King, Lord King, &c. Peter King Esq. the first lord of this ancient family, was chosen recorder of the city of London, July 27. 1708, and on the 12th of September following had the honour of knighthood conferred on him. He was constituted lord-chief-justice of the common pleas in the first year of King George I. 1714; on the 5th of April following was sworn of his majesty's most honourable privy-council, and on May 19. 1723 was created a peer of this kingdom by the title of Lord King, baron of Ockham.

9. "Gules, three Clarions Or;" quartered by Carteret, earl of Granville, &c. This ancient family derives its pedigree from Offerey de Carteret, who attended William the Conqueror in his descent upon England, and contributed to the victory he obtained.

over King Harold, at Hastings in Sussex, 1066: he had manors and lands in England conferred on him by that prince, as a reward for his eminent services. George the first earl was, in consideration of his own merit and the services of his ancestors, created a peer of Great Britain, October 19. 1681.

10. "Argent, a Maunch Sable;" borne by Hastings, earl of Huntingdon, &c. This family is descended from Hugh de Hastings, a younger son of the ancient and noble family of the Hastings, earl of Pembroke, of which family was William de Hastings, steward of the household to King Henry I.—William, the first Lord Hastings, was created a baron on July 6. 1461, by King Edward IV.

11. "Azure, a circular Wreath Argent and Sable, with four Hawks Bells joined thereto in quadrature Or;" borne by Jocelyn, Viscount Jocelyn, &c. This noble family is of great antiquity; for, after the Romans had been masters of Britain 500 years, wearied with the wars, they took their final farewell of it, and carried away with them a great many of their brave old British soldiers, who had served them in their wars both at home and abroad, to whom they gave Armorica in France, for their former services, which country was from them afterwards called *Little Britain*. It is supposed that there were some of this family amongst them; and that they gave the name of *Jocelyn* to a town in this country, which still preserves that name; and it is thought probable that they returned with William the Conqueror; for we find, in 1066, mention made of Sir Gilbert Jocelyn. The first lord of the family, was created Baron Newport, of Newport in Ireland, on Nov. 29. 1743, and viscount in Nov. 1751.

11. "Gules, three Towers Argent;" quartered by Fowler, Viscount Ashbrook, &c. William Fowler, Esq. was advanced to the peerage by King George II. and created baron of Castle Durrow in the county of Kilkenny, Oct. 27. 1733; and his son was created Viscount Ashbrook, of Ashbrook in Ireland, on September 30. 1751; now extinct.

13. "Gules, two Keys in Saltier Argent, in Chief a Royal Crown proper;" the arms of the archbishopric of York.

14. "Gules, two Swords in Saltier Argent, pommeled and hilted Or;" the arms of the bishopric of London.

15. "Sable, a Key in Bend, surmounted by a Crosier in Bend-sinister, both Or;" the arms of the bishopric of St Asaph.

16. "Gules, two Keys adossée in Bend, the uppermost Argent, the other Or, a Sword interposed between them in Bend-sinister of the second, pommeled, and hilted of the third;" the arms of the bishopric of Winchester.

17. "Gules, three Mitres with their pendants Or;" the arms of the bishopric of Chester.

18. "Sable, three Ducal Coronets paleways Or;" the arms of the bishopric of Bristol.

19. "Gules, a Sword erect in Pale Argent, pommeled and hilted Or, surmounted by two Keys in Saltier of the last;" the arms of the bishopric of Exeter.

20. "Gules, three Ducal Coronets, Or;" the arms of the bishopric of Ely.

Artificial
Figures.

ART. 3. OF CHIMERICAL FIGURES.

The last and the oddest kind of bearings in coats-of-arms, is comprehended under the name of *chimerical figures*; that is to say, such as have no real existence, but are mere fabulous and fantastical inventions. These charges, griffons, martlets, and unicorns excepted, are so uncommon in British coats, that in order to make up the same number of examples hitherto contained in each collection, several foreign bearings are introduced here; which, however, as they are conform to the laws of heraldry, will also contribute both to entertain and instruct the reader. Those most in use are the following, viz.

Angels, Cherubims, Tritons, Centaurs, Martlets, Griffons, Unicorns, Dragons, Mermaids, Satyrs, Wiverns, Harpies, Cockatrices, Phoenixes.

These, like the foregoing charges, are subject to various positions and dispositions, which, from the principles already laid down, will be plainly understood from the following examples.

Fig. 19.

N^o 1. is "Gules, an Angel standing affrontée, with his hands conjoined and elevated upon his breast, habited in a long Robe close girt Argent, his Wings displayed Or;" borne by the name of *Brangor de Cerevisia*, a foreign prelate, who assisted at the council of Constance, 1412. This example is quoted by Guillim, Sect. III. Chap. I.

2. "Sable, a Chevron between three Cherubim Or;" borne by the name of *Chaloner*, of Yorkshire and Cheshire.

3. "Azure, a Fess indented between three Cherubim Argent." These arms were granted to John Ayde, Esq. of Doddington in Kent, by Sir William Segar, garter.

4. "Gules, a Cherub having three pair of Wings, the uppermost and lowermost counter-crossed Saltierways, and the middlemost displayed Argent;" borne by the name of *Buocasoco*, a foreign prelate. This example is copied from Menestrier's *Methodo du Blason*, p. 120. N^o viii.

5. "Azure, a Griffon segreant Or, armed and langued Gules, between three Crescents Argent;" quartered by Bligh, Lord Clifton, &c. The ancestor of this noble family, who lived in London, going over to Ireland in the time of Oliver Cromwell, as an agent to the adventurers there, acquired a good estate, and laid the foundation for the grandeur of this family.

6. "Gules, three Martlets Or;" borne by the name of Macgill. Guillim observes, that this bird, which is represented without feet, is given for a difference to younger brothers, to put them in mind, that, in order to raise themselves, they are to trust to their wings of virtue and merit, and not to their legs, having but little land to set their feet on.

7. "Azure, three Mulletts Argent within a double Tressure counter-flowerly Or, in the centre a Martlet of the last;" borne by Murray, Lord Elibank. Sir Gideon Murray, knighted by King James VI. by whom he was made treasurer-depute, was third son of Sir Andrew Murray of Blackbarony. His son Patrick, in respect of his loyalty to Charles I. was on May 16. 1628 made a baronet, and in 1643 created Lord Elibank.

8. "Sable, a Cockatrice displayed Argent, crested, membered, and jowlopped Gules." Crown.

9. "Argent, a Mermaid Gules, crined Or, holding in her right hand a Comb, and in her left a Mirror, both proper;" borne by the name of *Ellis*.

10. "Argent, a Wivern, his Wings elevated, and his Tail nowed below him Gules;" borne by the name of *Drakes*.

11. "Or, a Dragon passant Vert."

12. "Gules, a Centaur or Sagittary in full speed regardant proper." This was the coat-of-arms of Stephen surnamed of *Blois*, son to Adela daughter of William the Conqueror, and of Stephen earl of Blois; and on this descent grounding his pretension to the crown of England he was proclaimed king in 1135, and reigned to the 25th of October 1154.

13. "Argent, an Unicorn sejant Sable, unguled and horned Or;" borne by the name of *Harling*.

14. "Argent, a Dragon's Head erased Vert, holding in his Mouth a sinister Hand couped at the Wrist Gules;" borne by the name of *Williams*.

15. "Gules, three Unicorns Heads couped Or;" borne by the name of *Paris*.

16. "Argent, a Wivern volant Bendways Sable;" borne by the name of *Raynon*.

17. "Azure, a Lion Sejant guardant winged Or, his Head encircled with a Glory, holding in his fore-paws an open book, wherein is written, *Pax tibi, Marce, Evangelista meus*; over the dexter side of the Book a Sword erect, all proper." These are the arms of the republic of Venice.

18. "Azure, a Bull saliant and winged Or," borne by the name of *Cadenet*, a family of distinction of Provence.

19. "Argent, a Wivern with a human Face affrontée hooded and winged Vert," borne by the name of *Buseraghi*, an ancient and noble family of Luques.

20. "Azure, a Harpy displayed, armed, crined, and crowned Or." These are the arms of the city of Nuremberg in Germany.

To the fore-mentioned figures may be added the *montegre*, an imaginary creature, supposed to have the body of a tyger with a satyr's head and horns; also those which have a real existence, but are said to be endowed with extravagant and imaginary qualities, viz. the salamander, beaver, camelion, &c.

CHAP. IV. Of the External Ornaments of Escutcheons.

THE ornaments that accompany or surround escutcheons were introduced to denote the birth, dignity, or office, of the persons to whom the coat-of-arms appertaineth; which is practised both among the laity and clergy. Those most in use are of ten sorts, viz. Crowns, Coronets, Mitres, Helmets, Mantlings, Chapeaux, Wreaths, Crests, Scrolls, Supporters.

SECT. I. Of Crowns.

THE first crowns were only diadems, bands, or fillets; afterwards they were composed of branches of divers trees, and then flowers were added to them.

Among

crowns.

Among the Greeks, the crowns given to those who carried the prize at the Isthmian games, were of pine; at the Olympic, of laurel; and at the Nemean, of smallage.

The Romans had various crowns to reward martial exploits and extraordinary services done to the republic; for which see the detached article CROWN in this Dictionary, and Plate CLXIV.

Examples of some of these crowns are frequently met with in modern achievements, viz. 1. The *mural* crown in that of Lord Montfort, which was conferred on Sir John Bromley, one of his lordship's ancestors, as an augmentation to his arms, for his great courage at the battle of Le Crobey. Part of the crest of Lord Archer is also a mural crown. And there are no less than ten English baronets, whose arms are ornamented with the same crown. 2. The *naval* or rostral crown is still used with coats-of-arms, as may be seen in those of Sir William Burnaby, Bart. now admiral of the red squadron, and of John Clerke, Esq. as part of their crests. 3. Of the *castræne* or vallary crown, we have instances in the coats-of-arms of Sir Reginald Graham, and of Isaac Akerman, Esq. 4. The crest of Grice Blackney, Esq. is encompassed with a *civic* crown. 5. The *radiated* crown, according to J. Yorke, was placed over the arms of the kings of England, till the time of Edward III. It is still used as a crest on the arms of some private families; those, for example, borne by the name of *Whitfield*, are ornamented with it. The celestial crown is formed like the radiated, with the addition of a star on each ray; and is only used upon tombstones, monuments, and the like.—Others of the ancient crowns are still borne, as crests, by several families.

But modern crowns are only used as an ornament, which emperors, kings, and independent princes set on their heads, in great solemnities, both to denote their sovereign authority, and to render themselves more awful to their subjects. These are the most in use in heraldry, and are as follows:

The imperial crown (N^o 1.) is made of a circle of gold, adorned with precious stones and pearls, heightened with fleurs-de-lis, bordered and seeded with pearls, raised in the form of a cap voided at the top like a crescent. From the middle of this cap rises an arched fillet enriched with pearls, and surmounted of a mound, whereon is a cross of pearls.

The crown of the kings of Great Britain (2.) is a circle of gold, bordered with ermine, enriched with pearls and precious stones, and heightened up with four crosses patee and four large fleurs-de-lis alternately; from these rise four arched diadems adorned with pearls, which close under a mound, surmounted of a cross like those at bottom. Mr Sandford, in his *Genealogical History*, p. 381. remarks, that Edward IV. is the first king of England that in his seal, or on his coin, is crowned with an arched diadem.

The crown of the kings in France (3.) is a circle enamelled, adorned with precious stones, and heightened up with eight arched diadems, rising from as many fleurs-de-lis, that conjoin at the top under a double fleur-de-lis, all of gold.

The crowns of Spain, Portugal, and Poland, are all three of the same form, and are, amongst others,

thus described by Colonel Parsons, in his *Genealogical Tables of Europe*, viz. A ducal coronet, heightened up with eight arched diadems that support a mound, ensigned with a plain cross. Those of Denmark and Sweden are both of the same form, and consist of eight arched diadems, rising from a marquis's coronet, which conjoin at the top under a mound ensigned with a cross-bottony.

The crowns of most other kings are circles of gold, adorned with precious stones, and heightened up with large trefoils, and closed by four, six, or eight diadems, supporting a mound, surmounted of a cross.

The Great Turk (4.) bears over his arms a turban, enriched with pearls and diamonds, under two coronets, the first of which is made of pyramidal points heightened up with large pearls, and the uppermost is surmounted with crescents.

The Pope, or bishop of Rome, appropriates to himself a Tiara (N^o 5.), or long cap of golden cloth, from which hang two pendants embroidered and fringed at the ends, *semée* of crosses of gold. This cap is enclosed by three marquises coronets; and has on its top a mound of gold, whereon is a cross of the same, which cross is sometimes represented by engravers and painters pometted, recrossed, flowery, or plain.—It is a difficult matter to ascertain the time when the popes assumed the three forementioned coronets. A patched-up succession of the holy pontiffs, engraved and published some years ago by order of Pope Clement XIII. for the edification of his good subjects in Great Britain and Ireland, represents Marcellus, who was chosen bishop of Rome anno 310, and all his successors, adorned with such a cap: but it appears, from very good authority, that Boniface VIII. who was elected into the see of Rome anno 1295, first compassed his cap with a coronet; Benedict XII. in 1335, added a second to it; and John XXIII. in 1411, a third; with a view to indicate by them, that the Pope is the sovereign priest, the supreme judge, and the sole legislator amongst Christians.

SECT. II. Of Coronets.

THE coronet of the prince of Wales, or eldest son of the king of Great Britain (N^o 7.), was anciently a circle of gold set round with four crosses patee, and as many fleurs-de-lis alternately; but since the Restoration, it has been closed with one arch only, adorned with pearls, and surmounted of a mound and cross, and bordered with ermine like the king's.

Besides the aforesaid coronet, his royal highness the prince of Wales has another distinguishing mark of honour, peculiar to himself, called by the vulgar the *prince's arms*, viz. A plume of three ostrich-feathers, with an ancient coronet of a prince of Wales. Under it, in a scroll, is the motto, *Ich Dien*, which in the German or old Saxon language signifies, "I serve;" (see N^o 6.). This device was at first taken by Edward prince of Wales, commonly called the *Black Prince*, after the famous battle of Cressy, in 1346, where having with his own hand killed John king of Bohemia, he took from his head such a plume, and put it on his own.

The coronet of all the immediate sons and brothers of the kings of Great Britain, is a circle of gold, bordered.

Coronets.

p. 20.

Coronets. bordered with ermine, heightened up with four fleurs-de-lis, and as many crosses patee alternate, (see N^o 8.). —The particular and distinguishing form of such coronets as are appropriated to princes of the blood-royal, is described and settled in a grant of Charles II. the 13th of his reign.

The coronet of the princesses of Great Britain is a circle of gold, bordered with ermine, and heightened up with crosses-patee, fleurs-de-lis, and strawberry leaves alternate (N^o 9.); whereas a prince's coronet has only fleurs-de-lis and crosses.

A duke's coronet is a circle of gold bordered with ermine, enriched with precious stones and pearls, and set round with eight large strawberry or parsley leaves; (N^o 10.)

A marquis's coronet is a circle of gold, bordered with ermine, set round with four strawberry leaves, and as many pearls on pyramidal points of equal height, alternate; (N^o 11.).

An earl's coronet is a circle of gold, bordered with ermine, heightened up with eight pyramidal points or rays, on the tops of which are as many large pearls, and are placed alternately, with as many strawberry-leaves, but the pearls much higher than the leaves: (N^o 12.).

A viscount's coronet differs from the preceding ones as being only a circle of gold bordered with ermine, with large pearls set close together on the rim, without any limited number, which is the prerogative above the baron, who is limited: (see N^o 13.).

A baron's coronet, (N^o 14.), which was granted by King Charles II. is formed with six pearls set at equal distances on a gold circle, bordered with ermine, four of which only are seen on engravings, paintings, &c. to show he is inferior to the viscount.

The eldest sons of peers, above the degree of a baron, bear their father's arms and supporters with a label, and use the coronet appertaining to their father's second title; and all the younger sons bear their arms with proper differences, but use no coronets.

As the crown of the king of Great Britain is not quite like that of other potentates, so do most of the coronets of foreign noblemen differ a little from those of the British nobility; as for example, the coronet of a French earl is a circle of gold with 18 pearls set on the brim of it; a French viscount's coronet is a circle of gold only enamelled, charged with four large pearls; and a French baron's coronet is a circle of gold enamelled and bound about with a double bracelet of pearls; and these coronets are only used on French noblemen's coats-of-arms, and not worn on their heads, as the British noblemen and their ladies do at the king's coronation.

SECT. III. Of Mitres.

THE archbishops and bishops of England and Ireland place a mitre over their coats-of-arms. It is a round cap pointed and cleft at the top, from which hang two pendants fringed at both ends; with this difference, that the bishop's mitre is only surrounded with a fillet of gold, set with precious stone, (see fig. 23. N^o 6.), whereas the archbishop's issues out of a ducal coronet, (see fig. 20. N^o 15.).

This ornament, with other masquerade garments, is still worn by all the archbishops and bishops of the church of Rome, whenever they officiate with solemnity; but it is never used in England, otherwise than on coats-of-arms, as before mentioned.

Helmets
and
Mantlings.

SECT. IV. Of Helmets.

THE Helmet was formerly worn as a defensive weapon, to cover the bearer's head, and is now placed over a coat-of-arms as its chief ornament, and the true mark of gentility. There are several sorts, distinguished, 1st, by the matter they are made of; 2dly, by their form; and, 3dly, by their position.

1st, As to the matter they are, or rather were, made of: The helmets of sovereigns were of burnished gold damasked; those of princes and lords, of silver figured with gold; those of knights, of steel adorned with silver, and those of private gentlemen of polished steel.

2dly, As to their form: Those of the king and the royal family, and noblemen of Great Britain, are open-faced and grated, and the number of bars serves to distinguish the bearer's quality; that is, the helmet appropriated to the dukes and marquises is different from the king's, by having a bar exactly in the middle, and two on each side, making but five bars in all, (see fig. 21. N^o 1.); whereas the king's helmet has six bars, viz. three on each side, (ibid. N^o 7.). The other grated helmet with four bars is common to all degrees of peerage under a marquis. The open-faced helmet without bars denotes baronets and knights. The close helmet is for all esquires and gentlemen.

3dly, Their position is also looked upon as a mark of distinction. The grated helmet in front belongs to sovereign princes. The grated helmet in profile is common to all degrees of peerage. The helmet standing direct without bars, and the beaver a little open, denotes baronets and knights. Lastly, the side-standing helmet, with the beaver close, is the way of wearing it amongst esquires and gentlemen. See N^o 1, 2, 3, 4, and 7, inverted in fig. 21. *Ornaments.*

SECT. V. Of Mantlings.

MANTLINGS are pieces of cloth jagged or cut into flowers and leaves, which now-a-days serve as an ornament for escutcheons. They were the ancient coverings of helmets, to preserve them, or the bearer, from the injuries of the weather, as also to prevent the ill consequences of their too much dazzling the eye in action. But Guillim very judiciously observes, that their shape must have undergone a great alteration since they have been out of use, and therefore might more properly be termed *flourishings* than *mantlings*. See the examples annexed to the helmets represented in fig. 21.

The French heralds assure us, that these mantlings were originally no other than short coverings which commanders wore over their helmets, and that, going into battles with them, they often, on their coming away, brought them back in a ragged manner, occasioned by the many cuts they had received on their heads; and therefore the more hacked they were, the more

more

more honourable they were accounted; as our colours in time of war are the more esteemed for having been shot through in many places.

Sometimes skins of beasts, as lions, bears, &c. were thus borne, to make the bearer look more terrible, and that gave occasion to the doubling of mantlings with furs.

SECT. VI. Of Chapeaus.

A CHAPEAU is an ancient hat, or rather cap, of dignity worn by dukes, generally scarlet-coloured velvet on the outside, lined and turned up with fur; of late frequently to be met with above a helmet, instead of a wreath, under gentlemen's and noblemen's crests. Heretofore they were seldom to be found, as of right appertaining to private families; but by the grants of Robert Cooke, Clarencieux, and other succeeding heralds, these, together with ducal coronets, are now frequently to be met with in families, who yet claim not above the degree of gentlemen. See the representation of the chapeau, N^o 5. fig. 21.

SECT. VII. Of Wreaths.

THE Wreath is a kind of roll made of two skeins of silk of different colours twisted together, which ancient knights wore as a head-dress when equipped for tournaments. The colours of the silk are always taken from the principal metal and colour contained in the coat-of-arms of the bearer. They are still accounted as one of the lesser ornaments of escutcheons, and are placed between the helmet and the crest: (see fig. 21. N^o 6.). In the time of Henry I. and long after, no man, who was under the degree of a knight, had his crest set on a wreath; but this, like other prerogatives, has been infringed so far, that every body now a-days wears a wreath.

SECT. VIII. Of Crests.

THE Crest is the highest part of the ornaments of a coat-of-arms. It is called *crest*, from the Latin word *crista*, which signifies comb or tuft, such as many birds have upon their heads, as the peacock, pheasant, &c. in allusion to the place on which it is fixed.

Crests were formerly great marks of honour, because they were only worn by heroes of great valour, or by such as were advanced to some superior military command, in order that they might be the better distinguished in an engagement, and thereby rally their men if dispersed; but they are at present considered as a mere ornament. The crest is frequently a part either of the supporters, or of the charge borne in the escutcheon. Thus the crest of the royal achievement of Great Britain is a "Lion guardant crowned," as may be seen in fig. 21. N^o 7. The crest of France is a double Fleur-de-luce. Out of the many crests borrowed from supporters, are the following, viz. The duke of Montagu's, "A Griffon's head coup'd Or, back'd and wing'd Sable;" the marquis of Rockingham's, "A Griffon's head argent, gorg'd with a ducal coronet;" the earl of Westmoreland's, "A Bull's head Argent, py'd Sable, armed Or;" and Lord Archer's,

which is, "Out of a mural crown Or, a Wyvern's head Argent." There are several instances of crests that are relative to alliances, employments, or names; and which on that account have been changed.

SECT. IX. Of the Scroll.

THE Scroll is the ornament placed above the crest, containing a motto, or short sentence, alluding thereto, or to the bearings; or to the bearer's name, as in the two following instances. The motto of the noble earl of Cholmondeley is, *Cassis tutissima virtus*; i. e. "Virtue is the safest helmet;" on account of the helmet in the coat-of-arms. The motto of the right honourable Lord Fortescue is, *Forto scutum salus ducum*; i. e. "A strong shield is the safety of the commanders;" alluding to the name of that ancient family. Sometimes it has reference to neither, but expresses something divine or heroic; as that of the earl of Scarborough, which is, *Murus arrens conscientia sana*; i. e. "A good conscience is a wall of brass." Others are enigmatical; as that of the royal achievement, which is *Dieu et mon Droit*, i. e. "God and my right;" introduced by Edward III. in 1340, when he assumed the arms and title of *king of France*, and began to prosecute his claim, which occasioned long and bloody wars, fatal by turns to both kingdoms: or that of the prince of Wales, which is *Ich dien*, "I serve," the origin of which has been already mentioned. Mottos, though hereditary in the families that first took them up, have been changed on some particular occasions, and others appropriated in their stead, instances of which are sometimes met with in the history of families.

SECT. X. Of Supporters.

SUPPORTERS are figures standing on the scroll, and placed at the side of the escutcheon; they are so called, because they seem to support or hold up the shield. The rise of supporters is, by F. Menestrier, traced up to ancient tournaments, wherein the knights caused their shields to be carried by servants or pages under the disguise of lions, bears, griffons, blackamoors, &c. who also held and guarded the escutcheons, which the knights were obliged to expose to public view for some time before the lists were opened. Sir George Mackenzie, who dissents from this opinion, says, in his *Treatise on the Science of Heraldry*, chap. xxxi. p. 93. "That the first origin and use of them was from the custom which ever was, and is, of leading such as are invested with any great honour to the prince who confers it: thus, when any man is created a duke, marquis, or knight of the Garter, or any other order, he is supported by, and led to the prince, betwixt two of the quality, and so receives from him the symbols of that honour; and in remembrance of that solemnity, his arms are thereafter supported by any two creatures he chooses." Supporters have formerly been taken from such animals or birds as are borne in the shields, and sometimes they have been chosen as bearing some allusion to the names of those whose arms they are made to support. The supporters of the arms of Great Britain, since King James the First's accession

Supporters. accession to the throne, are a *Lion rampant guardant crowned Or, on the dexter side*, and an *Unicorn Argent, crowned, armed, unguled, maned and gorged with an antique Crown, to which a chain is affixed, all Or, on the sinister*; as it appears by fig. 21. N^o 7.

This last figure represents the coat-of-arms of the king of Great Britain, or the royal achievement, as it has been marshalled since the accession of King George I. in 1714, and is blazoned as follows, viz.

ARMS. *Quarterly, in the first grand quarter Gules, three Lions rampant guardant in pale Or, the imperial ensigns of England; impaled with Or, a Lion rampant, with a double tressure flowery and counter-flowery Gules, the royal arms of Scotland. The second is Azure, three Fleurs-de-lis Or, the arms of France. The third is Azure, a Harp Or, stringed Argent, the ensign of Ireland. The fourth grand quarter is Gules, two Lions passant guardant in pale Or, for Brunswick; impaled with Or semée of Hearts Proper, a Lion rampant Azure, for Lunenburg; with grafted in base Gules a Horse current Argent, for ancient Saxony; and in a shield surtout Gules, the Crown of Charlemagne Or, as arch-treasurer of the empire; the whole within a Garter, inscribed with this motto, HONI SOIT QUI MAL Y PENSE, as sovereign of that noble order, given by the founder King Edward III.*

CREST. *On a Helmet full-faced, grated and surmounted of a Crown, a Lion guardant crowned Or; the mantlings of the last, and lining, Ermine.*

SUPPORTERS. *On the Dexter side a Lion rampant guardant Or, crowned as the Crest. On the Sinister side an Unicorn Argent, crowned, armed, maned, and unguled Or, gorged with an antique Crown; a Chain affixed thereto, reflecting over the back, and passing over the hind legs of the last, both standing on a Scroll inscribed with this motto, DIEU ET MON DROIT, from which issue the two Royal Badges of his Majesty's chief Dominions, viz. on the Dexter side a Rose party per Pale Argent and Gules, stalked and leaved proper, for England; and on the Sinister side a Thistle proper, for Scotland; being so adorned by King James I. upon his succeeding to the crown of England. As king of Scotland, he bore two unicorns, as above, for his supporters; but upon the union of that kingdom with England, 1603, he introduced one of the above supporters on the sinister side of the royal achievement, and which continues to this day.*

It is to be observed, that bearing coats-of-arms supported, is, according to the heraldical rules of England, the prerogative, 1st, Of those called *nobiles majores*, viz. dukes, marquises, earls, viscounts, and barons; 2d, Of all knights of the Garter, though they should be under the degree of barons; 3d, Of knights of the Bath, who both receive on their creation a grant of supporters. And, lastly, of such grants as the king chooses to bestow this honour upon; as in the instance of Sir Andrew Fountain, who was knighted by Philip earl of Pembroke, when lord lieutenant of Ireland, Fountain being then his secretary; and on his return to England, King William granted him supporters to his arms, viz. *two Griffins Gules and Or*. In Scotland, all the chiefs of clans or names have the privilege of claiming supporters; also the baronets. But by act of parliament, 10th September

1672, none are allowed to use either arms or supporters, under a penalty and confiscation of all moveables whereon arms are put, without the Lord Lyon's authority. Rates of Heraldry.

CHAP V. Of the Rules or Laws of Heraldry.

THE several escutcheons, tinctures, charges, and ornaments of coats-of-arms, and their various properties, being now explained; it may not be improper to subjoin such rules for blazoning the same, as the ancient usage and laws of heraldry have established amongst us.

I. The *first* and most general rule is, to express one's self in proper terms, so as not to omit any thing that ought to be specified, and at the same time to be clear and concise without tautology; as in Ex. xiv. Chap. III. art. 1. and also in Ex. 11. art. 7. wherein these expressions of *the Field*, or of *the First*, prevent the repetition of the forementioned tincture.

II. One must begin with the tincture of the field, and then proceed to the principal charges which possess the most honourable place in the shield, such as Fess, Cheveron, &c. always naming that charge first which lies next and immediately upon the field; as in Ex. 15. Chap. III. art. 5.

III. After naming the tincture of the field, the honourable ordinaries, or other principal figures, you must specify their attributes, and afterwards their metal or colour, as in Ex. 16. *Examples of Effigies, &c.*

IV. When an honourable ordinary, or some one figure, is placed upon another, whether it be a Fess, Cheveron, Cross, &c. it is always to be named after the ordinary or figure over which it is placed, with one of these expressions, *sur tout*, or *over all*, as in Ex. 20. Chap. III. art. 1.

V. In the blazoning of such ordinaries as are plain, the bare mention of them is sufficient; but if an ordinary should be made of any of the crooked lines mentioned above, its form must be specified; that is, whether it be Engrailed, Wavy, &c. as in Ex. 1. 2. 3. Chap. III. art. 1.

VI. When a principal figure possesses the centre of the field, its position is not to be expressed: or (which amounts to the same thing) when a bearing is named, without specifying the point where it is placed, then it is understood to possess the middle of the shield; as in Ex. 15. *Examples of other Quadrupeds, &c.*

VII. The number of the points of mullets or stars must be specified when more than five; and also if a mullet or any other charge be pierced, it must be mentioned as such, to distinguish it from what is plain; as in Ex. 13. 14. *Examples of Celestial Figures.*

VIII. When a ray of the sun, or other single figure, is borne in any other part of the escutcheon than the centre, the point it issues from must be named; as in Ex. 3. *Examples of Celestial Figures.*

IX. The natural colour of trees, plants, fruits, birds, &c. is no otherwise to be expressed in blazoning but by the word *proper*, as in Ex. 2. 7. *Examples of Birds, &c.*; but if discoloured, that is, if they differ from their natural colour, it must be particularized; as in Ex. 1. 2. *Examples of other Quadrupeds, &c.*

X. When three figures are in a field, and their position

Marshall-
ling.

Marshall-
ling.

sition is not mentioned in the blazoning, they are always understood to be placed, two above, and one below; as in fig. 23. N^o 3.

XI. When there are many figures of the same species borne in a coat-of-arms, their number must be observed as they stand, and distinctly expressed; as in Ex. 1. *Of Artificial Figures, &c.*

But for the better understanding of this last rule, we have inserted examples of the *different dispositions of figures*, wherein they are properly represented, viz.

Two may be ranged in Pale, in Fess, &c. See fig. 22. N^o 1 and 2.

Three may be 2 and 1, as also in Bend, &c. See N^o 3 and 4.

Four, are placed 2 and 2, or cantoned, as in N^o 5.

Five, 1, 3, 1, in Cross; or 2, 1, 2, in Saltier. See N^o 6 and 7.

Six, 3, 2, 1, in Pile; or 2, 2, 2, Paleways. See N^o 8 and 9.

Eight, in Orle, or on a Bordure. See N^o 10.

Nine, 3, 3, 3, Barways; or 3, 3, 2, 1, in Pile. See N^o 11 and 12.

Ten, 4, 3, 2, 1, in Pile; or else, 4, 2, 4, Barways. See N^o 13 and 14.

Twelve, are placed 4, 4, 4, Barways. See N^o 15.

There are other positions called *irregular*; as for example, when three figures which are naturally placed 2 and 1, are disposed 1 and 2, &c. It must also be observed, that when the field is strewed with the same figures, this is expressed by the word *semée*: but, according to a French armorist's opinion, if the figures strewed on the field are whole ones, it must be denoted by the words *sans nombre*; whereas, if part of them is out off at the extremities of the escutcheon, the word *semée* or *semi* is then to be used.

CHAP. VI. *Of Marshalling Coats-of-arms.*

By *marshalling* coats-of-arms, is to be understood the art of disposing divers of them in one escutcheon, and of distributing their contingent ornaments in proper places.

Various causes may occasion arms to be thus conjoined, which J. Guillim comprises under two heads, viz. *manifest* and *obscure*.

What this learned and judicious herald means by *manifest causes* in the marshalling of coats-of-arms, are such as betoken marriages, or a sovereign's gift, granted either through the special favour of the prince, or for some eminent services. Concerning marriages it is to be observed,

I. When the coats-of-arms of a married couple, descended of distinct families, are to be put together in one escutcheon, the field of their respective arms is conjoined Paleways, and blazoned *parted per pale, Baron and Femme, two coats; first, &c.* In which case the baron's arms are always to be placed on the dexter side, and the femme's arms on the sinister side, as in N^o 1 and 2, fig. 23. *Of arms marshalled*, which are,

1. The coat-of-arms of the Rev. Edward Barnard, D. D. chaplain in ordinary to his majesty, provost of Eton-college, canon of Windsor, &c. impaled with that of S. Hagatt, his spouse.

2. The coat-of-arms of the Rev. Thomas Dampier, Vol. X. Part II. †

D. D. chaplain in ordinary to his majesty, prebendary of Durham, canon of Windsor, &c. impaled with that of F. Walker, his spouse.

If a widower marry again, his late and present wife's arms are, according to G. Leigh, "to be both placed on the sinister side in the escutcheon with his own, and parted per Pale. The first wife's coat shall stand on the Chief, and the second on the Base; or he may set them both in Pale with his own, the first wife's coat next to himself, and his second outermost. If he should marry a third wife, then the two first matches shall stand on the Chief, and the third shall have the whole Base. And if he take a fourth wife, she must participate one half of the Base with the third wife, and so will they seem to be so many coats quartered." But it must be observed, that these forms of impaling are meant of hereditary coats, whereby the husband stands in expectation of having the hereditary possessions of his wife united to his patrimony.

II. In the arms of femmes joined to the paternal coat of the baron, the proper differences by which they were borne by the fathers of such women must be inserted.

III. If a coat-of-arms that has a Bordure be impaled with another, as by marriage, then the Bordure must be wholly omitted in the side of the arms next the centre.

IV. The person that marries an heiress, instead of impaling his arms with those of his wife, is to bear them in an escutcheon placed in the centre of his shield, after the same manner as the baronet's badge is marshalled in N^o 3. and which, on account of its showing forth his pretension to her estate, is called an *escutcheon of pretence*, and is blazoned *surtout*, i. e. *over-all*, as in the escutcheon borne in the fourth quarter of the royal achievement. But the children are to bear the hereditary coat-of-arms of their father and mother *quarterly*, which denotes a fixed inheritance, and to transmit them to posterity. The first and fourth quarters generally contain the father's arms, and the second and third the mother's; except the heirs should derive not only their estate, but also their title and dignity, from their mother.

V. If a maiden or dowager lady of quality marry a commoner, or a nobleman inferior to her rank, their coats-of-arms may be set aside of one another in two separate escutcheons, upon one mantle or drapery, and the lady's arms ornamented according to her title; see N^o 4. and 6. which represent the coats-of-arms of Gen. C. Montagu, and Lady Elizabeth Villiers Viscountess Grandison.

VI. Archbishops and bishops impale the arms differently from the fore-mentioned coats, in giving the place of honour, that is, the dexter side, to the arms of their dignity, as it is expressed in N^o 6. which represents the coat-of-arms of Dr Philip Yonge, Lord bishop of Norwich. It may be observed of the above prelates, that they thus bear their arms parted per Pale, to denote their being joined to their cathedral church in a sort of spiritual marriage.

With respect to such armorial ensigns as the sovereign thinks fit to augment a coat-of-arms with, they may be marshalled various ways, as may be seen by the arms of his grace the duke of Rutland, inserted in

Of Escutcheons.

fig. 8. N^o 19. and the example contained in fig. 11. N^o 11.

To those augmentations may be added, 1st, The baronet's mark of distinction, or the arms of the province of Ulster in Ireland, granted and made hereditary in the male line by King James I. who erected this dignity on the 22d of May 1611, in the 9th year of his reign, in order to propagate a plantation in the fore-mentioned province. This mark is *Argent, a sinister Hand couped at the Wrist, and erected Gules*; which may be borne either in a canton, or in an escutcheon, as will best suit the figures of the arms. See fig. 23. N^o 3. which represents the coat-of-arms of Sir William Lorraine, of Kirk-barle, Northumberland, and are thus blazoned: *Quarterly, Sable and Argent, a plain Cross counter-quartered of the Field.* The Crest,—*A Laurel-tree couped, two branches sprouting out proper, and fixed to the lower part thereof with a Belt Gules, edged and buckled Or.* This, according to tradition in the family, was granted for some worthy action in the field.

2dly, The ancient and respectable badge of the most noble order of the Garter, instituted by King Edward III. 1349, in the 27th year of his reign; and which, ever since its institution, has been looked upon as a great honour bestowed on the noblest persons of this nation and other countries. This honourable augmentation is made to surround, as with a garter, the arms of such knights, and is inscribed with this motto, *Honi soit qui mal y pense*: see N^o 7. which represents the coat-of-arms of his grace the duke of Montagu, earl of Cardigan, Baron Brudenel of Stanton-Wevil, constable and lieutenant of Windsor-castle, knight of the most noble order of the Garter, and baronet, president of St Luke's Hospital, and F. R. S.

This nobleman, whose arms were *Argent, a Chevron Gules between three Morions proper*, has, since the decease of John duke of Montagu, taken the name and arms of *Montagu*, on account of his being married to Lady Mary Montagu, youngest daughter, and one of the co-heiresses of his grace.

So far the causes for marshalling divers arms in one shield, &c. are manifest. As to such as are called *obscure*, that is, when coats-of-arms are marshalled in such a manner, that no probable reason can be given why they are so conjoined, they must be left to heralds to explain, as being the properest persons to unfold these and other mysteries of this science.

CHAP. VII. Of Funeral Escutcheons.

AFTER having treated of the essential parts of the coats-of-arms, of the various charges and ornaments usually borne therewith, of their attributes and dispositions, and of the rules for blazoning and marshalling them, we shall next describe the several funeral escutcheons, usually called *hatchments*; whereby may be known, after any person's decease, what rank either he or she held when living; and if it be a gentleman's hatchment, whether he was a bachelor, married man, or widower, with the like distinctions for gentlewomen.

Plate
CC LX.

The hatchment, fig. 24. N^o 1. represents such as are affixed to the fronts of houses, when any of the nobility

and gentry dies; the arms therein being those of a private gentleman and his wife parted per pale; the dexter side, which is *Gules*, three Bars *Or*, for the husband; having the ground without the escutcheon black, denotes the man to be dead; and the ground on the sinister side being white, signifies that the wife is living, which is also demonstrated by the small hatchment, N^o 2. which is here depicted without mantling, helmet, and crest, for perspicuity's sake only.

When a married gentlewoman dies first, the hatchment is distinguished by a contrary colour from the former; that is, the arms on the sinister side have the ground without the escutcheon black; whereas those on the dexter side, for her surviving husband, are upon a white ground: the hatchment of a gentlewoman is, moreover, differenced by a cherub over the arms instead of a crest. See N^o 3.

When a bachelor dies, his arms may be depicted single or quartered, with a crest over them, but never impaled as the two first are, and all the ground without the escutcheon is also black. See N^o 4.

When a maid dies, her arms, which are placed in a lozenge, may be single or quartered, as those of a bachelor; but, instead of a crest, have a cherub over them, and all the ground without the escutcheon is also black. See N^o 5.

When a widower dies, his arms are represented impaled with those of his deceased wife, having a helmet, mantling, and crest over them, and all the ground without the escutcheon black. See N^o 6.

When a widow dies, her arms are also represented impaled with those of her deceased husband, but enclosed in a lozenge, and, instead of a crest, a cherub is placed over them; all the ground without the escutcheon is also black. See N^o 7.

If a widower or bachelor should happen to be the last of his family, the hatchment is depicted as in N^o 6. and that of a maid or widow, whose family is extinct by her death, is depicted as in N^o 7. with this difference only, that a death-head is generally annexed to each hatchment, to denote, that death has conquered all.

By the fore-mentioned rules, which are sometimes neglected through the ignorance of illiterate people, may be known, upon the sight of any hatchment, what branch of the family is dead; and by the helmet or coronet, what title and degree the deceased person was of.

The same rules are observed with respect to the escutcheon placed on the hearse and horses used in pompous funerals, except that they are not surmounted with any crest, as in the foregoing examples of hatchments, but are always plain. It is necessary, however, to assign those of peers with coronets, and that of a maiden lady with a knot of ribbands.

In *Scotland*, a funeral escutcheon not only shows forth the arms and condition of the defunct, but is also a proof of the gentility of his descent; and such persons for whom this species of escutcheon can be made out, are legally entitled to the character of gentlemen of blood, which is the highest species of gentility. The English hatchment above described exhibits no more than a right to a coat-of-arms which may be acquired by purchase, and is only the first step towards establishing gentility in a family.

Of Escutcheons.

Fig. A.

LINES, DIFFERENCES &c.

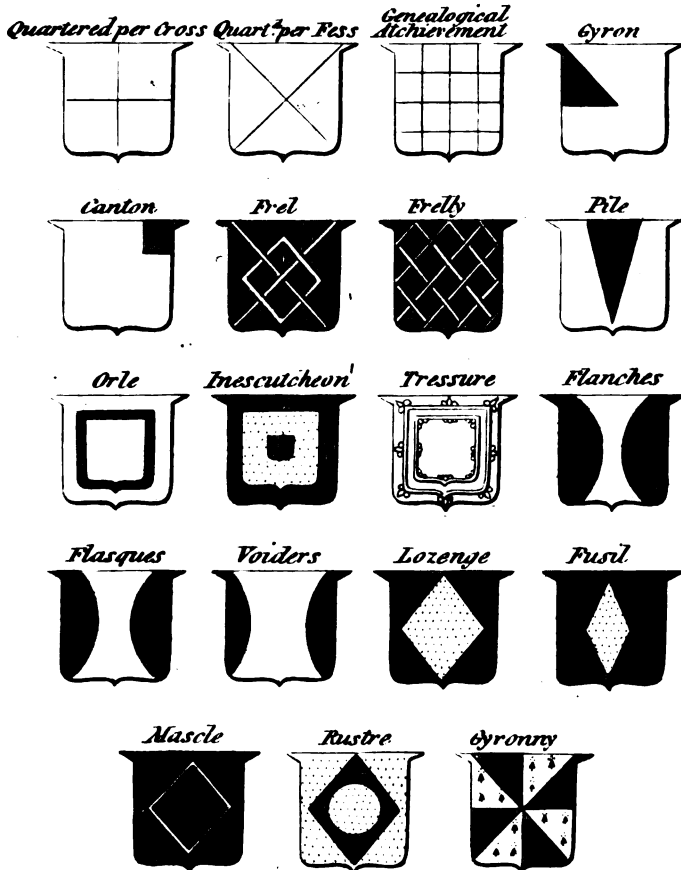
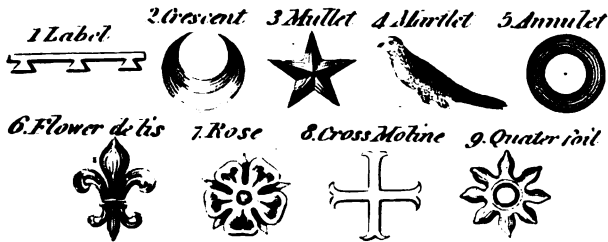
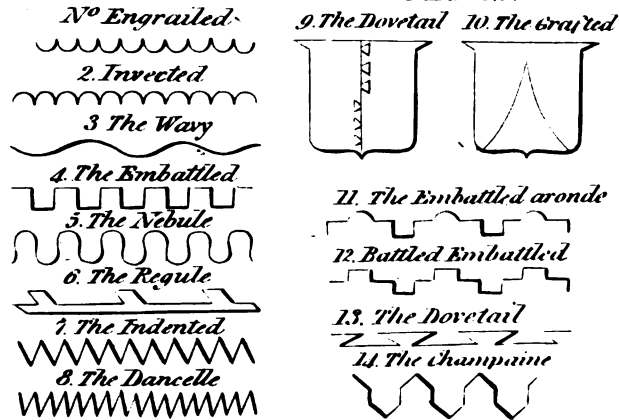
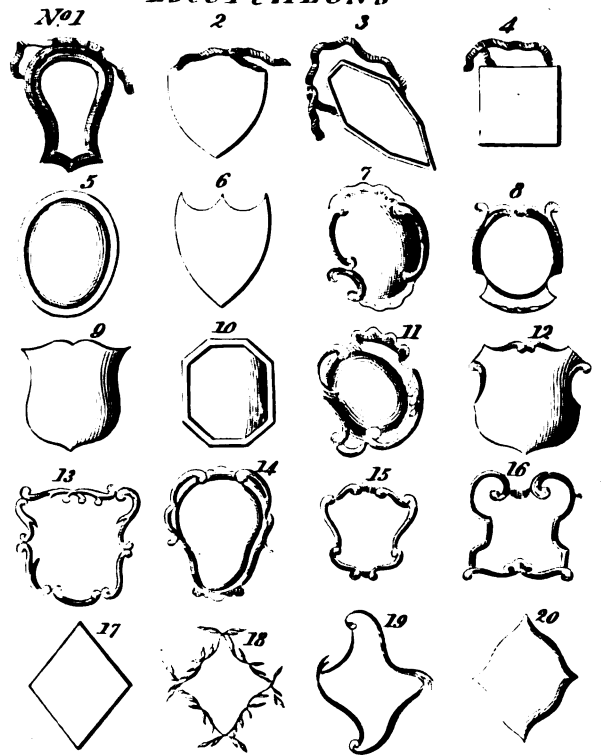
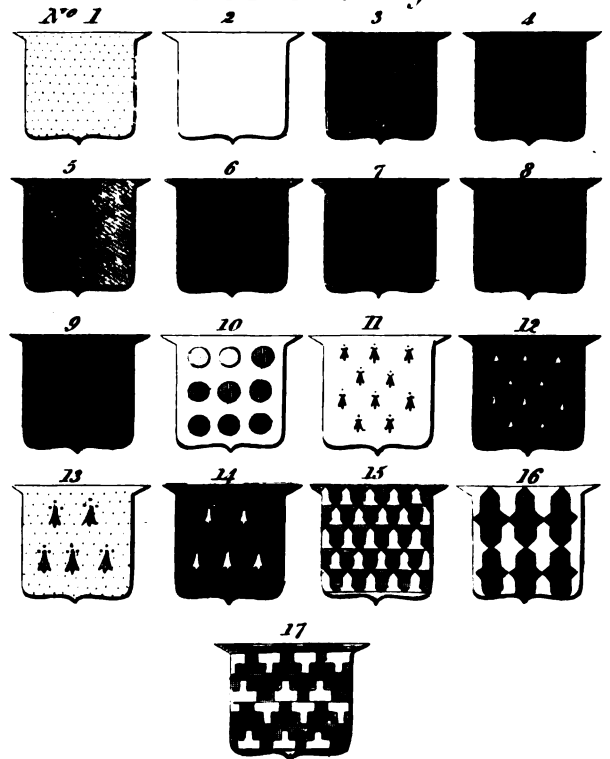

Fig. B
ESCUTCHEONS



TINCTURES Fig. 2



BORDURES Fig. 3.

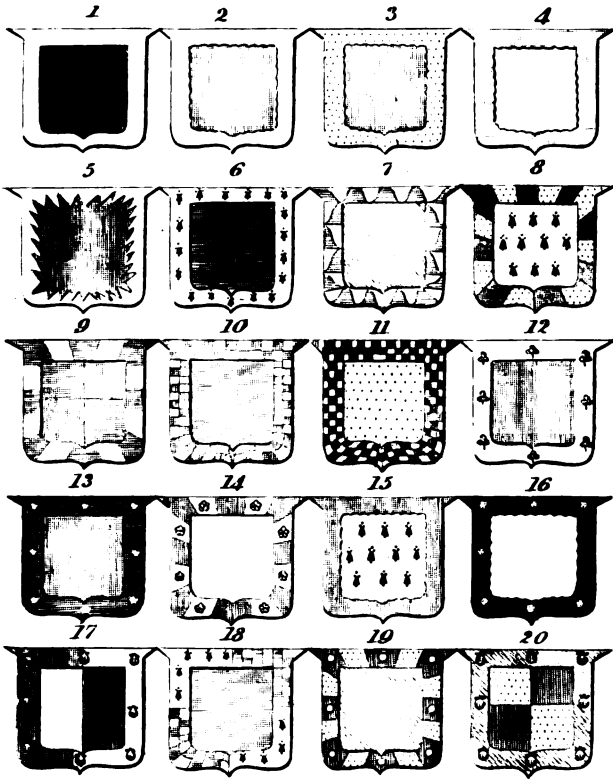

CHIEFS &c. Fig. 5.

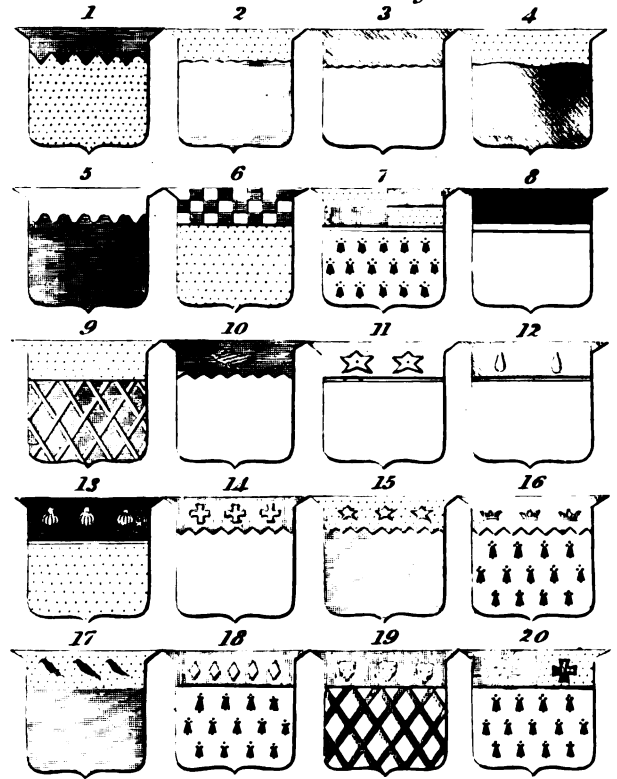
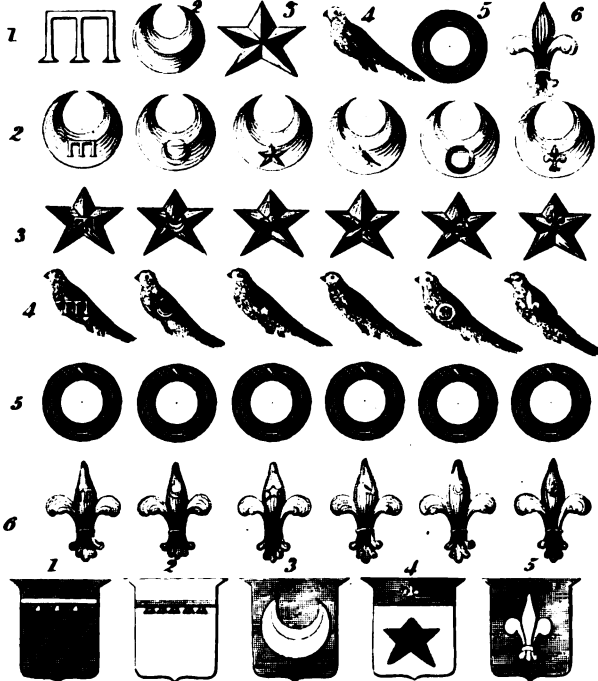
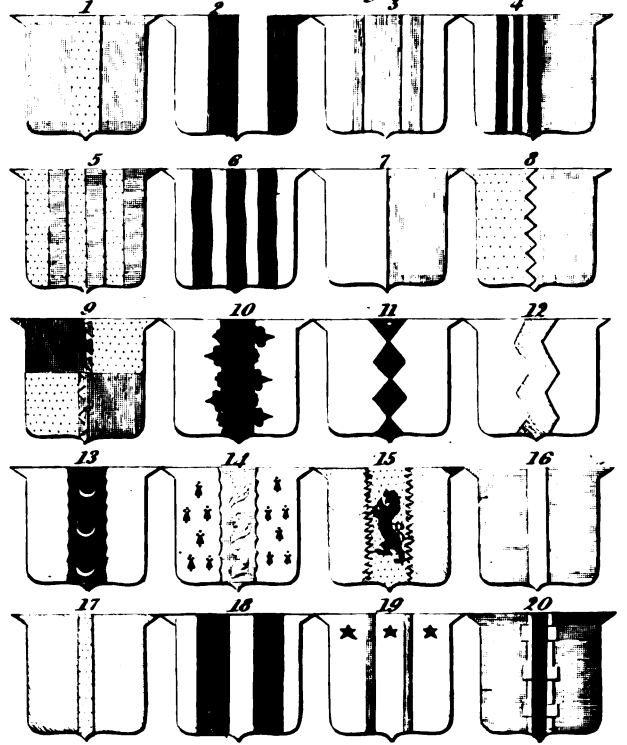

TABLE OF HOUSES Fig. 4.



PALES &c. Fig. 6.



T. Clark Sculp^r

BENDS Fig. 7

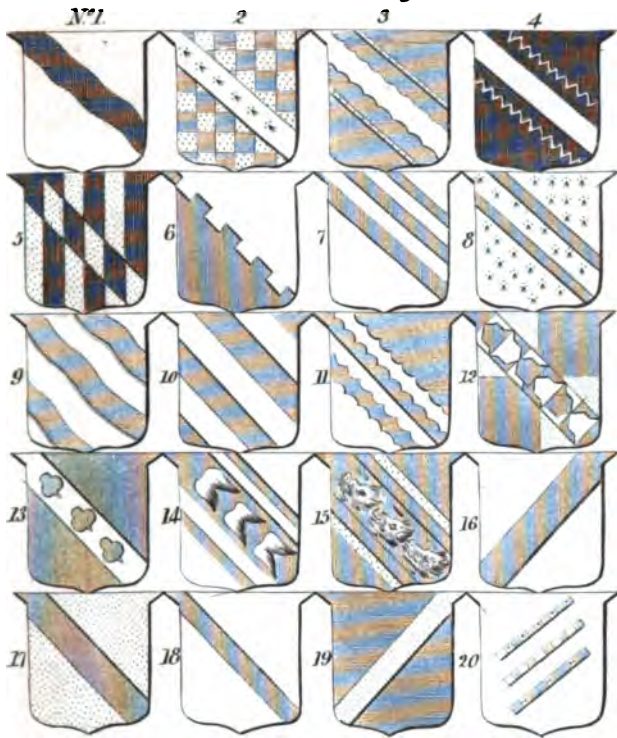

FESSES & BARS Fig. 8.

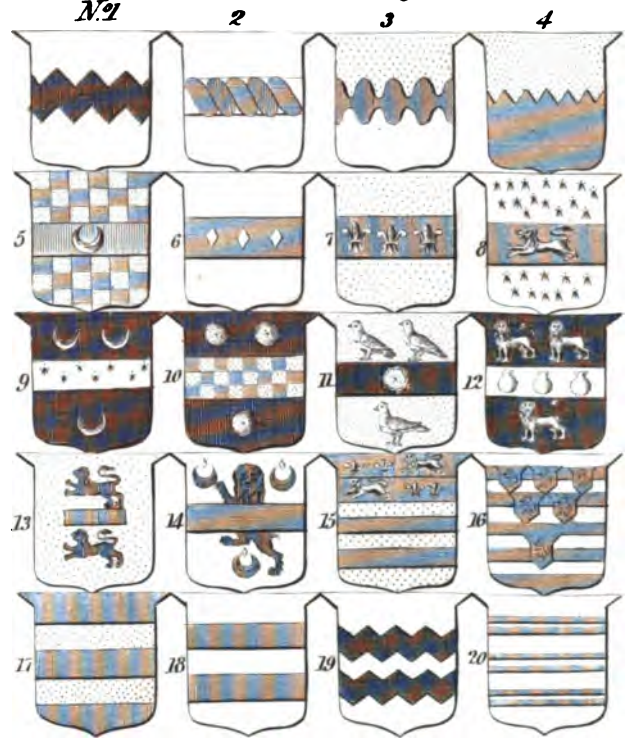

CHEVERON &c. Fig. 9.

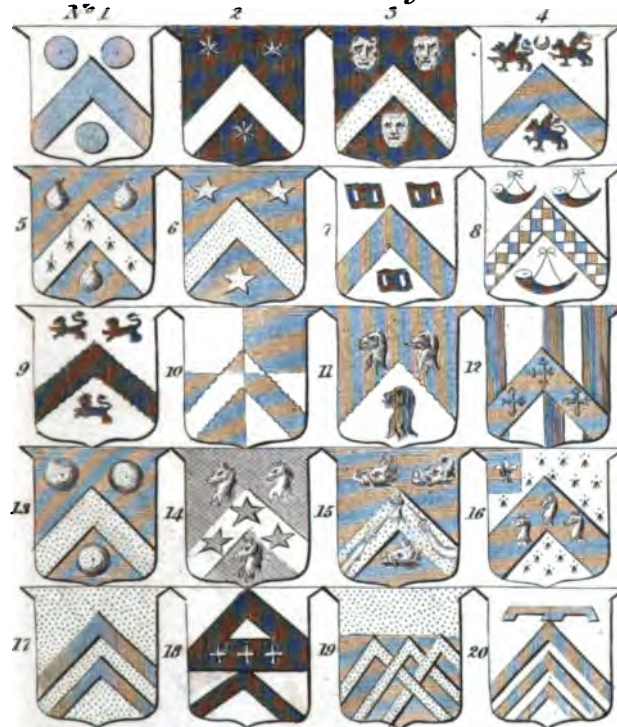

CROSSES Fig. 10.

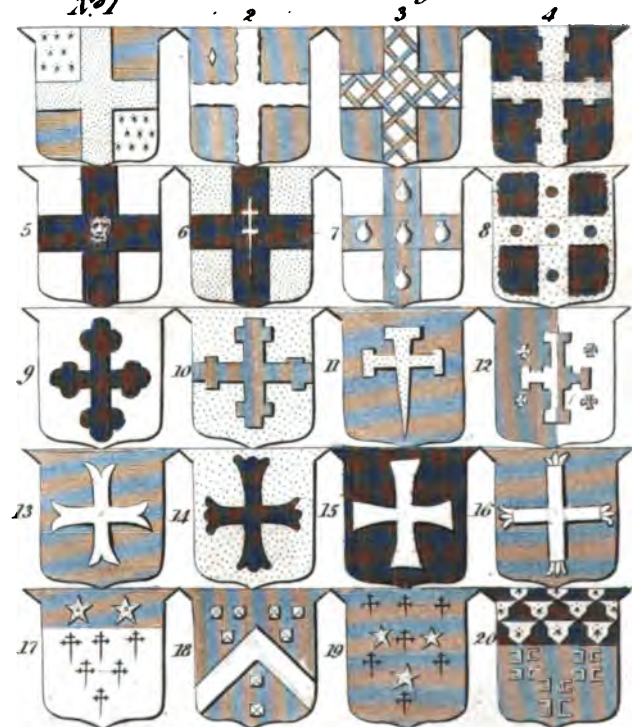

SALTIER. Fig. 11.

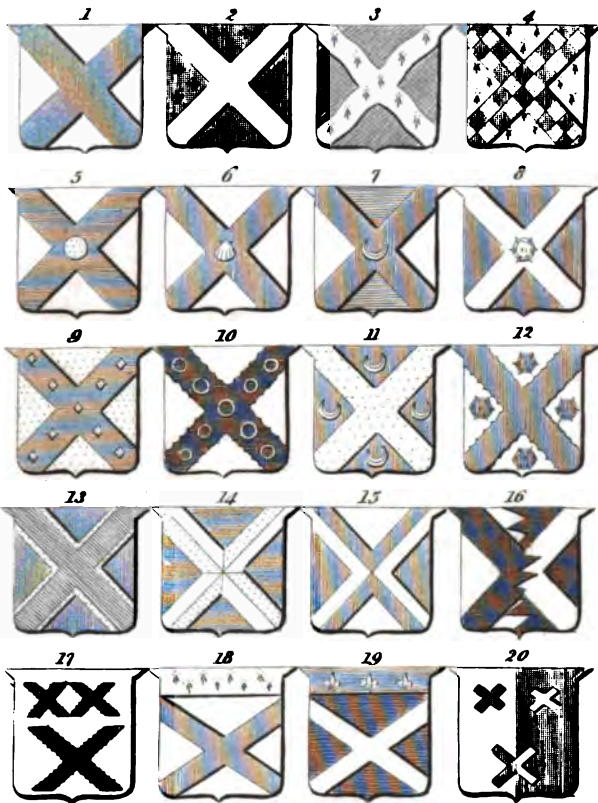

CELESTIALS Fig. 13.

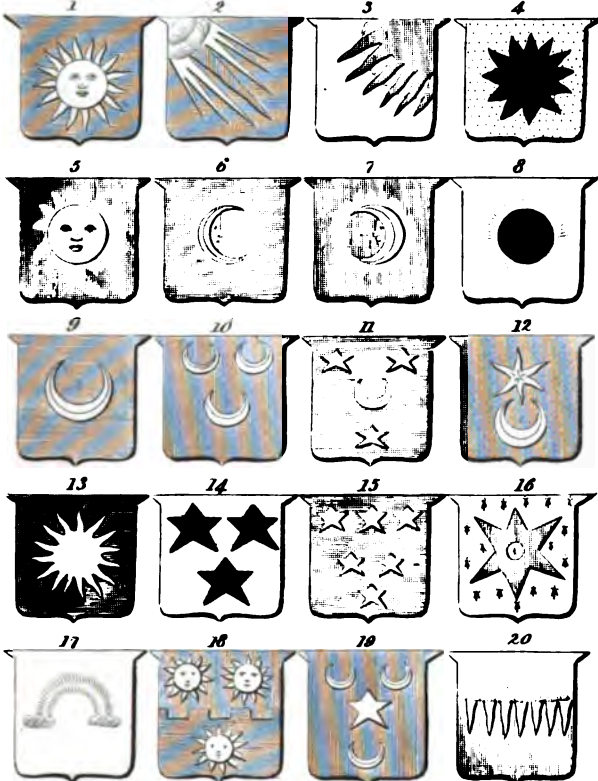

ORDINARIES &c. Fig. 12.

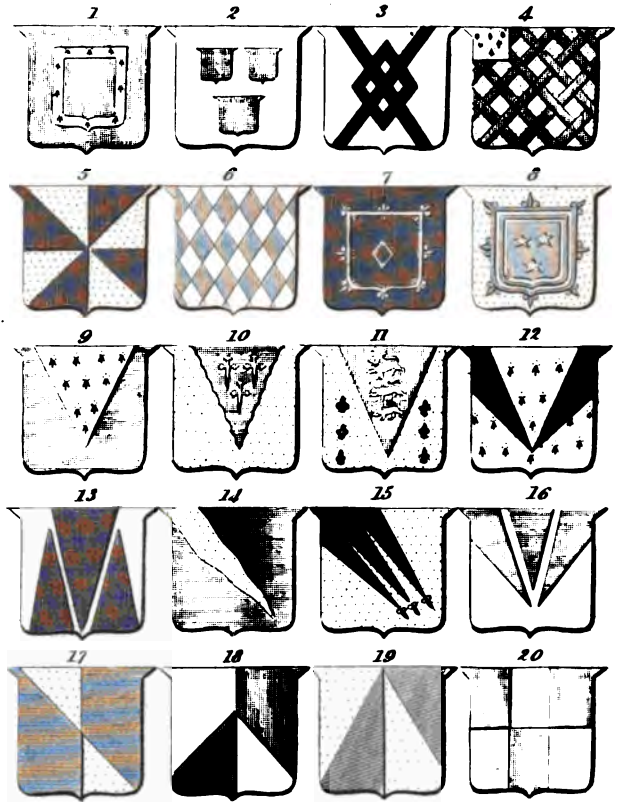

EFFIGIES, &c. Fig. 14.

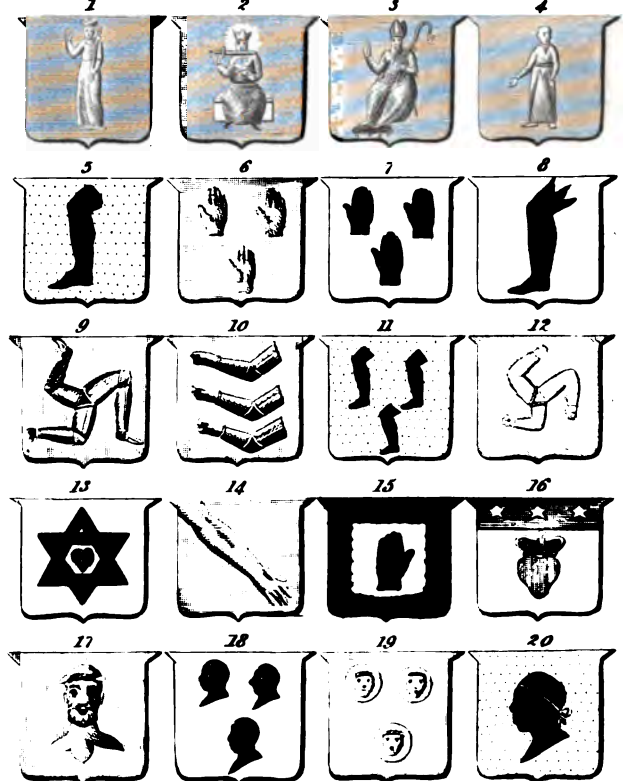

LIONS &c Fig. 15.

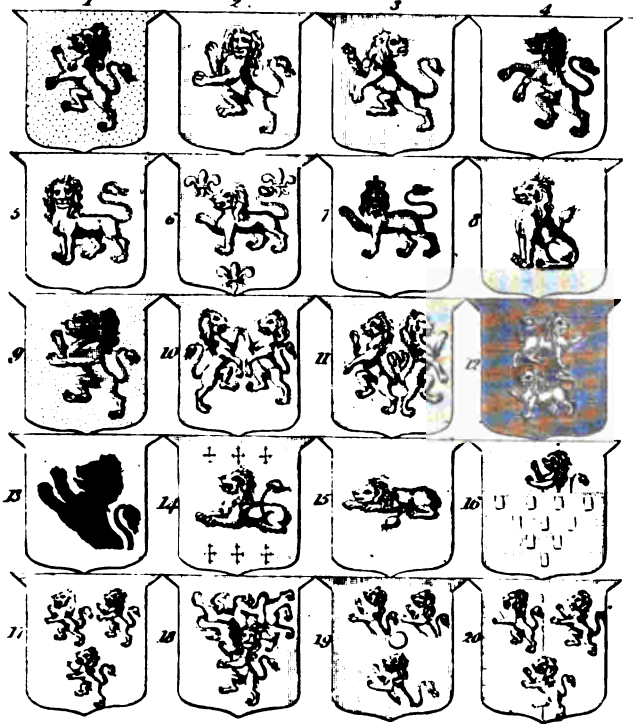

ANIMALS &c Fig. 16.

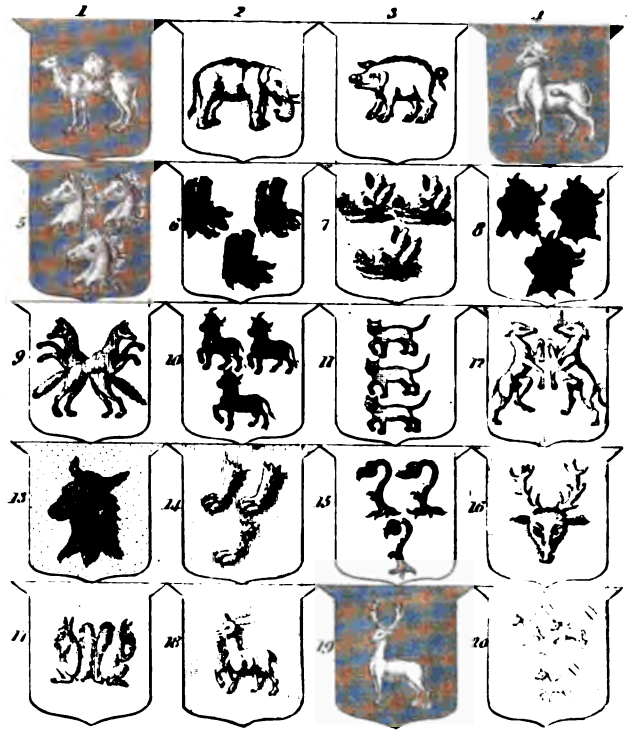

BIRDS &c Fig. 17.



ARTIFICIAL FIGURES Fig. 18.

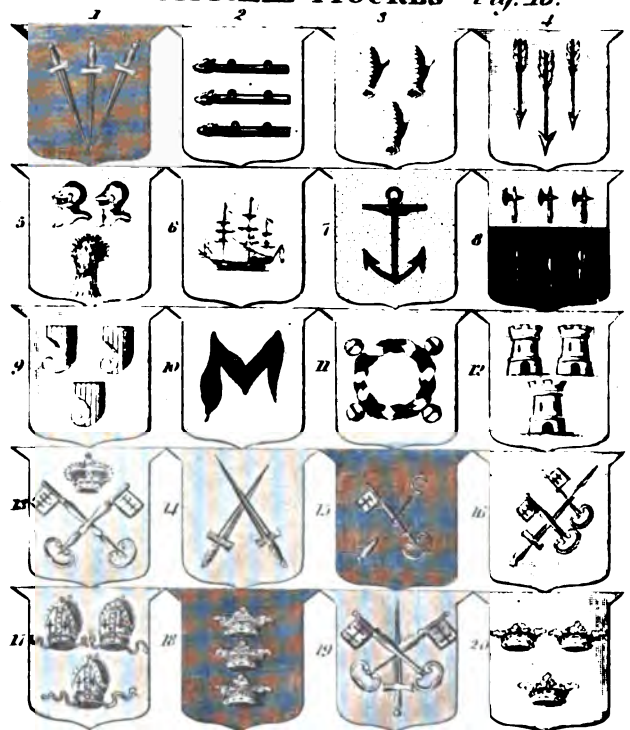

Wark Sculp.

CHIMERICAL FIGURES *Fig. 19.*



CROWNS *Fig. 20.*

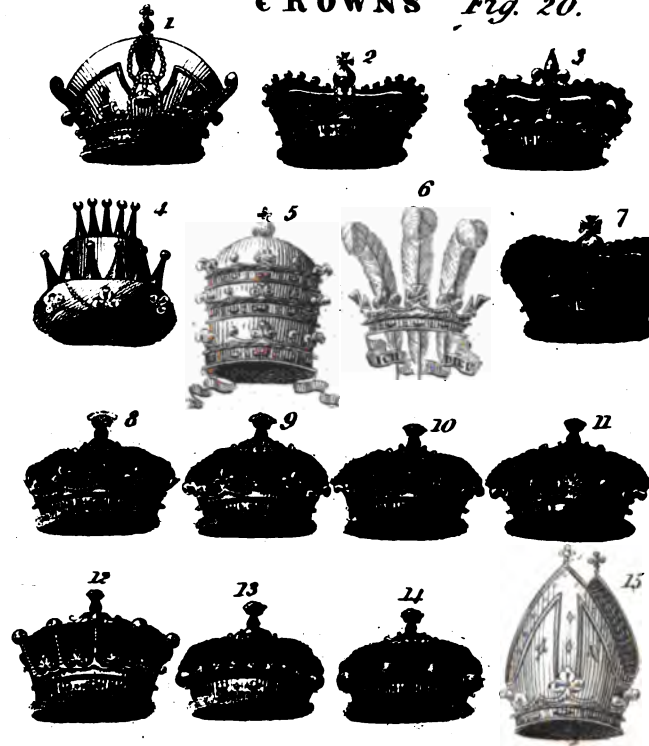

ORNAMENTS *Fig. 21.*



DISPOSITIONS. *Fig. 22.*

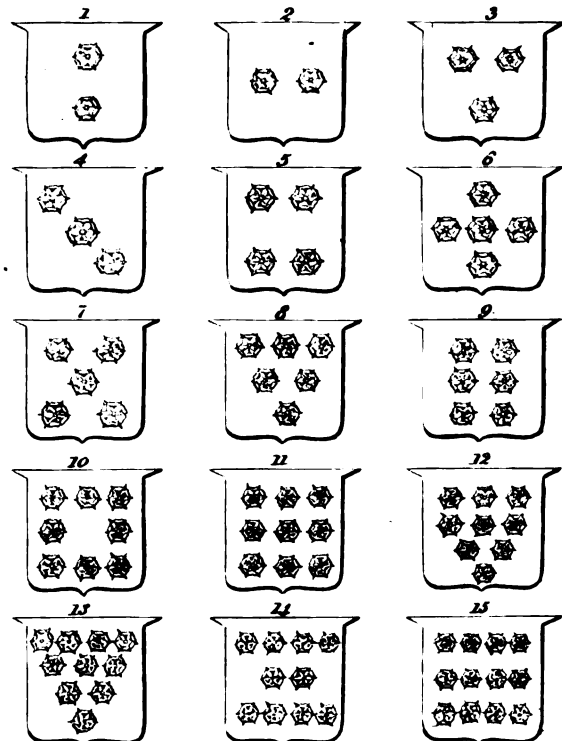

FLAGS



Royal Arms of Britain
Settled Nov. 1800.

HERALDRY

Fig. 23 Arms Marshallled

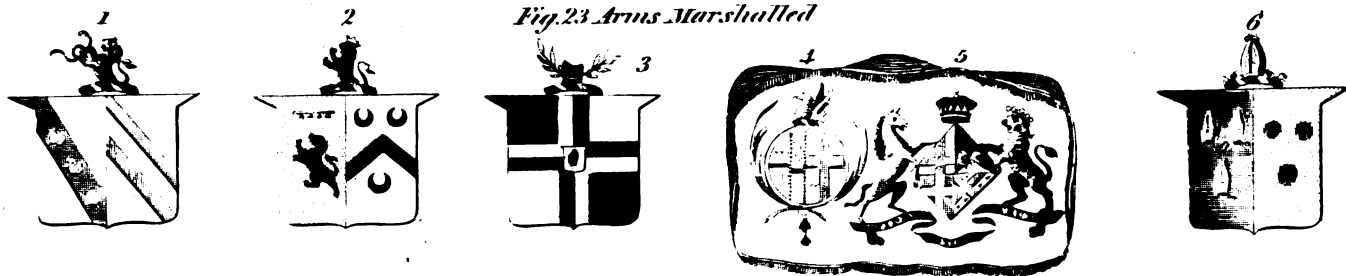
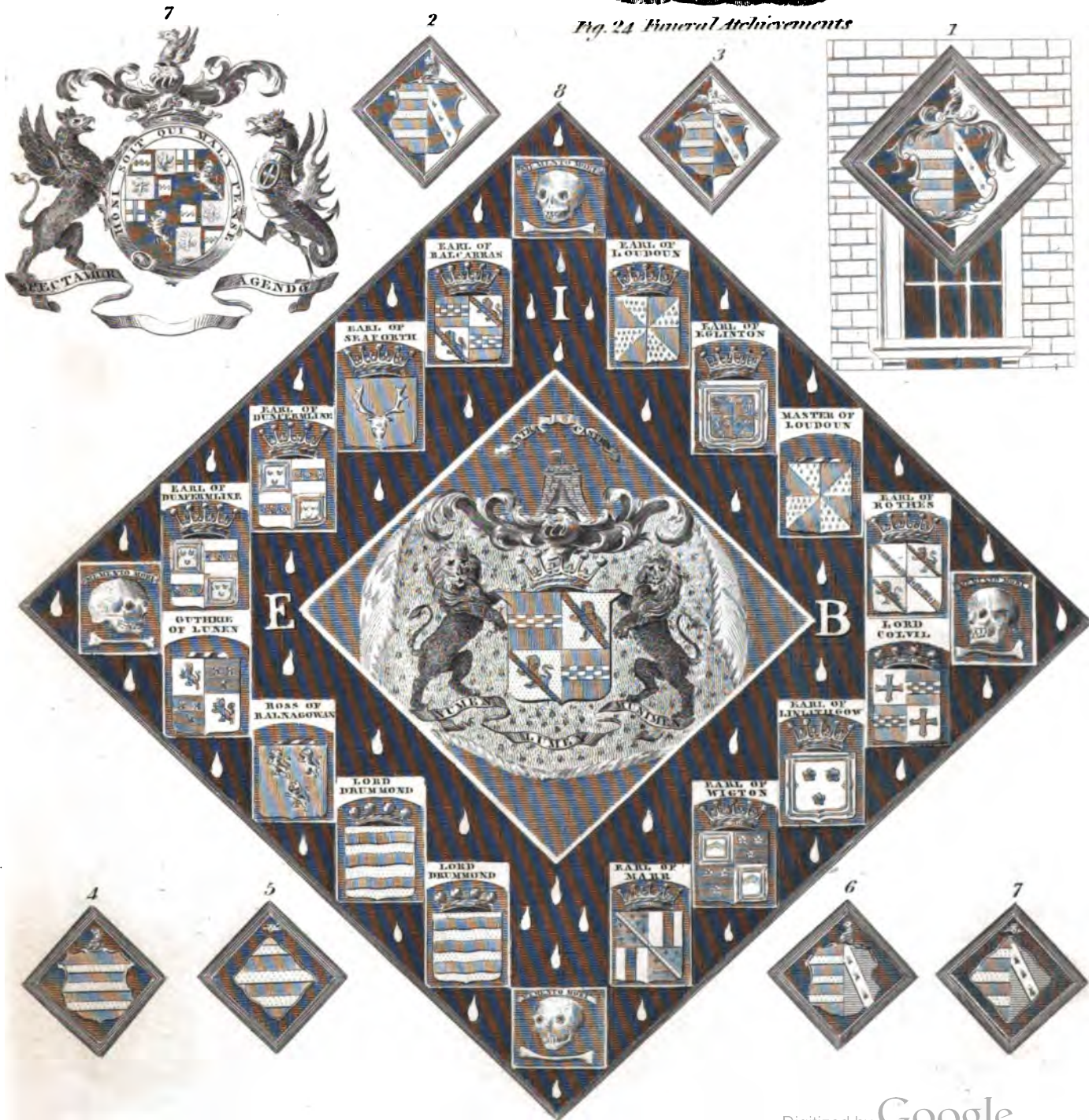

Fig. 24 Funeral Achievements



Escut-
cont.

The funeral escutcheon, as exhibited in Scotland, France, and Germany, is in form of a lozenge, above six feet square of black cloth; in the centre of which is painted, in proper colours, the complete achievement of the defunct, with all its exterior ornaments and additional marks or badges of honour; and round the sides are placed the sixteen arms of the families from which he derives his descent, as far back as the grandfather's grandfather, as the proofs of his gentility: they exhibit the armorial bearings of his father and mother, his two grandmothers, his four great-grandmothers, and his eight great-grandmothers mothers; if all these families have acquired a legal right to bear arms, then the gentility of the person whose

proof it is must be accounted complete, but not otherwise. On the four corners are placed mort-heads, and the initials of his name and titles or designation; and the black interstices are semée or powdered with tears, as in the figure, N° 8. which is the escutcheon of the right honourable James 5th earl of Balcarras, chief of the ancient surname of *Lindesay*.

Of Escut-
cheons.

On the morning of the interment, one of these is placed on the front of the house where the deceased lies; and another on the church in which he is to be buried, which after the burial is fixed above the grave. The pall, too, is generally adorned with these proofs of gentility, and the horses of the hearse with the defunct's arms.

H E R

raldus
Herbace-
Plants.

HERALDUS, DESIDERIUS, in French *Herault*, a counsellor of the parliament of Paris, has given good proofs of uncommon learning by very different works. His *Adversaria* appeared in 1599; which little book, if the *Scaligerana* may be credited, he repented the having published. His notes on Tertullian's Apology, on Minutius Felix, and on Arnobius, have been esteemed. He also wrote notes on Martial's Epigrams. He disguised himself under the name of *David Leidhresserus*, to write a political dissertation on the independence of kings, some time after the death of Henry IV. He had a controversy with Salmasius, *De jure Attico ac Romano*; but did not live to finish what he had written on that subject. What he had done, however, was printed in 1650. He died in June 1649. Guy Patin says, that "he was looked upon as a very learned man, both in the civil law and in polite literature, and wrote with great facility on any subject he pitched on." Gaille, speaking of such Protestant writers as condemned the executing of Charles I. king of England, quotes the *Pacifique Royal en deuil*, by Herault. This author, son to our Desiderius Heraldus, was a minister in Normandy, when he was called to the service of the Walloon-church of London under Charles I. and he was so zealous a royalist, that he was forced to fly to France, to escape the fury of the commonwealthmen. He returned to England after the Restoration, and resumed his ancient employment in the Walloon-church at London; some time after which he obtained a canonry in the cathedral of Canterbury, and enjoyed it till his death.

HERB, in *Botany*, a name by which Linnæus denominates that portion of every vegetable which arises from the root, and is terminated by the fructification. It comprehends, 1. The trunk, stalk, or stem. 2. The leaves. 3. Those minute external parts called by the same author the *fulcra* or supports of plants. 4. The buds, or, as he also terms them, the *winter-quarters* of the future vegetable.

HERB-Christopher. See **ACTEA**, **BOTANY Index**.

HERB-Robert, a species of **GERANIUM**. See **GERANIUM**, **BOTANY Index**.

HERBACEOUS PLANTS, are those which have succulent stems or stalks that die down to the ground

H E R

every year. Of herbaceous plants, those are annual which perish stem and root and all every year; biennial, which subsist by the roots two years; perennial which are perpetuated by their roots for a series of years, a new stem being produced every spring.

Herbace-
ous Plants
Herbert.

HERBAGE, in *Law*, signifies the pasture provided by nature for the food of cattle; also the liberty to feed cattle in the forest, or in another person's ground.

HERBAL, signifies a book that treats of the classes, genera, species, and virtues of plants.

HERBAL, is sometimes also used for what is sometimes called *hortus siccus*, or a collection of dried plants.

HERBELOT, BARTHOLEMEW D', a French writer, eminent for his oriental learning, was born at Paris in 1625. He travelled several times into Italy, where he obtained the esteem of some of the most learned men of the age. Ferdinand II. grand duke of Tuscany, gave him many marks of his favour; a library being exposed to sale at Florence, the duke desired him to examine the manuscripts in the oriental languages, to select the best of them, and to mark the price; which being done, that generous prince purchased them, and made him a present of them. M. Colbert being at length informed of Herbelot's merit, recalled him to Paris, and obtained a pension for him of 1500 livres: he afterwards became secretary and interpreter of the oriental languages, and royal professor of the Syriac tongue. He died at Paris in 1695. His principal work is entitled *Bibliothèque Orientale*, which he first wrote in Arabic, and afterwards translated into French. It is greatly esteemed. M. Herbelot's modesty was equal to his erudition; and his uncommon abilities were accompanied with the utmost probity, piety, and charity, which he practised through the whole course of his life.

HERBERT, MARY, countess of Pembroke, was sister of the famous Sir Philip Sidney, and wife of Henry earl of Pembroke. She was not only a lover of the muses, but a great encourager of polite literature; a character not very common among ladies. Her brother dedicated his incomparable romance *Arcadia* to her, from which circumstance it hath been called *The Countess of Pembroke's Arcadia*. She translated a dramatic

Herbert.

matic piece from the French, entitled *Antonius*, a tragedy; though it is said she was assisted by her lord's chaplain, Dr Babington, afterwards bishop of Exeter. She also turned the Psalms of David into English metre; but it is doubtful whether these works were ever printed. She died in 1621; and an exalted character of her is to be found in Francis Osborne's *Memoirs of King James I.*

HERBERT, Edward, Lord Herbert of Cherbury in Shropshire, an eminent English writer, was born in 1581, and educated at Oxford, after which he travelled, and at his return was made knight of the Bath. James I. sent him ambassador to Louis XIII. in behalf of the Protestants who were besieged in several cities of France; and continued in this station till he was recalled, on account of a dispute between him and the constable de Luines. In 1625 he was advanced to the dignity of a baron in the kingdom of Ireland, by the title of Lord Herbert of Castle Island; and in 1631 to that of Lord Herbert of Cherbury in Shropshire. After the breaking out of the civil wars, he adhered to the parliament; and in 1644 obtained a pension, on account of his having been plundered by the king's forces. He wrote a *History of the Life and Reign of Henry VIII.* which was greatly admired; a treatise *De veritate*; and several other works. He died at London in 1648.

"Lord Herbert (says Mr Cranger), stands in the first rank of the public ministers, historians, and philosophers of his age. It is hard to say whether his person, his understanding, or his courage, was the most extraordinary; as the fair, the learned, and the brave, held him in equal admiration. But the same man was wise and capricious; redressed wrongs, and quarrelled for punctilios; hated bigotry in religion, and was himself a bigot to philosophy. He exposed himself to such dangers as other men of courage would have carefully declined: and called in question the fundamentals of a religion which none had the hardness to dispute besides himself."

HERBERT, William, earl of Pembroke, was born at Wilton in Wiltshire, 1580; and admitted to New-college in Oxford in 1592, where he continued about two years. In 1601 he succeeded to his father's honours and estate; was made K. G. in 1604; and governor of Portsmouth six years after. In 1626, he was elected chancellor of the university of Oxford: and about the same time made lord steward of the king's household. He died suddenly at his house called *Baynard's castle*, in London, April 10. 1630; according to the calculation of his nativity, says Wood, made several years before by Mr Thomas Allen of Gloucester-hall. Clarendon relates concerning this calculation, that some considerable persons connected with Lord Pembroke being met at Maidenhead, one of them at supper drank a health to the lord steward; upon which another said, that he believed his lordship was at that time very merry; for he had now outlived the day, which it had been prognosticated upon his nativity he would not outlive; but he had outlived it now, for that was his birth day, which had completed his age to 50 years. The next morning, however, they received the news of his death. Whether the noble historian really believed this and other accounts relating to astrology, apparitions, providential interpositions,

2

&c. which he has inserted in his history, we do not presume to say: he delivers them, however, as if he did not actually disbelieve them. Lord Pembroke was not only a great favourite of learned and ingenious men, but was himself learned, and endowed with a considerable share of poetic genius. All that are extant of his productions in this way were published with this title: "Poems written by William earl of Pembroke, &c. many of which are answered by way of repartee by Sir Benjamin Rudyard, with other poems written by them occasionally and apart," 1660, 8vo.

HERBERT, Sir Thomas, an eminent gentleman of the Pembroke family, was born at York, where his father was an alderman. William earl of Pembroke sent him to travel at his expence in 1626, and he spent four years in visiting Asia and Africa: his expectations of preferment ending with the death of the earl, he went abroad again, and travelled over several parts of Europe. In 1634, he published, in folio, a *Relation of some Years Travel into Africa and the Great Asia*, especially the Territories of the Persian monarchy, and some parts of the Oriental Indies and isles adjacent. On the breaking out of the civil war, he adhered to the Parliament; and at Oldenby, on the removal of the king's servants, by the desire of the commissioners from the parliament, he and James Harrington were retained as grooms of his bed-chamber, and attended him even to the block. At the Restoration he was created a baronet by Charles II. for his faithful services to his father during his two last years. In 1678 he wrote *Threnodia Carolina*, containing an account of the two last years of the life of Charles I. and he assisted Sir William Dugdale in compiling the third volume of his *Monasticon Anglicanum*. He died at York in 1682, leaving several MSS. to the public library at Oxford, and others to that of the cathedral at York.

HERBIVOROUS ANIMALS, those which feed only on vegetables.

HERCULANEUM is the name of an ancient city of Campania in Italy, which was destroyed by an eruption of Vesuvius in the first year of the emperor Titus, or the 79th of the Christian era, and lately rendered famous on account of the curious monuments of antiquity discovered in its ruins; an account of which has been published by order of the king of Naples, in a work of six volumes folio.—The epocha of the foundation of Herculaneum is unknown. Dionysius Halicarnassensis conjectures that it may be referred to 60 years before the war of Troy, or about 1342 years before Christ; and therefore that it lasted about 1400 years.

The thickness of the heap of lava and ashes by which the city was overwhelmed, has been much increased by fiery streams vomited since that catastrophe; and now forms a mass 24 feet deep, of dark gray stone, which is easily broken to pieces. By its non-adhesion to foreign bodies, marbles and bronzes are preserved in it as in a case made to fit them; and exact moulds of the faces and limbs of statues are frequently found in this substance. The precise situation of this subterraneous city was not known till the year 1713, when it was accidentally discovered by some labourers, who, in digging a well, struck upon a statue on the benches of the theatre. Many others were afterwards dug out and sent to France by the prince of Elbeuf.

But

Herculaneum.

But little progress was made in the excavations till Charles infant of Spain ascended the Neapolitan throne; by whose unwearied efforts and liberality a very considerable part of Herculaneum has been explored, and such treasures of antiquity drawn out as form the most curious museum in the world. It being too arduous a task to attempt removing the covering, the king contented himself with cutting galleries to the principal buildings, and causing the extent of one or two of them to be cleared. Of these the theatre is the most considerable. On a ballustrade which divided the orchestra from the stage was found a row of statues; and, on each side of the pulpitum, the equestrian figure of a person of the Nonia family. They are now placed under porticoes of the palace; and from the great rarity of equestrian statues in marble would be very valuable objects, were their workmanship even less excellent than it is: one of them in particular is a very fine piece of sculpture. Since the king of Spain left Naples, the digging has been continued, but with less spirit and expenditure: indeed the collection of curiosities brought out of Herculaneum and Pompeii is already so considerable, that a relaxation of zeal and activity becomes excusable. They are now arranged in a wing of the palace; and consist not only of statues, busts, altars, inscriptions, and other ornamental appendages of opulence and luxury; but also comprehend an entire assortment of the domestic, musical, and surgical instruments used by the ancients; tripods of elegant form and exquisite execution, lamps in endless variety, vases and basons of noble dimensions, chandeliers of the most beautiful shapes, pateras and other appurtenances of sacrifice, looking-glasses of polished metal, coloured glass, so hard, clear, and well stained, as to appear emeralds, sapphires, and other precious stones; a kitchen completely fitted up with copper-pans lined with silver, kettles, cisterns for heating water, and every utensil necessary for culinary purposes; specimens of various sorts of combustibles, retaining their form though burnt to a cinder; corn, bread, fish, oil, wine, and flour; a lady's toilet, fully furnished with combs, thimbles, rings, paint, earrings, &c. Among the statues, which are numerous, connoisseurs allow the greatest share of merit to a Mercury and a sleeping faun: the busts fill several rooms; but very few of the originals whom they were meant to imitate are known. The floors are paved with ancient mosaic. Few rare medals have been found in these ruins; the most curious is a gold medallion of Augustus struck in Sicily in the 15th year of his reign. The fresco paintings, which, for the sake of preservation, have been torn off the walls and framed and glazed, are to be seen in another part of the palace. "The elegance of the attitudes, and the infinite variety of the subjects (Mr Swinburne observes), stamp them as performances worthy of the attention of artists and antiquarians; but no pictures yet found are masterly enough to prove that the Greeks carried the art of painting to as great a height of perfection as they did that of statuary. Yet can we suppose those authors incapable of appreciating the merits of an Apelles or a Zeuxis, who with so much critical discernment have pointed out the beauties of the works of a Phidias or a Praxiteles, beauties that we have still an opportunity of contemplating? would they have bestowed

equal praises upon both kinds of performances if either of them had been much inferior to the other? I think it is not probable; and we must presume, that the capital productions of the ancient painters, being of more perishable materials than busts and statues, have been destroyed in the fatal disasters that have so often afflicted both Greece and Italy. Herculaneum and Pompeii were but towns of the second order, and not likely to possess the masterpieces of the great artists, which were usually destined to adorn the more celebrated temples, or the palaces of kings and emperors." A more valuable acquisition than bronzes and pictures was thought to be made, when a large parcel of manuscripts was found among the ruins. Hopes were entertained that many works of the classics, which time has deprived us of, were now going to be restored to light, and that a new mine of science was on the point of being opened. But the difficulty of unrolling the burnt parchment, of pasting the fragments on a flat surface, and of deciphering the obscure letters, have proved such obstacles, that very little progress has been made in the work. A priest invented the method of proceeding; but it was found not to answer. A great many other processes have since been tried, but none has been entirely successful. And the value of the writings which has been unrolled has by no means corresponded to the public expectation. See HERCULANEUM, SUPPLEMENT.

Herculaneum, Hercules.

HERCULES, in fabulous history, a most renowned Grecian hero, who after death was ranked among the gods, and received divine honours. According to the ancients, there were many persons of the same name. Diodorus mentions three, Cicero six, and some authors extend the number to no less than forty-three. Of all these, one generally called the *Theban Hercules*, is the most celebrated; and to him, as may easily be imagined, the actions of the others have been attributed. He is reported to have been the son of Jupiter by Alcmena (wife to Amphitryon king of Argos), whom Jupiter enjoyed in the shape of her husband while he was absent; and in order to add the greater strength to the child, made that amorous night as long as three. Amphitryon having soon after accidentally killed his uncle and father-in-law Electryon, was obliged to fly to Thebes, where Hercules was born. The jealousy of Juno, on account of her husband's amour with Alcmena, prompted her to destroy the infant. For this purpose she sent two serpents to kill him in the cradle, but young Hercules strangled them both. He was early instructed in the liberal arts, and Castor the son of Tyndarus taught him how to fight, Eurytus how to shoot with a bow and arrows, Autolicus to drive a chariot, Linus to play on the lyre, and Eumolpus to sing. He, like the rest of his illustrious contemporaries, soon after became the pupil of the centaur Chiron, and under him he perfected and rendered himself the most valiant and accomplished of the age. In the 18th year of his age he resolved to deliver the neighbourhood of Mount Cithæron from a huge lion which preyed on the flocks of Amphitryon his supposed father, and which laid waste the adjacent country. He went to the court of Thespius king of Thespiæ, who shared in the general calamity; and he received here a tender treatment, and was entertained during 50 days. The 50 daughters of the king became mothers by Hercules

Hercules. during his stay at Thebes, and some say that it was effected in one night. After he had destroyed the lion of Mount Cithæron, he delivered his country from the annual tribute of 100 oxen which it paid to Erginus. Such public services became universally known; and Creon, who then sat on the throne of Thebes, rewarded the patriotic deeds of Hercules by giving him his daughter in marriage, and entrusting him with the government of his kingdom.

Euristheus, the son of Amphitryon, having succeeded his father, soon became jealous of Hercules; and fearing lest he might by him be deprived of his crown, left no means untried to get rid of him. Of this Hercules was not insensible, because he was perpetually engaging him on some desperate expedition; and therefore went to consult the oracle. But being answered that it was the pleasure of the gods that he should serve Euristheus 12 years, he fell into a deep melancholy, which at last ended in a furious madness; during which, among other desperate actions, he put away his wife Megara, and murdered all the children he had by her. As an expiation of this crime, the king imposed upon him twelve labours surpassing the power of all other mortals to accomplish, which nevertheless our hero performed with great ease. The favours of the gods had indeed completely armed him when he undertook his labours. He had received a coat of armour and helmet from Minerva, a sword from Mercury, a horse from Neptune, a shield from Jupiter, a bow and arrows from Apollo, and from Vulcan a golden cuirass and brazen buskin, with a celebrated club of brass according to the opinion of some writers.

The first labour imposed upon him was the killing of a lion in Nemea, a wood of Achaia; whose hide was proof against any weapon, so that he was forced to seize him by the throat and strangle him. He carried the dead beast on his shoulders to Mycenæ, and ever after clothed himself with the skin. Euristheus was so astonished at the sight of this beast, and at the courage of Hercules, that he ordered him never to enter the gates of the city when he returned from his expeditions, but to wait for his orders without the walls. He even made himself a brazen vessel into which he retired whenever Hercules returned.—The second labour was to destroy the Lernæan hydra, which had seven heads according to Apollodorus, 50 according to Simonides, and 100 according to Diodorus. This celebrated monster he first attacked with his arrows; but soon after he came to a close engagement, and by means of his heavy club he destroyed the heads of his enemy. This, however, was productive of no advantage; for as soon as one head was beaten to pieces by the club, immediately two sprang up; and the labour of Hercules would have remained unfinished, had not he commanded his friend Iolas to burn with a hot iron the root of the head which he had crushed to pieces. This succeeded; and Hercules became victorious, opened the belly of the monster, and dipped his arrows in the gall to render the wounds which he gave fatal and incurable.—He was ordered in his third labour to bring alive and unhurt into the presence of Euristheus a stag, famous for its incredible swiftness, its golden horns, and brazen feet. This celebrated animal frequented the neighbourhood of Oenoe; and Hercules

was employed for a whole year in continually pursuing it: at last he caught it in a trap, or when tired, or, according to others, by slightly wounding it and lessening its swiftness.—The fourth labour was to bring alive to Euristheus a wild boar which ravaged the neighbourhood of Erymanthus. In this expedition he destroyed the centaurs, and caught the boar by closely pursuing him through the deep snow. Euristheus was so frightened at the sight of the boar, that, according to Diodorus, he hid himself in his brazen vessel for some days.—In his fifth labour Hercules was ordered to clean the stables of Augeas, where 3000 oxen had been confined for many years.—For his sixth labour he was ordered to kill the carnivorous birds which ravaged the country near the lake Stymphalis in Arcadia.—In his seventh labour he brought alive into Peloponnesus a prodigious wild bull which laid waste the island of Crete.—In his eighth labour he was employed in obtaining the mares of Diomedes, which fed upon human flesh. He killed Diomedes, and gave him to be eaten by his mares, which he brought to Euristheus. They were sent to Mount Olympus by the king of Mycenæ, where they were devoured by the wild beasts; or, according to others, they were consecrated to Jupiter, and their breed still existed in the age of Alexander the Great.—For his ninth labour, he was commanded to obtain the girdle of the queen of the Amazons.—In his tenth labour he killed the monster Geryon king of Gades, and brought to Argos his numerous flocks which fed upon human flesh. This was in Iberia or Spain; in the furthest parts of which he erected his two pillars, as the utmost limits of the then known world. These ten labours he achieved, as the fable says, in about eight years. In this last expedition he is likewise affirmed to have killed Antæus, a famous giant of a monstrous size, who, when weary with wrestling or labour, was immediately refreshed by touching the earth. Hercules overcame him in wrestling, and slew him; and after him the tyrant Busiris, in his way through Egypt. This bloody man used to sacrifice all his guests and strangers upon his altars; and designing to have done the same by Hercules, was slain by him, together with all his attendants.—His eleventh labour was the carrying away the Hesperian golden apples kept by a dragon: (See HESPERIDES).—The twelfth and last, and most dangerous of his labours, was to bring upon earth the three-headed dog Cerberus. Descending into hell by a cave on Mount Tænarus, he was permitted by Pluto to carry away his friends Theseus and Pirithous, who were condemned to punishment in hell, and Cerberus also was granted to his prayers, provided he made use of no arms but only force to drag him away. Hercules, as some report, carried him back to hell after he had brought him before Euristheus.

Many other exploits are said to have been performed by Hercules; in particular, he accompanied the Argonauts to Colchis before he delivered himself up to the king of Mycenæ. He assisted the gods in their wars against the giants, and it was through him alone that Jupiter obtained a victory. He conquered Laomedon, and pillaged Troy. When Iole, the daughter of Eurytus king of Oechalia, of whom he was deeply enamoured, was refused to his intreaties, he became the prey of a second fit of insanity, and he murdered

Iphitus,

erules. Iphitus, the only one of the sons of Eurystus who favoured his addresses to Iole. He was some time after purified of the murder, and his insanity ceased; but the gods persecuted him, and he was visited by a disorder which obliged him to apply to the oracle of Delphi for relief. The coldness with which the Pythia received him irritated him, and he resolved to plunder Apollo's temple and carry away the sacred tripod. Apollo opposed him, and a severe conflict was begun, which nothing but the interference of Jupiter with his thunderbolts could have prevented. He was upon this told by the oracle that he must be sold as a slave, and remain three years in the most abject servitude to recover from his disorder. He complied; and Mercury, by order of Jupiter, conducted him to Omphale, queen of Lydia, to whom he was sold as a slave. Here he cleared all the country from robbers; and Omphale, who was astonished at the greatness of his exploits, married him. Hercules had Agelaus and Lamon by Omphale, from whom Cræsus king of Lydia was descended. He became also enamoured of one of Omphale's female servants, by whom he had Alceus. After he had completed the years of his slavery, he returned to Peloponnesus, where he re-established on the throne of Sparta Tyndarus, who had been expelled by Hippocoon. He became one of Dejanira's suitors, and married her after he had overcome all his rivals. He was obliged to leave Calydon his father-in-law's kingdom, because he had inadvertently killed a man with a blow of his fist, and it was on account of this expulsion that he was not present at the hunting of the Calydonian boar. From Calydon he retired to the court of Ceyx king of Trachinias. The king received him and his wife with great marks of friendship, and purified him of the murder which he had committed at Calydon. Hercules was still mindful that he had once been refused the hand of Iole; he therefore made war against her father Eurystus, and killed him with three of his sons. Iole fell into the hands of her father's murderer, and found that she was loved by Hercules as much as before. She accompanied him to Mount Oeta, where he was going to raise an altar and offer a solemn sacrifice to Jupiter. As he had not then the shirt and tunic in which he arrayed himself to offer a sacrifice, he sent Lichas to Trachin to his wife Dejanira, in order to provide himself a proper dress. Dejanira had some time before been attempted by the Centaur Nessus, as he was ferrying her over the river Euenus; and Hercules beholding it from the shore, had given him a mortal wound with an arrow. The monster finding himself dying, advised her to mix some oil with the blood which flowed from his wound, and to anoint her husband's shirt with it, pretending that it would infallibly secure him from loving any other woman; and she, too well apprised of his inconstancy, had actually prepared the poisoned ointment accordingly.—Lichas coming to her for the garments, unfortunately acquainted her with his having brought away Iole; upon which she, in a fit of jealousy, anointed his shirt with the fatal mixture. This had no sooner touched his body, than he felt the poison diffuse itself through all his veins; the violent pain of which caused him to disband his army, and to return to Trachin. His torment still increasing, he sent to consult the

oracle for a cure; and was answered, that he should cause himself to be conveyed to Mount Oeta, and there rear up a great pile of wood, and leave the rest to Jupiter. By the time he had obeyed the oracle, his pains being become intolerable, he dressed himself in his martial habit, flung himself upon the pile, and desired the bystanders to set fire to it. Others say that he left the charge of it to his son Philoctetes; who having performed his father's command, had his bow and arrows given him as a reward for his obedience. At the same time Jupiter, to be as good as his word, sent a flash of lightning, which consumed both the pile and the hero; insomuch that Iollaus, coming to take up his bones, found nothing but ashes: from which they concluded, that he was passed from earth to heaven, and joined to the gods. His friends showed their gratitude to his memory by raising an altar where the burning pile had stood. Menætius the son of Actor offered him a sacrifice of a bull, a wild boar, and a goat, and enjoined the people of Opus yearly to observe the same religious ceremonies. His worship soon became as universal as his fame; and Juno, who had once persecuted him with such fury forgot her resentment, and gave him her daughter Hebe in marriage. Hercules has received many surnames and epithets, either from the place where his worship was established, or from the labours which he achieved. His temples were numerous and magnificent, and his divinity revered. No dogs or flies ever entered his temple at Rome; and that of Gades, according to Strabo, was always forbidden to women and pigs. The Phœnicians offered quails on his altars; and as it was supposed that he presided over dreams, the sick and infirm were sent to sleep in his temples, that they might receive in their dreams the agreeable presages of their approaching recovery. The white poplar was particularly dedicated to his service.

It is observed, that there are none even of the twelve great gods of antiquity that have so many ancient monuments relating to them as Hercules. The famous statue of Hercules, in the Farnese palace at Rome, is well known to the connoisseurs: this represents him resting after the last of his twelve labours above recited, leaning on his club, and holding the apples of the Hesperides in his hand. In this statue, as in all the other figures of him, he is formed, by the breadth of his shoulders, the spaciousness of his chest, the largeness of his size, and the firmness of his muscles, to express strength and a capacity of enduring great fatigue, which constituted the chief idea of virtue among the ancient heathens. His other attributes are his lion's skin, his club, and his bow.—Hercules is represented by the ancients as an exemplar of virtue: however, the *Hercules Bibas*, or drunken Hercules, is no uncommon figure; and his amours are described both by the poets and artists. Thus, the Cupids are made to take away his club, and he is exhibited in the posture of bending under a little boy; by which actions we perceive, that he who conquered all difficulties was a slave to love. His children are as numerous as the labours and difficulties which he underwent; and indeed they became so powerful soon after his death, that they alone had the courage to invade all Peloponnesus. See HERACLIDÆ.

Hercules.

The.

Hercules
Hereditary
Right.

The apotheosis of Hercules, or the establishment of his altars in the principal cities of Greece, is fixed by Thrasylbulus 29 years before the taking of Troy.

Hercules has been particularly honoured by the Greeks under the name of *Musagetes*, "the conductor of the Muses;" and at Rome under that of *Hercules Musarum*. He is represented on medals with a lyre in his hand; and the reverse is marked with the figure of the nine Muses, with their proper symbols.

HERCULES, in *Astronomy*, one of the constellations of the northern hemisphere.—The stars in the constellation Hercules in Ptolemy's catalogue are 29; in Tycho's, 28; in the Britannic catalogue, 113.

HERCULES's Pillars, in antiquity, a name given to two lofty mountains, one situated on the most southern extremity of Spain, and the other on the opposite part of Africa. They were called by the ancients *Abyla* and *Calpe*. They were reckoned the boundaries of the labours of Hercules; and according to ancient tradition, they were joined together till they were severed by the arm of the hero, and a communication opened between the Mediterranean and Atlantic seas.

HERCYNIA SILVA, in *Ancient Geography*, the largest of forests. Its breadth was a journey of nine days to the best traveller. Taking its rise at the limits of the Helvetii, Nemetes, and Rauraci, it run along the Danube to the borders of the Daci and Anartes, a length of 60 days journey, according to Cæsar, who appears to have been well acquainted with its true breadth, seeing it occupied all Lower Germany. It may therefore be considered as covering the whole of Germany; and most of the other forests may be considered as parts of it, though distinguished by particular names: consequently the Hartz, in the duchy of Brunswick, which gave name to the whole, may be considered as one of its parts. The name *Hartz* denotes "resinous," or, "pine-trees." By the Greeks it is called *Or-cynius*, as a name common to all the forests in Germany; in the same manner as *Hercynius* was the name given by the Romans; and both from the German *Hartz*.

HERD, among hunters, an assemblage of black or fallow beasts in contradistinction to *stock*. See FLOCK.—In the hunting language there are various terms used for companies of the divers kinds of game. We say a *herd* of harts or bucks, a *bevy* of roes, a *roust* of wolves, a *richess* of martens, &c.

HEREDITAMENTS, whatever moveable things a person may have to himself and his heirs by way of inheritance; and which, if not otherwise bequeathed, descend to him who is next heir, and not to the executor as chattels do.

HEREDITARY, an appellation given to whatever belongs to a family by right of succession from heir to heir.

HEREDITARY is also figuratively applied to good or ill qualities supposed to be transmitted from father to son: thus we say virtue and piety are hereditary qualities in such a family; and that in Italy the hatred of families is hereditary. And indeed the gout, king's evil, madness, &c. may really be hereditary diseases.

HEREDITARY Right, in the British constitution. The grand fundamental maxim upon which the *jus coronæ*, or right of succession to the throne of Britain depends, Sir William Blackstone takes to be this: That the crown is, by common law and constitutional custom,

hereditary, and this in a manner peculiar to itself: but that the right of inheritance may from time to time be changed or limited by act of parliament; under which limitations the crown still continues hereditary.

1. The crown is in general hereditary, or descendible to the next heir, on the death or demise of the last proprietor. All regal governments must be either hereditary or elective: and as there is no instance wherein the crown of England has ever been asserted to be elective, except by the regicides at the infamous and unparalleled trial of King Charles I.; it must of consequence be hereditary. Yet in thus asserting an hereditary right, a *jure divino* title to the throne is by no means intended. Such a title may be allowed to have subsisted under the theocratic establishments of the children of Israel in Palestine; but it never yet subsisted in any other country; save only so far as kingdoms, like other human fabrics, are subject to the general and ordinary dispensations of Providence. Nor indeed have a *jure divino* and an hereditary right any necessary connection with each other; as some have very weakly imagined. The titles of David and Jehu were equally *jure divino* as those of either Solomon or Ahab; and yet David slew the sons of his predecessor, and Jehu his predecessor himself. And when our kings have the same warrant as they had, whether it be to sit upon the throne of their fathers, or to destroy the house of the preceding sovereign, they will then, and not before, possess the crown of England by a right like theirs, immediately derived from heaven. The hereditary right, which the laws of England acknowledge, owes its origin to the founders of our constitution, and to them only. It has no relation to, nor depends upon, the civil laws of the Jews, the Greeks, the Romans, or any other nation upon earth; the municipal laws of one society having no connection with, or influence upon, the fundamental polity of another. The founders of our English monarchy might perhaps, if they had thought proper, have made it an elective monarchy; but they rather chose, and upon good reason, to establish originally a succession by inheritance. This has been acquiesced in by general consent, and ripened by degrees into common law; the very same title that every private man has to his own estate. Lands are not naturally descendible, any more than thrones: but the law has thought proper, for the benefit and peace of the public, to establish hereditary succession in the one as well as the other.

It must be owned, an elective monarchy seems to be the most obvious, and best suited of any to the rational principles of government, and the freedom of human nature; and accordingly we find from history, that, in the infancy and first rudiments of almost every state, the leader, chief magistrate, or prince, hath usually been elective. And, if the individuals who compose that state could always continue true to first principles, uninfluenced by passion or prejudice, unassailed by corruption, and unawed by violence, elective succession were as much to be desired in a kingdom as in other inferior communities. The best, the wisest, and the bravest man, would then be sure of receiving that crown which his endowments have merited; and the sense of an unbiassed majority would be dutifully acquiesced in by the few who were of different opinions. But history and observation will inform us, that elections of every kind

Hereditary kind (in the present state of human nature) are too frequently brought about by influence, partiality, and artifice; and, even where the case is otherwise, these practices will be often suspected, and as constantly charged upon the successful, by a sullenly disappointed minority. This is an evil to which all societies are liable; as well as those of a private and domestic kind, as the great community of the public, which regulates and includes the rest. But in the former there is this advantage, That such suspicions, if false, proceed no farther than jealousies and murmurs, which time will effectually suppress; and, if true, the injustice may be remedied by legal means, by an appeal to those tribunals to which every member of society has (by becoming such) virtually engaged to submit. Whereas, in the great and independent society which every nation composes, there is no superior to resort to but the law of nature; no method to redress the infringements of that law, but the actual exertion of private force. As therefore between two nations, complaining of mutual injuries, the quarrel can only be decided by the law of arms; so in one and the same nation, when the fundamental principles of their common union are supposed to be invaded, and more especially when the appointment of their chief magistrate is alleged to be unduly made, the only tribunal to which the complainants can appeal is that of the God of battles, the only process by which the appeal can be carried on is that of a civil and intestine war. An hereditary succession to the crown is therefore now established, in this and most other countries, in order to prevent that periodical bloodshed and misery, which the history of ancient imperial Rome, and the later experience of modern times, has shown to be the consequences of elective kingdoms.

2. But, secondly, as to the particular mode of inheritance. It in general corresponds with the feudal path of descents, chalked out by the common law in the succession to landed estates; yet with one or two material exceptions. Like them the crown will descend lineally to the issue of the reigning monarch; as it did from King John to Richard II. through a regular pedigree of six lineal generations: As in them the preference of males to females, and the right of primogeniture among the males, are strictly adhered to. Thus Edward V. succeeded to the crown, in preference to Richard his younger brother, and Elizabeth his eldest sister. Like them, on failure of the male line it descends to the issue female; according to the ancient British custom remarked by Tacitus, *Solent feminarum ductu bellare, et sexum in imperiis non discernere*. Thus Mary I. succeeded to Edward VI.; and the line of Margaret queen of Scots, the daughter of Henry VII. succeeded, on failure of the line of Henry VIII. his son. But among the females, the crown descends by right of primogeniture to the eldest daughter only and her issue; and not, as in common inheritance, to all the daughters at once; the evident necessity of a sole succession to the throne having occasioned the royal law of descents to depart from the common law in this respect: and therefore Queen Mary, on the death of her brother, succeeded to the crown alone, and not in partnership with her sister Elizabeth. Again, the doctrine of representation prevails in the descent of the crown, as it does in other inheritances; whereby

the lineal descendants of any person deceased stand in the same place as their ancestor, if living, would have done. Thus Richard II. succeeded his grandfather Edward III. in right of his father the Black Prince; to the exclusion of all his uncles, his grandfather's younger children. Lastly, on failure of lineal descendants, the crown goes to the next collateral relations of the late king; provided they are lineally descended from the blood-royal, that is, from that royal stock which originally acquired the crown. Thus Henry I. succeeded to William II. John to Richard I. and James I. to Elizabeth; being all derived from the Conqueror, who was then the only regal stock. But herein there is no objection (as in the case of common descents) to the succession of a brother, an uncle, or other collateral relation, of the half-blood; that is, where the relationship proceeds not from the same couple of ancestors (which constitutes a kinsman of the whole blood), but from a single ancestor only; as when two persons are derived from the same father, and not from the same mother, or *vice versa*: provided only, that the one ancestor, from whom both are descended, be that from whose veins the blood-royal is communicated to each. Thus Mary I. inherited to Edward VI. and Elizabeth inherited to Mary; all born of the same father, King Henry VIII. but all by different mothers. See the articles **CONBANGUINITY, DESCENT, and SUCCESSION.**

3. The doctrine of hereditary right does by no means imply an indefeasible right to the throne. No man will assert this, who has considered our laws, constitution, and history, without prejudice, and with any degree of attention. It is unquestionably in the breast of the supreme legislative authority of this kingdom, the king and both houses of parliament, to defeat this hereditary right; and by particular entails, limitations, and provisions, to exclude the immediate heir, and vest the inheritance in any one else. This is strictly consonant to our laws and constitution; as may be gathered from the expression so frequently used in our statute-book, of "the king's majesty, his heirs, and successors." In which we may observe, that as the word heirs necessarily implies an inheritance or hereditary right generally subsisting in the royal person; so the word *successors*, distinctly taken, must imply that the inheritance may sometimes be broken through; or, that there may be a successor, without being the heir of the king. And this is so extremely reasonable, that without such a power, lodged somewhere, our polity would be very defective. For, let us barely suppose so melancholy a case, as that the heir-apparent should be a lunatic, an idiot, or otherwise incapable of reigning; how miserable would the condition of the nation be, if he were also incapable of being set aside; —It is therefore necessary that this power should be lodged somewhere; and yet the inheritance and regal dignity would be very precarious indeed, if this power were expressly and avowedly lodged in the hands of the subject only, to be exerted whenever prejudice, caprice, or discontent, should happen to take the lead. Consequently it can nowhere be so properly lodged as in the two houses of parliament, by and with the consent of the reigning king; who, it is not to be supposed, will agree to any thing improperly prejudicial to the rights of his own descendants. And therefore in

Hereditary Right.

Hereditary the king, lords, and commons, and parliament assembled, our laws have expressly lodged it.

4. But, fourthly, However the crown may be limited or transferred, it still retains its descendible quality, and becomes hereditary in the wearer of it. And hence in our law the king is said never to die in his political capacity; though in common with other men, he is subject to mortality in his natural: because immediately upon the natural death of Henry, William, or Edward, the king survives in his successor. For the right of the crown vests *eo instanti*, upon his heir; either the *hæres natus*, if the course of descent remains unimpeached, or the *hæres factus*, if the inheritance be under any particular settlement. So that there can be no interregnum; but, as Sir Matthew Hale observes, the right of sovereignty is fully invested in the successor by the very descent of the crown. And therefore, however acquired, it becomes in him absolutely hereditary, unless by the rules of the limitation it is otherwise ordered and determined: In the same manner as landed estates, to continue our former comparison, are by the law hereditary, or descendible to the heirs of the owner; but still there exists a power, by which the property of those lands may be transferred to another person. If this transfer be made simply and absolutely, the lands will be hereditary in the new owner, and descend to his heir at law: but if the transfer be clogged with any limitations, conditions, or entails, the lands must descend in that channel, so limited and prescribed, and no other. See SUCCESSION.

HEREDITAS JACENS, in *Scots Law*. An estate is said to be *in hereditate jacente*, after the proprietor's death, till the heir's entry.

HEREFORD, which in Saxon signifies *the ford of the army*, the capital of Herefordshire in England, situated in W. Long. 2. 35. N. Lat. 52. 6. It is supposed to have risen out of the ruins of Kenchester, in its neighbourhood, which Camden believes to have been the *Ariconium* of Antoninus. It is very pleasantly situated among meadows and corn fields, and is almost encompassed with rivers. It seems to have owed its rise, or at least its increase, to the building and dedicating a church there to Ethelbert king of the East Angles, who was murdered in the neighbourhood, and afterwards taken into the catalogue of martyrs; soon after it became a bishop's see, and in consequence of that a considerable place. In 1055 it was sacked, the cathedral destroyed, and its bishop Leofgar carried away captive by Gryffin prince of South-Wales, and Algar, an Englishman, who had rebelled against Edward the Confessor. Harold fortified it with a broad and high rampart; and it appears by Doomsday book, that there were no more than 300 men within and without the wall. A very large and strong castle was built by the Normans along the Wye, and the city walled round. The present stately cathedral was founded in the reign of Henry I. by Bishop Reinelm, but enlarged and beautified by his successors. It suffered much in the barons wars; and was often taken and retaken in the war between King Charles I. and the parliament. This city is pretty large, and had once six churches; but two were destroyed in the civil wars. It is not very populous nor well built, many of the houses being old. Its manufactures are gloves and other leathern goods; and its corporation consists of a mayor, six aldermen, a high

steward, deputy-steward, and town-clerk; who have a sword-bearer and four serjeants at mace. Each of the companies enjoys distinct laws and privileges by their charter, and each has its hall. The cathedral, which was built in 1050, and destroyed by the Welsh in 1060, but rebuilt in the reign of the Conqueror, or, as some say, in that of Henry I. is a beautiful and magnificent structure, but being greatly decayed, part of it was destroyed by the fall of the tower in September 1786, and the spire on another tower was taken down to be rebuilt at the same time. Here is an hospital well endowed for 16 poor people; and two charity-schools, one for 60 boys, the other for 40 girls. The chapter-house, which was once a very elegant building, built about the year 1079, is now in ruins. Here were formerly two or three priories. Almost the only drink here is cyder, which is both cheap and good, the very hedges in the country being planted with apple-trees. The city gave the title of *earl* to the noble family of the Bohuns; then of *duke* to Henry of Lancaster, afterwards Henry IV. king of England; after him, of *earl* to Stafford earl of Buckingham; then of *viscount* to Devereux earl of Essex, which a collateral branch of his family still enjoys, and is thereby the premier viscount of England.

HEREFORDSHIRE, a county of England nearly of a circular form, bounded on the east by Worcester and Gloucester, on the south by Monmouthshire, on the west by Radnorshire and Brecknockshire, and on the north by Shropshire. Its length from north to south is 46 miles, its breadth from east to west 40. It contains 8 market towns, 87 vicarages, 176 parishes, and 391 villages. This county contains, according to the returns made to the house of commons, in 1811, 19,296 houses, occupied by 20,081 families; and the whole number of inhabitants was 94,073: of this number 46,404 were males, and 47,669 females. The number of families supported by agriculture was 12,559, by trade and manufactures 5044, the number of others 2438. The marriages in the preceding year were 663, the baptisms 2656. It is divided into 11 hundreds, and sends eight members to parliament, namely, two knights for the shire, and two for each of the following towns, Hereford, Lempster or Leominster, and Weobly.

The air of this county is allowed to be as pleasant, sweet, and wholesome, as that of any other in England, there being nothing either in the soil or situation to render it otherwise. The soil throughout is excellent, and inferior to none, either for grain, fruit, or pasture, supplying the inhabitants plentifully with all the necessaries of life: but that by which it is distinguished from most others, is its fruit, especially apples, of which it produces such quantities, that the cyder made of them is not only sufficient for their own consumption, though it is their ordinary drink, but also in a great measure for that of London and other parts. That in particular which is made from the apple called *redstreak*, is much admired, and has a body almost equal to that of white-wine. The county is well supplied with wood and water; for, besides lesser streams, there are the rivers Frome, Loden, Lug, Wye, Wadel, Arro, Dare, and Monow; the last of which is large, and all of them are well stored with fish, particularly the Wye, which breeds salmon. It lies in the diocese of Hereford, and Oxford circuit. See HEREFORDSHIRE, SUPPLEMENT.

Hereford,
Hereford-
shire.

renaussen
HERENAUSEN, a palace of Germany near
Hanover, formerly belonging to the king of Great
Britain. Here are lodgings for all the court; and a
garden of vast extent, in which are fine waterworks, a
labyrinth, and many other curiosities worthy the ob-
servation of a traveller.

HERENTHALS, a town of Brabant in the Ne-
therlands, in the quarter of Antwerp; seated on the
river Nethe, in E. Long. 4. 54. N. Lat. 51. 13.

HERESY, in Law, an offence against Christianity,
consisting in a denial of some of its essential doctrines,
publicly and obstinately avowed; being defined, *sen-
tentia rerum divinarum humano sensu excogitata, palam
docta et pertinaciter defensa*. And here it must be
acknowledged that particular modes of belief, or un-
belief, not tending to overturn Christianity itself, or to
sap the foundations of morality, are by no means the
object of coercion by the civil magistrate. What doc-
trines shall therefore be adjudged heresy, was left by
our old constitution to the determination of the eccle-
siastical judge; who had herein a most arbitrary lati-
tude allowed him. For the general definition of an
heretic given by Lyndewode, extends to the smallest
deviations from the doctrines of the holy church: *hæ-
reticus est qui dubitat de fide catholica, et qui negligit
servare ea, quæ Romana ecclesia statuit, seu servare de-
creverat*. Or, as the statute 2 Hen. IV. c. 15. ex-
presses it in English, "teachers of erroneous opinions
contrary to the faith and blessed determinations of the
holy church." Very contrary this to the usage of the
first general councils, which defined all heretical doc-
trines with the utmost precision and exactness. And
what ought to have alleviated the punishment, the un-
certainty of the crime, seems to have enhanced it in
those days of blind zeal and pious cruelty. It is true,
that the sanctimonious hypocrisy of the canonists went
at first no farther than enjoining penance, excommuni-
cation, and ecclesiastical deprivation, for heresy; though
afterwards they proceeded boldly to imprisonment by
the ordinary, and confiscation of goods *in pios usus*.
But in the mean time they had prevailed upon the
weakness of bigotted princes to make the civil power
subservient to their purposes, by making heresy not
only a temporal, but even a capital, offence: the Ro-
mish ecclesiastics determining, without appeal, what-
ever they pleased to be heresy, and shifting off to the
secular arm the odium and drudgery of executions;
with which they themselves were too tender and deli-
cate to intermeddle. Nay, they pretended to intercede
and pray, on behalf of the convicted heretic, *ut citra
mortis periculum sententia circa eum moderetur*: well
knowing that at the same time they were delivering the
unhappy victim to certain death. Hence the capital
punishments inflicted on the ancient Donatists and Ma-
nichæans by the emperors Theodosius and Justinian:
hence also the constitution of the emperor Frederic
mentioned by Lyndewode, adjudging all persons with-
out distinction to be burnt with fire who were convic-
ted of heresy by the ecclesiastical judge. The same
emperor, in another constitution, ordained, that if any
temporal lord, when admonished by the church, should
neglect to clear his territories of heretics within a year,
it should be lawful for good Catholics to seize and oc-
cupy the lands, and utterly to exterminate the hereti-
cal possessors. And upon this foundation was built

that arbitrary power, so long claimed and so fatally ex-
erted by the pope, of disposing even of the kingdoms
of refractory princes to more dutiful sons of the church.
The immediate event of this constitution was some-
thing singular, and may serve to illustrate at once the
gratitude of the holy see, and the just punishment of
the royal bigot; for, upon the authority of this very
constitution, the pope afterwards expelled this very em-
peror Frederic from his kingdom of Sicily, and gave it
to Charles of Anjou.

Christianity being thus deformed by the dæmon of
persecution upon the continent, we cannot expect that
our own island should be entirely free from the same
seourge. And therefore we find among our ancient
precedents a writ *de hæretico comburendo*, which is
thought by some to be as ancient as the common law
itself. However, it appears from thence, that the con-
viction of heresy by the common law was not in any
potty ecclesiastical court, but before the archbishop
himself in a provincial synod; and that the delinquent
was delivered over to the king to do as he should please
with him; so that the crown had a controul over the
spiritual power, and might pardon the convict by is-
suing no process against him; the writ *de hæretico com-
burendo* being not a writ of course, but issuing only by
the special direction of the king in council.

But in the reign of Henry IV. when the eyes of the
Christian world began to open, and the seeds of the
Protestant religion (though under the opprobrious name
of *lollardy*) took root in this kingdom; the clergy, tak-
ing advantage from the king's dubious title to demand
an increase of their own power, obtained an act of par-
liament, which sharpened the edge of persecution to its
utmost keenness. For, by that statute, the diocesan
alone, without the intervention of a synod, might con-
vict of heretical tenets; and unless the convict abjured
his opinions, or if after abjuration he relapsed, the sher-
iff was bound *ex officio*, if required by the bishop, to
commit the unhappy victim to the flames, without wait-
ing for the consent of the crown. By the statute
2 Hen. V. c. 7. *lollardy* was also made a temporal of-
fence, and indictable in the king's courts; which did
not thereby gain an exclusive, but only a concurrent,
jurisdiction with the bishop's consistory.

Afterwards, when the final reformation of religion
began to advance, the power of the ecclesiastics was
somewhat moderated; for though what heresy *is*, was
not then precisely defined, yet we are told in some
points what it *is not*: the statute 25 Hen. VIII. c. 14.
declaring, that offences against the see of Rome are not
heresy; and the ordinary being thereby restrained from
proceeding in any case upon mere suspicion; that is,
unless the party be accused by two credible witnesses,
or an indictment of heresy be first previously found in
the king's courts of common law. And yet the spirit
of persecution was not yet abated, but only diverted
into a lay channel. For in six years afterwards, by
statute 31 Hen. VIII. c. 14. the bloody law of the
six articles was made, which established the six most
contested points of popery, transubstantiation, com-
munion in one kind, the celibacy of the clergy, monastic
vows, the sacrifice of the mass, and auricular confession;
which points were "determined and resolved by the
most godly study, pain, and travail of his majesty: for
which his most humble and obedient subjects, the lords

Heresy. *spiritual* and temporal and the commons, in parliament assembled, did not only render and give unto his highness their most high and hearty thanks; but did also enact and declare all oppugners of the first to be heretics, and to be burnt with fire; and of the five last to be felons, and to suffer death. The same statute established a new and mixed jurisdiction of clergy and laity for the trial and conviction of heretics; the reigning prince being then equally intent on destroying the supremacy of the bishops of Rome, and establishing all other their corruptions of the Christian religion.

Without perplexing this detail with the various repeals and revivals of these sanguinary laws in the two succeeding reigns, let us proceed to the reign of Queen Elizabeth; when the reformation was finally established with temper and decency, unsullied with party-rancour, or personal caprice and resentment. By statute 1 Eliz. c. 1. all former statutes belonging to heresy are repealed, which leaves the jurisdiction of heresy as it stood at common law; viz. as to the infliction of common censures in the ecclesiastical courts; and in case of burning the heretic, in the provincial synod only. Sir Matthew Hale is indeed of a different opinion, and holds that such power resided in the diocesan also; though he agrees that in either case the writ *de hæretico comburendo* was not demandable of common right, but grantable or otherwise merely at the king's discretion. But the principal point now gained was, that by this statute a boundary is for the first time set to what shall be accounted heresy; nothing for the future being to be so determined, but only such tenets as have been heretofore so declared, 1. By the words of the holy scriptures; or, 2. By the first four general councils, or such others as have only used the words of the holy scriptures; or, 3. Which shall hereafter be so declared by the parliament, with the assent of the clergy in convocation. Thus was heresy reduced to a greater certainty than before; though it might not have been the worse to have defined it in terms still more precise and particular: as a man continued still liable to be burnt, for what perhaps he did not understand to be heresy, till the ecclesiastical judge so interpreted the words of the canonical scriptures.

For the writ *de hæretico comburendo* remained still in force; and we have instances of its being put in execution upon two Anabaptists in the 17th of Elizabeth, and two Arians in the 9th of James I. But it was totally abolished, and heresy again subjected only to ecclesiastical correction, *pro salute animæ*, by virtue of the statute 29 Car. II. c. 9.: for, in one and the same reign, our lands were delivered from the slavery of military tenures; our bodies from arbitrary imprisonment by the *habeas corpus* act; and our minds from the tyranny of superstitious bigotry, by demolishing this last badge of persecution in the English law.

Every thing is now as it should be, with respect to the spiritual cognizance, and spiritual punishment of heresy: unless perhaps that the crime ought to be more strictly defined, and no persecution permitted, even in the ecclesiastical courts, till the tenets in question are by proper authority previously declared to be heretical. Under these restrictions, it seems necessary for the support of the national religion, that the officers of the church should have power to censure heretics; yet not to harass them with temporal penalties, much less to

exterminate or destroy them. The legislature hath indeed thought it proper, that the civil magistrate should again interpose, with regard to one species of heresy very prevalent in modern times; for by statute 9 and 10 W. III. c. 32. if any person educated in the Christian religion, or professing the same, shall by writing, printing, teaching, or advised speaking, deny any one of the persons in the Holy Trinity to be God, or maintain that there are more gods than one, he shall undergo the same penalties and incapacities which were just now mentioned to be inflicted on apostasy by the same statute.

HERETIC, a general name for all such persons under any religion, but especially the Christian, as profess or teach religious opinions contrary to the established faith, or to what is made the standard of orthodoxy. See **HERESY**.

HERETOCHS, among our Saxon ancestors, signified the same with dukes or dukes, denoting the commanders or leaders of their armies.

It appears, from Edward the Confessor's laws, that the military force of this kingdom was in the hands of the dukes or heretochs, who were constituted through every province and county in the kingdom, being selected out of the principal nobility, and such as were most remarkable for being *sapientes, fideles, et animosi*. Their duty was to lead and regulate the English armies, with a very unlimited power; and because of their great power, they were elected by the people in their full assembly, or folk-mote, in the same manner as sheriffs were elected.

HERFORDEN, or **HERWARDEN**, a free and imperial town of Germany, in the circle of Westphalia, and capital of the county of Ravensberg. Here is a famous nunnery belonging to the Protestants of the confession of Augsburg, whose abbess is a princess of the empire, and has a voice and place in the diet. It is seated on the river Aa. E. Long. 8. 25. N. Lat. 52. 12.

HERGRUNDT, a town of Upper Hungary, remarkable for its rich mines of vitriol. Those who work in the mines have built a subterraneous town, which has a great number of inhabitants. E. Long. 18. 15. N. Lat. 48. 30.

HERIOT, in *Law*, a customary tribute of goods and chattels, payable to the lord of the fee on the decease of the owner of the land. See **TENURE**.

Heriot is of two sorts—viz. 1. *Heriot-custom*, where heriots have been paid time out of mind by custom, after the death of a tenant for life. In some places, there is a customary composition in money, as 10 or 20 shillings in lieu of a heriot, by which the lord and tenant are both bound, if it be an indisputably ancient custom; but a new composition of this sort will not bind the representatives of either party. 2. *Heriot-service*, when a tenant holds by such service to pay heriot at the time of his death; which service is expressed in the deed of feoffment.—For this latter the lord shall distrain; and for the other he shall seize, and not distrain. If the lord purchase part of the tenancy, heriot-service is extinguished; but it is not so of heriot-custom.

HERISSON, in *Fortification*, a beam armed with a great number of iron spikes with their points outwards, and supported by a pivot on which it turns. These serve as a barrier to block up any passage, and are frequently placed before the gates, and more especially the wicket-doors, of a town or fortress, to secure

Heresy
Heretic on

those passages which must of necessity be often opened and shut.

HERITABLE RIGHTS, in *Scots Law*, signify all rights affecting lands, houses, &c. or any immoveable subject.

HERITAGE, in *Scots Law*, lands, houses, or any immoveable subject, in contradistinction to moveables or moveable subjects. It also sometimes signifies such immoveable property as a person succeeds to as heir to another, in contradistinction to that which he himself purchases or acquires in any other manner, called *conquest*.

HERMÆA, in antiquity, ancient Greek festivals in honour of the god Hermes or Mercury. One of these was celebrated by the Pheneatæ in Arcadia; a second by the Cyllenians in Elis; and a third by the Tanagræans, where Mercury was represented with a ram upon his shoulder, because he was said to have walked through the city in that posture in time of a plague, and to have cured the sick; in memory of which, it was customary at this festival for one of the most beautiful youths in the city to walk round the walls with a ram upon his shoulder.—A fourth festival of the same name was observed in Crete, when it was usual for the servants to sit down at the table while their masters waited; a custom which was also observed at the Roman Saturnalia.

HERMANN, PAUL, a celebrated botanist, was born at Halle in Saxony, and practised physic in the island of Ceylon, and the Cape of Good Hope, after which (in 1679) he was chosen professor of botany at Leyden, and superintendant of the botanical garden, in which science he obtained the highest reputation, and died in the year 1695. His first publication, in 1687, was a catalogue of plants in the garden of the university,—a garden which, in seven years he had so much enriched with plants from the East and West Indies, that it nearly rivalled the very first in Europe. His method of botanical classification is contained in his *Flora Lugduno-Batava Flores*, published in 1690. His *Paradisus Batavus* &c. was published after his decease, by William Sberard, which contains many rare, and some entirely new species, delineated in a very elegant manner. The rest of Hermann's works are, *Musæi Indici Catalogus, continens varii exotica animalia, insecta, vegetabilia, mineralia; Lapis Lydius Materia Medica*, in which last his new characters of plants are made use of to illustrate their medical properties. At his death he left behind him 450 fine drawings, and a numerous collection of dried plants, which served for the basis of the *Flora Ceylanica* of Linnæus, and also a catalogue of plants of the Cape of Good Hope. Dr Hannes addressed to him a beautiful Latin ode, which is still preserved; but many of the treasures of his industrious life were strangely neglected, and allowed to be dispersed.

HERMANNIA, a genus of plants belonging to the monodelphis class, and in the natural method ranking under the 37th order, *Columnifera*.

HERMANSTADT, a handsome, populous, and strong town of Hungary, capital of Transylvania, with a bishop's see. It is the residence of the governor of the province; and is seated on the river Ceben, in E. Long. 23. 50. N. Lat. 46. 0.

HERMAPHRODITE, is generally understood to

signify a human creature possessed of both sexes, or who has the parts of generation both of male and female. The term however is applied also to other animals, and even to plants.—The word is formed of the Greek *Ἑρμαφροδιτος*, a compound of *Ἑρμης*, Mercury, and *Ἀφροδιτη*, Venus; q. d. a mixture of Mercury and Venus, i. e. of male and female. For it is to be observed, *Hermaphroditus* was originally a proper name, applied by the heathen mythologists to a fabulous deity, whom some represent as a son of *Hermes*, Mercury, and *Aphrodite*, Venus: and who, being desperately in love with the nymph Salmasis, obtained of the god to have his body and hers united into one. Others say, that the god *Hermaphroditus* was conceived as a composition of Mercury and Venus; to exhibit the union between eloquence, or rather commerce, whereof Mercury was god, with pleasure, whereof Venus was the proper deity. Lastly, others think this junction intended to show that Venus (pleasure) was of both sexes; as, in effect, the poet Calvus calls Venus a god.

Pollentemque Deum Venerem.

As also Virgil, *Æneid*, lib. ii.

*Discedo, ac ducente Deo flammam inter et hostes
Expeditor*—————

M. Spon observes, Hesychius calls Venus *Aphroditos*: and Theophrastus affirms, that *Aphroditos*, or Venus, is *Hermaphroditus*; and that in the island of Cyprus she has a statue, which represents her with a beard like a man.—The Greeks also call *hermaphrodites*, *ανδρογυναι*, *androgyni*, q. d. men-women. See the article **ANDROGYNES**.

In a treatise by Mr Hunter, in the 69th volume of the *Philosophical Transactions*, hermaphrodites are divided into *natural* and *unnatural* or monstrous. The first belongs to the more simple orders of animals, of which there are a much greater number than of the more perfect. The unnatural takes place in every tribe of animals having distinct sexes, but is more common in some than in others. The human species, our author imagines, has the fewest; never having seen them in that species, nor in dogs; but in the horse, sheep, and black cattle, they are very frequent.

From Mr Hunter's account, however, it does not appear that such a creature as a perfect hermaphrodite has ever existed. All the hermaphrodites which he had the opportunity of seeing had the appearance of females, and were generally saved as such. In the horse they are very frequent; and in the most perfect of this kind he ever saw, the testicles had come down out of the abdomen into the place where the udder should have been, and appeared like an udder, not so pendulous as the scrotum in the male of such animals. There were also two nipples, of which horses have no perfect form; being blended in them with the sheath or prepuce, of which there was none here. The external female parts were exactly similar to those of a perfect female; but instead of a common-sized clitoris, there was one about five or six inches long: which when erect, stood almost directly backwards.

A foal as very similar to the above was killed, and the following appearances were observed on dissection. The testicles were not come down as in the former,

possibly.

Hermaphrodite.

possibly because the creature was too young. It had also two nipples; but there was no penis passing round the pubes to the belly, as in the perfect male ass. The external female parts were similar to those of the she-ass. Within the entrance of the vagina was placed the clitoris; but much longer than that of a true female, being about five inches long. The vagina was open a little farther than the opening of the urethra into it, and then became obliterated: from thence, up to the fundus of the uterus, there was no canal. At the fundus of the common uterus it was hollow, or had a cavity in it, and then divided into two, viz. a right and a left, called the *horns* of the uterus, which were also pervious. Beyond the termination of the two horns were placed the ovaria, as in the true female; but the Fallopian tubes could not be found.—From the broad ligaments, to the edges of which the horns of the uterus and ovaria were attached, there passed towards each groin a part similar to the round ligaments in the female, which were continued into the rings of the abdominal muscles; but with this difference, that there were continued with them a process or theca of the peritonæum, similar to the tunica vaginalis communis in the male ass; and in these theca were found the testicles, but no vasa deferentia could be observed passing from them.

In most species of animals, the production of hermaphrodites appears to be the effect of chance; but in the black cattle it seems to be an established principle of their propagation. It is a well known fact, and, as far as has yet been discovered, appears to be universal, that when a cow brings forth two calves, one of them a bull, and the other a cow to appearance, the cow is unfit for propagation, but the bull-calf becomes a very proper bull. They are known not to breed; they do not show the least inclination for the bull, nor does the bull ever take the least notice of them. Among the country people in England, this kind of calf is called a *free martin*; and this singularity is just as well known among the farmers as either cow or bull. When they are preserved, it is for the purposes of an ox or spayed heifer; viz. to yoke with the oxen, or fatten for the table. They are much larger than either the bull or the cow, and the horns grow longer and bigger, being very similar to those of an ox. The bellow of a free-martin is also similar to that of an ox, and the meat is finer in the fibre than either the bull or cow; and they are more susceptible of growing fat with good food. By some they are supposed to exceed the ox and heifer in delicacy of taste, and bear a higher price at market; this, however, does not always hold, and Mr Hunter gives an instance of the contrary. The Romans, who called the bull *taurus*, spoke also of *tauræ* in the feminine gender different from cows. Stephens observes, that it was thought they meant by this word *barren cows*, who obtained the name because they did not conceive any more than bulls. He also quotes a passage from Columella, lib. vi. cap. 22. "And, like the *tauræ* which occupy the place of fertile cows, should be rejected or sent away." He likewise quotes Varro, *De re rustica*, lib. ii. cap. 5. "The cow which is barren is called *taura*." From which we may reasonably conjecture, that the Romans had not the idea of the circumstances of their production.

Hermaphrodite.

Of these creatures Mr Hunter dissected three, and the following appearances were observed in the most perfect of them.—The external parts were rather smaller than in the cow. The vagina passed on as in the cow to the opening of the urethra, and then it began to contract into a small canal, which passed on to the division of the uterus into the two horns; each horn passing along the edge of the broad ligament laterally towards the ovaria. At the termination of these horns were placed both the ovaria and testicles, both of which were nearly about the size of a small nutmeg. No Fallopian tubes could be found. To the testicles were vasa deferentia, but imperfect. The left one did not come near the testicle; the right only came close to it, but did not terminate in the body called *epididymis*. They were both pervious, and opened into the vagina near the opening of the urethra.—On the posterior surface of the bladder, or between the uterus and bladder, were the two bags called the *vesicula seminales* in the male, but much smaller than what they are in the bull: the ducts opened along with the vasa deferentia.

Concerning hermaphrodites of the human species, much has been written, and many laws enacted about them in different nations; but the existence of them is still disputed. Dr Parsons has given us a treatise on the subject, in which he endeavours to explode the notion as a vulgar error. According to him, all the hermaphrodites that have appeared, were only women whose clitoris from some cause or other was overgrown; and, in particular, that this was the case with an Angola woman shown at London as an hermaphrodite some time ago.

Among the reptile tribe, indeed, such as worms, snails, leeches, &c. hermaphrodites are very frequent. In the memoirs of the French academy, we have an account of this very extraordinary kind of hermaphrodites, which not only have both sexes, but do the office of both at the same time. Such are earth-worms, round-tailed worms found in the intestines of men and horses, land-snails, and those of fresh-waters, and all the sorts of leeches. And, as all these are reptiles, and without bones, M. Poupert concludes it probable, that all other insects which have these two characters are also hermaphrodites.

The method of coupling practised in this class of hermaphrodites, may be illustrated in the instance of earth-worms. These little creatures creep, two by two, out of holes proper to receive them, where they dispose their bodies in such a manner, as that the head of the one is turned to the tail of the other. Being thus stretched lengthwise, a little conical button or papilla is thrust forth by each, and received into an aperture of the other. These animals, being male in one part of the body, and female in another, and the body flexible withal, M. Homberg does not think it impossible but that an earth-worm may couple with itself, and be both father and mother of its young; an observation which, to some, appears highly extravagant.

Among the insects of the soft or boneless kind, there are great numbers indeed, which are so far from being hermaphrodites, that they are of no sex at all. Of this kind are all the caterpillars, maggots, and worms, produced of the eggs of flies of all kinds: but the reason

Hermaphrodite of this is plain; these are not animals in a perfect state, but disguises under which animals lurk. They have no business with the propagating of their species, but are to be transformed into animals of another kind, by the putting off their several coverings, and then only they are in their perfect state, and therefore then only shew the differences of sex, which are always in the distinct animals, each being only male or female. These copulate, and their eggs produce these creatures, which show no sex till they arrive at that perfect state again.

HERMAPHRODITE Flowers, in *Botany*. These are so called by the sexualists on account of their containing both the antheræ and stigma, the supposed organs of generation, within the same calyx and petals. Of this kind are the flowers of all the classes in Linnæus's sexual method, except the classes *montecia* and *diœcia*; in the former of which, male and female flowers are produced on the same root; in the latter, in distinct plants from the same seed.—In the class *polygamia*, there are always hermaphrodite flowers mixed with male or female, or both, either on the same or distinct roots. In the plantain-tree the flowers are all hermaphrodite; in some, however, the antheræ or male organ, in others the stigma or female organ, proves abortive. The flowers in the former class are styled *female hermaphrodites*; in the latter, *male hermaphrodites*.—Hermaphrodites are thus as frequent in the vegetable kingdom as they are rare and scarce in the animal one.

HERMAS, an ecclesiastical author of the first century; and according to Origen, Eusebius, and Jerome, the same whom St Paul salutes in the end of his epistle to the Romans. He wrote a book in Greek some time before Domitian's persecution, which happened in the year 95. This work is entitled *The Pastor*, from his representing an angel speaking to him in it under the form of a shepherd. The Greek text is lost, but a very ancient Latin version of it is still extant. Some of the fathers have considered this book as canonical. The best edition of it is that of 1698, where it is to be found among the other apostolical fathers, illustrated with the notes and corrections of Cotelerius and Le Clerc. With them it was translated into English by Archbishop Wake, the best edition of which is that of 1710.

HERMAS, a genus of plants belonging to the polygamia class. See *BOTANY Index*.

HERMES, or **HERMA**, among antiquaries, a sort of square or cubical figure of the god Mercury, usually made of marble, though sometimes of brass or other materials, without arms or legs, and planted by the Greeks or Romans in their cross-ways.

Servius gives us the origin thereof, in his comment on the eighth book of the *Æneid*. Some shepherds, says he, having one day caught Mercury, called by the Greeks *Hermes*, asleep on a mountain, cut off his hands; from which he, as well as the mountain where the action was done, became denominated Cyllenius, from *κύλλης*, *maimed*: and thence, adds Servius, it is that certain statues without arms are denominated *Hermeses* or *Hermæ*. But this etymology of the epithet of Cyllenius contradicts most of the other ancient authors; who derive it hence, that Mercury was born at Cyllene a city

of Elis, or even on the mountain Cyllene itself, which had been thus called before him.

Suidas gives a moral explication of this custom of making statues of Mercury without arms. The *Hermeses*, says he, were statues of stone placed at the vestibules or porches of the doors and temples at Athens; for this reason, that as Mercury was held the god of speech and of truth, square and cubical statues were peculiarly proper; having this in common with truth, that on what side soever they are viewed, they always appear the same.

It must be observed, that Athens abounded more than any other place in *Hermeses*: there were abundance of very signal ones in divers parts of the city, and they were indeed one of the principal ornaments of the place. They were also placed in the high-roads and cross-ways, because Mercury, who was the courier of the gods, presided over the high-ways; whence he had his surname of *Trivius*, from *trivium*; and that of *Vivæus*, from *vivæ*.

From Suidas's account, above cited, it appears, that the *termini*, used among us in the door-ways, balconies, &c. of our buildings, take their origin from these Athenian *Hermeses*, and that it was more proper to call them *hermetes* than *termini*, because though the Roman *termini* were square stones, whereon a hand was frequently placed, yet they were rather used as land-marks and mere stones than as ornaments of building. See the articles **MERCURY** and **THOTH**.

HERMETIC, or **HERMETICAL Art**, a name given to chemistry, on a supposition that Hermes Trismegistus was the inventor thereof, or that he excelled therein. See **THOTH**.

HERMETICAL Philosophy is that which undertakes to solve and explain all the phenomena of nature, from the three chemical principles, salt, sulphur, and mercury.

HERMETICAL Physic, or **Medicine**, is that system or hypothesis in the art of healing, which explains the causes of diseases, and the operations of medicine, on the principles of the hermetical philosophy, and particularly on the system of alkali and acid.

HERMETICAL Seal, a manner of stopping or closing glass vessels, for chemical operations, so very accurately, that nothing can exhale or escape, not even the most subtle spirits. It is performed by heating the neck of the vessel in the flame of a lamp till it be ready to melt, and then with a pair of pincers twisting it close together. This they call putting on *Hermes's seal*. There are also other ways of sealing vessels hermetically; viz. by stopping them with a plug or stopple of glass, well luted into the neck of the vessel; or by turning another ovum philosophicum upon that wherein the matter is contained.

HERMHARPOCRATES, or **HERMARPOCRATES**, in antiquity, a deity, or figure of a deity, composed of Mercury, and Harpocrates the god of Silence.

M. Spon gives us a *hermharpocrates* in his *Rech. Cur. de l'Antiquité*, p. 98. fig. 15. having wings on his feet like Mercury, and laying his finger on his mouth like Harpocrates. It is probable they might mean, by this combination, that silence is sometimes eloquent.

HERMIANI,

HERMIANI, or **HERMIATITÆ**, a sect of heretics in the second century, thus called from their leader Hermias. They were also denominated *Seleuciani*.

One of their distinguishing tenets was, that God is corporeal. Another, that Jesus Christ did not ascend into heaven with his body, but left it in the sun.

HERMIONE, in *Ancient Geography*, a considerable city of Argolis. It was in ruins (except a few temples) in the time of Pausanias; who says that the new city was at the distance of four stadia from the promontory on which the temple of Neptune stood. It gave name to the Sibus Hermionicus, a part of the Sibus Argolicus.

HERMIT, or **EREMIT**, *Eremita*, a devout person retired into solitude, to be more at leisure for prayer and contemplation, and to disencumber himself of the affairs of this world.—The word is formed from the Greek *eremos*, *desert* or *wilderness*; and according to the etymology, should rather be wrote *Eremit*.

Paul surnamed the *Hermit*, is usually reckoned the first hermit; though St Jerome at the beginning of the life of that saint says, it is not known who was the first.—Some go back to John the Baptist, others to Elias: others make St Anthony the founder of the eremitical life; but others think that he only rekindled and heightened the fervour thereof, and hold that the disciples of that saint owned St Paul of Thebes for the first that practised it. The persecutions of Decius and Valerian are supposed to have been the occasion.—Several of the ancient hermits, as St Anthony, &c. though they lived in deserts, had yet numbers of religious accompanying them.

There are also various orders and congregations of religious distinguished by the title of *hermits*; as, hermits of St Augustine, of St John Baptist, of St Jerome, of St Paul, &c.

HERMIT, *the*, *Peter Gautier*, a French officer of Amiens in Picardy, who quitted the military profession, and commenced hermit and pilgrim. He travelled to the Holy Land about the year 1093; and making a melancholy recital of the deplorable situation of a few Christians in that country to Pope Urban II. and at the same time enthusiastically lamenting that Infidels should be in possession of the famous city where the Author of Christianity first promulgated his sacred doctrines, Urban gave him a fatal commission to excite all Christian princes to a general war against the Turks and Saracens the possessors of the Holy Land. See **CROISADE**.

HERMITAGE properly signifies a little hut or habitation, in some desert place, where a hermit dwells.

Hermitage is also popularly attributed to any religious cell, built and endowed in a private and recluse place, and thus annexed to some large abbey, of which the superior was called *hermita*.

HERMODACTYL, in the *Materia Medica*, a root brought from Turkey. It is of the shape of a heart flatted, of a white colour, compact, yet easy to be cut or powdered; of a viscous sweetish taste, with a light degree of acrimony. Hermodactyls were of great repute among the ancients as a cathartic; but those we now meet with in the shops have very little purgative virtue; Neumann declares he never found them to have any effect at all.—The hermodactyl is the root of the col-

chicum variegatum, according to some; others suppose it to be the root of the iris tuberosa.

HERMOGENES, the first and most celebrated architect of antiquity, was, according to Vitruvius, born at Alanbada, a city in Caria. He built a temple of Diana at Magnesia; another of Bacchus at Tros; and was the inventor of several parts of architecture. He composed a book on the subject, which is lost.

HERMOGENES Tarsensis, a rhetorician and orator, and who was in every respect a prodigy. At 17 years of age he published his system of rhetoric, and at 20 his philosophic ideas: but at 25 he forgot every thing he had known. It is said that his body being opened after his death, his heart was found of an extraordinary size, and all over hairy. He died about 168 B. C.

HERMOGENIANS, a sect of ancient heretics, denominated from their leader Hermogenes, who lived towards the close of the second century. Hermogenes established matter as his first principle; and regarding matter as the fountain of all evil, he maintained that the world, and every thing contained in it, as also the souls of men and other spirits, were formed by the Deity from an uncreated and eternal mass of corrupt matter. The opinions of Hermogenes, with regard to the origin of the world and the nature of the soul, were warmly opposed by Tertullian.

The Hermogenians were divided into several branches under their respective chieftains, viz. Hermiani, Seleucians, Materiari, &c.

HERMON, or **AERMON**, in *Ancient Geography*, a mountain of the Amorites, called *Sanior* by the Phœnicians, and *Sanir* or *Senir* by the Amorites, on the east of Jordan. It is also called *Sion*, (Moses); but must not be confounded with the Sion of Jerusalem. By the Sidonians it was called *Scirion*; in the vulgate, it is called *Sarion*. Joshua informs us, that it was the dominion of Og king of Bashan; which must be understood of its south side. It is never particularly mentioned by profane writers; being comprised under the appellation *Libanus*, or *Antilibanus*, with which mountain it is joined to the east. It is also called *Hermonium* plurally, Psalm xlii. 6. because it was extensive, and contained several mountains.

HERMOPOLIS, in *Ancient Geography*, the name of several cities in Egypt, dedicated, as the name imports, to Hermes or Mercury. Near one of these cities, probably Hermopolis Magna, was situated a most magnificent temple, of which the portico only now remains. It was visited by Denon who accompanied the French army in their expedition to Egypt, in 1799; and he describes it as a most beautiful monument of ancient architecture, and a splendid relic of the highest antiquity. Among the hillocks within 300 or 400 yards of the portico, enormous blocks of stone are seen buried in sand, and regular architecture beneath them, which appear to form an edifice containing columns of granite, just rising above the present level of the soil. Every part of this edifice is covered with hieroglyphics. Connected with the scattered fragments of the great temple, a mosque has been built, in which is a number of columns of cipoline marble. Near this is the village of Achmunin, which contains 5000 inhabitants.

HERMUS, in *Ancient Geography*, a river of Ionia; which

which rising near Dorylæum, a town of Phrygia, in a mountain sacred to Dindymene or Cybele, touched Mysia, and ran through the Regio Combusta, then through the plains of Smyrna down to the sea, carrying along with it the Pactolus, Hyllus, and other less noble rivers. Its waters were said, by Virgil and other poets, to roll down gold.

HERNANDRIA, JACK-IN-A-BOX-TREE; a genus of plants belonging to the monœcia class; and in the natural method ranking under the 38th order, *Tricocœ*. See **BOTANY Index**.

HERNE, a town of Kent, six miles from Canterbury, 12 from Margate, and 14 from Feversham. The church is a large ancient structure, with a tower of flint, and has six stalls of the cathedral kind, with divisions of the choir from the nave by a carved screen of oak. The church is 113 feet long. The stone front is very ancient. Here the great Dr Ridley, the English martyr, was vicar. Here is a commodious bay, frequented by colliers, &c.

HERNIA, in *Medicine and Surgery*, a descent of the intestines or omentum out of their natural place; or rather, the tumour formed by that descent, popularly called a rupture. The word is Latin, *hernia*, and originally signifies the same with *tumor scroti*, called also *ramex*. Priscian observes, that the ancient Marsi gave the appellation *hernia* to rocks: whence some will have hernias thus called *propter duritiem*, on account of their hardness. Scaliger chooses rather to derive the word from the Greek *ἄρα*, *ramus*, branch. See **SURGERY Index**.

HERNIARIA, RUPTURE-WORT, a genus of plants belonging to the pentandria class; and in the natural method ranking under the 11th order, *Sarmentaceæ*. See **BOTANY Index**.

HERO, in Pagan mythology, a great and illustrious person, of a mortal nature, though supposed by the populace to partake of immortality, and after his death to be placed among the number of the gods. The word is formed of the Latin *heros*, and that of the Greek *ἡμιθεός*, *semi-deus*, "demi-god."—The Greeks erected columns and other monuments over the tombs of their heroes, and established a kind of worship in honour of the manes both of their heroes and heroines. The Romans also raised statues in honour of their heroes; but there were six of their heroes of a superior order, and who were supposed to be admitted into the community of the twelve great gods: these were Hercules, Bacchus, Esculapius, Romulus, Castor, and Pollux. Writers have distinguished between the worship which the ancients paid to their heroes and that offered to their gods. The latter, it is said, consisted of sacrifices and libations; the former was only a kind of funeral honour, in which they celebrated their exploits, concluding the rehearsal with feasts.

HERO is also used in a more extensive sense, for a great, illustrious, and extraordinary personage: particularly in respect of virtues.

F. Bouhours makes this distinction between a great man and a hero, that the latter is more daring, fierce, and enterprising: and the former more prudent, thoughtful, and reserved. In this sense we properly say, Alexander was a hero, Julius Cæsar a great man.

HERO of a poem or romance, is the principal personage, or he who has the chief part in it. Thus the

hero of the Iliad is Achilles; of the Odyssey, Ulysses; of the Æneid, Æneas; of Tasso's Jerusalem, Godfrey of Boulogne; of Milton's Paradise Lost, Adam; though Mr Dryden will have the devil to be Milton's hero, because he gets the better of Adam, and drives him out of Paradise.

HERO, in fabulous history, a famous priestess of Venus, lived at Abydos, in a tower situated on the banks of the Hellespont. She being beloved by Leander, who lived at Sestos on the other side of the strait, he every night swam over to visit her, being directed by a light fixed on the tower. But the light being put out in a stormy night, the youth missed his way and was drowned; on which Hero threw herself into the sea, and perished.

HERO, the name of two celebrated Greek mathematicians; the one called the *old*, and the other the *young*, *Hero*. The younger was a disciple of Ctesibius. They are known by two works translated into Latin by Barochius; *Spiralium liber*, by Hero senior; and *Tractat. artis et machin. militar.* by Hero junior. They flourished about 130 and 100 B. C.

HEROD, surnamed the Great, was born about 71 years before the commencement of the Christian era. When about 25 years of age, his father Antipater made him governor of Galilee, where he distinguished himself by suppressing a band of robbers, and executing their ringleader. For this action, as it was performed by his own authority, and without trial of the criminals, he was ordered to appear before the sanhedrim; but by the influence of his party and the favour of the high priest, he escaped judgment. During the civil war between the republican and Cæsarian parties, Herod joined Cassius, and was made governor of Cœle-syria. He caused Malichus to be assassinated for having poisoned his father, and ingratiated himself with Mark Antony. After being an exile for some time in Egypt, he found means to arrive at Rome, where Antony received him with great kindness, and the senate made choice of him to the crown of Judea, about 40 years before the birth of Christ. It was in the possession of Antigonus at that time, and he had consequently to fight his way to it. He was finally victorious, Antigonus was taken prisoner, and Herod succeeded to the regal dignity in the year 37 before Christ. In filling his empty coffers he was guilty of many cruel extortions, and it is but justice to add, that he performed many acts of clemency. He sent for the aged high priest Hyrcan, who had been deposed, and treated him with the greatest kindness, and raised Aristobulus, the brother of his beloved Mariamne, to the pontifical dignity. Soon after, indeed, from a fit of jealousy, he caused him to be drowned in a bath. He was accused to Antony by his mother-in-law, and he appointed his uncle Joseph to govern in his absence, charging him to put the queen to death, if his trial should prove fatal to him, as he could not support the idea of her falling into the possession of another.

Herod received a visit from Cleopatra, who is reported to have had amorous intentions with regard to him, which he prudently disappointed, for fear of the vengeance of Antony; but he fully satisfied her avarice with the most ample donations. When hostilities commenced between Antony and Octavius, he raised an army to join the former, but had first to contend with

Herod. Mithribus, king of part of Arabia, whom he defeated, and compelled to sue for peace. After the battle of Actium, he resolved to make terms with the victor, to prepare for which he put the aged Hyrcan to death, and embarked for Rhodes, where Augustus at that time was. He appeared before the emperor in all the insignia of royalty except his diadem, boldly relating all the services he had performed to his benefactor Antony, and observed that he was willing to transfer the same gratitude to a new patron, from whom he might hold his crown and kingdom.

Augustus was struck with the magnanimity of this defence, and replaced the diadem on his head. When Augustus passed through Syria in his way to and from Egypt, he was magnificently entertained by Herod, for which he restored him the whole of his dominions, and even enlarged them. Before his interview with Augustus, Herod had given a second order respecting the murder of Mariamne; and growing jealous of Sohemus, her last guardian, he soon after had her condemned and executed, in spite of the solemn protestations of her innocence. His remorse on this occasion was dreadful, and no scenes of riot or debauchery could banish her from his mind. He would frequently call aloud upon her name, and order his attendants to bring her into his presence, as if unwilling to forget that she was no more. He built a theatre and amphitheatre at Jerusalem, for the purpose of celebrating games in honour of Augustus, which exasperated the Jews to such a degree, that a conspiracy was formed against him, and on the detection of it, the principal contrivers were punished with a merciless severity.

He built several strong fortresses in different parts of Judea, for his own security, one of which, in honour of the emperor, was denominated Cæsarea. To supply in some measure the loss of Mariamne, he married another lady of the same name, the beautiful daughter of a priest, whom he raised to the supreme pontificate. He was in such favour with Augustus, that he was appointed imperial procurator of Syria, and obtained a tetrarchy for his brother. To conciliate the favour of the Jews, he undertook the vast work of rebuilding the temple of Jerusalem, and by constantly employing a whole army of workmen for a year and a half, this magnificent edifice was completed. In the course of another visit to the emperor, Herod obtained new favours, particularly a grant of half the produce of the mines of Cyprus, and the overseership of the rest. After this he dedicated his new city of Cæsarea, when he exhibited so much profuse magnificence, that Augustus said, his soul was too great for his kingdom. He procured the condemnation and the death of his two sons by the first Mariamne, for which he has been bitterly accused; but when we recollect that he took the greatest care of the two sons whom each left behind him, we much conclude that there was more reason for their punishment than some are willing to allow. The charge brought against them was an unnatural conspiracy against his life and crown, and it seems to have been fairly substantiated. His ungrateful brother Pheroras, and his favoured son Antipater conspired against him. Soon after the discovery of it the former died, and the latter went to Rome.

The birth of Christ happened in the 33d year of his reign, which is said to have been soon followed by that

act of barbarous cruelty, the massacre of the children of Bethlehem, instigated by jealousy of this king of the Jews in a spiritual sense, of whose birth he obtained information from the magi. It is to be observed that the account of this deed is no where to be met with but in St Matthew's gospel, for while Josephus seems to dwell with studied minuteness on the cruelties of Herod, he gives not a single hint respecting this massacre. As Antipater was returning from Rome, he was arrested by his father's orders, tried and condemned for treasonable practices. These calamities, joined to a shattered constitution, threw Herod into a loathsome distemper, accompanied with remarkable symptoms, which has sometimes been considered as a judgment from heaven. He ordered the sentence against Antipater to be put in execution, and appointed his son Archelaus to succeed him on the throne. According to Josephus, he collected together at Jericho the chief persons among the Jews, where he ordered them to be shut up in the circus, giving strict orders to his sister Salome to have them all massacred as soon as he breathed his last. This order was never executed, but we very much doubt the veracity of Josephus whether it was ever given. The most bloody monster that ever existed, was chiefly pleased with such acts of cruelty as he could either perform in person, witness by the agency of his slaves, or know to be done during his lifetime; but this supposed posthumous cruelty of Herod is wholly unaccountable. If it was actually the case, we can account for it upon no principles of human depravity, and it is wholly *unique* in the annals of tyranny.

His remains were interred with great pomp and magnificence; and although his memory has been consigned to detestation and abhorrence, his great talents and the glories of his reign, conspire to assign him a distinguished place in the list of sovereigns.

HERODIAN, an eminent Greek historian, who spent the greatest part of his life at Rome, flourished in the third century, in the reigns of Severus, Caracalla, Heliogabalus, Alexander, and Maximin. His history begins from the death of Marcus Aurelius the Philosopher; and ends with the death of Balbinus and Maximin, and the beginning of the reign of Gordian. It is written in very elegant Greek; and there is an excellent translation of it into Latin, by Angelus Politianus. Herodian has been published by Henry Stephens in 4to, in 1581; by Boecker, at Strasburg, in 1662, 8vo; and by Hudson, at Oxford, in 1699, 8vo.

HERODIANS, a sect among the Jews at the time of our Saviour: mentioned Matth. xxii. 16. Mark iii. 6.

The critics and commentators are very much divided with regard to the Herodians. St Jerome, in his Dialogue, against the Luciferians, takes the name to have been given to such as owned Herod for the Messiah; and Tertullian and Epiphanius are of the same opinion. But the same Jerome, in his Comment on St Matthew, treats his opinion as ridiculous; and maintains, that the Pharisees gave this appellation by way of ridicule to Herod's soldiers who paid tribute to the Romans; agreeable to which the Syrian interpreters render the word by *the domestics of Herod*, i. e. "his courtiers." M. Simon, in his notes on the 22d chapter of Matthew, advances a more probable opinion.

The

Herodians, Herodotus. The name *Herodian* he imagines to have been given to such as adhered to Herod's party and interest; and were for preserving the government in his family, about which were great divisions among the Jews.—F. Hardouin will have the Herodians and Sadducees to have been the same.—Dr Prideaux is of opinion that they derived their name from Herod the Great, and that they were distinguished from the other Jews by their concurrence with Herod's scheme of subjecting himself and his dominions to the Romans, and likewise by complying with many of their heathen usages and customs. This symbolizing with idolatry upon views of interest and worldly policy, was probably that leaven of Herod, against which our Saviour cautioned his disciples. It is farther probable that they were chiefly of the sect of Sadducees; because the leaven of Herod is also denominated the leaven of the Sadducees.

HERODOTUS, an ancient Greek historian of Halicarnassus in Caria, son of Lyxus and Dryo, was born in the first year of the 74th Olympiad, that is, about 484 B. C. The city of Halicarnassus being at that time under the tyranny of Lygdamis grandson of Artemisia queen of Caria, Herodotus quitted his country and retired to Samos; from whence he travelled over Egypt, Greece, Italy, &c. and in his travels acquired the knowledge of the history and origin of many nations. He then began to digest the materials he had collected into order, and composed that history which has preserved his name among men ever since. He wrote it in the isle of Samos, according to the general opinion.—Lucian informs us, that when Herodotus left Caria to go into Greece, he began to consider with himself

What he should do to be for ever known,
And make the age to come his own,

in the most expeditious way, and with as little trouble as possible. His history, he presumed, would easily procure him fame, and raise his name among the Grecians in whose favour it was written; but then he foresaw that it would be very tedious to go through the several cities of Greece, and recite it to each respective city; to the Athenians, Corinthians, Argives, Lacedæmonians, &c. He thought it most proper therefore to take the opportunity of their assembling all together; and accordingly recited his work at the Olympic games, which rendered him more famous than even those who had obtained the prizes. None were ignorant of his name, nor was there a single person in Greece who had not seen him at the Olympic games, or heard those speak of him who had seen him there.

His work is divided into nine books; which according to the computation of Dionysius Halicarnassensis, contain the most remarkable occurrences within a period of 240 years; from the reign of Cyrus the first king of Persia, to that of Xerxes when the historian was living. These nine books are called after the names of the nine muses, each book being distinguished by the name of a muse; and this has given birth to two disquisitions among the learned: 1. Whether they were so called by Herodotus himself; and, 2. For what reason they were so called. As to the first, it is generally agreed that Herodotus did not impose these

names himself; but it is not agreed why they were imposed by others. Lucian tells us, that these names were given them by the Grecians at the Olympic games, when they were first recited, as the best compliment that could be paid the man who had taken pains to do them so much honour. Others have thought that the names of the *muses* have been fixed upon them by way of reproach; and were designed to intimate, that Herodotus, instead of true history, had written a great deal of fable. But, be this as it will, it is certain, that with regard to the truth of his history, he is accused by several authors; and, on the other hand, he has not wanted persons to defend him. Aldus Manutius, Joachim Camerarius, and Henry Stephens, have written apologies for him; and, among other things, have very justly observed, that he seldom relates any thing of doubtful credit without producing the authority on which his narration is founded; and, if he has no certain authority to fix it upon, uses always the terms *ut ferunt, ut ego audivi, &c.*

There is ascribed also to Herodotus, but falsely, a Life of Homer, which is usually printed at the end of his work.—He wrote in the Ionic dialect, and his style and manner have ever been admired by all people of taste. There have been several editions of the works of this historian; two by Henry Stephens, one in 1570, and the other in 1592; one by Gale at London in 1679; and one by Gronovius at Leyden in 1715, which is the last and best, though not the best printed.

HEROIC, something belonging to a hero, or heroine. Thus we say, *heroic actions, heroic virtues, heroic style, heroic verse, heroic poet, heroic age, &c.*

HEROIC AGE, is that age or period of the world wherein the *heroes*, or those called by the poets the *children of the gods*, are supposed to have lived.—The heroic age coincides with the fabulous age.

HEROIC POEM, is that which undertakes to describe some extraordinary action or enterprise. Homer, Virgil, Statius, Lucan, Tasso, Camoens, Milton, and Voltaire, have composed *heroic poems*. In this sense, *heroic poem* coincides with *epic poem*.

HEROIC VERSE, is that wherein heroic poems are usually composed; or, it is that proper for such poems. In the Greek and Latin, hexameter verses are peculiarly denominated *heroic verses*, as being alone used by Homer, Virgil, &c. Alexandrine verses, of 12 syllables, were formerly called *heroic verses*, as being supposed the only verse proper for heroic poetry; but later writers use verses of ten syllables.

HEROINE, HEROINA, or Herois, a woman that has the qualities and virtues of a hero, or that has done some heroic action.

HERON. See ARDEA, ORNITHOLOGY *Index*.

This bird is a very great devourer of fish, and will do more mischief to a pond than even an otter. Some say that an heron will destroy more fish in a week than an otter will in three months; but that seems carrying the matter too far. People who have kept herons, have had the curiosity to number out the fish they fed them with into a tub of water; and counting them again afterwards, it has been found that a heron will eat 50 moderate-sized dace and roaches in a day. It has been found, that in carp-ponds visited by this bird, one heron will eat up 1000 store carp in a year, and

Heron will host them so close that very few can escape. The readiest method of destroying this mischievous bird is by fishing for him in the manner of pike, with a baited hook; the bait consisting of small roach or dace, and the hook fastened to one end of a strong line, made of silk and wire twisted together. To the other end of the line is fastened a stone of a pound weight; and several of these baited lines being sunk by means of the stone in different parts of the pond, in a night or two the heron will not fail of being taken by one or other of them.

HERPES, in *Medicine*, a bilious pustule, which breaking out in different manners upon the skin, accordingly receives different denominations. See *ME-DICINE Index*.

HERRERA TORDESILLAS, ANTHONY, a Spanish historian, the son of Roderic de Tordesillas and Agnes de Herrera, it being the custom of that country to bear the mother's name, was born in 1565. He was secretary to Vespasian de Gonzaga, viceroy of Navarre and Valentia, and afterwards appointed royal historiographer for the Indies by Philip II. to which a liberal pension was attached. While he held this office, he wrote his general history of the Indies in 4 vols folio, comprehending the whole of the Spanish transactions there, from 1492 to 1554. The celebrated Scottish historian Dr Robertson, says of it, that it "furnishes the fullest and most accurate information concerning the conquest of Mexico, as well as every other transaction of America. The industry and attention with which he consulted not only the books, but the original and public records were so great, and he usually judges of the evidence before him with so much impartiality and candour, that his decads may be ranked among the most judicious and useful historical collections." Herrera likewise composed a general history of his own time, from 1554 to 1598, which is not so much admired. His death, which happened in 1625, prevented him from enjoying the office of secretary of state, which Philip IV. designed for him on the very first vacancy.

HERRERA, Ferdinand de, a Spanish poet of the 16th century, was a native of Seville. In the year 1582, he published a collection of poems of the lyric and heroic species, which were reprinted in 1619. By these he obtained a considerable reputation as a favourite of the muses, and made him be regarded as the first lyric poet belonging to Spain. As to his style, it is generally allowed to be neat, elegant, copious, and correct. He likewise published an edition of Garcilasso de la Vega, with notes; a narrative of the war with Cyprus, and of the battle of Lepanto.

HERRING, in *Ichthyology*, a species of *CLUPEA*.

The name *herring* is derived from the German *heer*, an *army*, which expresses their number, when they migrate into our seas. Herrings are found in great plenty from the highest northern latitudes as low as the northern coasts of France. They are also met with in vast shoals on the coast of America, as low as Carolina: they are found also in the sea of Kamtschatka, and possibly reach Japan: but their winter rendezvous is within the arctic circle, whither they retire after spawning, and where they are provided with plenty of insect food. For an account of the remarkable migration of herrings, and the history of the fishery, &c. see *CLUPEA* and *Herring-FISHERY*.

They are in full roe at the end of June, and continue in perfection till the beginning of winter, when they begin to deposit their spawn.

There are different names given to preserved herrings, according to the different manners wherein they are ordered: as, 1. *Sea-sticks*; which are such as are caught all the fishing season, and are but once packed. A barrel of these holds six or eight hundred; eight barrels go to the ton by law; a hundred of herrings is to be a hundred and twenty; a last is ten thousand, and they commonly reckon fourteen barrels to the last. 2. There are others, repacked on shore, called *repacked herrings*; seventeen barrels of sea-sticks commonly make from twelve to fourteen of repacked herrings. The manner of repacking them is, to take out the herrings, wash them out in their own pickle, and lay them orderly in a fresh barrel: these have no salt put to them, but are close packed, and headed up by a sworn cooper, with pickle, when the barrel is half full. The pickle is brine; so strong as that the herring will swim in it. 3. *Summers*, are such as the Dutch chasers or divers catch from June to the 15th of July. These are sold away in sea-sticks, to be spent presently, in regard of their fatness; because they will not endure repacking. They go one with another, full and shotten; but the repacked herrings are sorted, the full herrings by themselves. 4. The *shotten* and *sick herrings* by themselves; the barrel whereof is to be marked distinctly. 5. *Crux herrings*; which are such as are caught after the 14th of September. These are cured with that kind of salt called salt upon salt, and are carefully sorted out, all full herrings, and used in the repacking. 6. *Corved herrings*. These serve to make red herrings, being such as are taken in the Yarmouth seas, from the end of August to the middle of October; provided they can be carried ashore within a week, more or less, after they are taken. These are never gipped but rowed in salt, for the better preserving of them, till they can be brought on shore; and such as are kept to make *red herrings* are washed in great vats in fresh water, before they are hung up in the *herring-hangs* or *red-herring* houses.

As for the *manner of salting herrings*. The nets being haled on board, the fishes are taken out, and put into the warbacks, which stand on one side of the vessel. When all the nets are thus unloaded, one fills the gippers baskets. The gippers cut their throats, take out their guts, and fling out the full herrings into one basket, and the shotten into another. One man takes the full basket when they are gipped, and carries them to the rower-back, wherein there is salt. One boy rows and stirs them about in the salt, and another takes them; thus rowed, and carries them in baskets to the packers. Four men pack the herrings into one barrel, and lay them, one by one, straight and even; and another man, when the barrel is full, takes it from the packers. It is left to stand a day, or more, open to settle, that the salt may melt and dissolve to pickle; after which it is filled up, and the barrel headed. The pickle is to be strong enough to sustain a herring; otherwise the fish decay in it.

HERRING, Thomas, archbishop of Canterbury, memorable for his attachment to civil and religious liberty, was the son of a clergyman, and born in the year 1693. He received his grammar-school education at

Wisbech

Herring.

Wisbech in the isle of Ely; and at the age of 17 was sent to Jesus college in the university of Cambridge, at which place he was made B. A. in 1714, and the title or degree of A. M. was conferred upon him about three years afterwards. In the year 1722, he was appointed chaplain to Dr Fleetwood, bishop of Ely, who gave him two rectories; and in 1726 he was nominated preacher to the honourable society of Lincoln's Inn. He was chosen chaplain in ordinary to his majesty about the same period, and obtained from Cambridge the degree of D. D. in the year 1728. Bishop Fleetwood, his worthy patron, declared to his friends, that he never heard a sermon from Dr Herring which he would not have been proud to be the author of himself. In 1731, he was chosen rector of Blechingley in Surrey; the same year appointed dean of Rochester, and the king promoted him to the see of Bangor in the year 1737. He was appointed archbishop of York in 1743; and it was peculiarly fortunate for the country at that critical juncture, that a man of his principles and public spirit was raised to such an exalted rank. The rebellion in Scotland was so artfully concealed by its friends in England, that it was scarcely believed the Highlanders were in arms, till the royalists were defeated at the battle of Prestonpans. Amidst the universal consternation which this event occasioned, Archbishop Herring roused the people to a sense of their danger, contributed to remove the panic, and encouraged them to unite with firmness and vigour in the defence of their country.

A meeting of the nobility, gentry, and clergy, was held at York, where the archbishop addressed them in a very able and animated speech, requesting them to unite as one man in averting the present danger, to preserve their happy constitution, and contribute to a subscription for raising troops in defence of the country. The whole assembly entered warmly into his views, and immediately subscribed about 40,000*l.* for the important purpose recommended by his grace. On the death of Archbishop Potter, which happened in 1747, Dr Herring was translated to the see of Canterbury. In 1753 he was seized with a violent fever, which brought him to the verge of the grave; and although he so far recovered that he languished for a few years, yet his strength and spirits were very much exhausted, and he expired in 1756, in the 63d year of his age. He was buried, according to his own desire, without any pomp or parade, and no monument was erected to his memory.

We are informed by Mr Duncombe, that the archbishop's person was tall and comely; his constitution, from his tenderest youth, weak and delicate; his address easy, engaging, and polite. He was generous without prodigality, magnificent without profusion, and humble without meanness. In his life-time he could never be prevailed upon to publish any of his sermons; but after his death Mr Duncombe published seven sermons on public occasions, in one volume octavo, giving in the preface some account of the author's life. In the Monthly Review he was termed "a prelate of uncommon virtues, a man of extraordinary accomplishments, a candid divine, a polite scholar, a warm lover of his country, a true friend to liberty, religious as well as civil, and of course, a most sincere hater of persecution."

Herrnhut.

HERRNHUT, or HERRNHUTH, the first and most considerable settlement of the United Brethren, commonly called *Moravians*, situated in Upper Lusatia, upon an estate belonging to the family of Nicholas Lewis Count Zinzendorf, about 50 miles east of Dresden. See the article *UNITED Brethren*.

The building of this place was begun in 1727 by some emigrants from Moravia, who forsook their possessions on account of the persecution they suffered as Protestants from the Roman Catholics; and being well received by Count Zinzendorf, cleared a spot of ground allotted to them by him upon the rise of an hill called the *Hutberg*, or Watch-hill, from which they took occasion to call the new settlement *Herrnhut*, or the Watch of the Lord. More emigrants taking refuge with them, and many other persons joining their congregation, the buildings increased considerably; and at present Herrnhut is a regular and well-built village, containing about 1300 inhabitants, all members of the Church of the United Brethren. Besides the minister and his assistants, a warden is appointed, who presides in the vestry, and superintends the temporal concerns of the settlement. The Brethren distinguish themselves by a plain and uniform dress, the women having retained the dress of the countries from which the first emigrants proceeded, not from any superstitious attachment to old forms, but from a desire to preclude vanity and useless expence. As most of the settlements of this community resemble each other, both in the disposition of their buildings and in their internal regulations, we will give a short sketch of Herrnhut, as the pattern from which the rest were copied, though there are others in which the buildings are more regularly planned. The chapel, which is situated in a large square, is a spacious and neat building, furnished with a good organ and moveable forms, but no pews. The men sit on one side, and the women on the other, entering at separate doors. Besides the usual Sunday's service, the congregation meets here every evening and the children every morning. The dwelling of the minister and warden of the congregation form one, and a school-house the other, wing to the chapel. From the chapel an avenue of trees leads to the burying ground, which is a large square field on the declivity of the Hutberg, and at some distance from the village. Several walks bordered by trees, and furnished with seats, surround and intersect it. The grave-stones and graves are all of equal size, and placed in regular rows; only the vault of Count Zinzendorf, as lord of the manor, is larger than the rest. Burials are performed with great solemnity, but no mourning dresses used.—On one side of the square, in which the chapel stands, is a large building, inhabited by the single men, with workshops, outhouses, and gardens, exclusive of the dwelling rooms. The main building contains a neat chapel, in which a short morning and evening service is performed for the inhabitants; a dining-hall; and a dormitory, in which each has a separate bed. The latter is a lofty room, furnished with large windows and ventilators, so as to admit and preserve a pure air. For the sick, apartments are allotted, and sick waiters appointed. The number of inhabitants in one room is proportioned to its size, but there are many who have rooms to themselves. No one lives here by compulsion. Each inhabitant pays for rent and board a moderate sum, fixed

Herrnhut. by a committee of overseers, in which the warden of the house presides; whose business it is to maintain good order, attend to the external welfare of the house and its inhabitants, and by his advice and activity to prevent every evil arising from external sources. Besides the warden, an unmarried clergyman resides in the house, appointed to attend to the moral conduct and spiritual concerns of all the single men belonging to the congregation. He hears their complaints, assists them with good advice, and uses all his influence for their benefit, and for the prevention of any evil that would undermine their spiritual happiness.—On the other side of the square is another large building, inhabited by single women; with a chapel, dining hall, dormitory, and a large garden. The internal regulations are exactly the same with those of the house of the single men. There are likewise houses for widowers and widows, who find in them an agreeable retreat, with board and lodging. The poor are cared for and maintained; for which purpose several charitable institutions exist in the congregation.—The manor-house, the house of Count Reuss, the shop and linen warehouse, are the most considerable buildings in Herrnhut; the family houses are built in regular streets opening into the square. Both the streets and houses are kept clean; and besides a watchman at night, an officer is appointed to attend to good order in the day. All strangers are treated with civility; but neither drunken nor disorderly visitors nor beggars are suffered to infest the streets. The latter receive an alms, and are then desired to proceed. The principal trade carried on at Herrnhut is in linen; besides which the work done there by tailors, gloves, shoemakers, cabinet-makers, silversmiths, and other artificers, is well known for its good quality. They have their first prices, and never make any abatement. Every workman receives his wages; no community of goods existing among the brethren, as is falsely supposed; and the contributions towards the support of the establishment at large, the missions, and other charitable institutions, are voluntary. The building and increase of this settlement occasioned no small surprise in the adjacent country; and both in 1732, 1736, and 1737, commissioners were appointed to examine into the doctrines and proceedings of the brethren at Herrnhut. The commissioners made a favourable report; and ever since both Herrnhut and other settlements of the United Brethren in Saxony have been protected, and even several immunities offered them by the court, but not accepted. Herrnhut was visited in 1766 by the late emperor Joseph II. after his return from Dresden, by the present king of Prussia, and by several other royal personages, who expressed their satisfaction in examining its peculiar regulations. The united Brethren have settlements in Saxony, Silesia, and other parts of Germany; in Holland, Denmark, England, Ireland, and America. In England, their principal settlements are at Fulneck near Leeds, and Fairfield near Manchester. In Greenland, North and South America, the West Indies and Russia, they have missions for the propagation of Christianity among the heathen; and in many parts have had considerable success. See *Busching's Account of the Rise and Progress of the Church of the Brethren*, Halle 1781; and *Crantz's History of the Brethren*. London 1780.

HERRNHUT, New, the first mission settlement of the United Brethren, in the island of St Thomas in the West Indies, under the Danish government; begun in 1739; their missionaries having endeavoured to propagate Christianity among the negro slaves ever since 1731, and suffered many hardships and persecutions, from which their converts were not exempted. Many of the planters finding in process of time that the Christian slaves were more tractable, moral, and industrious, than the heathen, not only countenanced but encouraged their endeavours. These were also greatly facilitated by the protection of the king of Denmark. The settlement consists of a spacious negro church, a dwelling-house for the missionaries, negro-butts, out-houses, and gardens. From this place the islands of St Croix and St Jan were at first supplied with missionaries; and the Brethren have now two settlements in each. The negro converts belonging to their church amount in those three islands to near eight thousand souls.

HERRNHUT, New, is also the name of the oldest mission settlement of the United Brethren in Greenland. It is situated on Balls River, a few miles from the sea, near Davis's Straits, on the western coast of Greenland, not far from the Danish colony Godhaab. The two first missionaries were sent from Herrnhut in the year 1733, and their laudable intentions were favoured by the king of Denmark. They had to struggle in this uncultivated, frozen, and savage country, with inconceivable hardships, and found at first great difficulty in acquiring the language of the natives. However, after six years labour and perseverance, they had the satisfaction to baptize four persons, all of one family: and from that time the mission began to prosper, so that in the succeeding years two other settlements were begun, called Lichtensels and Lichtenau: All of them continue in prosperity. About 1300 of the natives have been christianized since the beginning of this mission. See *Crantz's History of Greenland*, London, 1777.

HERSCHEL, the name by which the French, and most other European nations, call the planet discovered by Dr Herschel in the year 1781. The Italians call it Uranos, and the British Georgium Sidus.

HERSE, in *Fortification*, a lattice, or portcullis, in form of a harrow, beset with iron spikes. The word *herse* is French, and literally signifies "harrow; being formed of the Latin *herpes* or *irpes*, which denotes the same. It is usually hung by a rope fastened to a moulinet; to be cut, in case of surprise, or when the first gate is broken with a petard, that the herse may fall, and stop up the passage of the gate or other entrance of a fortress.

The herse is otherwise called a *serrasin*, or *cataract*; and when it consists of straight stakes, without any cross-pieces, it is called *orgues*.

HERSE, is also a harrow, which the besieged, for want of chevaux de frise, lay in the way, or in breaches, with the points up, to incommode the march as well of the horse as of the infantry.

HERSILLON, in the military art, a sort of plank or beam, ten or twelve feet long, whose two sides are driven full of spikes or nails, to incommode the march of the infantry or cavalry. The word is a diminutive of *herse*; the hersillon doing the office of a little herse. See **HERSE**.

HERTFORD.

Herrnhut
Hersillon.

HERTFORD. See **HARTFORD.**—In the account given of this county under the latter name, it was omitted to mention that the East India Company had established a college in it, where persons are to be properly qualified for filling places of trust and importance in the government of India. It is composed of a school, into which boys may be admitted at an early age, and a school for students, 15 years old, in which they are to continue till they have completed their 18th year, or till the directors send them to their particular destinations. In the school, the chief intention is to qualify them for public business, and the first departments of commercial life. The students of the college are to bear public lectures, similar to those which are delivered in the universities. The means of instructing them in the elements of oriental literature will also be attended to, for which purpose they will be taught the rudiments of the Asiatic, Arabic, and Persian languages, and the history, customs, and manners of the eastern nations, as well as the political and commercial relations subsisting between Great Britain and India.

The college is to be under the authority of a principal and seven professors, besides a French master, a drawing-master, a fencing-master, and other suitable instructors.

The principal is required to preach in the college chapel, in rotation with such of the professors as are in holy orders, and to bear his part in performing the other functions of religious worship.

The lectures of the professors are to be arranged under the following heads; viz. oriental literature; mathematics and natural philosophy; classical and general literature; law, history, and political economy.

It is proposed to divide the college year into two terms of 20 weeks each, and the last week of each term is to be dedicated to the examination of the students. A list of their names who are found to have made the greatest proficiency, will be transmitted to the court of directors, who will reward merit in such a manner as may be agreed upon by the college committee. The utmost attention will be paid to their moral and religious instruction, comprehending an account of the evidences, doctrines, and duties of divine revelation.

The college and school were opened on the 3d of Feb. 1806, for the reception of students and pupils. The master of the school is to receive 70 guineas annually, without any additional charge, and students are to pay 50 guineas to the company at the commencement of each term, for which they will receive every accommodation except a few articles of private convenience. Every kind of extravagant expence is to be discouraged.

HERTHA, or **HERTHUS**, in *Mythology*, a deity worshipped by the ancient Germans. This is mentioned by Tacitus, in his book *De Moribus Germanorum*, cap. 40. Vossius conjectures, that this goddess was Cybele: but she was more probably Terra or the Earth; because the Germans still use the word *herth* for the earth, whence also the English *earth*.

HERTZBERG, a considerable town of Germany, in the electorate of Saxony, and on the confines of Lusatia. E. Long. 13. 37. N. Lat. 51. 42.

HERVEY, JAMES, a pious and ingenious divine of the church of England in the 18th century, a writer of

very great popularity among people of the Calvinistic persuasion, was born at Hardington in the year 1714. He was educated at the free grammar-school of Northampton, where he acquired a competent knowledge of the Greek and Latin languages; and in 1731 he was sent to the university of Oxford. The first two or three years of his residence at that seminary were spent, we are told, without much application to study, and therefore without making much improvement; but afterwards becoming acquainted with those who zealously studied what they called *primitive Christianity*, afterwards termed *Methodists*, he became strongly attached both to piety and learning. Independent of his other studies, he learned anatomy from Dr Keil, and natural philosophy from Dr Derham's Physico and Astrotheology; and by the perusal of Mr Spence's essay on Pope's *Odyssey* he improved his style. He attempted the Hebrew language without a teacher, and after relinquishing the study of it in despair, he resumed his labours, and became a tolerable proficient in that forbidding language.

In the year 1740 he was curate of Biddeford in Devonshire, where he had only 60l. a-year, including a stated collection made by his friends. On the death of the rector he was dismissed by the new incumbent, contrary to the earnest expostulation of the parishioners, who offered to maintain him independent of the rector. In 1743 he became curate to his father, who held the living of Weston-Favell in Northamptonshire, and continued in that station till 1750, when his health was rapidly declining, from his intense application to study, and a constitution naturally delicate. Having been artfully decoyed to London for a change of air, he continued about two years in that metropolis, and was soon recalled to Weston-Favell to succeed his father. He got both the livings of Weston and Collingtree in the same neighbourhood, and in 1752 was made M. A. He attended to the duties of both parishes alternately with a curate, in the discharge of which he was fervent and indefatigable. He seldom made use of notes in the pulpit, and constantly catechised the children of his parishioners, nor did he neglect his pastoral visitations at their own houses. So great were his exertions, that he brought on a decline, accompanied with an incessant cough and acute pains, all which he supported, not only with fortitude, but without a single expression of peevishness.

He died without a groan on the 25th of December 1758, about 44 years of age. His piety was ardent and sincere, although in the estimation of good judges he was rather enthusiastic. He was unquestionably a man of the most unblemished moral deportment; his temper was disinterested, and he was truly humble without affectation. To society he was just and punctual, and candid to people of every description. The 700l. which he received for his *Meditations*, were applied to the relief of the indigent and distressed. He was such a rigid Calvinist, that he was almost an Antinomian, whenever he spoke of imputed righteousness. His erudition was respectable, but not such as to place him among scholars of the first rank, although he seems to have been master of the classics. Many have admired the style of his writings, but a judge must certainly pronounce it by far too diffuse to be termed elegant, for it is neither chaste, manly, nor nervous.

Besides.

Hervey
Hesiod.

Besides his *Meditations*, he published remarks on Lord Belingbroke's letters on the use and study of history, so far as they relate to the history of the Old Testament; Theron and Aspasio; Aspasio Vindicated, and Sermons on the Trinity, &c. published from his own MSS. after his death.

HERVEY-Island, one of the South Sea islands discovered by Captain Cook, September 23. 1773, who gave it that name in honour of the earl of Bristol. It is a low island, situated in W. Long. 158. 54. S. Lat. 19. 8.

HESBON, **ESEBON**, or *Hesebon*, in *Ancient Geography*, the royal city of the Amorites, in the tribe of Reuben, according to Moses: Though in Joshua xxi. 39. where it is reckoned among the Levitical cities, it is put in the tribe of Gad; which argues its situation to be on the confines of both.

HESIOD, a very ancient Greek poet; but whether cotemporary with Homer, or a little older or younger than him, is not yet agreed among the learned; nor is there light enough in antiquity to settle the matter exactly. His father, as he tells us in his *Opera et Dies*, was an inhabitant of Cumæ, one of the Eolian isles, now called *Taio Nova*; and removed from thence to Ascra, a little village of Bœotia, at the foot of Mount Helicon, where Hesiod was probably born, and called, as he often is, *Ascræus*, from it. Of what quality his father was, is nowhere said; but that he was driven by his misfortunes from Cumæ to Ascra, Hesiod himself informs us. His father seems to have prospered better at Ascra than he did in his own country; yet Hesiod could arrive at no higher fortune than keeping sheep on the top of Mount Helicon. Here the muses met with him, and entered him into their service:

Erewhile as they the shepherd swain behold,
Feeding beneath the sacred mount his fold,
With love of charming song his breast they fir'd,
There me the heav'nly muses first inspir'd;
There, when the maids of Jove the silence broke,
To Hesiod thus, the shepherd swain, they spoke, &c.

To this account, which is to be found in the beginning of his *Generatio Deorum*, Ovid alludes in these two lines:

*Nec mihi sunt visæ Clío, Clíusque sorores,
Servanti pcedes vallibus Ascra tuis.
Nor Clío nor her sisters have I seen,
As Hesiod saw them in the Ascræan green.*

On the death of the father, an estate was left, which ought to have been equally divided between the two brothers Hesiod and Perses; but Perses defrauded him in the division, by corrupting the judges. Hesiod was so far from resenting this injustice, that he expresses a concern for those mistaken mortals who place their happiness in riches only, even at the expence of their virtue. He lets us know, that he was not only above want, but capable of assisting his brother in time of need; which he often did though he had been so ill used by him. The last circumstance he mentions relating to himself is his conquest in a poetical contention. Archidamus, king of Eubœa, had instituted funeral games in honour of his own memory, which his sons afterwards took care to have performed. Here Hesiod was a competitor for the prize in poetry; and won

a tripod, which he consecrated to the muses. Hesiod having entered himself in the service of the muses, left off the pastoral life, and applied himself to the study of arts and learning. When he was grown old, for it is agreed by all that he lived to a very great age, he removed to Locris, a town about the same distance from Mount Parnassus as Ascra was from Helicon. His death was tragical. The man with whom he lived at Locris, a Milesian born, ravished a maid in the same house; and though Hesiod was entirely ignorant of the fact, yet being maliciously accused by her brothers as an accomplice, he was injuriously slain with the ravisher, and thrown into the sea. The *Theogony*, and *Works and Days*, are the only undoubted pieces of this poet now extant: though it is supposed that these poems have not descended perfect and finished to the present time. A good edition of Hesiod's works was published by Mr Le Clerc at Amsterdam in 1701.

HESPER, **HESPERUS**, in *Astronomy*, the evening star; an appellation given to Venus when she follows or sets after the sun. The word is formed of the Greek *Ἑσπερος*; and is supposed to have been originally the proper name of a man, brother of Atlas, and father of the Hesperides.

Diodorus, lib. iii. relates, that Hesperus having ascended to the top of Mount Atlas, the better to observe and contemplate the stars, never returned more; and that hence he was fabled to have been changed into this star.

HESPERIA, an ancient name of Italy; so called by the Greeks from its western situation. *Hesperia* was also an appellation of Spain; but with the epithet *ultima* (Horace), to distinguish it from Italy, which is called *Hesperia magna* (Virgil), from its extent of empire.

HESPERI CORNU, called the *Great Bay* by the author of Hanno's Periplus; but most interpreters, following Mela, understand a promontory; some Cape Verd, others Palmas Cape: Vossius takes it to be the former, since Hanno did not proceed so far as the latter cape.

HESPERIDÆ, in *Botany* (from the Hesperides); *golden or precious fruit*: the name of the 19th order in Lionæus's Fragments of a Natural Method. See BOTANY.

HESPERIDES, in the ancient mythology, were the daughters of Hesper or Hesperus, the brother of Atlas. According to Diodorus, Hesperus and Atlas were two brothers who possessed great riches in the western parts of Africa. Hesperus had a daughter called Hesperia, who married her uncle Atlas, and from this marriage proceeded seven daughters, called *Hesperides* from the name of their mother, and *Atlantides* from that of their father. According to the poets, the Hesperides were three in number, Ægle, Arothusa, and Hesperethusa. Hesiod, in his *Theogony*, makes them the daughters of Nox, Night, and sets them in the same place with the Gorgons; viz. at the extremities of the west, near Mount Atlas: it is on that account he makes them the daughters of Night, because the sun sets there. The Hesperides are represented by the ancients as having the keeping of certain golden apples, on the other side the ocean. And the poets gave them a dragon to watch the garden where the fruit grows; this dragon they tell us Hercules slew, and carried off

hesperides the apples.—Pliny and Solinus will have the dragon to be no other than an arm of the sea, wherewith the garden was encompassed, and which defended the entrance thereof. And Varro supposes, that the golden apples were nothing but sheep. Others, with more probability, say they were oranges.

The Gardens of the HESPERIDES are placed by some authors at Larache, a city of Fez; by others at Bernich a city of Barca, which tallies better with the fable. Others take the province of Susa in Morocco for the island wherein the garden was seated. And, lastly, Rudbecks places the Fortunate Islands, and the gardens of the Hesperides, in his own country Sweden.

HESPERIDUM INSULÆ, in *Ancient Geography*, islands near the Hesperii Cornu; but the accounts of them are so much involved in fable, that nothing certain can be affirmed of them.

HESPERIS, ROCKET, Dame's Violet, or Queen's Gilliflower; a genus of plants belonging to the tetradynamia class; and in the natural method ranking under the 39th order, *Siliquosæ*. See *BOTANY Index*.

HESPERUS, in fabulous history, son of Cephalus by Aurora, as fair as Venus, was changed into a star, called *Lucifer* in the morning, and *Hesperus* in the evening. See *HESPER*.

HESSE, a country of Germany, in the circle of the Upper Rhine; bounded on the south by Baden and Bavaria; on the east by the principalities of Saxe Meiningen, Saxe Weimar, and the Prussian states; on the north by Brunswick and the Prussian states; and on the west by the same states and Nassau. In the above limits, the county of Katzenelnbogen and some other territories are not included. The whole country, in its utmost length, is near 100 miles, and in some places about 60 in breadth. The air is cold, but wholesome; and the soil fruitful in corn, wine, wood, and pasture. The country abounds also in cattle, fish, and game; salt springs, baths, and mineral waters. The hills, which are many, yield silver, copper, lead, iron, alum, vitriol, pit-coal, sulphur, boles, a porcelain earth, marble, and alabaster. In the Eder, gold is sometimes found; and at Frankenberg a gold mine was formerly wrought. Besides many lesser streams, Hesse is watered by the following rivers, viz. the Lhan, the Fulda, the Eder or Schwalm, the Werra or Weser, and Diemel. The Mayne passes through the county of Katzenelnbogen. This country, like most others in Germany, has its states, consisting of the *prelates*, as they are called, the nobility, and the towns. The diets are divided into general and particular, and the latter into the greater and smaller committees. The house of Hesse is divided into two principal branches, viz. Cassel and Darmstadt, of which Philippsdale, Rhinsfeldts, and Homburg, are collateral branches; and the two first of Hesse-Cassel, and the last of Hesse-Darmstadt. Their rights and privileges are very considerable. In particular, they have votes at the diet of Frankfort. The princes of Hesse-Cassel are not of age till they are 25, but those of Hesse-Darmstadt are so at 18. The right of primogeniture hath been established in both houses. The revenues of Darmstadt are said to amount to 370,000*l.* a-year, and those of Hesse-Cassel to near 380,000*l.* The small county of Schaumberg alone yields a revenue of

10,000*l.* and that of Katzenelnbogen, with the forests of Richardswalde, it is said, was farmed near 200 years ago at 12,000*l.* In 1818 Hesse Darmstadt contained 619,500 inhabitants, and Hesse Cassel 540,000. The troops that the former hires out have often brought him in large sums, especially from Great Britain. He keeps a standing army of 15,000 men. This family is allied to most if not all of the Protestant princes in Europe. The branches of Cassel, Homburg, and Philippsdale, are Calvinists; that of Darmstadt, Lutherans; and that of Rhinsfeldts, Roman Catholics. The prince of Hesse-Cassel, in the year 1749, embraced the Roman Catholic religion; but in 1754 drew up, and confirmed by oath, an instrument, of which all the Protestant princes are guarantees, declaring that the established religion of his dominions should continue in every respect as before, and that his children should be brought up and instructed therein. Here, as in the other Protestant Lutheran countries of Germany, are consistories, superintendants, and inspectors of the church. In the whole landgraviate are three universities, besides Latin schools and gymnasia, for the education of youth. The manufactures of Hesse are linen cloth, hats, stockings, gloves, paper, goldsmiths wares; and at Cassel a beautiful porcelain is made. They have also the finest wool in Germany; but are reproached with want of industry, in exporting instead of manufacturing it themselves.—This is supposed to have been the country of the ancient Catti, mentioned by Tacitus, &c. who in after-ages, were called *Chatti, Chassi, Hassi, and Hessi*. The two chief branches of Cassel and Darmstadt have many rights and privileges in common, which we have not room to specify. Both of them have a seat and vote in the diet of the empire. In 1806, the greater part of Hesse Cassel was incorporated with the kingdom of Westphalia, erected by Bonaparte in favour of his brother Jerome. But in 1813 it was restored to the hereditary prince. Both Hesse Cassel and Hesse Darmstadt have received considerable additions of territory since the year 1800.

HESSIAN FLY, a very mischievous insect which lately made its appearance in North America; and whose depredations threaten in time to destroy the crops of wheat in that country entirely. It is, in its perfect state, a small winged insect; but the mischief it does is while in the form of a caterpillar; and the difficulty of destroying it is increased by its being as yet unknown where it deposits its eggs to be hatched, before the first appearance of the caterpillars. These mischievous insects begin their depredations in autumn, as soon as the wheat begins to shoot up through the ground. They devour the tender leaf and stem with great voracity, and continue to do so till stopped by the frost; but no sooner is this obstacle removed by the warmth of the spring, but the fly appears again, laying its eggs now, as has been supposed, upon the stems of the wheat just beginning to spire. The caterpillars, hatched from these eggs, perforate the stems of the remaining plants at the joints, and lodge themselves in the hollow within the corn, which shows no sign of disease till the ears begin to turn heavy. The stems then break; and being no longer able to perform their office in supporting and supplying the ears with nourishment, the corn perishes about the time that it goes into a milky state. These insects attack also rye, barley, and

Hesse
H
Hessian
Fly.

Hessian
Fly.

and timothy-grass, though they seem to prefer wheat. The destruction occasioned by them is described in the American Museum (a magazine published at Philadelphia) for February 1787, in the following words: "It is well known that all the crops of wheat in all the land over which it has extended, have fallen before it, and that the farmers beyond it dread its approach; the prospect is, that unless means are discovered to prevent its progress, the whole continent will be overrun;—a calamity more to be dreaded than the ravages of war."

This terrible insect appeared first in Long Island during the American war, and was supposed to have been brought from Germany by the Hessians; whence it had the name of the *Hessian fly*. From thence it has proceeded inland at the rate of about 15 or 20 miles annually; and by the year 1789 had reached 200 miles from the place where it was first observed. At that time it continued to proceed with unabating increase; being apparently stopped neither by rivers nor mountains. In the fly state it is likewise exceedingly troublesome; by getting into houses in swarms, falling into victuals and drink; filling the windows, and flying perpetually into the candles. It still continued to infest Long Island as much as ever; and in many places the culture of wheat was entirely abandoned.

The American States are likewise infested with another mischievous insect, named the *Virginian wheat-fly*. This, however, has not yet passed the river Delaware; though there is danger of its being gradually inured to colder climates so as to extend its depredations to the northern colonies also. But it is by no means the same with the Hessian fly. The wheat fly is the same with that whose ravages in the Angoumois in France are recorded by M. Du Hamel; it eats the grain, and is a moth in its perfect state. On the other hand, the Hessian fly has hitherto been unknown to naturalists; it eats only the leaf and stalk; and, in its perfect state, is probably a tenthredo, like the black negro-fly of the turnip.

As of late years great quantities of wheat were imported from America into Britain, it became an object worthy of the attention of government to consider how far it was proper to allow of such importation, lest this destructive insect might be brought along with the grain. The matter, therefore, was fully canvassed before the privy council; and the following is the substance of the information relative to it; and in consequence of this, the importation of American wheat was forbid by proclamation.

1. By a letter, dated 22d April 1788, Mr Bond, consul at Philadelphia, informed the marquis of Caermarthen, that there was a design to export wheat from thence to England; that the fly had made great depredations; and that there might be danger of its thus being conveyed across the Atlantic. He added, that it was not known where the eggs of the insect were deposited, though it was supposed to be in the grain. Steeping the seed in elder juice he recommended as an effectual remedy and preservative of the crop.

2. In consequence of this information his Lordship wrote to Sir Joseph Banks, president of the royal society, desiring him to enquire as much as possible concerning the insect, both with regard to its natural history, and the method of preventing its ravages. In

this research, however, that learned gentleman mistook the insect called the *flying weevil* for the *Hessian fly*. Of this insect he gives a description; but in a little time, being sensible of his mistake, he observed to the council, that his report to the marquis of Caermarthen applied not to the Hessian fly, but to a different insect, viz. the *flying weevil*; that the danger of importing this insect was much greater than that of the Hessian fly. The corn already brought from America, he was of opinion, might easily be examined, and a discovery made whether the fly had been there. Among other methods which might be used for this purpose, that of putting the corn among water was one, when the infected grains would rise to the top, and might then be opened and examined. Some slight trials of that kind he had already made; and found manifest signs of the fly in some grains which he had opened.

3. A farther account of the insect was given by Dr Mitchel, in consequence of the above-mentioned letter from the marquis of Caermarthen. According to him it was first discovered in the year 1776, on Staten Island, and the west end of Long Island; since that time it proceeded regularly through the southern district of the state of New York, part of Connecticut; and at the time of giving the account, July 1788, had got into New Jersey. As it appeared about the time that the Hessian troops arrived, an opinion had gone abroad that they brought it along with them; but the Doctor was of opinion that it is a native animal, nourished by some indigenous plant, but which then, for the first time, came among the wheat, and found it proper food. He had seen the caterpillar, chrysalis, and fly, but never could find the egg, or discover where it is deposited. The caterpillar appears, as has already been said, in autumn, and, after having devoured the tender stalk, soon becomes a chrysalis, coloured like a flax-seed; which, being fixed between the leaf and the stalk, injures the plant by its mechanical pressure; from this proceeds the fly, which is either able of itself to sustain the intense winter frosts, or lays eggs capable of doing it. Early in the spring the caterpillar appears again, even when the heat is scarce sufficient to make the wheat grow; its ravages, therefore, are at this period particularly destructive; and it passes through its metamorphoses with such speed, as to produce a third generation while the wheat is yet tender and juicy; however, as the corn has by this time grown considerably, the third generation is not so destructive as the second. It hurts chiefly by rendering the straw weak, and liable to break down when loaded afterwards by the weight of a full ear; "and sometimes (says the Doctor) it will be infested by the fourth swarm before harvest."

4. In another communication of Sir Joseph Banks, dated July 24. 1788, he makes some general observations on the nature of those caterpillars from which flying insects proceed; and to which class both the flying weevil and Hessian fly belong. Nature, he observes, has provided against the kinds of danger these tender insects are most likely to meet with. Thus, in climates where the winters are severe, the eggs of the most tender insects resist the force of the usual frost; in seasons of remarkable severity, indeed, some are destroyed;

Hessian
Fly.

stroyed; but a sufficient number always escape for propagating the species. The young caterpillar, if hatched before its proper food be ready, will survive even weeks before it perishes for want of nourishment; and in some few instances where it is hatched in the autumn, it is directed by instinct to spin a web, in which it remains torpid and without food during the whole winter. The chrysalis, though deprived of locomotion, is capable of resisting various dangers, arising from cold, heat, wet, &c.; and the length of time which the animal remains in that state is capable of very considerable extension. The complete animal, tender as it appears, and intended to exist no longer than is necessary to fulfil the business of propagation, which, in some species, is gone through in a few days, nevertheless is capable, in some instances, of enduring the utmost variation of climate; and if by accidental circumstances, the sexes are prevented from meeting, its short life is extended to many times the amount of its usual duration.

The observations on the fly made by Sir Joseph in this paper, are not different from those already related; only he dissents from the opinion of Mr Bond, that the eggs are laid on the grain; thinking it more probable from analogy, that they are deposited on the straw; and being shaken off from thence by the strokes of the flail in thrashing, are mixed with the corn; from whence it must be very difficult to separate them. Hence he concluded, that there was an apparent and very great risk of importing the eggs along with the corn; and there was no doubt, that when once they had got a footing, they would establish themselves in Britain as well as in America. It must be observed, however, that none of the grain which was examined showed any signs of this fly, its eggs, or caterpillars; such insects as were found in some diseased specimens being only the weevils common in England as well as in other countries; though some which were inspected in the month of August this year contained the chrysalis of some insects, which Sir Joseph Banks was of opinion might be the flying weevil; and as he did not know whether these would revive or not, he gave it as his opinion, that the cargo in which they were found ought not to be suffered to come into the kingdom.

5. In order to procure all the intelligence that could be had concerning these insects, the duke of Dorset addressed a letter to the Royal Society of Agriculture in France, to know whether any of them exists in that country. The report of the society was accompanied with a drawing of two insects; one of which was supposed to be the caterpillar of the Hessian fly, from its attacking the wheat only when in the herb; beginning its ravages in autumn, reappearing in the spring, and undergoing the metamorphoses already mentioned. "That insect (say the society), whose havock has been well known in America only since 1776, does not appear to differ from it, as well as we can judge from a very short description of those which have been observed in the north, and of which the history is contained in the different volumes of the academy of sciences of Stockholm. We know that there exist in France caterpillars whose manner of living resembles that of those insects; but the mischief which they do to corn having never been considerable enough to attract the attention of government, and not having been ourselves

engaged in following in detail the history of that species of caterpillar, we regret not being able to say any thing particular upon that subject." The rest of the report contains an account of the flying weevil.

6. Further recourse was now had to America for information. The marquis of Caermarthen wrote to Sir John Temple at New York, the British consul general; and this gentleman applied to Colonel Morgan, who had been more curious with respect to this insect than any other person with whom he was acquainted. His account was, that the Hessian fly was first introduced into America by means of some straw made use of in package, or otherwise landed on Long Island at an early period of the late war; and its first appearance was in the neighbourhood of Sir William Howe's debarkation, and at Flat Bush. From thence it spread in every direction, but at first very slowly; and it was not till the year 1786 that they reached Mr Morgan's farm, situated not quite 50 miles from New York. No damage was done the first season, and very little the second; but in 1788 they were materially damaged, and in some places totally destroyed all round. "The name of *Hessian fly* (says Mr Morgan) was given to this insect by myself and a friend early after its appearance on Long Island." In a letter to General Washington, dated July 31st 1788, Mr Morgan treats particularly of the insect itself, and mentions several experiments made by himself to oppose its depredations. The result of these was, that good culture of strong soil, or well manured lands, may sometimes produce a crop of wheat or barley, when that sowed on poor or middling soil, without the other advantages, will be totally destroyed. "But (says he) as the insect lives in its aurelia state in straw and litter through the winter, I find that unmixed barnyard manure spread on the land in the spring multiplies the fly to an astonishing degree: hence the farmer will see the necessity of mixing his yard with earth and marl in heaps; adding, where he can do it, a quantity of lime, and changing the heaps, after they have undergone the necessary fermentation, that their parts may be well incorporated, and a new digestion brought on, which will effectually destroy the insects. Rolling of wheat just before the first frosts in autumn, and soon after the last in spring, or before the wheat begins to pipe or spindle, has also a good effect. In the first place, it is a part of good culture; and, secondly, the roller crushes and destroys a great proportion of the insects. Top-dressings of lime, or of live ashes, are useful as manures, and may (when applied about the times I have mentioned as proper for rolling) be offensive to the insect; but if used in sufficient quantity to destroy them, would, I believe, destroy the wheat also. In the year 1782, a particular species of wheat was introduced on Long Island, which is found to resist the fly, and to yield a crop when all other wheats in the same neighbourhood are destroyed by it. But as this wheat has been incautiously sowed in field with other kinds, it has generally become so mixed by the farmers, as to suffer in its character in proportion to this mixture; insomuch, that some farmers, from inattention to this circumstance, have condemned it altogether. Fortunately, however, some crops have been preserved from this degeneration; and I was so lucky as to procure the whole of my last year's seed of the purest kind:

Hessian
Fly.

the consequence of which has been a good crop, whilst my neighbours fields, sowed with other kinds of wheat, have been either totally destroyed or materially injured. I have satisfied myself that this species of wheat was brought to New York in 1782; that a cargo of it was then sent to Messrs Underhill's mill to be manufactured into flour; and that from seed saved out of this parcel, the yellow-bearded wheat was propagated. It is a generally received opinion, that the capacity of the yellow-bearded wheat to resist the attacks of the fly is owing to the hardness or solidity of the straw; but when we reflect that other wheats are sometimes wholly cut off in the fall of the year, and sometimes early in the spring, before the season of its running to straw, we shall be induced to assign some other cause. I cannot point out more than two distinctions of this from other wheats. The first is in the ear, at or after harvest. The obvious difference, then, is in the colour of the chaff. The second can only be observed by the miller, who says, "this grain requires to be more aired and dried than any other wheat before grinding, or it will not yield its flour so kindly, as it is of a more oily nature; but when thus aired and dried, the quality and quantity of its flour are equal to that of the best white wheat."

7. In a letter to Mr Wadsworth, dated 22d August 1788, we are informed that the experiments made with elder juice, recommended as a preventive of this evil by Mr Bond, were fallacious, and had failed in every instance in 1785; but the efficacy of the yellow-bearded wheat in resisting the attacks of the fly is confirmed. The progress of the fly northward is likewise confirmed; but we are told that it has disappeared in many places near New York, where it formerly abounded.

8. In consequence of the correspondence between the marquis of Caermarthen and Mr Bond, the latter made very particular inquiry concerning this mischievous insect, and has given a better account of it than any of the above. "The Hessian fly (says he) is a small dark fly, with thin, long, black legs; clear transparent wings, extending far beyond the body of the trunk; with small, though perceptible, horns or feelers projecting from the snout. These I have seen appear in size and shape like a little fly which attacks cheese in this country, and which is very closely watched by the keepers of dairies here, as productive of the worm or skippers which destroy cheese; and it is remarkable, that the worm produced from the egg of the Hessian fly, though rather thinner and longer, bears a strong resemblance to the worm in cheese. The horns which evidently appear on the Hessian fly may be provided by nature as feelers to enable them to perforate hard grain, as well as grain in a softer state; though I have not yet seen any person who has perceived the egg, worm, or fly, in the grain of the wheat, or who has found any nit, mucus, or even dust, in the dry straw, in ricks or barns, to induce a belief that the egg is there deposited after the harvest. One publication, signed a Landholder, goes so far as to favour the idea that the fly even perforates the seed, and deposits its eggs therein. His ideas have been condemned, as tending to mislead others; but by no means confuted either by reason or experiment. An observation I made myself, gave me some cause to apprehend that the

idea mentioned in the paper signed a Landholder was founded in fact: Upon examining a barn, in a country wherein the fly had not been known to injure the harvest (though it has now certainly made its appearance there within a few weeks), I observed in the flaws and apertures where the wood was decayed, over which cobwebs were woven, several of these flies entangled in the webs, many of them dead, but some alive, and struggling to disengage themselves; from hence I concluded that there was a propensity in the fly to get into the mow; but whether with a purpose of mere shelter and nurture, or with a view to deposit its eggs, I am at a loss to decide."

9. Mr Bond then refers to some observations by a Mr Potts and Mr Cleaver, which, with several other papers on the subject, he had inclosed in his letter to the marquis. The former was a farmer in the county of Chester, who stacked his wheat in autumn 1788, at a time when the fly had not been seen in or near that county. About six or seven weeks after the harvest he had occasion to thresh some of his wheat; and with a view to prevent its scattering and wasting, he threw the sheaves from the rick upon a large sheet. On taking up the sheaves to carry them to the threshing-floor, he perceived a great number of flies, answering precisely the description of the Hessian fly, lying upon the sheet, some dead, and others in a torpid state; from whence he concluded that the fly had got a footing in his rick; but from any examination either of the straw or grain, no trace of the eggs being deposited was discovered. Mr Cleaver, a farmer in the same county, apprehending that the fly might approach his neighbourhood, sowed some wheat in his garden, which grew so as to appear above ground in less than a fortnight, when a violent north-east wind came on; and immediately after he perceived small clouds of flies over and about the wheat he had sown. He examined the grain in a few days; and found that numbers of the flies had deposited their eggs in the heart of the main stalk, and many of them lay dead on the ground where the wheat was sown, and near it. Many of the eggs were found in the stalk; and some small white worms produced from other eggs were lately discovered in the stalk very near the root of the wheat. Wherever these worms were found, the whole of the individual stalk was perceptibly changed in point of colour, tending to a yellowish cast; the top hanging down quite shrunk and withered. In some of the wheat which was carefully examined, the eggs were found within the stalk, of a very minute size and whitish colour, with something of a yellow tinge. In those where the worm was formed, it was carefully wrapped up, surrounded by different coats of the shoot in which it lay, as if it had been skilfully and tenderly rolled up for its preservation; around it the stalk was plainly eaten away, some nearly through. The worm strongly resembles the skipper in cheese, somewhat thinner, and rather longer, of a whitish cast. The ground on which this wheat was sown was rich garden ground, high and dry; the natural soil a strong red clay; few of the shoots, of which there were many in one cluster, in proportion to their number, were hurt by the fly. This was imputed to the strength of the soil, which producing a robust powerful growth, resisted, in a

Hessian
Fly.

great

Hessian Fly. grant degree, the attack of the fly, though the weak shoots suffered generally.

10. A similar account of the Hessian fly is given by Mr Jacobs, an experienced farmer in the county of Montgomery. From his observations the egg is usually deposited in the funnel or sheath, a little above the first joint. When the eggs are laid in the autumn or spring, they are utterly destructive of the growth of the wheat; but when they are deposited shortly before the harvest, the grain or even the stalk is scarcely affected, especially in rich ground. The egg, he says, is at first very minute; it grows rapidly, becomes full and large, and turns to a brown hue, in size and colour very like a flax seed. A material difference was also perceived between rich and poor ground with respect to the ravages of the fly; but none between moist and dry soils. He is also of opinion that the yellow-bearded wheat will resist the attacks of the fly; and that rolling and feeding the wheat will be of great service.

11. A farmer in Jersey, who dates his letter from Hunterdon, Jan. 30. 1787, observes, that though the fly is supposed to advance about 15 miles annually, and neither waters nor mountains obstruct its passage, yet when disturbed, he never saw them take a flight of above five or six feet; nevertheless they are so active, that it is very difficult to catch them. They first appear towards the end of September; and soon after their eggs appear hatched, in colour and size like a flax seed; they are very low at the joints; some even in the ground; and here they harbour all winter. On their first appearance in any district, their numbers being small they seldom eat off the crop in this state, which is often the case the second or third year. In the spring, after warm weather, they again appear as a small worm, and destroy the crop. The remedies proposed by this farmer are, sowing upon rich ground, elder, and rolling. A gentleman whose account was dated on the first of November 1786, says, that their eggs resemble what is commonly called the *fly-blow* on meat, being very small, and only one in a place. Soon after, the other blades of wheat proceeding from the same kernel incline the first, the egg is covered, and agreeable to the usual progress of insects arrives at the state of a worm, and descends towards the root, where it consumes the tender blade, sometimes destroying the whole crop in the fall; but if, by reason of the fertility of the soil, and other concurrent circumstances, the vegetation is so rapid as to baffle their efforts, some of the latter-laid eggs, when at the worm state, entrench themselves in the ground to the depth of an inch or more, where he had found them after severe frosts changed from a white to a greenish colour, and almost transparent; from this they proceed to the auralia state, and thus continue probably in the ground till the spring, when the fly is again produced, which again lays its eggs, and finishes the work begun in the fall, to the total destruction of the crop. Another piece of intelligence he gives, but not from his own observation, that by seeding the wheat very close in the winter and spring, if the land is rich, it will again spring up, and the worms do not much injure the second growth. By another correspondent we are informed, that maritime places are less liable to be infested with the fly than the interior parts of the country; and

therefore recommends as an experiment, that fine salt should be sprinkled on the wheat just before, or very soon after, the appearance of the fly. By others, elder has been much recommended, as well as rolling, &c. though the bearded wheat already mentioned seems to be the only effectual remedy.

12. By another communication from Mr Morgan to the Philadelphia Society for promoting Agriculture, he informs us, that he had made himself acquainted with the fly by breeding a number of them from the chrysalis into the perfect state. The fly is at first of a white body with long black legs and whiskers, so small and motionless as not to be easily perceived by the naked eye, though very discernible with a microscope; but they soon become black and very nimble, both on the wing and feet, being about the size of a small ant. During the height of the brood in June, where 50 or 100 of the nits have been deposited on one stalk of wheat, he has sometimes discovered, even with the naked eye, some of them to twist and move on being disturbed: this is while they are white; but they do not then travel from one stalk to another, nor to different parts of the same stalk. The usual time of their spring-hatching from the chrysalis is in May. "Those (says he) who are doubtful whether the fly is in their neighbourhood, or cannot find their eggs or nits in the wheat, may satisfy themselves by opening their windows at night and burning a candle in the room. The fly will enter in proportion to their numbers abroad. The first night after the commencement of wheat harvest, this season, they filled my dining-room in such numbers as to be exceedingly troublesome in the eating and drinking vessels. Without exaggeration I may say, that a glass tumbler from which beer had been just drunk at dinner, had 500 flies in it in a few minutes. The windows are filled with them when they desire to make their escape. They are very distinguishable from every other fly by their horns or whiskers." With regard to the cure, it seems to be confirmed that the sowing of that called the *yellow-bearded wheat* can only be depended upon. The fly indeed will reside in fields of this wheat, and lay its eggs upon the stalks; but no injury was ever known to happen, except in one single instance, where it was sown in a field along with the common sort, and that in a very small proportion to it. By another account, however, we are told that the yellow-bearded wheat is equally liable to be destroyed in the autumn with the common kind; so that the only method of securing the crop is by sowing it late in the season, when the fly is mostly over.

13. The utmost pains were taken by the British government to find out whether this destructive insect exists in Germany or any of the northern countries of Europe; but from the accounts received, it appears that it has not hitherto been observed, or at least if it exists, the damage done by it is too inconsiderable to attract notice.

14. From the whole correspondence on this subject, which from the abridgement just now given of it is evidently somewhat discordant, Sir Joseph Banks drew up a report for the privy council, dated March 2. 1789, in which he states the following particulars: 1. The appearance of the fly in Long Island was first observed in 1779. We must suppose this to be meant that

Hessian Fly.

Hessian
Fly.

that its destructive effects became then first perceptible; for it seems undoubtedly to have been known in the year 1776. 2. The opinion of Colonel Morgan, that it was imported by the Hessians, seems to be erroneous, as no such insect can be found to exist in Germany or any other part of Europe. 3. Since its first appearance in Long Island it has advanced at the rate of 15 or 20 miles a-year, and neither waters nor mountains have impeded its progress. It was seen crossing the Delaware like a cloud, from the Fall's Township to Makefield; had reached Saratoga 200 miles from its first appearance, infesting the counties of Middlesex, Somerset, Huntington, Morris, Sussex, the neighbourhood of Philadelphia, all the wheat countries of Connecticut, &c. committing the most dreadful ravages; attacking wheat, rye, barley, and timothy-grass. 4. The Americans who have suffered by this insect, speak of it in terms of the greatest horror. In Colonel Morgan's letter to Sir John Temple, he uses the following expressions. "Were it to reach Great Britain, it would be the greatest scourge that island ever experienced; as it multiplies from heat and moisture, and the most intense frosts have no effect on the egg or aurelia. Were a single straw, containing the insect, egg, or aurelia, to be carried and safely deposited in the centre of Norfolk in England, it would multiply in a few years, so as to destroy all the wheat and barley crops of the whole kingdom. There cannot exist such an atrocious villain as to commit such an act intentionally. 5. No satisfactory account of the mode in which this insect is propagated has hitherto been obtained. Those which say that the eggs are deposited on the stalk from six or eight to 50, and by their growth compress and hinder the stalk from growing, are evidently erroneous, and the authors of them have plainly mistaken the animal itself for its eggs. It is sufficient to remember, that eggs do not grow or increase in bulk, to prove that what they observed was not eggs. 6. The landholder's opinion, that the eggs are deposited on the ripe grains of wheat, though contradicted by Colonel Morgan, is not disproved, as the colonel advances no argument against it. 7. A letter dated New York, September 1. 1786, says, that the eggs are deposited on the young blade, resembling what we call a *fly-blow* in meat; very small, and but one in a place: but this, though the only natural mode of accounting for the appearance of the insect, had it been true, must undoubtedly have been confirmed by numbers of observations. 8. Even though this should be found hereafter to be the case, there will still remain a danger of the aurelias being beaten off by the flail from the straw in threshing the wheat, and imported into Britain along with it; the presence of these flies in barns having been fully proved by the observations of Messrs Potts and Bond. 9. None of the remedies proposed against this destructive insect have been in any degree effectual, excepting that of sowing the yellow-bearded wheat; the straw of which is sufficiently strong to resist the impression of the insect, and even if its eggs are deposited upon it, receives little injury in point of produce in grain: this provides, however, no remedy for the loss of the barley crop, nor for that which must be incurred by sowing the yellow-bearded wheat on lands better suited by nature for the produce of other kinds: it appears also that

this very kind is liable to degenerate, and probably from a different cause than that proposed by Colonel Morgan, viz. the mixture with common wheat. 9. Though the Agricultural Society at Philadelphia, as well as Colonel Morgan, have declared their opinions decisively, that no danger can arise from wheat imported into Britain, as the insect has no immediate connection with the grain; yet with nearly, if not exactly the same materials before him which these gentlemen were furnished with, Sir Joseph Banks could not avoid drawing a conclusion directly contrary; and he concludes his report with the words of Mr Bond in a letter to the marquis of Caermarthen. "Satisfactory as it would be to my feelings to be able to say with precision, that I apprehend no danger of extending the mischief by seed, my duty urges me to declare, that I have not heard nor seen any conclusive fact by which I could decide on a matter of such importance; and till that test occurs, the wisdom of guarding against so grievous a calamity is obvious."

On the 27th of April the same year, another paper, by way of appendix to the foregoing, was given in by Sir Joseph Banks. In this he again observes, that none of the descriptions of any European insect hitherto published answer exactly to the Hessian fly. In a letter from Mr Bond to the marquis of Caermarthen, he mentions another kind of insect in the state of Maryland, called by way of eminence *the fly*; and which in some things resembles the Hessian fly, though it cannot be accounted the same. It makes its way into the mow, and bites the end of the grain perceptibly, and no doubt deposits its eggs in the grain itself; since it has been observed, that wheat recently threshed, and laid in a warm dry place, will soon be covered with an extreme clammy crust, which binds the wheat on the surface together in such a way as to admit its being lifted in lumps; but the wheat beneath will not be hurt to any considerable depth. Such is the quality of this fly, that if the hand be inserted into the heap affected by it, watery blisters are immediately raised; and the farmers and slaves, riding upon bags of this infected wheat, never fail to be severely blistered thereby. "This insect (says he) is called in Maryland the *Revolution fly*, by the friends of the British government; but from all I can learn it is not the same insect which originated on Long Island, and is called the *Hessian fly* (by way of opprobrium) by those who favoured the revolution. All the papers I have read on the Hessian fly are very inaccurate, not to say contradictory; and I am convinced it is by no means a settled point at this moment, in what manner and place the eggs of these insects are deposited. The policy which induced government to open the ports being founded on an appearance of a scarcity of corn, that evil may be remedied by the admission of flour instead of grain; and though the countries from whence the flour is carried will have the advantage of the manufacture, still that cannot be reckoned as an object, when opposed in the scale to an evil of such immense magnitude as the introduction of so destructive an insect may occasion. The ravages here are beyond conception ruinous. Many farmers have had their crops so completely cut off as to be left without bread-corn or even seed-corn. If the measure of confining the importation to flour alone should be adopted, great attention

Hessian
Fly.

attention should be paid to the quality of the flour admitted into the British ports. An infinite deal of the wheat of the last harvest is of a very wretched quality; and stratagems will be practised to give an extensive vent to so essential a staple of the middle states of America."

In another letter to the same nobleman, Mr Bond expresses himself to the following purpose. "I have not been able to collect any decided information which fixes the essential point, how far the insect may be communicated by seed. It is a matter at this time quite undecided here; nor have I heard or observed any very conclusive reason to suppose that the fly makes its way generally into barns and ricks. A very intelligent farmer in the county of Bucks, informed me that it was the prevailing opinion there, and so I found it, that the fly did not, either in the field or in the mow, affect the grain of the wheat: a neighbour of his, in threshing the little wheat he had saved last harvest, observed the fly rise from the straw in great numbers wherever it was struck by the flail; but though it was at first presumed that the fly had insinuated itself into the mow for the purpose of depositing its eggs in the grain or in the straw, no trace of the egg could be discovered from the appearance of any mucus or dust, either in the grain or in the straw; hence it was inferred that all the mischief was done in the field."

HESYCHIUS, the most celebrated of all the ancient Greek grammarians whose works are now extant, was a Christian; and, according to some, the same with Hesychius patriarch of Jerusalem, who died in 609. He wrote a Greek lexicon; which, in the opinion of Casaubon, is the most learned and useful work of that kind produced by the ancients. Schrevelius published a good edition of it in 1668, in 4to, with notes; but the best is that of John Alberti, printed at Leyden in 1746, in two vols folio.

HETERIARCH, HÆTERIARCHA, in antiquity, an officer in the Greek empire, whereof there were two species; the one called simply *heteriarch*, and the other *great heteriarch*, who had the direction of the former.

The word is Greek, *τρασιμαχος*, formed of the Greek *τρασος*, *socius*, "companion, ally," and *αρχη*, *imperium*, "command." Their principal function was to command the troops of the allies; besides which, they had some other duties in the emperor's court, described by Codin, *De Officiis*, cap. 5. N° 30, 31, 32, 37.

HETEROCLITE, HÆTEROCLITON, in *Grammar*, an irregular or anomalous word, which either in declension, conjugation, or regimen, deviates from the ordinary rules of grammar. The word is Greek, *ετεροκλητος*; formed of *ετερος*, *alter*, "another, different," and *κλιση*, "I decline."

Heteroclite is more peculiarly applied to nouns which vary or are irregular in point of declension; having fewer cases, numbers, &c. than ordinary; or that are of one declension in one number, and another in another: as *Hoc vas, vasis; hæc vasa, vasorum*.

HETERODOX, in *Polemical Theology*, something that is contrary to the faith or doctrine established in the true church. The word is formed of the Greek *ετεροδοξος*; a compound of *ετερος*, "alter," and *δοξα*, "opi-

nion." Thus, we say a *heterodox* opinion, a *heterodox* doctrine, &c. The word stands in opposition to *orthodox*.

HETEROGENEITY, in *Physics*, the quality or disposition which denominates a thing *heterogeneous*. The word is also used for the heterogeneous parts themselves: in which sense, the heterogeneities of a body are the same thing with the impurities thereof.

HETEROGENEOUS, or HÆTEROGENEAL, literally imports something of a different nature, or that consists of parts of different or dissimilar kinds; in opposition to *homogeneous*. The word is Greek; formed of *ετερος*, *alter*, "different," and *γενος*, *genus*, "kind;" *q. d.* composed of different kinds of parts.

HETEROGENEOUS Light, is by Sir Isaac Newton said to be that which consists of rays of different degrees of refrangibility. Thus the common light of the sun or clouds is heterogeneous, being a mixture of all sorts of rays.

HETEROGENEOUS Nouns, one of the three variations in irregular nouns; or such as are of one gender in the singular number, and of another in the plural.—Heterogeneous, under which are comprehended mixed nouns, are sixfold. 1. Those which are of the masculine gender in the singular number, and neuter in the plural; as, *hic tartarus, hæc tartara*. 2. Those which are masculine in the singular number, but masculine and neuter in the plural; as, *hic locus, hi loci et hæc loca*. 3. Such as are feminine in the singular number, but neuter in the plural; as, *hæc carbasus, et hæc carbasæ*. 4. Such nouns as are neuter in the singular number, but masculine in the plural; as *hoc cælum, hi cæli*. 5. Such as are neuter in the singular, but neuter and masculine in the plural; as, *hoc rastrum, hi rastræ, et hæc rastra*. And, 6. Such as are neuter in the singular, but feminine in the plural number; as *hoc epulum, hæc epulæ*.

HETEROGENEOUS Quantities, are those which are of such different kind and consideration, as that one of them, taken any number of times, never equals or exceeds the other.

HETEROGENEOUS Surds, are such as have different radical signs; as \sqrt{aa} , and $\sqrt[3]{bb}$; $\sqrt[5]{9}$, and $\sqrt[7]{19}$.

HETEROSCII, in *Geography*, a term of relation, denoting such inhabitants of the earth as have their shadows falling but one way, as those who live between the tropics and polar circles; whose shadows at noon in north latitude are always to the northward, and in south latitude to the southward.

HETH, the father of the Hittites, was the eldest son of Canaan (Gen. x. 15.), and dwelt southward of the promised land, at Hebron or thereabouts. Ephron, an inhabitant of Hebron, was of the race of Heth, and this whole city in Abraham's time was peopled by the children of Heth. There are some who maintain that there was a city called Heth, but we find no footsteps of it in the Scripture.

HETRURIA, or ETRURIA, a celebrated country of Italy, to the west of the Tyber. It originally contained 12 different nations, which had each their respective monarch. Their names were Veientes, Clusini, Perusini, Cortonenses, Arretini, Vetuloni, Volaterrani, Rusellani, Volscinii, Tarquinii, Falisci, and Cæretani. The inhabitants were particularly famous for their superstition and strict confidence in omens, dreams,

auguries.

Meturria
Hewson.

auguries, &c. They all proved powerful and resolute enemies to the rising empire of the Romans, and were conquered only after much effusion of blood.

HEVÆI, in *Ancient Geography*, one of the seven tribes who occupied Canaan; a principal and numerous people, and the same with the *Kadmonæi*, dwelling at the foot of Hermon and part of Libanus, or between Libanus and Hermon (Judges iii. 3.). To that Bochart refers the fables concerning Cadmus and his wife Harmonia, or Hermonia, changed to serpents; the *Hevæ* denoting a wild beast, such as is a serpent. Cadmus, who is said to have carried the use of letters to Greece, seems to have been a Kadmonæan; of whom the Greeks say that he came to their country from Phœnicia.

HEUCHERA, a genus of plants belonging to the pentandria class. See *BOTANY Index*.

HEVELIUS, or **HEVELKE**, *John*, an eminent astronomer, was born at Dantzic in 1611. He studied in Germany, England, and France, and every where obtained the esteem of the learned. He was the first that discovered a kind of libration of the moon, and made several important observations on the other planets. He also discovered several fixed stars which he named the *firmament of Sobieski*, in honour of John III. king of Poland. His wife was also well skilled in astronomy, and made a part of the observations published by her husband. In 1673 he published a description of the instruments with which he made his observations, under the title of *Machina Cœlestis*; and in 1679 he published the second part of this work; but in September the same year, while he was at a seat in the country, he had the misfortune to have his house at Dantzic burnt down. By this calamity he is said to have sustained a loss of several thousand pounds; having not only his observatory and all his valuable instruments and apparatus destroyed, but also a great number of copies of his *Machina Cœlestis*; which accident has made this second part very scarce, and consequently very dear. In the year 1690 were published *Firmamentum Sobiescianum* and *Prodromus astronomica et novæ tabulæ solares, una cum catalogo fixarum*, in which he lays down the necessary preliminaries for taking an exact catalogue of the stars. But both these works are posthumous: for Hevelius died in 1687, on his birth-day, aged 76. He was a man greatly esteemed by his countrymen, not only on account of his great reputation and skill in astronomy, but as a very excellent and worthy magistrate. He was made a burgo-master of Dantzic: which office he is said to have executed with the utmost integrity and applause. He was also very highly esteemed by foreigners; and not only by those skilled in astronomy and the sciences, but by foreign princes and potentates: as appears abundantly from a collection of their letters which was printed at Dantzic in the year 1683.

HEUSDEN, a strong town of the United Provinces, in Holland, seated on the river Maese, among marshes, with a handsome castle, in E. Long. 5. 3. N. Lat. 51. 47.

HEWSON, *WILLIAM*, a very ingenious anatomist, was born in 1739. He became assistant to Dr Hunter, and was afterwards in partnership with him; but on their disagreement, read anatomical lectures at his own house (in which he was seconded by Mr Falconer).

Hewson
Hexapla.

He wrote *Inquiries into the Properties of the Blood*, and the *Lymphatic System*, 2 vols; and disputed with Dr Monro the discovery of the lymphatic system of vessels in oviparous animals. He died in 1774.

HEXACHORD, in ancient music, a concord called by the moderns a *sixth*.

HEXAGON, in *Geometry*, a figure of six sides and angles; and if these sides and angles are equal, it is called a *regular hexagon*.

HEXAHEDRON, in *Geometry*, one of the five platonic bodies, or regular solids, being the same with a cube.

HEXAMETER, in ancient poetry, a kind of verse consisting of six feet; the first four of which may be indifferently either spondees or dactyles; the fifth is generally a dactyl, and the sixth always a spondee. Such is the following verse of Horace:

1 2 3 4 5 6
Aut pro|desse vo|lunt, aut| dele|ctare po|ietæ.

HEXAMILION, **HEXAMILI**, or *Hexamilium*, a celebrated wall, built by the emperor Emanuel in 1413 over the isthmus of Corinth. It took its name from *ἕξ*, *six*, and *μῖλον*, which in the vulgar Greek signifies a *mile*, as being six miles long.

The design of the hexamilion was to defend Peloponnesus from the incursions of the barbarians. Amurath II. having raised the siege of Constantinople in the year 1424, demolished the hexamilium, though he had before concluded a peace with the Greek emperor. The Venetians restored it in the year 1463, by 30,000 workmen, employed for 15 days, and covered by an army commanded by Bertoldo d'Este general of the land forces, and Louis Loredano, commander of the sea.—The Infidels made several attempts upon it; but were repulsed, and obliged to retire from the neighbourhood thereof: but Bertoldo being killed at the siege of Corinth, which was attempted soon after, Bertino Calcinato, who took on him the command of the army, abandoned, upon the approach of the beglerbeg, both the siege and the defence of the wall which had cost them so dear; upon which it was finally demolished.

HEXANDRIA, in *Botany*, (from *ἕξ*, *six*, and *ἄνθη*, *a man*); the name of the sixth class in Linnæus's sexual method, consisting of plants with hermaphrodite flowers, which are furnished with six stamina or male organs, that are of an equal length. See *BOTANY Index*.

HEXAPLA (formed of *ἕξ*, *six*, and *ἄπλοῦ*, *I open, I unfold*), in church-history, a Bible disposed in six columns; containing the text, and divers versions thereof, compiled and published by Origen, with a view of securing the sacred text from future corruptions, and to correct those that had been already introduced.

Eusebius, *Hist. Eccl. lib. vi. cap. 16.* relates, that Origen, after his return from Rome under Caracalla, applied himself to learn Hebrew, and began to collect the several versions that had been made of the sacred writings, and of these to compose his *Tetrapla* and *Hexapla*; and others, however, will not allow him to have begun till the time of Alexander, after he had retired into Palestine, about the year 231.

To conceive what this *Hexapla* was, it must be observed, that, besides the translation of the sacred writings, called the *Septuagint*, made under Ptolemy Philadelphus,

exempl. Iadelpbus, above 280 years before Christ, the Scripture had been since translated into Greek by other interpreters. The first of those versions, or (reckoning the Septuagint) the second, was that of Aquila, a proselyte Jew, the first edition of which he published in the 12th year of the emperor Adrian, or about the year of Christ 128; the third was that of Symmachus, published, as is commonly supposed, under Marcus Aurelius, but, as some say, under Septimius Severus, about the year 200; the fourth was that of Theodotion, prior to that of Symmachus, under Commodus, or about the year 175. These Greek versions, says Dr Kennicott, were made by the Jews from their corrupted copies of the Hebrew, and were designed to stand in the place of the Seventy, against which they were prejudiced, because it seemed to favour the Christians. The fifth was found at Jericho, in the reign of Caracalla, about the year 217; and the sixth was discovered at Nicopolis, in the reign of Alexander Severus, about the year 228: lastly, Origen himself recovered part of a seventh, containing only the Psalms.

Now Origen, who had held frequent disputations with the Jews in Egypt and Palestine, observing that they always objected against those passages of Scripture quoted against them, and appealed to the Hebrew text; the better to vindicate those passages, and confound the Jews by showing that the Seventy had given the sense of the Hebrew, or rather to show by a number of different versions what the real sense of the Hebrew was, undertook to reduce all those several versions into a body along with the Hebrew text, so as they might be easily confronted, and afford a mutual light to each other.

He made the Hebrew text his standard: and allowing that corruptions might have happened, and that the old Hebrew copies might and did read differently, he contented himself with marking such words or sentences as were not in his Hebrew text, nor the later Greek versions, and adding such words or sentences as were omitted in the Seventy, prefixing an asterisk to the additions, and an obelisk to the others.

In order to this, he made choice of eight columns: in the first he gave the Hebrew text in Hebrew characters; in the second the same text in Greek characters; the rest were filled with the several versions above mentioned; all the columns answering verse for verse, and phrase for phrase; and in the Psalms there was a ninth column for the seventh version.

This work Origen called *Ἑξαπλά*, *Hexapla*, q. d. *sex-tuple*, or work of six columns, as only regarding the first six Greek versions. See TETRAPLA.

Indeed, St Epiphanius, taking in likewise the two columns of the text, calls the work *Octapla*, as consisting of eight columns.

This celebrated work, which Montfaucon imagines consisted of fifty large volumes, perished long ago, probably with the library at Cæsarea, where it was preserved in the year 653; though several of the ancient writers have preserved us pieces thereof: particularly St Chrysostom on the Psalms, Philoponus in his *Hexameron*, &c. Some modern writers have earnestly endeavoured to collect fragments of the *Hexapla*, particularly Flaminus Nobilius, Drusius, and F. Montfaucon, in two folio volumes, printed at Paris in

1713.

VOL. X. Part II.

†

HEXASTYLE, in *Architecture*, a building with six columns in front.

HEXHAM, a town of Northumberland, situated near the conflux of the north and south Tyne. It is commonly supposed to be the *Alexodunum* of the Romans, where the first cohort of the Spaniards were in garrison. It was made a bishop's see by Etheldreda, wife of King Egfred, in the year 675. Its first bishop St Wilfred built here a most magnificent cathedral and monastery, and it was possessed by seven bishops successively; but being very much infested by the Danes, the see was removed to York. The town and priory were destroyed by the Scots in 1296, and pillaged again in 1346. There was a remarkable and bloody battle fought near this town between the houses of Lancaster and York, wherein the former were defeated, chiefly by the extraordinary bravery and conduct of John Nevil, Lord Montacute, who was for that reason created earl of Northumberland. The present town is not populous, and the streets are narrow, with ill built houses. The market-place, near the centre of the town is a spacious square, and is supplied by a fountain with water. Among the remains of ancient structures is a gateway of ancient architecture, leading to the priory, but of a much older date. There are two ancient towers in the town, one of which is used as a sessions-house, and was formerly an exploratory tower; the other is on the top of a hill towards the Tyne, of remarkable architecture, which has been much higher than at present, and has two dungeons within it, besides several chambers with very little narrow windows. The town has a charity or grammar-school. It was in 1571 annexed to the county of Cumberland: but only in civil matters; for in its ecclesiastical jurisdiction it is still a peculiar belonging to the archbishop of York; and the common people still call the neighbouring county Hexhamshire. It is a corporation governed by a bailiff, and contained 3518 inhabitants in 1811.

HEYDON, a small well-built town in the east riding of Yorkshire, in that part called *Holderness*, seated on a river that falls into the Humber. It has now but one church, though there are the remains of two more; and had formerly a considerable trade, which is now lost, on account of its being so near Hull. It sends two members to parliament. Population 780 in 1811. W. Long. o. 55. N. Lat. 53. 46.

HEYDON, *John*, who sometimes assumed the name of *Eugenius Theodidactus*, was a great pretender to skill in the Rosicrucian philosophy and the celestial signs, in the reign of King Charles I.; and wrote a considerable number of chemical and astrological works, with very singular titles. This ridiculous author was much resorted to by the duke of Buckingham, who was infatuated with judicial astrology. He employed him to calculate the king's and his own nativity, and was assured that his stars had promised him great things. The duke also employed Heydon in some treasonable and seditious practices, for which he was sent to the Tower. He lost much of his former reputation by telling Richard Cromwell and Thurloe, who went to him disguised like cavaliers, that Oliver would infallibly be hanged by a certain time; this period, however, he out-lived several years.

HELIN, DR PETER, an eminent English writer,

3 M

was

Heylin,
Heywood

was born at Burford, in Oxfordshire, in 1600. He studied at Hart Hall, Oxford; where he took his degrees in arts and divinity, and became an able geographer and historian. He was appointed one of the chaplains in ordinary to King Charles I.; was presented to the rectory of Hemingford in Huntingdonshire, made a prebendary of Westminster, and obtained several other livings: but of these he was deprived by the parliament, who also sequestered his estate; by which means he and his family were reduced to great necessity. However, upon the Restoration, he was restored to his spiritualities; but never rose higher than to be subdean of Westminster. He died in 1662; and was interred in St Peter's church in Westminster, where he had a neat monument erected to his memory. His writings are very numerous: the principal of which are, 1. *Microcosmus*, or a description of the Great World. 2. *Cosmographia*. 3. The history of St George. 4. *Ecclesia Vindicata*, or the church of England Justified. 5. Historical and Miscellaneous Tracts, &c.

HEYNE, CHRISTIAN GOTLOB, a late eminent German classical scholar. See SUPPLEMENT.

HEYWOOD, JOHN, an English dramatic poet, was born at North-Mims, near St Alban's in Hertfordshire, and educated at Oxford. From thence he retired to the place of his nativity; where he had the good fortune to become acquainted with Sir Thomas More, who, it seems, had a seat in that neighbourhood. This patron of genius introduced our comic poet to the princess Mary, and afterwards to her father Henry, who, we are told, was much delighted with his wit and skill in music, and by whom he was frequently rewarded. When his former patroness, Queen Mary, came to the crown, Heywood became a favourite at court, and continued often to entertain her majesty, *exercising his fancy before her, even to the time that she lay languishing on her deathbed*. On the accession of Elizabeth, being a zealous Papist, he thought fit to decamp, with other favourites of her deceased majesty. He settled at Mechlin in Flanders, where he died in the year 1565.—John Heywood was a man of no great learning, nor were his poetical talents by any means extraordinary; but he possessed talents of more importance in the times in which he lived, namely, the talents of a jester. He wrote several plays; 500 epigrams; *A Dialogue in Verse concerning English Proverbs*; and *The Spider and Fly, a Parable*, a thick 4to. Before the title of this last work is a whole length wooden print of the author; who is also represented at the head of every chapter in the book, of which there are 77.—He left two sons, who both became Jesuits and eminent men: viz. Ellis Heywood, who continued some time at Florence under the patronage of Cardinal Polo, and became so good a master of the Italian tongue, as to write a treatise in that language, entitled *Il Moro*; he died at Louvain about the year 1572. His other son was Jasper Heywood, who was obliged to resign a fellowship at Oxford on account of his immoralities: he translated three tragedies of Seneca, and wrote various poems and devises. He died at Naples in 1597.

HEYWOOD, *Eliza*, a voluminous novel writer; of whom no more is known than that her father was a tradesman, and that she was born about the year 1696. In the early part of her life, her pen, whether to gra-

tify her own disposition or the prevailing taste, dealt chiefly in licentious tales, and memoirs of personal scandal: the celebrated *Atalantis* of Mrs Manley served her for a model; and *The Court of Carimania*, *The new Utopia*, with some other pieces of a like nature, were the copies her genius produced. She also attempted dramatic writing and performance, but did not succeed in either. Whatever it was that provoked the resentment of Pope, he gave full scope to it by distinguishing her as one of the prizes to be gained in the games introduced in honour of Dullness, in his *Dunciad*. Nevertheless, it seems undeniable, that there is much spirit, and much ingenuity, in her manner of treating subjects, which the friends of virtue may perhaps wish she had never meddled with at all. But, whatever offence she may have given to delicacy or morality in her early works, she appears to have been soon convinced of, and endeavoured to atone for in the latter part of her life; as no author then appeared a greater advocate for virtue. Among her riper productions may be specified, *The Female Spectator*, 4 vols; *The History of Miss Betty Thoughtless*, 4 vols; *Jemmy and Jenny Jessamy*, 3 vols; *The Invisible Spy*, 3 vols; with a pamphlet, entitled *A Present for a Servant Maid*. She died in 1759.

HIAMEN, or EMOUY. See EMOUY.

HIATUS, properly signifies an opening, chasm, or gap; but it is particularly applied to those verses where one word ends with a vowel, and the following word begins with one, and thereby occasions the mouth to be more open, and the sound to be very harsh.

The term *hiatus* is also used in speaking of manuscripts, to denote their defects, or the parts that have been lost or effaced.

HIBISCUS, SYRIAN MALLOW, a genus of plants belonging to the monodelphia class, and in the natural method ranking under the 37th order, *Columnifera*. See BOTANY *Index*.

HICETAS of Syracuse, an ancient philosopher and astronomer, who taught that the sun and stars were motionless, and that the earth moved round them. This is mentioned by Cicero, and probably gave the first hint of the true system to Copernicus. He flourished 344 B. C.

HICKES, GEORGE, an English divine of extraordinary parts and learning, was born in 1642. In 1681 he was made king's chaplain, and two years after dean of Worcester. The death of Charles II. stopped his farther preferment; for though his church principles were very high, he manifested too much zeal against Popery to be any favourite with James II. On the revolution, he with many others was deprived for refusing to take the oaths to King William and Queen Mary; and soon after, Archbishop Sancroft and his colleagues considering how to maintain episcopal succession among those who adhered to them, Dr Hickes carried over a list of the deprived clergy to King James; and with his sanction a private consecration was performed, at which it is said Lord Clarendon was present. Among others, Dr Hickes was consecrated suffragan bishop of Thetford, and died in 1715.—He wrote, 1. *Institutiones Grammaticæ Anglo-Saxonicæ, et Mæso-Gothicæ*. 2. *Antiqua literatura septentrionalis*. 3. Two treatises, one of the Christian priesthood, the other of the dignity of the

Heywood
Hickes.

the episcopal order. 4. Jovian, or an answer to Julian the apostate. 5. Sermons; with many temporary controversial pieces on politics and religion.

HICKUP, or **HICCOUGH**, a spasmodic affection of the stomach, œsophagus, and muscles subservient to deglutition, arising sometimes from some particular injury done to the stomach, œsophagus, diaphragm, &c. and sometimes from a general affection of the nervous system. See *MEDICINE Index*.

HIDAGE (*Hidagium*), was an extraordinary tax payable to the kings of England for every hide of land. This taxation was levied not only in money, but in provision, armour, &c.; and when the Danes landed in Sandwich in 994, King Ethelred taxed all his lands by hides; so that every 310 hides found one ship furnished, and every eight hides furnished one jack and one saddle, to arm for the defence of the kingdom, &c. Sometimes the word *hidage* was used for the being quit of that tax; which was also called *hidegild*; and interpreted, from the Saxon, "a price or ransom paid to save one's skin or hide from beating."

HIDALGO, in modern history, a title given in Spain to all who are of a noble family.

The *Hidalgos* claim a descent from those valiant soldiers who retired into Castile, and the mountains of Asturias, and other remote parts of Spain, on the invasion of the Moors, where having fortified themselves, they successively descended into the plains, in proportion to the success of their arms; from the notoriety of their persons, or the lands they became possessed of, they acquired the appellation of *Hidalgos notorios*, *Hidalgos de solar conocido*, or *de casa solariega*. Of these, according to Hernando Mexia, there are three sorts; the first being lords of places, villages, towns, or castles, from whence they took their surnames, as the Guzmans, Mendozas, Laras, Guivras, and others; the second, who recovered any fortress from the Moors, as the Ponces of Leon, and others; and the third sort from the places where they resided, or held jurisdiction, as Rodrigo de Navarez was called of Antequera, from being alcaide there. But this definition is not considered as exact or conclusive by Otalora, another civilian, who says that the true meaning of *Hidalgos de solar conocido* is explained by the laws of Castile to be a well known mansion or possession, the nature of which is particularly explained in the laws of *Parditas*, lib. v. tit. 35. which describe three sorts of tenures, called *Devisa*, *Solariega*, and *Behetria*. By the first, lands are devised by the ancestor; *solar* is a tenure upon another person's manor, and obliges the owner to receive the lord of the fee when necessity obliges him to travel; and *Behetria* is in the nature of an *alodium*. In proportion as these Aborigines gained ground on the Moors, and increased in their numbers, many private persons distinguished themselves by their valour, and obtained testimonies of their services called *cartas de merced*, which served them as a foundation of their birth and good descent, without which documents their posterity could not make it appear; and if from a lapse of time, or other unavoidable accidents, such proof should happen to be lost or destroyed, the law affords them a remedy under these circumstances, by a declaration importing, that such persons as are supposed to have had such certificates, may be relieved by making it appear that their ancestors, time imme-

morial, have always been held and reputed as *Hidalgos*, and enjoyed the privileges of such, form a strong presumption in their favour; the possession of land having equal force to any other document; which is fully set forth in the *Pragmatica* of Cordova. To these executory letters are granted, *cartas executorias*, expressive of their privileges; and for the better regulation of these matters, proper officers are appointed in the chancery courts, called *alcaldes de los hidalgos*, who ought to be *hidalgos* themselves, and hold jurisdiction in these cases, and no others; but even here innovations have taken place; for as these grants flow from the sovereign, who is the fountain of honour, some are declared *Hidalgos de sangre*, by right of descent, and others *de privilegio*, or by office, in which the will of the sovereigns has made amends for any deficiency of blood.

There is a set of people near Segovia, at a place called Zamarramala, who are exempt from tribute on account of the care they take in sending proper persons every night to the castle of Segovia to keep sentinels; one cries out, *Vela, vela, hao*, and the other blows a horn, from whence they have been titled *hidalgos by the horn*. In Catalonia these gentlemen who are styled *Hombre de Pareja*, are considered the same as *hidalgos* in Castile, and were so called from the word *parejar*, to equip, this name being given as a distinction by Borela the fourth count of Barcelona, at the siege of that city, in 965, who summoning all his vassals to come to his assistance against the Moors, nine hundred horsemen well mounted and equipped joined him, and with their aid he took the city; and this appellation has been given in honourable remembrance of this loyal action.

These noble *hidalgos* enjoy many privileges and distinctions; of which the following are the principal:

1. The first and greatest privilege which they hold by law, is to enjoy all posts of dignity and honour in the church and state, with liberty, when churchmen, of having a plurality of benefices. They are qualified for receiving all orders of knighthood, and are to be preferred in all embassies, governments, and public commissions.

2. When they are examined as witnesses in civil and criminal cases, their depositions are to be taken in their own houses, without being obliged to quit them to go to those of others.

3. In all churches, processions, and other public acts or assemblies, they are to have the next place of honour and precedence after the officers of justice, conforming themselves to particular customs.

4. They are not obliged to accept of any challenge for combat, supposing such were allowed of, but from those who are their equals.

5. Though it is forbidden to guardians to purchase the estates of minors, this does not extend to *Hidalgos*, in whom the law does not suppose any fraud, and they may purchase them publicly.

6. They are permitted to be seated in courts of justice in presence of the judges, from the respect and honour due to them. They have also seats in the courts of chancery, in consideration of their birth, which gives them a right to be near the persons of princes.

Hidalgo.

7. Their persons are free from arrest for debt, nor can any attachment be laid on their dwelling-houses, furniture, apparel, arms, horses, or mules in immediate use: nor can they make a cession of their estates, nor be distressed in suits of law, farther than their circumstances will admit of, but are to be allowed a reasonable and decent maintenance for their support.

8. In cases of imprisonment for criminal matters, they are to be treated differently from others. They are generally confined to their own houses with a safe-guard, or under arrest upon their honour, or allowed the city or town they live in, and in particular cases are sent into castles.

9. When punishments are inflicted for criminal cases, they are to be less severe to them than to others, as they are not to suffer ignominious punishments, such as public shame, whipping, galls; nor are they to be hanged, but beheaded, excepting in cases of treason or heresy. In cases that do not imply a corporal punishment but a pecuniary one, they are treated with more rigour, and pay a larger fine than others.

10. They are not to be put to the rack or torture, excepting for such heinous crimes as are particularly specified by the laws.

11. When there are title-deeds or other writings or papers in which two or more persons have an equal right or property, and require a particular charge, they are to be given up by preference to the custody of an Hidalgo, if any of the parties are such.

12. The daughter of an Hidalgo enjoys every privilege of her birth, though married to a commoner; and a woman who is not an Hidalgo enjoys all these privileges when she is a widow, following the fortune of her husband.—But if the widow is an Hidalgo, and the late husband was a commoner, she falls into the state of her husband after his death, though she had the privileges of her birth during his life.

13. They are free from all duties, called *Pechos*, *Pedidos*, *Monedas*, *Marteniegas*, *Contribuciones*, as well royal as civil, and all other levies of whatever kind they may be, with a reserve for such as are for the public benefit, in which they are equally concerned, such as the repairing the highways, bridges, fountains, walls, destruction of locusts, and other vermin.

14. They are free from personal service, and from going to the wars, excepting when the king attends in person; even then they are not to be forced, but invited, and acquainted that the royal standard is displayed.

15. No persons whatever can be quartered upon, or lodged in their houses, except when the king, queen, prince or infant are on the road, as in such cases even the houses of the clergy are not exempt.

16. They cannot be compelled to accept of the office of receiver of the king's rents, or any other employment which is considered as mean and derogatory to their dignity and rank.

17. By a particular custom confirmed by royal authority, in that part of Castile beyond the Ebro, bastards succeed to their parents, and enjoy their honours, contrary to the royal and common law.

18. If a lady, who marries a commoner, should be a queen, duchess, marchioness, or countess (for they have no barons in Castile), she not only does not lose

her rank, but conveys her titles to her husband, who hold them in right of his wife.

These are the general privileges which the Hidalgos enjoy; there are some others of less consequence, as well as particular grants to certain persons and families. An ancient and ridiculous custom is said to be observed by noble ladies who are widows of plebeians, in order to recover their birthright, for which purpose they carry a pack saddle on their shoulders to their husband's grave, then throwing it down and striking it three times, say, 'Villein, take thy villeiny, for I will abide by my nobility:' and then they recover their privileges again.

HIDE, the skin of beasts; but the word is particularly applied to those of large cattle, as bullocks, cows, horses, &c.

Hides are either raw or green, just as taken off the carcase; salted, or seasoned with salt, alum, and saltpetre, to prevent their spoiling; or curried and tanned. See TANNING.

HIDE of Land; was such a quantity of land as might be ploughed with one plough within the compass of a year, or as much as would maintain a family; some call it 60, some 80, and others 100 acres.

HIDE-Bound, a disease in the skin of horses. See FARRIERY.

HIERACIUM, HAWKWEEED, a genus of plants belonging to the syngenesia class; and in the natural method ranking under the 49th order, *Compositæ*. See BOTANY *Index*.

HIERACITES, in church-history, Christian heretics in the third century; so called from their leader Hierax, a philosopher of Egypt: who taught that Melchisedeck was the Holy Ghost, denied the resurrection, and condemned marriage.

HIERANOSIS, or MORBUS SACER. See MEDICINE *Index*.

HIERA PICRA. See PHARMACY *Index*.

HIERAPOLIS, in *Ancient Geography*, a town of Phrygia, abounding in hot springs; and having its name from the number of its temples. There are coins exhibiting figures of various gods who had temples here. Of this place was Epictetus the Stoic philosopher.—It is now called *Pambouk*; and is situated near the Scamander, on a portion of Mount Mesogis, distant six miles from Laodicea.—Its site appears at a distance as a white lofty cliff; and upon arriving at it, the view which it presents is so marvellous (says Dr Chandler), that the description of it, to bear even a faint resemblance, ought to appear romantic. Dr Chandler's description is as follows:

"The vast slope which at a distance we had taken for chalk, was now beheld with wonder, it seeming an immense frozen cascade, the surface wavy, as of water at once fixed, or in its headlong course suddenly petrified. Round about us were many high, bare, stony ridges; and close by our tent, one with a wide basis, and a slender rill of water, clear, soft, and warm, running in a small channel on the top. A woman was washing linen in it, with a child at her back; and, beyond were cabins of the Turcomans, standing distinct, much neater than any we had seen, each with poultry feeding, and a fence of reeds in front.

"It is an old observation, that the country about the Meander,

Hidalgo
Hieracit.Travels in
Asia Minor,
p. 229.

Hierapolis. Meander, the soil being light and friable, and full of salts generating inflammable matter, was undermined by fire and water. Hence it abounded in hot springs, which, after passing under ground from the reservoirs, appeared on the mountain, or were found bubbling up in the plain or in the mud of the river: and hence it was subject to frequent earthquakes; the nitrous vapour compressed in the cavities, and sublimed by heat for fermentation, bursting its prison with loud explosions, agitating the atmosphere, and shaking the earth and waters with a violence as extensive as destructive; and hence, moreover, the pestilential grottoes, which had subterraneous communication with each other, derived their noisome effluvia; and serving as small vents to these furnaces or hollows, were regarded as apertures of hell, as passages for deadly fumes rising up from the realms of Pluto. One or more of the mountains perhaps has burned. It may be suspected, that the surface of the country has in some places been formed from its own bowels: and in particular, it seems probable, that the hill of Laodicea was originally an eruption.

"The hot waters of Hierapolis have produced that most extraordinary phenomenon, the cliff, which is one entire incrustation. They were anciently renowned for this species of transformation. It is related, they changed so easily, that being conducted about the vineyards and gardens, the channels became long fences, each a single stone. They produced the ridges by our tent. The road up to the ruins, which appears as a wide and high causeway, is a petrification; and overlooks many green spots, once vineyards and gardens, separated by partitions of the same material. The surface of the flat, above the cliff, is rough with stone and with channels, branching out in various directions, a large pool overflowing and feeding the numerous rills, some of which spread over the slope as they descend, and give to the white stony bed a humid look, resembling salt or driven snow when melting. This crust, which has no taste or smell, being an alkaline substance, will ferment with acids; and Picerini relates, that trial of it had been made with spirit of vitriol. The waters, though hot, were used in agriculture.

"Tamerlane, when he invaded this country, encamped for the summer at Tangzlik, where many of his men were destroyed by drinking of a spring which stagnated and petrified. The Turkish name Pambouk signifies *cotton*; and, it has been said, refers to the whiteness of the incrustation.

"The shepherd-poet of Smyrna, after mentioning a cave in Phrygia sacred to the Nymphs, relates, that there Luna had once descended from the sky to Endymion, while he was sleeping by his herds; that marks of their bed were then extant under the oaks; and that in the thickets around it the milk of cows had been spilt, which men still beheld with admiration (for such was the appearance if you saw it very far off); but that from thence flowed clear or warm water, which in a little while concreted round about the channels, and formed a stone pavement. The writer describes the cliff of Hierapolis, if I mistake not, as in his time; and has added a local story, current when he lived. It was the genius of the people to unite fiction with truth; and, as in this and other instances, to dignify the tales of their mythology with fabulous evidence taken

from the natural wonders in which their country abounded. **Hierapolis.**

"We ascended in the morning to the ruins, which are on a flat, passing by sepulchres with inscriptions, and entering the city from the east. We had soon the theatre on our right hand, and the pool between us and the cliff. Opposite to it, near the margin of the cliff, are the remains of an amazing structure, once perhaps baths, or, as we conjectured, a gymnasium; the huge vaults of the roof striking horror as we rode underneath. Beyond it is the mean ruin of a modern fortress; and farther on are massive walls of edifices, several of them leaning from their perpendicular, the stones distorted, and seeming every moment ready to fall; the effects and evidences of violent and repeated earthquakes. In a recess of the mountain on the right hand is the area of a stadium. Then again sepulchres succeed, some nearly buried in the mountain side, and one, a square building, with an inscription in large letters. All these remains are plain, and of the stone created by the waters. The site has been computed about two hundred paces wide and a mile in length.

"After taking a general survey, we returned to the theatre, intending to copy inscriptions; and examine more particularly as we changed our station. We found this a very large and sumptuous structure, and the least ruined of any we had seen. Part of the front is standing. In the heap which lies in confusion, are many sculptures well executed in basso relievo: with pieces of architrave inscribed, but disjointed; or so encumbered with massive marbles, that we could collect from them no information. The character is large and bold, with ligatures. The marble seats are still unremoved. The numerous ranges are divided by a low semicircular wall, near mid way, with inscriptions on the face of it, but most illegible. I copied a short but imperfect one, in which Apollo Archegetes or *The Leader* is requested to be propitious. In another compartment, mention is made of the city by its name *Hierapolis*; and on a third is an encomium in verse, which may be thus translated, 'Hail, golden city Hierapolis, the spot to be preferred before any in wide Asia; revered for the rills of the Nymphs; adorned with splendor.' The Nymphs presided over springs and fountains.

"After attentively viewing them, and considering their height, width, and manner of arrangement, I am inclined to believe, that the ancient Asiatics sat at their plays and public spectacles like the modern, with their legs crossed or gathered under them; and it is probable upon carpets.

"The waters of Hierapolis, were surprisingly attempted for tinging wool, with a colour from roots rivaling the more costly purples; and were a principal source of the riches of the place. The company of dyers is mentioned in the inscription on the square building among the sepulchres. The heroum or monument was to be crowned by them with garlands or festoons of flowers. The springs flowed so copiously, that the city was full of spontaneous baths; and Apollo, the tutelary deity of the Hierapolitans, with Æsculapius and Hygiæa, on their medals, bear witness to the medicinal virtues which they possess. The people, in some of their inscriptions, are styled the *most splendid*, and the *sovereigns the most powerful*.

"The

Hierapolis

Hieros.

"The pool before the theatre has been a bath, and marble fragments are visible at the bottom of the water, which is perfectly transparent, and of a briny taste.

"Hierapolis was noted, besides its hot waters, for a plutonium. This was an opening in a small brow of the adjacent mountain, capable of admitting a man, and very deep, with a square fence before it, inclosing about half an acre; which space was filled with black thick mist, so that the bottom could be scarcely discerned. The air, to those who approached it, was innocent on the outside of the fence, being clear of the mist in serene weather, it remaining then within the boundary; but there death abode. Bulls, as at Nysa, dropt down, and were dragged forth without life; and some sparrows which Strabo let fly instantly fell senseless. But eunuchs, the priests of Magna Mater, or Cybele, could go in quite to the aperture, lean forward, or enter it unharmed; but they held their breath, as their visages testified, and sometimes until in danger of suffocation. Strabo, the relater, was in doubt whether all eunuchs could do this, or only they of the temple; and whether they were preserved by Divine Providence, as in cases of enthusiasm, or were possessed of some powerful antidotes. But it is likely this mist was the condensed steam of the hot waters, made noxious by the qualities of the soil; and that the whole secret of the priests consisted in carrying their faces high in the air, as another spectator has observed they always did; and in avoiding respiration when they stooped. I had hoped the description of this spot would have enabled me to find it, but I searched about for it unsuccessfully.

"We descended to our tent at the approach of evening by a steep track down the cliff, beginning beyond the pool, in which we also bathed with pleasure, on the side next the gymnasium. Our way was often rough and slippery, resembling ice, and our horses with difficulty preserved their footing. When arrived at our tent, I renewed my inquiries for the plutonium; and an old Turk, with a beard as white as snow, told me he knew the place, that it was often fatal to their goats; and accounting for the effect, said, it was believed to be the habitation of a *dæmon* or evil spirit. We ascended again early in the morning to the theatre, where he had promised to join us; and a live fowl was intended to be the martyr of experiment." But our author was interrupted by some banditti, and obliged to leave Hierapolis in haste.

HIERARCHY, among divines, denotes the subordination of angels.

Some of the rabbins reckon four, others ten, orders or ranks of angels; and give them different names according to their different degrees of power and knowledge.

HIERARCHY, likewise denotes the subordination of the clergy, ecclesiastical polity, or the constitution and government of the Christian church considered as a society.

HIERS, the name of some small islands lying near the coast of Provence in France, opposite to the towns of Hieres and Toulon, where the English fleet lay many months in 1744, and blocked up the French and Spanish fleets in the harbour of Toulon.

HIERS, a town of Provence in France, seated on the Mediterranean sea. It is a pretty little town, and was

formerly a colony of the Marsilians; and pilgrims used to embark here for the holy land. But its harbour being now choked up, it is considerable only for its salt-works. E. Long. 6. 13. N. Lat. 43. 7.

HIERO I. and II. kings of Syracuse. See SYRACUSE.

HIROCLES, a cruel persecutor of the Christians, and a violent promoter of the persecution under Dioclesian, flourished in 302. He wrote some books against the Christian religion; in which he pretends some inconsistencies in the Holy Scriptures, and compares the miracles of Apollonius Tyanæus to those of our Saviour. He was refuted by Lactantius and Eusebius. The remains of his works were collected into one volume octavo, by Bishop Pearson; and published in 1654, with a learned dissertation prefixed to the work.

HIROCLES, a Platonic philosopher of the fifth century, taught at Alexandria, and was admired for his eloquence. He wrote seven books upon Providence and Fate: and dedicated them to the philosopher Olympiodorus, who by his embassies did the Romans great service under the emperors Honorius and Theodosius the younger. But these books are lost, and we only know them by the extracts in Photius. He wrote also a Commentary upon the golden verses of Pythagoras; which is still extant, and has been several times published with those verses.

HIROGLYPHICS, in antiquity, mystical characters, or symbols, in use among the Egyptians, and that as well in their writings as inscriptions; being the figures of various animals, the parts of human bodies, and mechanical instruments. The word is composed of the Greek *hieros*, sacer, "holy," and *glyphos*, *sculpsere*, "to engrave;" it being the custom to have the walls, doors, &c. of their temples, obelisks, &c. engraven with such figures.

Hieroglyphics are properly emblems or signs of divine, sacred, or supernatural things; by which they are distinguished from common symbols, which are signs of sensible and natural things.

Hermes Trismegistus is commonly esteemed the inventor of hieroglyphics: he first introduced them into the heathen theology, from whence they have been translated into the Jewish and Christian.

Sacred things, says Hippocrates, should only be communicated to sacred persons. Hence it was that the ancient Egyptians communicated to none but their kings and priests, and those who were to succeed to the priesthood and the crown, the secrets of nature, and the secrets of their morality and history; and this they did by a kind of cabbala, which, at the same time that it instructed them, only amused the rest of the people. Hence the use of hieroglyphics, or mystic figures, to veil their morality, politics, &c. from profane eyes. This author, it may be observed, and many others, do not keep to the precise character of a hieroglyphic, but apply it to profane as well as divine things.

Hieroglyphics are a kind of real character, which do not only denote, but in some measure express, the things. Thus, according to Clemens Alexandrinus, Strom. v. a lion is the hieroglyphic of strength and fortitude; a bullock, of agriculture; a horse, of liberty; a sphinx, of subtilty, &c.

Hieros

Hieroglyphic.

Such

erogly-
phics.

Such is the opinion that has generally been embraced both by ancient and modern writers, of the origin and use of hieroglyphics. It has been almost uniformly maintained, that they were invented by the Egyptian priests in order to conceal their wisdom from the knowledge of the vulgar; but the late Bishop Warburton hath, with much ingenuity and learning, endeavoured to show that this account is erroneous.

According to this writer, the first kind of hieroglyphics were mere pictures, because the most natural way of communicating our conceptions by marks or figures was by tracing out the images of things; and this is actually verified in the case of the Mexicans, whose only method of writing their laws and history was by this picture-writing. But the hieroglyphics invented by the Egyptians were an improvement, on this rude and inconvenient essay towards writing, for they contrived to make them both pictures and characters. In order to effect the improvement, they were obliged to proceed gradually, by first making the principal circumstance of the subject stand for the whole; as in the hieroglyphics of Horapollon, which represent a battle of two armies in array by two hands, one holding a shield and the other a bow: then putting the instrument of the thing, whether real or metaphorical, for the thing itself, as an eye and sceptre to represent a monarch, a ship and pilot the governor of the universe, &c.: and finally, by making one thing stand for or represent another, where their observations of nature or traditional superstitions led them to discover or imagine any resemblance: thus, the universe was designed by a serpent in a circle, whose variegated spots denoted the stars; and a man who had nobly surmounted his misfortune was represented by the skin of the hyena, because this was supposed to furnish an invulnerable defence in battle.

The Chinese writing, he observes, was the next kind of improvement in the use of hieroglyphics. The Egyptians joined characteristic marks to images; the Chinese threw out the images and retained only the contracted marks, and from these marks proceeded letters. The general concurrence of different people in this method of recording their thoughts can never be supposed to be the effect of imitation, sinister views, or chance; but must be considered as the uniform voice of nature speaking to the rude conceptions of mankind: for not only the Chinese of the East, the Mexicans of the West, and the Egyptians of the South, but the Scythians likewise of the North, and the intermediate inhabitants of the earth, viz. the Indians, Phœnicians, Ethiopians, &c. used the same way of writing by picture and hieroglyphic.

The bishop farther shows, that the several species of hieroglyphic writing took their rise from nature and necessity, and not from choice and artifice, by tracing at large the origin and progress of the art of speech. He proceeds to show how in process of time the Egyptian hieroglyphics came to be employed for the vehicle of mystery. They used their hieroglyphics two ways; the one more simple, by putting the part for the whole, which was the curiologic hieroglyphic; and the other more artificial, by putting one thing of resembling qualities for another, called the tropical hieroglyphic; thus the moon was sometimes represented by a half circle and sometimes by a cynocephalus. They em-

ployed their proper hieroglyphics to record openly and plainly their laws, policies, public morals, and history, and all kinds of civil matters: this is evident from their obelisks, which are full of hieroglyphic characters, designed to record singular events, memorable actions, and new inventions; and also from the celebrated inscription on the temple of Minerva, at Saïs, where an infant, an old man, a hawk, a fish, and a river-horse, expressed this moral sentence: "All you who come into the world and go out of it, know this, that the gods hate impudence." However, the tropical hieroglyphics, which were employed to divulge, gradually produced symbols which were designed to secrete or conceal: thus Egypt was sometimes expressed by the crocodile, sometimes by a burning censer with a heart upon it; where the simplicity of the first representation and the abstruseness of the latter show, that the one was a tropical hieroglyphic for communication, and the other a tropical symbol invented for secrecy.

Enigmatic symbols were afterwards formed by the assemblage of different things, or of their properties that were less known; and though they might have been intelligible at first; yet when the art of writing was invented, hieroglyphics were more generally disused, the people forgot the signification of them, and the priests, retaining and cultivating the knowledge of them because they were the repositories of their learning and history, at length applied them to the purpose of preserving the secrets of their religion.

Symbols were the true original of animal-worship in Egypt, as Sir John Marsham conjectures; *Can. Chron.* p. 58. because in these hieroglyphics was recorded the history of their greater deities, their kings, and lawgivers, represented by animals and other creatures. The symbol of each god was well known and familiar to his worshippers, by means of the popular paintings and engravings on their temples and other sacred monuments; so that the symbol presenting the idea of the god, and that idea exciting sentiments of religion, it was natural for them; in their addresses to any particular god, to turn to his representative mark or symbol; especially when we consider farther, that the Egyptian priests feigned a divine original for hieroglyphic characters, in order to increase the veneration of the people for them. These would of course bring on a relative devotion to these symbolic figures, which, when it came to be paid to the living animal, would soon terminate in an ultimate worship.

Another consequence of the sacredness of the hieroglyphic characters was, that it disposed the more superstitious to engrave them on gems, and wear them as amulets or charms. This magical abuse seems not to have been much earlier than the established worship of the god Serapis, which happened under the Ptolemies, and was first brought to the general knowledge of the world by certain Christian heretics and natives of Egypt, who had mixed a number of Pagan superstitions with their Christianity. These gems, called *abrasas*, are frequently to be met with in the cabinets of the curious, and are engraven with all kinds of hieroglyphic characters. To these *abrasas* succeed the talismans.

HIEROGRAMMATISTS; (*Hierogrammatæ*), i. e. holy registers, were an order of priests among the

Hierogly-
phics,
Hierogram-
matists.

Hierogrammatists—ancient Egyptians, who presided over learning and religion. They had the care of the hieroglyphics, and were the expositors of religious doctrines and opinions. They were looked upon as a kind of prophets; and it is pretended, that one of them predicted to an Egyptian king, that an Israelite (meaning Moses), eminent for his qualifications and achievements, would lessen and depress the Egyptian monarchy.—The hierogrammatei were always near the king, to assist him with their informations and counsels. The better to fit them for this, they made use of the skill and knowledge they had acquired in the stars and the motions of the heavenly bodies, and even of the writings of their predecessors, wherein their functions and duties were delivered. They were exempted from all civil employments, were reputed the first persons in dignity next the king, and bore a kind of sceptre in form of a ploughshare.—After Egypt became a province of the Roman empire, the hierogrammatei sunk into neglect.

HIEROMANCY, in antiquity, that part of divination which predicted future events from observing the various things offered in sacrifice. See DIVINATION and SACRIFICE.

HIEROMNEMON, among the ancient Greeks, signified a delegate chosen by lot, and sent to the great council of the Amphictyons, where he was to take care of what concerned religion. The hieromnemonies were reckoned more honourable than the other members of that assembly, the general meetings of which were always summoned by them, and their names were prefixed to the decrees made by that council.

HIEROMNEMON (composed of *hieros*, "sacred," and *mnemon*, "one who advertises or puts in mind of"), an officer in the ancient Greek church, whose principal function was to stand behind the patriarch at the sacraments, ceremonies, &c. and show him the prayers, psalms, &c. which he was to rehearse. He also clothed the patriarch in his pontifical robes, and assigned the places of all those who had a right to be around him when seated on his throne, as the master of the ceremonies now does to the pope.

HIERONYMUS. See JEROME.

HIEROPHANTES, or **HIEROPHANTA**, (from *hieros*, *holy*, and *φαινομαι*, *I appear*), in antiquity, a priest among the Athenians.

The hierophantes was properly the chief person that officiated in the Eleusinia, that great solemnity sacred to Ceres.

This office was first executed by Eumolpus, and continued in his family for 1200 years, though when any person was appointed to this dignity he was required always to live in celibacy.

St Jerome says, that the hierophantes extinguished the fire of lust by drinking cicuta or the juice of hemlock, or even by making themselves eunuchs. Apollodorus observes, that it was the hierophantes who instructed persons initiated into their religion in the mysteries and duties thereof, and that it was hence he derived his name: for the same reason he was called *prophetes*, "the prophet." He had officers under him to do the same thing, or to assist him therein, who were also called *prophetes* and *cæges*, i. e. "explainers of divine things."

5

To the hierophantes it belonged to dress and adorn the statues of the gods, and to bear them in processions and solemn ceremonies.

HIEROPHYLAX, an officer in the Greek church who was guardian or keeper of the holy utensils, vestments, &c. answering to our sacrista or vestry-keeper.

HIGH, a term or relation, importing one thing's being superior or above another: thus we say, a *high* mountain, the *high* court of parliament, *high* relieve, &c.

HIGH, in *Music*, is sometimes used in the same sense with *loud*, and sometimes in the same sense with *acute*.

HIGH Dutch, is the German tongue in its greatest purity, &c. as spoken in Misnia, &c.

HIGH Operation, in chirurgery, is a method of extracting the stone; thus called, because the stone is taken out at the upper part of the bladder. See SURGERY.

HIGH Places, were eminences on which the heathens used to worship their gods, chosen for that purpose as being supposed to be nearer heaven their constant residence. The Jews are frequently blamed for their attachment to high places, after the manner of the Gentiles; though their *proseucha* were frequently upon mountains with groves planted about them. Where high-places are reprobated in scripture, therefore, we should understand them as abused and prostituted to idolatrous purposes. Before the temple was built, there was indeed nothing in the high-places very contrary to the law, provided God only was adored there, and that no incense or victims were offered to idols. Under the judges they seem to have been tolerated; and Samuel offered sacrifices in several places besides the tabernacle, where the ark was not present. Even in David's time, they sacrificed to the Lord at Shilo, Jerusalem, and Gibeon; but after the temple was built, and a place prepared for the fixed settlement of the ark, it was no more allowed of to sacrifice out of Jerusalem. Solomon, in the beginning of his reign, went a pilgrimage to Gibeon; but from that time we see no lawful sacrifices offered out of the temple.

HIGH Priest. See PONTIFEX and PRIEST.

HIGH Way, a free passage for the king's subjects: on which account it is called the *king's high way*, though the freehold of the soil belong to the owner of the land. Those ways that lead from one town to another, and such as are drift or cart ways, and are for all travellers in great roads, or that communicate with them, are high ways only; and as to their reparation, are under the care of surveyors.

HIGH-WAY-MEN, are robbers on the high way; for the apprehending and taking of whom, a reward of 40l. is given by the statute of 4 and 5 W. and M. to be paid within a month after conviction by the sheriff of the county; to which the statute 8 Geo. II. cap. 6. superadds 10l. to be paid by the hundred indemnified by such taking.

HIGHAM FERRERS, an ancient borough of Northamptonshire in England, which has its name from the family of the Ferrers, to whom it formerly belonged, and who had a castle in the neighbourhood. It sends one member to parliament. E. Long. 1. 40. N. Lat. 52. 20.

HIGHGATE, a village five miles north of London. It has its name from its high situation, and from

Highgate
Highland-
era.

a gate set up there about 400 years ago, to receive toll for the bishop of London, when the old miry road from Gray's-Inn lane to Barnet was turned through the bishop's park. There was a hermitage where the chapel now stands; and one of the hermits caused a causeway to be made between Highgate and Islington, with gravel dug out of the top of the hill, where there is now a pond. Near the chapel, in 1562, lord chief baron Cholmondely built and endowed a free school, which was enlarged in 1570 by Edwin Sandys bishop of London.—This village is a noted and airy retirement for the gentry and wealthy citizens; and is a place of good accommodation, besides its affording a delightful and pleasant prospect over the city and adjacent country.

HIGHLANDERS, a general appellation for the inhabitants of the mountainous parts of any country. In Britain, the name is appropriated to the people who inhabit the mountainous parts of Scotland, to the north and north-west, including those of the Hebrides or Western isles.—They are a branch of the ancient Celtæ; and undoubtedly the descendants of the first inhabitants of Britain, as appears from the many monuments of their language still retained in the most ancient names of places in all parts of the island. The Highlanders, or, as they are often termed by ancient authors, the *Caledonians*, were always a brave, warlike, and hardy race of people; and, in the remotest times, seem to have possessed a degree of refinement in sentiment and manners then unknown to the other nations that surrounded them. This appears not only from their own traditions and poems, but also from the testimony of many ancient authors. This civilization was probably owing in a great measure to the order of the bards, or Druids, and some other institutions peculiar to this people.

The ancient Highlanders lived in the hunting state till some time after the era of Fingal, who was one of their kings towards the close of the third century. For some ages after that, they turned their chief attention to the pastoral life, which afforded a less precarious subsistence. Till of late, agriculture in most parts of the Highlands made but little progress.

The Highlanders always enjoyed a king and government of their own, till Kenneth M'Alpine (anno 845), after having subdued the Pictish kingdom, transferred thither the seat of royalty. This event proved very unfavourable to the virtues of the Highlanders, which from this period began to decline. The country, no longer awed by the presence of the sovereign, fell into anarchy and confusion. The chieftains began to extend their authority, to form factions, and to foment divisions and feuds between contending clans. The laws were either too feeble to bind them, or too remote to take notice of them. Hence sprung all those evils which long disgraced the country, and disturbed the peace of its inhabitants. Robbery or plunder, providing it was committed on any one of an adverse clan or tribe, was countenanced and authorized; and their reprisals on one another were perpetual. Thus quarrels were handed down from one generation to another, and the whole clan were bound in honour to espouse the cause of every individual that belonged to it. By this means the genius of the people was greatly altered; and the Highlanders of a few ages

VOL. X. Part II.

Highland-
era

back were almost as remarkable for their irregular and disorderly way of life as their predecessors were for their civilization and virtue. It is from not attending to this distinction between the ancient Highlanders and their posterity in later times, that many have doubted the existence of those exalted virtues ascribed by their poets to the more ancient inhabitants of the country. But now that the power of the chieftains is again abolished, law established, and property secured, the genius of the people (where it is not hindered by some other extraneous cause) begins again to show itself in its genuine colours; and many of their ancient virtues begin to shine with conspicuous lustre. Justice, generosity, honesty, friendship, peace, and love, are perhaps nowhere more cultivated than among this people. But one of the strongest features which marked the character of the Highlanders in every age, was their hospitality and benevolence to strangers. At night the traveller was always sure to find a hearty welcome in whatever house he should go to; and the host thought himself happier in giving the entertainment than the guest in receiving it. Even with regard to their enemies, the laws of hospitality were observed with the most sacred regard. They who fought against each other in the day, could in the night feast, and even sleep together, in the same house. From the same principle, they were, in most other cases, so faithful to their trust, that they rarely betrayed any confidence reposed in them. A promise they thought as binding as an oath, and held it equally inviolable and sacred.

The Caledonians in all ages have been much addicted to poetry and music. The poems of Ossian, so universally repeated, and so highly esteemed by every Highlander, are a strong proof of the early proficiency of this people in the poetical art. Even to this day, notwithstanding the many disadvantages they labour under, the most illiterate of either sex discover frequently a genius for poetry, which often breaks forth in the most natural and simple strains, when, love, grief, joy, or any other subject of song, demands it. Wherever their circumstances are so easy as to allow them any respite from toil, or any cheerfulness of spirits, a good portion of their time, especially of the winter-nights, is still devoted to the song and tale. This last species of composition is chiefly of the novel-kind, and is handed down by tradition like their poems. It was the work of the bards; and proved, while they existed, no contemptible entertainment. But since the extinction of that order, both the Gaelic poems and tales are in a great measure either lost or adulterated.—The genius and character of the Gaelic poetry is well known. It is tender, simple, beautiful, and sublime.

Among the ancient Highlanders, the harp was the chief instrument of music. It suited the mildness of their manners, and was well adapted to the peace and quiet which they enjoyed under their own kings. In a later period, however, when the constant quarrels of their chiefs, and the endless feuds of contending clans, turned all their thoughts to war, it was forced to give place to the bag-pipe, an instrument altogether of the martial kind, and therefore well suited to the state of the country at that time. But ever since the cause which has brought this instrument in vogue had ceased

Highland-
ers.

to operate, the attention to it has been on the decline; so that the harp, with very little encouragement, might again resume the seat from which it was once expelled.

—The most, and especially the oldest of the Highland music, having been composed to the harp, is of a soft, tender, and elegiac cast, as best suited to the genius of that instrument. These pieces are generally expressive of the passions of love and grief. Other pieces, which were composed in their state of war, and adapted to a different instrument, are altogether bold and martial. And many are of a sprightly and cheerful cast, the offspring of mirth, and the sport of fancy in the season of festivity. Many of these last are of the chorus kind: and are sung in almost all the exercises in which a number of people are engaged, such as rowing, reaping, fulling, &c. The time of these pieces is adapted to the exercises to which they are respectively sung. They greatly forward the work, and alleviate the labour. The particular music which is generally used by the Highlanders in their dances is well known by the name of *Strathspey reels*.

The language of the Highlanders is still the Gaelic; which, with many of their customs and manners, has been secured to them by their mountains and fastnesses, amidst the many revolutions which the rest of the island has undergone in so long a course of ages. The Gaelic seems to be the oldest and purest dialect which remains of the Celtic, as appears from its approaching the nearest to the names of places, &c. which that language left in most countries where it prevailed, and from its most obvious affinity to those tongues, ancient or modern, which have been in any measure derived from the old Celtic. The Gaelic has all the marks of an original and primitive language. Most of the words are expressive of some property or quality of the objects which they denote. This, together with the variety of its sounds (many of which, especially of those that express the soft and mournful passions, are peculiar to itself), renders it highly adapted for poetry. It is generally allowed to have been the language of court, in Scotland, till the reign of Malcom Canmore. The Gaelic epithet of *Canmore*, or "large head," by which this king is distinguished, seems to intimate so much. In some particular parliaments at least, it was spoken much later, as in that held by Robert the Bruce at Ardochattan. That it has been formerly a good deal cultivated, appears from the style and complexion of its poems and tales, and from several ancient MSS. that have come down to the present time. To strangers the Gaelic has a forbidding aspect, on account of the number of its quiescent consonants (which are retained to mark the derivation of words and their variation in case and tense), but its sound is abundantly musical and harmonious; and its genius strong and masculine. Its alphabet consists of 18 letters, of which one is an aspirate, 12 are consonants, and five are vowels.

The Highlanders are beginning of late to apply to learning, agriculture, and especially to commerce, for which their country, everywhere indented with arms of the sea, is peculiarly favourable. Cattle is the chief staple of the country; but it produces more grain than would supply its inhabitants, if so much of it were not consumed in whisky. The natives are beginning to avail themselves of their mines, woods,

and fisheries; and by a vigorous application, with the due encouragement of government, may become a prosperous and useful people.

Highland-
ers,
Highmore.

The Highlanders are of a quick and penetrating genius, strongly tinged with a curiosity or thirst of knowledge, which disposes them to learn any thing very readily. They are active and industrious, where oppression does not discourage them by secluding even the hope of thriving. They are remarkably bold and adventurous, which qualifies them for being excellent seamen and soldiers. They are generally of a middle size, rather above it than otherwise; their eyes are brisk and lively, their features distinctly marked, and their persons tight and well made. Their countenance is open and ingenuous, and their temper frank and communicative.

HIGHMORE, JOSEPH, Esq. an eminent painter, was born in the parish of St James's, Garlickhithe, London, June 13. 1692, being the third son of Mr Edward Highmore, a coal merchant in Thames-street. Having such an early and strong inclination to painting, that he could think of nothing else with pleasure, his father endeavoured to gratify him in a proposal to his uncle, who was serjeant-painter to King William, and with whom Mr (afterwards Sir James) Thornhill had served his apprenticeship. But this was afterwards for good reasons declined, and he was articulated as clerk to an attorney, July 18th 1707; but so much against his own declared inclination, that in about three years he began to form resolutions of indulging his natural disposition to his favourite art, having continually employed his leisure hours in designing, and in the study of geometry, perspective, architecture, and anatomy, but without any instructors except books. He had afterwards an opportunity of improving himself in anatomy, by attending the lectures of Mr Cheselden, besides entering himself at the painters academy in Great Queen-street, where he drew 10 years, and had the honour to be particularly noticed by Sir Godfrey Kneller, who distinguished him by the name of "The Young Lawyer." On June 13th 1714, his clerkship expired; and on March 26th 1715, he began painting as a profession, and settled in the city. In the same year Dr Brook Taylor published his "Lilinear Perspective: or, a new method of representing justly all manner of objects as they appear to the eye in all situations." On this complete and universal theory our artist grounded his subsequent practice; and it has been generally allowed, that few, if any, of the profession at that time were so thorough masters of that excellent but intricate system. In 1716, he married Miss Susanna Hiller, daughter and heiress of Mr Anthony Hiller of Eppingham in Surrey; a young lady in every respect worthy of his choice. For Mr Cheselden's "Anatomy of the Human Body," published in 1722, he made drawings from the real subjects at the time of dissection, two of which were engraved for that work, and appear, but without his name, in tables xii. and xiii. In the same year, on the exhibition of "The Conscious Lovers," written by Sir Richard Steele, Mr Highmore addressed a letter to the author on the limits of filial obedience, pointing out a material defect in the character of Bevil, with that clearness and precision for which, in conversation and writing, he was always remarkable, as the pencil by no

Highmore. means engrossed his whole attention. His reputation and business increasing, he took a more conspicuous station, by removing to a house in Lincoln's-Inn-Fields, in March 1723-4; and an opportunity soon offered of introducing him advantageously to the nobility, &c. by his being desired, by Mr Pine the engraver, to make the drawings for his prints of the knights of the Bath, on the revival of that order in 1725. In consequence, several of the knights had their portraits also by the same hand, some of them whole lengths; and the duke of Richmond, in particular, was attended by his three esquires, with a perspective view of King Henry VIIIth's chapel. This capital picture is now at Godwood. And our artist was sent for to St James's by George I. to draw the late duke of Cumberland, from which Smith scraped a mezzotinto.

In 1728, Mr Hawkins Browne, then of Lincoln's-Inn, who had ever a just sense of his talents and abilities, addressed to him a poetical epistle "On Design and Beauty;" and, some years after, an elegant Latin Ode, both now collected in his poems. In the summer of 1732, Mr Highmore visited the continent, in company with Dr Pemberton, Mr Benjamin Robins, and two other friends, chiefly with a view of seeing the gallery of pictures belonging to the elector Palatine at Dusseldorp, collected by Rubens, and supposed the best in Europe. At Antwerp also he had peculiar pleasure in contemplating the works of his favourite master. In their return they visited the principal towns in Holland. In 1734, he made a like excursion, but alone, to Paris, where he received great civilities from his countrymen then there, particularly the duke of Kingston, Dr Hickman (his tutor), Robert Knight, Esq. (the late cashier), &c. Here he had the satisfaction of being shown, by Cardinal de Polignac, his famous group of antique statues, the court of Lycomedes, then just brought from Rome, and since purchased by the king of Prussia, and destroyed at Charlottenbourg in 1760 by the Russians. In 1742, he had the honour to paint the late prince and princess of Wales for the duke of Saxe Gotha; as he did some years after the late queen of Denmark for that court. The publication of "Pamela;" in 1744, gave rise to a set of paintings by Mr Highmore, which were engraved by two French engravers, and published by subscription in 1745. In the same year he painted the only original of the late General Wolfe, then about 18. His Pamela introduced him to the acquaintance and friendship of the excellent author whose picture he drew, and for whom he painted the only original of Dr Young. In 1750 he had the misfortune to lose his wife. On the first institution of the academy of painting, sculpture, &c. in 1753, he was elected one of the professors; an honour which, on account of his many avocations, he desired to decline. In 1754 he published "A critical examination of those two Paintings [by Rubens] on the Ceiling of the Banqueting-house at Whitehall, in which Architecture is introduced, so far as relates to Perspective; together with the Discussion of a Question which has been the Subject of Debate among Painters:" printed in 4to. In the solution of this question, he proved that Rubens and several other great painters

Highmore. were mistaken in the practice, and Mr Kirby and several other authors in the theory. And in the 17th volume of the "Monthly Review," he animadverted (anonymously) on Mr Kirby's unwarrantable treatment of Mr Ware, and detected and exposed his errors, even when he exults in his own superior science. Of the many portraits which Mr Highmore painted, in a large practice of 46 years (of which several have been engraved), it is impossible and useless to discuss particulars. Some of the most capital in the historical branch, which was then much less cultivated than it is at present, shall only be mentioned, viz. "Hagar and Ishmael," a present to the Foundling-hospital: "The good Samaritan," painted for Mr Shepherd of Campsey Ash: "The finding of Moses," purchased at his sale by Colonel (now General) Lister: "The Harlowe family, as described in Clarissa," now in the possession of Thomas Watkinson Payler, Esq. at Heden in Kent: "Clarissa," the portrait mentioned in that work: "The Graces unveiling Nature," drawn by memory from Rubens: "The Clementina of Grandison, and the queen mother of Edward IV. with her younger son, &c. in Westminster-abbey;" the three last in the possession of his son.

In 1761, on the marriage of his daughter to the reverend Mr Duncombe, son to one of his oldest friends, he took a resolution of retiring from business, and disposing of his collection of pictures, which he did by auction, in March 1762, and soon after removed to his son-in-law's at Canterbury, where he passed the remainder of his life without ever revisiting the metropolis. But though he had laid down the pencil, he never wanted employment: so active and vigorous was his mind, that, with a constitutional flow of spirits, and a relish for instructive society, he was never less "alone than when alone;" and besides, his professional pursuits above mentioned, to philosophy, both natural and moral, and also to divinity, he laudably dedicated his time and attention. No man had more clearness and precision of ideas, or a more ardent desire to know the truth; and, when known, conscientiously to pursue it. With strong passions, ever guided by the strictest virtue, he had a tender, susceptible heart, always open to the distress of his fellow-creatures, and always ready to relieve them. His capital work of the literary kind was his "Practice of Perspective, on the principles of Dr Brook Taylor," &c. written many years before, but not published till 1763, when it was printed for Nourse, in one vol. 4to. This not only evinced his scientific knowledge of the subject, but removed, by its perspicuity, the only objection, that can be made to the system of Dr Taylor. It accordingly received, from his friends and the intelligent public, the applauses it deserved. In 1765 he published (without his name) Observations on a Pamphlet entitled, "Christianity not founded on Argument;" in which, after showing that it is a continued irony, and lamenting that so ample a field should be offered the author of it for the display of his sophistry; he gives up creeds, articles, and catechisms, as out-works raised by fallible men, and, confining himself to the defence of the gospel, or citadel, shows, that pure primitive Christianity, though assailed by infidels, will ever remain impregnable. His opinion of Rubens may be

Highmore,
Highness.

seen in the Gentleman's Magazine for 1766, p. 353. under the title of "Remarks on some passages in Mr Webb's inquiry into the Beauties of Painting," &c. In the same year he published, with only his initials, "J. H." two small volumes of "Essays, moral, religious, and miscellaneous; with a Translation in prose of Mr Browne's Latin Poem on the Immortality of the Soul:" selected from a large number written at his leisure, at different periods of life. "As such (says Dr Hawkesworth) they do the author great credit. They are not excursions of fancy, but efforts of thought, and indubitable indications of a vigorous and active mind." In the Gentleman's Magazine for 1769, p. 287. he communicated "A natural and obvious Manner of constructing Sun-dials, deduced from the Situation and Motion of the Earth with respect to the Sun," explained by a scheme. And in that for 1778, p. 526. his remarks on colouring, suggested by way of a note on the "Epistle to an eminent Painter," will show that his talents were by no means impaired at the age of 86. Indeed he retained them to the last, and had even strength and spirits sufficient to enable him to ride out daily on horseback the summer before he died. A strong constitution, habitual temperance, and constant attention to his health in youth as well as in age, prolonged his life, and preserved his faculties to his 88th year, when he gradually ceased to breathe, and, as it were, fell asleep on March 3. 1780. He was interred in the south aisle of Canterbury cathedral, leaving one son, Anthony, educated in his own profession; and a daughter, Susanna, mentioned above.

His abilities as a painter appear in his works, which will not only be admired by his contemporaries, but by their posterity; as his tints, like those of Rubens and Vandyck, instead of being impaired, are improved by time, which some of them have now withstood above 60 years. His idea of beauty, when he indulged his fancy, was of the highest kind; and his knowledge of perspective gave him great advantages in family-pieces, of which he painted more than any one of his time. He could take a likeness by memory as well as by a sitting, as appears by his picture of the duke of Lorraine (the late emperor), which Faber engraved; and those of King George II. (in York assembly-room), Queen Caroline, the two Miss Gonnings, &c. Like many other great painters, he had "a poet for his friend," in the late Mr Browne; to which may be added a poem addressed to him in 1726, by the reverend Mr Bunce, at that time of Trinity-hall, Cambridge, who succeeded Mr Highmore, and in 1780 was vicar of St Stephen's near Canterbury.

HIGHNESS, a quality or title of honour given to princes.—The kings of England and Spain had formerly no other title but that of *highness*; the first till the time of James I. and the second till that of Charles V. The petty princes of Italy began first to be complimented with the title of *highness* in the year 1630.—The duke of Orleans assumed the title of *royal highness* in the year 1631, to distinguish himself from the other princes of France.

The duke of Savoy, afterwards king of Sardinia, bore the title of *royal highness*, on account of his pretensions to the kingdom of Cyprus.—It is said that duke only took the title of *royal highness*, to put him-

self above the duke of Florence, who was called *great duke*; but the great duke afterwards assumed the title of *royal highness*, to put himself on a level with the duke of Savoy.

The prince of Condé first took the title of *most serene highness*, leaving that of simple *highness* to the natural princes.

HILARIA, in antiquity, feasts celebrated every year by the Romans on the 8th of the kalends of April, or the 25th of March, in honour of Cybele the mother of the gods.

The hilaria were solemnized with great pomp and rejoicing. Every person dressed himself as he pleased, and took the marks or badges of whatever dignity or quality he had a fancy for. The statue of the goddess was carried in procession through the streets of the city, accompanied by multitudes in the most splendid attire. The day before the festival was spent in tears and mourning. Cybele represented the earth, which at this time of the year begins to feel the kindly warmth of the spring; so that this sudden transition from sorrow to joy was an emblem of the vicissitude of the seasons, which succeed one another.

The Romans took this feast originally from the Greeks, who called it *ἀναβασις*, q. d. *ascensus*; the eve of that day they spent in tears and lamentations, and thence denominated it *καταβασις*, *descensus*.

Afterwards, the Greeks took the name *ἡμέρα* from the Romans; as appears from Photius, in his extract of the life of the philosopher Isidore.

Casabon maintains, that beside this particular signification, the word hilaria was also a general name for any joyful or festival day, whether public or private and domestic. But Salmassius does not allow of this.

Tristan, tom. i. p. 482. distinguishes between hilaria and hilaris. The former, according to him, were public rejoicings; and the latter, prayers made in consequence thereof; or even of any private feast or rejoicing, as a marriage, &c. The public lasted several days; during which, all mourning and funeral ceremonies were suspended.

HILARIUS, an ancient father of the Christian church, who flourished in the 4th century. He was born, as St Jerome informs us, at Poitiers, of a good family; who gave him a liberal education in the Pagan religion, and which he did forsake till he was arrived at maturity. He was advanced to the bishopric of Poitiers in the year 355, according to Baronius: and became a most zealous champion for the orthodox faith, particularly against the Arians, who were at that time gaining ground in France. He assembled several councils there, in which the determinations of the synods of Rimini and Seleucia were condemned. He wrote a treatise concerning synods; and a famous work in 12 books on the Trinity, which is much admired by the orthodox believers. He died in the latter end of the year 367. His works have been many times published; but the last and best edition of them was given by the Benedictines at Paris in 1693.

HILARODI, in the ancient music and poetry, a sort of poets among the Greeks, who went about singing little gay poems or songs, somewhat graver than the Ionic pieces, accompanied with some instrument. From the streets they were at last introduced into tragedy,

Highness
Hilarodi.

tragedy, as the magodi were into comedy. They appeared dressed in white, and were crowned with gold. At first they wore shoes; but afterwards they assumed the crepida, being only a sole tied over with a strap.

HILARY-TERM. See **TERM.**

HILDESHEIM, a small district of Germany, in the circle of Lower Saxony. It lies between the duchies of Lauenburg and Brunswick; and may be about 25 miles from east to west, and 36 from north to south. It is watered by the rivers Leine and Inneraty. The soil is fertile; and its principal places are Peine, Sarsted, Bruggen, and Alvoid. Hildesheim, from whence it takes its name, was formerly an imperial city. It is now subject to Hanover.

HILDESHEIM, a strong city of Germany, in Lower Saxony, with a Roman Catholic bishop's see. It was a free imperial city, though in some things dependent on the bishop, but is now stript of its privileges. It is a large town, well built and fortified. It is divided into the Old Town and the New, which have each their separate council. It is seated on the river Ernest, in E. Long. 10. 0. N. Lat. 52. 17.

HILL, a term denoting any considerable eminence on the earth's surface. It is sometimes synonymous with the word *mountain*; though generally it denotes only the lesser eminences, the word *mountain* being particularly applied to the very largest. See **MOUNTAIN**, **GEOLOGY** *Indes.*

HILL, *Aaron*, a poet of considerable eminence, the son of a gentleman of Malmesbury-abbey in Wiltshire, was born in 1685. His father's imprudence having cut off his paternal inheritance, he left Westminster school at 14 years of age; and embarked for Constantinople, to visit Lord Paget the English ambassador there, who was his distant relation. Lord Paget received him with surprise and pleasure, provided him a tutor, and sent him to travel: by which opportunity he saw Egypt, Palestine, and a great part of the east; and returning home with his noble patron, visited most of the courts of Europe. About the year 1709, he published his first poem entitled *Camillus*, in honour of the earl of Peterborough who had been general in Spain; and being the same year made master of Drury-lane theatre, he wrote his first tragedy *Elfred*, or the *Fair Inconstant*. In 1710, he became master of the opera-house in the Hay-market; when he wrote an opera called *Rinaldo*, which met with great success, being the first that Mr Handel set to music after he came to England. Unfortunately for Mr Hill, he was a projector as well as poet, and in 1715 obtained a patent for extracting oil from beech-nuts; which undertaking, whether good or bad, miscarried after engaging three years of his attention. He was also concerned in the first attempt to settle the colony of Georgia; from which he never reaped any advantage; and in 1728 he made a journey into the Highlands of Scotland, on a scheme of applying the woods there to ship-building; in which he also lost his labour. Mr Hill seems to have lived in perfect harmony with all the writers of his time, except Mr Pope, with whom he had a short paper-war, occasioned by that gentleman's introducing him in the *Dunciad*, as one of the competitors for the prize offered by the goddess of Dulness, in the following lines:

"Then *Hill* essay'd; scarce vanished out of sight,
"He buoys up instant, and returns to light;
"He bears no token of the sabler streams,
"And mounts far off among the Swans of Thames'."

Hill

This, though far the gentlest piece of satire in the whole poem, and conveying at the same time an oblique compliment, roused Mr Hill to take some notice of it; which he did by a poem written during his peregrination in the north, entitled, "The Progress of Wit, a Caveat for the use of an eminent writer;" which he begins with the following eight lines, in which Mr Pope's too well known disposition is elegantly, yet very severely characterized:

"Tuneful *Alexis* on the Thames' fair side,
"The Ladies play-thing, and the Muses pride;
"With merit popular, with wit polite,
"Easy tho' vain, and elegant tho' light;
"Desiring and deserving others praise,
"Poorly accepts a Fame he ne'er repays:
"Unborn to cherish, sneakingly approves;
"And wants the soul to spread the worth he loves."

The *sneakingly approves*, in the last couplet, Mr Pope was much affected by; and indeed through their whole controversy afterwards, in which it was generally thought that Mr Hill had much the advantage, Mr Pope seems rather to express his repentance by denying the offence, than to vindicate himself supposing it to have been given. Besides the above poems, Mr Hill, among many others, wrote one, called *The northern star*, upon the actions of Czar Peter the Great; for which he was several years afterwards complimented with a gold medal from the empress Catharine, according to the Czar's desire before his death. He likewise altered some of Shakespeare's plays, and translated some of Voltaire's. His last production was *Merope*; which was brought upon the stage in Drury-lane by Mr Garrick. He died on the 8th of February 1749, as it is said, in the very minute of the earthquake; and after his decease four volumes of his works in prose and verse were published in octavo, and his dramatic works in two volumes.

HILL, *Sir John*, a voluminous writer, was originally bred an apothecary; but his marrying early, and without a fortune, made him very soon look around for other resources than his profession. Having, therefore, in his apprenticeship, attended the botanical lectures of the company, and being possessed of quick natural parts, he soon made himself acquainted with the theoretical as well as practical parts of botany: from whence being recommended to the late duke of Richmond and Lord Petre, he was by them employed in the inspection and arrangement of their botanic gardens. Assisted by the liberality of these noblemen, he executed a scheme of travelling over the kingdom, to collect the most rare and uncommon plants; which he afterward published by subscription: but after great researches and uncommon industry, this undertaking turned out by no means adequate to his expectation. The stage next presented itself, as a soil in which genius might stand a chance of flourishing: but after two or three unsuccessful attempts, it was found he had no pretensions either to the sock or buskin: which once more reduced him to his botanical pursuits, and his

Hil.
Hillel.

business as an apothecary. At length, about the year 1746, he translated from the Greek, a small tract written by Theophrastus, on Gems, which he published by subscription; and which, being well executed, procured him friends, reputation, and money. Encouraged by this, he engaged in works of greater extent and importance. The first he undertook was a General Natural History, in 3 vols. folio. He next engaged, in conjunction with George Lewis Scott, Esq. in furnishing a Supplement to Chambers's Dictionary. He at the same time started the British Magazine; and while he was engaged in a great number of these and other works, some of which seemed to claim the continued attention of a whole life, he carried on a daily essay, under the title of Inspector. Amidst this hurry of business, Mr Hill was so laborious and ready in all his undertakings, and was withal so exact an economist of his time, that he scarcely ever missed a public amusement for many years: where, while he relaxed from the severer pursuits of study, he gleaned up articles of information for his periodical works. It would not be easy to trace Mr Hill, now Dr Hill (for he procured a diploma from the college of St Andrew's), through all his various pursuits in life. A quarrel he had with the Royal Society, for being refused as a member, which provoked him to ridicule that learned body, in A Review of the Works of the Royal Society of London, 4to, 1751; together with his over-writing himself upon all subjects without reserve; made him sink in the estimation of the public nearly in the same pace as he had ascended. He found as usual, however, resources in his own invention. He applied himself to the preparation of certain simple medicines: such as the essence of water-dock, tincture of valerian, balsam of honey, &c. The well-known simplicity of these medicines made the public judge favourably of their effects, insomuch that they had a rapid sale, and once more enabled the doctor to figure in that style of life ever so congenial to his inclination. Soon after the publication of the first of these medicines, he obtained the patronage of the earl of Bute, through whose interest he acquired the management of the royal gardens at Kew, with an handsome salary: and to wind up the whole of an extraordinary life, having, a little before his death, seized an opportunity to introduce himself to the knowledge of the king of Sweden, that monarch invested him with one of the orders of his court, which title he had not the happiness of enjoying above two years. He died toward the close of the year 1775.

HILLEL, senior, of Babylon, president of the sanhedrim of Jerusalem. He formed a celebrated school there, in which he maintained the oral traditions of the Jews against Shamai, his colleague, whose disciples adhered only to the written law; and this controversy gave rise to the sects of Pharisees and Scribes. He was likewise one of the compilers of the Talmud. He also laboured much at giving a correct edition of the sacred text; and there is attributed to him an ancient manuscript bible, which bears his name. He flourished about 30 years B. C. and died in a very advanced age.

HILLEL, the nasi, or prince, another learned Jew, the grandson of Judas Hakkodesh, or the Saint, the author of the Mishna, lived in the fourth century. He composed a cycle; and was one of the principal doc-

tors of the Gamara. The greatest number of the Jewish writers attribute to him the correct edition of the Hebrew text which bears the name of *Hillel*, which we have already mentioned in the preceding article. There have been several other Jewish writers of the same name.

HILLIA, a genus of plants belonging to the hexandria class; and in the natural method ranking with those of which the order is doubtful. See BOTANY *Index*.

HILLSBOROUGH, a borough, fair, and post-town, in the county of Down, and province of Ulster, 60 miles from Dublin. Here is a fine seat of the earl of Hillsborough. The town is pleasantly situated and almost new built, in view of Lisburn, Belfast, and Carrickfergus bay; the church is magnificent, having an elegant spire, as lofty as that of St Patrick's in Dublin, and seven painted windows. This place gives title of earl to the family of Hillsborough. N. Lat. 54. 30. W. Long. 5. 56.

HILUM, among botanists, denotes the eye of a bean.

HIMALEH, a very high chain of mountains in Asia. See SUPPLEMENT.

HIMERA, in *Ancient Geography*, the name of two rivers in Sicily; one running northwards into the Tuscan sea, now called *Fiume de Termini*: and the other southwards into the Libyan; dividing Sicily into two parts, being the boundary between the Syracusans to the east and Carthaginians to the west; not rising from the same, but from different springs.

HIMERA, in *Ancient Geography*, a town of Sicily, at the mouth of the Himera, which ran northwards, on its left or west side: A colony of Zancle: afterwards destroyed by the Carthaginians (Diodorus Siculus).

HIMERENSES THERMÆ, in *Ancient Geography*, a town of Sicily, on the east side of that Himera which runs to the north. After the destruction of the town of Himera by the Carthaginians, such of the inhabitants as remained, settled in the same territory, not far from the ancient town. Now Termini. Made a Roman colony by Augustus.

HIN, a Hebrew measure of capacity for things liquid, containing the sixth part of an ephah, or one gallon two pints English measure.

HINCKLEY, a market-town of Leicestershire, built on a rising ground, nearly on the borders of Leicestershire, from which it is separated by the Roman Watling-street road. It is distant from Coventry and Leicester 15 miles each, and 102 from London. It has been much larger than it is at present, the back lanes between the orchards having evidently been streets originally, and the traces of the town-wall and ditch are in many places yet visible. There are vestiges of two Roman works, viz. the mount near the river, and the ruins of a bath near St Nicholas church, where tessellated pavements have been dug up. The Jewry wall is said to have been the temple of Janus. The castle was inhabited by John of Gaunt; but is now no more, the scite being converted into garden-ground, the castle-hill considerably lowered, and a gentleman's house erected on the spot in 1770. The steeple of the present church was built with some of the stones of the castle. The town is now divided into the borough, and

Hillel
Hinsley.

and the bond without the liberties. It has a good market on Mondays, and a fair in August. The chief manufacture is stockings and fine ale. The town contained 6058 inhabitants in 1811. There are two churches, one chapel, and a place of worship for the Roman Catholics, besides four meeting-houses. The church is a neat large old structure with a modern tower and a spire, the body of it was built in the 13th century, and near it are three mineral springs. This town is said to be the middle and highest ground in England; and from it 50 churches may be seen, besides gentlemen's seats. It received great damage by a fire September 5. 1728.

HIND, a female stag in the third year of its age. See CERVUS, MAMMALIA *Indes*.

HINDON, a small town of Wiltshire in England, which sends two members to parliament. It is situated in E. Long. 2. 14. N. Lat. 51. 12.

HINDOOS, or GENTOOS, the inhabitants of that part of India known by the name of *Hindustan* or the *Mogul's empire*, who profess the religion of the Bramins, supposed to be the same with that of the ancient Gymnosophists of Ethiopia.

From the earliest period of history these people seem to have maintained the same religion, laws, and customs, which they do at this day: and indeed they and the Chinese are examples of perseverance in these respects altogether unknown in the western world. In the time of Diodorus Siculus they are said to have been divided into seven casts or tribes: but the intercourse betwixt Europe and India was in his time so small, that we may well suppose the historian to have been mistaken, and that the same tenacity for which they are so remarkable in other respects has manifested itself also in this. At present they are divided only into four tribes; 1. The Bramin; 2. The Khatry; 3. The Bhyse; and, 4. The Soodera. All these have distinct and separate offices, and cannot, according to their laws, intermingle with each other; but for certain offences they are subject to the loss of their cast, which is reckoned the highest punishment they can suffer; and hence is formed a kind of fifth cast named *Pariars* on the coast of Coromandel, but in the Sanscrit or sacred language *Chandalas*. These are esteemed the dogs of the people, and are never employed but in the meanest offices. There is besides a general division which pervades the four casts indiscriminately, and which is taken from the worship of their gods *Vishnou* and *Sheevah*; the worshippers of the former being named *Vishnou-bukht*; of the latter *Sheevah-bukht*.

Of these four casts the Bramins are accounted the foremost in every respect; and all the laws have such an evident partiality towards them, as cannot but induce us to suppose that they have had the principal hand in framing them. They are not, however, allowed to assume the sovereignty; the religious ceremonies and the instruction of the people being their peculiar province. They alone are allowed to read the *Veda* or sacred books; the *Khatrics*, or cast next in dignity, being only allowed to hear them read; while the other two can only read the *Sastras* or commentaries upon them. As for the poor *Chandalas*, they dare not enter a temple, or be present at any religious ceremony.

In point of precedency the Bramins claim a superiority even to the princes; the latter being chosen out of the Khatry or second cast. A rajah will receive with respect the food that is prepared by a Bramin, but the latter will eat nothing that has been prepared by any member of an inferior cast. The punishment of a Bramin for any crime is much milder than if he had belonged to another tribe; and the greatest crime that can be committed is the murder of a Bramin. No magistrate must *desire* the death of one of these sacred persons, or cut off one of their limbs. They must be readily admitted into the presence even of princes whenever they please: when passengers in a boat, they must be the first to enter and to go out; and the waterman must besides carry them for nothing; every one who meets them on the road being likewise obliged to give place to them.

All the priests are chosen from among this order, such as are not admitted to the sacerdotal function being employed as secretaries and accountants. These can never afterwards become priests, but continue to be greatly revered by the other casts.

The Khatry or second cast are those from among whom the sovereigns are chosen.—The Bhyse or Banians, who constitute the third cast, have the charge of commercial affairs; and the Soodera, or fourth cast, the most numerous of all, comprehend the labourers and artisans. These last are divided into as many classes as there are followers of different arts; all the children being invariably brought up to the profession of their fathers, and it being absolutely unlawful for them ever to alter it afterwards.

No Hindoo is allowed to quit the cast in which he was born upon any account. All of them are very scrupulous with regard to their diet; but the Bramins much more so than any of the rest. They eat no flesh, nor shed blood; which we are informed by Porphyry and Clemens Alexandrinus was the case in their time. Their ordinary food is rice and other vegetables, dressed with *ghce* (a kind of butter melted and refined so as to be capable of being kept for a long time), and seasoned with ginger and other spices. The food which they most esteem, however, is milk, as coming from the cow; an animal for which they have the most extravagant veneration, insomuch that it is enacted in the code of Gentoos laws, that any one who exacts labour from a bullock that is hungry or thirsty, or that shall oblige him to labour when fatigued or out of season, is liable to be fined by the magistrates. The other casts, though less rigid, abstain very religiously from what is forbidden them; nor will they eat any thing provided by a person of an inferior cast, or by one of a different religion. Though they may eat some kinds of flesh and fish, yet it is counted a virtue to abstain from them all. None of them are allowed to taste intoxicating liquor of any kind. Quintus Curtius indeed mentions a sort of wine made use of by the Indians in his time; but this is supposed to have been no other than toddy, or the unfermented juice of the cocoa nut. This when fermented affords a spirit of a very unwholesome quality; but it is drunk only by the *Chandalas* and the lower class of Europeans in the country. So exceedingly bigotted and superstitious are they in their absurd maxims with regard to meat and drink, that some seapoys in a British ship having

expended

Hindoo. expended all the water appropriated to their use, would have suffered themselves to perish for thirst rather than taste a drop of that which was used by the ship's company.

Of the religion of the Hindoos.

The religion of the Hindoos, by which these maxims are inculcated, and by which they are made to differ so much from other nations, is contained in certain books named *Veda*, *Vedams*, or *Beds*, written in a language called *Shanscrit*, which is now known only to the learned among them. The books are supposed to have been the work not of the supreme God himself, but of an inferior deity named *Brimha*. They inform us, that Brama, or Brahma, the supreme God, having created the world by the word of his mouth, formed a female deity named *Bawaney*, who in the enthusiasm of joy and praise brought forth three eggs. From these were produced three male deities, named *Brimha*, *Vishnou*, and *Sheevah*. *Brimha* was endowed with the power of creating the things of this world, *Vishnou* with that of cherishing them, and *Sheevah* with that of restraining and correcting them. Thus *Brimha* became the creator of man; and in this character he formed the four casts from different parts of his own body, the Bramins from his mouth, the Khatry from his arms, the Banians from his belly and thighs, and the Soedera from his feet. Hence, say they, these four different casts derive the different offices assigned them; the Brahmins to teach; the Khatry to defend and govern; the Banians to enrich by commerce and agriculture; and the Soedera to labour, serve, and obey. Brama himself endowed mankind with passions, and understanding to regulate them; while *Brimha*, having created the inferior beings, proceeded to write the *Vedams*, and delivered them to be read and explained by the Bramins.

The religion of the Hindoos, though involved in superstition and idolatry, seems to be originally pure; inculcating the belief of an eternal and omnipotent Being; their subordinate deities *Brimha*, *Vishnou*, and *Sheevah*, being only representatives of the wisdom, goodness, and power, of the supreme God Brama. All created things they suppose to be *types* of the attributes of Brama, whom they call the *principle of truth*, the *spirit of wisdom*, and the *supreme being*; so that it is probable that all their idols were at first only designed to represent these attributes.

Different sects.

There are a variety of sects among the Hindoos: two great classes we have mentioned already, viz. the worshippers of *Vishnou*, and those of *Sheevah*; and these distinguish themselves, the former by painting their faces with an horizontal line, the latter by a perpendicular one. There is, however, very little difference in point of religion between these or any other Hindoo sects. All of them believe in the immortality of the soul, a state of future rewards and punishments, and transmigration. Charity and hospitality are inculcated in the strongest manner, and exist among them not only in theory but in practice. "Hospitality (say they) is commanded to be exercised even towards an enemy, when he cometh into thine house; the tree doth not withdraw its shade even from the wood-cutter. Good men extend their charity even to the vilest animals. The moon doth not withhold her light even from the Chandala." These pure doctrines, however, are intermixed with some of the vilest and most absurd

superstitions; and along with the true God they worship a number of inferior ones, of whom the principal are:

Hindoo.

1. *Bawaney*, the mother of the gods, already mentioned, and superior to all but Brama himself; but all the other goddesses are reckoned inferior to their gods or lords.

2. *Brimha*, in the Shanscrit language said to mean "the wisdom of God;" and who is supposed to fly on the wings of the *hanse* or flamingo; an image of which is constantly kept near that of the god in the temple where he is worshipped. He has a crown on his head, and is represented with four hands. In one of these he holds a sceptre, in another the sacred books or *Vedams*, in the third a ring or circle as the emblem of eternity, supposed to be employed in assisting and protecting his works.

4
Account of their principal deities.

3. *Seraswatej*, the goddess or wife of *Brimha*, presides over music, harmony, eloquence, and invention. She is also said to be the inventress of the letters called *Devanagry*, by which the divine will was first promulgated among mankind. In the argument of an hymn addressed to this goddess, she is supposed to have a number of inferior deities acting in subordination to her. These are called *Rags*, and preside over each mode, and likewise over each of the seasons. These seasons in Hindostan are six in number; viz. 1. The *Soessar*, or dewy season. 2. *Heemat*, or the cold season. 3. *Vasant*, the mild season or spring. 4. *Greshma*, or the hot season. 5. *Varoa*, the rainy season. 6. *Sarat*, the breaking up or end of the rains.

The *Rags*, in their musical capacity, are accompanied each with five *Ragnies*, a kind of female deities or nymphs of harmony. Each of these has eight sons or genii; and a distinct season is appointed for the music of each rag, during which only it can be sung or played; and this at distinct or stated hours of the day or night. A seventh mode of music belonging to *Deipec*, or *Cupid the inflamer*, is said once to have existed, but now to be lost; and a musician, who attempted to restore it, to have been consumed with fire from heaven.

4. *Vishnou*, the most celebrated of all the Indian deities, is supposed to fly or ride on the garroora, a kind of large brown kite, which is found in plenty in the neighbourhood; and on which *Vishnou* is sometimes represented as sitting; though at others he is represented on a serpent with a great number of different heads. At some of his temples the Bramins accustom all the birds they can find, of the species above mentioned, to come and be fed; calling them by striking upon a brass plate. This deity is said to have had ten different incarnations to destroy the giants with which the earth was infested; and in these he is represented in as many different figures, all of which are to the last degree fantastic and monstrous. His common form is that of a man with four hands, and a number of heads set round in a circle, supposed to be emblems of omniscience and omnipotence. In his first incarnation he is represented as coming out of the mouth of a fish, with several hands containing swords, &c. In another he has the head of a boar with monstrous tusks, bearing a city in the air, and stands upon a vanquished giant with horns on his head. In others of his incarnations, he has the head of a horse or other animals,

Doc. animals, with a great number of arms brandishing swords, &c.

In some parts of his character this deity is represented not as a destroyer, but a preserver of mankind; and he is then distinguished by the name of *Harj*. Bishop Wilkins describes an image of him in this character at a place named *Jehan-query*, a small rocky island of the Ganges in the province of Bahar. This image is of a gigantic size, recumbent on a coiled serpent, whose numerous heads are twisted by the artist into a kind of canopy over the sleeping god, and from each of its mouths issues a forked tongue, as threatening destruction to those who should dare to approach.

5. *Sheevah* is represented under a human form, though frequently varied, as is also his name; but he is most frequently called *Sheevah* and *Muhadeg*. In his destroying character he is represented as a man with a fierce look, and with a snake twisted round his neck. He is thought to preside over good and evil fortune, in token of which he is represented with a crescent on his head. He rides upon an ox.

6. *Vikrama*, the god of victory, is said to have had a particular kind of sacrifice offered to him, somewhat like the scape-goat of the Jews, viz. by letting a horse loose in the forest, and not employing him again.

7. *Yam Rajah*, or *Darham Rajah*, is represented as the judge of the dead, and ruler of the infernal regions, in a manner similar to the Minos and Pluto of the ancient Greeks. He is the son of *Sour*, "the sun," by *Bisookama* daughter of the great architect of the heavenly mansions, and patron of artificers. He rides upon a buffalo, with a sceptre in his hand, having two assistants, *Chiter* and *Gopt*; the former of whom reports the good, and the latter the bad actions of men. These are attended by two genii, who watch every individual of the human race; *Chiter's* spy being on the right, and *Gopt's* on the left. The souls of deceased persons are carried by the *Jambouts* or messengers of death into the presence of *Darham*, where their actions are instantly proclaimed, and sentence passed accordingly. The infernal mansions are named by the Hindoos *Narekha*, and are divided into a great number of places, according to the degrees of punishment to be endured by the criminal; but eternal punishment for any offence is supposed to be inconsistent with the goodness of God. Instead of this, the Hindoos suppose that after the souls of the wicked have been punished long enough in *Narekha*, they are sent back into the world to animate other bodies either of men or beasts, according to circumstances. Those who have lived a life partly good and partly bad, are likewise sent back to this world; and these trials and transmigrations are repeated till they be thoroughly purged of all in inclination to sin. But as for those holy men who have spent their lives in piety and devotion, they are instantly conveyed by the genii to the mansions of celestial bliss, where they are absorbed into the universal spirit; a state, according to every idea we can form, equivalent to annihilation!

8. *Krishen* and the nine *Gopia*, among the Hindoos, correspond with Apollo and the nine muses of the Greeks. This deity is represented as a young man sometimes playing on a flute. He has a variety of names, and is supposed to be of a very amorous complexion, having once resided in a district named *Birge*,

where he embraced almost all the women in the country. From his residence here, or from these amorous exploits, he is sometimes called *Birge-put*.

9. *Kama-deva*, the god of love, is said to be the son of *Maya*, or the general attractive power; married to *Retty*, or *Affection*. He is represented as a beautiful youth, sometimes conversing with his mother or consort in his temples or gardens; at other times riding on a parrot by moonlight: And Mr Forster informs us, that on the taking of Tanjore by the English, a curious picture was found, representing him riding on an elephant, the body of which was composed of seven young women twisted together in such a manner as to represent that enormous animal. This is supposed to be a device of a similar nature with that of the Greeks, who placed their *Eros* upon a lion; thus intimating, that love is capable of taming the fiercest of animals. The bow of this deity is said to be of sugar-cane, or of *flowers*, and the string of *bees*: he has five arrows, each of them tipped with an Indian blossom of an heating nature. His ensign is a fish on a red ground, carried by the foremost of his attendant nymphs or dancing girls.

10. *Lingam*, corresponding to the Priapus or Phallus of the ancients, is worshipped by the Hindoos in order to obtain fecundity. This deity is adored the more fervently, as they depend on their children for performing certain ceremonies to their manes, which they imagine will mitigate their punishment in the next world. The devotees of the god go naked, but are supposed to be such sanctified persons, that women may approach them without any danger. They vow perpetual chastity; and death is the consequence of a breach of their vow. Husbands whose wives are barren invite them to their houses, where certain ceremonies, generally thought to be effectual, are performed.

Besides these, there is a number of other gods whose character is less eminent; though it seems not to be ascertained distinctly, even by the Hindoos themselves, what particular rank each deity holds with respect to another. Some of these deities are, 11. *Nared*, the son of *Brimha*, and inventor of a fretted instrument named *Vene*. 12. *Lechmy*, the goddess of plenty, and wife of *Vishnou*. 13. *Gowry*, *Katy*, from *Kala*, "time;" the wife of *Sheevah*, and goddess of destruction. 14. *Varoona*, the god of the seas and waters, riding on a crocodile. 15. *Vayoo*, the god of the winds, riding on an antelope with a sabre in his hand. 16. *Agnee*, the god of fire, riding on a ram. 17. *Vasoodka*, a goddess representing the earth. 18. *Pakreety*, or nature, represented by a beautiful young woman. 19. *Sour* or *Shan*, the sun; called also the king of the stars and planets, represented as sitting in a chariot drawn by one horse, sometimes with seven and sometimes with twelve heads. 20. *Sangia*, the mother of the river *Jumna*, and wife of the sun. 21. *Chandava*, the moon, in a chariot drawn by antelopes, and holding a rabbit in her right hand. 22. *Vreekaspaty*, the god of learning, attended by beautiful young nymphs, named *Veedyadhare*, or professors of science. 23. *Ganes*, the god of prudence and policy, worshipped before the undertaking of any thing of consequence. 24. *Fame*, represented by a serpent with a great number of tongues; and known by several

Hindoos. names. 25. *Darma-deva*, the god of virtue, sometimes represented by a white bull. 26. *Virsavana* or *Cobhair*, the god of riches, represented by a man riding on a white horse. 27. *Dhan-wuntary*, the god of medicine.

5
Their demigods.

Besides the supreme deities the Hindoos have a number of demigods, who are supposed to inhabit the air, the earth, and the waters, and in short the whole world; so that every mountain, river, wood, town, village, &c. has one of these tutelar deities, as was the case among the western heathens. By nature these demigods are subject to death, but are supposed to obtain immortality by the use of a certain drink named *Amrut*. Their exploits in many instances resemble those of Bacchus, Hercules, Theseus, &c. and in a beautiful epic poem named *Rancyan*, we have an account of the wars of Ram, one of the demigods, with Ravana tyrant of Ceylon.

6
Manner of worship.

All these deities are worshipped, as in other countries, by going to their temples, fasting, prayers, and the performance of ceremonies to their honour. They pray thrice a day, at morning, noon, and evening, turning their faces towards the east. They use many ablutions, and, like the Pharisees of old, they always wash before meals. Running water is always preferred for this purpose to such as stagnates. Fruits, flowers, incense, and money, are offered in sacrifice to their idols; but for the dead they offer a kind of cake named *Peenda*; and offerings of this kind always take place on the day of the full moon. Nothing sanguinary is known in the worship of the Hindoos at present, though there is a tradition that it was formerly of this kind; nay, that even human sacrifices were made use of: but if such a custom ever did exist, it must have been at a very distant period. Their sacred writings indeed make mention of bloody sacrifices of various kinds, not excepting even those of the human race: but so many peculiarities are mentioned with regard to the proper victims, that it is almost impossible to find them. The only instance of bloody sacrifices we find on record among the Hindoos is that of the buffalo to Bawaney, the mother of the gods.

Among the Hindoos there are two kinds of worship, distinguished by the name of the worship of the *invisible God* and of *idols*. The worshippers of the invisible God are, strictly speaking, deists: the idolaters perform many absurd and unmeaning ceremonies, too tedious to mention, all of which are conducted by a bramin; and during the performance of these rites, the dancing women occasionally perform in the court, singing the praises of the deity in concert with various instruments. All the Hindoos seem to worship the fire; at least they certainly pay a great veneration to it. Bishop Wilkins informs us, that they are enjoined to light up a fire at certain times, which must be produced by the friction of two pieces of wood of a particular kind; and the fire thus produced is made use of for consuming their sacrifices, burning the dead, and in the ceremonies of marriage.

7
Their devotes.

Great numbers of devotees are to be met with every where through Hindostan. Every cast is allowed to assume this way of life excepting the Chandalabs, who are excluded. Those held most in esteem are named *Sentussess* and *Jogeys*. The former are allowed no other

clothing but what suffices for covering their nakedness, nor have they any worldly goods besides a pitcher and staff; but though they are strictly enjoined to meditate on the truths contained in the sacred writings, they are expressly forbidden to argue about them. They must eat but once a day, and that very sparingly, of rice or other vegetables; they must also show the most perfect indifference about hunger, thirst, heat, cold, or any thing whatever relative to this world; looking forward with continual desire to the separation of the soul from the body. Should any of them fail in this extravagant self-denial, he is rendered so much more criminal by the attempt, as he neglected the duties of ordinary life for those of another which he was not able to accomplish. The *Jogeys* are bound to much the same rules, and both subject themselves to the most extravagant penances. Some will keep their arms constantly stretched over their heads till they become quite withered and incapable of motion; others keep them crossed over their breast during life; while others, by keeping their hands constantly shut, have them quite pierced through by the growth of their nails. Some chain themselves to trees or particular spots of ground, which they never quit; others resolve never to lie down, but sleep leaning against a tree: but the most curious penance perhaps on record is that of a *Jogey*, who measured the distance between Benares and Jaggernaut with the length of his body, lying down and rising alternately. Many of these enthusiasts will throw themselves in the way of the chariots of Vishnou or Sheevah, which are sometimes brought forth in procession to celebrate the feast of a temple and drawn by several hundreds of men. Thus the wretched devotees are in an instant crushed to pieces. Others devote themselves to the flames, in order to show their regard to some of their idols, or to appease the wrath of one whom they suppose to be offended.

A certain set of devotees are named *Pandarams*; and another on the coast of Coromandel are named *Cary-Patra Pandarams*. The former rub themselves all over with cow-dung, running about the country singing the praises of the god Sheevah whom they worship. The latter go about asking charity at doors by striking their hands together, for they never speak. They accept of nothing but rice; and when they have got as much as will satisfy their hunger, never give themselves any trouble about more, but pass the rest of the day in the shade, in a state of such supine indolence as scarcely to look at any object whatever. The *Tadinams* are another set of mendicants, who sing the incarnations of Vishnou. They have hollow brass rings round their ancles, which they fill with pebbles; so that they make a considerable noise as they walk; they beat likewise a kind of tabor.

The greatest singularity in the Hindoo religion ⁸ however, is, that so far from persecuting those of a ^{Mildness of} the Hindoo contrary persuasion, which is too often the case with religion. other professors, they absolutely refuse even to admit of a proselyte. They believe all religions to be equally acceptable to the Supreme Being; assigning as a reason, that if the Author of the universe preferred one to another, it would have been impossible for any other to have prevailed than that which he approved. Every religion,

⁹ **Hindoo.** religion, therefore, they conclude to be adapted to the country where it is established; and that all in their original purity are equally acceptable.

their mar- Among the Hindoos, marriage is considered as a religious duty; and parents are strictly commanded to marry their children by the time they arrive at eleven years of age at farthest. Polygamy is allowed; but this licence is seldom made use of unless there should be no children by the first wife. In case the second wife also proves barren, they commonly adopt a son from among their relations.

The Hindoos receive no dower with their wives; but, on the contrary, the intended husband makes a present to the father of his bride. Nevertheless, in many cases, a rich man will choose a poor relation for his daughter; in which case the bride's father is at the expence of the wedding, receives his son-in-law into his house, or gives him a part of his fortune. The bridegroom then quits the dwelling of his parents with certain ceremonies, and lives with his father-in-law. Many formalities take place between the parties even after the match is fully agreed upon; and the celebration of the marriage is attended with much expence; magnificent processions are made, the bride and bridegroom sitting in the same palankeen, attended by their friends and relations; some riding in palankeens, some on horses, and others on elephants. So great is their vanity indeed on this occasion, that they will borrow or hire numbers of these expensive animals to do honour to the ceremony. The rejoicings last several days; during the evenings of which, fire-works and illuminations are displayed, and dancing-women perform their feats; the whole concluding with alms to the poor, and presents to the bramins and principal guests, generally consisting of shawls, pieces of muslin, and other cloths. A number of other ceremonies are performed when the parties come of age, and are allowed to cohabit together. The same are repeated when the young wife becomes pregnant; when she passes the seventh month without any accident; and when she is delivered of her child. The relations assemble on the tenth day after the birth, to assist at the ceremony of naming the child; but if the bramins be of opinion that the aspect of the planets is at that time unfavourable, the ceremony is delayed, and prayers offered up to avert the misfortune. When the lucky moment is discovered, they fill as many pots with water as there are planets, and offer a sacrifice to them; afterwards they sprinkle the head of the child with water, and the bramin gives it such a name as he thinks best adapted to the time and circumstances; and the ceremony concludes with prayers, presents to the bramins, and alms to the poor. Mothers are obliged to suckle their own children; nor can this duty be dispensed with except in case of sickness. New ceremonies, with presents to the bramins, take place, when a boy comes of age to receive the string which the three first casts wear round their waist.

¹⁰ **location** Boys are taught to read and write by the bramins, **children.** who keep schools for that purpose throughout the country. They use leaves instead of books, and write with a pointed iron instrument. The leaves are generally chosen of the palm-tree, which being smooth and hard, and having a thick substance, may be kept for almost any length of time, and the letters are not subject to

grow faint or be effaced. The leaves are cut into slips about an inch broad, and their books consist of a number of these tied together by means of a hole in one end. Sometimes the letters are rubbed over with a black powder, to render them more legible. When they write upon paper, they make use of a small reed. Sometimes they are initiated in writing by making letters upon sand strewed on the floor; and they are taught arithmetic by means of a number of small pebbles. The education of the girls is much more limited; seldom extending farther than the articles of their religion.

¹¹ Among these people the custom of burning the dead **Barbarous** prevails universally; and the horrid practice of wives **custom of** burning themselves along with their deceased husbands **women** was formerly very common, though now much less so. **burning** At present it is totally prohibited in the British dominions; and even the Mohammedans endeavour to discountenance a practice so barbarous, though many of their governors are accused of conniving at it through motives of avarice. At present it is most common in the country of the Rajahs, and among women of high rank.

This piece of barbarity is not enjoined by any law existing among the Hindoos; it is only said to be *proper*, and rewards are promised in the next world to those who do so. But though a wife chooses to outlive her husband, she is in no case whatever permitted to marry again, even though the marriage with the former had never been completed. It is unlawful for a woman to burn herself if she be with child at the time of her husband's decease, or if he died at a distance from her. In the latter case, however, she may do so if she can procure his girdle or turban to be put on the funeral pile along with her. These miserable enthusiasts, who devote themselves to this dreadful death, suffer with the greatest constancy; and Mr Holwel gives an account of one who, being told of the pain she must suffer (with a view to dissuade her), put her finger into the fire and kept it there for a considerable time; after which she put fire on the palm of her hand, with incense upon it, and fumigated the bramins who were present. Sometimes a chapel is erected on the place where one of those sacrifices has been performed; sometimes it is inclosed, flowers planted upon it, and images set up.—In some few places the Hindoos bury their dead; and some women have been known to suffer themselves to be buried alive with their deceased husbands: but the instances of this are still more rare than those of burning.—No woman is allowed any inheritance among the Hindoos; so that if a man dies without male issue, his estate goes to his adopted son or to his nearest relation.

¹² The Hindoos, though naturally mild and timid, will **instances** on many occasions meet death with the most heroic **of heroism** intrepidity. An Hindoo who lies at the point of death, **among the** will talk of his decease with the utmost composure; **Hindoo.** and if near the river Ganges, will desire to be carried out, that he may expire on its banks. Such is the excessive veneration they have for their religion and customs, that no person will infringe them even to preserve his own life. An Hindoo, we are told, being ill of a putrid fever, was prevailed upon to send for an European physician, who prescribed him the bark in wine; but this was refused with the greatest obstinacy even

Hindoos. to the very last, though the governor himself joined in his solicitations, and in other matters had a considerable influence over him. In many instances these people, both in ancient and modern times, have been known, when closely besieged by an enemy whom they could not resist, to kill their wives and children, set fire to their houses, and then violently rush upon their adversaries till every one was destroyed. Some seapoys, in the British service, having been concerned in a mutiny, were condemned to be blown away from the mouths of cannon. Of these some were grenadiers, who cried out, that as they had all along had the post of honour, they saw no reason why they should be denied it now; and therefore desired that they might be blown away first. This being granted, they walked forward to the guns with composure, begged that they might be spared the indignity of being tied, and, placing their breasts close to the muzzles, were shot away. The commanding officer was so much affected with this instance of heroism, that he pardoned all the rest.

¹³ **Their general character.** In ordinary life the Hindoos are cheerful and lively; fond of conversation and amusements, particularly dancing. They do not, however, learn or practise dancing themselves, but have women taught for the purpose; and in beholding these they will spend whole nights. They disapprove of many parts of the education of European ladies, as supposing that they engage the attention too much, and draw away a woman's affection from her husband and children. Hence there are few women in Hindostan who can either read or write. In general they are finely shaped, gentle in their manners, and have soft and even musical voices. The women of Kashmere, according to Mr Forster, have a bright olive complexion, fine features, and delicate shape; a pleasing freedom in their manners, without any tendency to immodesty.

¹⁴ **Dress of the women.** The dress of the modest women in Hindostan consists of a close jacket, which covers their breasts, but perfectly shows their form. The sleeves are tight, and reach half way to the elbows, with a narrow border painted or embroidered all round the edges. Instead of a petticoat, they have a piece of white cotton cloth wrapped round the loins, and reaching near the ankle on the one side, but not quite so low on the other. A wide piece of muslin is thrown over the right shoulder; which, passing under the left arm, is crossed round the middle, and hangs down to the feet. The hair is usually rolled up into a knot or bunch towards the back part of the head; and some have curls hanging before and behind the ears. They wear bracelets on their arms, rings in their ears, and on their fingers, toes, and ankles; with sometimes a small one in their nostril.

The dress of the dancing women, who are likewise votaries of Venus, is very various. Sometimes they wear a jama, or long robe of wrought muslin, or gold and silver tissue; the hair plaited and hanging down behind, with spiral curls on each side of the face. They are taught every accomplishment which can be supposed to captivate the other sex; form a class entirely different from the rest of the people, and live by their own rules. Their clothes, jewels, and lodgings, are considered as implements of their trade, and must be allowed them in cases of confiscation for debt: They may drink spirituous liquors, and eat any kind of meat except

beef: Their dances are said to resemble pretty exactly those of the ancient Bacchanlians represented in some of the ancient paintings and bas reliefs. In some of their dances they attach gold and silver bells to the rings of the same metals they wear on their ankles. **Hindoos.**

The men generally shave their heads and beards, ¹⁵ leaving only a pair of small whiskers and a lock on the back part of their head, which they take great care to preserve. In Kashmere and some other places, they let their beards grow to the length of two inches. They wear turbans on their heads; but the Bramins who officiate in the temples commonly go with their heads uncovered, and the upper part of the body naked: round their shoulder they hang the sacred string called *Zennar*, made of a kind of perennial cotton, and composed of a certain number of threads of a determined length. The Kbatrics wear also a string of this kind, but composed of fewer threads; the Bhyse have one with still fewer threads, but the Sooderas are not allowed to wear any string. The other dress of the Bramins consists of a piece of white cotton cloth wrapped about the loins, descending below the knee, but lower on the left than on the right side. In cold weather they sometimes put a red cap on their heads, and wrap a shawl round their bodies.—The Kbatrics, and most other of the inhabitants of this country, wear also pieces of cotton cloth wrapped round them, but which cover the upper as well as the lower part of the body. Ear-rings and bracelets are worn by the men as well as women: and they are fond of ornamenting themselves with diamonds, rubies, and other precious stones, when they can procure them. They wear slippers on their feet of fine woollen cloth or velvet, frequently embroidered with gold and silver; those of princes being sometimes adorned with precious stones. The lower classes wear sandals or slippers of coarse woollen cloth, or leather. These slippers are always put off on going into any apartment, being left at the door, or given to an attendant; nevertheless the Hindoos make no complaints of the Europeans for not putting off their shoes when they come into their houses, which must certainly appear very uncouth to them.

Hindoo families are always governed by the eldest male, to whom great respect is shewn. Filial veneration is carried to such a height among them, that a son will not sit down in the presence of his father until ordered to do so: and Mr Forster observes, that during the whole time of his residence in India, he never saw a direct instance of undutifulness to parents; and the same is related by other writers.

The houses of the Hindoos make a worse appearance ¹⁶ than could be supposed from their ingenuity in other respects. In the southern parts of the country, the houses are only of one story. On each side of the door, towards the street, is a narrow gallery covered by the slope of the roof which projects over it, and which, as far as the gallery extends, is supported by pillars of brick or wood. The floor of this gallery is raised about 20 inches above the level of the street; and the porters, or bearers of palankeens, with the foot soldiers named *Peons*, who commonly hire themselves to noblemen, often lie down in this place. This entrance leads into a court, which is also surrounded by a gallery like the former. On one side of the court is a large room, on a level with the floor of the gallery; open in front, and

Hindoos.

spread with mats and carpets covered with white cotton cloth, where the master of the house receives visits and transacts business. From this court there are entrances by very small doors to the private apartments. In the northern parts, houses of two or three stories are commonly met with. Over all the country also we meet with the ruins of palaces, which evidently show the magnificence of former times.

came acquainted with the Indian astronomy in 1687, from a Siamese MS. containing rules for calculating the places of the sun and moon, brought home by M. Loubere the French ambassador at Siam. The principles on which the tables in this MS. were founded, however, proved to be so obscure, that it required the genius of Cassini to investigate them. The missionaries afterwards sent over two other sets of tables from Hindostan; but no attention was paid to them till M. le Gentil returned from observing the transit of Venus in 1769. During the time of his stay in Hindostan, the Bramins had been much more familiar with him on account of his astronomical knowledge, than they usually were with Europeans; and he thus had an opportunity of obtaining considerable insight into their methods of calculation. In consequence of this instruction he published tables and rules, according to the Indian method, in the academy of sciences for 1772; and in the explanation of these M. Bailly has employed a whole volume. The objects of this astronomy, according to Mr Playfair, are, 1. Tables and rules for calculating the places of the sun and moon. 2. Of the planets. 3. For determining the phases of eclipses. They divide the zodiac into 27 constellations, probably from the motion of the moon through it in 27 days; and to this lunar motion the Professor ascribes the general division of time into weeks, which has prevailed so universally throughout the world. The days of the week were dedicated to the planets, as by the ancient heathens of the west, and in precisely the same order. The ecliptic is divided into signs, degrees, and minutes, as with us: and indeed their calculations are entirely sexagesimal, the day and night being divided into 60 hours; so that each of their hours is only 24 of our minutes, and each of their minutes 24 of our seconds.

Edin. Phil. Trans.

17
Learning
of the Bra-
mins.

The Bramins of India were anciently much celebrated for their learning, though they now make a very inconsiderable figure in comparison with the Europeans. According to Philostratus, the Gymnosophists of Ethiopia, were a colony of Bramins, who being obliged to leave India on account of the murder of their king near the banks of the Ganges, migrated into that country. The ancient Bramins, however, may justly be supposed to have cultivated science with much greater success than their descendants can boast of, considering the ruinous wars and revolutions to which the country has been subjected. Metaphysics, as well as moral and natural philosophy, appear to have been well understood among them; but at present all the Hindoo knowledge is confined to those whom they call *Pundits*, "doctors or learned men." These only understand the language called *Shanscrit* or *Sanscrit*, (from two words signifying perfection); in which the ancient books were written.

18
Metaphy-
sica.

The metaphysics of the Bramins is much the same with that of some ancient Greek philosophers. They believe the human soul to be an emanation from the Deity, as light and heat from the sun. Gowtama, an ancient metaphysician, distinguishes two kinds of souls, the divine and vital. The former resembles the eternal spirit from which it came, is immaterial, indivisible, and without passions; the vital soul is a subtle element which pervades all things, distinct from organized matter, and which is the origin of all our desires. The external senses, according to this author, are representations of external things to the mind, by which it is furnished with materials for its various operations; but unless the mind act in conjunction with the senses, the operation is lost, as in that absence of mind which takes place in deep contemplation. He treats likewise of reason, memory, perception, and other abstract subjects. He is of opinion, that the world could not exist without a first cause; chance being nothing but the effect of an unknown cause: he is of opinion, however, that it is folly to make any conjectures concerning the beginning or duration of the world. In treating of providence, he denies any immediate interposition of the Deity; maintaining, that the Supreme Being having created the system of nature, allowed it to proceed according to the laws originally impressed upon it, and man to follow the impulse of his own desires, restrained and conducted by his reason. His doctrine concerning a future state is not different from what we have already stated as the belief of the Hindoos in general. According to Bishop Wilkins, many of them believe that this world is a state of rewards and punishments as well as of probation; and that good or bad fortune are the effects of good or evil actions committed in a former state.

19
Their a-
stronomy.

The science for which the Bramins, however, were most remarkable, is that of astronomy; and in this their progress was so great, as even yet to furnish matter of admiration to the moderns.—The Europeans first be-

The requisites for calculating by the Indian tables are, 1. An observation of the celestial body in some past moment of time, which is commonly called the Epoch of the tables. 2. The mean rate of the planet's motion. 3. The correction on account of the irregular motion of the body, to be added or subtracted from the mean place, according to circumstances. They calculate the places of the sun and moon, not from the time of their entrance into Aries, but into the moveable Zodiac. Thus the beginning of the year is continually advancing with regard to the seasons; and in 24,000 years will have made the complete round. The mean place of the sun for any time is deduced on the supposition that 800 years contain 292,207 days; from whence, by various calculations, the length of the year comes out only 1' 53" greater than that of De la Caille; which is more accurate than any of our ancient astronomical tables. In the equation of the sun's centre, however, they commit an error of no less than 16'. But Mr Playfair is of opinion that this cannot be ascribed wholly to their inaccuracy, as there was a time when their calculation approached very near the truth; and even at present the error is less than it appears to be.

The motions of the moon are deduced from a cycle of 19 years; during which she makes nearly 235 revolutions; and which period constitutes the famous cycle supposed to have been invented by Meton the Athenian astronomer, and from him called the Metonic Cycle. They are likewise surprisingly exact in calcula-

Hindoos. ting the moon's apogee and some of the inequalities of her motion; they know the apparent motion of the fixed stars eastward, and the Siamese tables make it only four seconds too quick; which still shows a great accuracy of calculation, as Ptolemy the celebrated astronomer made an error of no less than 14 seconds in calculating the same thing. M. Cassini, however, informs us, that these tables are not calculated for the meridian of Siam, but for a place $18^{\circ} 15'$ to the westward of it, which brings us very near the meridian of Benares, the ancient seat of Indian learning. This likewise agrees with what the Hindoos call their first meridian, which passes through Ceylon, and the banks of the river Remananur. It must be observed, however, that the geography of the Hindoos is much more inaccurate than their astronomy.

The date of the Siamese tables is not very ancient; and that of the table above mentioned sent from Hindostan by the missionaries is still more modern. These, however, are written in such an enigmatical manner, that the missionary who sent them was unable to tell their meaning; and Mr Playfair supposes that even the Bramins themselves were ignorant of it. Nevertheless they were deciphered by M. le Gentil; who thinks that they have the appearance of being copied from inscriptions on stones. The minutes and seconds are not ranged in vertical columns, but in rows under one another, and without any title to point out their meaning or connexion.

The tables of Trivalore are among the most remarkable of all we are yet acquainted with. Their date, according to Mr Playfair, corresponds with the year 3102 B. C. thus running up to the year of the world 902, when Adam was still in life. This era is famous in Hindostan, under the name of *Calyougham*: and as this extraordinary antiquity cannot but create some suspicion, Mr Playfair has been at some pains to determine whether it is real or fictitious, i. e. whether it has been determined by actual observation, or derived by calculation from tables of more modern date. The result of his labours is, that we are to account the *Calyougham* as determined by observation; and that had it been otherwise, we must have been furnished with infallible methods of detecting the fallacy. His reasons for this opinion are,

1. The task would have been too difficult, even for modern astronomers, to make the necessary calculations without taking into account the disturbances arising from the action of the heavenly bodies upon one another, and with which we cannot suppose the ancient astronomers to have been equally well acquainted with the moderns. By reason of these variations, as well as from the small errors unavoidable in every calculation, any set of astronomical tables will be found prodigiously inaccurate when applied to any period very far distant from the time of observation. Hence, says our author, "it may be established as a maxim, that if there be given a system of astronomical tables, founded on observations of an unknown date, that date may be found by taking the time when the tables represent the celestial motions most exactly." This indeed might be done, provided we were furnished with any set of perfectly accurate tables with which we could compare the suspected ones; and Mr Playfair thinks it "a very reasonable postulatam," that our modern astronomical

Hindoos. tables, though not perfectly accurate, are yet capable of determining the places of the celestial bodies without any sensible error for a longer period than that of the *Calyougham*.

2. By calculation from our modern tables, it appears that the place of the star Aldebaran, at the commencement of the *Calyougham*, differs only $53'$ from what the Indian tables make it. He thinks this coincidence the more remarkable, as the Bramins, by reason of the inaccuracy of their own date, would have erred by four or five degrees, had they calculated from their most modern tables dated in 1491.

3. At the commencement of this epoch (which according to M. Bailly, happened at midnight between the 17th and 18th of February 3102 B. C.) the sun was in $10^{\circ} 3^{\circ} 38' 13''$ by the Indian tables. But the mean longitude of the sun, according to the tables of M. de la Caille, for the same time, comes out to be only $10^{\circ} 1^{\circ} 5' 57''$, supposing the precession of the equinoxes to have been the same at that time as now. M. de la Grange, however, has demonstrated, that, in former ages, the precession of the equinoxes was less than at present: whence there arises an equation of $1^{\circ} 45' 22''$ to be added to the sun's place already mentioned: and thus it will differ only $47'$ from the radical place in the tables of Trivalore. Notwithstanding this reasoning, however, Mr Playfair thinks that no stress is to be laid upon this argument, as it depends on the truth of a conjecture of M. Bailly that the place of the sun above mentioned was not the mean but the true one.

4. The mean place of the moon at Benares, calculated from Mr Mayer's tables, for the 18th of February 3102 B. C. will be $10^{\circ} 0^{\circ} 51' 16''$, provided her motion had all that time been equable: but the same astronomer informs us, that the motion of the moon is subject to a small but uniform acceleration, about $9''$ in 100 years; which, in an interval of 4801 years, must have amounted to $5^{\circ} 45' 44''$; which added to the preceding, gives $10^{\circ} 6^{\circ} 37'$ for the true place of the moon at the commencement of the *Calyougham*. Now the place of this luminary, at that time, by the tables of Trivalore, is $10^{\circ} 6^{\circ}$; the difference is less than two-thirds of a degree, which, for so remote a period, and considering the acceleration of the moon's motion, for which no allowance could be made in an Indian calculation, is a degree of accuracy that nothing but actual observation could have produced.—This conclusion is confirmed by a computation of the moon's place from all the tables to which the Indians could have any access, and of which the enormous errors would instantly show the deception. Thus, by the tables of Ptolemy, the place of the sun would be $10^{\circ} 21' 15''$ greater; and that of the moon $11^{\circ} 52' 7''$ greater than has just been found from the Indian tables. By those of Ulug Beg, the place of the sun would be $1^{\circ} 30'$, and that of the moon 6° , different from what it is by the Indian tables; and in like manner our author shows that the Indian calculations could not be derived from any other set of tables extant. In like manner, he shows that, with regard to the mean place of the moon, there is a coincidence for a period of more than 4000 years between the tables of Mayer and those of India named *Christambouram*; which, though they bear a more modern date than those of Trivalore, are thus probably more-ancient.

Hindoos.

"From this remarkable coincidence (says Mr Playfair), we may conclude, with the highest probability, that at least one set of these observations on which the tables are founded, is not less ancient than the era of the Calyougham: and though the possibility of their being some ages later than that epoch is not absolutely excluded, yet it may, by strict mathematical reasoning, be inferred, that they cannot have been later than 2000 years before the Christian era.

5. Since the time that M. Bailly wrote, every argument respecting the acceleration of the moon's motion has become more worthy of attention, and more conclusive. For that acceleration is no longer a mere empirical equation introduced to reconcile the ancient observations with the modern, nor a fact that can only be accounted for by hypothetical causes, such as the resistance of the ether, or the time necessary for the transmission of gravity; but a phenomenon which M. de la Place has with great ability deduced from the principle of universal gravitation, and shown to be necessarily connected with the changes of eccentricity in the earth's orbit discovered by M. de la Grange: so that the action of the moon is indirectly produced by the action of the planets, which alternately increasing and diminishing this eccentricity, subjects the moon to different degrees of that force by which the sun disturbs the time of her revolution round the earth. It is therefore a periodical inequality, by which the moon's motion, in the course of ages, will be as much retarded as accelerated; but its changes are so slow, that her motion has been constantly accelerated, even for a much longer period than that to which the observations of India extend.—To M. de la Grange also we are indebted for one of the most beautiful of the discoveries in physical astronomy, viz. That all the variations in our system are periodical; so that, though every thing, almost without exception, be subject to change, it will, after a certain interval, return to the same state in which it is at present, and leave no room for the introduction of disorder, or of any irregularity that might constantly increase. Many of these periods, however, are of vast duration. A great number of ages, for instance, must elapse, before the year be exactly of the same length, or the sun's equator be of the same magnitude, as at present. An astronomy, therefore, which professes to be so ancient as the Indian, ought to differ considerably from ours in many of its elements. If, indeed, these differences are irregular, they are the effects of chance, and must be accounted errors; but if they observe the laws which theory informs us they do, they must be held as the most undoubted marks of authenticity.

6. Neither these tables of Trivalore, nor the more ancient ones of Chrisabouram, are those of the greatest antiquity in India. The Bramins constantly refer to an astronomy at Benares, which they emphatically style the *ancient*; and which, they say, is not now understood by them, though they believe it to be much more accurate than that by which they calculate.

so
conclu-
sions by
Mr Play-
fair, con-
cerning the
Indian
astronomy.

From these and other similar arguments, Mr Playfair draws the following conclusions with respect to Indian astronomy. 1. The observations on which it is founded, were made more than 3000 years before the Christian era; and, in particular, the places of the sun and moon, at the beginning of the Calyougham, were de-

termined by actual observation. 2. Though the astronomy now in the hands of the Bramins is so ancient in its origin, yet it contains many rules and tables that are of later construction. 3. The basis of their four systems of astronomical tables is evidently the same. 4. The construction of these tables implies a great knowledge of geometry, arithmetic, and even the theoretical part of astronomy. All this, however, we find controverted, or at least rendered somewhat doubtful, by William Marsden, Esq. who has written a paper on the chronology of the Hindoos, in the Philosophical Transactions for 1790. "The *Kales Yoog* (says he), or principal chronological era, began in the year 3102 B. C. according to the common method of computation, or in 3101 according to the astronomical method, on the 18th of February, at sunrise; or at midnight, according to different accounts, under their first meridian of *Lauka*. At that period it is said to be asserted by their astronomers, that the sun, moon, and all the planets, were in conjunction according to their mean places. The reality of this fact, but with considerable modification, has received a respectable sanction from the writings of an ingenious and celebrated member of the French academy of sciences, who concludes that the actual observation of this rare phenomenon, by the Hindoos of that day, was the occasion of its establishment as an astronomical epoch. Although M. Bailly has supported this opinion with his usual powers of reasoning, and although abundant circumstances tend to prove their early skill in this science, and some parts of the mathematics connected with it; yet we are constrained to question the verity or possibility of the observation, and to conclude rather that the supposed conjunction was, at a later period, sought for as an epoch, and calculated retrospectively. That it was widely miscalculated too, is sufficiently evident from the computation which M. Bailly himself has given of the longitudes of the planets at that time, when there was a difference of no less than 73° between the places of Mercury and Venus. But fifteen days after, when the sun and moon were in opposition, and the planets far enough from the sun to be visible, he computes that all, except Venus, were comprehended within a space of 17° ; and on this he grounds his supposition of an actual observation.

Hindoos.

21
controverted
by Mr
Marsden.

"In their current transactions the inhabitants of the peninsula employ a mode of computation of a different nature, which, though not unknown in other parts of the world, is confined to these people among the Hindoos. This is a cycle, or revolving period, of 60 solar years, which has no farther correspondence with their other eras than that of their years respectively commencing on the same day. Those that constitute the cycle, instead of being numerically counted, are distinguished from each other by appropriate names, which in their epistles, bills, and the like, are inserted as dates, with the months, and perhaps the age of the moon annexed; but in their writings of importance and record, the year of *Salaban* (often called the *Saka* year) is super-added; and this is the more essential, as I do not find it customary to number the cycles by any progressive reckoning. In their astronomical calculations we observe, that they sometimes compute the year of their era by multiplying the number of cycles elapsed, and adding the complement of the cycle in which it commenced,

²³ **Hindoos.** menced, as well as the years of the current cycle; but from hence we are led to no satisfactory conclusion concerning this popular mode of estimating time. The presumption is in favour of its being more ancient than their historical epochs. The present cycle, of which 43 complete years expired in April 1790, began in 1747, with the year of Salaban 1669, and of the grand era 4848. M. le Gentil, to whom Europe is chiefly indebted for what is known of Hindoo astronomy, has fallen into an unaccountable error with regard to the years of this cycle, and their correspondence with those of the Kalee Yoog, as appears by the comparative table he has given of them, and other passages of his work. He seems to have taken it for granted, without due examination, that the years 3600 of the latter must have been produced by the multiplication of the cycle of 60 into itself; and consequently that the first year of this grand era must likewise have been the first of the cycle. But this is totally inconsistent with the fact; the Kalee Yoog began the 13th year of the cycle of 60; and all the reasoning founded on the self-production and harmony of these periods must fall to the ground."

From what Mr Marsden here sets forth, it is plain that we must make very considerable abatements in our confidence of the extreme antiquity of the Hindoos observations. Indeed we can scarce conceive a possibility of reconciling such extravagant antiquity with the authentic histories of which we are possessed, or with those of Scripture. The want of an ancient history of Hindostan leaves us indeed in the dark, and gives room for ingenious and speculative men to indulge themselves in marvellous reveries concerning their antiquity. But the flood, we know, which if it existed at all, could not be but general over the whole earth²⁴, must have destroyed every monument of art and science; and it is surely more reasonable to believe, that M. le Gentil, or the most learned man in the present age, has been mistaken (even though we should not be able to determine the particular manner), than at once to deny the authenticity of all history both sacred and profane, and attempt to evade evidence which no power of reasoning can ever set aside.

²⁴ See the article Deluge.

²⁵ Great skill of the Hindoos in geometry.

It is, however, undeniable, that the progress of the Hindoos in geometry as well as astronomy has been very great in ancient times. Of this a most remarkable instance is given by Mr Playfair, in their finding out the proportion of the circumference of a circle to its diameter to a great degree of accuracy. This is determined, in the *Ayeen Akbery*, to be as 3927 to 1250, and which, to do it arithmetically in the simplest manner possible, would require the inscription of a polygon of 768 sides; an operation which cannot be performed without the knowledge of some very curious properties of the circle, and at least nine extractions of the square root, each as far as ten places of decimals. This proportion of 1250 to 3927 is the same with that of 1 to 3.1416; and differs very little from that of 113 to 355 discovered by Metrus. He and Vieta were the first who surpassed the accuracy of Archimedes in the solution of this problem; and it is remarkable that these two mathematicians flourished at the very time that the *Ayeen Akbery* was composed among the Hindoos. In geography, however, they are much deficient; and it is very difficult to find out the true situation of the me-

ridians mentioned by their authors from what they have said concerning them. ²⁵ **Hindoos.**

The art of painting among the Hindoos is in an imperfect state; nor are there any remains of antiquity which evince its ever being more perfect than it is just now. Their principal defect is in drawing, and they seem to be almost totally ignorant of the rules of perspective. They are much better skilled in colouring, and some of their pictures are finished with great nicety. Their sculptures are likewise rude, and greatly resemble those of the Egyptians. They seem to follow no regular rules in architecture: their temples indeed are filled with innumerable columns, but most of them without any just shape or proportion. They are principally remarkable for their immense size, which gives them an air of majesty and grandeur.

The music of the Hindoos is but little known to Europeans; and the art seems to have made but little progress among them in comparison with what it has done in the western countries; though some of the Indian airs are said to be very melodious. Their musical instruments are very numerous: in war they use a kind of great kettle-drum named *nagar*, carried by a camel, and sometimes by an elephant. The *dole* is a long narrow drum slung round the neck; and the *tam-tam* is a flat kind of drum resembling a *tabor*, but larger and louder. They use also the cymbal, which they name *alan*; and they have various sorts of trumpets, particularly a great one named *tary*, which emits a most doleful sound, and is always used at funerals, and sometimes to announce the death of persons of distinction.

The jugglers among the Hindoos are so expert, that many of the missionaries have ascribed their tricks to supernatural power; and even so late a traveller as Mr Grose seems to be not of a very different opinion. Like the Egyptians, they seem to have the power of disarming serpents of their poison, and there are many strollers who go about with numbers of these animals in bags, having along with them a small bagpipe called *magouty*, which they pretend is useful to bring them from their lurking places. They take the serpents, though of the most poisonous kinds, out of the bags with their naked hands, and throw them on the ground, where they are taught to rear and move about to the sound of their music. They say that this is accomplished by means of certain incantations.

The use of fire-arms appears to have been of great antiquity in India. They are prohibited by the code of Gentoo laws, which is certainly of a very ancient date. The phrase by which they are denominated is *agneester*, or weapons of fire; and there is also mention made of *shet-agnee*, or the weapon that kills an hundred men at once. It is impossible to guess at the time when those weapons were invented among the Hindoos; but we are certain, that in many places of the east, which have neither been frequented by Mohammedans nor Europeans, rockets are almost universally made use of as weapons of war. The Hindoo books themselves ascribe the invention of fire-arms to *Baeshkookerma*, who formed all the weapons made use of in a war betwixt the good and evil spirits. Fire-balls, or blue lights, employed in besieged places in the night-time, to observe the motions of the besiegers, are met with everywhere through Hindostan, and are constructed

constructed in full as great perfection as in Europe. Fireworks also are met with in great perfection; and, from the earliest ages, have constituted a principal article of amusement among the Hindoos. Gunpowder, or a composition somewhat resembling it, has been found in many other places of the east, particularly China, Pegu, and Siam; but there is reason to believe that the invention came originally from Hindostan. Poisoned weapons of all kinds are forbidden in this country.

The Hindoos are remarkable for their ingenuity in all kinds of handicraft; but their utensils are simple, and in many respects inconvenient, so that incredible labour and patience are necessary for the accomplishment of any piece of work; and for this the Hindoos are very remarkable. Lacquering and gilding are used all over the country, and must have been used in very early ages; though in some places the lacquering is brought to much greater perfection than in others.

The principal article of food throughout all Hindostan is rice, and of consequence the cultivation of it forms the principal object of agriculture. In this the most important requisite is plenty of water; and when there happens to be a scarcity in this respect, a famine must be the consequence. To prevent this as far as possible, a vast number of tanks and water-courses are to be met with throughout the country, though in some places these are too much neglected, and gradually going to decay. After the rice is grown to a certain length, it is pulled up, and transplanted into fields of about 100 yards square, separated from each other by ridges of earth; which are daily supplied with water let in upon them from the neighbouring tanks. When the water happens to fall below the level of the channels made to receive it, it is raised by a simple machine named *picoti*, the construction of which is as follows. A piece of timber is fixed upright in the ground, and forked so as to admit another piece to move transversely in it by means of a strong pia. The transverse timber is flat on one side, and has pieces of wood across it in the manner of steps. At one end of this timber there is a large bucket, at the other a weight. A man walking down the steps throws the bucket into the well or tank; by going up, and by means of the weight, he raises it; and another person standing below empties it into a channel made to convey the water into the fields. The man who moves the machine may support himself by long bamboos that are fixed in the way of a railing from the top of the piece of upright timber towards the wall.

A number of other kinds of grain are to be met with in Hindostan, but wheat is not cultivated farther south than 18° latitude. It is imported, however, to every part of the country by the Banjaries. These are a set of people belonging to no particular cast, who live in tents, and travel in separate bodies, each of which is governed by its own particular regulations. They frequently visit towns on the sea-coast, with bullocks loaded with wheat and other articles; carrying away in exchange spices, cloths, but especially salt, which they carry into the inland parts of the country. Some of their parties have several thousands of oxen belonging to them. They are rarely molested, even in time of war, otherwise than by being sometimes pressed into the service of an army to carry baggage or provisions; but

VOL. X. Part II.

for this they are paid, and dismissed as soon as the service is over. The Hindoos themselves are prohibited from going out of the country, under the severest of all penalties, that of losing their cast.—Notwithstanding this, however, it is certain that they do settle in foreign parts in the character of merchants and bankers. Perhaps these may have a toleration from the principal Bramin, or there may be an exemption for people of their profession; but this is not known. At any rate, wherever they go, they appear inviolably attached to their religious ceremonies, and refuse to eat what is prohibited to them in their own country. The Ryots, or people who cultivate the ground, are in many places in the most miserable situation; their only food being some coarse rice and pepper, for which they are obliged to endure all the inclemencies of a burning sun, and the inconveniencies which attend alternately wading in water and walking with their bare feet on the ground heated intensely by the solar rays; by which they are frequently blistered in a miserable manner. All this, however, they submit to with the utmost patience, and without making any complaint, expecting to be released from their sufferings by death; though even then their religion teaches them to hope for nothing more than what they call *absorption into the essence of the Deity*; a state almost synonymous with what we call *annihilation*.

HINDOSTAN, a celebrated and extensive country of Asia, bounded on the north by Great and Little Thibet; on the south, by the hither peninsula of India, part of the Indian sea, and bay of Bengal; on the west, by Persia; and on the east, by Thibet, and the farther peninsula. It is situated between 84° and 102° of east longitude, and between 21° and 36° of north latitude; being in length about 1204 miles, and in breadth 960; though in some places much less.

This country was in early times distinguished among the Greeks by the name of *India*, the most probable derivation of which is from *Hind* the Persian name. We are assured by Mr Wilkins, that no such words as *Hindoo* or *Hindostan* exist in the Sanscrit or learned language of the country; in which it is named *Bharata*, a word totally unknown to Europeans. The first accounts we have of Hindostan are from Herodotus, who lived 113 years before the expedition of Alexander the Great. His accounts, however, convey very little information, as he appears only to have heard of the western part of the country, and that on account of its being tributary to Persia. He informs us, that Darius Hystaspes, about 508 B. C. had sent Scylax of Caryandra to explore the river Indus. He set sail from Caspatyrus, a town near the source of the Indus, and the territories of *Pactya* (which Major Rennel supposes to be the modern *Fekhely*), and continued his course eastward to the sea; then altering his course to the west, he arrived at that place where the Phœnicians had formerly sailed round the continent of Africa; after which Darius subdued the Indians, and became master of that sea. The northern inhabitants of India, he says, resembled the Bactrians in their manners, and were more valiant than the rest; these far to the southward were as black as the Ethiopians, killed no animals, but lived chiefly upon rice; and clothed themselves with cotton. By the expedition of Alexander,

3 P

Hindustan. the Greeks acquired a little more knowledge of the country of Hindostan, though he did little else than march over the tracts described by Herodotus. He was informed of the existence of the river Ganges, which had not been known to Herodotus; and the story of his supposing that he had discovered the source of the Nile, when near the head of the Indus, is well known, as well as his surprise and consternation when he arrived at the mouth of that river, on account of the high tides. Major Rennel is of opinion that both these stories are falsehoods. He thinks it is impossible that Alexander could have been ignorant of the writings of Herodotus, who gave an account of the discoveries of Scylax; and with regard to the other circumstance he expresses himself as follows. "The story of Alexander's surprise at seeing the tides in the Indus, appears to me equally improbable; seeing that the same Herodotus, book iii. speaks very particularly of the tides in the Red sea, and describes them as being not only strong, but ebbing and flowing every day. (That most intelligent and ingenious traveller M. Volney informs us, that the tide ebbs and flows three feet and a half at Suez). Arrian takes no notice of the tides until Alexander's fleet had arrived near the mouth of the river. It is true, the tide of the Indus does not go up so high as in other rivers of equal bulk, and that run on so small a descent; but nevertheless, as the tide is perceptible at 50 or 60 miles above the river's mouth, we may conclude, that it could hardly escape the notice of Alexander and his people in their voyage from Pattala to the sea, supposing they had not been apprised of the circumstance. Besides, Arrian's account of the tide which did so much mischief to the fleet, is descriptive of the bore, or sudden influx of the tide, in a body of water elevated above the common surface of the sea; such as occurs in the Ganges, &c. He says, those ships which lay upon the sand were swept away by the fury of the tide; while those that stuck in the mud were set afloat again without any damage. To the generality of readers no reason will appear why the circumstances of the ships should be different in the mud and on the sand: the fact is, that the bottoms of channels in great rivers are muddy, while their shallows are formed of sand; and it is the nature of the bore to take the shortest cut up a river, instead of following the windings of the channel; consequently it must cross the sand banks it meets in its way, and will also prove more destructive to whatever it meets with aground than what is afloat." For an account of the exploits of Alexander in Hindostan, see the article MACE-

4
History from the time of Alexander to that of the Mogul Mehammedans.

The Grecian expedition into India soon excited a general curiosity in the Europeans to become acquainted with a country so wealthy and so remote. Megasthenes, the ambassador of Seleucus, resided long at Palibothra the capital of an Indian nation, and from him the ancient writers learned most of what they know concerning that part of the world. He lived about 300 years before the Christian era, and kept a journal during the time he resided in India.

For some short time the western provinces of India continued subject to the Syrian empire founded by Seleucus; but he quickly ceded these distant countries to one Sandrocottus, who gave him only 500 elephants in exchange. Soon after this the provinces of Bac-

tria likewise became independent; and thus the connection betwixt India and the western parts of the world was entirely dissolved, and we are almost entirely ignorant of the transactions of that country till the time of the Mohammedan conquest. That the extensive country we now call Hindostan was divided among many different nations, we have no reason to doubt; but Major Rennel is of opinion, that however this might be the case, there was generally a large empire or kingdom, which occupied the principal part of that immense valley through which the Ganges takes its course; the capital of which has fluctuated between Delhi and Patna, as the limits of the empire have varied. This was named the kingdom of the *Praji* or *Gangaride* in the times of Alexander and Megasthenes. Major Rennel is of opinion that it extended westward to the Panjab country; and he also thinks it probable that the capital named *Ralibothra* stood on the same spot which is now occupied by the city of Patna. The kingdom, according to this supposition, would occupy part of Bengal; and he thinks that it could not be less than that of France. It was on the borders of this kingdom that Alexander's army mutinied and refused to proceed any farther. Arrian informs us, that the people were rich, excellent soldiers, and good husbandmen; that they were governed by nobility, and that their rulers imposed nothing harsh upon them.

The Hindoos themselves pretend to an extravagant antiquity; but we are informed by Major Rennel, that "there is no known history of Hindostan (that rests on the foundation of Hindoo materials or records) extant before the period of the Mohammedan conquests; for either the Hindoos kept no regular histories, or they were all destroyed, or secluded from common eyes by the Pundits. We may judge of their traditions by that existing concerning Alexander's expedition; which is, that he fought a great battle with the emperor of Hindostan near Delhi, and though victorious, retired to Persia across the northern mountains; so that the remarkable circumstance of his sailing down the Indus, in which he employed many months, is sunk altogether. And yet, perhaps, few events of ancient times rest on better foundations than this part of the history of Alexander, as appears by its being so highly celebrated, not only by contemporaries, but by several of the most eminent authors for some centuries following. The only traces of Indian history we meet with are in the Persian historians. In the beginning of the 17th century, Mohammed Ferishta composed a history of Hindostan, most of which was given in that of Colonel Dow, published upwards of 30 years ago; but with regard to the early part of it, Major Rennel is of opinion that it cannot at all be depended upon.

The authentic history of Hindostan commences with the conquests of Mahmud or Mahmood Gazni, about the year 1000. His kingdom had arisen out of that of the Saracens, who under the caliph Al Walid had extended their conquests immensely both to the east and west. Mahmud was the third from Abistagi, a governor of Khorasan, who had revolted from the king of Backbaria. He possessed great part of that country formerly known by the name of *Bactria*. Gazni, Gazna, or Ghizni, was the capital; a city which stood near the source of the Indus, though Balkh likewise claimed this honour. Subactagi, the father of Mah-

5
No ancient Hindoo history to be credited.

6
Expedition of Mahmud Gazni into India.

nd; had projected the conquest of the western part of India; but dying before he could put his designs in execution, Mahmud took upon himself the conduct of the expedition; but previous to his invasion of India, he strengthened himself by the conquest of the whole of the ancient Bactria. His first invasion took place in the year 1000; during which he made no farther progress than the province of Moulton. That part of the country was inhabited by the Kuttry and Rajpoot tribe, the Malli and Catheri of Alexander, who still retained their ancient spirit, and made a very stout resistance to the armies of that furious enthusiast. As he was prompted to this undertaking no less by a desire of exterminating the Hindoo religion than by that of conquest; a league was at last formed against him among all the Indian princes from the banks of the Ganges to the Nerbudda. Their allied forces, however, were defeated, and the year 1008 was marked by the destruction of the famous temple of Nagracat in the Panjab country. Having satiated himself with plunder on this occasion, Mahmud returned to his own country; but in 1011 invaded Hindostan once more, destroying Tanfar a city on the west of Delhi, and a more celebrated place of worship than Nagracat itself. Delhi was reduced on this occasion; and in seven years after Canoge was taken; the temples of Matra or Methura, the Methora of Pliury, a city of great antiquity, and remarkable for a place of worship near Agra, were likewise demolished; but he failed in his attempts on the Rajpoots of Agimere, either through their own valour or the strength of their country. His twelfth expedition took place in the year 1024, when he destroyed the celebrated temple of Sumnaut in the peninsula of Guzerat; adjoining to the city of Puttan on the sea-coast, and not far from the island of Diu; now in the hands of the Portuguese. In this expedition he proved very successful, reducing the whole peninsula of Guzerat; with many cities, the temples of which he constantly destroyed; and indeed seemed no less pleased with the overthrow of the Hindoo religion than with the conquest of the country. At his death, which happened in 1028, he was possessed of the eastern and by far the largest part of Persia, and nominally of all the provinces from the western part of the Ganges to the peninsula of Guzerat; as well as those lying between the Indus and the mountains of Agimere; but the Rajpoots in that country still preserved their independency, which they have done all along, even to the present time.

In the year 1158 the empire of Gazna fell to pieces from the same causes by which other large and unwieldy states have been destroyed. The western and largest part, which still retained the name of Gazna, was seized upon by the family of Gaurides, so named from Gaur or Ghor, a province beyond the Indian Caucasus; while those contiguous to both shores of the Indus were allowed to remain in the possession of Chusero or Cusroe, whose capital was fixed at Lahore. In 1184 the posterity of this prince were driven out of their territories by the Gaurides; by which means the Mohammedans became neighbours to the Hindoos, and in a short time began to extend their dominions to the eastward. In 1194 Mohammed Gori penetrated into Hindostan as far as Benares, and repeated the same scenes of devastation which had for-

merly taken place under Mahmud Gazni. At this period Major Rennel is of opinion, that the purity of the language of Hindostan began to decline, and continued to do so till it became what it is at present; the original dialect being what is called the Sanserit, and which is now a dead language. Mohammed Gori also reduced the southern part of the province of Agimere, and the territory to the south of the river Jumna, taking possession of the strong fortress of Gualior. After his death in 1205, the empire of Gazna was again divided; and the Patan or Afghan empire was founded by Cuttub, who had the Indian part, the Persian remaining to Eldoze. Cuttub fixed his imperial residence at Delhi; and in 1210 the greatest part of Hindostan Proper was conquered by the emperor Altumish, the successor of Cuttub. After his time the government of Bengal was always bestowed upon one of the reigning emperor's sons; and during his reign the bloody conqueror Jenghiz Khan put an end to the other branch of the Gaznian empire, known by the name of *Kharasm*; of which revolution an account is given under the article GAZNA; but Hindostan was at that time left undisturbed. In 1242 the Moguls began to make irruptions into Hindostan, but did not at this time make any permanent conquest. The country was now in much the same state in which it had been before the invasion of the Mohammedans, viz. divided into a great number of states tributary to the emperor, but in a great measure independent; and which did not fail to revolt whenever a favourable opportunity offered. The kingdom of Malwa, which had been reduced by Cuttub in 1205, shook off the yoke in the year 1265, and the Rajpoots were on every occasion ready to revolt, notwithstanding that their country lay in the neighbourhood of the capital. The most dreadful massacres, rebellions, and confusion, now took place, which, from that period almost to the time that the British government commenced, made up the history of Hindostan. The empire being parcelled out among a set of rapacious governors, the people were reduced to the last degree of misery, and were at last so far misled as to imagine that it was their interest to take up arms, in order to render these governors independent. Had the emperors of Hindostan consulted their true interest, they would have given up the provinces which lay beyond the upper part of the Indus and the deserts of Agimere; as these formed a barrier which could not easily be passed by any invader. By neglecting this precaution, however, they at last gave an opportunity to the Moguls to penetrate into their country; and these, after several invasions, became at last so formidable, that they were permitted by the emperors, in the year 1292, to settle in the country. At this time the reigning emperor was Ferose II. of the tribe of *Chittigi* or *Killigi*, so named from Killige near the mountains of Gaur; and in 1293 this emperor projected the conquest of the Deccan; by which was meant at that time all the territory lying to the southward of the Nerbudda and Mahanada and Catta-
tack rivers; an extent of dominion almost equal to all that he already possessed in Hindostan. Ferose was incited to attempt this by the riches of one of the princes of Deccan; and the person who proposed it was one Alla, governor of Gurrab, a country nearly bordering upon that which he was about to invade.

Hindostan. Alla, having accomplished his undertaking, during which he amassed an incredible quantity of treasure, deposed and murdered the emperor, assuming to himself the sovereignty of Hindostan. He then began a new plan of conquest; and the first instance of his success was the reduction of Guzerat, a strong fortress, which had hitherto remained independent, and, while it continued so, was a strong obstacle to his designs upon the Deccan. He next reduced Rantanpour and Cheitore, two of the strongest forts in the Rajpoot country. In 1303 the city of Warangole, capital of a kingdom of the Deccan named Tellingana, was reduced; but in the midst of these conquests the Moguls invaded the country from an opposite quarter, and plundered the suburbs of Delhi. Notwithstanding this check the emperor resumed his plan of conquest; the remainder of Malwa was subdued; and in 1306 the conquest of the Deccan was again undertaken. The conduct of the war was now committed to Cafoor; who not only carried his army into Dowlatabad, but, in 1310, penetrated into the Carnatic also. The extent of his conquests in that country is not known; and indeed his expeditions seem to have been made with a view rather to plunder than to achieve any permanent conquest. The quantity of riches he amassed was so great, that the soldiers are said to have carried away only the gold, leaving silver behind them as too cumbersome. As the treasure carried off on this occasion had been accumulating for a number of ages, it is probable that the country had long remained in a state of tranquillity.

10
Revolts and
confusion
throughout
the whole
empire.

Cafoor still proceeding in his conquests, ravaged a second time the northern part of the Deccan, and obliged the inhabitants of Tellingana and the Carnatic to become tributary to him. Rebellions took place in 1322; but the country was again reduced in 1326, and the whole Carnatic ravaged from one sea to the other. This year Alla died, and his successors, not being possessed of his abilities, were unable to retain the dominions he had left. Under the emperor Mohammed III. the people of the Deccan again revolted, and drove the Mohammedans so completely out of these countries, that nothing remained to them but the fortress of Dowlatabad. In 1344 the city of Biannagar, properly *Bijainagar*, was founded by Belaldeo the king of Deccan, who had headed the inhabitants in their late revolt. Mohammed in the mean time attempted to extend his dominions towards the east; but while he employed himself in this, many provinces were lost by rebellions in Bengal, Guzerat, and the Panjab. His successor Ferose III. who ascended the throne in 1351, seemed more desirous of improving the remains of his empire than of extending it; and, during his reign, which continued for 37 years, agriculture and the arts were the favourite objects of his pursuit. After his death, in 1388, a rebellion and civil war took place, and continued for several years; and matters were brought to a crisis in the time of Mahmud III. who succeeded to the throne in 1393; and, during this time, the empire of Hindostan exhibited the singular circumstance of two emperors residing in the same capital, and in arms against each other. While matters remained in this situation, Tamerlane, after having subdued all the western part of Tartary and Asia, turned his arms against Hindostan in the year

11
Conquests
and mas-
sacres of
Tamerlane.

Hindostan. 1398. His conquest was easy, and his behaviour such as rendered him worthy of the name by which he is yet known in Hindostan, "the destroying prince." After having brought into captivity a vast number of the poor inhabitants, he caused a general massacre to be commenced lest they should join the enemy in case of any sudden emergency; and in consequence of this cruel order, upwards of 100,000 were put to death in one hour. In the beginning of the year 1399 he was met by the Indian army, whom he defeated with great slaughter, and soon after made himself master of the imperial city of Delhi. At this time the capital consisted of three cities, named *Old Delhi*, *Seyri*, and *Jehan Penah*. Seyri was surrounded with a wall in the form of a circle; and Old Delhi was the same, but much larger, lying to the south-west of the other. These two were joined on each side by a wall: and the third, which was larger than the other two, lay between them. As the city made no resistance, there could not be a pretence for using the inhabitants with any cruelty: and thus matters passed on quietly till the 12th of January, when the Tartar soldiers insulted some of the inhabitants at one of the gates. The Emirs were ordered to put a stop to these disorders, but found it impossible. The Sultanas, having a curiosity to see the rarities of Delhi, and particularly a famous palace adorned with 1000 pillars built by an ancient Indian king, went in with all the court; and the gate being thus left open for every body, above 15,000 soldiers got in unperceived. But there was a far larger number of troops in a place between the cities above mentioned, who committed such disorders, that an insurrection commenced; some of the inhabitants attacking them, while others, in despair, set fire to their houses, and burnt themselves with their wives and children. The soldiers, taking advantage of this confusion, pillaged the houses; while the disorder was augmented by the admission of more troops, who seized the inhabitants of the neighbouring cities that had fled to Delhi for shelter. The Emirs caused the gates to be shut; but they were quickly opened by the soldiers, who rose in arms against their officers; so that, by the morning of the next day, the whole army had entered, and the city was totally destroyed. Some soldiers carried off no fewer than 150 slaves, men, women, and children; nay, some of their boys had 20 slaves a-piece to their share. The other spoils in jewels, plate, and manufactures, were immense; for the Indian women and girls were all adorned with precious stones, and had bracelets and rings on their hands, feet, and even toes, so that the soldiers were loaded with them. On the 15th the Indians attempted to defend themselves in the great mosque of Old Delhi; but being attacked by the Tartars, they were all slaughtered, and towers erected. A dreadful carnage now ensued throughout the whole city, though several days elapsed before the inhabitants could be forced to quit it entirely; and as they went, the Emirs took many of them into their service. The artisans were also distributed among the princes and commanders, all but the masons, who were reserved for the emperor, in order to build him a large stone mosque at Samarcand.

After this terrible devastation, Tamerlane marched into the different provinces of Hindostan, everywhere defeating the Indians who opposed him, and slaughtering

ing the Ghebrs or worshippers of fire. On the 25th of March he retired, and thus set the miserable inhabitants free from the most bloody conqueror that had ever invaded them. He did not, however, disturb the succession to the throne, but left Mahmud in quiet possession of it, reserving to himself only that of the Panjab country. The death of Mahmud, which happened in 1413, put an end to what is called the Patan dynasty, founded by Cuttub in 1205. He was succeeded by Chizer, who derived his pedigree from the impostor Mohammed, and his posterity continued to enjoy it till the year 1450; when Belloli, an Afghan of the tribe of Lodi, took possession of it, the reigning prince Alla II. having abdicated the government. Under him all Hindostan was divided into separate states; and a prince, whose title was the *king of the east*, who resided at Jionpour in the province of Allahabad, became so formidable, that the king of Delhi had only a shadow of authority remaining to him. A considerable part of the empire, however, was recovered by the son of Belloli; who, in the year 1501, fixed his royal residence at Agra. During his reign the Portuguese first accomplished the passage to India by the Cape of Good Hope, but they had no connection with any other part of Hindostan than some maritime places in the Deccan which had always been independent of the court of Delhi. In 1561, during the reign of Ibrahim II. matters fell into such confusion that Sultan Baber, a descendant of Tamerlane, found means to conquer a very considerable part of the empire. His first expedition took place in the year 1518; and the year 1525 he made himself master of Delhi. In his last invasion he is said to have brought with him only 10,000 horse; having been furnished with the rest by the disaffected subjects of the emperor. During the five years that he reigned, his chief employment was the reduction of some of the eastern provinces; but he had not time to compose the disturbances which took place throughout the whole of his dominions. On his death the seeds of rebellion, which Baber had not been able to exterminate, produced so many revolts and insurrections, that his son Humaïoon, though a prince of great abilities and virtue, was driven from the throne, and obliged to take shelter among the Rajpoot princes of Agimere, where he lived in great distress. During the time of his exile his son Akbar was born, whom Mr Rennel looks upon to be one of the greatest princes that ever sat on the throne of Hindostan. The sovereignty was held in the mean time by an usurper, named Sheerkhan, who in 1545 was killed at the siege of Cheitore, and buried in a magnificent mausoleum, of which Mr Hodges has exhibited a drawing in this country. His territories, at the time of his death, extended from the Indus to Bengal; but so unsettled was the government, that after his decease no fewer than five sovereigns appeared in the space of nine years. This induced a strong party in Hindostan to recal Humaïoon; but he lived only one year after his return.

In 1555, Humaïoon was succeeded by his son Akbar, at that time only 14 years of age. During his long reign of 51 years, he established the empire on a more sure foundation than it had probably ever been before; though even at this time Mr Rennel is of opinion, that all the tranquillity enjoyed by the people was

merely that there was no actual rebellion. The first Hindostan years of his reign were spent in reducing the provinces which had revolted from Agimere to Bengal; and the obedience of these he took care to secure as well as possible by a careful choice of governors; particularly by an unlimited toleration in religious matters, and an attention to the rights and privileges of the people. In 1585, he resolved to invade the Deccan, which had hitherto resisted the power of the Mogul princes. The war continued for 20 years; during all which time no farther progress was made than the reduction of the western part of Berar, Candeish, Tellingana (a division of Golconda), and the northern part of Amednagar; the capital of which, named also *Amednagar*, was taken in 1601, after a long and bloody siege, and an unsuccessful attempt of the princes of the Deccan to relieve it. Under his successor Jehan Guire, the project was but faintly carried on; the empire was disturbed by the rebellion of Shah Jehan the emperor's son; and the influence of Noor Jehan his mistress perplexed the councils of the nation. In this prince's reign Sir Thomas Roe, the first English ambassador, arrived at the court of Hindostan. The Portuguese had now acquired considerable possessions in Guzerat and Bengal, but only those in the former provinces attracted the attention of the court; so that the Persian historian takes no notice of those in Bengal. In the reign of Shah Jehan, who succeeded his father Jehan Guire in 1627, the conquest of the Deccan was more vigorously pushed than before; and the war was carried on in such a destructive manner, that most of the princes in those parts were fain to make submission to the emperor. During this reign a war took place with the Portuguese, which ended in the expulsion of the latter from Hoogly on the Ganges. In his private character Shah Jehan was a very debauched and wicked prince, which gave occasion to one of his sons named *Aureng-zib*, or *Aureng-zebe*, to dethrone him. This prince attained his end by a train of deep hypocrisy and dissimulation; covering his ambition with a pretence of religion, and under that pretence committing the greatest crimes. He engaged in a war with two of his brothers, both of whom he defeated by unforeseen accidents, when he himself seemed to be on the brink of destruction. Having at last got them into his power, he put them both to death, and then lamented their misfortunes. One of his brothers who assisted him, was rewarded first with imprisonment, and then with death. By the year 1660, he had attained full possession of the sovereignty, and from that time to the year 1678 there reigned a profound tranquillity throughout the whole empire. In the latter part of his reign he undertook the conquest of the Deccan, to which he was supposed to be incited by the resolution and growing power of Sevagee, the founder of the Mahratta state; and who, in that character, appeared almost as a rival to Aureng-zebe himself. Having quelled a rebellion of the Patans, who lived beyond the Indus, he persecuted the Hindoos to such a degree, that the Rajpoot tribes in Agimere commenced a war against him. On this occasion he headed his armies also in person; but having the misfortune to be hemmed in among the mountains, he would certainly have been taken prisoner, had not the enemy thought proper to allow him to escape. They allowed also the empress to make her escape, after she had been actually taken.

Hindustan taken. In 1681, he renewed his incursions into that country, took and destroyed Chectore, committing other devastations, and everywhere destroying the Hindoo temples and objects of worship; but notwithstanding all his efforts, he was at last obliged to abandon his enterprise, and allow them to remain in peace. From the year 1678 to the time of his death in 1707, he is said to have been chiefly employed in the Deccan, the greatest part of which he reduced, and for the last five years of his life is said to have been actually employed in the field. This long absence from his capital could not but be productive of bad consequences. Rebellions broke out in various parts of the empire; and during this period, the Jats or Jaits first made their appearance in the province of Agra. They were at first only a set of banditti; but have since grown to be a very considerable state, and once were of some consequence in Upper Hindostan. After the 10th year of Aureng-zebe's reign, however, we know very little of his transactions, as he would not allow any history of it to be written. At the time of his death the empire extended from the 10th to the 35th degree of latitude, and almost as many degrees in longitude. "His revenue (says Major Rennel) exceeded 35 millions of pounds sterling, in a country where the products of the earth are about four times as cheap as in England. But so weighty a sceptre could be wielded only by a hand like Aureng-zebe's; and we accordingly find, that in the course of 50 years after his death, a succession of weak princes and wicked ministers reduced this astonishing empire to nothing."

15
Its quick
decline un-
der his suc-
cessors.

Aureng-zebe left four sons; Mausum, afterwards emperor, under the title of Bahader Shah; Azem, Kaum Bush, and Acbar, who had been obliged to fly to Persia 30 years before, on account of his having engaged in rebellion against his father. A civil war instantly commenced between Azem and Mausum; the event of which was decided in a great battle, where 300,000 combatants were brought into the field on each side. In this battle Azem was defeated and killed; after which Mausum ascended the throne by the title of Bahader Shah. He was a prince of considerable abilities; but the disorders of the empire were already risen to such an height, that during his short reign of five years, he found it impossible to compose them. He was first engaged in war with his brother Kaum Bush, whom he also defeated and killed; after which his attention was engaged by the Seiks, a new set of religionists, who, during the reign of Shah Jehan, had silently established themselves along the foot of the eastern mountains. They now appeared in arms in the province of Lahore, and ravaged the whole country from thence to the banks of the Jumna. The emperor marched against these adversaries in person, and with great difficulty brought them under subjection. He then took up his residence at Lahore, where he died after a short illness, without having ever visited the imperial cities of Agra or Delhi.

After the death of Bahader Shah the empire was again contested among his four sons. Of these the second, named Azem Ooshaun, took possession of the treasures; but was opposed by his three brothers, who agreed to divide the empire among them. Azem was defeated and killed in a battle, gained chiefly by the valour and conduct of the youngest named *Shah Jehan*;

who seemed resolved to abide by the agreement, and as Hindustan a proof of his sincerity, ordered the treasures to be divided. This was prevented by the intrigues of Zoolfecar-khan, an omrah in high trust. A new civil war commenced, in which Jehan Shah was killed. The two remaining brothers tried their fortune in a third battle, which left Jehauder, the eldest, in possession of the throne. In nine months he was dethroned by Feraksere, or Furroksere, son to the deceased Azem Ooshaun; having, during his short reign, displayed almost unparalleled meanness of spirit.

This revolution was accomplished by the assistance of two brothers, Houssein Ali Khan and Abdoolis Khan, who had extensive governments in the eastern provinces. The calamities of the empire were not at all abated during this reign. In 1713 the Seiks appeared again in arms; and in 1716 were grown so formidable, that the emperor himself was obliged to march against them; but we are totally ignorant of the particulars of this campaign. About this time the ¹⁶ *Firman* English East India Company obtained the famous *Firman* granted to *man* or grant, by which their goods of export and import were exempted from duties or customs; which was regarded as the company's commercial charter in India, while they stood in need of protection from the princes of that country.

Feroksere was deposed, and his eyes put out, by the two brothers who had raised him to the throne; and in the course of the same year two other emperors, whom they afterwards set up, were deposed and murdered; and thus, in eleven years after the death of Aureng-zebe, 11 princes of his line, who had either mounted the throne, or been competitors for it, were exterminated, while the government declined with such rapidity, that the empire seemed ready to be dismembered to a greater degree than it had even been before the invasion of Tamerlane. In 1719 the two brothers raised to the throne Mohammed Shah, the grandson of Bahader Shah; but this prince having got sufficient warning by the fate of his predecessors, took care to rid himself of these powerful subjects, though this could not be accomplished without a civil war. New enemies, however, started up. Nizam-al-Mulk, viceroy of the Deccan, had been for some time augmenting his power by every possible method, and was evidently aspiring at independence. Having received some affronts from the two brothers, who for some time had ruled every thing with an absolute sway, he thought proper to retire to his government. In 1722 he was invited to court, and offered the place of vizier or prime minister, but declined accepting it, while the growing and formidable power of the Mahrattas furnished him with a pretence for augmenting his army. At last, having by the year 1738 attained a sufficient degree of strength to accomplish his purposes, and confident of his having a large party at court, he came thither attended by a great body of armed followers. Finding, however, that the interest of the emperor was still too powerful for him, he invited the celebrated Persian ¹⁷ usurper Nadir Shah, commonly known by the name *of Kouli Khan*, to invade Hindostan. The invitation of Nadir was accepted, and Nadir entered the country without *Shah* opposition. The imperial general Douran being killed in a skirmish, no decisive engagement took place; and the Persian chief, though far advanced into Hindostan,

Hindostan. yet looked upon matters to be so uncertain, that he offered to evacuate the country and retire for 50 lacks of rupees, about half a million sterling. The intrigues of the Nizam and his party hindered the emperor from complying with this moderate demand; instead of which he absurdly threw himself upon the usurper's mercy, who then took possession of Delhi, demanding a ransom of 30 millions sterling. At an interview with the emperor, he severely reprimanded him for his misconduct; however, he told him, that as he was of the race of Timur (Tamerlane), who had not offended the reigning family of Persia, he would not take the empire from him; only as he had put him to the trouble of coming so far to settle his affairs, he insisted that his expences should be paid. The unfortunate emperor made no answer to this speech; but Nadir took care to enforce the latter part of it. Some time after the departure of the emperor, Nadir went to the camp to pay him a visit; where he seized upon 200 cannon, with some treasure and valuable effects, sending them off immediately to Candahar. He then marched back to Delhi, where a mob arose about the price of corn. As Nadir Shah was endeavouring to quell it, a musket was designedly fired at him, by which he narrowly escaped being killed. Exasperated at this, he commanded an indiscriminate massacre to be made, which his cruel soldiers instantly put in execution with the greatest alacrity, and 120,000, or, according to others, 150,000, of the miserable inhabitants were slaughtered without mercy. This was followed by a seizure of all the jewels, plate, and valuable articles which could be found, besides the exaction of the 30 millions, which was done with the utmost rigour; insomuch that many of the inhabitants chose rather to put an end to their own lives than to bear the torments to which they were subjected in case of inability to pay the sum imposed upon them. During these horrid scenes, Nadir caused the marriage of his son to be celebrated with a grand-daughter of Aureng-zebe; and after having extorted every thing which he demanded, at last took leave of the emperor with every mark of friendship. He put the crown upon his head with his own hands; and after having given him some salutary advice relative to the government of his empire, he set out from Delhi on the 6th of May 1739.

18
Inhabitants
of Delhi
laughter-
ed.

19
Miserable
state of
Hindostan
after his
departure.

By this invasion the empire sustained prodigious loss. Since the arrival of Nadir in Hindostan, about 200,000 people had been destroyed, and goods and treasure carried off to the amount of 125 millions sterling. Mohammed had ceded to the usurper all the provinces of Hindostan situated to the west of the Indus. His departure left the Nizam in possession of all the remaining power of the empire, which he instantly made use of to establish himself in the sovereignty of the Deccan. The province of Bengal had already become independent under Aliverdy Cawn, in the year 1738; and not long after, it was invaded by a vast army of Mahrattas under sanction of the emperor's name; who being unable to satisfy them in the arrears of tribute he had been obliged to consent to pay, sent them into Bengal to collect for themselves. About the same time, the Rohillas, a tribe from the mountains which lie between India and Persia, erected an independent state on the east of the Ganges, within 80 miles of Delhi.

The total dissolution of the empire seemed now to

be fast approaching. In the confusion which took place after the murder of Nadir Shah, Abdallah, one of his generals, seized upon the eastern part of Persia, and the adjoining provinces of India, which had been ceded to Nadir by Mohammed Shah; which he formed into a kingdom still known by the name of *Candahar* or *Abdalli*; of which a more particular account is given in the subsequent part of this article.

This year Mohammed Shah died, after a reign of 29 years; which, considering the fate of his immediate predecessors, and the anarchy universally prevalent throughout Hindostan, must be accounted very wonderful. He was succeeded by his son Ahmed Shah; during whose reign, which lasted about six years, the total division of the remainder of the empire took place. Nothing now remained to the family of Tamerlane but a small tract of territory round the city of Delhi, now no longer a capital, and exposed to the repeated depredations of invaders, with consequent massacres and famines. The last army which could with propriety be termed *imperial*, was defeated by the Rohillas in 1749; by which their independence was fully established in the eastern parts of the province of Delhi. The Jats, or Jats, a Hindoo tribe, established themselves in the province of Agra; the Deccan and Bengal were seized upon by their viceroys, Nizam and Aliverdy. Oude was seized on by Seifdar Jang (father to the late Sujah Dowlah); Allahabad by Mohammed Kooli. Malwa was divided between the Poonah Mahrattas and several native princes and zemindars: Agimere reverted of course to its ancient lords, the Rajpoot princes; and the Mahrattas, in addition to their proper share of Malwa, possessed the greatest part of Guzerat, Berar, and Orissa; besides their ancient dominions in the Deccan. These people were now become so powerful, that they were alternately courted and employed by the contending parties, like the Swiss in Europe; with this difference, that the Swiss are paid by those who employ them, whereas the Mahrattas always take care to pay themselves. Abdallah having established his empire in the manner above related, entered Lahore and Moulton, or the Panjah, with a view to conquest. "The whole country of Hindostan was in commotion (says Major Rennel) from one entrance to the other, each party fearing the machinations or attacks of the other; so that all regular government was at an end, and villany was practised in every form. Perhaps in the annals of the world it has seldom happened that the bonds of government were so suddenly dissolved, over a portion of country containing at least 60 millions of inhabitants."

20
First inter-
succeeded by his son Nazirjung, to the prejudice of his serene-
eldest brother Gazi, vizier to the nominal emperor. The French
The contest that followed on this occasion for the throne of the Deccan, and nabobship of Arcot, first engaged the French and English as auxiliaries on opposite sides. This was followed by a long series of hostilities, which terminated in the total expulsion of the French from Hindostan, the entire humiliation of the Mogul, and his being reduced to the state of dependence on the English East India Company; together with the subjection of a vast tract of country to the latter. These transactions have occasioned very considerable revolutions, not only in the country properly called

Mindostan. *Hindostan*, but in other places : for an account of which, and of some later revolutions, see the articles INDIA in this work, and in the SUPPLEMENT.

21
Different powers among which Hindostan is divided.

The vast country of Hindostan, before the revolution, alluded to, was divided among the following powers.

1. Timur Shah, son of Ahmed Shah, or Abdallah, possessed an extent of territory to the north-westward before we come to the river Indus. This country, extending all the way betwixt India and Persia, is known by the name of *Duran*, or *Turan*; and was possessed by the Afghans, of whom Abdallah became the sovereign. He was descended from an illustrious family; and having the misfortune of being taken prisoner by Hussein Khan, then chief of Candahar, along with his brother Zulfecur Khan, they were released by the celebrated Nadir Shah in his passage through that country to Hindostan; but as that conqueror still looked upon them with a jealous eye on account of their great influence with their countrymen, both were sent to Mazandaran in Persia. Here Zulfecur Khan, the brother of Ahmed, died; and, some time after, we find the latter promoted to the command of a body of Afghan cavalry in the Persian army. He continued attached to the interests of Nadir while that conqueror lived; and even attempted, though ineffectually, to revenge his death. Proving unsuccessful in this attempt, he returned to his own country; and, arriving at Candahar, was saluted chief of the Afghans. In the course of a few months he became master of all the countries which the Mogul had been obliged to cede to Nadir Shah; and, encouraged by the distracted state of the affairs of Hindostan at that time, he crossed the Indus, and plundered the country to the south-east. An indecisive battle fought with the Indian army under the command of the prince royal and vizier, in which the latter was killed, obliged Ahmed to return to his own territories; but he soon undertook another expedition, in which he conquered the province of Lahore. In 1755 he returned; and after staying some time at Lahore, marched to Delhi the capital, having been invited thither, as was supposed, by the Mogul himself, in order to get rid of the tyranny of his vizier. The latter was accordingly deserted in a battle by orders of the emperor, and obliged to surrender himself prisoner; but instead of being put to death, he had the address to ingratiate himself with the conqueror; and the unfortunate Allumghire, the Mogul, was obliged to submit to be ruled by him as before. Ahmed took care to indemnify himself for his trouble, by laying the city of Delhi under a heavy contribution; and having staid for about a month, during which time he concluded a marriage betwixt his son Timur and the emperor's niece, he marched against a tribe of Hindoos named the *Jauts*, and conquered the greatest part of the province of Agra. In this expedition he surprised the city of Matra, famous for being the birth-place of *Krishen*, the Apollo of the Hindoos; and sacrificed to the *Gopia*, the muses of the country. He failed in his attempt to surprise Agra through the resolution of Fazil Cawn the governor; after which he led back his troops to Delhi, where he married the daughter of Mohammed Shah the late emperor, whom Allumghire had in vain solicited for himself.

Having settled his son Timur in the government of

Lahore, Ahmed quitted Hindostan, and returned to his dominions, where he found every thing in confusion. Timur, who during his father's absence had been frequently disturbed by the Seiks, a tribe of Hindoos who profess deism, was in 1760 driven out by a vast army of Mahrattas commanded by Ragonaut Row the Peishwa's brother, of whom so much mention has already been made. Next year, however, Ahmed crossed the Indus, and easily recovered his former territories; soon after which he became head of a league formed among some of the Indian princes, in order to oppose the overgrown power of the Mahrattas. In this enterprise he proved successful; and overthrew the Mahrattas in a decisive and very bloody battle, in which more than 50,000 of them were killed on the spot. The pursuit lasted several days, and their vast army was totally dispersed; Ahmed being everywhere received with acclamations as the deliverer of the faithful. In 1762 he again crossed the Indus, with a view to conquer, or rather to exterminate, the Seiks, whose incursions had become very troublesome, and even dangerous to his kingdom. Having defeated their army, and forced them to take refuge in the woods and strong holds, he set a price on the heads of all those who professed their tenets; and that with such success, that heaps of them are said to have been piled up in all the principal towns in these parts. At last, hearing that they had assembled in great numbers to celebrate an annual festival, he marched with an army to surprise them. The Seiks, however, were well provided for his reception, and an obstinate battle ensued. During the time of the engagement an eclipse of the sun happened, which, though disregarded by the Seiks, greatly dismayed the superstitious Moham-medans. Ahmed was therefore defeated; and though he frequently returned, was never able thoroughly to subdue that people. At last, having been long afflicted with an ulcer in his face, he died on the 15th of July 1773, at a place named *Kohtoba*, among the mountains of Candahar, to which he had retired for the sake of coolness, and was succeeded by his son Timur, who still continues to enjoy the sovereignty. The dominions of this prince extend a very considerable way to the northward of the Indus, but he possesses nothing in Hindostan besides the province of Kashmere.

2. The Seiks inhabit a country on the other side of the Indus, and making part of Hindostan properly so called. They derive their origin from a Hindoo named *Nanuck* of the cast of *Khatry*. His father, named *Baba Caloo*, possessed a small district in the province of Lahore named *Telvandi*, where Nanuck was born in the year 1470. Like other founders of new sects or nations, he is said during his infancy to have given many indications of his future superiority to the rest of mankind. He seems, however, to have received no farther education than what was common to young men of his cast, viz. reading, writing, and arithmetic, and hearing the sastras or commentaries on the sacred books. In his early youth he was married to a woman of his own cast, by whom he had two sons. Being a convert to the worship of the Invisible, or deism, he accustomed himself to declaim against the folly of worshipping idols, and the impiety of paying adoration to any but the Supreme Being. At the age of 25 he left

his

indostan. his family to visit Bengal, and the eastern parts of Hindostan; in a second journey he visited the southern, and in a third he went as far as Persia and Arabia. On his return from this last journey, he expressed a desire of remaining in his native country; and was furnished, according to his wish, with a piece of ground on the banks of the river Bavy, about 80 miles north-eastward from the city of Lahore. Here he took up his residence for the rest of his days; and choosing to be free from the cares of this world, he dwelt at a distance from his wife and children, who came occasionally to visit him. Having acquired great reputation for his piety, wisdom, and learning, he died at the age of 70; and since his death the place of his abode has obtained the name of *Dihra Daira*, or "the place of worship." His eldest son founded a sect of devotees named *Nanuck Shoiy*; but his second employed himself in the usual occupations of mankind. On account of the oppression of the Mohammedan governors, however, he removed from Telvandi, the estate of his ancestors, and settled at Kartarpour, which his descendants still possess. They are respected by the Seiks on account of their being the posterity of Nanuck, but are not held in any veneration on a religious account.

The doctrines of Nanuck were taught by a favourite disciple of his named *Lhina*, but on whom he bestowed on his deathbed the appellation of *Angud*. By him the doctrines of the sect were collected in a work named *Pothy*, or "the book;" and an history of the life of Nanuck himself was given in another named *Jenum Sakky*. Both these were written in a particular kind of character called *Gour Mouekty*; and said to have been invented by Nanuck himself. Angud named for his successor another disciple called *Amerdoss*; and this method of continuing the succession seems to have been practised as long as the disciples continued to own one supreme chief.

For many years the Seiks lived in peace, and gained the good-will of the Mohammedan governors by their quiet and inoffensive behaviour. By degrees their numbers and their power greatly increased, but in proportion to their good fortune, they seem to have lost their virtue; so that their gourous, or chiefs, who had hitherto borne the character of apostles, at last stood forth as military leaders. The first of these was named *Taigh*, whose successor, named *Govand Sing*, was the tenth and last of the gourous. He engaged in a rebellion against the government; but was at last obliged to submit, and even attended the emperor Bahader Shah in person. At last he was assassinated by a Petan soldier, not without a suspicion of the emperor himself being concerned. As he did not name a successor, his followers chose a chief for themselves named *Banda*, who soon began to make depredations on his neighbours; but being at last taken prisoner, and sent to Delhi with his family and many of his countrymen, they were all put to an ignominious death. By this execution the Seiks were so much exasperated, that they avowed eternal vengeance against the Mohammedans, and have ever since manifested a most implacable hatred against them. Taking advantage of the distraction of the Mogul empire by the invasion of Nadir Shah, they conquered several provinces. Wherever they came they threw down the mosques, and obliged every one to quit the country

who refused to embrace their tenets. The war with Hindostan. Ahmed Shah has been already mentioned. Since his death they have recovered all the territories they lost during their contest with him; and now possess the greatest part of Moultan, as well as several districts in the province of Delbi; including in their territories the whole of that rich country named the *Panjab*, on account of five rivers which descend from the northern mountains, and inclose or intersect it, running afterwards into the Indus.

The Seiks, as has already been mentioned, worship one God; but without image, or believing in any mediator. They eat all kinds of meat except beef; sparing the black cattle, in all probability, on account of their utility. Pork is very generally eaten, probably on account of its being forbidden by the Mohammedans. They are commonly dressed in blue, a colour reckoned unlucky by the other Hindoos. Their dress consists of blue trowsers of cotton, a sort of plaid generally chequered with blue and thrown over the right shoulder, with a blue turban. Their government is lodged in an assembly of different chiefs, but who as individuals, are independent of one another, and have separate territories. They meet annually, or oftener if occasion requires, at a place called *Aniberser*, which is held in a kind of religious veneration; where there is a large tank lined with granite, and surrounded with buildings, and beautifully ornamented. Their force is very considerable, amounting to no fewer than 200,000 cavalry. However, they can seldom be brought to act in concert, unless the whole nation be threatened with some imminent danger. They are a strong hardy race of men, and capable of bearing much fatigue; and so expert in war, that of late almost all the neighbouring countries have been laid under contribution by them, several petty chiefs having consented to pay them a small annual tribute in order to avoid their incursions. When in the field, none but the principal officers have tents, and those extremely small, so that they may be struck and transported with the greater quickness and facility. In cold weather the soldiers wrap themselves during the night in a coarse blanket, which in the time of marching is folded and carried on their horse. Their country is well cultivated, populous, and abounding in cattle, particularly horses, which are reckoned the best in all Hindostan. This may probably be owing to the studs which were formerly established in different places of the province of Lahore on account of the Mogul himself. Stallions were sent thither from Persia and Arabia, and there was a fixed order to send to the studs in Lahore all such Arabian and Persian horses as by any accident should be rendered unfit for mounting. Notwithstanding their deism, the Seiks are said to have a superstitious veneration for their sword; inasmuch, that before one of them will eat with a person of another religion, he draws his sword, and passing it over the victuals, repeats some words of prayer, after which he will freely partake of them. Contrary to the practice of all the other Hindoos, they dislike the smoking of tobacco; but many of them smoke and chew bang, which sometimes produces a degree of intoxication.

3. The provinces of Delhi have, in the course of a few years, frequently changed their masters, but have

Hindustan scarce at any period during that time been under the authority of the sovereign. Their last governor was named *Nadjiff Khan*, under the title of generalissimo of the emperor. He was involved in the ruin of Mohammed Kouly Khan, cousin to Soujah al Dow'ah; after which he went to Cassim Aly Khan nabob of Bengal; after whose expulsion he retired with a party of horse to Bundelcund into the service of Rajah Coman Sing. He next joined the English; and at last became the general of Shah Allum. With a body of English seapoys who had been put under his command, and some other troops whom he had taken into his service, he subdued the countries near Delhi, conquered almost all the territories of the Jauts, reducing the cities of Agra, Dieg, and other principal towns. These conquests were indeed effected in the name of the Mogul, but he derived little benefit from them; *Nadjiff* being the real master, and keeping possession of them till his death, which happened in 1782: and since that time the countries we speak of have been involved in a scene of continual anarchy and bloodshed.

4. Next to the provinces of Delhi are the dominions of the independent rajahs, whose dominions lie contiguous to one another. The principal are those of Joinagar, or Jaypour, Joadpour, or Marwar, Ondiapour or Chitore, and Jesalmire. These countries are under a kind of feudal constitution, and every village is obliged to furnish a certain number of horseman at the shortest warning. The people are brave, hardy, and very much attached to their respective chiefs; and their army is very formidable, amounting when collected to about 150,000 horsemen.

5. The Jauts were a tribe who followed the occupation of agriculture in the northern part of Hindostan. About 40 years ago they were formed into a nation by Tackou Souragemul, proprietor of an inconsiderable district. After making himself master of all the countries dependant on Agra, of the town itself, and many other important places, he was killed in battle with *Nadjib ul Dowlah*, the Rohilla chief, in 1763. Since that time the power of this people has been so much reduced by domestic contentions and foreign wars, that the present rajah possesses only a strong town named *Bartpoor*, with a small district around it. The Jauts, however, it is said, are now manifesting a martial disposition, and thus may possibly be soon in a condition to recover their former extent of territory.

6. The most considerable of all the Hindoo powers are the Mahrattas, with whom the Europeans first became acquainted in their original territories of Malabar. The first of their chiefs was named *Seeva*, or *Secva-jee*; who is said to have been descended from the ancient Hindoo emperors, and whose father was lord of a small district, for which he paid tribute to the Mohammedan king of Viziapour. For some reason, unknown to us, he was at last arrested by order of that king, and died in confinement; but his son *Seeva-jee* took up arms in defence of his country, and made himself master of several important places, with a considerable tract of territory, which were afterwards ceded to him by the queen regent, the king of Viziapour having died soon after the commencement of the war.

Seeva-jee having thus established himself, soon became formidable to his neighbours. Many of the Hindoo

princes put themselves under his protection, and he at length ventured to make war upon the emperor Aurengzebe. In this he proved unsuccessful, was taken prisoner, and carried to Delhi. Having found means, however, to make his escape, he quickly recommenced hostilities; and the emperor, who was now far advanced in life, thought proper to come to an accommodation with so troublesome an enemy. On this occasion the Mahrattas pretend that their prince obtained a grant of 10 per cent. on all the revenues of the Deccan; which has often served as a pretence to invade that country, and levy contributions on the southern nabobs. Since that time the Mahrattas have become so powerful, that all the princes of Hindostan are alarmed when they put themselves in motion. Their territories extend about 1000 miles in length and 700 in breadth; and they are governed by a number of separate chiefs, all of whom acknowledge the Ram Rajah as their sovereign, and all except *Moodajee Booslab* acknowledge the *Paishwa* as his vicegerent. The capital of the sovereign was *Sattarah*; but the *Paishwa* generally resides at *Poonah*, one degree to the southward, and about 100 miles distant from *Bombay*. The country extends along the coast nearly from *Goa* to *Cambay*. On the south it borders on the territories of *Tippoo Saib*; on the east it has those of the *Nizam* and the rajah of *Berar*; and on the north those of the Mahratta chiefs *Sindia* and *Holkar*.

7. The rajah of *Berar*, besides that country, has the greatest part of *Orixa*. His dominions extend about 600 miles in length from east to west, and 250 from north to south. The eastern part of *Orixa* extends along the sea-coast for about 150 English miles, and divides the British possessions in *Bengal* from those commonly called the *Northern Circars*. On the west his territories border upon those of the *Paishwa*; and on the south, upon those of the *Nizam*, *Mahomet Hyat* a Patan chief, *Nizam Shah*, and *Ajid-Sing*. The rajah himself resides at *Nagarpour*, about midway betwixt *Calcutta* and *Bombay*.

8. *Madajee Sindia*, has the greatest part of the government of *Malva*, together with the province of *Can-deish*. The remainder is under the government of *Holkar*; who, as well as *Sindia*, pretends to be descended from the ancient kings of *Malva*. The principal residence of *Sindia* is at *Ugein* near the city of *Mundo*, which was once the capital of these kings. *Holkar* resides at *Indoor*, a town little more than 30 miles to the westward of the former. The dominions of these, and some other princes of smaller note, extend as far as the river *Jumna*.

The two last-mentioned princes, though properly Mahrattas, own no allegiance to the Ram Rajah, or great chief to whom the main body are nominally subject. Some time ago the Mahrattas aimed at the conquest of all Hindostan, and even avowed a design of expelling all the Mohammedan princes; but their power was effectually checked by the British, and their dissensions among themselves put an end to all schemes of that kind. Still, however, they were ready to watch every opportunity of invading the territories of their neighbours; and their resources being so considerable, they were deservedly accounted a very formidable enemy. The strength of their army consists chiefly in cavalry; and both men and horse are capable of enduring a great deal

Hindustan. deal of fatigue. Bodies of 50 or 60,000 cavalry have been known to travel 50 miles a day for many days together; which, considering the excessive heat of the country, must certainly appear very surprising. The country abounds very much in horses, and there is one kind named the *Bheemerteddy* horse, which is greatly esteemed, and sold at a very high price. The common horse of these parts is lean and looks ill, but is abundantly fit for the purposes of war. The only weapon used by the horsemen is a sabre; in the use of which they are so dexterous, that it is supposed the best European hussar would not be more than a match for a Mahratta horseman. There are considerable studs in every province belonging to the Paishwa and different chiefs; and there are likewise many *jundis* or great herds of horses belonging to particular persons, who turn those they have no occasion for loose in the open plains.

The Mahratta horsemen are dressed in a quilted jacket of cotton, which is supposed to be one of the best defences against a sword that can easily be contrived of equal lightness; but the heat of the climate frequently renders it necessary to be taken off. The rest of their dress consists of a pair of trowsers, and a kind of broad turban which descends low enough to cover the neck and shoulders. In cases of emergency the horsemen carry provision both for themselves and their horses in small bags tied upon the saddles: the food of the rider consists only of a few small cakes with a little flour or rice, and some salt and spices; the horse is fed with a kind of pease named *gram*, or with balls made of the flour of these pease mixed with butter, prepared after a certain manner, and named *ghee*, together with some garlic and hot spices. These balls are given by way of cordial, and have the property of invigorating the animal after extraordinary fatigue. Sometimes it is said that they add a small quantity of *bang*; a kind of drug which possesses an exhilarating virtue, and produces some degree of intoxication. The Mahratta cavalry seldom make any use of tents; even the officers frequently have no other accommodation than a small carpet to sit and lie on; and a single camel is able to carry the whole baggage of the general. The officers, however, are generally well mounted, and have spare horses in the field.

All the subjects and vassals of the Mahratta princes are generally ready to follow them into the field; and in any case in which the honour or interest of the nation appears to be concerned, they generally unite in the common cause. Before they invade any country, the general is at great pains to inform himself of the nature and situation of it: and they have now made incursions into so many different parts of Hindostan, that there are very few countries there with which they are not very well acquainted. Their great sobriety, and the fatigue they are capable of undergoing, render them very dangerous enemies. In all their expeditions the soldier first provides for his horse, and then goes to his own meal; after which he lies down contented by the side of the animal, and is ready to mount him at the first sound of the *nagar* or great drum. They have their horses under the most excellent management; and by perpetually caressing and conversing with them, the animals acquire a degree of docility and sagacity unknown in other countries.

Hindustan. When on an expedition, the horses are accustomed to eat grass pulled up by the roots, which is said to be very nutritive, and to be destitute of that purgative quality which belongs to the blade alone. When they make an invasion, the devastation is terrible; the cattle are driven off, the harvest destroyed, the villages burned, and every human creature destroyed who comes in their way. Notwithstanding this barbarity in time of war, however, they are very humane in time of peace, living in great harmony among themselves, and being always ready to entertain and assist strangers. Many of the cruelties they commit may be justly reckoned the effects of retaliation for other cruelties exercised upon them by their adversaries. Thus, in 1771, after having given Hyder Ally a great defeat, they cut off the ears and noses of a whole regiment of prisoners, and in that condition sent them back to their commander, in return for his having done the same to a few prisoners he had taken some time before.

The revenue of the Paishwa is very considerable; being not less than ten millions sterling; but after deducting the expence of collection, and the expence of troops kept in readiness for the service of the state, it is supposed that he cannot receive more than four millions. From this again we must deduct the expences of the troops immediately belonging to the Paishwa himself, and which may amount to about three millions sterling; so that there remains a surplus only of one million after paying all the necessary expences of government. This nevertheless has been managed with such economy, that though long and expensive wars were carried on after the death of Narrain Row, the state was not only clear of debt, but there was a surplus of two millions in the treasury, which Rogobah dissipated.

9. The *Deccan*, as left in 1748 by Nizam al Mulek, was by far the most important and extensive soubadary or viceroyship in the empire. It then surpassed in size the largest kingdom in Europe; but since that time many provinces have been conquered by the Mahrattas, and the northern Circars by the British. The possessions of the Nizam are also diminished by the cession of the Carnatic to the nabob of Arcot; great part of the territories of Tippoo Saib; and many other provinces of less note. Still, however, the Nizam possesses very considerable territories; but his finances are in such a wretched condition, and his provinces so ill governed, that he is accounted a prince of no consequence, though otherwise he might be reckoned one of the most considerable powers of Hindostan.

10. The dominions of Tippoo Saib, the son and successor of Hyder Ally, are bounded on the north by the territories of the Paishwa; on the south by Travancore, the territory of an independent Hindoo prince; on the west by the sea; and on the east by a great ridge of mountains, which separate them from the territories of the nabob of Arcot. The country lying to the eastward of these mountains is called the Carnatic *Payen Ghat*, and to the westward the Carnatic *Bhalla Ghat*. The latter belongs to Tippoo Saib; and the two together make up the country formerly named the *Carnatic*, though the name is now restricted to the *Payen Ghat*. —The situation of the *Bhalla Ghat* is considerably more elevated than the other; by which means the temperature of the air is much cooler. On the

Hindustan. coast of Coromandel there is a pile of ruins called by the natives *Malvipatam*, and by the British *the seven pagodas*. Concerning this there is a tradition, that it once stood at a considerable distance from the sea, though most of the ruins are now covered with water; and there is likewise a tradition, that the mountains we speak of once formed the boundary of the ocean. The revenue and strength of Hyder Ally are said to have been greatly exaggerated: the former amounting to no more than four millions annually, though by his economy and good management he made it answer every purpose both in time of war and peace. He was at great pains to introduce the European discipline among his troops; but notwithstanding all his endeavours, he was far from being able to make them cope with the British. The advantages he gained were owing to his vast superiority in cavalry, and the celerity of his marches; which would have been counteracted had his adversaries been possessed of a good body of cavalry; and it is probable that the event of the war would have been decided in a single campaign. His son Tippoo Saib is said to have been a man of less abilities than his father, though more violent in his disposition. Against this prince hostilities commenced by the British in conjunction with the Mahrattas, between whom an alliance had been formed. Tippoo Saib himself fell a victim to his own misguided bravery at the siege of Seringapatam, which surrendered to the British on the 4th of May 1799.

22
Govern-
ment of
Hindustan.

With regard to the present government of Hindostan, our limits will not allow us to enter particularly upon it, nor indeed is it perhaps of any importance, as the country is divided into so many different kingdoms, the sovereigns of which, however they may differ in other respects, seem all to agree in despotism and oppression of their subjects. As a very considerable part is now under the dominion of Britain, it may be necessary to take some notice of the behaviour of our countrymen in that part of the world, especially as an idea of their excessive despotism and oppression of the natives has of late prevailed so much, that the national character has suffered considerably by it. This has arisen partly from the great pains taken to propagate it, and partly from the ignorance of those among whom the report was circulated; and the exaggerated accounts and contentions of the members of the government themselves, have contributed no less to confirm and heighten the prejudices of the public.

23
Defenses of
the British
govern-
ment in the
east.

The British territories in the East Indies were originally under the jurisdiction of a governor and 13 members; but this number has fluctuated occasionally from 14 to 4, at which it was fixed by act of parliament. In this council all matters, whether relating to peace or war, government or commerce, were debated, the governor having no other superiority than that of giving the casting vote. In other respects the whole executive power was lodged in his hands, and all the correspondence with the native princes of India was carried on by his means, the dispatches to them being signed by him singly; and all the princes and great men who visited the presidency were first received by him, and then introduced to the counsellors. He was military governor of Fort William, and commander in chief of the presidency; whence, as by his office he was invested with a considerable degree of power, he

became an object of some envy and jealousy to the members of the council and other considerable people in that part of the world. In consequence of this, the government was divided into two parties, one siding with the governor, and the other opposing him; in consequence of which, the debates were frequently carried on with such heat and violence, that the records of the company were frequently stuffed with nothing but accounts of the contentions of these jarring parties. This indeed may be looked upon as one of the principal causes by which the reputation of the British government in the eastern parts of the world has suffered; for as there were very frequently opinions diametrically opposite to one another recorded upon the same subject, the contending parties in the British parliament had always sufficient authority for what they said, let them take which side they would: and thus the characters of all concerned in the East India government were, by one person or other, set forth in the most opprobrious light.

Another source of reproach to the British government in India was, that the court of directors in England became infested with the same spirit of party and contention which pervaded all other departments of the state. Lord Clive and Mr Sullivan were the two great leaders of these party disputes; and as the interest of the one or the other prevailed, different persons were appointed to the administration, and different measures adopted. The event of all this was, that whenever a new administration was formed, the first object was to condemn the measures of those who had gone before him. Thus, in the year 1764, when Lord Clive was made governor of Bengal, the new directors represented the affairs of the company as in the worst situation imaginable, from which they could only be extricated by the abilities of Clive. On the arrival of the latter in the east, he took care to write home reports to the same purpose, and to condemn in the most violent manner every thing that had been done; the whole body of the company's servants were censured indiscriminately without being allowed any means of defence, as they were in truth ignorant of the charges brought against them. When the affairs of the company were brought under a parliamentary review in the year 1774, the government was brought under a new regulation. It now consisted of a governor-general and four counsellors; three of whom were sent from England; two being military gentlemen of high rank, and the third a gentleman employed in the war-office. On their arrival they proceeded in the same manner that Lord Clive had done before them: they pronounced in the most decisive manner, that the company's affairs were in a ruinous state; and that every species of corruption had been practised by the former government. This general accusation, unsupported by any kind of evidence, was the constant theme of the dispatches sent by them to England; and thus has the reputation of the British government suffered exceedingly through the unwarrantable liberties which its own servants have been allowed to take with one another. It must also be considered, that from the remote situation of India, and the unavoidable ignorance of its affairs on that account, it was easy for any person, whose malicious purposes it might suit, to prejudice the public against the servants of the company

company to as great a degree as he pleased. Hence some persons, scoured by disappointment, or envious of the supposed emoluments of others, represented matters in such an unfair light to their correspondents in England, that the most unjust and shameful charges were frequently brought against innocent persons, which they could neither prevent nor defend themselves against. The dreadful famine which took place in Bengal in the year 1769, offered to those malevolent persons a most fruitful source of calumny; and many individuals were accused of having brought on this dreadful calamity, which arose entirely from a natural cause, viz. the failure of the rains, and which no human power could have prevented or removed.

Opinions of this kind have not only been circulated through the island of Britain in the most open manner, but have even appeared in some very respectable publications. Thus, in Dr Smith's Treatise on the Wealth of Nations, when speaking of the oppression arising from monopolies, and comparing their effects in different states: "The English company (says he), have not yet had time to establish in Bengal so perfectly destructive a system. The plan of the government, however, has had exactly the same tendency. It has not been uncommon, I am well assured, for the chief, that is, the first clerk of a factory, to order a peasant to plough up a rich field of poppies, and sow it with rice or some other grain. The pretence was to prevent a scarcity of provisions; but the real reason, to give the chief an opportunity of selling at a better price a large quantity of opium he had on hand. Upon other occasions the order has been reversed, and a rich field of rice or other grain has been ploughed up to make room for a plantation of poppies, when the chief saw that extraordinary profit was to be made by opium." To this, however, the following answer has appeared in a late publication, entitled A short Review of the British government in India. "The poppy is a plant which requires a peculiar soil, and particular care in the culture of it. The medium price of the land on which it is cultivated is about 11 or 12 rupees a *begah*, or one-third of an English acre. It is sowed at the beginning of October, when the season of the periodical rain expires. The plant begins to be fit for incision, in order to extract its juice, of which opium is made, about the end of December, and continues so till March. It requires a dry soil, and can be brought to maturity only in the dry season, when the periodical rains have ceased. Paddy or rice lands let on a medium at three rupees a *begah*. Rice is sowed about the end of May, just before the periodical rains commence. One crop is raised about the end of September; and another, which is the last, and by far the greatest, about the end of December. It requires a soil saturated with water, and lies soaked in it for a considerable time. On this account it is sowed just before the periodical rains commence; and nine-tenths of the quantity of rice produced in the company's provinces grow in the kingdom of Bengal, which is so low and flat, that the grounds are either overflowed by the rivers Ganges and Burrampooter, with their tributary streams, or soaked with the rain which falls and stagnates upon them. It is therefore evident, that the soil and the season, which alone can fructify the paddy or rice, would rot and destroy the poppy; and it is there-

fore as evident, that it is utterly impossible, from the nature of the two plants, that the one can be ploughed up to sow the other." Hindustan

With regard to the administration of the British affairs in the East Indies, it must also be remarked, that the company now act in a very different capacity from what they originally did. From a society of merchants, they are now become sovereigns of the country to which they trade. The latter character was quite foreign to them; and they have accordingly looked upon that of merchants to be the principal one, while that of sovereigns was to be only a kind of appendage to it. Thus, instead of acting for the interest of the country they govern, and which as sovereigns they naturally ought to do, they have acted in many cases directly opposite to it, which, as merchants, is also their natural interest. Hence also, when the administration in India did any thing in obedience to the orders of the directors, which orders being dictated by merchants, were prejudicial to the interests of the country, that injury has been sometimes unjustly attributed to their servants, who acted merely in obedience to the orders they received. On the other hand, when the India administration acted with the generous spirit of sovereigns, they were sometimes blamed by the directors, who judged as merchants, and sometimes by the ministry, who were always ready upon the smallest pretence to interfere in their affairs.

At the time when the British administration first commenced in Hindostan, the Hindoo governors were universally named *rajahs*; but though many of the Hindoo families yet bear that title, it does not appear to resemble, in any manner of way, our titles of nobility, or to be a dignity which can be conferred by any of the princes, or even by the Mogul himself. Hence, in that part of the world there are no ancient nobility, the titles being conferred merely by usurpers, who have neither right nor title derived from any thing but violence.

In this country we find the title of *zemindar* very common; a word compounded of two others, signifying, in the Persian language, a *landholder*. It appears to have been introduced by the Mohammedans, and to have been a kind of temporary office, prescribing the performance of certain duties, and requiring security for the personal appearance of the zemindar. He is obliged to attend the exchequer of the king's chief collector, at the commencement of every new year, to settle his revenues; and he is not allowed to enter upon the duties of his office for the year without a special order for that purpose. On the death of a zemindar, the candidate for succession must petition the sovereign, engaging himself to perform all the stipulated duties, and to pay the customary fees; nor can he enter upon his office without a special investiture. As the zemindars were by virtue of their office invested with considerable power, they soon became not only very despotic in their own dominions, but by degrees began to encroach on the power of the sovereign himself. After the irruption of Nadir Shah every thing was thrown into confusion: the viceroys threw off obedience to the emperor, the nabobs threw off all obedience to them, and usurped their power; at which time it is probable that the zemindars likewise assumed powers to which they were by no means intitled.

Hindustan, titled from their office. Notwithstanding this, however, they were sometimes treated by the Mohammedan governors as mere revenue-officers, and used very harshly. At some times there were a set of people bound for the zemindars under the title of *woodedars*; and these had either a joint power with the former, or were superior to them in the collection of the revenues; and sometimes they were superseded by officers appointed immediately by government itself, under the various names of *amils*, *tahsilders*, or *sezauruls*.—The zemindaries are not limited in extent or value; there being some in Bengal which yield a revenue as high as 350,000l. sterling, while others scarcely amount to 350l.; but all the great zemindars, and many of these in middling circumstances, having procured for themselves the title of *rajah*, affect much pomp and state in their different districts, and keep their inferiors in as great subjection as the Mohammedan governors keep them. Some of them also have their power augmented by being of the Bramin cast; and by the reverence supposed to be due to religion on that account, joined with the power conferred upon them by the sovereign, they are in general rendered exceedingly despotic, with an almost unlimited authority to plunder their tenants; in which they were indulged by the nabobs, from the motive of plundering them again. From the consultations of the select committee in 1769, we are informed that the zemindars have a power of levying fines at pleasure; that they raise large sums from duties collected in the market; and that they frequently oblige the ryots or husbandmen to work for nothing. In short, the same claims made by the European barons on their vassals in the times of the feudal system, are now made by the zemindars on the common people of Hindostan. If one of them is to be married, if he has a child born, if honours are to be conferred upon him; nay, if he is even to be fined for his own misconduct, the poor ryot must always contribute his share. Mr Scroston, in his history of Hindostan, sets forth the situation of the inhabitants in the following words:—"Unhappily for the Gentoos, themselves are made the ministers of oppression over each other; the Moor-men, haughty, lazy, and voluptuous, make them, of whom they have no jealousy, the ministers of their oppression, which further answers the end of dividing them, and prevents their uniting to fling off the yoke; and by the strange intoxication of power, they are found still more rapacious and cruel than their foreign masters: and what is more extraordinary, the Bramins still exceed the rest in every abuse of power, and seem to think, if they bribe God by bestowing a part of their plunder on cows and faquirs, their iniquities will be pardoned."

From this account of the situation of the people of Hindostan under their native rulers, it is by no means probable that they could make a worse exchange by falling under the jurisdiction either of the Mohammedans or Europeans. A notion indeed hath been industriously propagated, that the British government has behaved with the greatest cruelty in collecting the revenues, and that they have even invented tortures to make the rich people discover their treasures; but on examining the matter impartially, the reverse of this is found to be true. At the time that the British government in-

terfered in the affairs of Hindostan, the provinces were found to be in a ruinous state, in consequence of the wars which had taken place in the country. Even in the most settled state, and when the administration was most regular, the government was altogether despotic, and the mode of collecting its revenues extremely arbitrary; the punishments inflicted very cruel; and the whole system of government such as would be reckoned quite shocking in Europe. It is only within these few years that the British could effectually interpose in behalf of the natives; and in that short time it has produced a very considerable reformation. It is certain, that the British government has discouraged oppressive measures as much as possible; abolished the cruel modes of punishment used by the Mohammedans; and by instituting a more regular plan of justice, has procured ease and security to the natives, and preserved them in a state of tranquillity altogether unknown to them before its commencement. Many instances of the greatest cruelty exercised upon the zemindars and other collectors are to be met with in the history of Bengal, written by a native historian, and translated by Gladwin: yet the person who exercised these cruelties was dignified with the titles of the *faithful servant of the Empire*, and the *Glory of the State*; which shows that the people were absolutely familiarised with cruelty, and did not know what it was to be under a lenient government. Since the British had the dominion, matters have been totally reversed, and the Hindoos, instead of being treated with cruelty, persecuted on account of their religion, and compelled to renounce it, have been used with at least comparative lenity, and great indulgence has been shown to them even in their most absurd practices and superstitions. When the British government first accepted of the office of dewanny, or collector of the revenues, it was not in their power to interpose with any kind of efficacy for the relief of the inhabitants; because it was at first thought proper to allow the taxes to be collected by natives, who would undoubtedly follow their ancient modes of collection. Even at that time, however, the mildness of the British governors had some effect upon the Asiatics; so that the people in general were treated with more lenity than formerly: and in the year 1772, when the council of Bengal openly assumed the office of dewan themselves, an immediate stop was put to all those arbitrary and oppressive methods which had been formerly in use. Formerly some zemindars had been flogged even to death, by an instrument called a *korah*: but from the moment that the British council took the collection into their own hands, not only this instrument was laid aside, but all kind of corporal punishment; by which means the severity of the Mohammedan government has been entirely abolished, and no other punishments inflicted in cases of insolvency than such as are in use in our own country. Still, however, in such extensive dominions, where a great share of power must be one way or other committed to the natives, it is impossible but some arbitrary acts must be committed, as the natives are always prone to acts of despotism whenever they can commit them with impunity; but examples of this kind cannot with any degree of candour be brought as a general charge against the British government in India.—Mr Scroston gives the following account of the wretched state of the

the provinces now under the British jurisdiction at the time they were ceded to them by the Mogul. "When the governors of the provinces found the weakness of the Mogul, and each set up as sovereign in his own province, although they could not break through these immutable laws, they invented new taxes under new names, which doubled or trebled the value of the original ones, and which the landholder was obliged to levy upon his tenants. The old stock of wealth for some time supported this; but when that failed, and the tenants were still pressed for more, they borrowed money of usurers at an exorbitant interest; and the government still continuing these demands, the lords of the lands were obliged to do the same: but as all this while the value of lands did not increase, the consequence was, that at last, unable to pay the interest of the mortgages, the rents were seized by rapacious usurers. The government finding the revenues fall shorter every year, at last sent collectors and farmers of the revenues into the provinces. Thus the lord of the land was divested of power over his country, and the tenants exposed to merciless plunderers; till the farmer and manufacturer, finding that the more they laboured the more they paid, the manufacturer would work no more, and the farmer would cultivate no more than was just sufficient for the subsistence of his family. Thus this once flourishing and plentiful country has, in the course of a few years, been reduced to such misery, that many thousands are continually perishing through want. The crown lands are still worse off, let out to the highest bidder; and the Jagheer lands alone remain unplundered. Hence that equal distribution of wealth that makes the happiness of a people, and spreads a face of cheerfulness and plenty through all ranks, has now ceased; and the riches of the country are settled partly in the hands of a few usurers and greedy courtiers, and the rest is carried out of the country by the foreign troops taken into pay to maintain the governors in their usurpations. This unhappy decay the India company has already experienced in the decay of their trade, and the rise and price of their manufactures; and will, I fear, experience more and more annually."

With regard to the depositions of the nabobs by the British, which has been used as a great argument against the general spirit of British government in those parts, it must be remembered, in the first place, that these nabobs were mere usurpers, who had not the least title to their dominions, and consequently could not, in point of right, complain more reasonably of being deprived of their dominions, than the persons from whom they had taken them might do of their injustice in driving them out. Their behaviour in government also was such, that it was impossible it could have subsisted for any length of time without the absolute ruin of the countries they possessed. Thus, in the case of Jaffier Ally Cawn, Mr Vansittart declared the country to be in so confused and impoverished a state, that in all human appearance another month could not have been run through before he would have been cut off by his own seapoys for want of pay, and the city become a scene of plunder and disorder. On this account he was degraded, though without any of those circumstances of cruelty which generally characterise the revolutions in this part

of the world. The administration was transferred to his son-in-law Meer Cossim; who being an enemy to the British government altogether, a war followed, terminating in his expulsion. This was followed by the invasion of Sujah Dowlah, and by scenes of horrid barbarity and devastation; when in 1765 Lord Clive took upon him the office of dewan, or minister who superintends the lands and collections of the revenue. An account of his proceedings has already been given; but whatever applause he might gain, and in some respects deservedly at the time, it is now said with some probability, that he raised the expectations of the people of England by far too high. The seeds of the succeeding evils were already sown. Many sources of wealth were dried up. Raw silk, cloths, and other manufactures, had formerly been exported to Guzerat, Lahore, and even Ispahan. This had ceased on the invasion of Nadir Shah; and the influx of wealth from the European nations had ceased before the British government in Bengal had an existence. It was computed that Cossim Aly Cawn robbed the country of near five millions sterling in jewels and specie. China, Madras, and Bombay, were supplied from Bengal to the amount of more than two millions; and several other circumstances besides these contributed to diminish the riches and opulence of the country. In the mean time the internal administration of the country had been extremely defective. The zemindars being under very little restraint, acted in a very arbitrary manner within their own districts; and the tenants had no redress against the impositions and exactions which were laid upon them. Meer Cossim appointed *aumils* to the collection of the revenues rather than zemindars. The *aumils* derive their authority directly from the person who has the command of the country for the present time, and consequently are more easily called to an account than the zemindars. At last, however, these *aumils*, having obtained too great an influence in the country, Lord Clive thought proper to change the plan of collection. Three natives were now appointed, in the nabob's name, to superintend this department; and one English gentleman, through whom the business was transacted, had his residence at the nabob's court, and communicated the intelligence to Calcutta. The principal acting minister in this plan, however, thought proper to change the mode of collection once more, and to re-appoint the *aumils*; in consequence of which the revenue became greatly diminished, and they were besides complained of as greatly oppressing the people. To remedy these evils, it was first proposed by Mr Verelst, to send some of the company's servants into the internal parts of the country with the title of supervisors: but the defects of administration were now beyond their power to remedy; the revenue was not only greatly diminished, but the expence of government exceedingly augmented; and in the year 1771 the company were alarmed by accounts that bills had been drawn upon them to the amount of 1,200,000*l*. At this time Mr Hastings was appointed to be governor of Bengal; and the confused state in which matters were at the commencement of his administration will easily appear from the following extract of a letter from the government of Bengal, dated in the month of November 1772.—"Every zemindary was left to its own particular customs. The articles which

Hindustan. which composed the revenue, the form of keeping the accounts, the computation of time, even the technical terms, which ever form the greatest obscurity in every science, differed as much as the soil and productions of the province. The nabobs exacted what they could from the zemindars and great farmers of the revenue, whom they left at liberty to plunder all below, reserving to themselves the liberty of plundering them in their turn, when they were supposed to have enriched themselves with the spoils of the country. The musaddis, who stood between the nabob and zemindars, and between them and the people, had each their shares of the public wealth. These profits were considered as illegal embezzlements, and therefore were taken with every precaution which could ensure secrecy; and being, consequently, fixed by no rule, depended on the temper, abilities, or power, of each individual for the amount. It therefore became a duty to every man to take the most effectual measures to conceal the value of his property, and evade every inquiry into his conduct; while the zemindars and other landholders, who had the advantage of long possession, availed themselves of it by complex divisions of the lands, and intricate modes of collection, to perplex the officers of government, and confine the knowledge of the rents to themselves. The internal management of each district varied no less than that of the whole province. The lands subject to the same collection, and intermixed with each other, were some held by farm, some superintended by shickdors or agents on the part of the collector, and were left to the zemindars themselves, under various degrees of controul." For some political reasons the company, though they had acquired the dewanny, had not yet chosen to assume the executive part of the office themselves, but committed it to the management of natives, as has already been mentioned, and their plans had been found extremely defective. By the time that Mr Hastings had been invested with the government, the court of directors had resolved to change their plan, and openly assume the office of the dewanny; and the rules established by that gentleman for the collection of the revenues, his mode of administering justice, and his police for the government of the country, are still observed with very little variation.

The plan for collecting the revenues consisted, in the first place, in rendering the accounts as simple and intelligible as possible; in the next, in establishing fixed rules for the collection; and in the third, making the mode of them uniform in all parts of the provinces; and in the fourth, providing for the equal administration of justice. The power of the zemindars was now circumscribed, and their extortions thoroughly put a stop to; many vexatious taxes and tolls were abolished, and a new mode of collecting the customs was established, to the great relief of the merchants: and so well were all the parts of this plan found to be adapted to the purposes they were designed to answer, that it has hitherto been made the model of all subsequent regulations.

One great objection to the India government is, that the English law, which undoubtedly is better calculated than any other for securing the liberties of the people, has not yet been adopted in India; whence it is thought that the company's servants have still show-

ed a disposition to oppress, rather than to relieve, the Hindostan. But in answer to that it is said, that the difference betwixt the two countries is so great, that there can be no comparison betwixt the one and the other, nor can the constitution of England be in any degree adapted to that of the other. The religion, laws, manners, and customs, of both Hindoos and Mohammedans, are so essentially different from those of this country, that it is impossible to assimilate them, should ever any thing of the kind be attempted. The only true method therefore of judging whether the present state of Hindostan is preferable to what it formerly was, is to compare it with what it was under the best Mogul emperors; and in this comparison it must certainly appear that the preference is greatly in favour of the British administration. In Major Rennel's work we are informed, that during the reign of Ackbar, whom he styles "the glory of the house of Timur," the country had never enjoyed so much tranquillity; "but this tranquillity would hardly be deemed such in any other quarter of the world, and must therefore be understood to mean a state short of actual rebellion, or at least commotion." The same author, speaking of the state of the British empire there, uses the following words: "The Bengal provinces which have been in our actual possession near 23 years, have, during that whole period, enjoyed a greater share of tranquillity than any other part of India, or indeed than those provinces had ever experienced since the days of Aureng-zeb." To this we may add, that the provinces have not only experienced a perfect freedom from external invasions, but likewise enjoy a degree of internal tranquillity altogether unknown before, by the subjection and civilization of a set of banditti who inhabited the hills of Rajemahl, and infested the travellers who passed that way; a wandering tribe of religious mendicants, who were wont to commit the greatest enormities.

Another advantage which the inhabitants of this country reap from the British government, is the security from violence and oppression either by their Mohammedan superiors or by one another. Under the article HINDOO we have already mentioned the particular circumstance that these people are liable to the punishment of losing their cast from a variety of causes, and that this is looked upon by them to be the most grievous calamity they can suffer. The Mohammedan governors frequently took advantage of their superstition in this respect to oppress them; and this circumstance alone frequently produced the most horrid confusion. In the instructions given to the supervisors, Mr Verelst informs them, that "it is difficult to determine whether the original customs, or the degenerate manners of the Mussulmans, have most contributed to confound the principles of right and wrong of these provinces. Certain it is (adds he), that almost every decision of theirs is a corrupt bargain with the highest bidder. Compensation was frequently accepted of even for capital crimes, and fines became at last an intolerable grievance; nay so venal were the judges at that time, that it became at last a settled rule to allow each of them a fourth part of any property in dispute as a compensation for his trouble.—It is impossible to suppose that such monstrous abuses continue under the British government: on the contrary we must readily believe,

Hindostan. believe, what the governors themselves assert, that immediately after the provinces fell under British jurisdiction, both Hindoos and Mohammedans have been left to the free exercise of their religion, laws, and customs. The Hindoos themselves acknowledge this, and are as well pleased with the mildness of the British government, as they are displeas'd with the superstition and cruelty of the Mohammedans. Under the British government we cannot suppose but that commerce, to which the inhabitants of this country are so much addicted, will be much more encouraged than by the avaricious and barbarous Mohammedans. The latter had imposed so many restraints upon trade of all kinds, by the multitude of taxes collected at the landing-places, watch-houses, markets, &c. that it was almost impossible to carry it on with any advantage. Among other salutary regulations, however, enacted by the British government in 1772, many of those taxes upon commerce were abolished, and a plan laid for effectually liberating the inhabitants from those shackles by which their commerce had been so long fettered.—Regard has also been paid to the instruction of the people in useful knowledge; and the seminary established at Calcutta by Sir William Jones, certainly does much honour to the founder. Some regard had indeed been paid to this by the Mohammedan emperors; but at the time that the British government commenced, these had been entirely neglected, their endowments resumed by government, and even the buildings fallen into ruin."

From a comparison of any government to which the Hindoos have hitherto been subject, with that of Britain, indeed, it is evident that the preference must be given greatly in favour of the latter. At the time when the British first visited that country, they were not under the jurisdiction of their native sovereigns, nor had they been so for a long time before. The Moguls were not only foreigners, but a most cruel and detestable race of men; and it was by usurpations of their own rebellious subjects that the anarchy and confusion was introduced, in which the country was involved for so long a time. The British are foreigners as well as the Moguls; but the latter, who profess the intolerant superstition of Mohammed, suffer their conduct to be influenced by it in such a manner as to treat the natives with the utmost cruelty. The greatest evil perhaps which results from the British government is, the exportation of great sums of money to a foreign country; but this evil, with respect to the provinces possessed by the British, existed also under the Mohammedan government. The Mogul emperors resided at Delhi, which is far distant from the provinces of Bengal, Bahar, and Orissa, the territories now possessed by Britain; so that the greatest part of the treasure sent to that capital was totally lost to them. In the time of Aureng-zebe, the emperor's tribute amounted to three millions sterling; and of this a considerable part was specie; but since that time the tribute was fixed at only 1,250,000l. and even this was a vast sum; to which if we add that carried out of the country by commanders of mercenary troops, who were all foreigners, it is not unreasonable to suppose that under the Mogul government matters were still worse, even in this respect, than under that of Britain.

We shall conclude this apology for the British go-
VOL. X. Part II. †

government, with the following extract from the treatise **Hindostan.** lately quoted, A short Review of the British Government in India. "A more detestable or detested race of people never appeared than the Mohammedan conquerors of India; whether we consider the brutality of their passions, the bigotry of their religion, the corruption of their manners, the barbarity of their education, or the tyranny of their government: In all these respects they were the terror and abhorrence of the Hindoos whose country they invaded, and whose dominion they usurped.

"The fanatic ignorance of the savage caliph, which dictated his barbarous reason for destroying the Alexandrian library, had neither been tutored nor refined by the Tartar education of Timur and his predecessors. The same superstitious bigotry which incited the Arabian caliphs to destroy the monuments of western learning, likewise impelled the Tartar khans to overthrow the religious temples of the eastern worship. At the commencement of the 11th century Mahmood entered Hindostan, and in the course of 12 expeditions he destroyed the famous temples of Nagracut, Tannasar, Matra, and Sumnaut. In the latter end of the next century, Mahmood Gori penetrated as far as the city of Benares, and committed outrages as Mahmood had done before at Nagracut and Sumnaut. Tamerlane possessed as much of this furious zeal as any of his savage predecessors; and if the enthusiasm of this destructive religion had not occasionally abated among some of his successors, they would scarce have left a Hindoo temple or priest in the country they subdued.

"Enough, however, had been done to fix an indelible stain on the memory of those intolerant tyrants, and to make a lasting impression on the minds of the Hindoos, who, to the latest period of the Mogul government, were kept in constant dread of doctrines, which, to their apprehensions, seemed to inspire the Mohammedans with sacrilegious cruelty. Idolatry is as great an abomination to a Mussulman as it was to the Jews when they most strictly revered the divine command which prohibits it; and most of the Hindoo ceremonies being considered by the Mohammedans as acts of idolatry, and all their pagodas as temples of idols, a religious principle excited mutual sentiments of abhorrence and antipathy between the conquerors and their subjects. The rest of the character of the Mohammedans may be summed up in the concise and emphatic words of Mr Scrafton, who says, 'their distinguishing qualities are perfidy and sensuality.'

"But notwithstanding these facts, and that the history of their government is a disgusting repetition of oppression, massacres, and rebellion, the fashion of the times has been to praise it, and to represent the situation of the Hindoos as easy and happy under it, till they were disturbed in this peaceful state of repose and security by the English; who have been described (with unparalleled injustice) as a set of rapacious taskmasters. It surely requires a very small degree of reflection to perceive, that such representations of the two governments must, from the very nature of things, be false.

"The Mohammedan conquerors came into India from a barbarous region, with minds and manners as uncultivated as the wilds from which they issued. The only notion they had of government was absolute power

Hindostan. in the sovereign, and absolute submission in the subject. The tenets of their religion, so far from softening the ferocity of their nature, served only to whet the edge of their persecution towards the suffering Hindoos, whom they harassed without mercy, and destroyed without remorse. The British conquerors came from a country famed for arts and sciences; the generous principles of public liberty had been instilled into their minds from their earliest infancy: the mild tenets of Christianity cherished and commanded every charitable duty: and they had been taught, by precept and example, to rule with equity, and to obey with freedom. Can it be supposed that under these circumstances, the two nations should have totally changed characters on their coming into India? That the barbarous and ferocious Tartar should become mild and enlightened; that the cultivated and generous Briton should have degenerated into a cruel tyrant; and that the British governors should have rendered the situation of their Hindoo subjects worse than it was under the Mogul emperors? Reason revolts at the idea; and nothing but the rankest prejudice could ever suggest or adopt it."

With regard to the geography of this country, Mr Rennel observes, that though by the modern Europeans, Hindostan has been understood to mean the tract situated between the rivers Indus and Ganges on the east and west, the mountains of Thibet and Tartary on the north, and the ocean on the south, the extent of Hindostan, properly so called, is much more circumscribed; and the name ought only to be applied to that part which lies to the northward of 21° or 22° latitude. The reputed southern boundary of Hindostan is the Nerbudda river as far as it goes, and the northern frontiers of Bengal and Bahar compose the remainder. The countries to the south of this line are called *Deccan* by the Indian geographers, and comprehend about one half of the territory generally known by the name of the *Mogul Empire*. Our author therefore chooses to distinguish the northern part by the name of *Hindostan Proper*; which has indeed the Indus and mountains of Thibet and Tartary for its western and northern boundaries; but the Burrampooter river is rather to be considered as the eastern boundary than the Ganges; the latter intersecting some of the richest provinces in the empire. According to this supposition, Hindostan Proper will equal in size the countries of France, Germany, Bohemia, Hungary, Switzerland, Italy, and the Low Countries; the Deccan and peninsula being about equal to the British islands, Spain, and Turkey in Europe.

Towards the north, Hindostan is very cold and barren; but towards the south, very hot, and fertile in corn, rice, fruits, and other vegetables. The northern provinces are very mountainous and sandy; while the southern are for the most part level, and well watered with several rivers.

The most remarkable mountains are those which surround it on three sides. Those on the west, separating it from Persia, called, in general, *Soleyman Kây*, or *the mountains of Soleyman*, are of a vast height as well as breadth, and are only passable in certain places, through which roads have been made for the sake of commerce. The chief are those which lead to Cabul, Gazna, and Candabar. This great chain of mountains is inhabited by different nations, the principal of which

are the Afghans, or Patans, and the Baluchas, who **Hindostan.** have extended themselves on the side of India, as well as Persia. The mountains on the north are called *Nagrakut*, *Hima*, or *Más Tâg*, which has an affinity with *Imaüs*, and by other names, which are given also in common to the mountains on each side, separating Hindostan from Thibet. The very prospect of these mountains is frightful, being nothing but hideous precipices, perpetually covered with snow, and not to be crossed without the greatest danger and difficulty.

The most remarkable rivers of Hindostan are the Indus and Ganges. The former is called by the orientals, *Send*, *Sind*, or *Sindi*. It rises in the mountains to the north or north-east of Hindostan; whence, after a long course, first to the south and then to the south-west, it falls into the Persian sea, below Lower Bander, by several mouths. In its course it receives several other large rivers, as the Nilâh, Jamal, Behat, and Lakka.

The Ganges, called in the Indies *Ganga*, rises in the kingdom of Thibet: entering Hindostan about the 30th degree of latitude, it runs first south-eastward by the cities of Bekâner, Minapor, Halabas, Benârea, and Patna, to Rajah Mabl, where it divides into two branches. The eastern having passed by Dâkka, the capital of Bengal, enters the gulf of that name about Chatigan. The western, descending by Kossum-Bazar and Hughly, falls into the gulf below Chandernagor towards Pipeli.

Many of the Jews and ancient Christians believed this river to be the Pison, one of the four mentioned in Scripture as the boundaries of the terrestrial paradise. The Indians retain the greatest reverence for its waters, going in crowds from the remotest parts of the country to wash in them, from a persuasion that they deface from all the spots of sin. The reason of this is, because they imagine this river does not take its source from the bosom of the earth, but descends from heaven into the paradise of Devendre, and from thence into Hindostan. Nothing is more childish than the fables of the Bramins on this subject, yet the people swallow them all. The Mogul and prince of Golconda drink no other water than that of the Ganges: foreigners, on the contrary, pretend that it is very unwholesome, and that it cannot be safely drank till it is first boiled. There is a great number of superb pagodas on the banks of the Ganges, which are immensely rich. At certain festivals, there has been sometimes a concourse of 100,000 people who came to bathe in it. But what principally distinguishes this river, besides its greatness and rapidity, is the gold it brings down in its sands and throws on its banks; and the precious stones and pearls it produces, not only in itself, but in the gulf of Bengal, into which it discharges its waters, and which abounds therewith. The Chun or Jemma, the Guderasu, the Persilis, Lakia, and several other rivers, discharge themselves into it during its course.

The weather and seasons are, for the general, very regular in this spacious country; the winds blowing constantly for six months from the south, and six from the north, with very little variation. The months of April, May, and the beginning of June, till the rains fall, are so extremely hot, that the reflection from the ground is apt to blister one's face; and but for the breeze or small gale of wind which blows every day, there

Hindostan. there would be no living in that country for people bred in northern climates; for excepting in the rainy season, the coldest day is hotter there at noon than the hottest day in England. However, very surprising changes of heat and cold sometimes happen within a few hours; so that a stifling hot day is succeeded by a night cold enough to produce a thin ice on the water, and that night by a noon as scorching as the preceding. Sometimes, in the dry season, before the rains, the winds blow with such extreme violence, that they carry vast quantities of dust and sand into the air, which appear black like clouds charged with rain; but fall down in dry showers, filling the eyes, ears, and nostrils of those among whom they descend, and penetrate every chest, cabinet, or cupboard, in the houses or tents, by the key-hole or crevices.

From Surat to Agra, and beyond, it seldom or never rains, excepting in one season of the year: that is, from the middle of June to the middle of September. These rains generally begin and end with most furious storms of thunder and lightning. During these three months it rains usually every day, and sometimes for a week together without intermission: by these means the land is enriched, like Egypt by the Nile. Although the land looks before like the barren sands of the Arabian deserts; yet, in a few days after those showers begin to fall, the surface appears covered with verdure. When the rainy season is over, the sky becomes perfectly serene again, and scarce one cloud appears all the other nine months: however, a refreshing dew falls every night during that dry interval, which cools the air, and cherishes the earth.

The produce of Hindostan is very rich in every kind, whether it be fossil, vegetable, or animal. Besides other precious stones found in it, there is a diamond-mine at the town of Soumelpâr in Bengal. Quarries of Theban stone are so plentiful in the Mogul's empire, that there are both mosques and pagods built entirely of it. Some travellers tell us, there are mines of lead, iron, and copper, and even silver; but those of the last, if there be any, need not be opened, since the bullion of all nations is sunk in this empire, which will take nothing else in exchange for her commodities, and prohibits the exporting it again. They till the ground with oxen and foot-ploughs, sowing in May and the beginning of June, that all may be over before the rains, and reaping in November and December, which with them are the most temperate months in the year. The land is nowhere inclosed, excepting a little near towns and villages. The grass is never mowed to make hay, but cut off the ground, either green or withered, as they have occasion to use it. Wheat, rice, barley, and other grain, grow here in plenty, and are very good. The country abounds no less in fruits, as pomegranates, citrons, dates, grapes, almonds, and coconuts; plums, those especially called *mirabolans*; plantains, which in shape resemble a slender cucumber, and in taste excel a Norwich pear; mangos, an excellent fruit, resembling an apricot, but larger; ananas or pine-apples; lemons and oranges, but not so good as in other countries; variety of pears and apples in the northern parts; and the tamarind-tree, the fruit of which is contained in a pod resembling those of beans. There are many other kinds of fruit-trees peculiar to the country. But the valuable trees are the cotton and

mulberry, on account of the wealth they bring the natives from the manufactures of calicoes and silks. They plant abundance of sugar-canes here, as well as tobacco; but the latter is not so rich and strong as that of America, for want of knowing how to cure and order it.

Hindostan affords also plenty of ginger, together with carrots, potatoes, onions, garlic, and other roots known to us, besides small roots and herbs for salads; but their flowers, though beautiful to look at, have no scent, excepting roses, and some few other kinds.

There is a great variety of animals in this country, both wild and tame; of the former are elephants, rhinoceroses, lions, tygers, leopards, wolves, jackals, and the like. The jackals dig up and eat dead bodies, and make a hideous noise in the night. The rhinoceros is not common in the Mogul's empire; but elephants are very numerous, some 12, 14, or 15 feet high. There is plenty of venison and game of several kinds; as red-deer, fallow-deer, elks, antelopes, kids, hares, and such like. None of these are imparked, but all in common, and may be any body's who will be at the pains to take them. Among the wild animals also may be reckoned the musk-animal, apes, and monkeys.

Hindostan affords variety of beasts for carriage, as camels, dromedaries, mules, asses, horses, oxen, and buffaloes. Most of the horses are white, and many curiously dappled, pied, and spotted all over. The flesh of the oxen is very sweet and tender. Being very tame, many use them as they do horses to ride on. Instead of a bit, they put one or two small strings through the gristle of the nostrils, and fastening the ends to a rope, use it instead of a bridle, which is held up by a bunch of gristly flesh which he has on the fore-part of his back. They saddleshim as they do a horse; and, if spurred a little, he will go as fast. These are generally made use of all over the Indies; and with them only are drawn waggons, coaches, and chariots. Some of these oxen will travel 15 leagues in a day. They are of two sorts; one six feet high, which are rare; another called *dwarfs*, which are only three. In some places, where the roads are stony, they shoe their oxen when they have to travel far. The buffalo's skin makes excellent buff, and the female yields very good milk; but their flesh is neither so palatable nor wholesome as beef. The sheep of Hindostan have large heavy tails, and their flesh is good, but their wool coarse.

This country is much infested with reptiles and insects; some of a noxious kind, as scorpions, snakes, and rats; but the lizards, which are of a green colour, are not hurtful. Snakes and serpents, we are told, are sometimes employed to despatch criminals, especially such as have been guilty of some atrocious crime, that kind of death being attended with the most grievous torture. The most troublesome insects in this hot country are flies, musketoes, and chinchies, or bugs, the first by day, and the others in the night; when they offend no less by their stench than their bite. See INDIA, SUPPLEMENT.

HINE, or HIND, a husbandman's servant. Thus the person who oversees the rest, is called the master's hinc.

HINNOM, or the Valley of HINNOM, in *Ancient Geography*, a place that lay to the south of Jerusalem.

Hinnon,
Hinzuan.

It was also called *the valley of Tophet*, and was remarkable for the cruel and barbarous worship of the god Moloch, where parents made their children pass through the fire in honour of that idol.

HINZUAN, one of the Comora islands, lying between Madagascar and the continent of Africa, otherwise called Anzuame, Anjuan, Juanny, and Johanna. As the accounts given of it by the abbé Raynal and Major Rooke seem to contradict each other, we shall lay before our readers the substance of Sir William Jones's description of it, by whom the island was visited, and whose regard to veracity will not be controverted.

It resembles a vast amphitheatre, of which a general notion may be formed, by conceiving in the mind a multitude of hills infinitely diversified in figure and in magnitude, thrown together with artless symmetry in all conceivable positions. A series of mountains forms the back ground, one of which is pointed, almost half a mile above the level of the sea, and not more than three miles from the shore. The whole of them are richly clothed with fruit trees of exquisite verdure. Beyond this range is another tier, partly barren and partly verdant. Nearer the shore there is a vast multitude of cliffs, which bring their verdure almost to the water-side. The rows of palm trees with which it abounds, which give an enchanting beauty and variety to the scene, almost appear to have been planted by design.

The north side of the island shoots out into two points, which are 26 miles distant from each other, with a large bay between them. It is justly considered as a proper place of refreshment for vessels bound to and from the East Indies, as it yields limes, lemons, oranges, and many other valuable antiscorbutics. The town which is the king's residence, is on the east side of the island, which contains no more than about 200 houses, notwithstanding it is three-fourths of a mile in length.

The cattle of this island are a sort of buffaloes, with a large hump on their shoulders, which is reported to be most delicious eating; but there are no horses, asses, or mules in the island. The original natives may be about 7000, who occupy the hills, and carry on desultory wars with the Arabian interlopers living on the sea coast, and about 3000 in number. The expences of government are defrayed by a tax on 200 villages, but the three principal towns are exempted. The kingly power is considered as elective by the principles of the constitution; but the line of succession has not been altered since the first election of a sultan.

The price of every article is under proper regulations, and ships who touch here can be plentifully supplied with bullocks, goats, and fowls. The people seem to be extravagantly fond of titles, and therefore lords, dukes, and princes, are common among them. A duke will dispose, in person, of the product of his own estate, which men of a similar rank in Europe will only do by the intervention of agents. The natives are said to be indolent, as is the case in most tropical countries, and neglect the cultivation of that exuberant soil which Providence has bestowed upon them.

There is a sacred lake, about half a mile in circumference, in the interior parts of the island, about fifteen miles from the town of Johanna. The wild ducks frequenting this sequestered spot are said to be worshipped by the natives, and consulted as oracles in all affairs of

importance. These people countenance polygamy, and the keeping of concubines. The men are extremely jealous, and never admit strangers of their own sex to see the women.

The chewing the betel nut prevails greatly in Hinzuan, as in most eastern countries, and corresponds to the European custom of smoking tobacco or taking snuff, only with this difference, that the practice is still more general. They are very abstemious as to the use of wine, that article being prohibited by the religion of Mahomet, and perform the duty of prayer three or four times a-day. *E. Long. 44. 15. S. Lat. 12. 30.*

HIP, in the *Materia Medica*, the fruit of the dog-rose or wild brier. See **ROSA**, **BOTANY Index**.—This fruit contains a sourish sweetish pulp; with a rough prickly matter inclosing the seeds, from which the pulp ought to be carefully separated before it be taken internally: the Wirtemberg college observes, that from a neglect of this caution, the pulp of hips sometimes occasions a pruritus and uneasiness about the anus; and the conserve of it has been known to excite violent vomiting. The conserve is the only officinal preparation of this fruit.

HIPPARCHUS, a great astronomer, born at Nice in Bithynia, flourished between the 154th and 163d Olympiads. His commentary upon Aratus's *Phænomena* is still extant. Robault was very much mistaken when he asserted, that this astronomer was not acquainted with the particular motion of the fixed stars from west to east, by which their longitude changes. By foretelling eclipses, he taught mankind not to be frightened at them, and that even the gods were bound by laws. Pliny, who tells this, admires him for making a review of all the stars; by which his descendants would be enabled to discover whether they are born and die, whether they change their place, and whether they increase and decrease.

HIPPIA, a genus of plants belonging to the syngonessia class. See **BOTANY Index**.

HIPPOBOSCA, or **HORSE-FLY**, a genus of insects, belonging to the order of diptera. See **ENTOMOLOGY Index**.

HIPPOCAMPUS, or **SEA-HORSE**, a species of fish belonging to the genus syngnathus. See **SYNGNATHUS**, **ICHTHYOLOGY Index**.

HIPPOCASTANUM, or **COMMON HORSE-CHESNUT**. See **ÆSCULUS**, **BOTANY Index**.—It may be here added, that from several experiments in the French *Memoires d'Agriculture*, it appears that the fruit of the horse-chesnut affords a wholesome nourishment for cattle, and may even be employed with success for fattening them. It is said to render the tallow of those fattened with it particularly firm. The milk yielded by cows fed upon it, is also said to be thicker and richer than that produced from any other kind of food.—The fruit of this tree has been likewise used as food for sheep and poultry, and as soap for washing. It was much employed in powder as a sternutatory by an itinerant oculist, and has been recommended by some others in certain states of ophthalmia, headach, &c. in which errhines are indicated. Its effects as a sternutatory may also be obtained by using it under the form of infusion or decoction drawn up into the nostrils. And it is entirely with a view to its errhine power that it is now introduced into the pharmacopæia of the Edinburgh college.

Hinnon
Hippocastanum.

hippocastanum
H
hippocrates.

lege. But besides this, the bark has also been represented by some as a cure for intermittent fevers; and it is probably with this intention that this part of the hippocastanum is introduced as an officinal article in the *Pharmacopœia Rossica*.

HIPPOCENTAUR, (formed of *ἵππος*, "horse," *κέντρον*, *pungo*, "I spur," and *βους*, "bull"), in antiquity, a fabulous monster, supposed to be half horse and half man.

What gave occasion to the fable was, that a people of Thessaly, inhabiting near Mount Pelion, became thus denominated, because they were the first that taught the art of mounting on horseback; which occasioned some of their neighbours to imagine, that the horse and man made but one animal.

The hippocentaurs should seem to have differed from the centaurs, in this, that the latter only rode on bullocks, and the former on horses, as the names themselves intimate.

HIPPOCRAS, a medicinal drink, composed of wine, with spices and other ingredients infused therein; much used among the French by way of a cordial dram after meals.

There are various kinds of hippocras, according to the kind of wine and the other additional ingredients made use of; as white hippocras, red hippocras, claret-hippocras, strawberry hippocras, hippocras without wine, cyder hippocras, &c.

That directed in the late London Dispensary, is to be made of cloves, ginger, cinnamon, and nutmegs, beat and infused in canary with sugar; to the infusion, milk, a lemon, and some slips of rosemary, are to be put, and the whole strained through a flannel. It is recommended as a cordial, and as good in paralytic and all nervous cases.

HIPPOCRATIA, a genus of plants belonging to the triandria class; and in the natural method ranking with those of which the order is doubtful. See *BOTANY Index*.

HIPPOCRATES, the greatest physician of antiquity, was born in the island of Cos in the 80th Olympiad, and flourished at the time of the Peloponnesian war. He was the first that we know of who laid down precepts concerning physic; and, if we may believe the author of his life, who goes under the name of *Soranus*, drew his original from Hercules and *Æsculapius*. He was first a pupil of his own father Heraclides, then of Herodicus, then of Gorgias of Leontinum the orator, and, according to some, of Democritus of Abdera. After being instructed in physic, and in the liberal arts, and losing his parents, he left his own country, and practised physic all over Greece; where he was so much admired for his skill, that he was publicly sent for with Euseyphon, a man superior to him in years, to Perdiccas king of Macedonia, who was then thought to be consumptive. But Hippocrates, as soon as he arrived, pronounced the disease to be entirely mental, as in truth it was. For upon the death of his father Alexander, Perdiccas fell in love with Philas, his father's mistress: and this Hippocrates discerning by the great change her presence always wrought upon him, a cure was soon effected.

Being intrusted by the people of Abdera to come and cure Democritus of a supposed madness, he went; but, upon his arrival, instead of finding Democritus mad,

he found all his fellow citizens so, and Democritus the only wise man among them. He heard many lectures, and learned much philosophy from him; which has made Cornelius Celsus and some others imagine, that Hippocrates was the disciple of Democritus, though it is probable they never saw each other till this interview which was occasioned by the Abderites. Hippocrates had also public invitations to other countries. Thus, when a plague invaded the Illyrians and Pæonians, the kings of those countries begged him to come to their relief: he did not go; but learning from the messengers the course of the winds there, he concluded that the distemper would come to Athens; and foretelling what would happen, applied himself to take care of the city and the students. He was indeed such a lover of Greece, that when his fame had reached as far as Persia, and upon that account Artaxerxes had intreated him by his governor of the Hellespont, with a promise of great rewards, to come to him, he refused to go. He also delivered his own country from a war with the Athenians, that was just ready to break out, by prevailing with the Thessalians to come to their assistance, for which he received very great honours from the Coans. The Athenians also conferred great honours upon him: they admitted him next to Hercules in the Eleusinian ceremonies; gave him the freedom of the city; and voted a public maintenance for him and his family in the prytaneum or council-house at Athens, where none were maintained at the public charge, but such as had done public service to the state. He died among the Larissæans, some say in his 90th year, some in his 85th, others in his 104th, and some in his 109th. The best edition of his works is that of Foesius in Greek and Latin. Hippocrates wrote in the Ionian dialect. His aphorisms, prognostics, and all that he has written on the symptoms of diseases, justly pass for masterpieces. See *History of MEDICINE*.

HIPPOCRENE, in *Ancient Geography*, a fountain of Mount Helicon, on the borders of Bœotia, sacred to the muses. Some, as Ovid, make Hippocrene and Aganippe the same. See *AGANIPPE*.

HIPPOCREPIS, COMMON HORSE-SHOE VETCH, a genus of plants belonging to the diadelphia class; and in the natural method ranking under the 32d order, *Papilionacea*. See *BOTANY Index*.

HIPPODROME, **HIPPODROMUS** (composed of *ἵππος*, "horse" and *δρομος*, "course," of the verb *δρομαίω*, *curro*, "I run"), in antiquity, a list or course wherein chariot and horse races were performed, and horses exercised.

The Olympian hippodrome or horse-course was a space of ground of 600 paces long, surrounded with a wall, near the city Elis, and on the banks of the river Alpheus. It was uneven, and in some degree irregular, on account of the situation; in one part was a hill of a moderate height, and the circuit was adorned with temples, altars, and other embellishments. See *STADIUM*. There is a very famous hippodrome at Constantinople, which was begun by Alexander Severus, and finished by Constantine. This circus, called by the Turks *atmeican*, is 400 paces long, and above 100 paces wide. At the entrance of the hippodrome there is a pyramidal obelisk of granite in one piece, about 50 feet high, terminating in a point, and charged with hieroglyphics. The Greek and Latin inscriptions

Hippocrates
H
Hippodrome.

Hippo-
dromic
||
Hippoma-
nes.

tions on its base show, that it was erected by Theodosius; the machines that were employed to raise it are represented upon it in basso-relievo. We have some vestiges in England of the hippodromus, in which the ancient inhabitants of this country performed their races; the most remarkable is that near Stonehenge, which is a long tract of ground, about 350 feet or 200 druid cubits wide, and more than a mile and three quarters, or 6000 druid cubits, in length, inclosed quite round with a bank of earth, extending directly east and west. The goal and career are at the east end. The goal is a high bank of earth, raised with a slope inwards, on which the judges are supposed to have sat. The metæ are two tumuli, or small barrows, at the west end of the course. These hippodromes were called in the language of the country *rhedagua*, the racer *rhedagur*, and the carriage *rheda*, from the British word *rhedeg*, "to run." One of these hippodromes, about half a mile to the southward of Leicester, retains evident traces of the old name *rhedagua*, in the corrupted one of *rawdikes*. There is another of these, says Dr Stukeley, near Dorchester; another on the banks of the river Lowther, near Penrith in Cumberland; and another in the valley, just without the town of Royston.

HIPPOGLOSSUS, a species of fish belonging to the genus *PLEURONCTES*, which see in *ICHTHYOLOGY Index*.

HIPPOLYTUS, a son of Theseus and Hippolyte, famous in fabulous history for his virtue and his misfortunes. His stepmother Phædra fell in love with him, and when he refused to pollute his father's bed, she accused him to Theseus of offering violence to her person. Her accusation was readily believed, and Theseus intreated Neptune to punish the incontinence of his son. Hippolitus fled from the resentment of his father; and as he pursued his way along the sea shores, his horses were so frightened at the noise of sea calves which Neptune had purposely sent there, that they ran among the rocks till his chariot was broken and his body torn to pieces. Temples were raised to his memory, particularly at Trœzene, where he received divine honours. According to some accounts, Diana restored him life.

HIPPOMANE, the *MANCHINEEL-TREE*; a genus of plants belonging to the monœcia class; and in the natural method ranking under the 38th order, *Tri-cocœ*. See *BOTANY Index*.

HIPPOMANES, a sort of poison, famous among the ancients as an ingredient in amorous philters or love-charms. The word is Greek *ιππομανης*, composed of *ιππος*, "a horse," and *μανη*, "fury or madness."

Authors are not agreed about the nature of the hippomanes. Pliny describes it as a blackish caruncle found on the head of a new-born colt; which the dam bites off and eats as soon as she is delivered. He adds, that if she be prevented herein by any one's cutting it off before, she will not take to, nor bring up the young. Virgil, and after him Servius and Columella, describe it as a poisonous matter trickling from the pendum of a mare when proud, or longing for the horse. At the end of Mr Bayle's dictionary is a very learned dissertation on the hippomanes, and all its virtues both real and pretended.

HIPPONAX, a Greek poet, born at Ephesus 540 years before the Christian era. He cultivated the same satirical poetry as Archilochus, and was not inferior to him in the beauty or vigour of his lines. His satirical raillery obliged him to fly from Ephesus. As he was naturally deformed, two brothers, Buphalus and Anthermus, made a statue of him; which, by the ugliness of its features, exposed the poet to universal ridicule. Hipponax resolved to revenge the injury; and he wrote such bitter invectives and satirical lampoons against them, that they hanged themselves in despair. (*Cic. ad Famil. vii. ep. 24.*)

HIPPOPHAE, *SEA-BUCKTHORN*; a genus of plants belonging to the diœcia class; and in the natural method ranking under the 16th order, *Calyciflora*. See *BOTANY Index*.

HIPPOPHAGI, in *Ancient Geography*, a people of Scythia, so called from their living on horse-flesh; the fare at this day of the Tartars their descendants. Also a people of Persia (Ptolemy).

HIPPOPODES, *HIPPOPEDES*, or *Hippopodia*, composed of *ιππος*, *horse*, and *πους*, *foot*, in the ancient geography, an appellation given to a certain people situated on the banks of the Scythian sea, as being supposed to have had horses feet. The hippopodes are mentioned by Dionysius, Geogr. v. 310. Mela, lib. iii. cap. 6. Pliny, lib. iv. cap. 13. and St Augustine, *De Civit. lib. xvi. cap. 8.* But it is conjectured, that they had this appellation given them on account of their swiftness or lightness of foot. Mr Pennant supposes them to have been the inhabitants of the Bothnian gulf, and that they were the same sort of people as the *Finni Lignipedes* of Olaus. They wore snow-shoes; which he thinks might fairly give the idea of their being, like horses, hoofed and shod.

HIPPOTAMUS, the *RIVER-HORSE*; a genus of quadrupeds belonging to the order of belluæ. See *MAMMALIA Index*.

HIPPURIS, *MARE'S-TAIL*, a genus of plants belonging to the monandria class; and in the natural method ranking under the 15th order, *Inundata*. See *BOTANY Index*.

HIRÆA, a genus of plants belonging to the decandria class. See *BOTANY Index*.

HIRAM, a king of Tyre, contemporary with Solomon, whom he supplied with cedar, gold, silver, and other materials for building the temple. He died 1000 years B. C.

HIRAM of Tyre, an artist who assisted in the construction of Solomon's temple, and other public buildings at Jerusalem, flourished 1015 B. C.

HIRCANIA, in *Ancient Geography*. See *HYRCANIA*.

HIRCH-HORN, a town of Germany, in the circle of the Lower Rhine, with a strong castle. It is seated on the side of a hill on the river Neckar, and belongs to Bavaria. E. Long. 9. 0. N. Lat. 49. 28.

HIRCUS, in *Astronomy*, a fixed star of the first magnitude, the same with Capella. It is also made use of by some writers for a comet, encompassed as it were with a mane, apparently rough and hairy.

HIRE, **PHILIP DE LA**, a French mathematician and astronomer of eminence, was born at Paris in the year 1640. His father, who was painter to his majesty, de-

signing

Hire signing to bring him up to the same occupation, taught him drawing and such parts of the mathematics as are intimately connected with it. At the age of 20 he took a journey into Italy, to enlarge his knowledge of his favourite art, in which country he resided for about four years. The study of the mathematics afterwards occupied all his attention, which he continued to prosecute on his return to his native city; and the publication of some works having procured him so high a reputation, he was chosen a member of the Academy of Sciences in the year 1678.

When the celebrated minister Colbert conceived the design of constructing a better map of France than any at that time to be met with, De la Hire was nominated in conjunction with Picard, to make the necessary observations, which engaged his attention for some years in different provinces. But besides the chief object of his journeys, he philosophized upon every thing that occurred to him, in a particular manner on the variations of the magnetic needle, on refractions, and the height of mountains as ascertained by the barometer.

In the year 1683 he was employed in continuing the meridian line which had been begun by Picard in 1669. He continued it from Paris towards the north, and Cassini carried it on towards the south; but on the death of Colbert, which happened the same year, the work was laid aside in an unfinished state. He was afterwards employed, in conjunction with other eminent philosophers, in taking the necessary levels for the grand aqueducts which Louis XIV was about to make.

The works which have been published by De la Hire are very numerous; and as he was professor of the Royal College and Academy of Architecture, he must have been constantly employed. He had the politeness, circumspection, and prudence of Italy, which made him appear too reserved in the estimation of his versatile countrymen, yet he was regarded by all as an honest, disinterested man. He died in the year 1718, at the great age of 78.

He published *Traité de Méchanique; Nouvelle Méthode en Géométrie pour les Sections des Surfaces Coniques et Cylindriques; De Cycloïde; Nouveaux Elémens des Sections Coniques; les Lieux Géométriques; La Construction ou Effection des Equations; La Gnomonique*, and several others of less importance. That which gained him the greatest reputation all over Europe, was his *Selectiones Conicæ in novem libros distributæ*, considered by the best judges as an original work.

HIRING, in Law. See *BORROWING and Hiring*.

HIRPINI, in *Ancient Geography*, a people of Italy, next to the Samnites, to the south-east, and descendants from them; situated to the north of the Picentini, and to the west of the Apuli, having on the north the Apennine and a part of Samnium. Their name is from *Hirpus*, a term denoting a wolf in their language; either because under the conduct of this animal the colony was led and settled, according to Strabo; or because, like that prowling animal, they lived on plunder, according to Servius.

HIRSBERG, a town of Silesia, in the territory of Jauer, famous for its mineral baths. It is seated on the river Bosar, in E. Long. 15. 50. N. Lat. 50. 43-

HIRSCHFELD, a town of Germany, in the circle

of the Upper Rhine, and capital of a principality of the same name, depending on a famous abbey which was secularized in favour of the house of Cassel. It is seated on the river Fulda, in E. Long. 9. 52. N. Lat. 51. 46.

HIRTELLA, a genus of plants belonging to the pentandria class; and in the natural method ranking with those of which the order is doubtful, See *BOTANY Index*.

HIRUDO, the LEECH; a genus of insects belonging to the order of vermes intestina. See *HELMINTHOLOGY Index*.

HIRUNDO, a genus of plants belonging to the order of passeræ. See *ORNITHOLOGY Index*.

HISPA, in *Zoology*, a genus of insects belonging to the order coleoptera. See *ENTOMOLOGY Index*.

HISPALIS, a town of Bætica, in the Farther Spain; an ancient mart or trading town on the Bætis, navigable quite up to it for ships of burthen, and thence to Corduba for river barges. Called *Colonia Romulensis*. It had also a conventus juridicus, a court of justice or assizes, (Pliny). Now called *Seville*. W. Long. 6. N. Lat. 37.

HISPANIA, called *Hesperia Ultima*, (Horace), because the westmost part of Europe; also *Iberia*, from the river Iberus. Its name *Hispania*, or *Spania*, (Greek) is of Phœnician original, from its great number of rabbits: the Phœnicians, who settled several colonies on the coast, calling it *Spanjah* from these animals. It has the sea on every side, except on that next to Gaul, from which it is separated by the Pyrenees. The Romans at first divided it into the Farther and Hither Spain, under two prætors. In that state it continued down to Augustus; who divided the Farther Spain into Bætica, which he left to the people to be governed by a proconsul; and into Lusitania, which he added to his own provinces; calling the Hither Spain *Tarraconensis*. Hispania was a country celebrated for its fertility, of which it has greatly fallen short in modern times. The people were of a warlike turn, (Strabo); and their bodies being formed for hardships and labour, they ever preferred war to peace, and were remarkably prodigal of life (Justin, Sil. Italicus). Spain has produced several great men, both in a literary and a political capacity. See *SPAIN*.

HISPANIOLA, called also **ST DOMINGO**, the largest of the Antilles or Caribbee islands, extending about 420 miles from east to west, and 120 in breadth from north to south; lying between 17° 37' and 20° of N. Lat. and between 67° 35' and 74° 15' W. Long. The climate is hot, but not reckoned unwholesome; and some of the inhabitants are said to arrive at the age of 120. It is sometimes refreshed by breezes and rains; and its salubrity is likewise in a great measure owing to the beautiful variety of hills and valleys, woods and rivers, which everywhere present themselves. It is indeed reckoned by far the finest and most pleasant island of the Antilles, as being the best accommodated to all the purposes of life when duly cultivated.

This island, famous for being the earliest settlement of the Spaniards in the New world, was at first in high estimation for the quantity of gold it supplied: this wealth diminished with the inhabitants of the country, whom they obliged to dig it out of the bowels of the earth;

Hispaniola. earth; and the source of it was entirely dried up, when they were exterminated, which was quickly done by a series of the most shocking barbarities that ever disgraced the history of any nation. Benzoni relates, that of two millions of inhabitants, contained in the island when discovered by Columbus in 1492, scarce 153 were alive in 1545. A vehement desire of opening again this source of wealth inspired the thought of getting slaves from Africa; but, besides that these were found unfit for the labours they were destined to, the multitude of mines, which then began to be wrought on the continent, made those of Hispaniola no longer of any importance. An idea now suggested itself, that their negroes, which were healthy, strong, and patient, might be usefully employed in husbandry; and they adopted, through necessity, a wise resolution, which, had they known their own interest, they would have embraced by choice.

The produce of their industry was at first extremely small, because the labourers were few. Charles V. who, like most sovereigns, preferred his favourites to every thing, had granted an exclusive right of the slave-trade to a Flemish nobleman, who made over his privilege to the Genoese. Those avaricious republicans conducted this infamous commerce as all monopolies are conducted; they resolved to sell dear, and they sold but few. When time and competition had fixed the natural and necessary price of slaves, the number of them increased. It may easily be imagined, that the Spaniards, who had been accustomed to treat the Indians as beasts, did not entertain a higher opinion of these negro Africans, whom they substituted in their place. Degraded still farther in their eyes by the price they had paid for them, even religion could not restrain them from aggravating the weight of their servitude. It became intolerable, and these wretched slaves made an effort to recover the unalienable rights of mankind. Their attempt proved unsuccessful; but they reaped this benefit from their despair, that they were afterwards treated with less inhumanity.

This moderation (if tyranny cramped by the apprehension of revolt can deserve that name) was attended with good consequences. Cultivation was pursued with some degree of success. Soon after the middle of the 16th century, the mother country drew annually from this colony ten millions weight of sugar, a large quantity of wood for dyeing, with tobacco, cocoa, cassia, ginger, and cotton, in abundance. One might imagine, that such favourable beginnings would give both the desire and the means of carrying them further; but a train of events, more fatal each than the other, ruined these hopes.

The first misfortune arose from the depopulation of the island. The Spanish conquests on the continent should naturally have contributed to promote the success of an island, which nature seemed to have formed to be the centre of that vast dominion arising around it, to be the staple of the different colonies. But it fell out quite otherwise: on a view of the immense fortunes raising in Mexico, and other parts, the richest inhabitants of Hispaniola began to despise their settlements, and quitted the true source of riches, which is on the surface of the earth, to go and ransack the

bowels of it for veins of gold, which are quickly exhausted. The government endeavoured in vain to put a stop to this emigration; the laws were always either artfully eluded, or openly violated.

The weakness, which was a necessary consequence of such a conduct, leaving the coasts without defence, encouraged the enemies of Spain to ravage them. Even the capital of this island was taken and pillaged by that celebrated English sailor, Sir Francis Drake. The cruizers of less consequence contented themselves with intercepting vessels in their passage through those latitudes, the best known at that time of any in the new world. To complete these misfortunes, the Castilians themselves commenced pirates. They attacked no ships but those of their own nation; which were more rich, worse provided, and worse defended, than any others. The custom they had of fitting out ships clandestinely, in order to procure slaves, prevented them from being known; and the assistance they purchased from the ships of war, commissioned to protect the trade, insured to them impunity.

The foreign trade of the colony was its only resource in this distress; and that was illicit: but as it continued to be carried on, notwithstanding the vigilance of the governors, or, perhaps, by their connivance, the policy of an exasperated and short-sighted court exerted itself in demolishing most of the sea-ports, and driving the miserable inhabitants into the inland country. This act of violence threw them into a state of dejection; which the incursions and settlement of the French on the island afterwards carried to the utmost pitch. The latter, after having made some unsuccessful attempts to settle on the island, had part of it yielded to them in 1697, and afterwards enjoyed by far the best share.

Spain, totally taken up with that vast empire which she had formed on the continent, used no pains to dissipate this lethargy. She even refused to listen to the solicitations of her Flemish subjects, who earnestly pressed that they might have permission to clear these fertile lands. Rather than run the risk of seeing them carry on a contraband trade on the coasts, she chose to bury in oblivion a settlement which had been of consequence, and was likely to become so again.

This colony, which had no longer any intercourse with the mother country but by a single ship of so great burthen, that arrived from thence every third year, consisted, in 1717, of 18,420 inhabitants, including Spaniards, mestees, negroes, or mulattoes. The complexion and character of these people differed according to the different proportions of American, European, and African blood they had received from that natural and transient union which restores all races and conditions to the same level. These demi-savages, plunged in the extreme of sloth, lived upon fruits and roots, dwelt in cottages without furniture, and most of them without clothes. The few among them, in whom indolence had not totally suppressed the sense of decency and taste for the conveniencies of life, purchased clothes of their neighbours the French in return for their cattle, and the money sent to them for the maintenance of two hundred soldiers, the priests, and the government.

In the year 1788, the revolutionary principles which began to agitate Europe, made their way to the West India.

Hispaniola. Indies. The French association for abolishing the slave trade, called *Amis des Noirs*, kept up a correspondence with such rich Mulattoes as had come to France for their education, and its members laboured to convince them that there was neither civil nor political distinction between them and the white people. These ideas were strengthened by the celebrated declaration of the national assembly, that all men are born and continue free, possessing equal rights. The consequence was, that the Mulattoes of Hispaniola broke out into open rebellion, but for want of unity of design they were soon overpowered.

This spirit, however, still continued to exert itself, and the assembly of France having avowed its design not to interfere with the internal affairs of the colony, discontent and remonstrances were exhibited by the factious friends of the negroes. They considered this as countenancing the African trade, and an acknowledgment that the planters were not colonists, but independent people. This idea struck the colonists themselves, for by a decree they debarred the king's delegate from having a negative on any of their future acts. The *Amis des Noirs*, in the mean time, exerted all their influence to kindle and cherish a spirit of rebellion in the minds of the people of colour; for which purpose they carefully taught one James Oge, then residing at Paris, the doctrines of equality and the rights of man, urged him to return to St Domingo, place himself at the head of his people, and rescue them from the oppression of the whites, pledging themselves to procure arms and ammunition for him in America, that the affair might be kept as profound a secret as possible. He accordingly set sail for New England in July 1790; but all the vigilance of the parties concerned could not deceive the government of France, and his portrait was sent to St Domingo before him. He made the island in October, and declared soon after by virtue of a manifesto, that if the privileges of the whites were not conferred on all without discrimination, he would instantly take up arms to obtain them by force. With a small detachment of 200 men he massacred all the white people that came in his way, as well as all those of his own colour who refused to join him. This little army was very soon subdued, and their misguided leader was punished as a traitor.

The French national assembly decreed that every person 25 years old and upwards, if he possessed property, and had lived two years in the colony, and paid taxes, should be permitted to elect the members of the colonial assembly, on which account the people of colour inferred, that this privilege was bestowed upon them. It is uncharitable to believe that this was the intention of the national assembly; but Gregoire and others carried their favourite point, that Mulattoes born of free parents might not only elect their own representatives, but also sit as members in the colonial assemblies. In consequence of this measure, all the white people fell victims to the indignation of the people of colour. The negroes were now fully determined to recover their liberty. On the 23d of August 1791, the people in the town of the Cape were informed that the slaves in the adjacent parishes had revolted, a report which was too soon confirmed by the arrival of those who had escaped the massacre. Hostilities commenced between the two parties, and terminated with the loss of 2000 white peo-

ple, while not fewer than 10,000 Mulattoes and Negroes perished by famine and the sword, and several hundreds by the hands of the executioner.

The news of these transactions having reached Paris, the members of the assembly were persuaded that they had carried their principles of equality by much too far, and they repealed their celebrated decree which had placed the people of colour on a footing with the whites. Commissioners (three in number) were sent to restore peace between the whites and Mulattoes, but as two of them were men of infamous characters, and incapable of extinguishing the flames of rebellion, they returned to France without being able to accomplish the object of their mission.

The *Amis des Noirs* having again acquired the superiority in the national assembly, Santhonax, Polverel, and Ailhaud, with 6000 men from the national guards, were ordered for St Domingo. The governor of the island perceiving that these commissioners took all the authority on themselves, and resolved to reduce him to a cypher, he remonstrated against their proceedings, in consequence of which he was immediately arrested, and sent a state prisoner to France. The commissioners afterwards disagreeing among themselves, Ailhaud was dismissed from their councils.

Unsuccessful attempts were made by the British government to subdue the commissioners and their adherents; but after performing prodigies of valour, the troops of Britain were compelled to relinquish the island, more perhaps by disease than the sword of the enemy. The chief government of it then fell into the hands of Toussaint L'Ouverture, by whom it was converted into an independent republic, the supreme authority over which he continued to hold till the signing the preliminaries of peace in 1801.

When this event took place, Bonaparte, with the consent of the British government, sent a fleet from Brest, with a considerable army under the command of General Le Clerc, who, after various actions, at length subdued Toussaint; and, notwithstanding that French general pledged himself for his safety, he was in a short time sent prisoner to France, where he soon after died, or, according to conjectures not very improbable, was put to death by order, or with the connivance, of the ruler of that kingdom.

The French troops under General Rochambeau being obliged to evacuate Hispaniola, the freedom and independence of the island were proclaimed by the conquering chief, Dessalines, who assured all those who were willing to remain in it, of his cordial protection, and allowing such as were so inclined freely to depart with the French army. The successes which attended the arms of this black chief, and the goodness of the cause in which he fought, were very much tarnished by the horrid massacres of the white people, which he not only countenanced, but attended in person. Attempts to negotiate with Dessalines were made by the British government, but without effect, his demands were so extravagant which he held out as the basis; but his army was in such a forlorn condition, as to create no apprehensions of danger from such an enemy. After this, however, Dessalines experienced a signal defeat on the plain of St Charles from General Ferrand, when 1200 of his men were found dead on the field, and himself obliged to retire towards the Cape.

Civil
History.

Europe, under the various names of *Gauls*, *Cimbrians*, *Goths*, &c. and who also migrated to Spain, where they were called *Celtiberians*. From *Magog*, *Meshech*, and *Tubal*, three of *Gomer's* brethren, proceeded the *Scythians*, *Sarmatians*, *Tartars*, and *Moguls*. The three other sons of *Japhet*, *Madai*, *Javan*, and *Tiras*, are said to have been the fathers of the *Medes*, the *Ionians*, *Greeks* and *Thracians*.

8
From Shem

The children of *Shem* were *Elam*, *Ashur*, *Arphaxad*, *Lud* and *Aram*. The first settled in *Persia*, where he was the father of that mighty nation: The descendants of *Ashur* peopled *Assyria* (now *Curdestan*): *Arphaxad* settled in *Chaldea*. *Lud* is supposed by *Josephus* to have taken up his residence in *Lydia*; though this is much controverted. *Aram*, with more certainty, is thought to have settled in *Mesopotamia* and *Syria*.

9
From Ham.

The children of *Ham* were *Cush*, *Mizraim*, *Phut*, and *Canaan*. The first is thought to have remained in *Babylonia*, and to have been king of the south-eastern parts of it, afterwards called *Khuzestan*. His descendants are supposed to have removed into the eastern parts of *Arabia*; from whence they by degrees migrated into the corresponding parts of *Africa*. The second peopled *Egypt*, *Ethiopia*, *Cyrenaica*, *Libya*, and the rest of the northern parts of the same continent. The place where *Phut* settled is not known: but *Canaan* is universally allowed to have settled in *Phœnicia*; and to have founded those nations who inhabited *Judea*, and were afterwards exterminated by the *Jews*.

Almost all the countries of the world, at least of the eastern continent, being thus furnished with inhabitants, it is probable that for many years there would be few or no quarrels between the different nations. The paucity of their numbers, their distance from one another, and their diversity of language, would contribute to keep them from having much communication with each other. Hence according to the different circumstances in which the different tribes were placed, some would be more civilized and others more barbarous. In this interval also the different nations probably acquired different characters, which afterwards they obstinately retained, and manifested on all occasions; hence the propensity of some nations to monarchy, as the *Asiatics*, and the enthusiastic desire of the *Greeks* for liberty and republicanism, &c.

10
Foundation
of the king-
doms of
Babylonia,
Assyria,
&c.

The beginning of monarchical government was very early; *Nimrod* the son of *Cush* having found means to make himself king of *Babylonia*. In a short time *Ashur* emigrated from the new kingdom; built *Nineveh*, afterwards capital of the *Assyrian* empire; and two other cities, called *Rezen* and *Rehoboth*, concerning the situation of which we are now much in the dark. Whether *Ashur* at this time set up as a king for himself, or whether he held these cities as vassal to *Nimrod*, is now unknown. It is probable, however, that about the same time various kingdoms were founded in different parts of the world; and which were great or small according to different circumstances. Thus the *Scripture* mentions the kings of *Egypt*, *Gerar*, *Sodom*, *Gomorrha*, &c. in the time of *Abraham*; and we may reasonably suppose, that these kings reigned over nations which had existed for some considerable time before.

Civil
History.

The first considerable revolution we read of is the migration of the *Israelites* out of *Egypt*, and their establishment in the land of *Canaan*. For the history of these transactions we must refer to the *Old Testament*, where the reader will see that it was attended with the most terrible catastrophe to the *Egyptians*, and resulted with the utter extermination of some nations, the descendants of *Ham*, who inhabited *Judea*. Whether the overthrow of *Pharaoh* in the *Red sea* could affect the *Egyptian* nation in such a manner as to deprive them of the greatest part of their former learning, and to keep them for some ages after in a barbarous state, is not easily determined; but unless this was the case, it seems exceedingly difficult to account for the total silence of their records concerning such a remarkable event, and indeed for the general confusion and uncertainty in which the early history of *Egypt* is involved. The settlement of the *Jews* in the promised land of *Canaan*, is supposed to have happened about 1491 B. C.

For near 200 years after this period, we find no accounts of any other nation than those mentioned in *Scripture*. About 1280 B. C. the *Greeks* began to make other nations feel the effects of that enterprising and martial spirit for which they were so remarkable, and which they had undoubtedly exercised upon one another long before. Their first enterprise was an invasion of *Colchis* (now *Mingrelia*), for the sake of the golden fleece. Whatever was the nature of this expedition, it is probable they succeeded in it; and it is likewise probable, that it was this specimen of the riches of *Asia* which inclined them so much to *Asiatic* expeditions ever after. All this time we are totally in the dark about the state of *Asia* and *Africa*, except in so far as can be conjectured from *Scripture*. The ancient empires of *Babylon*, *Assyria*, and *Persia*, probably still continued in the former continent, and *Egypt* and *Ethiopia* seem to have been considerable kingdoms in the latter.

About 1184 years B. C. the *Greeks* again distinguished themselves by their expedition against *Troy*, a city of *Phrygia Minor*; which they plundered and burnt, massacring the inhabitants with the most unrelenting cruelty. *Aeneas*, a *Trojan* prince, escaped with some followers into *Italy*, where he became the remote founder of the *Roman* empire. At this time *Greece* was divided into a number of small principalities, most of which seem to have been in subjection to *Agamemnon* king of *Mycenæ*. In the reign of *Atreus*, the father of this *Agamemnon*, the *Heraclidæ*, or descendants of *Hercules*, who had been formerly banished by *Eurystheus*, were again obliged to leave this country. Under their champion *Hyllus* they claimed the kingdom of *Mycenæ* as their right, pretending that it belonged to their great ancestor *Hercules*, who was unjustly deprived of it by *Eurystheus* *. The controversy was decided by single combat; but *Hyllus* being killed, they departed, as had been before agreed, under a promise of not making any attempt to return for 50 years. About the time of the *Trojan* war, also, we find the *Lydians*, *Mysiens*, and some other nations of *Asia Minor*, first mentioned in history. The names of the *Greek* states mentioned during this uncertain period are, 1. *Sicyon*. 2. *Leleg*. 3. *Messina*. 4. *Athens*. 5. *Crete*. 6. *Argos*. 7. *Sparta*. 8. *Pelagias*. 9. *Thessaly*.

* See Her-
cules.

HISTORY.

Civil History.

ect. I.

Civil History.

- 9. Thessaly. 10. Attica. 11. Phocia. 12. Locris.
- 13. Ozela. 14. Corinth. 15. Eleusina. 16. Elis.
- 17. Pilus. 18. Arcadia. 19. Egina. 20. Ithaca.
- 21. Cephalone. 22. Phthia. 23. Phocidia. 24. Ephyra. 25. Eolia. 26. Thebes. 27. Calista. 28. Etolia. 29. Doloppa. 30. Oeochalia. 31. Mycenæ.
- 32. Eubœa. 33. Mynia. 34. Doris. 35. Phera.
- 36. Iola. 37. Trachina. 38. Thrasprocia. 39. Myrmidonia. 40. Salamine. 41. Scyros. 42. Hype-ria or Melité. 43. The Vulcanian isles. 44. Megara.
- 45. Epirus. 46. Achaia. 47. The isles of the Egean sea. Concerning many of these we know nothing besides their names: the most remarkable particulars concerning the rest may be found under their respective articles.

13 the wa.

About 1048 B. C. the kingdom of Judea under King David approached its utmost extent of power. In its most flourishing condition, however, it never was remarkable for the largeness of its territory. In this respect it scarce exceeded the kingdom of Scotland; though, according to the accounts given in scripture, the magnificence of Solomon was superior to that of the most potent monarchs on earth. This extraordinary wealth, was owing partly to the spoils amassed by King David in his conquests over his various enemies, and partly to the commerce with the East Indies which Solomon had established. Of this commerce he owed his share to the friendship of Hiram king of Tyre, a city of Phœnicia, whose inhabitants were now the most famed for commerce and skill in maritime affairs of any in the whole world.

After the death of Solomon, which happened about 975 B. C. the Jewish empire began to decline; and soon after many powerful states arose in different parts of the world. The disposition of mankind in general seems now to have taken a new turn, not easily accounted for. In former times, whatever wars might have taken place between neighbouring nations, we have no account of any extensive empire in the whole world, or that any prince undertook to reduce far distant nations to his subjection. The empire of Egypt indeed is said to have been extended immensely to the east, even before the days of Sesostris. Of this country, however, our accounts are so imperfect, that scarce any thing can be concluded from them. But now, as it were all at once, we find almost every nation aiming at universal monarchy, and refusing to set any bounds whatever to its ambition. The first shock given to the Jewish grandeur was the division of the kingdom into two, through the imprudence of Rehoboam. This rendered it more easily a prey to Shishak king of Egypt; who five years after came and pillaged Jerusalem, and all the fortified cities of the kingdom of Judah. The commerce to the East Indies was now discontinued, and consequently the sources of wealth in a great measure stopped; and this, added to the perpetual wars between the kings of Israel and Judah, contributed to that remarkable and speedy decline which is now so easily to be observed in the Jewish affairs.

Whether this king Shishak was the Sesostris of profane writers or not, his expedition against Jerusalem as recorded in scripture seems very much to resemble the desultory conquests ascribed to Sesostris. His infantry is said to have been innumerable, composed of

different African nations; and his cavalry 60,000, with 1200 chariots; which agrees pretty well with the mighty armament ascribed to Sesostris, and of which an account is given under the article EGYPT, N^o 2. There indeed his cavalry are said to have been only 24,000; but the number of his chariots is increased to 27,000; which last may not unreasonably be reckoned an exaggeration, and these supernumerary chariots may have been only cavalry; but unless we allow Sesostris to be the same with Shishak, it seems impossible to fix on any other king of Egypt that can be supposed to have undertaken this expedition in the days of Solomon.

Though the Jews obtained a temporary deliverance from Shishak, they were quickly after attacked by new enemies. In 941 B. C. one Zerah an Ethiopian invaded Judæa with an army of a million of infantry and 300 chariots; but was defeated with great slaughter by Asa king of Judah, who engaged him with an army of 580,000 men. About this time also we find the Syrians grown a considerable people, and bitter enemies both to the kings of Israel and Judah; aiming in fact at the conquest of both nations. Their kingdom commenced in the days of David, under Hadadezer, whose capital was Zobah, and who probably was at last obliged to become David's tributary, after having been defeated by him in several engagements. Before the death of David, however, one Rezon, who it seems had rebelled against Hadadezer, having found means to make himself master of Damascus, erected there a new kingdom, which soon became very powerful. The Syrian princes being thus in the neighbourhood of the two rival states of Israel and Judah (whose capitals were Samaria and Jerusalem), found it an easy matter to weaken them both, by pretending to assist the one against the other; but a detail of the transactions between the Jews and Syrians is only to be found in the Old Testament, to which we refer. In 740 B. C. however, the Syrian empire was totally destroyed by Tiglath Pileser king of Assyria; as was also the kingdom of Samaria by Shalmaneser his successor in 721 B. C. The people were either massacred, or carried into captivity into Media, Persia, and the countries about the Caspian sea.

14 Of the Syrians.

While the nations of the east were thus destroying each other, the foundations of very formidable empires were laid in the west, which in process of time were to swallow up almost all the eastern ones. In Africa, Carthage was founded by a Tyrian colony, about 869 B. C. according to those who ascribe the highest antiquity to that city; but, according to others, it was founded only in 769 or 770 B. C. In Europe a very considerable revolution took place about 900 B. C. The Heraclidæ, whom we have formerly seen expelled from Greece by Atreus the father of Agamemnon, after several unsuccessful attempts, at last conquered the whole Peloponnesus. From this time the Grecian states became more civilized, and their history becomes less obscure. The institution, or rather the revival and continuance, of the Olympic games, in 776 B. C. also greatly facilitated the writing not only of their history, but that of other nations; for as each Olympiad consisted of four years, the chronology of every important event became indubitably fixed by referring it to such and such an Olympiad. In 748 B. C.

15 Of the Western nations.

Civil
History.

or the last year of the seventh Olympiad, the foundations of the city of Rome were laid by Romulus; and, 43 years after, the Spartan state was new modelled, and received from Lycurgus those laws, by observing of which it afterwards arrived at such a pitch of splendor.

16
State of the
world at
the begin-
ning of the
third gene-
ral period.

3. With the beginning of the 28th Olympiad, or 568 B. C. commences the third general period above-mentioned, when profane history becomes somewhat more clear, and the relations concerning the different nations may be depended upon with some degree of certainty. The general state of the world was at that time as follows.—The northern parts of Europe were either thinly inhabited, or filled with unknown and barbarous nations, the ancestors of those who afterwards destroyed the Roman empire. France and Spain were inhabited by the Gomerians or Celtes. Italy was divided into a number of petty states, arising partly from Gaulish and partly from Grecian colonies; among whom the Romans had already become formidable. They were governed by their king Servius Tullius; had increased their city by the demolition of Alba Longa, and the removal of its inhabitants to Rome; and had enlarged their dominions by several cities taken from their neighbours. Greece was also divided into a number of small states, among which the Athenians and Spartans, being the most remarkable, were rivals to each other. The former had, about 599 B. C. received an excellent legislation from Solon, and were enriching themselves by navigation and commerce: the latter were become formidable by the martial institutions of Lycurgus; and having conquered Messina, and added its territory to their own, were justly esteemed the most powerful people in Greece. The other states of most consideration were Corinth, Thebes, Argos, and Arcadia. In Asia great revolutions had taken place. The ancient kingdom of Assyria was destroyed by the Medes and Babylonians, its capital city Nineveh utterly ruined, and the greatest part of its inhabitants carried to Babylon. Nay, the very materials of which it was built were carried off, to adorn and give strength to that stately metropolis, which was then undoubtedly the first city in the world. Nebuchadnezzar, a wise and valiant prince, now sat on the throne of Babylon. By him the kingdom of Judæa was totally overthrown in 587 B. C. Three years before this he had taken and razed the city of Tyre, and overrun all the kingdom of Egypt. He is even said by Josephus to have conquered Spain, and reigned there nine years, after which he abandoned it to the Carthaginians; but this seems by no means probable. The extent of the Babylonian empire is not certainly known: but from what is recorded of it we may conclude, that it was not at all inferior even in this respect to any that ever existed; as the scripture tells us it was superior in wealth to any of the succeeding ones. We know that it comprehended Phœnicia, Palestine, Syria, Babylonia, Media, and Persia, and not improbably India also; and from a consideration of this vast extent of territory, and the riches with which every one of these countries abounded, we may form some idea of the wealth and power of this monarch. When we consider also, that the whole strength of this mighty empire was employed in beautifying the metropolis, we cannot look upon the wonders of

that city as related by Herodotus to be at all incredible. See BABYLON; and ARCHITECTURE, N^o 13. As to what passed in the republic of Carthage about this time, we are quite in the dark; there being a chasm in its history for no less than 300 years.

Civil
History.

4. The fourth general period of history, namely, ¹⁷Fourth pe- from the end of the fabulous times to the conquest of riod. Mi- Babylon by Cyrus, is very short, including no more than 31 years. This sudden revolution was occasioned by the misconduct of Evil-merodach, Nebuchadnezzar's son, even in his father's life-time. For having, in a great hunting match on occasion of his marriage, entered the country of the Medes, and some of his troops coming up at the same time to relieve the garrisons in those places, he joined them to those already with him, and without the least provocation began to plunder and lay waste the neighbouring country. This produced an immediate revolt, which quickly extended over all Media and Persia. The Medes, headed by Astyages and his son Cyaxares, drove back Evil-merodach and his party with great slaughter; nor doth it appear that they were afterwards reduced even by Nebuchadnezzar himself. The new empire continued daily to gather strength; and at last Cyrus, Astyages's grandson, a prince of great prudence and valour, being made generalissimo of the Median and Persian forces, took Babylon itself in the year 538 B. C. as related under the article BABYLON.

During this period the Romans increased in power ¹⁸Of the under the wise administration of their king Servius Romans, Tullius, who, though a pacific prince, rendered his Greeks, people more formidable by a peace of 20 years than Lydians, his predecessors had done by all their victories. The and Per- Greeks, even at this early period, began to interfere with the Persians, on account of the Ionians or Grecian colonies in Asia Minor. These had been subdued by Croesus king of Lydia about the year 562, the time of Nebuchadnezzar's death. Whether the Lydians had been subdued by the Babylonish monarch or not, is not now to be ascertained; though it is very probable that they were either in subjection to him, or greatly awed by his power, as before his death nothing considerable was undertaken by them. It is indeed probable, that during the insanity of Nebuchadnezzar, spoken of by Daniel, the affairs of his kingdom would fall into confusion; and many of those princes whom he formerly retained in subjection would set up for themselves. Certain it is, however, that if the Babylonians did not regard Croesus as their subject, they looked upon him to be a very faithful ally; inasmuch that they celebrated an annual feast in commemoration of a victory obtained by him over the Scythians. After the death of Nebuchadnezzar, Croesus subdued many nations in Asia Minor, and among the rest the Ionians, as already related. They were, however, greatly attached to his government; for though they paid in tribute, and were obliged to furnish him with some forces in time of war, they were yet free from all kind of oppression. When Cyrus therefore was proceeding in his conquests of different parts of the Babylonish empire, before he proceeded to attack the capital, the Ionians refused to submit to him, though he offered them very advantageous terms. But soon after, Croesus himself being defeated and taken prisoner, the Ionians sent ambassadors to Cyrus, offering

Civil
History.Civil
History.

to submit on the terms which had formerly been proposed. These terms were now refused; and the Ionians, being determined to resist, applied to the Spartans for aid. Though the Spartans at that time could not be prevailed upon to give their countrymen any assistance, they sent ambassadors to Cyrus with a threatening message; to which he returned a contemptuous answer, and then forced the Ionians to submit at discretion, five years before the taking of Babylon. Thus commenced the hatred between the Greeks and Persians; and thus we see, that in the two first great monarchies the seeds of their destruction were sown even before the monarchies themselves were established. For while Nebuchadnezzar was raising the Babylonish empire to its utmost height, his son was destroying what his father built up; and at the very time when Cyrus was establishing the Persian monarchy, by his ill-timed severity to the Greeks he made that warlike people his enemies, whom his successors were by no means able to resist, and who would probably have overcome Cyrus himself, had they united in order to attack him. The transactions of Africa during this period are almost entirely unknown; though we cannot doubt that the Carthaginians enriched themselves by means of their commerce, which enabled them afterwards to attain such a considerable share of power.

19
h gene-
period.
tory of
Jews,
yloni-
Egypt-
, &c.

5. Cyrus having now become master of all the east, the Asiatic affairs continued for some time in a state of tranquillity. The Jews obtained leave to return to their own country, rebuild their temple, and again establish their worship, of all which an account is given in the sacred writings, though undoubtedly they must have been in a state of dependence on the Persians from that time forward. Cambyses the successor of Cyrus added Egypt to his empire, which had either not submitted to Cyrus, or revolted soon after his death. He intended also to have subdued the Carthaginians; but as the Phœnicians refused to supply him with ships to fight against their own countrymen, he was obliged to lay this design aside.

In 517 B. C. the Babylonians finding themselves grievously oppressed by their Persian masters, resolved to shake off the yoke, and set up for themselves. For this purpose, they took care to store their city with all manner of provisions; and when Darius Hystaspes, then king of Persia, advanced against them, they took the most barbarous method that can be imagined of preventing an unnecessary consumption of those provisions, which they had so carefully amassed. Having collected all the women, old men, and children, into one place, they strangled them without distinction, whether wives, fathers, mothers, brothers, or sisters; every one being allowed to save only the wife he liked best, and a maid servant to do the work of the house. This cruel policy did not avail them: their city was taken by treachery (for it was impossible to take it by force); after which the king caused the walls of it to be beaten down from 200 to 50 cubits height, that their strength might no longer give encouragement to the inhabitants to revolt. Darius then turned his arms against the Scythians; but finding that expedition turn out both tedious and unprofitable, he directed his course eastward, and reduced all the country as far as the river Indus. In the mean time, the Ionians revolted; and being assisted by the Greeks, a

war commenced between the two nations, which was not thoroughly extinguished but by the destruction of the Persian empire in 330 B. C. The Ionians, however, were for this time obliged to submit, after a war of six years; and were treated with great severity by the Persians. The conquest of Greece itself was then projected: but the expeditions for that purpose ended most unfortunately for the Persians, and encouraged the Greeks to make reprisals on them, in which they succeeded according to their utmost wishes; and had it only been possible for them to have agreed among themselves, the downfall of the Persian empire would have happened much sooner than it did. See ATHENS, SPARTA, MACEDON, and PERSIA.

In 459 B. C. the Egyptians made an attempt to recover their liberty, but were reduced after a war of six years. In 413 B. C. they revolted a second time: and being assisted by the Sidonians, drew upon the latter that terrible destruction foretold by the prophets; while they themselves were so thoroughly humbled, that they never after made any attempt to recover their liberty.

The year 403 B. C. proved remarkable for the revolt of Cyrus against his brother Artaxerxes Memnon; in which, through his own rashness, he miscarried, and lost his life at the battle of Cunaxa, in the province of Babylon. Ten thousand Greek mercenaries, who served Xenophon's in his army, made their way back into Greece, though ²⁰retreat. surrounded on all sides by the enemy, and in the heart of a hostile country. In this retreat they were commanded by Xenophon, who has received the highest praises on account of his conduct and military skill in bringing it to a happy conclusion. Two years after, the invasions of Agesilaus king of Sparta threatened the Persian empire with total destruction; from which, however, it was relieved by his being recalled in order to defend his own country against the other Grecian states; and after this the Persian affairs continued in a more prosperous way till the time of Alexander.

During all this time, the volatile and giddy temper ²¹History of the Greeks. of the Greeks, together with their enthusiastic desire of romantic exploits, were preparing fetters for themselves, which indeed seemed to be absolutely necessary to prevent them from destroying one another. A zeal for liberty was what they all pretended; but on every occasion it appeared, that this love of liberty was only a desire of dominion. No state in Greece could bear to see another equal to itself; and hence their perpetual contests for pre-eminence, which could not but weaken the whole body, and render them an easy prey to an ambitious and politic prince, who was capable of taking advantage of those divisions. Being all equally impatient of restraint, they never could bear to submit to any regular government; and hence their determinations were nothing but the decisions of a mere mob, of which they had afterwards almost constantly reason to repent. Hence also their base treatment of those eminent men whom they ought most to have honoured; as Miltiades, Aristides, Themistocles, Alcibiades, Socrates, Phocion, &c. The various transactions between the Grecian states, though they make a very considerable figure in particular history, make none at all in a general sketch of the history of the world. We shall therefore only observe, that in 404 B. C. the Athenian power was in a manner totally broken by the taking

Civil
History.

taking of their city by the Spartans. In 370 B. C. that of the Spartans received a severe check from the Thebans at the battle of Leuctra; and eight years after was still further reduced by the battle of Mantinea. Epaminondas the great enemy of the Spartans was killed; but this only proved a more speedy means of subjugating all the states to a foreign, and at that time despicable, power. The Macedonians, a barbarous nation, lying to the north of the states of Greece, were two years after the death of Epaminondas reduced to the lowest ebb by the Illyrians, another nation of barbarians in the neighbourhood. The king of Macedon being killed in an engagement, Philip his brother departed from Thebes, where he had studied the art of war under Epaminondas, in order to take possession of his kingdom. Being a man of great prudence and policy, he quickly settled his own affairs; vanquished the Illyrians; and being no stranger to the weakened situation of Greece, began almost immediately to meditate the conquest of it. The particulars of this enterprise are related under the article MACEDON: here it is sufficient to take notice, that by first attacking those he was sure he could overcome, by corrupting those whom he thought it dangerous to attack, by sometimes pretending to assist one state and sometimes another, and by imposing upon all as best served his turn, he at last put it out of the power of the Greeks to make any resistance; at least such as could keep him from gaining his end. In 338 B. C. he procured himself to be elected general of the Amphictyons, or council of the Grecian states, under pretence of settling some troubles at that time in Greece; but having once obtained liberty to enter that country with an army, he quickly convinced the states that they must all submit to his will. He was opposed by the Athenians and Thebans; but the intestine wars of Greece had cut off all her great men, and no general was now to be found capable of opposing Philip with success.

The king of Macedon, being now master of all Greece, projected the conquest of Asia. To this he was encouraged by the ill success which had attended the Persians in their expeditions against Greece, the successes of the Greeks in their invasions, and the retreat of the ten thousand under Xenophon. All these events showed the weakness of the Persians, their vast inferiority to the Greeks in military skill, and how easily their empire might be overthrown by a proper union among the states.

Philip was preparing to enter upon his grand design, when he was murdered by some assassins. His son Alexander was possessed of every quality necessary for the execution of so great a plan; and his impetuosity of temper made him execute it with a rapidity unheard of either before or since. It must be confessed, indeed, that the Persian empire was now ripe for destruction, and could not in all probability have withstood an enemy much less powerful than Alexander. The Asiatics have in all ages been much inferior to the European nations in valour and military skill. They were now sunk in luxury and effeminacy; and what was worse, they seem at this period to have been seized with that infatuation and distraction of councils which scarce ever fails to be a forerunner of the destruction of any nation. The Persian ministers persuaded their sovereign to reject the prudent advice that was given

him, of distressing Alexander by laying waste the country, and thus forcing him to return for want of provisions. Nay, they even prevented him from engaging the enemy in the most proper manner, by dividing his forces; and persuaded him to put Charidemus the Athenian to death, who had promised with 100,000 men, of whom one-third were mercenaries, to drive the Greeks out of Asia. In short, Alexander met with only two checks in his Persian expedition. The one was from the city of Tyre, which for seven months resisted his utmost efforts; the other was from Memnon the Rhodian, who had undertaken to invade Macedonia. The first of these obstacles Alexander at last got over, and treated the governor and inhabitants with the utmost cruelty. The other was scarce felt; for Memnon died after reducing some of the Grecian islands, and Darius had no other general capable of conducting the undertaking. The power of the Persian empire was totally broken by the victory gained over Darius at Arbela in 331 B. C. and next year a total end was put to it by the murder of the king by Bessus one of his subjects.

The ambition of Alexander was not to be satisfied with the possession of the kingdom of Persia, or indeed of any other on earth. Nothing less than the total subjection of the world itself seemed sufficient to him; and therefore he was now prompted to invade every country of which he could only learn the name, whether it had belonged to the Persians or not. In consequence of this disposition, he invaded and reduced Hyrcania, Bactria, Sogdia, and all that vast tract of country now called *Bukharia*. At last, having entered India, he reduced all the nations to the river *Hypphasia*, one of the branches of the Indus. But when he would have proceeded farther, and extended his conquests quite to the eastern extremities of Asia, his troops positively refused to follow him farther, and he was constrained to return. In 323 B. C. this mighty conqueror died of a fever; without having time to settle the affairs of his vast extended empire, or even to name his successor.

While the Grecian empire thus suddenly sprung up in the east, the rival states of Rome and Carthage were making considerable advances in the west. The Romans were establishing their empire on the most solid foundations; to which their particular situation naturally contributed. Being originally little better than a parcel of lawless banditti, they were despised and hated by the neighbouring states. This soon produced wars; in which, at first from accidental circumstances, and afterwards from their superior valour and conduct, the Romans proved almost constantly victorious. The jealousies which prevailed among the Italian states, and their ignorance of their true interest, prevented them from combining against that aspiring nation, and crushing it in its infancy, which they might easily have done; while in the mean time the Romans being kept in a state of continual warfare, became at last such expert soldiers, that no other state on earth could resist them. During the time of their kings they had made a very considerable figure among the Italian nations; but after their expulsion, and the commencement of the republic, their conquests became much more rapid and extensive. In 504 B. C. they subdued the Sabines; eight years after, the Latins; and in 399 B. C. the city

Civil
History.23
His conquest of other nations.24
History of the Romans.22
Conquest of Persia by Alexander.

Civil History.

Civil History.

city of Veii, the strongest in Italy, exceeding Rome itself, was taken after a siege of ten years. But in the midst of their successes a sudden irruption of the Gauls had almost put an end to their power and nation at once. The city was burnt to the ground in 383 B. C. and the capitol on the point of being surprised, when the Gauls, who were climbing up the walls in the night, were accidentally discovered and repulsed*. In a short time Rome was rebuilt with much greater splendor than before, but now a general revolt and combination of the nations formerly subdued took place. The Romans, however, still got the better of their enemies; but, even at the time of the celebrated Camillus's death, which happened about 352 B. C. their territories scarce extended six or seven leagues from the capital. The republic from the beginning was agitated by those dissensions which at last proved its ruin. The people had been divided by Romulus into two classes, namely, *Patricians* and *Plebeians*, answering to our nobility and commonalty. Between these two bodies were perpetual jealousies and contentions; which retarded the progress of the Roman conquests, and revived the hopes of the nations they had conquered. The tribunes of the people were perpetually opposing the consuls and military tribunes. The senate had often recourse to a dictator endowed with absolute power; and then the valour and experience of the Roman troops made them victorious; but the return of domestic seditions gave the subjugated nations an opportunity of shaking off the yoke. Thus had the Romans continued for near 400 years, running the same round of wars with the same enemies, and reaping very little advantage from their conquests, till at last matters were compounded by choosing one of the consuls from among the plebeians; and from this time chiefly we may date the prosperity of Rome, so that by the time that Alexander the Great died they were held in considerable estimation among foreign nations.

they possessed some part of the island as early as 505 B. C. For in the time of the first consul, the Romans and Carthaginians entered into a treaty chiefly in regard to matters of navigation and commerce; by which it was stipulated, that the Romans who should touch at Sardinia, or that part of Sicily which belonged to Carthage, should be received there in the same manner as the Carthaginians themselves. Whence it appears, that the dominion of Carthage already extended over Sardinia and part of Sicily: but in 28 years after, they had been totally driven out by Gelon: which probably was the first exploit performed by him. This appears from his speech to the Athenian and Spartan ambassadors who desired his assistance against the forces of Xerxes king of Persia. The Carthaginians made many attempts to regain their possessions in this island, which occasioned long and bloody wars between them and the Greeks, as related under the articles *CARTHAGE* and *SICILY*. This island also proved the scene of much slaughter and bloodshed in the wars of the Greeks with one another †. Before the year 323 B. C. however, the Carthaginians had made themselves masters of a very considerable part of the island; from whence all the power of the Greeks could not dislodge them. It is proper also to observe, that after the destruction of Tyre by Alexander the Great, almost all the commerce in the western part of the world fell to the share of the Carthaginians. Whether they had at this time made any settlements in Spain is not known. It is certain, that they traded to that country for the sake of the silver, in which it was very rich; as they probably also did to Britain for the tin with which it abounded.

† See Athens and Sparta.

26

6. The beginning of the sixth period presents us with a state of the world entirely different from the preceding. We now behold all the eastern part of the world, from the confines of Italy to the river Indus, and beyond it, newly united into one vast empire, and at the same time ready to fall to pieces for want of a proper head; the western world filled with fierce and savage nations, whom the rival republics of Carthage and Rome were preparing to enslave as fast as they could. The first remarkable events took place in the Macedonian empire.—Alexander, as already observed, had not distinctly named any successor; but he had left behind him a victorious, and, we may say, invincible army, commanded by most expert officers, all of them ambitious of supreme authority. It is not to be supposed that peace could long be preserved in such a situation. For a number of years, indeed, nothing was to be seen or heard of but the most horrid slaughters, and wickedness of every kind, until at last the mother, wives, children, brothers, and even sisters, of Alexander, were cut off; not one of the family of that great conqueror being left alive. When matters were a little settled, four new empires, each of them of no small extent, had arisen out of the empire of Alexander. Cassander, the son of Antipater, had Macedonia and all Greece; Antigonus, Asia Minor; Seleucus had Babylon and the eastern provinces; and Ptolemy Lagus, Egypt and the western ones. One of these empires, however, quickly fell; Antigonus being defeated and killed by Seleucus and Lysimachus at the battle of Ipsus, in 301 B. C. The greatest part of his dominions then fell to Seleucus; but several pro-

Sixth period. History of the Macedonian empire.

see me.

25 of the Carthaginians, and of Sicily.

The Carthaginians in the mean time continued to enrich themselves by commerce; but, being less conversant in military affairs, were by no means equal to the Romans in power, though they excelled them in wealth. A new state, however, makes its appearance during this period, which may be said to have taught the Carthaginians the art of war, and, by bringing them into the neighbourhood of the Romans, proved the first source of contention between these two powerful nations. This was the island of Sicily. At what time people were first settled on it, is not now to be ascertained. The first inhabitants we read of were called *Sicani*, *Siculi*, *Lastrigones*, &c. but of these we know little or nothing. In the second year of the 17th Olympiad, or 710 B. C. some Greek colonies are said to have arrived on the island, and in a short time founded several cities, of which Syracuse was the chief. The Syracusans at last subdued the original inhabitants: though it doth not appear that the latter were ever well affected to their government, and therefore were on all occasions ready to revolt. The first considerable prince, or (as he is called by the Greeks) *tyrant* of Syracuse, was Gelon, who obtained the sovereignty about the year 483 B. C. At what time the Carthaginians first carried their arms into Sicily is not certainly known; only we are assured, that

Civil
History.

vinces took the opportunity of these confusions to shake off the Macedonian yoke altogether: and those were formed the kingdoms of Pontus, Bithynia, Pergamus, Armenia, and Cappadocia. The two most powerful and permanent empires, however, were those of Syria founded by Seleucus, and Egypt by Ptolemy Lagus. The kings of Macedon, though they did not preserve the same authority over the Grecian states that Alexander, Antipater, and Cassander, had done, yet effectually prevented them from those outrages upon one another, for which they had formerly been so remarkable. Indeed, it is somewhat difficult to determine, whether their condition was better or worse than before they were conquered by Philip; since, though they were now prevented from destroying one another, they were most grievously oppressed by the Macedonian tyrants.

While the eastern parts of the world were thus deluged with blood, and the successors of Alexander were pulling to pieces the empire which he had established, the Romans and Carthaginians proceeded in their attempts to enslave the nations of the west. The Romans, ever engaged in war, conquered one city and state after another, till about the year 253 B. C. they had made themselves masters of almost the whole of Italy. During all this time they had met only with a single check in their conquests, and that was the invasion of Pyrrhus, king of Epirus. That ambitious and fickle prince had projected the conquest of Italy, which he fancied would be an easy matter. Accordingly in 271 B. C. he entered that country, and maintained a war with the Romans for six years, till at last, being utterly defeated by Curius Dentatus, he was obliged to return.

The Romans had no sooner made themselves masters of Italy, than they wanted only a pretence to carry their arms out of it, and this pretence was soon found out. Being invited into Sicily to assist the Mamertines against Hiero king of Syracuse and the Carthaginians, they immediately commenced a war with the latter, which continued with the utmost fury for 23 years. The war ended greatly to the disadvantage of the Carthaginians, chiefly owing to the bad conduct of their generals, none of whom, Hamilcar Barcas alone excepted, seem to have been possessed of any degree of military skill; and the state had suffered too many misfortunes before he entered upon the command, for him or any other to retrieve it at that time. The consequence of this war was the entire loss of Sicily to the Carthaginians; and soon after the Romans seized on the island of Sardinia.

Hamilcar perceiving that there was now no alternative, but that in a short time either Carthage must conquer Rome, or Rome would conquer Carthage, bethought himself of a method by which his country might become equal to that haughty republic. This was by reducing all Spain, in which the Carthaginians had already considerable possessions, and from the mines of which they drew great advantages. He had, therefore, no sooner finished the war with the mercenaries, which succeeded that with the Romans, than he set about the conquest of Spain. This, however, he did not live to accomplish, though he made great progress in it. His son Asdrubal continued the war with success; till at last the Romans, jealous of

Civil
History.

his progress, persuaded him to enter into a treaty with them, by which he engaged himself to make the river Iberus the boundary of his conquests. This treaty probably was never ratified by the senate of Carthage, nor, though it had, would it have been regarded by Hannibal, who succeeded Asdrubal in the command, and had sworn perpetual enmity with the Romans. The transactions of the second Punic war are perhaps the most remarkable which the history of the world can afford. Certain it is, that nothing can show more clearly the slight foundations upon which the greatest empires are built. We now see the Romans, the nation most remarkable for their military skill in the whole world, and who, for more than 500 years, had been constantly victorious, unable to resist the efforts of one single man. At the same time we see this man, though evidently the first general in the world, lost solely for want of a slight support. In former times, the republic of Carthage supplied her generals in Sicily with hundreds of thousands, though their enterprises were almost constantly unsuccessful; but now Hannibal, the conqueror of Italy, was obliged to abandon his design, merely for want of 20 or 30,000 men. That degeneracy and infatuation, which never fails to overwhelm a falling nation, or rather which is the cause of its fall, had now infected the councils of Carthage, and the supplies were denied. Neither was Carthage the only infatuated nation at this time.

Hannibal, whose prudence never forsook him either in prosperity or adversity, in the height of his good fortune had concluded an alliance with Philip king of Macedon. Had that prince sent an army to the assistance of the Carthaginians in Italy immediately after the battle of Cannæ, there can be no doubt but the Romans would have been forced to accept of that peace which they so haughtily refused †; and indeed, this offer of peace, in the midst of so much success, is an instance of moderation which perhaps does more honour to the Carthaginian general than all the military exploits he performed. Philip, however, could not be roused from his indolence, nor see that his own ruin was connected with that of Carthage. The Romans had now made themselves masters of Sicily; after which they recalled Marcellus, with his victorious army, to be employed against Hannibal; and the consequence at last was, that the Carthaginian armies, unsupported in Italy, could not conquer it, but were recalled into Africa, which the Romans had invaded. The southern nations seem to have been as blind to their own interest as the northern ones. They ought to have seen, that it was necessary for them to preserve Carthage from being destroyed; but instead of this, Masinissa king of Numidia allied with the Romans, and by his means Hannibal was overcome at the battle of Zama †, which finished the second Punic war, in 188 B. C.

The event of the second Punic war determined the fate of almost all the other nations in the world. At this time, indeed, the empires of Egypt, Syria, and Greece, had been promoting their own ruin by mutual wars and intestine divisions. The Syrian empire was now governed by Antiochus the Great, who seems to have had little right to such a title. His empire, though diminished by the defection of the Parthians, was still very powerful; and to him

Hannibal

27
Of the Romans and Carthaginians.

† See Carthage, No 126.

23
Of Egypt and Syria.

lect. I.

Civil History. Hannibal applied, after he was obliged to leave his country, as related under CARTHAGE, N^o 152. Antiochus, however, had not sufficient judgment to see the necessity of following that great man's advice; nor would the Carthaginians be prevailed upon to contribute their assistance against the nation which was soon to destroy them without any provocation. The pretence for war on the part of the Romans was, that Antiochus would not declare his Greek subjects in Asia to be free and independent states; a requisition which neither the Romans nor any other nation had a right to make. The event of all was, that Antiochus was everywhere defeated, and forced to conclude a peace upon very disadvantageous terms.

²⁹ **f Greece.** In Europe, matters went on in the same way; the states of Greece, weary of the tyranny of the Macedonians, entered into a resolution of recovering their liberties. For this purpose was framed the Achæan League^o; but as they could not agree among themselves, they at last came to the imprudent determination of calling in the Romans to defend them against Philip king of Macedon. This produced a war, in which the Romans were victorious. The Macedonians, however, were still formidable; and as the intention of the Romans to enslave the whole world could no longer be doubted, Perseus, the successor of Philip, renewed the war. Through his own cowardice he lost a decisive engagement, and with it his kingdom, which submitted to the Romans in 167 B. C.

³⁰ **destruction of Carthage and Corinth.** Macedon being thus conquered, the next step was utterly to exterminate the Carthaginians; whose republic, notwithstanding the many disasters that had befallen it, was still formidable. It is true, the Carthaginians were giving no offence; nay, they even made the most abject submissions to the republic of Rome; but all was not sufficient. War was declared a third time against that unfortunate state; there was now no Hannibal to command their armies, and the city was utterly destroyed 146 B. C. The same year the Romans put an end to the liberties they had pretended to grant the cities of Greece, by the entire destruction of CORINTH. See that article.

³¹ **history of Egypt, Syria, and Judæa.** After the death of Antiochus the Great, the affairs of Syria and Egypt went on from bad to worse. The degenerate princes which filled the thrones of those empires, regarding only their own pleasures, either spent their time in oppressing their subjects, or in attempting to deprive each other of their dominions, by which means they became a more easy prey to the Romans. So far indeed were they from taking any means to secure themselves against the overgrown power of that republic, that the kings both of Syria and Egypt sometimes applied to the Romans as protectors. Their downfall, however, did not happen within the period of which we now treat.—The only other transaction which makes any considerable figure in the Syrian empire is the oppression of the Jews by Antiochus Epiphanes. After their return from the Babylonish captivity, they continued in subjection to the Persians till the time of Alexander.—From that time they were subject to the kings of Egypt or Syria, as the fortune of either happened to prevail. Egypt being reduced to a low ebb by Antiochus Epiphanes, the Jews fell under his dominion; and being severely

treated by him, imprudently showed some signs of joy on a report of his death. This brought him against them with a powerful army; and in 170 B. C. he took Jerusalem by storm, committing the most horrid cruelties on the inhabitants, insomuch that they were obliged to hide themselves in caverns and in holes of rocks to avoid his fury. Their religion was totally abolished, their temple profaned, and an image of Jupiter Olympius set up on the altar of burnt-offerings: which profanation is thought to be the *abomination of desolation* mentioned by the prophet Daniel. This revolution, however, was of no long continuance. In 167 B. C. Mattathias restored the true worship in most of the cities of Judea; and in 168 the temple was purified, and the worship there restored by Judas Maccabæus. This was followed by a long series of wars between the Syrians and Jews, in which the latter were almost always victorious; and before these wars were finished, the destruction of Carthage happened, which puts an end to the sixth general period formerly mentioned.

³² 7. The beginning of the seventh period presents us with a view of the ruins of the Greek empire in the declining states of Syria and Egypt; both of them much circumscribed in bounds. The empire of Syria at first comprehended all Asia to the river Indus, and beyond it; but in 312 B. C. most of the Indian provinces were by Seleucus ceded to one *Sandrocottus*, or *Androcottus*, a native, who in return gave him 500 elephants. Of the empire of Sandrocottus we know nothing farther than that he subdued all the countries between the Indus and the Ganges; so that from this time we may reckon the greatest part of India independent on the Syro-Macedonian princes. In 250 B. C. however, the empire sustained a much greater loss by the revolt of the Parthians and Bactrians from Antiochus Theus. The former could not be subdued; and as they held in subjection to them the vast tract which now goes under the name of *Persia*, we must look upon their defection as an irreparable loss. Whether any part of their country was afterwards recovered by the kings of Egypt or Syria is not very certain; nor is it of much consequence, since we are assured that in the beginning of the seventh period, i. e. 146 B. C. the Greek empires of Syria and Egypt were reduced by the loss of India, Persia, Armenia, Pontus, Bithynia, Cappadocia, Pergamus, &c. The general state of the world in 146 B. C. therefore was as follows. In Asia were the empires of India, Parthia, and Syria, with the lesser states of Armenia, Pontus, &c. above mentioned; to which we must add that of Arabia, which during the sixth period had grown into some consequence, and had maintained its independency from the days of Ishmael the son of Abraham. In Africa were the kingdoms of Egypt and Ethiopia; the Carthaginian territories now subject to the Romans; and the kingdoms of Numidia, Mauritania, and Getulia, ready to be swallowed up by the same ambitious and insatiable power, now that Carthage was destroyed, which served as a barrier against it. To the south lay some unknown and barbarous nations, secure by reason of their situation and insignificance, rather than their strength, or distance from Rome. In Europe we find none to oppose the progress of the Roman arms, except the Gauls, Germans,

Civil
History.33
Conquests
of the Ro-
mans.

mans, and some Spanish nations. These were brave indeed; but through want of military skill, incapable of contending with such masters in the art of war as the Romans then were.

The Spaniards had indeed been subdued by Scipio Africanus in the time of the second Punic war: but, in 155 B. C. they revolted; and, under the conduct of one Viriathus, formerly a robber, held out for a long time against all the armies the Romans could send into Spain. Him the consul Cæpio caused to be murdered about 138 B. C. because he found it impossible to reduce him by force. The city of Numantia defied the whole Roman power for six years longer; till at last, by dint of treachery, numbers, and perseverance, it was not taken, but the inhabitants, reduced to extremity by famine, set fire to their houses, and perished in the flames or killed one another, so that not one remained to grace the triumph of the conqueror: and this for the present quieted the rest of the Spaniards. About the same time Attalus, king of Pergamus, left by will the Roman people heirs to all his goods; upon which they immediately seized on his kingdom as part of those goods, and reduced it to a Roman province, under the name of *Asia Proper*. Thus they continued to enlarge their dominions on every side, without the least regard to justice, to the means they employed, or to the miseries they brought upon the conquered people. In 122 B. C. the Balearic islands, now called *Majorca*, *Minorca*, and *Ivica*, were subdued, and the inhabitants exterminated; and soon after, several of the nations beyond the Alps were obliged to submit.

In Africa the crimes of Jugurtha soon gave this ambitious republic an opportunity of conquering the kingdoms of Numidia and Mauritania: and indeed this is almost the only war in which we find the Romans engaged where their pretensions had the least colour of justice; though in no case whatever could a nation show more degeneracy than the Romans did on this occasion. The particulars of this war are related under the articles NUMIDIA and ROME. The event of it was the total reduction of the former about the year 105 B. C. but Mauritania and Gætulia preserved their liberty for some time longer.

In the east, the empire of Syria continued daily to decline; by which means the Jews not only had an opportunity of recovering their liberty, but even of becoming as powerful, or at least of extending their dominions as far, as in the days of David and Solomon. This declining empire was still farther reduced by the civil dissensions between the two brothers Antiochus Grypus and Antiochus Cyzicenus; during which the cities of Tyre, Sidon, Ptolemais, and Gaza, declared themselves independent, and in other cities tyrants started up who refused allegiance to any foreign power. This happened about 100 B. C.; and 17 years after, the whole was reduced by Tigranes king of Armenia. On his defeat by the Romans, the latter reduced Syria to a province of their empire. The kingdom of Armenia itself, with those of Pontus, Cappadocia, and Bithynia, soon shared the same fate; Pontus, the most powerful of them all, being subdued about 64 B. C. The kingdom of Judea also was reduced under the same power much about this time. This state owed the loss of its liberty to the same

cause that had ruined several others, namely, calling in the Romans as arbitrators between two contending parties. The two sons of Alexander Jannæus (Hyrcaus and Aristobulus) contended for the kingdom. Aristobulus, being defeated by the party of Hyrcanus, applied to the Romans. Pompey the Great, who acted as ultimate judge in this affair, decided it against Aristobulus, but at the same time deprived Hyrcanus of all power as a king; not allowing him even to assume the regal title, or to extend his territory beyond the ancient borders of Judea. To such a length did Pompey carry this last article, that he obliged him to give up all those cities in Coelosyria and Phœnicia which had been gained by his predecessors, and added them to the newly acquired Roman province of Syria.

Thus the Romans became masters of all the eastern parts of the world, from the Mediterranean sea to the borders of Parthia. In the west, however, the Gauls were still at liberty, and the Spanish nations bore the Roman yoke with great impatience. The Gauls infested the territories of the republic by their frequent incursions, which were sometimes very terrible; and though several attempts had been made to subdue them, they always proved insufficient till the time of Julius Cæsar. By him they were totally reduced, from the river Rhine to the Pyrenean mountains, and many of their nations almost exterminated. He carried his arms also into Germany and the southern parts of Britain; but in neither of these parts did he make any permanent conquests. The civil wars between him and Pompey gave him an opportunity of seizing on the kingdom of Mauritania and those parts of Numidia which had been allowed to retain their liberty. The kingdom of Egypt alone remained, and to this nothing belonged except the country properly so called. Cyrenaica was bequeathed by will to the Romans about 58 B. C.; and about the same time the island of Cyprus was seized by them without any pretence, except a desire of possessing the treasure of the king.—The kingdom of Egypt continued for some time longer at liberty; which in some measure must be ascribed to the internal dissensions of the republic, but more especially to the amours of Pompey, Julius Cæsar, and Mark Antony, with the famous Cleopatra queen of Egypt. The battle of Actium, however, determined the fate of Antony, Cleopatra, and Egypt itself; which last was reduced to a Roman province about 9 B. C.

While the Romans thus employed all means to re-duce the world to their obedience, they were making one another feel the same miseries at home which they inflicted upon other nations abroad. The first civil dissensions took their rise at the siege of Numantia in Spain. We have already observed, that this small city resisted the whole power of the Romans for six years. Once they gave them a most terrible and shameful defeat, wherein 30,000 Romans fled before 4000 Numantines. Twenty thousand were killed in the battle, and the remaining ten thousand were shut up, that there was no possibility of escaping. In this extremity they were obliged to negotiate with the enemy, and a peace was concluded upon the following terms: 1. That the Numantines should suffer the Romans to retire unmolested; and, 2. That Numantia should maintain

Civil
History.34
Origin and
progress of
the civil
wars in
Rome.

Civil
History.

maintain its independence, and be reckoned among the Roman allies.—The Roman senate, with an injustice and ingratitude hardly to be matched, broke this treaty, and in return ordered the commander of their army to be delivered up to the Numantines; but they refused to accept of him, unless his army was delivered along with him; upon which the war was renewed, and ended as already related. The fate of Numantia, however, was soon revenged. Tiberius Sempronius Gracchus, brother-in-law to Scipio Africanus the second, had been a chief promoter of the peace with the Numantines already mentioned, and of consequence had been in danger of being delivered up to them along with the commander in chief. This disgrace he never forgot; and, in order to revenge himself, undertook the cause of the plebeians against the patricians, by whom the former were greatly oppressed. He began with reviving an old law, which had enacted that no Roman citizen should possess more than 500 acres of land. The overplus he designed to distribute among those who had no lands, and to reimburse the rich out of the public treasury. This law met with great opposition, bred many tumults, and at last ended in the death of Gracchus and the persecution of his friends, several hundreds of whom were put to cruel deaths without any form of law.

The disturbances did not cease with the death of Gracchus. New contests ensued on account of the Sempronian law, and the giving to the Italian allies the privilege of Roman citizens. This last not only produced great commotions in the city, but occasioned a general revolt of the states of Italy against the republic of Rome. This rebellion was not quelled without the utmost difficulty; and in the mean time, the city was deluged with blood by the contending factions of Sylla and Marius; the former of whom sided with the patricians, and the latter with the plebeians. These disturbances ended in the perpetual dictatorship of Sylla, about 80 B. C.

From this time we may date the loss of the Roman liberty; for though Sylla resigned his dictatorship two years after, the succeeding contests between Cæsar and Pompey proved equally fatal to the republic. These contests were decided by the battle of Pharsalia, by which Cæsar became in effect master of the empire in 43 B. C. Without loss of time he then crossed over into Africa; totally defeated the republican army in that continent; and, by reducing the country of Mauritania to a Roman province, completed the Roman conquests in these parts. His victory over the sons of Pompey at Munda 40 B. C. secured him from any further apprehensions of a rival. Being therefore sole master of the Roman empire, and having all the power of it at his command, he projected the greatest schemes; tending, according to some, not less to the happiness than to the glory of his country: when he was assassinated in the senate-house, in the 56th year of his age, and 39 B. C.

Without investigating the political justice of this action, or the motives of the perpetrators, it is impossible not to regret the death of this great man; when we contemplate his virtues, and the designs which he is said to have formed: (See ROME). Nor is it possible to justify, from ingratitude at least, even the most virtuous of the conspirators, when we consi-

Civil
History.

der the obligations under which they lay to him. And as to the measure itself, even in the view of expediency, it seems to be generally condemned. In fact, from the transactions which had long preceded, as well as those which immediately followed, the murder of Cæsar, it is evident, that Rome was incapable of preserving its liberty any longer, and that the people had become unfit for being free. The efforts of Brutus and Cassius were therefore unsuccessful, and ended in their own destruction and that of great numbers of their followers in the battle of Philippi. The defeat of the republicans was followed by numberless disturbances, murders, proscriptions, &c. till at last Octavianus, having cut off all who had the courage to oppose him, and finally got the better of his rivals by the victory at Actium, put an end to the republic in the year 27 B. C.

The destruction of the Roman commonwealth proved advantageous to the few nations of the world who still retained their liberty. That outrageous desire of conquest which had so long marked the Roman character, now in a great measure ceased; because there was now another way of satisfying the desires of ambitious men, namely, by courting the favour of the emperor. After the final reduction of the Spaniards, therefore, and the conquest of the countries of Mæsia, Pannonia, and some others adjacent to the Roman territories, and which in a manner seemed naturally to belong to them, the empire enjoyed for some time a profound peace.

The only remarkable transactions which took place during the remainder of the period of which we treat, were the conquest of Britain by Claudius and Agricola, and the destruction of Jerusalem by Vespasian and Titus. The war with the Jews began A. D. 67; and was occasioned by their obstinately claiming the city of Cæsarea, which the Romans had added to the province of Syria. It ended in 73, with the most terrible destruction of their city and nation; since which time they have never been able to assemble as a distinct people. The southern parts of Britain were totally subdued by Agricola about ten years after.

In the 98th year of the Christian era, Trajan was created emperor of Rome; and being a man of great valour and experience in war, carried the Roman conquests to their utmost extent. Having conquered the Dacians, a German nation beyond the Danube, and who had of late been very troublesome, he turned his arms eastward; reduced all Mesopotamia, Chaldæa, Assyria; and having taken Ctesiphon, the capital of the Parthian empire, appointed them a king, which he thought would be a proper method of keeping that warlike people in subjection. After this he proposed to return to Italy, but died by the way; and with his reign the seventh general period above mentioned is concluded.

8. The beginning of the eighth period presents us with a view of one vast empire, in which almost all the nations of the world were swallowed up. This empire comprehended the best part of Britain, all Spain, France, the Netherlands, Italy, part of Germany, Egypt, Barbary, Bildulgerid, Turkey in Europe, Turkey in Asia, and Persia. The state of India at this time is unknown. The Chinese lived in a remote part of the world, unheard of and unmolested by the western nations.

35
Octavianus
puts an end
to the re-
public.

Civil
History.

nations who struggled for the empire of the world. The northern parts of Europe and Asia were filled with barbarous nations, already formidable to the Romans, and who were soon to become more so. The vast empire of the Romans, however, had no sooner attained its utmost degree of power, than, like others before it, it began to decline. The provinces of Babylonia, Mesopotamia, and Assyria, almost instantly revolted, and were abandoned by Adrian the successor of Trajan in the empire. The Parthians having recovered their liberty, continued to be very formidable enemies, and the barbarians of the northern parts of Europe continued to increase in strength; while the Romans, weakened by intestine divisions, became daily less able to resist them. At different times, however, some warlike emperors arose, who put a stop to the incursions of these barbarians; and about the year 215, the Parthian empire was totally overthrown by the Persians, who had long been subject to them. This revolution proved of little advantage to the Romans. The Persians were enemies still more troublesome than the Parthians had been; and though often defeated, they still continued to infest the empire on the east, as the barbarous nations of Europe did on the north. In 260, the defeat and captivity of the emperor Valerian by the Persians, with the disturbances which followed, threatened the empire with utter destruction. Thirty tyrants seized the government at once, and the barbarians pouring in on all sides in prodigious numbers ravaged almost all the provinces of the empire. By the vigorous conduct of Claudius, Aurelian, Tacitus, Probus, and Carus, the empire was restored to its former lustre; but as the barbarians were only repulsed, and never thoroughly subdued, this proved only a temporary relief. What was worse, the Roman soldiers, growing impatient of restraint, commonly murdered those emperors who attempted to revive among them the ancient military discipline, which alone could ensure them victory over their enemies. Under Dioclesian, the disorders were so great, that though the government was held by two persons, they found themselves unable to bear the weight of it, and therefore took other two partners in the empire. Thus was the Roman empire divided into four parts; which by all historians is said to have been productive of the greatest mischiefs. As each of these four sovereigns would have as many officers both civil and military, and the same number of forces that had been maintained by the state when governed only by one emperor, the people were not able to pay the sums necessary for supporting them. Hence the taxes and imposts were increased beyond measure, the inhabitants in several provinces reduced to beggary, the land left untilld for want of hands, &c. An end was put to these evils when the empire was again united under Constantine the Great; but in 330 a mortal blow was given it, by removing the imperial seat to Byzantium, now Constantinople, and making it equal to Rome. The introduction and establishment of Christianity, already corrupted with the grossest superstitions, proved also a most grievous detriment to the empire. Instead of that ferocious and obstinate valour in which the Romans had so long been accustomed to put their trust, they now imagined themselves secured by signs of the cross, and other external symbols of the Christian

religion. These they used as a kind of magical incantations, which undoubtedly proved at all times ineffectual; and hence also in some measure proceeded the great revolution which took place in the next period.

9. The ninth general period shows us the decline and miserable end of the western part of the Roman empire. We see that mighty empire, which formerly occupied almost the whole world, now weakened by division, and surrounded by enemies. On the east, the Persians; on the north, the Scythians, Sarmatians, Goths, and a multitude of other barbarous nations, watched all occasions to break into it; and miscarried in their attempts, rather through their own barbarity, than the strength of their enemies. The devastations committed by those barbarians when they made their incursions are incredible, and the relation shocking to human nature. Some authors seem much inclined to favour them; and even insinuate, that barbarity and ignorant ferocity were their chief if not their only faults: but from their history it plainly appears, that not only barbarity and the most shocking cruelty, but the highest degree of avarice, perfidy, and disregard to the most solemn promises, were to be numbered among their vices. It was ever a sufficient reason for them to make an attack, that they thought their enemies could not resist them. Their only reason for making peace, or for keeping it, was because their enemies were too strong: and their only reason for committing the most horrid massacres, rapes, and all manner of crimes, was because they had gained a victory. The Romans, degenerate as they were, are yet to be esteemed much better than these savages; and therefore we find not a single province of the empire that would submit to the barbarians while the Romans could possibly defend them.

Some of the Roman emperors indeed withstood this inundation of savages; but as the latter grew daily more numerous, and the Romans continued to weaken themselves by their intestine divisions, they were at last obliged to take large bodies of barbarians into their pay, and teach them their military discipline, in order to drive away their countrymen, or others who invaded the empire. This at last proved its total destruction; for, in 476, the barbarians who served in the Roman armies, and were dignified with the title of *allies*, demanded the third part of the lands of Italy as a reward for their services: but meeting with a refusal, they revolted, and made themselves masters of the whole country, and of Rome itself, which from that time ceased to be the head of an empire of any consequence.

This period exhibits a most unfavourable view of the western parts of the world: The Romans, from the height of grandeur, sunk to the lowest slavery, nay, in all probability, almost exterminated; the provinces they formerly governed, inhabited by human beings scarce a degree above the brutes; every art and science lost; and the savage conquerors even in danger of starving for want of a sufficient knowledge of agriculture, having now no means of supplying themselves by plunder and robbery as before. Britain had long been abandoned to the mercy of the Scots and Picts; and in 450 the inhabitants had called in the Saxons to their assistance, whom they soon found worse enemies than those against whom they had im-

Civil
History.37
Ninth pe-
riod, De-
struction
of the
western
empire.38
General
state of the
world.

Civil history.

Civil History.

plored their aid. Spain was held by the Goths and Suevians; Africa (that is Barbary and Bildulgerid) by the Vandals; the Burgundians, Goths, Franks, and Alans, had erected several small states in Gaul; and Italy was subjected to the Heruli under Odoacer, who had taken upon him the title of *king of Italy*. In the east, indeed, matters wore an aspect somewhat more agreeable. The Roman empire continued to live in that of Constantinople, which was still very extensive. It comprehended all Asia Minor and Syria, as far as Persia; in Africa, the kingdom of Egypt; and Greece in Europe. The Persians were powerful, and rivalled the emperors of Constantinople; and beyond them lay the Indians, Chinese, and other nations, who, unheard-of by the inhabitants of the more western parts, enjoyed peace and liberty.

The Constantinopolitan empire continued to decline by reason of its continual wars with the Persians, Bulgarians, and other barbarous nations; to which also superstition and relaxation of military discipline largely contributed. The Persian empire also declined from the same causes, together with the intestine broils from which it was seldom free more than that of Constantinople. The history of the eastern part of the world during this period, therefore, consists only of the wars between these two great empires, of which an account is given under the articles CONSTANTINOPLE and PERSIA; and which were productive of no other consequence than that of weakening them both, and making them a more easy prey to those enemies who were now as it were in embryo, but shortly about to erect an empire almost as extensive as that of the Greeks or Romans.

Among the western nations, revolutions, as might naturally be expected from the character of the people, succeeded one another with rapidity. The Heruli under Odoacer were driven out by the Goths under Theodoric. The Goths were expelled by the Romans; and, while the two parties were contending, both were attacked by the Franks, who carried off an immense booty. The Romans were in their turn expelled by the Goths: the Franks again invaded Italy, and made themselves masters of the province of Venetia; but at last the superior fortune of the emperor of Constantinople prevailed, and the Goths were finally subdued in 553. Narses, the conqueror of the Goths, governed Italy as a province of the eastern empire till the year 568, when Longinus his successor made considerable alterations. The Italian provinces had ever since the time of Constantine the Great been governed by *consulares*, *correctores*, and *præsides*; no alteration having been made either by the Roman emperors, or the Gothic kings. But Longinus, being invested with absolute power by Justinian, suppressed those magistrates; and, instead of them, placed in each city of note a governor, whom he distinguished with the title of *duke*. The city of Rome was not more honoured than any other; for Longinus, having abolished the very name of *senate* and *consuls*, appointed a *duke* of Rome as well as of other cities. To himself he assumed the title of *esarch*; and, residing at Ravenna, his government was styled the *exarchate of Ravenna*. But while he was establishing this new empire, the greatest part of Italy was conquered by the Lombards.

In France a considerable revolution also took place,

In 487, Clovis, the founder of the French monarchy, possessed himself of all the countries lying between the Rhine and the Loire. - By force or treachery, he conquered all the petty kingdoms which had been erected in that country. His dominions had been divided, reunited, and divided again; and were on the point of being united a second time, when the great impostor Mahomet began to make a figure in the world.

In Spain, the Visigoths erected a kingdom ten years before the conquest of Rome by the Heruli. This kingdom they had extended eastward, about the same time that Clovis was extending his conquests to the west; so that the two kingdoms met at the river Loire. The consequence of this approach of such barbarous conquerors towards each other was an immediate war. Clovis proved victorious, and subdued great part of the country of the Visigoths, which put a final stop to their conquests on that side.

Another kingdom had been founded in the western parts of Spain by the Suevi, a considerable time before the Romans were finally expelled from that country. In 409, this kingdom was entirely subverted by Theodoric king of the Goths; and the Suevi were so pent up in a small district of Lusitania and Galicia, that it seemed impossible for them to recover themselves. During the above-mentioned period, however, while the attention of the Goths was turned another way, they had found means again to erect themselves into an independent state, and to become masters of considerably extended territories. But this success proved of short duration. In 584, the Goths attacked them; totally destroyed their empire a second time; and thus became masters of all Spain, except some small part which still owned subjection to the emperors of Constantinople. Of this part, however, the Goths became masters also in the year 623; which concludes the 9th general period.

Africa, properly so called, had changed its masters three times during this period. The Vandals had expelled the Romans, and erected an independent kingdom, which was at last overturned by the emperors of Constantinople; and from them the greatest part of it was taken by the Goths in 620.

10. At the commencement of the tenth general period (which begins with the flight of Mahomet the year 622, from whence his followers date their era called the *Hegira*), we see every thing prepared for the great revolution which was now to take place: the Roman empire in the west annihilated; the Persian empire and that of Constantinople weakened by mutual wars and intestine divisions; the Indians and other eastern nations unaccustomed to war, and ready to fall a prey to the first invader; the southern parts of Europe in a distracted and barbarous state; while the inhabitants of Arabia, from their earliest origin accustomed to war and plunder, and now united by the most violent superstition and enthusiastic desire of conquest, were like a flood pent up, and ready to overwhelm the rest of the world. The northern nations of Europe and Asia, however formidable in after times, were at present unknown, and peaceable, at least with respect to their southern neighbours; so that there was in no quarter of the globe any power capable of opposing the conquests of the Arabs. With

39
tory of
y.

40
rance.

Civil
History.

amazing celerity, therefore, they overran all Syria, Palestine, Persia, Bukharia, and India, extending their conquests farther to the eastward than ever Alexander had done. On the west side, their empire extended over Egypt, Barbary, and Spain, together with the islands of Sicily, Sardinia, Majorca, Minorca, &c. and many of the Archipelago islands; nor were the coasts of Italy itself free from their incursions; nay, they are even said to have reached the distant and barren country of Iceland. At last this great empire, as well as others, began to decline. Its ruin was very sudden, and owing to its internal divisions. Mahomet had not taken care to establish the apostleship in his family, or to give any particular directions about a successor. The consequence of this was, that the caliphate, or succession to the apostleship, was seized by many usurpers in different parts of the empire; while the true caliphs, who resided at Bagdad, gradually lost all power, and were regarded only as a kind of high-priests. Of these divisions the Turks took advantage to establish their authority in many provinces of the Mohammedan empire; but as they embraced the same religion with the Arabs, and were filled with the same enthusiastic desire of conquest, it is of little consequence to distinguish between them; as indeed it signified little to the world in general whether the Turks or Saracens were the conquerors, since both were cruel, barbarous, ignorant, and superstitious.

44
Of the
Pope's
temporal
power.

While the barbarians of the east were thus grasping at the empire of the whole world, great disturbances happened among the no less barbarous nations of the west. Superstition seems to have been the ruling motive in both cases. The Saracens and Turks conquered for the glory of God, or of his apostle Mahomet and his successors; the western nations professed an equal regard for the divine glory, but which was only to be perceived in the respect they paid to the pope and clergy. Ever since the establishment of Christianity by Constantine, the bishops of Rome had been gradually extending their power; and attempting not only to render themselves independent, but even to assume an authority over the emperors themselves. The destruction of the empire was so far from weakening their power, that it afforded them opportunities of greatly extending it, and becoming judges of the sovereigns of Italy themselves, whose barbarity and ignorance prompted them to submit to their decisions. All this time, however, they themselves had been in subjection to the emperors of Constantinople; but on the decline of that empire, they found means to get themselves exempted from this subjection. The principal authority in the city of Rome was then engrossed by the bishop; though of right it belonged to the duke appointed by the exarch of Ravenna. But though they had now little to fear from the eastern emperors, they were in great danger from the ambition of the Lombards, who aimed at the conquest of all Italy. This aspiring people the bishops of Rome determined to check; and therefore, in 726, when Luitprand king of the Lombards had taken Ravenna and expelled the exarch, the pope undertook to restore him. For this purpose he applied to the Venetians, who are now first mentioned in history as a state of any consequence; and by their means the exarch was restored. Some time before, a quarrel had happened between

Civil
History.

the pope (Gregory II.) and Leo emperor of the east, about the worship of images. Leo, who it seems, in the midst of so much barbarism, had still preserved some share of common sense and reason, reprobated the worship of images in the strongest terms, and commanded them to be destroyed throughout his dominions. The pope, whose cause was favoured by the most absurd superstitions, and by these only, refused to obey the emperor's commands. The exarch of Ravenna, as a subject of the emperor, was ordered to force the pope to a compliance, and even to seize or assassinate him in case of a refusal. This excited the pious zeal of Luitprand to assist the pope, whom he had formerly designed to subdue: the exarch was first excommunicated, and then torn in pieces by the enraged multitude: the duke of Naples shared the same fate; and a vast number of the *Iconoclasts*, or Image-breakers, as they were called, were slaughtered without mercy: and to complete all, the subjects of the exarchate, at the instigation of the Pope, renounced their allegiance to the emperor.

Leo was no sooner informed of this revolt than he ordered a powerful army to be raised, in order to reduce the rebels, and take vengeance on the Pope. Alarmed at these warlike preparations, Gregory looked round for some power on which he might depend for protection. The Lombards were possessed of sufficient force, but they were too near and too dangerous neighbours to be trusted; the Venetians, though zealous Catholics, were as yet unable to withstand the force of the empire; Spain was overrun by the Saracens: the French seemed, therefore, the only people to whom it was advisable to apply for aid; as they were able to oppose the emperor, and were likewise enemies to his edict. Charles Martel, who at that time governed France as mayor of the palace, was therefore applied to; but before a treaty could be concluded, all the parties concerned were removed by death. Constantine Copronymus, who succeeded Leo at Constantinople, not only persisted in the opposition to image-worship begun by his predecessor, but prohibited also the invocation of saints. Zachary, who succeeded Gregory III. in the pontificate, proved as zealous an adversary as his predecessor. Pepin, who succeeded Charles Martel in the sovereignty of France, proved as powerful a friend to the pope as his father had been. The people of Rome had nothing to fear from Constantinople; and therefore drove out all the emperor's officers. The Lombards, awed by the power of France, for some time allowed the pope to govern in peace the dominions of the exarchate; but in 752, Astolphus king of Lombardy not only reduced the greatest part of the pope's territories, but threatened the city of Rome itself. Upon this an application was made to Pepin, who obliged Astolphus to restore the places he had taken, and gave them to the pope, or, as he said, to St Peter. The Greek emperor to whom they of right belonged, remonstrated to no purpose. The pope from that time became possessed of considerable territories in Italy; which, from the manner of their donation, go under the name of *St Peter's Patrimony*. It was not, however, before the year 774, that the pope was fully secured in these new dominions. This was accomplished when the kingdom of the Lombards was totally destroyed by

by Charlemagne, who was thereupon crowned king of Italy. Soon after this, the monarch made himself master of all the Low Countries, Germany, and part of Hungary; and in the year 800 was solemnly crowned by the pope emperor of the west.

Thus was the world once more divided into three great empires. The empire of the Arabs or Saracens extended from the river Ganges to Spain; comprehending almost all of Asia and Africa which has ever been known to Europeans, the kingdoms of China and Japan excepted. The eastern Roman empire was reduced to Greece, Asia Minor, and the provinces adjoining to Italy. The empire of the west, under Charlemagne, comprehended France, Germany, and the greatest part of Italy. The Saxons, however, as yet possessed Britain unmolested by external enemies, though the seven kingdoms erected by them were engaged in perpetual contests. The Venetians also enjoyed a nominal liberty; though it is probable that their situation would render them very much dependent on the great powers which surrounded them. Of all nations on earth, the Scots and Picts, and the remote ones of China and Japan seem to have enjoyed, from their situation, the greatest share of liberty; unless, perhaps, we except the Scandinavians, who, under the names of *Danes* and *Normans*, were soon to infest their southern neighbours. But of all the European potentates, the popes certainly exercised the greatest authority; since even Charlemagne himself submitted to accept the crown from their hands, and his successors made them the arbiters of their differences.

Matters, however, did not long continue in this state. The empire of Charlemagne was on the death of his son Lewis divided among his three children. Endless disputes and wars ensued among them, till at last the sovereign power was seized by Hugh Capet in 987. The Saxon heptarchy was dissolved in 827, and the whole kingdom of England reduced under one head. The Danes and Normans began to make depredations, and infest the neighbouring states. The former conquered the English Saxons, and seized the government, but were in their turn expelled by the Normans in 1066. In Germany and Italy the greatest disturbances arose from the contests between the popes and the emperors. To all this if we add the internal contests which happened through the ambition of the powerful barons of every kingdom, we can scarce form an idea of times more calamitous than those of which we now treat. All Europe, nay, all the world, was one great field of battle; for the empire of the Mahometans was not in a more settled state than that of the Europeans. Caliphs, sultans, emirs, &c. waged continual war with each other in every quarter; new sovereignties every day sprung up, and were as quickly destroyed. In short, through the ignorance and barbarity with which the whole world was overspread, it seemed in a manner impossible that the human race could long continue to exist; when happily the crusades, by directing the attention of the Europeans to one particular object, made them in some measure suspend their slaughters of one another.

11. The crusades originated from the superstition of the two grand parties into which the world was at that time divided, namely, the Christians and Mahometans. Both looked upon the small territory of Palestine,

VOL. X. Part II.

which they called the *Holy Land*, to be an invaluable acquisition, for which no sum of money could be an equivalent; and both took the most unjustifiable methods to accomplish their desires. The superstition of Omar the second caliph had prompted him to invade this country, part of the territories of the Greek emperor, who was doing him no hurt; and now when it had been so long under the subjection of the Mahometans, a similar superstition prompted the pope to send an army for the recovery of it. The crusaders accordingly poured forth in multitudes, like those with which the kings of Persia formerly invaded Greece; and their fate was pretty similar. Their impetuous valour at first, indeed, carried every thing before them; they recovered all Palestine, Phœnicia, and part of Syria, from the infidels; but their want of conduct soon lost what their valour had obtained, and very few of that vast multitude which had left Europe ever returned to their native countries. A second, a third, and several other crusades, were preached, and were attended with a like success in both respects: vast numbers took the cross, and repaired to the Holy Land; which they polluted with the most abominable massacres and treacheries, and from which very few of them returned. In the third crusade Richard I. of England was embarked, who seems to have been the best general that ever went into the east: but even his valour and skill were not sufficient to repair the faults of his companions; and he was obliged to return even after he had entirely defeated his antagonists, and was within sight of Jerusalem.

But while the Christians and Mahometans were thus surreptitiously contending for a small territory in the western parts of Asia, the nations in the more easterly parts were threatened with total extermination. Jenghiz Khan, the greatest as well as the most bloody conqueror that ever existed, now makes his appearance. The rapidity of his conquests seemed to emulate those of Alexander the Great; and the cruelties he committed were altogether unparalleled. It is worth observing, that Jenghiz Khan and all his followers were neither Christians nor Mahometans, but strict deists. For a long time even the sovereign had not heard of a temple, or any particular place on earth appropriated by the deity to himself, and treated the notion with ridicule when it was first mentioned to him.

The Moguls, over whom Jenghiz Khan assumed the sovereignty, were a people of East Tartary, divided into a great number of petty governments as they are at this day, but who owned a subjection to one sovereign, whom they called *Vang Khan*, or the Great Khan. Temujin, afterwards *Jenghiz Khan*, was one of these petty princes; but unjustly deprived of the greatest part of his inheritance at the age of 13, which he could not recover till he arrived at that of 40. This corresponds with the year 1201, when he totally reduced the rebels; and as a specimen of his lenity caused 70 of their chiefs to be thrown into as many caldrons of boiling water. In 1202, he defeated and killed Vang Khan himself (known to the Europeans by the name of *Prester John of Asia*); and possessing himself of his vast dominions, became from thenceforward altogether irresistible. In 1206, having still continued to enlarge his dominions, he was declared khan of the Moguls and

3 U

Tartars;

Civil
History.

Tartars; and took upon him the title of *Jenghiz Khan*, or *The most Great Khan of khans*. This was followed by the reduction of the kingdom of Hya in China, Tangut, Kitay, Turkestan, Karazm (the kingdom of Gazna founded by Mahmud Gazni), Great Bukharia, Persia, and part of India; and all these vast regions were reduced in 26 years. The devastations and slaughters with which they were accomplished are unparalleled, no fewer than 14,470,000 persons being computed to have been massacred by Jenghiz Khan during the last 22 years of his reign. In the beginning of 1227 he died, thereby freeing the world from a most bloody tyrant. His successors completed the conquest of China and Korea; but were foiled in their attempts on Cochin-China, Tong-king, and Japan. On the western side the Tartar dominions were not much enlarged till the time of Hulaku, who conquered Media, Babylonia, Mesopotamia, Assyria, Syria, Georgia, Armenia, and almost all Asia Minor; putting an end to the empire of the Saracens by the taking of Bagdad in 1258.

The empire of Jenghiz Khan had the fate of all others. Being far too extensive to be governed by one head, it split into a multitude of small kingdoms, as it had been before his time. All these princes, however, owned allegiance to the family of Jenghiz Khan till the time of Timur Bek, or Tamerlane. The Turks, in the mean time, urged forward by the inundation of Tartars who poured in from the east, were forced upon the remains of the Greek empire; and at the time of Tamerlane above mentioned, they had almost confined this once mighty empire within the walls of Constantinople.

48
Of Tamer-
lane.

In the year 1335, the family of Jenghiz Khan becoming extinct in Persia, a long civil war ensued; during which Timur Bek, one of the petty princes among which the Tartar dominions were divided, found means to aggrandize himself in a manner similar to what Jenghiz Khan had done about 150 years before. Jenghiz Khan, indeed, was the model whom he proposed to imitate; but it must be allowed that Timur was more merciful than Jenghiz Khan, if indeed the word can be applied to such inhuman tyrants. The plan on which Jenghiz Khan conducted his expeditions was that of total extermination. For some time he utterly extirpated the inhabitants of those places which he conquered, designing to people them anew with his Moguls; and in consequence of this resolution, he would employ his army in beheading 100,000 prisoners at once. Timur's cruelty, on the other hand, seldom went farther than the pounding of 3000 or 4000 people in large mortars, or building them among bricks and mortar into a wall. We must observe, however, that Timur was not a deist, but a Mahometan, and conquered expressly for the purpose of spreading the Mahometan religion; for the Moguls had now adopted all the superstitions and absurdities of Mahomet. Thus was all the eastern quarter of the world threatened anew with the most dreadful devastations, while the western nations were exhausting themselves in fruitless attempts to regain the Holy Land. The Turks were the only people who seem at this period to have been gathering strength, and by their perpetual encroachments threatened to swallow up the

western nations as the Tartars had done the eastern ones.

Civil
History.

In 1362, Timur invaded Bukharia, which he reduced in five years. He proceeded in his conquests, though not with the same celerity as Jenghiz Khan, till the year 1387, when he had subdued all Persia, Armenia, Georgia, Karazm, and great part of Tartary. After this he proceeded westward, subduing all the countries to the Euphrates; made himself master of Bagdad; and even entered Russia, where he pillaged the city of Moscow. From thence he turned his arms to the east, and totally subdued India. In 1393, he invaded and reduced Syria; and having turned his arms against the Turks, forced their sultan Bajazet to raise the siege of Constantinople. This brought on an engagement, in which Bajazet was entirely defeated and taken prisoner; which broke the power of the Turks to such a degree, that they were not for some time able to recover themselves. At last this great conqueror died in the year 1405, while on his way to conquer China, as Jenghiz Khan had done before him.

The death of Timur was followed almost immediately by the dissolution of his empire. Most of the nations he had conquered recovered their liberty. ⁴⁹ State of the world since that time.

The Turks had now no further obstacle to their conquest of Constantinople. The western nations having exhausted themselves in the *holy wars*, as they were called, had lost that insatiable thirst after conquest which for so long time possessed the minds of men. They had already made considerable advances in civilization, and began to study the arts of peace. Gunpowder was invented, and its application to the purposes of war already known; and, though no invention threatened to be more destructive, perhaps none was ever more beneficial to the human race. By the use of fire-arms, nations are put more on a level with each other than formerly they were; war is reduced to a regular system, which may be studied with as much success as any other science. Conquests are not now to be made with the same ease as formerly; and hence the last ages of the world have been much more quiet and peaceable than the former ones. In 1453, the conquest of Constantinople by the Turks fixed that wandering people to one place; and though now they possess very large regions both in Europe, Asia, and Africa, an effectual stop hath long been put to their further progress.

About this time, also, learning began to revive in Europe, where it had been long lost; and the invention of printing, which happened about the same time, rendered it in a manner impossible for barbarism ever to take place in such a degree as formerly. All nations of the world, indeed, seem now at once to have laid aside much of their former ferocity; and, though wars have by no means been uncommon, they have not been carried on with such circumstances of fury and savage cruelty as before. Instead of attempting to enrich themselves by plunder, and the spoils of their neighbours, mankind in general have applied themselves to commerce, the only true and durable source of riches. This soon produced improvements in navigation; and these improvements led to the discovery of many regions formerly unknown. At the same time, the European

European powers, being at last thoroughly sensible that extensive conquests could never be permanent, applied themselves more to provide for the security of those dominions which they already possessed, than to attempt the conquest of one another: and this produced the policy to which so much attention was lately paid, namely, the *preserving of the balance of Europe*; that is, preventing any one of the nations from acquiring sufficient strength to overpower another.

In the end of the 15th century, the vast continent of America was discovered; and, almost at the same time, the passage to the East Indies by the Cape of Good Hope. The discovery of these rich countries gave a new turn to the ambition of the Europeans. To enrich themselves either by the gold and silver produced in these countries, or by traffic with the natives, now became the object. The Portuguese had the advantage of being the first discoverers of the eastern, and the Spaniards of the western countries. The former did not neglect so favourable an opportunity of enriching themselves by commerce. Many settlements were formed by them in the East India islands, and on the continent; but their avarice and perfidious behaviour towards the natives proved at last the cause of their total expulsion. The Spaniards enriched themselves by the vast quantities of the precious metals imported from America, which were not obtained but by the most horrid massacres committed on the natives, and of which an account is given under the different names of the American countries. These possessions of the Spaniards and Portuguese soon excited other European nations to make attempts to share with them in their treasures, by planting colonies in different parts of America, and making settlements in the East Indies: and thus has the rage of war in some measure been transferred from Europe to these distant regions; and, after various contests, the British at last obtained a great superiority both in America and the East Indies.

In Europe the only considerable revolutions which happened during this period, were, The total expulsion of the Moors and Saracens from Spain, by the taking of Granada in 1491; the union of the kingdoms of Arragon and Castile, by the marriage of Ferdinand and Isabella; and the revolt of the states of Holland from the Spaniards. After much contention and bloodshed, these last obtained their liberty, and were declared a free people in 1609; since which time they have continued an independent and very considerable nation of Europe.

In Asia nothing of importance hath happened since the taking of Constantinople by the Turks. That continent is now divided among the following nations. The most northerly part, called *Siberia*, extending to the very extremity of the continent, is under the power of Russia. To the southward, from Asia Minor to China and Korea, are the Tartars, formidable indeed from their numbers, but, by reason of their barbarity and want of union, incapable of attempting any thing. The Turks possess the western part of the continent, called *Asia Minor*, to the river Euphrates. The Arabs are again confined within their own peninsula; which they possess, as they have ever done, without owning subjection to any foreign power. To the east of Turkey in Asia lies Persia, now more confined in its limits than before; and to the eastward of

Persia lies India, or the kingdom late of the Mogul, comprehending all the country from the Indus to the Ganges, and beyond that river. Still farther to the east lie the kingdoms of Siam, Pegu, Thibet, and Cochin-China, little known to the Europeans. The vast empire of China occupies the most easterly part of the continent; while that of Japan comprehends the islands which go by that name, and which are supposed to lie at no great distance from the western coasts of America.

In Africa the Turks possess Egypt, which they conquered in 1517, and have a nominal jurisdiction over the states of Barbary. The interior parts are filled with barbarous and unknown nations, as they have always been. On the western coasts are many settlements of the European nations, particularly the British and Portuguese; and the southern extremity is possessed by the Dutch. The eastern coasts are almost totally unknown. The Asiatic and African islands are either possessed by the Europeans, or inhabited by savage nations.

The European nations at the beginning of the 17th century were Sweden, Muscovy, Denmark, Poland, Britain, Germany, Holland, France, Spain, Portugal, Italy, and Turkey in Europe. Of these the Russians, though the most barbarous, were by far the most considerable, both in regard to numbers and the extent of their empire; but their situation made them little feared by the others, who lay at a distance from them. The kingdom of Poland, which was first set up in the year 1000, proved a barrier between Russia and Germany; and at the same time the policy above mentioned, of keeping up the balance of power in Europe, rendered it probable that no one European nation, whatever wars it might be engaged in, would have been totally destroyed, or ceased to exist as a distinct kingdom. The late dismemberment of Poland, however, or its partition between the three powers Russia, Hungary, and Prussia, was a step very inconsistent with the above political system; and it is surprising with what tameness it was acquiesced in by the other powers. Subsequent circumstances, particularly the passiveness with which the ambitious designs of Russia against the Porte have been so long beheld, seem to indicate a total dereliction of that scheme of equilibrium, formerly so wisely, though perhaps sometimes too anxiously, attended to.

The revolt of the British colonies in America, it was hoped by the enemies of Britain, would have given a fatal shock to her strength and wonted superiority. The consequences, however, have been very different. These colonies, it is true, have been disjoined from the mother-country, and have attained an independent rank among the nations. But Britain has had no cause to repine at the separation. Divested only of a splendid encumbrance, an expensive and invidious appanage, she has been left to enjoy the undivided benefits of her native vigour, and to display new energies, which promise her mild empire a long and prosperous duration. On the other hand, it has been said, the flame which was to have blazed only to her prejudice, has brought confusion on her chief foe; and the ambition and tyranny of that branch of the house of Bourbon which has been long the pest of Europe, now lie humbled in the dust. The French, indeed, have thus become a nation

Ecclesiastical
History.

of freemen as well as ourselves, and as well as the Americans; who, by the way, were never otherwise, nor ever knew what oppression was except in inflicting it upon their African brethren. But neither is the French revolution an event which Britons, as lovers of liberty and friends to the rights of mankind, should regret; or which, even in a political view, if duly considered, ought to excite either their jealousy or apprehension. The papal power, too, is declining; and the period seems to be approaching when the Roman pontiff will be reduced to his original title of *bishop of Rome*. Such was the language held for some years during the progress of the French revolution. But the extraordinary events which have since occurred, have totally changed the views and sentiments of mankind. The fair prospect of liberty which the friends of humanity hoped had begun to dawn on France, has quite vanished; and unfortunately the most powerful despot, as well as the most capricious tyrant, has seated himself on the throne of her ancient kings. The prediction with regard to the pope was more than verified by this usurper, at whose nod the head of the catholic church holds his authority; and at this moment (December 1806) the continent of Europe seems to be threatened with universal subjugation to the same restless and ambitious power.

SECT. II. Ecclesiastical History.

50
Revolutions in religion seldom happen.

THE history of religion, among all the different nations that have existed in the world, is a subject no less important and interesting than that of civil history. It is, however, less fertile of great events, affords an account of fewer revolutions, and is much more uniform, than civil history. The reason of this is plain. Religion is conversant about things which cannot be seen, and which of consequence cannot suddenly and strongly affect the senses of mankind, as natural things are apt to do. The expectation of worldly riches can easily induce one nation to attack another; but it is not easy to find any thing which will induce a nation to change its religion. The invisible nature of spiritual things, the prejudice of habit and of early education, all stand in the way of changes of this kind. Hence the revolutions in religion have been but few, and the duration of almost any religion of longer standing than the most celebrated empires; the changes which have happened, in general, have required a long time to bring them about, and history scarce affords an instance of the religion of any nation being essentially and suddenly changed for another.

With regard to the origin of religion, we must have recourse to the Scriptures; and are as necessarily constrained to adopt the account there given, as we are to adopt that of the creation given in the same book; namely, because no other hath made its appearance which seems in any degree rational, or consistent with itself.—In what manner the true religion given to Adam was falsified or corrupted by his descendants before the flood, doth not clearly appear from Scripture. Idolatry is not mentioned; nevertheless we are assured that the inhabitants of the world were then exceedingly wicked; and as their wickedness did not consist in worshipping false gods, it may be concluded that they worshipped none at all; i. e. that the crime of the antediluvians was deism or atheism.

5

After the flood, idolatry quickly made its appearance; but what gave rise to it is not certainly known. This superstition indeed seems to be natural to man, especially when placed in such a situation that he hath little opportunity of instruction, or of improving his rational faculties. This seems also probable from a caution given to the Jews, lest, when they looked up to the sun, moon, and stars, and the rest of the host of heaven, they should be *driven to worship them*. The origin of idolatry among the Syrians and Arabians, and also in Greece, is therefore accounted for with great probability in the following manner by the author of the Ruins of Balbeck. "In those uncomfortable deserts, where the day presents nothing to the view but the uniform, tedious, and melancholy prospect of barren sands, the night discloses a most delightful and magnificent spectacle, and appears arrayed with charms of the most attractive kind. For the most part unclouded and serene, it exhibits to the wondering eye the host of heaven in all their variety and glory. In the view of this stupendous scene, the transition from admiration to idolatry was too easy to uninstructed minds; and a people whose climate offered no beauties to contemplate but those of the firmament, would naturally look thither for the objects of their worship. The form of idolatry in Greece was different from that of the Syrians; which perhaps may be attributed to that smiling and variegated scene of mountains, valleys, rivers, woods, groves, and fountains, which the transported imagination, in the midst of its pleasing astonishment, supposed to be the seats of invisible deities."

Ecclesiastical
History.
51
Origin of
idolatry.

A difficulty, however, arises on this supposition; for if idolatry is naturally produced in the mind of uninstructed and savage man from a view of the creation, why hath not idolatry of some kind or other taken place among all the different nations of the world? This certainly hath not been the case; of which the most striking examples are the Persians of old, and the Moguls in more modern times. Both these nations were strict deists; so that we must allow some other causes to concur in producing idolatry besides these already mentioned; and of these causes an imperfect and obscure notion of the true religion seems to be the most probable.

Though idolatry, therefore, was formerly very prevalent, it neither extended over the whole earth, nor were the superstitions of the idolaters all of one kind. Every nation had its respective gods, over which one more excellent than the rest was said to preside; yet in such a manner, that this supreme deity himself was controuled by the rigid empire of the fates, or by what philosophers called *eternal necessity*. The gods of the east were different from those of the Gauls, the Germans, and the other northern nations. The Grecian divinities differed widely from those of the Egyptians, who deified plants, animals, and a great variety of the productions both of nature and art. Each people also had their own particular manner of worshipping and appeasing their respective deities, entirely different from the sacred rites of other countries. All this variety of religions, however, produced neither wars nor dissensions among the different nations; each nation suffered its neighbours to follow their own method of worship, without discovering any displeasure on that account.

There

Ecclesiastical history.

There is nothing surprising in this mutual toleration, when we consider, that they all looked upon the world as one great empire, divided into various provinces, over each of which a certain order of divinities presided; for which reason they imagined that none could behold with contempt the gods of other nations, or force strangers to pay homage to theirs.—The Romans exercised this toleration in the most ample manner; for though they would not allow any change to be made in the religions that were publicly professed in the empire, nor any new form of worship to be openly introduced, yet they granted to their citizens a full liberty of observing in private the sacred rites of other nations, and of honouring foreign deities as they thought proper.

The heathen deities were honoured with rites and sacrifices of various kinds, according to their respective natures and offices. Their rites were absurd and ridiculous; while the priests, appointed to preside over this strange worship, abused their authority, by deceiving and imposing upon the people in the grossest manner.

53
state of religion at the appearance of Christ.

From the time of the flood to the coming of Christ, idolatry prevailed among almost all the nations of the world, the Jews alone excepted; and even they were on all occasions ready to run into it, as is evident from their history in the Old Testament. At the time of Christ's appearance, the religion of the Romans, as well as their empire, extended over a great part of the world. Some people there were among the heathens who perceived the absurdities of that system; but being destitute of means, as well as of abilities, to effect a reformation, matters went on in their old way. Though there were at that time various sects of philosophers, yet all of them proceeded upon false principles, and consequently could be of no service to the advancement or reformation of religion. Nay, some, among whom were the Epicureans and Academics, declared openly against every kind of religion whatever.

Two religions at this time flourished in Palestine, viz. the Jewish and Samaritan; between whose respective followers reigned the most violent hatred or contempt. The difference between them seems to have been chiefly about the place of worship; which the Jews would have to be in Jerusalem, and the Samaritans on Mount Gerizzim. But though the Jews were certainly right as to this point, they had greatly corrupted their religion in other respects. They expected a Saviour indeed, but they mistook his character; imagining that he was to be a powerful and warlike prince, who should set them free from the Roman yoke, which they bore with the utmost impatience. They also imagined that the whole of religion consisted in observing the rites of Moses, and some others which they had added to them, without the least regard to what is commonly called *morality* or *virtue*; as is evident from the many charges our Saviour brings against the Pharisees, who had the greatest reputation for sanctity among the whole nation. To these corrupt and vicious principles, they added several absurd and superstitious notions concerning the divine nature, invisible powers, magic, &c. which they had partly imbibed during the Babylonian captivity, and partly derived from their neighbours in Arabia, Syria and Egypt. The principal sects among them

were the **ESSENES** or **Essenians**, **PHARISEES**, and **SADDUCEES**. The Samaritans, according to the most general opinion, had corrupted their religion still more than the Jews.

Ecclesiastical History.

When the true religion was preached by the Saviour of mankind, it is not to be wondered at if he became on that account obnoxious to a people so deeply sunk in corruption and ignorance as the Jews then were. It is not here requisite to enter into the particulars of the doctrine advanced by him, or of the opposition he met with from the Jews; as a full account of these things, and likewise of the preaching of the gospel by the apostles, may be found in the New Testament.—The rapid progress of the Christian religion, under these faithful and inspired ministers, soon alarmed the Jews, and raised various persecutions against its followers. The Jews, indeed, seem at first to have been everywhere the chief promoters of persecution; for we find that they officiously went from place to place, wherever they heard of the increase of the gospel, and by their calumnies and false suggestions endeavoured to excite the people against the apostles. The Heathens, however, though at first they showed no very violent spirit of persecution against the Christians, soon came to hate them as much as the Jews themselves. Tacitus acquaints us with the causes of this hatred, when speaking of the first general persecution under Nero. That inhuman emperor having, as was supposed, set fire to the city of Rome, to avoid the imputation of this wickedness, transferred it on the Christians. Our author informs us that they were already abhorred on account of their many and enormous crimes. "The author of this name (*Christians*)," says he "was **CHRIST**, who, in the reign of Tiberius, was executed under Pontius Pilate, procurator of Judæa. The pestilent superstition was for a while suppressed: but it revived again, and spread, not only over Judæa, where this evil was first broached, but reached Rome, whither from every quarter of the earth is constantly flowing whatever is hideous and abominable amongst men, and is there readily embraced and practised. First, therefore, were apprehended such as openly avowed themselves to be of that sect; then by them were discovered an immense multitude; and all were convicted, not of the crime of burning Rome, but of hatred and enmity to mankind. Their death and tortures were aggravated by cruel derision and sport; for they were either covered with the skins of wild beasts and torn in pieces by devouring dogs, or fastened to crosses, or wrapped up in combustible garments, that, when the day-light failed, they might, like torches, serve to dispel the darkness of the night. Hence, towards the miserable sufferers, however guilty and deserving the most exemplary punishment, compassion arose; seeing they were doomed to perish not with a view to the public good; but to gratify the cruelty of one man."

54
Tacitus's account of the first persecution by Nero.

That this account of Tacitus is downright misrepresentation and calumny, must be evident to every one who reads it. It is impossible that any person can be convicted of hatred and enmity to mankind, without specifying a number of facts by which this hatred showed itself. The burning of Rome would indeed have been a very plain indication of enmity to mankind; but of this Tacitus himself clears them, and

Ecclesiastical History.

and mentions no other crime of which they were guilty. It is probable, therefore, that the only reason of this charge against the Christians, was their absolute refusal to have any share in the Roman worship, or to countenance the absurd superstitions of Paganism in any degree.

55 Second persecution.

The persecution under Nero was succeeded by another under Domitian; during which the apostle John was banished to Patmos, where he saw the visions, and wrote the book called his *Revelation*, which completes the canon of Scripture. This persecution commenced in the 95th year of the Christian era; and John is supposed to have written his *Revelation* the year after, or in the following one.

During the first century, the Christian religion spread over a great number of different countries; but as we have now no authentic records concerning the travels of the apostles, or the success which attended them in their ministry, it is impossible to determine how far the gospel was carried during this period. We are, however, assured, that even during this early period many corruptions were creeping in, the progress of which was with difficulty prevented even by the apostles themselves. Some corrupted their profession by a mixture of Judaism, others by mixing it with the oriental philosophy; while others were already attempting to deprive their brethren of liberty, setting themselves up as eminent pastors, in opposition even to the apostles, as we learn from the epistles of St Paul, and the third epistle of St John. Hence arose the sects of the Gnostics, Cerinthians, Nicolaitans, Nazarenes, Ebionites, &c. with which the church was troubled during this century.

Concerning the ceremonies and method of worship used by the Christians of the first century, it is impossible to say any thing with certainty. Neither is the church order, government, and discipline, during this period, ascertained with any degree of exactness. Each of those parties, therefore, which exist at this day, contends with the greatest earnestness for that particular mode of worship which they themselves have adopted; and some of the most bigotted would willingly monopolize the word *church* in such a manner as to exclude from all hope of salvation every one who is not attached to their particular party. It doth not however appear that, excepting baptism, the Lord's supper, and anointing the sick with oil, any external ceremonies or symbols were properly of divine appointment. According to Dr Mosheim, "there are several circumstances which incline us to think, that the friends and apostles of our blessed Lord either tolerated through necessity, or appointed for wise reasons, many other external rites in various places. At the same time, we are not to imagine, that they ever conferred upon any person a perpetual, indelible, pontifical authority, or that they enjoined the same rites in all churches. We learn, on the contrary, from authentic records, that the Christian worship was from the beginning celebrated in a different manner in different places; and that, no doubt, by the orders, or at least with the approbation, of the apostles and their disciples. In those early times, it was both wise and necessary to show, in the establishment of outward forms of worship, some indulgence to the ancient opinions,

manners, and laws, of the respective nations to whom the gospel was preached."

Ecclesiastical History.

The second century commences with the third year of the emperor Trajan. The Christians were still persecuted; but as the Roman emperors were for the most part of this century princes of a mild and moderate turn, they persecuted less violently than formerly. Marcus Aurelius, notwithstanding the clemency and philosophy for which he is so much celebrated, treated the Christians worse than Trajan, Adrian, or even Severus himself did, who was noted for his cruelty. This respite from vigorous persecution proved a very favourable circumstance for the spreading of the Christian religion; yet it is by no means easy to point out the particular countries through which it was diffused. We are, however, assured, that in the second century, Christ was worshipped as God almost through the whole east; as also among the Germans, Spaniards, Celtes, and many other nations: but which of them received the gospel in the first century, and which in the second, is a question unanswerable at this distance of time. The writers of this century attribute the rapid progress of Christianity chiefly to the extraordinary gifts that were imparted to the first Christians, and the miracles which were wrought at their command; without supposing that any part of the success ought to be ascribed to the intervention of human means, or secondary causes. Many of the moderns, however, are so far from being of this opinion, that they are willing either to deny the authenticity of all miracles said to have been wrought since the days of the apostles, or to ascribe them to the power of the devil. To enter into the particulars of this controversy is foreign to our present purpose; for which reason we must refer to the writers of polemic divinity, who have largely treated of this and other points of a similar nature.

56 History of the second century.

The corruptions which had been introduced in the first century, and which were almost coeval with Christianity itself, continued to gain ground in the second. Ceremonies, in themselves futile and useless, but which must be considered as highly pernicious when joined to a religion incapable of any other ornament than the upright and virtuous conduct of its professors, were multiplied for no other purpose than to please the ignorant multitude. The immediate consequence of this was, that the attention of Christians was drawn aside from the important duties of morality; and they were led to imagine, that a careful observance of the ceremonies might make amends for the neglect of moral duties. This was the most pernicious opinion that could possibly be entertained; and was indeed the very foundation of that enormous system of ecclesiastical power which afterwards took place, and held the whole world in slavery and barbarism for many ages.

57 Ceremonies multiplied.

Another mischief was the introduction of *mysteries*, as they were called, into the Christian religion; that is, insinuating that some parts of the worship in common use had a hidden efficacy and power far superior to the plain and obvious meaning assigned to them by the vulgar: and by paying peculiar respect to these mysteries, the pretended teachers of the religion of Jesus accommodated their doctrines to the taste of their heathen neighbours, whose religion consisted in a heap of mysteries, of which nobody knew the meaning.

58 Mysteries introduced.

By

colonia-
vital
History

59
e teach-
assume
lower
it the
ple.

60
rn of
web go-
nment.

61
ages
dhood
the in-
ation of
cells.

By these, and other means of a similar kind, the Christian pastors greatly abridged the liberty of their flocks. Being masters of the ceremonies and mysteries of the Christian religion, they had it in their power to make their followers worship and believe whatever they thought proper; and this they did not fail to make use of for their own advantage. They persuaded the people, that the ministers of the Christian church succeeded to the character, rights, and privileges, of the Jewish priesthood; and accordingly the bishops considered themselves as invested with a rank and character similar to those of the high-priest among the Jews, while the presbyters represented the priests, and the deacons the Levites. This notion, which was first introduced in the reign of Adrian, proved a source of very considerable honour and profit to the clergy.

The form of ecclesiastical government was in this century rendered permanent and uniform. One inspector or bishop presided over each Christian assembly, to which office he was elected by the voices of the whole people. To assist him in his office, he formed a council of presbyters, which was not confined to any stated number. To the bishops and presbyters the ministers or *deacons* were subject; and the latter were divided into a variety of classes, as the different exigencies of the church required. During a great part of this century, the churches were independent of each other; nor were they joined together by association, confederacy, or any other bonds but those of charity. Each assembly was a little state governed by its own laws, which were either enacted, or at least approved of, by the society. But in process of time all the Christian churches of a province were formed into one large ecclesiastical body, which, like confederate states, assembled at certain times, in order to deliberate about the common interests of the whole. This institution had its origin among the Greeks; but in a short time it became universal, and similar assemblies were formed in all places where the gospel had been planted. These assemblies, which consisted of the deputies or commissioners from several churches, were called *synods* by the Greeks, and *councils* by the Latins; and the laws enacted in these general meetings were called *canons*, i. e. *rules*.

These councils, of which we find not the smallest trace before the middle of this century, changed the whole face of the church, and gave it a new form; for by them the ancient privileges of the people were considerably diminished, and the power and authority of the bishops greatly augmented. The humility, indeed, and prudence, of these pious prelates hindered them from assuming all at once the power with which they were afterwards invested. At their first appearance in these general councils, they acknowledged that they were no more than the delegates of their respective churches, and that they acted in the name and by the appointment of their people. But they soon changed this humble tone; imperceptibly extended the limits of their authority; turned their influence into dominion, their counsels into laws; and at length openly asserted, that Christ had empowered them to prescribe to his people *authoritative rules of faith and manners*. Another effect of these councils was the gradual abolition of that perfect equality which reigned among all bishops in the primitive times; for the order and de-

ceuty of these assemblies required, that some one of the provincial bishops met in council should be invested with a superior degree of power and authority; and hence the rights of metropolitans derive their origin. In the mean time, the bounds of the church were enlarged; the custom of holding councils was followed wherever the sound of the gospel had reached; and the universal church had now the appearance of one vast republic formed by a combination of a great number of little states. This occasioned the creation of a new order of ecclesiastics, who were appointed in different parts of the world as heads of the church, and whose office it was to preserve the consistence and union of that immense body, whose members were so widely dispersed throughout the nations. Such was the nature and office of the *Patriarchs*; among whom, at length, ambition, being arrived at its most insolent period, formed a new dignity, investing the bishop of Rome with the title and authority of the *Prince of the Patriarchs*.

During the second century, all the sects continued which had sprung up in the first, with the addition of several others; the most remarkable of which were the *Ascetics*. These owed their rise to an error propagated by some doctors of the church, who asserted that Christ had established a *double rule of sanctity and virtue* for two different orders of Christians. Of these rules, one was ordinary, the other extraordinary; the one of a lower dignity, the other more sublime; the first for persons in the active scenes of life; the other for those who, in a sacred retreat, aspired after the glory of a celestial state. In consequence of this system, they divided into two parts all those moral doctrines and instructions which they had received either by writing or tradition. One of these divisions they called *precepts*, and the other *counsels*. They gave the name of *precepts* to those laws that were universally obligatory upon all orders of men; and that of *counsels* to those which related to Christians of a more sublime rank, who proposed to themselves great and glorious ends, and breathed after an intimate communion with the Supreme Being.—Thus were produced all at once a new set of men, who made pretensions to uncommon sanctity and virtue, and declared their resolution of obeying all the *precepts* and *counsels* of Christ, in order to their enjoyment and communion with God here, and also that, after the dissolution of their mortal bodies, they might ascend to him with the greater facility, and find nothing to retard their approach to the centre of happiness and perfection. They looked upon themselves as prohibited from the use of things which it was lawful for other Christians to enjoy; such as wine, flesh, matrimony, and commerce. They thought it their indispensable duty to extenuate their body by watchings, abstinence, labour, and hunger. They looked for felicity in solitary retreats, and desert places; where, by severe and assiduous efforts of sublime meditation, they raised the soul above all external objects, and all sensual pleasures. They were distinguished from other Christians, not only by the titles of *Ascetics*, *Συδαίται*, *Εκλωνοί*, and philosophers, but also by their garb. In this century, indeed, those who embraced such an austere kind of life, submitted themselves to all these mortifications in private, without breaking asunder their social bands, or withdrawing themselves

Ecclesia-
stical
History.

62
Account of
the Acco-
ntics.

themselves from mankind; but in process of time they retired into deserts, and, after the example of the Esenes and Therapeutæ, they formed themselves into certain companies.

This austere sect arose from an opinion which has been more or less prevalent in all ages and in all countries, namely, that religion consists more in prayers, meditations, and a kind of secret intercourse with God, than in fulfilling the social duties of life in acts of benevolence and humanity to mankind. Nothing can be more evident than that the Scripture reckons the fulfilling of these infinitely superior to the observance of all the ceremonies that can be imagined: yet it somehow or other happens, that almost every body is more inclined to observe the ceremonial part of devotion than the moral; and hence, according to the different humours or constitutions of different persons, there have been numberless forms of Christianity, and the most virulent contentions among those who professed themselves followers of the Prince of Peace. It is obvious, that if the moral conduct of Christians was to be made the standard of faith, instead of speculative opinions, all these divisions must cease in a moment; but while Christianity, or any part of it, is made to consist in speculation, or the observance of ceremonies, it is impossible there can be any end of sects or heresies. No opinion whatever is so absurd, but some people have pretended to argue in its defence; and no ceremony so insignificant, but it hath been explained and sanctified by hot-headed enthusiasts; and hence ceremonies, sects, and absurdities, have been multiplied without number, to the prejudice of society and of the Christian religion. This short relation of the rise of the Ascetic sect will also serve to account for the rise of any other; so that we apprehend it is needless to enter into particulars concerning the rest, as they all took their origin from the same general principle variously modified, according to the different dispositions of mankind.

The Ascetic sect began first in Egypt, from whence it passed into Syria and the neighbouring countries. At length it reached the European nations: and hence that train of austere and superstitious vows and rites which totally obscured, or rather annihilated, Christianity; the celibacy of the clergy, and many other absurdities of the like kind. The errors of the Ascetics, however, did not stop here: In compliance with the doctrines of some Pagan philosophers, they affirmed, that it was not only lawful, but even praise-worthy, to deceive, and to use the expedient of a lie, in order to advance the cause of piety and truth; and hence the *pious frauds* for which the church of Rome hath been so notorious, and with which she hath been so often and justly reproached.

As Christians thus deviated more and more from the true practice of their religion, they became more zealous in the external profession of it. Anniversary festivals were celebrated in commemoration of the death and resurrection of Christ, and of the effusion of the Holy Ghost on the apostles. Concerning the days on which these festivals were to be kept, there arose violent contests. The Asiatic churches in general differed in this point from those of Europe; and towards the conclusion of the second century, Victor bishop of Rome took it in his head to force the eastern churches to follow the rules laid down by the western ones.—

This they absolutely refused to comply with: upon which Victor cut them off from communion with the church of Rome; though, by means of the intercession of some prudent people, the difference was made up for the present.

During most of the third century, the Christians were allowed to enjoy their religion, such as it was, without molestation. The emperors Maximinus and Decius, indeed, made them feel all the rigours of a severe persecution; but their reigns were short, and from the death of Decius to the time of Dioclesian the church enjoyed tranquillity. Thus vast multitudes were converted; but, at the same time, the doctrine grew daily more corrupt, and the lives of professed Christians more wicked and scandalous. New ceremonies were invented in great numbers, and an unaccountable passion now prevailed for the oriental superstitions concerning demons, whence proceeded the whole train of exorcisms, spells, and fears for the apparition of evil spirits, which to this day are nowhere eradicated. Hence also the custom of avoiding all connections with those who were not baptized, or who lay under the penalty of excommunication, as persons supposed to be under the dominion of some evil spirit. And hence the rigour and severity of that discipline and penance imposed upon those who had incurred, by their immoralities, the censure of the church. Several alterations were now made in the manner of celebrating the Lord's supper. The prayers used on this occasion were lengthened, and the solemnity and pomp with which it was attended were considerably increased. Gold and silver vessels were used in the celebration; it was thought essential to salvation, and for that reason administered even to infants. Baptism was celebrated twice a-year to such as, after a long course of trial and preparations, offered themselves candidates. The remission of sins was thought to be its immediate consequence; while the bishop, by prayer and imposition of hands, was supposed to confer those sanctifying gifts of the Holy Ghost that were necessary to a life of righteousness and virtue. An evil demon was supposed naturally to reside in every person, who was the author and source of all the corrupt dispositions and unrighteous actions of that person. The driving out of this demon was therefore an essential requisite for baptism; and in consequence of this opinion, the baptized persons returned home clothed in white garments, and adorned with crowns, as sacred emblems, the former of their inward purity and innocence, and the latter of their victory over sin and the world.— Fasting began now to be held in more esteem than formerly. A high degree of sanctity was attributed to this practice; it was even looked upon as indispensably necessary, from a notion that the demons directed their force chiefly against those who pampered themselves with delicious fare, and were less troublesome to the lean and hungry who lived under the severities of a rigorous abstinence.—The sign of the cross also was supposed to administer a victorious power over all sorts of trials and calamities; and was more especially considered as the surest defence against the snares and stratagems of malignant spirits; for which reason, no Christian undertook any thing of moment, without arming himself, as he imagined, with the power of this triumphant sign. The heresies which troubled the

ecclia-
stical
history.Ecclia-
stical
History.

the church during this century, were the Gnostics, (whose doctrines were new-modelled and improved by Manes, from whom they were afterwards chiefly called *Manicheans*), the Hieracites, Noetians, Sabelians, and Novatians; for a particular account of which, see these articles.

65
nth cen-
r.

The fourth century is remarkable for the establishment of Christianity by law in the Roman empire; which, however, did not take place till the year 324. In the beginning of the century, the empire was governed by four chiefs, viz. Dioclesian, Maximian, Constantius Chlorus, and Galerius, under whom the church enjoyed a perfect toleration. Dioclesian, though much addicted to superstition, had no ill-will against the Christians; and Constantius Chlorus, having abandoned polytheism, treated them with condescension and benevolence. This alarmed the Pagan priests, whose interests were so closely connected with the continuance of the ancient superstitions; and who apprehended, not without reason, that the Christian religion would at length prevail throughout the empire. To prevent the downfall of the Pagan superstition, therefore, they applied to Dioclesian and Galerius Cæsar, by whom a most bloody persecution was commenced in the year 303, and continued till 311. An asylum, however, was opened for the Christians in the year 304. Galerius having dethroned Dioclesian and Maximian, declared himself emperor in the east; leaving all the western provinces, to which great numbers of Christians resorted to avoid the cruelty of the former, to Constantius Chlorus. At length Galerius being overtaken with an incurable and dreadful disease, published an edict ordering the persecution to cease, and restoring freedom to the Christians, whom he had most inhumanly oppressed for eight years. Galerius died the same year; and in a short time after, when Constantine the Great ascended the throne, the Christians were freed from any farther uneasiness, by his abrogating all the penal laws against them; and afterwards issuing edicts, by which no other religion than the Christian was tolerated throughout the empire.

66
ristian-
y esta-
blished by
new-an-
t.67
rence of
corrup-
is.

This event, however, so favourable to the outward peace of the church, was far from promoting its internal harmony, or the reformation of its leaders. The clergy, who had all this time been augmenting their power at the expence of the liberty of the people, now set no bounds to their ambition. The bishop of Rome, was the first in rank, and distinguished by a sort of pre-eminence above the rest of the prelates. He surpassed all his brethren in the magnificence and splendour of the church over which he presided, in the riches of his revenues and possessions, in the number and variety of his ministers, in his credit with the people, and in his sumptuous and splendid manner of living. Hence it happened, that when a new pontiff was to be chosen by the presbyters and people, the city of Rome was generally agitated with dissensions, tumults, and cabals, which often produced fatal consequences. The intrigues and disturbances which prevailed in that city in the year 366, when, upon the death of Liberius, another pontiff was to be chosen in his place, are a sufficient proof of what we have advanced. Upon that occasion, one faction elected Damasus to that high dignity; while the opposite party

these Ursicinus, a deacon of the vacant church, to succeed Liberius. This double election gave rise to a dangerous schism, and to a sort of civil war within the city of Rome; which was carried on with the utmost barbarity and fury, and produced the most cruel massacres and desolations. The inhuman contest ended in the victory of Damasus; but whether his cause was more just than that of Ursicinus, is not so easily determined.

Notwithstanding the pomp and splendour which surrounded the Roman see, it is certain that the bishops of Rome had not yet acquired that pre-eminence of power and jurisdiction which they afterwards enjoyed. In the ecclesiastical commonwealth, indeed, they were the most eminent order of citizens; but still they were citizens as well as their brethren, and subject, like them, to the laws and edicts of the emperors. All religious causes of extraordinary importance were examined and determined either by judges appointed by the emperors, or in councils assembled for that purpose; while those of inferior moment were decided in each district by its respective bishop. The ecclesiastical laws were enacted either by the emperor or councils. None of the bishops acknowledged that they derived their authority from the permission and appointment of the bishop of Rome, or that they were created bishops by the favour of the *apostolic see*. On the contrary, they all maintained that they were the ambassadors and ministers of Jesus Christ, and that their authority was derived from above. It must, however, be observed, that even in this century several of those steps were laid by which the bishops of Rome mounted afterwards to the summit of ecclesiastical power and despotism. This happened partly by the imprudence of the emperors, partly by the dexterity of the Roman prelates themselves, and partly by the inconsiderate zeal and precipitate judgment of certain bishops. The imprudence of the emperor, and precipitation of the bishops, were remarkably discovered in the following event, which favoured extremely the ambition of the Roman pontiff. About the year 372, Valentinian enacted a law, empowering the bishop of Rome to examine and judge other bishops, that religious disputes might not be decided by any profane or secular judges. The bishops assembled in council at Rome in 378, not considering the fatal consequences that must arise from this imprudent law both to themselves and to the church, declared their approbation in the strongest terms, and recommended the execution of it in their address to the emperor Gratian. Some think, indeed, that this law empowered the Roman bishop to judge only the bishops within the limits of his jurisdiction; others, that his power was given only for a certain time, and for a particular purpose. This last notion seems the most probable; but still this privilege must have been an excellent instrument in the hands of sacerdotal ambition.

By the removal of the seat of empire to Constanti-
nople, the emperor raised up, in the bishop of this
new metropolis, a formidable opponent to the bishop
of Rome, and a bulwark which threatened a vigorous
opposition to his growing authority. For as the em-
peror, in order to render Constantinople a second
Rome, enriched it with all the rights and privileges,
honours and ornaments, of the ancient capital of the
world;

68
Bishops of
Rome and
Constanti-
nople rival
each other.

world; so its bishop, measuring his own dignity and rank by the magnificence of the new city, and its eminence as the residence of the emperor, assumed an equal degree of dignity with the bishop of Rome, and claimed a superiority over the rest of the episcopal order. Nor did the emperors disapprove of these high pretensions, since they considered their own dignity as connected in a certain measure with that of the bishop of their imperial city. Accordingly, in a council held at Constantinople in the year 381, by the authority of Theodosius the Great, the bishop of that city was, during the absence of the bishop of Alexandria, and against the consent of the Roman prelate, placed by the third canon of that council in the first rank after the bishop of Rome, and consequently above those of Alexandria and Antioch. Nectarius was the first bishop who enjoyed these new honours accumulated upon the see of Constantinople. His successor, the celebrated John Chrysostom, extended still farther the privileges of that see, and submitted to its jurisdiction all Thrace, Asia, and Pontus; nor were the succeeding bishops of that imperial city destitute of a fervent zeal to augment their privileges and extend their dominion. By this unexpected promotion, the most disagreeable effects were produced. The bishops of Alexandria were not only filled with the most inveterate hatred against those of Constantinople, but contention was excited between the bishops of Rome and Constantinople; which, after being carried on for many ages, concluded at last in the separation of the Greek and Latin churches.

69
Form of church government established by Constantine.

Constantine the Great, in order to prevent civil commotions, and to fix his authority on a stable and solid foundation, made several changes not only in the laws of the empire, but also in the form of the Roman government. And as there were many important reasons which induced him to suit the administration of the church to these changes in the civil constitution, this necessarily introduced among the bishops new degrees of eminence and rank. The four bishops, of Rome, Constantinople, Antioch, and Alexandria, were distinguished by a certain degree of pre-eminence over the rest. These four prelates answered to the four prætorian prefects created by Constantine; and it is possible, that even in this century they were distinguished by the Jewish title of *patriarchs*. After these followed the *exarchs*, who had the inspection of several provinces, and answered to the appointment of certain civil officers who bore the same title. In a lower class were the *metropolitans*, who had only the government of one province; under whom were the *archbishops*, whose inspection was confined to certain districts. In this gradation the *bishops* brought up the rear; but the sphere of their authority was not in all places equally extensive; being in some considerably ample, and in others confined within narrow limits. To these various ecclesiastical orders we might add that of the *chorepiscopi*, or superintendents of the country churches; but this last order was in most places suppressed by the bishops, with a design to extend their own authority, and enlarge the sphere of their power and jurisdiction. The administration of the church itself was divided by Constantine into an *external* and *internal* inspection. The latter, which was committed to bishops and councils, related to religious controversies, the

forms of divine worship, the offices of priests, the vices of the ecclesiastical orders, &c. The external administration of the church the emperor assumed to himself. This comprehended all those things which related to the outward state and discipline of the church; it likewise extended to all contests that should arise between the ministers of the church, superior as well as inferior, concerning their possessions, their reputation, their rights and privileges, their offences against the laws, &c. but no controversies that related to matters purely spiritual were cognizable by this external inspection. In consequence of this artful division of the ecclesiastical government, Constantine and his successors called councils, presided in them, appointed the judges of religious controversies, terminated the differences which arose between the bishops and the people, fixed the limits of the ecclesiastical provinces, took cognizance of the civil causes that subsisted between the ministers of the church, and punished the crimes committed against the laws by the ordinary judges appointed for that purpose; giving over all causes purely ecclesiastical to the bishops and councils. But this famous division of the administration of the church was never explained with sufficient accuracy; so that both in the fourth and fifth centuries, there are frequent instances of the emperors determining matters purely ecclesiastical, and likewise of bishops and councils determining matters which related merely to the external form and government of the church.

After the time of Constantine many additions were made by the emperors and others to the wealth and honours of the clergy; and these additions were followed by a proportional increase of their vices and luxury, particularly among those who lived in great and opulent cities. The bishops, on the one hand, contended with each other in the most scandalous manner concerning the extent of their respective jurisdictions; while, on the other, they trampled on the rights of the people, violated the privileges of the inferior ministers, and imitated in their conduct and in their manner of living the arrogance, voluptuousness, and luxury of magistrates and princes. This pernicious example was soon followed by the several ecclesiastical orders. The presbyters, in many places, assumed an equality with the bishops in point of rank and authority. Many complaints are also made by the authors of this century about the vanity and effeminacy of the deacons. Those more particularly of the presbyters and deacons who filled the first stations of these orders, carried their pretensions to an extravagant length, and were offended at the notion of being placed on an equality with their colleagues. For this reason they not only assumed the titles of *arch-presbyters*, and *arch-deacons*, but also claimed a degree of authority and power much superior to that which was vested in the other members of their respective orders.

In the fifth century, the bishops of Constantinople having already reduced under their jurisdiction all the Asiatic provinces, began to grasp at still further accessions of power. By the 28th canon of the council held at Chalcedon in 451, it was resolved, that the same rights and honours which had been conferred on the bishop of Rome were due to the bishop of Constantinople, on account of the equal dignity and lustre of the two cities in which these prelates exercised their authority.

authority. The same council confirmed also, by a solemn act, the bishop of Constantinople in the spiritual government of those provinces over which he had usurped the jurisdiction. Leo the Great, bishop of Rome, opposed with vehemence the passing of these laws; and his opposition was seconded by that of several other prelates. But their efforts were vain, as the emperors threw in their weight into the balance, and thus supported the decisions of the Grecian bishops. In consequence, then, of the decisions of this famous council, the bishop of Constantinople began to contend obstinately for the supremacy with the Roman pontiff, and to crush the bishops of Antioch and Alexandria. About the same time, Juvenal, bishop of Jerusalem, attempted to withdraw himself and his church from the jurisdiction of the bishop of Cæsarea, and aspired after a place among the first prelates of the Christian world. The high degree of veneration and esteem in which the church of Jerusalem was held among all other Christian societies (on account of its rank among the apostolical churches, and its title to the appellation of *mother-church*, as having succeeded the first Christian assembly formed by the apostles), was extremely favourable to the ambition of Juvenal, and rendered his project much more practicable than it would otherwise have been. Encouraged by this, and likewise by the protection of Theodosius the younger, this aspiring prelate not only assumed the dignity of patriarch of all Palestine, a rank which rendered him independent of all spiritual authority; but also invaded the rights of the bishop of Antioch, and usurped his jurisdiction over the provinces of Phœnicia and Arabia. Hence arose a warm contest between Juvenal and Maximus bishop of Antioch; which the council of Chalcedon decided, by restoring to the latter the provinces of Phœnicia and Arabia, and confirming the former in the spiritual possession of all Palestine and in the high rank which he had assumed in the church.

In 588, John, bishop of Constantinople, surnamed the *Faster*, either by his own authority or that of the emperor Mauritius, summoned a council at Constantinople to acquire into an accusation brought against Gregory, bishop of Antioch; and upon this occasion assumed the title of *œcumenical* or *universal bishop*. This title had been formerly enjoyed by the bishops of Constantinople without any offence: but now, Gregory the Great, at that time bishop of Rome, suspecting that John was aiming at the supremacy over all the churches, opposed his claim with the greatest vigour. For this purpose he applied by letters to the emperor, and others, whom he thought capable of assisting him in his opposition; but all his efforts were without effect; and the bishops of Constantinople were allowed to enjoy the disputed title, though not in the sense which had alarmed the Roman pontiff.

Gregory, however adhered tenaciously to his purpose, raised new tumults and dissensions among the clergy, and aimed at nothing less than an unlimited supremacy over the Christian church. This ambitious design succeeded in the west; while in the eastern provinces, his arrogant pretensions were scarcely respected by any but those who were at enmity with the bishop of Constantinople. How much the people were at this time deluded by the Roman pontiffs, appears from the expression of Ennodius, one of the flatterers of Sym-

machus (who was a prelate of but ambiguous fame), that the Roman pontiff was constituted judge in the place of God, which he filled as the vicegerent of the Most High. On the other hand, it is certain, from a variety of the most authentic records, that both the emperors and the nations in general were far from being disposed to bear with patience the yoke of servitude which the see of Rome was arrogantly imposing on the whole church.

In the beginning of the seventh century, according to the most learned historians, Boniface III. engaged the Phocas, emperor of Constantinople, to take from the bishop of that metropolis the title of *œcumenical* or *universal bishop*, and to confer it upon the Roman pontiff; and thus was first introduced the supremacy of the pope. The Roman pontiffs used all methods to maintain and enlarge this authority and pre-eminence, which they had acquired from one of the most odious tyrants that ever disgraced the annals of history.

In the eighth century, the power of the bishop of Rome, and of the clergy in general, increased prodigiously. The chief cause of this, besides the superstition of the people, was the method at that time used by the European princes to secure themselves on their thrones. All these princes being then employed either in usurpation or in self-defence, and the whole continent being in the most unsettled and barbarous condition, they endeavoured to attach warmly to their interests these whom they considered as their friends and clients. For this purpose they distributed among them extensive territories, cities, and fortresses, with the various rights and privileges belonging to them; reserving only to themselves the supreme dominion, and the military service of these powerful vassals. For this reason it was by the European princes reckoned a high instance of political prudence to distribute among the bishops and other Christian doctors the same sort of donations which had formerly been given to their generals and clients. By means of the clergy, they hoped to check the seditious and turbulent spirits of their vassals; and to maintain them in their obedience by the influence and authority of their bishops, whose commands were highly respected, and whose spiritual thunderbolts, rendered formidable by ignorance, struck terror into the boldest and most resolute hearts.

This prodigious accession to the opulence and authority of the clergy in the west, began at their head, viz. the Roman pontiff; from whence it spread gradually among the inferior sacerdotal orders. The barbarous nations who had received the gospel, looked upon the bishop of Rome as the successor of their chief druid or high priest: and as this tremendous druid had enjoyed, under the darkness of Paganism, a kind of boundless authority; so these barbarous nations thought proper to confer upon the chief bishop the same authority which had belonged to the chief druid. The pope received these august privileges with great pleasure; and lest, upon any change of affairs, attempts should be made to deprive him of them, he strengthened his title to these extraordinary honours by a variety of passages drawn from ancient history, and, what is still more astonishing, by arguments of a religious nature. This swelled the Roman druid to an enormous size; and gave to the see of Rome that high pre-eminence and despotic authority in civil and political

Ecclesiastical History.

political matters, that were unknown to former ages. Hence, among other unhappy circumstances, arose that monstrous and pernicious opinion, that such persons as were excluded from the communion of the church by the pontiff himself, or any of the bishops, thus forfeited, not only their civil rights and advantages as citizens, but even the common claims and privileges of humanity. This horrid opinion, which was a fatal source of wars, massacres, and rebellions without number, and which contributed more than any thing else to confirm and augment the papal authority, was borrowed by the clergy from the Pagan superstitions.—Though excommunication, from the time of Constantine the Great, was in every part of the Christian world attended with many disagreeable effects; yet its highest terrors were confined to Europe, where its aspect was truly formidable and hideous. It acquired also, in the eighth century, new accessions of terror; so that from that period the excommunication practised in Europe differed entirely from that which was in use in other parts of Christendom. Excommunicated persons were indeed considered in all places as objects of hatred both to God and man; but they were not, on that account, robbed of the privileges of citizens, nor of the rights of humanity; much less were those kings and princes, whom an insolent bishop had thought proper to exclude from the communion of the church, supposed to forfeit on that account their crowns or their territories. But from this century it was quite otherwise in Europe. Excommunication received that infernal power which dissolved all connexions; so that those whom the bishops, or their chief, excluded from church communion, were degraded to a level with the beasts. The origin of this unnatural and horrid power was as follows:—On the conversion of the barbarous nations to Christianity, these ignorant proselytes confounded the excommunication in use among Christians with that which had been practised in the times of Paganism, and which was attended with all the dreadful effects above mentioned. The Roman pontiffs, on the other hand, were too artful not to encourage this error; and therefore employed all sorts of means to gain credit to an opinion so well calculated to gratify their ambition, and to aggrandize in general the episcopal order.

73
He becomes a temporal prince.

The annals of the French nation furnish us with the following instance of the enormous power which was at this time vested in the Roman pontiff. Pepin, who was mayer of the palace to Childeric III. king of France, and who in the exercise of that high office was possessed in reality of the royal power and authority, aspired to the titles and honours of majesty also, and formed a scheme of dethroning his sovereign. For this purpose he assembled the states in 751; and though they were devoted to the interests of this ambitious usurper, they gave it as their opinion that the bishop of Rome was previously to be consulted whether the execution of such a scheme was lawful or not. In consequence of this, ambassadors were sent by Pepin to Zachary, the reigning pontiff, with the following question, "Whether the divine law did not permit a valiant and warlike people to dethrone a pusillanimous and indolent prince who was incapable of discharging any of the functions of royalty; and to

substitute in his place one more worthy to rule, and who had already rendered most important services to the state?" The situation of Zachary, who stood much in need of the succour of Pepin against the Greeks and Lombards, rendered his answer such as the usurper desired: and when this favourable decision of the Roman oracle was published in France, the unhappy Childeric was stripped of his royalty without the least opposition; and Pepin, without the smallest resistance, stepped into the throne of his master and his sovereign. This decision was solemnly confirmed by Stephen II. the successor of Zachary; who undertook a journey into France in the year 754, in order to solicit assistance against the Lombards. The pontiff at the same time dissolved the obligation of the oath of fidelity and allegiance which Pepin had sworn to Childeric, and violated by his usurpation in the year 751; and to render his title to the crown as sacred as possible, Stephen anointed and crowned him, with his wife and two sons, for the second time. This complaisance of the pope was rewarded with the exarchate of Ravenna and all its dependencies, as we have already related. See *Civil History*, N^o 44. *supra*; and *History of ITALY*.

In the succeeding centuries, the Roman pontiffs continued to increase their power by every kind of artifice and fraud which can dishonour the heart of man; and by continually taking advantage of the civil dissensions which prevailed throughout Italy, France, and Germany, their influence in civil affairs rose to an enormous height. The increase of their authority in religious matters was not less rapid. The wisest and most impartial among the Roman Catholic writers acknowledge, that from the time of Louis the Meek the ancient rules of ecclesiastical government were gradually changed in Europe by the counsels and instigation of the church of Rome, and new laws substituted in their place. The European princes suffered themselves to be divested of the supreme authority in religious matters, which they had derived from Charlemagne; the power of the bishops was greatly diminished, and even the authority of both provincial and general councils began to decline. The popes, elated with their overgrown prosperity, and become arrogant beyond measure by the daily accessions that were made to their authority, were eagerly bent upon establishing the maxim, That the bishop of Rome was constituted and appointed by Jesus Christ supreme legislator and judge of the church universal; and that therefore the bishops derived all their authority from him. This opinion, which they inculcated with the utmost zeal and ardour, was opposed in vain by such as were acquainted with the ancient ecclesiastical constitutions, and the government of the church in the earlier ages. In order to gain credit to this new ecclesiastical code, and to support the pretensions of the popes to supremacy, it was necessary to produce the authority of ancient deeds, in order to stop the mouths of such as were disposed to set bounds to their usurpations. The bishops of Rome were aware of this; and as those means were looked upon as the most lawful that tended best to the accomplishment of their purposes, they employed some of their most ingenious and zealous partisans in forging conventions, acts of councils, epistles, and such like records, by which it might appear, that in the first ages of the church the

74
His power still increased.

Roman.

Ecclesiastical History.

Roman pontiffs were clothed with the same spiritual majesty and supreme authority which they now assumed. There were not, however, wanting among the bishops some men of prudence and sagacity, who saw through these impious frauds, and perceived the chains that were forging both for them and the church. The French bishops distinguished themselves eminently in this respect: but their opposition was soon quashed; and as all Europe was sunk in the grossest ignorance and darkness, none remained who were capable of detecting these odious impostures, or disposed to support the expiring liberty of the church.

75 Extreme violence of the pope.

This may serve as a general specimen of the character and conduct of the pretended vicegerents of Jesus Christ to the 16th century. In the 11th century, indeed, their power seems to have risen to its utmost height. They now received the pompous titles of *Masters of the World*, and *Popes*, i. e. *universal fathers*. They presided everywhere in the councils by their legates, assumed the authority of supreme arbiters in all controversies that arose concerning religion or church-discipline, and maintained the pretended rights of the church against the encroachments and usurpations of kings and princes. Their authority, however, was confined within certain limits: for, on the one hand, it was restrained by sovereign princes, that it might not arrogantly aim at civil dominion; and on the other, it was opposed by the bishops themselves, that it might not arise to a spiritual despotism, and utterly destroy the privileges and liberty of synods and councils. From the time of Leo IX. the popes employed every method which the most artful ambition could suggest to remove those limits, and to render their dominion both despotic and universal. They not only aspired to the character of supreme legislators in the church, to an unlimited jurisdiction over all synods and councils whether general or provincial, to the sole distribution of all ecclesiastical honours and benefices, as divinely authorised and appointed for that purpose; but they carried their insolent pretensions so far, as to give themselves out for lords of the universe, arbiters of the fate of kingdoms and empires, and supreme rulers over the kings and princes of the earth. Hence we find instances of their giving away kingdoms, and loosing subjects from their allegiance to their sovereigns; among which the history of John, king of England, is very remarkable. At last they plainly assumed the whole earth as their property, as well where Christianity was preached as where it was not; and therefore, on the discovery of America and the East Indies, the pope, by virtue of this spiritual property, granted to the Portuguese a right to all the countries lying eastward, and to the Spaniards all those lying to the westward, of Cape Non in Africa, which they were able to conquer by force of arms; and that nothing might be wanting to complete their character, they pretended to be lords of the future world also, and to have a power of restraining even the divine justice itself, and remitting that punishment which the Deity hath denounced against the workers of iniquity.

76 Christianly greatly corrupted. Avocations of saints, relics, purgatory, &c. introduced.

All this time the powers of superstition reigned triumphant over those remains of Christianity which had escaped the corruptions of the first four centuries. In the fifth century began the invocation of the happy souls of departed saints. Their assistance was in-

treated by many fervent prayers, while none stood up to oppose this preposterous kind of worship. The images of those who during their lives had acquired the reputation of uncommon sanctity, were now honoured with a particular worship in several places; and many imagined that this drew into the images the propitious presence of the saints or celestial beings which they were supposed to represent. A singular and irresistible efficacy was attributed to the bones of martyrs, and to the figure of the cross, in defeating all the attempts of Satan, removing all sorts of calamities, and in healing not only the diseases of the body, but also those of the mind. The famous Pagan doctrine concerning the *purgation of departed souls* by means of a certain kind of fire, i. e. purgatory, was also confirmed and explained more fully than it had formerly been; and every one knows of how much consequence this absurd doctrine hath been to the wealth and power of the Romish clergy.

Ecclesiastical History.

In the sixth century, Gregory the Great advanced an opinion, That all the *words* of the sacred writings were *images* of invisible and spiritual things; for which reason he loaded the churches with a multitude of ceremonies the most insignificant and futile that can be imagined; and hence arose a new and most difficult science, namely, the explication of these ceremonies, and the investigation of the causes and circumstances whence they derived their origin. A new method was contrived of administering the Lord's Supper, with a magnificent assemblage of pompous ceremonies. This was called the *canon of the mass*. Baptism, except in cases of necessity, was administered only on the great festivals. An incredible number of temples was erected in honour of the saints. The places set apart for public worship were also very numerous: but now they were considered as the means of purchasing the protection and favour of the saints; and the ignorant and barbarous multitude were persuaded, that these departed spirits defended and guarded against evils and calamities of every kind, the provinces, lands, cities, and villages in which they were honoured with temples. The number of these temples was almost equalled by that of the festivals, which seem to have been invented in order to bring the Christian religion as near the model of Paganism as possible.

77 Introduction of the mass.

In the seventh century, religion seemed to be altogether buried under a heap of superstitious ceremonies; the worship of the true God and Saviour of the world was exchanged for the worship of bones, bits of wood (said to be of the cross), and the images of saints. The eternal state of misery threatened in Scripture to the wicked was exchanged for the temporary punishment of purgatory; and the expressions of faith in Christ by an upright and virtuous conduct, for the augmentation of the riches of the clergy by donations to the church, and the observance of a heap of idle ceremonies. New festivals were still added; one in particular was instituted in honour of the *true cross* on which our Saviour suffered; and churches were declared to be sanctuaries to all such as fled to them, whatever their crimes might have been.

78 Superstition still increases.

Superstition, it would seem, had now attained its highest pitch; nor is it easy to conceive a degree of ignorance and degeneracy beyond what we have already mentioned. If any thing can possibly be imagined more

more contrary to true religion, it is an opinion which prevailed in the eighth century, namely, That Christians might appease an offended Deity by voluntary acts of mortification, or by gifts and oblations lavished on the church; and that people ought to place their confidence in the works and merits of the saints. The piety in this and some succeeding ages consisted in building and embellishing churches and chapels; in endowing monasteries and basilics; hunting after the relics of saints and martyrs, and treating them with an absurd and excessive veneration; in procuring the intercession of the saints by rich oblations, or superstitious rites; in worshipping images; in pilgrimages to those places which were esteemed holy, particularly to Palestine, &c. The genuine religion of Jesus was now utterly unknown both to clergy and people, if we except a few of its general doctrines contained in the creed. In this century also, the superstitious custom of *solitary masses* had its origin. These were celebrated by the priest alone in behalf of souls detained in purgatory, as well as upon some other occasions. They were prohibited by the laws of the church, but proved a source of immense wealth to the clergy. Under Charlemagne they were condemned by a synod assembled at Mentz, as criminal effects of avarice and sloth. A new superstition, however, still sprung up in the tenth century. It was imagined, from Rev. xx. 1. that Antichrist was to make his appearance on the earth, and that soon after the world itself would be destroyed. An universal panic ensued; vast numbers of people, abandoning all their connections in society, and giving over to the churches and monasteries all their worldly effects, repaired to Palestine, where they imagined that Christ would descend from heaven to judge the world. Others devoted themselves by a solemn and voluntary oath to the service of the churches, convents, and priesthood, whose slaves they became, in the most rigorous sense of that word, performing daily their heavy tasks; and all this from a notion that the supreme Judge would diminish the severity of their sentence, and look upon them with a more favourable and propitious eye, on account of their having made themselves the slaves of his ministers. When an eclipse of the sun or moon happened to be visible, the cities were deserted, and their miserable inhabitants fled for refuge to hollow caverns, and hid themselves among the craggy rocks, and under the bending summits of steep mountains. The opulent attempted to bribe the saints and the Deity himself by rich donations conferred upon the sacerdotal tribe, who were looked upon as the immediate vicegerents of heaven. In many places, temples, palaces, and noble edifices both public and private, were suffered to decay, nay, were deliberately pulled down, from a notion that they were no longer of any use, as the final dissolution of all things was at hand. In a word, no language is sufficient to express the confusion and despair that tormented the minds of miserable mortals upon this occasion. The general delusion was indeed opposed and combated by the discerning few, who endeavoured to dispel these terrors, and to efface the notion from which they arose in the minds of the people. But their attempts were ineffectual; nor could the dreadful apprehensions of the superstitious multitude be removed before the end of

the century, and this terror became one of the accidental causes of the **CROISADES**.

That nothing might now be wanting to complete that antichristian system of religion which had overspread all Europe, it was in the 11th century determined that divine worship should be celebrated in the Latin tongue, though now unknown throughout the whole continent. During the whole of this century, also, Christians were employed in the rebuilding and ornamenting their churches, which they had destroyed through the superstitious fears already taken notice of.

In much the same way with what is above related, or worse if possible, matters went on till the time of the reformation. The clergy were immersed in crimes of the deepest dye; and the laity, imagining themselves able to purchase pardon of their sins for money, followed the examples of their pastors without remorse. The absurd principle formerly mentioned, namely, that religion consists in acts of austerity, and an unknown mental correspondences with God, produced the most extravagant and ridiculous behaviour in the devotees and reputed saints. They not only lived among the wild beasts, but also after the manner of these savage animals: they ran naked through the lonely deserts with a furious aspect, and all the agitations of madness and frenzy; they prolonged their wretched life by grass and wild herbs, avoided the sight and conversation of men, remained almost motionless in certain places for several years, exposed to the rigour and inclemency of the seasons, and towards the conclusion of their lives shut themselves up in narrow and miserable huts; and all this was considered as true piety, the only acceptable method of worshipping the Deity and attaining a share in his favour.—But of all the instances of superstitious frenzy which disgraced the times we now speak of, none was held in higher veneration, or excited more the wonder of the multitude, than that of a certain order of men who were called *Stylites* by the Greeks, and *Sancti Columnares*, or Pillar Saints, by the Latins. These were persons of a most singular and extravagant turn of mind, who stood motionless on the tops of *pillars* expressly raised for this exercise of their patience, and remained there for several years amidst the admiration and applause of the stupid populace. The inventor of this strange discipline was one *Simeon* a Syrian, who began his follies by changing the agreeable employment of a shepherd for the austerities of a monkish life. He began his devotion on the top of a pillar six cubits high; but as he increased in sanctity, he also increased the height of his pillar, till, towards the conclusion of his life, he had got up on the top of a pillar 40 cubits in height. Many of the inhabitants of Syria and Palestine, seduced by a false ambition and an utter ignorance of true religion, followed the example of this fanatic, though not with the same degree of austerity. This superstitious practice began in the fifth century, and continued in the east for 600 years. The Latins, however, had too much wisdom and prudence to imitate the Syrians and Orientals in this whimsical superstition; and when a certain fanatic, or impostor, named *Wulfilaicus*, erected one of these pillars in the country of Treves, and proposed to live on it after the manner

Constitutional
History.

of Simeon, the neighbouring bishops ordered it to be pulled down.

The practices of austere worship and discipline in other respects, however, gained ground throughout all parts of Christendom. Monks of various kinds were to be found in every country in prodigious numbers. But though their discipline was at first exceedingly severe, it became gradually relaxed, and the monks gave into all the prevailing vices of the times. Other orders succeeded, who pretended to still greater degrees of sanctity, and to reform the abuses of the preceding ones; but these in their turn became corrupted, and fell into the same vices they had blamed in others. The most violent animosities, disputes, and hatred, also reigned among the different orders of monks; and, indeed, between the clergy of all ranks and degrees, whether we consider them as classed in different bodies, or as individuals of the same body. To enter into a detail of their wranglings and disputes, the methods which each of them took to aggrandise themselves at the expence of their neighbours, and to keep the rest of mankind in subjection, would require many volumes. We shall only observe, therefore, that even the external profession of the austere and absurd piety which took place in the fourth and fifth centuries, continued gradually to decline. Some there were, indeed, who boldly opposed the torrent of superstition and wickedness which threatened to overflow the whole world: but their opposition proved fruitless, and all of these towards the era of the reformation had been either silenced or destroyed: so that, at that time, the pope and clergy reigned over mankind without controul, had made themselves masters of almost all the wealth in every country of Europe, and may truly be said to have been the only *sovereigns*; the rest of the human race, even kings and princes, being only their vassals and slaves.

So
is of
Mahometanism.

While the Popish superstition reigned thus violently in the west, the absurd doctrines of Mahomet overspread all the east. The rise of this impostor is related under the article ARABIA. His successors conquered in order to establish the religion of their apostle; and thus the very name of Christianity was extinguished in many places where it had formerly flourished. The conquests of the Tartars having intermingled them with the Mahometans, they greedily embraced the superstitions of that religion, which thus almost entirely overspread the whole continents of Asia and Africa; and, by the conquest of Constantinople by the Turks in 1453, was likewise established throughout a considerable part of Europe.

So
is of
Romanism in
the beginning
of the
16th century
and
so that
is.

About the beginning of the 16th century, the Roman pontiffs lived in the utmost tranquillity; nor had they, according to the appearance of things at that time, any reason to fear an opposition to their authority in any respect, since the commotions which had been raised by the Waldenses, Albigenses, &c. were now entirely suppressed. We must, not, however, conclude, from this apparent tranquillity and security of the pontiffs and their adherents, that their measures were universally applauded. Not only private persons, but also the most powerful princes and sovereign states, exclaimed loudly against the tyranny of the popes, and the unbridled licentiousness of the clergy of all

denominations. They demanded, therefore, a reformation of the church in its head and members, and a general council to accomplish that necessary purpose. But these complaints and demands were not carried to such a length as to produce any good effect; since they came from persons who never entertained the least doubt about the supreme authority of the pope in religious matters, and who, of consequence, instead of attempting themselves to bring about that reformation which was so ardently desired, remained entirely inactive, or looked for redress to the court of Rome, or to a general council. But while the so much desired reformation seemed to be at such a great distance, it suddenly arose from a quarter whence it was not at all expected. A single person, Martin Luther, a monk of the order of St Augustine, ventured to oppose himself to the whole torrent of papal power and despotism. This bold attempt was first made public on the 30th of Sept. 1517; and notwithstanding all the efforts of the pope and his adherents, the doctrines of Luther continued daily to gain ground. Others, encouraged by his success, lent their assistance in the work of reformation; which at last produced new churches, founded upon principles quite different from that of Rome, and which still continue. But for a particular account of the transactions of the first reformers, the opposition they met with, and the final settlement of the reformed churches in different nations in Europe, see the articles LUTHER and REFORMATION.

The state of religion in other parts of the world seems as yet to be but little altered. Asia and Africa are sunk in the grossest superstitions either of the Mahometan or Pagan kinds. The southern continent of America, belonging to the Spaniards, continues immersed in the most absurd superstitions of Popery. The northern continent, being mostly peopled with colonies from Great Britain, professes the reformed religion. At the same time it must be owned, that some kind of reformation hath taken place even in Popery and Mahometanism themselves. The popes have no longer that authority over states and princes, even those most bigotted to Popery, which they formerly had. Neither are the lives either of the clergy or laity so corrupt as they were before. The increase of learning in all parts of the world has contributed to cause men open their eyes to the light of reason, and this hath been attended with a proportional decrease of superstition. Even in Mahometan countries, that furious enthusiasm which formerly emboldened their inhabitants to face the greatest dangers, hath now almost vanished; so that the credit of Mahomet himself seems to have sunk much in the estimation of his followers. This is to be understood even of the most ignorant and bigotted multitude; and the sensible part of the Turks are said to incline much towards deism. With regard to those nations which still profess Paganism, the intercourse of Europeans with them is so small, that it is impossible to say any thing concerning them. As none of them are in a state of civilization, however, it may be conjectured, that their religion is of the same unpolished cast with their manners; and that it consists of a heap of barbarous superstitions which have been handed down among them from time immemorial, and which they continue to observe without knowing why or wherefore.

Ecclesiastical
History.

Composi-
tion of
History.

SECT. III. Of the Composition of History.

Composi-
tion of
History.

82
Cicero's
rules.

CICERO has given us the whole art of composing history, in a very short and comprehensive manner. We shall first transcribe what he says, and then consider the several parts of it in their proper order. "No one is ignorant (says he), that the first law in writing history is, Not to dare to say any thing that is false; and the next, Not to be afraid to speak the truth: that on the one hand there be no suspicion of affection, nor of prejudice on the other. These foundations are what all are acquainted with. But the superstructure consists partly in things, and partly in the style or language. The former require an order of times, and descriptions of places. And because, in great and memorable events, we are desirous to know first their causes, then the actions themselves, and lastly their consequences; the historian should take notice of the springs or motives that occasioned them; and, in mentioning the facts themselves, should not only relate what was done or said, but likewise in what manner; and, in treating upon their consequences, show if they were the effects of chance, wisdom, or imprudence. Nor should he only recite the actions of great and eminent persons, but likewise describe their characters. The style ought to be fluent, smooth, and even, free from that harshness and poignancy which is usual at the bar." Thus far Cicero. A history written in this manner, and furnished with all these properties, must needs be very entertaining, as well as instructive. And perhaps few have come nearer this plan than Tacitus; though his subject is attended with this unhappy circumstance, or at least unpleasant one, that it affords us examples rather of what we ought to avoid than what to imitate. But it is the business of the historian, as well as of the philosopher, to represent both virtues and vices in their proper colours; the latter doing it by precepts, and the former by examples. Their manner is different; but the end and design of both is, or should be, the same: And therefore history has not improperly been said by some to be moral philosophy exemplified in the lives and actions of mankind.

De Orat.
lib. II. c. 15.

We shall reduce these several things mentioned by Cicero to three heads, Matter, Order, and Style; and treat upon each of them separately. But as Truth is the basis and foundation of all history, it will be necessary to consider that in the first place.

ART. I. OF TRUTH in History.

83
Of historic
truth.

Truth is, as it were, the very life and soul of history, by which it is distinguished from fable or romance. A historian therefore ought not only to be a man of probity, but void of all passion or bias. He must have the steadiness of a philosopher, joined with the vivacity of a poet or orator. Without the former, he will be insensibly swayed by some passion to give a false colouring to the actions or characters he describes, as favour or dislike to parties or persons affect his mind. Whereas he ought to be of no party, nor to have either friend or foe while writing; but to preserve himself in a state of the greatest indifferency to all, that he may judge of things as they really are in

their own nature, and not as connected with this or that person or party. And with this firm and sedate temper, a lively imagination is requisite; without which his descriptions will be flat and cold, nor will he be able to convey to his readers a just and adequate idea of great and generous actions. Nor is the assistance of a good judgment less necessary than any of the former qualities, to direct him what is proper to be said and what to be omitted, and to treat every thing in a manner suitable to its importance. And since these are the qualifications necessary for a historian, it may perhaps seem the less strange that we have so few good histories.

But historical truth consists of two parts; one is, Not to say any thing we know to be false: Though it is not sufficient to excuse a historian in relating a falsehood that he did not know it was so when he wrote it, unless he first used all the means in his power to inform himself of the truth; for then, undoubtedly, an invincible error is as unpardonable in history as in morality. But the generality of writers in his kind content themselves with taking their accounts from hearsays, or transcribing them from others, without duly weighing the evidence on which they are founded, or giving themselves the trouble of a strict inquiry. Few will use the diligence necessary to inform themselves of the certainty of what they undertake to relate. And as the want of this greatly abates the pleasure of reading such writers, while persons read with diffidence; so nothing more recommends an historian than such industry. Thus we are informed of Thucydides, that when he wrote his history of the Peloponnesian war, he did not satisfy himself with the best accounts he could get from his countrymen the Athenians, fearing they might be partial in their own cause; but spared no expence to inform himself how the same facts were related by their enemies the Lacedæmonians; that, by comparing the relations of both parties, he might better judge of the truth. And Polybius took greater pains than he, in order to write his history of the Roman affairs; for he travelled into Africa, Spain, and Gaul, and other parts of the world, that by viewing the several scenes of action, and informing himself from the inhabitants, he might come at a greater certainty of the facts, and represent them in a juster light. But as an historian ought not to assert what he knows to be false; so he should likewise be cautious in relating things which are doubtful, and acquaint his readers with the evidence he goes upon in such facts, from whence they may be able to judge how far it is proper to credit them. So Herodotus tells us what things he saw himself in his travels, and what he heard from the information of the Egyptian priests and others with whom he conversed. And Curtius, in the life of Alexander, speaking of the affairs of India, ingenuously confesses, that he wrote more than he fully believed. "For (says he) I neither dare to affirm positively what I doubt of, nor can I think it proper to omit what I have been told." By such a conduct the author secures his credit, whether the things prove really true or false; and gives room for further inquiry, without imposing on his readers.

The other branch of historical truth is, Not to omit any thing that is true, and necessary to set the matter treated of in a clear and full light. In the actions of

past

Composition of History. past ages or distant countries, wherein the writer has no personal concern. He can have no great inducement to break in upon this rule. But where interest or party is engaged, it requires no small candour, as well as firmness of mind, constantly to adhere to it. Affection to some, aversion to others, fear of obliging friends or those in power, will often interpose and try his integrity. Besides, an omission is less obvious to censure than a false assertion: for the one may be easily ascribed to ignorance or forgetfulness; whereas the other will, if discovered, be commonly looked upon as design. He therefore who, in such circumstances, from a generous love to truth, is superior to all motives to betray or stifle it, justly deserves the character of a brave as well as honest man. What Polybius says upon this head is very well worth remarking: "A good man ought to love his friends and his country, and to have a like disposition with them, both towards their friends and enemies. But when he takes upon him the character of a historian, they must all be forgot. He must often speak well of his enemies, and commend them when their actions deserve it; and sometimes blame, and even upbraid his greatest friends, when their conduct makes it necessary. Nor must he forbear sometimes to reprove, and at other times to commend the same persons; since all are liable to mistake in their management, and there are scarce any persons who are always in the wrong. Therefore, in history, all personal considerations should be laid aside, and regard had only to their actions."

What a different view of mankind and their actions should we have were these rules observed by all historians? Integrity is undoubtedly the principal qualification of a historian; when we can depend upon this, other imperfections are more easily passed over. Suetonius is said to have written the lives of the first twelve Roman emperors with the same freedom wherewith they themselves lived. What better character can be given of a writer? The same ingenuous temper appears in the two Grecian historians above mentioned, Thucydides and Polybius: The former of whom, though banished by his countrymen the Athenians, yet expresses no marks of resentment in his history, either against them in general, or even against the chief authors of it, when he has occasion to mention them; and the latter does not forbear censuring what he thought blameable in his nearest relations and friends. But it is often no easy matter to know whether a historian speaks truth or not, and keeps up to the several characters here mentioned; though it seems reasonable, upon the common principles of justice due to all mankind, to credit him where no marks of partiality or prejudice appear in his writings. Sometimes, indeed, a judgment may in a good measure be formed of the veracity of an author from his manner of expressing himself. A certain candour and frankness, that is always uniform and consistent with itself, runs through their writings who have nothing in view but truth, which may be justly esteemed as a very good evidence of their sincerity. Whereas those who have partial designs to answer are commonly more close and covert; and if at other times they assume an air of openness and freedom, yet this is not constant and even, but soon followed again with the

appearance of some bias and reserve: for it is very difficult to act a part long together without lying open to a discovery. And therefore, though craft and design is exceeding various, and, Proteus-like, assumes very different shapes, there are certain characters by which it may often be perceived and detected. Thus, where things are uncertain by reason of their being reported various ways, it is partiality in a historian to give into the most unfavourable account, where others are as well known and equally credible. Again, it is a proof of the same bad temper, when the facts themselves are certain and evident, but the design and motives of those concerned in them are unknown and obscure, to assign some ill principle, such as avarice, ambition, malice, interest, or any other vicious habit, as the cause of them. This conduct is not only unjust to the persons whose actions they relate; but hurtful to mankind in general, by endeavouring to destroy the principal motive to virtue, which springs from example. Others, who affect to be more covert, content themselves with suspicions and sly insinuations; and then endeavour to come off, by intimating their unwillingness to believe them, though they would have their readers do so. And to mention no more, there are others, who, when they have loaded persons with unjust calumnies and reflections, will allow them some slight commendations, to make what they have said before look more credible, and themselves less partial. But the honest and faithful historian contemns all such low and mean arts; he considers things as they are in themselves, and relates them as he finds them without prejudice or affection.

ART. II. THE SUBJECT OR ARGUMENT OF HISTORY.

The *subject* in general is facts, together with such things as are either connected with them, or may at least be requisite to set them in a just and proper light. But although the principal design of history be to acquaint us with facts, yet all facts do not merit the regard of an historian; but such only as may be thought of use and service for the conduct of human life. Nor is it allowable for him, like the poet, to form the plan and scheme of his work as he pleases. His business is to report things as he finds them, without any colouring or disguise to make them more pleasing and palatable to his reader, which would be to convert his history into a novel. Indeed some histories afford more pleasure and entertainment than others, from the nature of the things of which they consist; and it may be esteemed the happiness of an historian to meet with such a subject, but it is not his fault if it be otherwise. Thus Herodotus begins his history with showing, that the barbarians gave the first occasion to the wars between them and the Greeks, and ends it with an account of the punishment which, after some ages, they suffered from the Greeks on that account. Such a relation must not only be very agreeable to his countrymen the Grecians, for whose sakes it was written; but likewise very instructive, by informing them of the justice of Providence in punishing public injuries in this world, wherein societies, as such, are only capable of punishment. And therefore those examples might be of use to caution them against the like practices. On the contrary, Thucydides begins his history with the unhappy state of his countrymen the Athenians; and in

Composition of History.

84
Subject of history.

Composition of History.

the course of it plainly intimates, that they were the cause of the calamitous war-between them and the Lacedæmonians. Whereas, had he been more inclined to please and gratify his countrymen than to write the truth, he might have set things in such a light as to have made their enemies appear the aggressors. But he scorned to court applause at the expence of truth and justice, and has set a noble example of integrity to all future historians. But as all actions do not merit a place in history, it requires no small judgement in an historian to select such only as are proper. Cicero observes very justly, that history "is conversant in great and memorable actions." For this reason, an historian should always keep posterity in view; and relate nothing which may not, upon some account or other, be worth the notice of after-ages. To descend to trivial and minute matters, such as frequently occur in the common affairs of life, is below the dignity of history. Such writers ought rather to be deemed journalists than historians, who have no view or expectation that their works should survive them. But the skilful historian is fired with a more noble ambition. His design is to acquaint succeeding ages with what remarkable occurrences happened in the world before them; to do justice to the memory of great and virtuous men; and at the same time to perpetuate his own. Pliny the younger has some fine reflections upon this head, in a letter to a friend. "You advise me (says he) to write a history; and not you only, for many others have done the same, and I am myself inclined to it. Not that I believe myself qualified for it, which would be rash to think till I have tried it; but because I esteem it a generous action not to suffer those to be forgotten whose memory ought to be eternalised; and to perpetuate the names of others, together with one's own. For there is nothing I am so desirous or ambitious of, as to be remembered hereafter; which is a thing worthy of a man, especially of one who, conscious of no guilt, has nothing to fear from posterity. Therefore I am thinking day and night by what means, as Virgil says,

— My name

To raise aloft;

That would suffice me; for it is above my wish to add with him,

— and wing my flight to fame.

But oh!

Lib. v. ep. 8.

However, this is enough, and what history alone seems to promise." This was Pliny's opinion with regard to the use and advantage of history; the subjects of which are generally matters of weight and importance. And therefore, when a prudent historian thinks it convenient to take notice of things in themselves less considerable, he either does it with brevity, or for some apparent reason, or accounts for it by some just apology. So Dion Cassius, when he has mentioned some things of less moment in the life of Commodus (as indeed that emperor's life was chiefly filled up with cruelty and folly), makes this excuse for himself: "I would not have it thought that I descend below the gravity of history in writing these things: For, as they were the actions of an emperor, and I was present and saw them all, and both heard and conversed

with him, I did not think it proper to omit them." He seems to think those actions, when performed by an emperor might be worth recording, which, if done by a person of inferior rank, would scarce have deserved notice. Nor does he appear to have judged amiss, if we consider what an influence the conduct and behaviour of princes, even in the common circumstances of life, have upon all beneath them; which may sometimes render them not unworthy the regard of an historian, as examples either for imitation or caution.

But although facts in general are the proper subject of history, yet they may be differently considered with regard to the extent of them, as they relate either to particular persons or communities of men. And from this consideration history has been distinguished into three sorts, viz. *biography*, *particular* and *general history*. The lives of single persons is called *biography*. By *particular history* is meant that of particular states, whether for a shorter or longer space of time. And *general history* contains an account of several states existing together in the same period of time.

1. The subjects of *biography* are the lives either of public or private persons; for many useful observations in the conduct of human life may be made from just accounts of those who have been eminent and beneficial to the world in either station. Nay, the lives of vicious persons are not without their use, as warnings to others, by observing the fatal consequences which sooner or later generally follow such practices. But for those who exposed their lives, or otherwise employed their time and labour, for the service of their fellow-creatures, it seems but a just debt that their memories should be perpetuated after them, and posterity acquainted with their benefactors. The expectation of this was no small incentive to virtue in the Pagan world. And perhaps every one, upon due reflection, will be convinced how natural this passion is to mankind in general. And it was for this reason, probably, that Virgil places not only his heroes, but also the inventors of useful arts and sciences, and other persons of distinguished merit, in the Elysian Fields, where he thus describes them:

Here patriots live, who, for their country's good,
In fighting fields were prodigal of blood;
Priests of unblemish'd lives here make abode,
And poets worthy their inspiring god;
And searching wits of more mechanic parts,
Who grac'd their age with new invented arts;
Those who to worth their bounty did extend,
And those who knew that bounty to commend:
The heads of these with holy fillets bound,
And all their temples were with garlands crown'd.

ÆNEID, vi. 66.

In the lives of public persons, their public characters are principally, but not solely, to be regarded. The world is inquisitive to know the conduct of princes and other great men, as well in private as public. And both, as has been said, may be of service, considering the influence of their examples. But to be over-inquisitive in searching into the weaknesses and infirmities of the greatest or best of men, is, to say no more of it, but a needless curiosity. In the writers of this kind, Plutarch is justly allowed to excel.

But it has been a matter of dispute among the learned,

Composition of History.

85
Different kinds of history.

Composition of History.

Composition of History.

learned, whether any one ought to write his own history. It may be pleaded in favour of this, that no one can be so much master of the subject as the person himself; and besides, there are many instances both ancient and modern, to justify such a conduct. But on the other hand it must be owned, that there are many inconveniencies which attend it; some of which are mentioned by Cicero. "If (says he) there is any thing commendable, persons are obliged to speak of themselves with greater modesty, and to omit what is blameable in others. Besides, what is said is not so soon credited, and has less authority; and after all, many will not stick to censure it." And Pliay says very well to the same purpose, "Those who proclaim their own virtues, are thought not so much to proclaim them because they did them, as to have done them that they might proclaim them. So that which would have appeared great if told by another, is lost when related by the party himself. For when men cannot deny the fact, they reflect upon the vanity of its author. Wherefore, if you do things not worth mentioning, the actions themselves are blamed; and if the things you do are commendable, you are blamed for mentioning them." These reflections will be generally allowed to be very just; and yet considering how natural it is for men to love themselves, and to be inclined in their own favour, it seems to be a very difficult task for any one to write an impartial history of his own actions. There is scarce any treatise of this kind that is more celebrated than Cæsar's Commentaries. And yet Suetonius tells us, that "Asinius Pollio (who lived at that time) thought they were neither written with due care nor integrity: that Cæsar was often too credulous in his accounts of what was done by other persons; and misrepresented his own actions, either designedly, or through forgetfulness; and therefore he would have revised and corrected them." However, at some times it may doubtless be justifiable for a person to be his own historian. Plutarch mentions two cases wherein it is allowable for a man to commend himself, and be the publisher of his own merits. These are, when the doing of it may be of considerable advantage either to himself or others. It is indeed less invidious for other persons to undertake the province. And especially for a person to talk or write of his own virtues, at a time when vice and a general corruption of manners prevails, let what he says be ever so true, it will be apt at least to be taken as a reflection upon others. "Anciently (says Tacitus), many wrote their own lives, rather as a testimony of their conduct, than from pride." Upon which he makes this judicious remark: "That the more virtue abounds, the sooner the reports of it are credited." But the ancient writers had a way of taking off the reader's attention from themselves in recording their own actions, and so rendering what they said less invidious; and that was, by speaking of themselves in the third person, and not in the first. Thus Cæsar never says, "I did," or "I said, this or that;" but always, "Cæsar did, or said, so and so." Why the moderns have not more chosen to follow them in this, we know not, since it seems less exceptionable.

2. In a continued history of particular states, some account may be given of their original, and founders; the nature of their soil, and situation; what advan-

tages they have for their support or improvement, either within themselves, by foreign traffic, or conquest; with the form of their government. Then notice should be taken of the methods by which they increased in wealth or power, till they gradually advanced to their highest pitch of grandeur; whether by their virtue, the goodness of their constitution, trade, industry, wars, or whatever cause. After this the reasons of their declension should be shown; what were the vices that principally occasioned it (for that is generally the case); whether avarice, ambition, luxury, discord, cruelty, or several of these in conjunction. And lastly, where that has been their unhappy fate, how they received their final ruin and subversion. Most of these things Livy had in view when he wrote his History of the Roman State, as he acquaints his readers in the preface. "The accounts (says he) of what happened either before or while the city was building, consisting rather of poetical fables than any certain records of facts, I shall neither assert nor confute them. Let antiquity be allowed to make the origin of their cities more venerable, by uniting things human and divine. But if any nation may be suffered to fetch their origin from the gods, such is the military glory of the Romans, that when they represent Mars as the father of their founder, other nations may as easily acquiesce in this as they do in their government. But I lay no great stress upon these things, and others of the like nature, whatever may be thought of them. What I am desirous every one should carefully attend to, are our lives and manners: by what men, and what arts, civil and military, the empire was both acquired and enlarged: then let him observe, how our manners gradually declined with our discipline; afterwards grew worse and worse; and at length so far degenerated, that at present we can neither bear with our vices nor suffer them to be remedied. This is the chief benefit and advantage to be reaped from history, to fetch instruction from eminent examples of both kinds; in order to imitate the one, which will be of use both to yourself and your country, and avoid the other, which are equally base in their rise and event." Thus far Livy. And how well he has executed this design must be acknowledged by all who will be at the pains to peruse his work.

3. But as a particular history consists in a number of facts relating to the same state, suitably connected and laid together in a proper series; so a general history is made up of several particular histories, whose separate transactions within the same period of time, or part of it, should be so distinctly related as to cause no confusion. Such was the history of Diodorus Siculus, which contained an account of most of the eminent states and kingdoms in the world, though far the greatest part of it is now unhappily lost. Of the same nature is the history of Herodotus, though not so extensive; to whom we are especially indebted for the Persian affairs. And to this kind may likewise be referred Justin's history, though it be only the epitome of a larger work written by another hand. The rules proper for conducting such histories are much the same as those above mentioned concerning particular histories; excepting what relates to the order, of which we shall have occasion to speak hereafter.

But the histories both of particular states and those

d Fam. l. v. l. II.

ab. viii. l. I.

Composi-
tion of
History.

which are more general frequently contain only the affairs of some short period of time. Thus the history of the Peloponnesian war, written by Thucydides, comprises only what was done in the first 20 years of that war, which lasted seven years longer than his account reaches; though indeed the reason of that might be, because Thucydides died before the war was finished, otherwise he would very probably have continued his history to the conclusion of it. But the history of the war between the Romans and King Jugurtha in Africa, given us by Sallust, as also Cæsar's histories of the Gallic and Civil wars, are all confined within a much less number of years than that of Thucydides. Nay, sometimes one single transaction is thought sufficient to furnish out a history. Such was the conspiracy of Catiline to subvert the Roman state, written likewise by Sallust. As to more general histories, Xenophon's history of Greece may be esteemed as such; which in order of time succeeds that of Thucydides, and contains the affairs of 48 years. And Polybius called his a *general history*; which, though it principally contained the Roman affairs, yet took in the most remarkable transactions of several other states, for the space of 53 years: though it has met with the same hard fate as that of Diodorus Siculus, so that only the first five books out of forty, of which it consisted at first, now remain entire. And to mention no more, the celebrated history of Thuanus is another instance of this sort, in which the principal transactions of Europe for about 60 years, chiefly in the 16th century, are described with that judgment and fidelity, and in a manner so accurate and beautiful, that he has been thought scarcely inferior to any of the ancient historians. Now, in such histories as these, to go farther back than is necessary to set the subject in a just light, seems as improper as it is unnecessary.

The general subject or argument of history, in its several branches, may be reduced to these four heads; *narration, reflections, speeches, and digressions.*

86
Of narra-
tion.

I: By *narration* is meant a description of facts or notions, with such things as are necessarily connected with them; namely, persons, time, place, design, and event.

As to *actions* themselves, it is the business of the historian to acquaint his readers with the manner in which they were performed; what measures were concerted on all sides, and how they were conducted, whether with vigilance, courage, prudence, and caution, or the contrary, according to the nature of the action; as likewise, if any unforeseen accidents fell out, by which the designed measures were either promoted or broken. All actions may be referred to two sorts, military and civil. And as war arises from injustice and injuries received on one side or the other, it is fit the reader should be informed who were the aggressors. For though war is never to be desired, yet it is sometimes necessary. In the description of battles, regard should be had equally to both parties; the number of forces, conduct of the generals, in what manner they engaged, what turns and chances happened in the engagement, either from accidents, courage, or stratagem, and how it issued. The like circumstances should all be observed in sieges and other

actions. But the most agreeable scene of history arises from a state of peace. Here the writer acquaints us with the constitution of states, the nature of their laws, the manners and customs of the inhabitants, the advantages of concord and unanimity, with the disadvantages of contention and discord; the invention of arts and sciences, in what manner they were improved and cultivated, and by whom; with many other things, both pleasant and profitable in the conduct of life.

As to *persons*, the characters of all those should be described who act any considerable part in a history. This excites the curiosity of the reader, and makes him more attentive to what is said of them; as one is more inquisitive to hear what relates to others in proportion to his knowledge of them. And it will likewise be of use to observe, how their actions agree with their characters, and what were the effects of their different qualifications and abilities.

The circumstances of *time* and *place* are carefully to be regarded by an historian, without which his accounts of facts will be frequently very lame and imperfect. And therefore *chronology* and *geography* seem not improperly to have been called *the two eyes of history*. Besides, they very much assist the memory: for it is much easier to remember any thing said to be done at such a time, and in such a place, than if only related in general; nay, the remembrance of these often recalls those things to mind which otherwise had been obliterated. By *time* is meant not only the year of any particular era or period; but likewise the season, as summer or winter; and the age of particular persons. For it is oftentimes from hence that we are principally enabled to make a just estimate of facts. Thus Cicero commends Pompey for undertaking and finishing the Piratic war at a season of the year when other generals would not have thought it safe to venture out at sea. This double danger, as well from the weather as the enemy, considering the necessity of the case, heightens the glory of the action; since to have done the same thing in summer would not have been an equal proof of the courage and intrepidity of the general. And there is nothing more surprising in the conquests of Alexander than that he should subdue so large a part of the world by the time he was little more than 30 years old; an age at which few other generals have been much distinguished. Had we not known this, a considerable part of his character had been lost.

The like advantages arise from the other circumstances of *place*. And therefore in marches, battles, and other military actions, the historian should take notice of the nature of the country, the passes, rivers, distances of places, situation of the armies, and strength of the towns either by nature or art; from which the reader may the better form a judgment of the difficulties and greatness of any enterprise. Cæsar is generally very particular in these things, and seems to have thought it highly requisite in order to give his readers a just idea of his actions. The descriptions of countries, cities, and rivers, are likewise both useful and pleasant; and help us to judge of the probability of what is related concerning the temper and genius of the inhabitants, their arts, traffic, wealth, power, or whatever else is remarkable among them.

But an accurate historian goes yet further, and considers

Composi-
tion of
History.

Pro Leg.
Mem. c. 12.

Composi-
tion of
History.

considers the *causes* of actions, and what were the *designs* and views of those persons who were principally concerned in them. Some, as Polybius has well observed, are apt to confound the beginnings of actions with their springs and causes, which ought to be carefully separated. For the causes are often very remote, and to be looked for at a considerable distance from the actions themselves. Thus, as he tells us, some have represented Hannibal's besieging Saguntum in Spain, and passing the Ebro, contrary to a former agreement between the Romans and Carthaginians, as causes of the second Punic war. But these were only the beginnings of it. The true causes were the jealousies and fears of the Carthaginians from the growing power of the Romans; and Hannibal's inveterate hatred to them, with which he had been impressed from his infancy. For his father, whom he succeeded in the command of the Carthaginian army, had obliged him, when but nine years old, to take a most solemn oath upon an altar never to be reconciled to the Romans: and therefore he was no sooner at the head of the army, than he took the first opportunity to break with them. Again, the true springs and causes of actions are to be distinguished from such as are only feigned and pretended. For generally the worse designs men have in view, the more solicitous they are to cover them with specious pretences. It is the historian's business, therefore, to lay open and expose to view these arts of politicians. So, as the same judicious historian remarks, we are not to imagine Alexander's carrying over his army into Asia to have been the cause of the war between him and the Persians. That had its being long before. The Grecians had formerly two armies in Asia, one under Xenophon and the other commanded by Agesilaus. Now the Asiatics did not venture to oppose or molest either of these armies in their march. This made King Philip, Alexander's father, who was an ambitious prince, and aspired after universal monarchy, think it might be a practicable thing to make a conquest of Asia. Accordingly, he kept it in his view, and made preparations for it; but did not live to execute it. That was left for his son. But as King Philip could not have done this without first bringing the other states of Greece into it, his pretence to them was only to avenge the injuries they had all suffered from the Persians; though the real design was an universal government, both over them and the Persians, as appeared afterwards by the event. But in order to our being well assured of a person's real designs, and to make the accounts of them more credible, it is proper we should be acquainted with his disposition, manners, way of life, virtues, or vices; that by comparing his actions with these, we may see how far they agree and suit each other. For this reason Sallust is so particular in his description of Catiline, and Livy of Hannibal; by which it appears credible, that the one was capable of entering into such a conspiracy against his country, and the other of performing such great things as are related concerning him. But if the causes of actions lie in the dark, and unknown, a prudent historian will not trouble himself or his readers with vain and trifling conjectures, unless something very probable offers itself.

Lastly, an historian should relate the *issue* and *event* of the actions he describes. This is undoubtedly the

most useful part of history; since the greatest advantage arising from it is to teach us experience from what has happened in the world before us. When we learn from the examples of others the happy effects of wisdom, prudence, integrity, and other virtues, it naturally excites us to an imitation of them, and to pursue the same measure in our own conduct. And, on the contrary, by perceiving the unhappy consequences which have followed from violence, deceit, rashness, or the like vices, we are deterred from such practices. But since the wisest and most prudent measures do not always meet with the desired success, and many cross accidents may happen to frustrate the best concerted designs; when we meet with instances of this nature, it prepares us for the like events, and keeps us from too great a confidence in our own schemes. However, as this is not commonly the case, but in the ordinary course of human affairs like causes usually produce like effects; the numerous examples of the happy consequences of virtue and wisdom recorded in history are sufficient to determine us in the choice of our measures, and to encourage us to hope for an answerable success, though we cannot be certain we shall in no instance meet with a disappointment. And therefore Polybius very justly observes, that "he who takes from history the causes, manner, and end of actions, and omits to take notice whether the event was answerable to the means made use of, leaves nothing in it but a bare amusement, without any benefit or instruction." These, then, are the several things necessary to be attended to in historical narrations; but the proper disposition of them must be left to the skill and prudence of the writer.

II. *Reflections* made by the writers. Some have condemned these, as having a tendency to bias the reader; who should be left to draw such conclusions from the accounts of facts as he sees proper. But since all readers are not capable of doing this for themselves, what disadvantage is it for the author to suggest to them such observations as may assist them to make the best use of what they read? And if the philosopher is allowed to draw such inferences from his precepts as he thinks just and proper, why has not the historian an equal right to make reflections upon the facts he relates? The reader is equally at liberty to judge for himself in both cases, without danger of being prejudiced. And therefore we find, that the best historians have allowed themselves this liberty. It would be easy to prove this by a large number of instances, but one or two here may suffice. When Sallust has given a very distinct account of the designs of Catiline, and of the whole scheme of the conspiracy, he concludes it with this reflection: "All that time the empire of the Romans seems to me to have been in a very unhappy state. For when they had extended their conquests through the whole world from east to west, and enjoyed both peace and plenty, which mankind esteem their greatest happiness; some persons were obstinately bent upon their own ruin, and that of their country. For notwithstanding two decrees were published by the senate, not one out of so great a multitude was prevailed with, by the rewards that were offered, either to discover the conspiracy or to leave the army of Catiline. So desperate a disease, and as it were infection, had seized the minds of most people!" And it is a very handsome

Composi-
tion of
History.

87
Of reflections.

Bell. Catil.
c. 37.

observation.

Composi-
tion of
History.

Lib. xxiii.
c. 13.

observation that Livy makes upon the ill-conduct of Hannibal in quartering his army in Capua after the battle of Cannæ; by which means they lost their martial vigour through luxury and ease. "Those (says he) who are skilled in military affairs reckoned this a greater fault in the general, than his not marching his army immediately to Rome after his victory at Cannæ; for such a delay might have seemed only to defer the victory, but this ill step deprived him of the power to gain it." The modesty of the historian in this passage is worth remarking, in that he does not represent this as his own private opinion, and by that means undertake to censure the conduct of so great a general as Hannibal was, but as the sense of those who were skilled in such affairs. However, a historian should be brief in such remarks; and consider, that although he does not exceed his province by applauding virtue, expressing a just indignation against vice, and interposing his judgment upon the nature and consequences of the facts he relates; yet there ought to be a difference between his reflections and the encomiums or declamations of an orator.

83
Of speech-
cs.

III. *Speeches* inserted by historians. These are of two sorts, oblique and direct. The former are such as the historian recites in his own person, and not in that of the speaker. Of this kind is that of Hannibal in Justin; by which he endeavours to persuade King Antiochus to carry the seat of the war against the Romans into Italy. It runs thus: "Having desired liberty to speak, he said none of the present counsels and designs pleased him; nor did he approve of Greece for the seat of the war, which might be managed in Italy to greater advantage: because it was impossible to conquer the Romans but by their own arms, or to subdue Italy but by its own forces; since both the nature of those men, and of that war, was different from all others. In other wars, it was of great importance to gain an advantage of place or time, to ravage the countries and plunder the towns; but though you gain some advantage over the Romans, or defeat them, you must still fight with them when beaten. Wherefore, should any one engage with them in Italy, it was possible for him to conquer them by their own power, strength, and arms, as he himself had done; but should he attempt it out of Italy, the source of their power, he would be as much deceived, as if he endeavoured to alter the course of a river, not at the fountain-head, but where its streams were largest and deepest. This was his judgment in private, and what he had offered as his advice, and now repeated in the presence of his friends; that all might know in what manner a war ought to be carried on against the Romans, who were invincible abroad, but might be conquered at home. For they might sooner be driven out of their city than their empire, and from Italy than their provinces; having been taken by the Gauls, and almost subdued by himself. That he was never defeated till he withdrew out of their country; but upon his return to Carthage, the fortune of the war was changed with the place." He seems to intimate by this speech, that the Romans were like some fierce and impetuous animals, which are no otherwise to be subdued than by wounding them in some vital part. In speeches related after this manner, we are not necessarily to suppose the historian gives us

Lib. xxxi.
c. 5.

the very words in which they were at first delivered, but only the sense. But in direct speeches, the person himself is introduced as addressing his audience; and therefore the words as well as the sense are to be suited to his character. Such is the speech of Eumenes, one of Alexander's captains and successors, made to his soldiers when they had traitorously bound him in chains, in order to deliver him up to his enemy Antigonus, as we have it in the same writer. "You see, soldiers (says he), the habits and ornaments of your general, which have not been put upon me by mine enemies; that would afford me some comfort: it is by you, that of a conqueror I am become conquered, and of a general a captive; though you have sworn to be faithful to me four times within the space of a year. But I omit that, since reflections do not become persons in calamity. One thing I intreat, that, if Antigonus must have my life, you would let me die among you. For it no way concerns him how or where I suffer, and I shall escape an ignominious death. If you grant me this, I free you from your oath, with which you have been so often engaged to me. Or, if shame restrains you from offering violence to me at my request, give me a sword, and suffer your general to do that for you without the obligation of an oath which you have sworn to do for your general."

Composi-
tion of
History.

Lib. xiv.
c. 4.

But this likewise is a matter in which critics have been divided in their sentiments; whether any, or what kind of speeches ought to be allowed in history. Some have thought all speeches should be excluded: and the reason given for that opinion is this; that it breaks the thread of the discourse, and interrupts the reader, when he is desirous to come to the end of an action, and know how it issued. This is true, indeed, when speeches are either very long or too frequent; but otherwise they are not only entertaining, but likewise instructive. For it is of service to know the springs and reasons of actions; and these are frequently opened and explained in the speeches of those by whom they were performed. Others therefore have not been against all speeches in general, but only direct ones. And this was the opinion of Trogus Pompeius, as Justin informs us; though he did not think fit to follow him in that opinion, when he abridged him, as we have seen already by the speech of King Eumenes. The reason offered against direct speeches is, because they are not true; and truth is the foundation of all history, from which it never ought to depart. Such speeches, therefore, are said to weaken the credit of the writer; since he who will tell us that another person spoke such things which he does not know that he ever did speak, and in such language as he could not use, may take the same liberty in representing his actions. Thus, for example, when Livy gives us the speeches of Romulus, the Sabine women, Brutus, and others, in the first ages of the Roman state, both the things themselves are imaginary, and the language wholly disagreeable to the times in which those persons lived. Accordingly we find, that when several historians relate some particular speech of the same person, they widely differ both in the subject-matter and expressions. So the speech of Veturia, by which she dissuaded her son Coriolanus from besieging Rome when he came against it with an army

Lib. xxxviii.
c. 3.

of

Composi-
tion of
History.

Lib. ii.
c. 40.
Ant. Rom.
lib. viii.
c. 46.
In Corio-
lano.
See Voss.
Ant. Hist.
c. 10.

of Volscians to avenge the injuries he had received, is very differently related by Livy, Dionysius of Halicarnassus, and Plutarch. Such fictitious speeches therefore are judged more fit for poets, who are allowed a greater liberty to indulge their fancy than historians. And if any direct speeches are to be inserted, they should be such only as were really spoken by the persons to whom they are ascribed, where any such have been preserved. These have been the sentiments of some critics both ancient and modern. However, there is scarce an ancient historian now extant, either Greek or Latin, who has not some speeches, more or less, in his works; and those not only oblique, but also direct. They seem to have thought it a necessary ornament to their writings: and even where the true speeches might be come at, have chosen rather to give them in their own words; in order, probably, to preserve an equality in the style. Since therefore the best and most faithful historians have generally taken this liberty, we are to distinguish between their accounts of facts and their speeches. In the former, where nothing appears to the contrary, we are to suppose they adhere to truth, according to the best information they could get; but in the latter, that their view is only to acquaint us with the causes and springs of actions, which they choose to do in the form of speeches, as a method most ornamental to the work, and entertaining to the reader: Though the best historians are cautious of inserting speeches, but where they are very proper, and upon some solemn and weighty occasions. Thucydides is said to have been the first who brought complete and finished speeches into history, those of Herodotus being but short and imperfect. And though Dionysius of Halicarnassus, in his censure upon Thucydides, seems then to have disliked that part of his conduct; yet he afterwards thought fit to imitate it in his *Antiquities of Rome*, where we find many not only oblique, but also direct speeches.

What has been said of speeches, may likewise be understood of letters, which we sometimes meet with in histories; as that of Alexander to Darius in Quintus Curtius, those of Tiberius and Drusus in Tacitus, and many others. Some letters are wholly fictitious; and in others perhaps the historian represents the substance of what was really said, but gives it his own dress. Thus we find that short letter of Lentulus to Catiline at the time of his conspiracy differently related by Cicero and Sallust. The reason of which seems to be this: That as Cicero recited it publicly to the people of Rome in his third oration against Catiline, it is reasonable to imagine he did it in the very words of the letter, which he had by him; whereas Sallust, as an historian, might think it sufficient to give the sense of it in his own words.

IV. Digressions. These if rightly managed, afford the reader both delight and profit. Like speeches, they should neither be too long nor frequent; lest they interrupt the course of the history, and divert the reader from the main design of the work. But now and then to introduce a beautiful description, or some remarkable incident, which may give light to the subject, is so far from an interruption, that it is rather a relief to the reader, and excites him to go on with greater pleasure and attention. See further on this head, **ORATORY**, N^o 37.

ART. III. Of ORDER.

Composi-
tion of
History.
89
Of order.

Since most histories consist of an introduction and the body of the work, in each of which some order is requisite, we shall discuss them separately.

1. The design of the introduction is the same here as in orations. For the historian proposes three things by his introduction, which may be called its parts; to give his reader some general view of the subject; to engage his attention, and to possess him with a candid opinion of himself and his performance. Some have thought this last unnecessary for an historian. But if we consider how differently mankind are apt to judge of the same persons and actions, it seems as requisite for an historian to be well esteemed as an orator. And therefore we find some of the best historians have not omitted this part. Livy's introduction has been very much applauded by the learned, as a masterpiece in its kind. It begins with an account of his design. "Whether (says he) it may answer any valuable end for me to write the history of the Roman affairs from the beginning of the city, I neither am certain, nor if I was should I venture to declare it." Soon after he endeavours to prepare the reader's attention, by representing the grandeur and usefulness of the subject in the following words: "Either I am prejudiced in favour of my subject, or there never was any state greater, more virtuous, and fruitful of good examples, or in which avarice and luxury had a later admittance, or poverty and thriftiness were either more highly or longer esteemed, they always coveting less the less they enjoyed." And then he presently proceeds to ingratiate himself with his readers, and gain their favourable opinion: "Although my name is obscure in so great a number of writers, yet it is a comfort that they cloud it by their fame and character. But I shall gain this advantage by my labour, that I shall be diverted for a time from the prospect of those evils which the age has seen for so many years; while my mind is wholly intent upon former times, free from all that care which gives the writer an uneasiness, though it cannot bias him against the truth." In this passage we see he endeavours to gain the good esteem of his readers from two very powerful motives, modesty and a strict regard to truth. It may scarce seem necessary to observe, that those introductions are esteemed the best which are most natural; that is, such as are taken from the subject-matter of the history itself, and closely connected with it. Such are those of Herodotus, Thucydides, Livy, Tacitus, and others. And therefore Sallust is greatly blamed by Quintilian on the account of his introductions, which are so general that they might suit other histories as well as those to which they are prefixed. Introductions should likewise be proportioned to the length of the work. We meet with some few histories, in which the writers immediately enter upon their subject, without any introduction; as Xenophon in his Expedition of the younger Cyrus, and Caesar in his Commentaries of the Gallic and Civil Wars. But the latter does not profess to write a just history; and therefore left himself more at liberty, as well in this respect as in some others.

2. But order is principally to be regarded in the body of the work. And this may be managed two ways; either by attending to the time in a chronological

Lib. iv.
c. 1.
Ann. lib. i.
73. iii. 56,
59.

Composi-
tion of
History.

cal series, or the different nature and circumstances of the things contained in the history. However, as these two methods do not equally suit all subjects, we shall a little consider to what kind of histories each of them seems more properly adapted. All history then, as we have observed already, may be reduced to three sorts; *biography*, the *history of particular states*, and the *general history of several states* existing at the same time.

In biography, or the lives of particular persons, most writers follow the order of time; though some reduce them to certain general heads, as their virtues and vices, or their public and private character. Plutarch and Cornelius Nepos have taken the former method, and Suetonius the latter.

As to the history of particular states, the order of time is generally best, as being most natural and easy. And therefore it has usually been observed by the best historians, as Thucydides, Livy, and others. Tacitus, indeed, wrote two distinct works; one of which he called *Annals*, and the other *Histories*. And as in both he has kept to the order of time, critics have been at a loss to assign any other reason for these different titles, unless that in the former work he confines himself more closely to the facts themselves, and does not treat so largely upon the causes, manner, or event of them, as he has done in the latter. And even in the circumstances of facts, there is a certain order proper to be observed, for rendering the account more plain and intelligible. Thus, for instance, in the description of a battle or siege, the time should first be known, then the chief person or persons who conducted it, then the number of forces, and other requisites, afterwards the nature of the place, then the action itself, and lastly the event. But sometimes it is necessary to add the time in which several of the other circumstances happened, especially in actions of any considerable length. Where the order of these circumstances is confused, it perplexes the account, and renders it both less entertaining to the reader, and more difficult to remember.

In a general history, the order of time cannot always be preserved; though, where the actions of different communities have respect to one as the principal, they should all, as far as possible, be referred to the transactions of that state. But even here the several affairs of those different states ought to be related separately, which will necessarily occasion the anticipating some things, and postponing others, so that they cannot all stand in the order of time in which they were performed. However, Velleius Paterculus says very justly with regard to this subject, "That every entire action placed together in one view, is much better apprehended than if divided by different trifles." In this case, therefore, for better preserving the chronology, it is usual with historians, when they have finished any particular narrative, in passing to the next, to express the time by some short and plain transition; and sometimes to apologize for themselves, by assigning the reasons of their conduct. So Polybius, whose history is of this kind, says concerning himself: "As in writing the actions of each year, in the order of time, I endeavour to represent the affairs of the same nation together in one summary view, it is plain that inconvenience must of course attend this

way of writing." Curtius professes only to write the actions of Alexander king of Macedon; but his history contains in it the principal affairs of the greatest states in the world during that period. Now although, in the course of those transactions, the war between Archelaus governor of Macedonia, and Agis king of Sparta, happened before the battle of Alexander at Arbela; yet the historian not only relates that battle first, but carries on the account of Alexander's affairs in Asia to the death of Darius without interruption; for which he gives this reason: "If I should relate the affairs of Alexander, which happened in the mean time, either in Greece or Illyricum and Thrace, each in their proper order and time, I must interrupt the affairs of Asia; which it is much better to represent together in one continued series as they fell out, to the flight and death of Darius." Such anachronisms, therefore, are nothing more than what necessarily arise sometimes from the nature of the subject: As every thing, the more complex it is, and contains under it a great number of parts, is more difficult to be digested in a regular order. But in a history composed of several states, whose affairs are independent of one another, the actions of each nation must necessarily be separated, in order to represent them in a just view, and prevent confusion. This is the method which Herodotus has taken, as likewise Diodorus Siculus and Justin. Now both the pleasure and benefit which such histories afford, arise from observing the conduct of each state separately in the course of their affairs, and then comparing one with the other. And as the order of time must frequently be interrupted, it is not unusual to continue the chronology at proper distances in relating the affairs of each nation; which preserves an unity in the whole, and connects it in one consistent body.

The division of histories into books was designed only for the better distinction of the subject and ease of the reader. And the dividing these books again into chapters, is rather a practice of latter editors (founded, as they have thought, on the same reasons), than countenanced by the example of ancient writers.

ART. IV. Of STYLE.

An historical style is said to be of a middle nature, between that of a poet and an orator, differing from both not only in the ornamental parts, but likewise in the common idioms and forms of expression.

Cicero observes, that "nothing is more agreeable in history than brevity of expression, joined with purity and perspicuity." Purity indeed is not peculiar to history, but yet it is absolutely necessary; for no one will ever think him fit to write a history who is not master of the language in which he writes: and therefore when Albinus had written a history of the Roman affairs in Greek, and apologised for any slips or improprieties that might be found in the language upon the account of his being a Roman, Cato called him a trifler, for choosing to do that which, after he had done it, he was obliged to ask pardon for doing. Nor is perspicuity less requisite in an historical style. The nature of the subject plainly directs to this. For as history consists principally in narration, clearness and perspicuity are nowhere more necessary than in a relation of facts.

But

mpoi. But these two properties are to be accompanied with
oa of brevity, since nothing is more disagreeable than a long
istory. and tedious narrative. And in this respect an histori-
cal style differs both from that of poetry and oratory.
For the poet frequently heightens and enlarges his de-
scriptions of facts, by dwelling upon every circumstance,
placing it in different views, and embellishing it with
the finest ornaments of wit and language, to render his
images more agreeable; and the orator often does the
like, with a design to strike the passions. But such col-
ouring is not the business of an historian, who aims at
nothing more than a just and faithful representation of
what he relates, in a way best suited to its nature, and
in such language as is most proper to set it in a plain
and easy light.

Orat. Again, Cicero, treating of an historical style, says:
ii. "It ought to be fluent, smooth, and even, free from
5. 22. that harshness and poignancy which is usual at the
bar." The properties here mentioned distinguish this
style from that of judicial discourses, in which the ora-
tor often finds it necessary to vary his manner of speak-
ing, in order to answer different views, either of pursu-
ing an argument, pressing an adversary, addressing a
judge, or recommending the merits of his cause. This
occasions an inequality in his style, while he speaks
sometimes directly, at other times by way of question,
and intermixes short and concise expressions with round
and flowing periods. But the historian has no necessity
for such variations in his style. It is his province
to espouse no party, to have neither friend nor foe, but
to appear wholly disinterested and indifferent to all;
and therefore his language should be smooth and equal
in his relations of persons and their actions.

t. ad But further: Dionysius makes "decey a princi-
Pom- pal virtue in an historian;" which he explains by say-
ing, that "he ought to preserve the characters of the
persons and dignity of the actions of which he treats."
And to do this it seems necessary that an historical
style should be animated with a good degree of life and
vigour; without which neither the characters of emi-
nent persons, nor their remarkable actions, which make
up the main business of history, can be duly represent-
ed: for even things in themselves great and excellent,
if related in a cold and lifeless manner, often do not
affect us in a degree suitable to their dignity and im-
portance. And this seems particularly necessary in
speeches, in order to represent what every one says, ac-
cording to his different country, age, temper, and sta-
tion of life, in the same manner we may suppose he
either really did, or would have spoken himself on that
occasion. Besides there are some scenes of action which
require very pathetic and moving language to repre-
sent them agreeably to their nature. And in descrip-
tions, the most beautiful tropes and lively figures are
often necessary to set the ideas of things in a proper
light. From whence it appears, that painting and ima-
gery make up no small part of the historian's province,
though his colours are not so strong and glittering as
those either of the poet or orator. He ought therefore
to be well acquainted with the manners of men and the
nature of the passions, since he is often obliged to de-
scribe both; in the former of which Herodotus ex-
ceeds, and Thucydides in the latter, as Dionysius has ob-
served.

VOL. X. Part II.

+

Now from these several properties laid down by an-
cient writers, as requisite for an historical style, it seems
upon the whole to agree best with the middle charac-
ter. And this will further appear, by what they say
relating to the ornamental parts of style; namely, com-
position and dignity. As to the former of these, which
respects the structure of sentences, and the several parts
of them, Demetrius remarks, that "An historical pe-
riod ought neither to rise very high, nor sink very low,
but to preserve a medium." This simplicity (he says)
"becomes the gravity and credit of history; and dis-
tinguishes it from oratory on the one hand, and dia-
logue on the other." His meaning is, that historical
periods should neither be so full and sonorous as is fre-
quent in oratory: nor yet so short and flat as in dia-
logue: the former of which, as he says, require a strong
voice to pronounce them; and the latter have scarce
the appearance of periods. So that, according to this
judicious writer, the periods best suited for history are
those which, being of a moderate length, will admit of
a just rise and cadency, and may be pronounced with
ease. And Dionysius tells us, that "History should
flow smooth and even, everywhere consistent with itself,
without roughness or chasms in the sound." This re-
lates to the harmony of periods, which arises from such
a position of the words as renders the sound pleasant
and agreeable, and as he thinks ought to be attended
to in history. And as to dignity, which respects the
use of tropes and figures, the same author says, that
"History should be embellished with such figures as
are neither vehement nor carry in them the appearance
of art." This is agreeable to what Cicero observes, in
comparing Xenophon and Calisthenes, two Greek his-
torians. "Xenophon the Socratic (says he) was the
first philosopher, and after him Calisthenes the scholar
of Aristotle, who wrote an history: the latter almost
like a rhetorician: but the style of the former is more
moderate, and has not the force of an orator, less vehe-
ment perhaps, but in my opinion more sweet and plea-
sant." The difference between these two writers, with
De Orat. regard to their style, consisted chiefly in the choice of lib. ii.
their figures: which in Xenophon were more gentle⁶. 14
and moderate, and therefore in the judgment of Cicero
more agreeable to history. Now these several prop-
erties relating to the ornaments of language, as well as
those before mentioned, which by ancient writers have
been thought requisite for history, are all suited to the
middle style, as we have elsewhere shown at large. See
ORATORY, N^o 99—121.

But notwithstanding this general account of the se-
veral properties which constitute an historical style, it
admits of considerable varieties from the different na-
ture and dignity of the subject. The lives of particu-
lar persons do not require that strength and majesty of
expression, nor all those ornaments of language, as
an history of the Roman empire. And accordingly
we find the style of Nepos and Suetonius very differ-
ent from that of Livy. The former is smooth and
easy, scarce rising above the low character; but the
latter often approaches near to the sublime. And
other historians again have kept a medium between
these. Upon the whole, therefore, we may conclude,
that the middle style is the proper character for his-
tory; though historians may sometimes sink into the

3 Z

low

Composi-
tion of
History.

low character, and at other times rise to the grandeur and magnificence of the sublime, from the different nature of their subject, or some particular parts of it. For that is to be esteemed the proper character of any writing which in the general best suits it. And this distinction may help us in some measure to

reconcile the sentiments of writers upon this head, who seem to attribute different characters to an historical style, or at least to judge where the truth lies; since a variety of style is not only requisite in different subjects, but likewise in different parts of the same work.

Composi-
tion of
History.

H I T

History
Hith.

HISTORY of Nature, or Natural History. See NATURAL HISTORY.

HISTRIO, in the ancient drama, signified an actor or comedian; but more especially a pantomime, who exhibited his part by gestures and dancing. Livy informs us that the histriones were brought to Rome from Etruria, in the year of the city 391, (Dec. i. lib. 7.).

HISTRIX. See **HYSTRIX**.

HITCHING, a large and populous town of Hertfordshire in England, situated near a large wood called *Hitchwood*. The manor was the ancient demeane of the kings of England, as it continues at this day; and it has been the dower of several of their queens. The town is reckoned the second in the county for number of streets, houses, and inhabitants. It was formerly famous for the staple commodities of the kingdom, and divers merchants of the staple of Calais resided here, since which that trade is lost. The inhabitants now make large quantities of malt; and the market is one of the greatest in England for wheat. Population 3608. W. Long. 0. 10. N. Lat. 51. 58.

HITHE, or **HUTHE**, a town of Kent in England, 70 miles from London. It is one of the cinque ports; and had formerly five parishes, but by the choking up of its harbour and other accidents is now reduced to one. In the reign of Henry IV. numbers of its inhabitants were cut off by a pestilence, 200 of their houses consumed by fire, and five of their ships sunk at sea, with the loss of 100 men; so that the people were going to abandon the town, had not the king by his charter generously released to them, for five turns next following, their service of five ships of 100 men and five horse, which they were to have furnished out and kept at their own charge in the king's wars for 15 days. It was first incorporated by the name of *barons of the town and port of Hith*; but the government was afterwards changed. It was incorporated by Queen Elizabeth with the name of the mayor, jurats, and commonalty of the town and port of Hith, who with the freemen elect the members of parliament. The mayor is chosen yearly on Candlemas-day. Here is a market on Saturdays, and fairs in July and December. From hence to Canterbury is a paved Roman military way, called *Stoney Street*; and at a little distance from hence are the remains of the walls of a castle, which included 10 acres. There is a remarkable pile of dry bones in the town, 28 feet long, 6 broad, and 8 high; they are kept in a vault under the church in as good order as books in a library, consisting of several thousand heads, arms, legs, thigh-bones, &c. some very gigantic, and appear by an inscription to be the remains of the Danes and Britons killed in a battle near this place, before

H O A

Hithe
Hoadley.

the Norman conquest. From hence to Boulogne is reckoned the shortest cut to France. Population 2318 in 1811. E. Long. 1. 10. N. Lat. 51. 8.

HITTITES, the descendants of Heth. See **HETH**.

HIVE, in country affairs, a convenient receptacle for bees. See **APIS** and **BEE**.

HIVITES, a people descended from Canaan. They dwelt at first in the country which was afterwards possessed by the Caphtorims, or Philistines. There were Hivites likewise at Shechem and Gibeon, and consequently in the centre of the promised land; for the inhabitants of Shechem and the Gibeonites were Hivites, (Joshua xi. 19. Genesis xxxiv. 2.). Lastly, there were some beyond Jordan, at the foot of Mount Hermon (Joshua xi. 3.). Bochart is of opinion, that Cadmus, who carried a colony of Phœnicians into Greece, was an Hivite. His name, *Cadmus*, comes from the Hebrew *Keden*, "the east," because he was of the eastern part of the land of Canaan. The name of his wife *Hermione*, comes from Mount Hermon, at the foot whereof the Hivites had their dwelling. The metamorphosis of Cadmus's companions into serpents is grounded on the signification of the name *Hivites*, which in Phœnician signifies "serpents."

HOACHE, in *Natural History*, a kind of earth approaching to the nature of chalk, but harder, and feeling like soap; whence some think that it is either the same with the soap-rock of Cornwall, or very like it. The Chinese mix it with water till the liquor is of the consistence of cream, and then varnish their china-ware with it.

HOADLEY, BENJAMIN, successively bishop of Bangor, Hereford, Salisbury, and Winchester, was born in 1676. His first preferment in the church was the rectory of St Peter le Poor, and the lectureship of St Mildred's in the Poultry. In the year 1706, he published some Remarks on the late Bishop Atterbury's sermon at the funeral of Mr Bennet, in which Dr Atterbury had, in the opinion of Mr Hoadley, laid down some dangerous propositions. Two years after, Mr Hoadley again entered the lists against this formidable antagonist; and in his *exceptions* against a sermon published by Dr Atterbury, intitled "The Power of Charity to Cover Sin," he attacked the doctor with his usual strength of reasoning and dispassionate inquiry. In 1709, another dispute arose between these two learned combatants, concerning the doctrine of non-resistance, occasioned by a performance of Mr Hoadley's, intitled "The Measures of Obedience;" some positions in which Dr Atterbury endeavoured to confute in his elegant Latin sermon preached that year before the London clergy. In this debate Mr Hoadley signalized himself in so eminent a degree, that

HISTORICAL
Representing at one view the rise and progress of the Principal States & Empires of the known World.

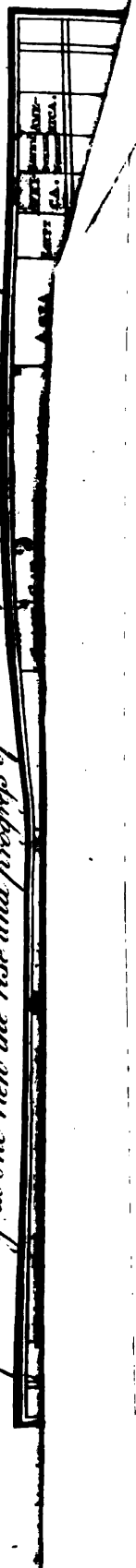

nia Hoadley
as Hobbes.
m-
ds
ly-
tal
id-
de
nd
so-
He
to.
ya-
ra-
ar-
ice
in
nd
al,
on.
l of
po-
nd
ive
ho
ro-
ler
nd
[n-
he
ity
he
ee
nt
ed
at
);
f-
n-
ce
p-
e-
ed
y-
nd
is
ch
le
ir
d
le
f-
it
d
s.
d
n
r

Composi- low
tion of det
History. fer
of
ter
An

History
|
Hithe. } TU

tor
exb
fori
fro:
lib.

for
Hi
the
it l
tov
of
far
div
sin
ms
of
W

7c
an
its
It
w
st
th
a
g
it
h
a
I
v
h
a
r
e
i
l
i
i

Hoadley. that the honourable house of commons gave him a particular mark of their regard, by representing, in an address to the queen, the signal services he had done to the cause of civil and religious liberty.—The principles, however, which he espoused being repugnant to the general temper of those times, drew on him the virulence of a party; yet it was at this period (1710, when, as he himself expressed it, *fury seemed to be let loose upon him*) that the late Mrs Howland presented him to the rectory of Streatham in Surry, unasked, unapplied to, and without his either having seen her or been seen by her. Soon after the accession of King George I. Mr Hoadley was consecrated to the see of Bangor; and, 1717, having broached some opinions concerning the nature of Christ's kingdom, &c. he again became the object of popular clamour. At this juncture he was distinguished by another particular mark of the royal regard, by means of which the convocation was successively prorogued, and it was not permitted to sit, or do any business, till that resentment was entirely subsided. In 1721 he was translated to Hereford; and from thence, in 1723, to Salisbury. In 1734, he was translated to Winchester (on the demise of Dr Willis), and published his *Plain Account of the Sacrament*: a performance which served as a butt for his adversaries to shoot at; yet impartiality owns it to be clear, rational, and manly, written with great candour and judgment, and suited to the capacity of every serious and considerate inquirer after truth.—His latter days were embittered by a most vile instance of fraud and ingratitude. The bishop took a French priest, who pretended to abjure his religion, under his protection, with no other recommendation than that of his necessities; in return for which act of humanity, the priest found an opportunity of getting the bishop's name written by his own hand, and, causing a note of some thousand pounds to be placed before it, offered it in payment. But the bishop denying it to be his, it was brought before a court of justice, and was there found to be a gross imposition. The ungrateful villain had now recourse to a pamphlet, in which he charged the bishop with being a drunkard; and alleged that he had the note of him when he was in liquor. To this calumny the bishop made a full and nervous answer; in which he exposed the man's falsehood, and solemnly averred that he was never drunk in his whole life. The world with becoming ardour embraced his defence, and he had the happiness to find himself perfectly acquitted even of any suspicion of such a charge. As a writer, he possessed uncommon abilities. His sermons (published in 1754 and 1755) are esteemed inferior to few writings in the English language, for plainness and perspicuity, energy and strength of reasoning, and a free and masterly manner. In private life, he was naturally facetious, easy, and complying; fond of company, yet would frequently leave it for the purposes of study or devotion. He was everywhere happy; and particularly in his own family, where he took all opportunities of instructing by his influence and example. He died in 1761, aged 83. Besides the works already mentioned, he wrote, 1. *Terms of Acceptance*, 8vo. 2. *Reasonableness of Conformity*. 3. *On the Sacrament*. His tracts and pamphlets are extremely numerous: and the reader may see a complete catalogue of them in

his life inserted in the supplement to the *Biographia Britannica*.

HOADLEY, Benjamin, M. D. son of the former, was born in 1706; and studied at Bennet college, Cambridge, under the tuition of Dr Herring, afterwards archbishop of Canterbury. He took his degree in physic; and particularly applying himself to mathematical and philosophical studies, was, when very young, admitted a member of the royal society. He was made register of Hereford while his father filled that see, and was early appointed physician to his majesty's household, but died at his house in Chelsea in 1757. He wrote, 1. Three letters on the organs of respiration, 4to. 2. *The Suspicious Husband*, a comedy. 3. Observations on a series of electrical experiments; and, 4. *Oratio anniversaria, in Theatro Col. Med. Londin. ex Harveri instituto habita die Octob. 1742*.

HOAI-NGAN-FOU, a city of China, in the province of Hiang-nan. According to Grosier, it is situated in a marsh, and is enclosed by a triple wall. As the ground on which it stands is lower than the bed of the canal, the inhabitants live in continual dread of an inundation. The suburbs extend to the distance of a league on each side of the canal, and form at their extremity a kind of port on the river Hoang-ho. This place is very populous, and every thing in it announces an active and brisk trade. One of those great mandarins who have the inspection of the canals and navigation, and who are also obliged to supply the court with necessary provisions, resides here. This city has eleven others under its jurisdiction; two of which are of the second, and nine of the third class.

HOAR-HOUND. See **MARRUBIUM**, **BOTANY Index**.

HOARSENESS, in *Medicine*, a diminution of the voice, commonly attended with a preternatural asperity and roughness thereof. The parts affected are the aspera arteria and larynx. For its causes and cure, see **MEDICINE Index**.

HOBAL, in *Mythology*, an idol of the ancient Arabs, the worship of which at Mecca was destroyed by Mahomet.

HOBBS, THOMAS, a political writer, was born at Malmesbury in 1588. He was the son of a clergyman; and having completed his studies at Oxford, he was afterwards governor to the eldest son of William Cavendish earl of Devonshire. He travelled through France and Italy with that young nobleman, and at length applied himself entirely to the study of polite literature. He translated Thucydides into English; and published his translation in 1628, in order to show his countrymen, from the Athenian history, the disorders and confusions of a democratical government. In 1626 his patron the earl of Devonshire died; and in 1628 his son died also; which loss affected Mr Hobbes to such a degree, that he very willingly accepted an offer made him of going abroad a second time with the son of Sir Gervase Clifton; whom he accordingly accompanied into France, and staid there some time. But while he continued there, he was solicited to return to England, and to resume his concern for the hopes of that family to whom he had attached himself so early, and to which he owed so many and so great obligations. In 1631, the countess dowager of Devonshire desired to put the young earl under his care, who was then

Hoadley
Hobbes.

Hobbes.

about the age of 13. This was very suitable to Mr Hobbes's inclinations, who discharged that trust with great fidelity and diligence. In 1634, he republished his translation of Thucydides, and prefixed to it a dedication to that young nobleman, in which he gives a great character of his father, and represents in the strongest terms the obligations he was under to that illustrious family. The same year he accompanied his noble pupil to Paris, where he applied his vacant hours to the study of natural philosophy, and more especially to the perfect understanding of mechanism, and the causes of animal motion. He had frequent conversations upon these subjects with Father Marin Mersenne; a man deservedly famous, and who kept up a correspondence with almost all the learned in Europe. From Paris he attended his pupil into Italy, where at Pisa he became known to that great astronomer Galileo Galilei, who communicated to him his notions very freely; and after having seen all that was remarkable in that country, he returned with the earl of Devonshire into England. Afterwards, foreseeing the civil war, he went to seek a retreat at Paris; where, by the good offices of his friend Father Mersenne, he became known to the famous Renatus des Cartes, and afterwards held a correspondence with him upon several mathematical subjects, as appears from the letters of Mr Hobbes published in the works of Des Cartes. But when this philosopher printed afterwards his *Meditations*, wherein he attempted to establish points of the highest consequence from innate ideas, Mr Hobbes took the liberty of dissenting from him; as did also the French king's mathematical professor, the illustrious Peter Cassendi, with whom Mr Hobbes contracted a very close friendship, which was not interrupted till the death of the former. In 1642, Mr Hobbes printed a few copies of his famous book *De Cive*, which, in proportion as it became known, raised him many adversaries, who charged him with instilling principles which had a dangerous tendency. Among many illustrious persons who, upon shipwreck of the royal cause, retired to France for safety, was Sir Charles Cavendish, brother to the duke of Newcastle; and this gentleman, being skilled in every branch of the mathematics, proved a constant friend and patron to Mr Hobbes; who, by embarking in 1645 in a controversy about squaring the circle, was grown so famous for it, that in 1647 he was recommended to instruct Charles prince of Wales, afterwards King Charles II. in mathematical learning. His care in the discharge of this office gained him the esteem of that prince in a very high degree: and though he afterwards withdrew his public favour to Mr Hobbes on account of his writings, yet he always retained a sense of the services he had done him; showed him various marks of his favour after he was restored to his dominions; and, as some say, had his picture hanging in his closet. This year also was printed in Holland, by the care of M. Sorbier, a second and more complete edition of his book *De Cive*; to which are prefixed two Latin letters to the editor, the one by Mr Cassendi, the other by Father Mersenne, in commendation of it: and in 1650 was published at London a small treatise of Mr Hobbes's, entitled *Human Nature*; and another *De corpore politico*, or "Of the elements of the law."

All this time Mr Hobbes had been digesting with

Hobbes.

great care and pains his religious, political, and moral principles, into a complete system, which he called the *Leviathan*, and which was printed in English at London in 1650 and 1651. After the publication of his *Leviathan* he returned to England, and passed the summer commonly at his patron the earl of Devonshire's seat in Derbyshire, and some of his winters in town, where he had for his intimate friends some of the greatest men of the age. In 1660, upon the Restoration, he quitted the country, and came up to London, where he obtained from the king assurance of protection, and had an annual pension of 100l. settled upon him out of the privy purse. Yet this did not render him entirely safe: for, in 1666, his *Leviathan* and his treatise *De Cive* were censured by parliament; which alarmed him very much, as did also the bringing in of a bill into the house of commons to punish atheism and profaneness. When this storm was a little blown over, he began to think of procuring a beautiful edition of his pieces that were in Latin; but finding this impracticable in England, he caused it to be undertaken abroad, where they were published in quarto in 1668, from the press of John Bleau. In 1669, he was visited by Cosmo de Medicis, then prince, afterwards duke of Tuscany, who gave him ample marks of his esteem and respect; and having received his picture, and a complete collection of his writings, caused them to be repositied, the former among his curiosities, the latter in his noble library at Florence. The like visits he received from foreign ambassadors and other strangers of distinction; who were curious to see a person whose singular opinions and numerous writings had made so much noise all over Europe. In 1672, he wrote his own life in Latin verse, when, as he observes, he had completed his 84th year: and, in 1674, he published in English verse four books of Homer's *Odyssey*; which was so well received, that it encouraged him to undertake the whole *Iliad* and *Odyssey*, which he likewise performed and published in 1675. About this time he took his leave of London, and went to spend the remainder of his days in Derbyshire: where, however, he did not remain inactive, notwithstanding his advanced age; but published from time to time several pieces, to be found in the collection of his works. He died in 1679, aged 92.

As to his character and manners, they are thus described by Dr White Kennet, in his *Memoirs of the Cavendish family*. "The earl of Devonshire (says he) for his whole life entertained Mr Hobbes in his family, as his old tutor rather than as his friend or confidant. He let him live under his roof in ease and plenty, and in his own way, without making use of him in any public, or so much as domestic affairs. He would frequently put off the mention of his name, and say, 'He was a humorist, and nobody could account for him.' There is a tradition in the family, of the manners and customs of Mr Hobbes, somewhat observable. His professed rule of health was to dedicate the morning to his exercise, and the afternoon to his studies. And therefore, at his first rising, he walked out, and climbed any hill within his reach; or if the weather was not dry, he fatigued himself within doors by some exercise or other, to be in a sweat: recommending that practice upon this opinion, that an old man had more moisture than heat, and therefore by such

Hobbes,
Hobby.

such motion heat was to be acquired and moisture expelled. After this, he took a comfortable breakfast; and then went round the lodgings to wait upon the earl, the countess, and the children, and any considerable strangers, paying some short addresses to all of them. He kept these rounds till about 12 o'clock, when he had a little dinner provided for him, which he ate always by himself without ceremony. Soon after dinner he retired to his study, and had his candle with 10 or 12 pipes of tobacco laid by him; then shutting his door, he fell to smoking, thinking, and writing for several hours. He retained a friend or two at court, and especially the lord Arlington, to protect him if occasion should require. He used to say, that it was lawful to make use of ill instruments to do ourselves good: 'If I were cast (says he) into a deep pit, and the devil should put down his cloven foot, I would take hold of it to be drawn out by it.' After the Restoration, he watched all opportunities to ingratiate himself with the king and his prime ministers; and looked upon his pension to be more valuable, as an earnest of favour and protection, than upon any other account. His future course of life was to be free from danger. He could not endure to be left in an empty house. Whenever the earl removed, he would go along with him, even to his last stage, from Chatsworth to Hardwick. When he was in a very weak condition, he dared not to be left behind, but made his way upon a feather-bed in a coach, though he survived the journey but a few days. He could not bear any discourse of death, and seemed to cast off all thoughts of it. He delighted to reckon upon longer life. The winter before he died, he made a warm coat, which he said must last him three years, and then he would have such another. In his last sickness his frequent questions were, 'Whether his disease was curable? and when intimations were given, that he might have ease, but no remedy, he used this expression, 'I shall be glad to find a hole to creep out of the world at;' which are reported to have been his last sensible words; and his lying some days following in a silent stupefaction, did seem owing to his mind more than to his body.

The reverend Mr Granger observes, that Hobbes's style is incomparably better than that of any other writer in the reign of Charles I. and was for its uncommon strength and purity scarcely equalled in the succeeding reign. "He has in translation (says he) done Thucydides as much justice as he has done injury to Homer; but he looked upon himself as born for much greater things than treading in the steps of his predecessors. He was for striking out new paths in science, government, and religion; and for removing the land-marks of former ages. His ethics have a strong tendency to corrupt our morals, and his politics to destroy that liberty which is the birthright of every human creature. He is commonly represented as a sceptic in religion, and a dogmatist in philosophy; but he was a dogmatist in both. The main principles of his Leviathan are as little founded in moral or evangelical truths, as the rules he has laid down for squaring the circle are in mathematical demonstration. His book on human nature is esteemed the best of his works."

HOBBY, the name of a hawk called by some authors *subbutco*. See **FALCO**, **ORNITHOLOGY** *Index*.

It is a hawk of the lure, and not of the fist; and is very like the saker, only much less. It makes excellent sport with net and spaniels; for when the birds see the hobby, they dare not commit themselves to the wing, but lie close to the ground, and so are taken in nets.

HOBBY is also a name formerly given to strong active horses of a middling size: they are reported to have been originally natives of Ireland, and were much liked and used. Nags answer the same description as to size, qualities, and employments.

HOBGOBLIN, is a name vulgarly applied to fairies or apparitions. Skinner calls the word *robgooblins*, and derives it from Robin Goodfellow, Hob being the nick-name of Robin: but Wallis and Junius, with greater probability, derive it from *hoppgooblins*, *empusæ*, because they are supposed to hop without moving both their feet.

HOBLERS, or **HOBILERS**, *Hobelarii*, in our ancient customs, were men who, by their tenure, were obliged to maintain a light horse or hobby, for the certifying any invasion towards the sea-side.—The name was also used for certain Irish knights, who used to serve as light horsemen upon hobbies.

HOB-NAIL, a nail with a thick strong head, used in shoeing a hobby or little horse.

HOB-NOB, or **HAB-NAB**, a cant word formed from *hap ne hap*, and denoting an event which happens at random or by mere chance.

HOBOO, a name given by the people of Otabeite, and in the neighbouring islands of the South sea, to their superfine cloth. It is the thinnest and most finished preparation of the aouta.

HOBSSHEE COFFREES, a kind of Abyssinian slaves very frequent in the empire of Hindostan. They come mostly from a province subject to the Negus of Ethiopia, called Innariah, to the south of his other dominions, and bordering upon Negroland in Africa; from whence they are selected, and a great traffic made of them over all Mogolistan and Persia; but it is chiefly from the ports of Arabia and the Red sea that they are brought. Nothing can be imagined more smooth and glossy, and perfectly black, than their skin; in which they far surpass the negroes on the coast of Guinea; and, generally speaking, have not any thing of their thick lips, though otherwise as woolly haired as they. They are highly valued for their courage, fidelity, and shrewdness; in which they so far excel, as often to rise to posts of great honour, and are made governors of places under the title *Siddees*.

HOBSON'S CHOICE, a vulgar proverbial expression, applied to that kind of choice in which there is no alternative. It is said to be derived from the name of a carrier at Cambridge, who let out hackney horses, and obliged each customer to take in his turn that horse which stood next the stable door.

HOICHE, **LAZARUS**, a republican French general. This extraordinary man, and particular favourite of fortune, was born on the 24th of June 1768, at the village of Montreuil, in the suburbs of Versailles. His father, in the early part of his life, had been a soldier; but acted afterwards in the capacity of a menial servant, and was appointed to feed the hounds of Louis XV. His mother died soon after the birth of young Hoiche, by which he was left in a great measure destitute,

Hobby
Hoche.

Hoche.

tute, his aged father (then about 72) being unable to contribute to his support. By the humanity of an aunt, however, who kept a green stall at Versailles, he was rescued from absolute beggary. She sent him to a small school, where he acquired a tolerable knowledge of reading and writing, shewing himself at once the best and most mischievous scholar in the whole school. He was made a chorister by the rector of St Germain-en-Laye, because he found him to be a boy of a very lively disposition. He very soon discovered an insatiable thirst for information upon every subject, asking questions at those who were much older than himself, and listening with the utmost attention to the answers they returned. The ingenuity of his remarks and inquiries was often perplexing to others; but as he gradually approached towards manhood, a very remarkable change took place, both in his manners and disposition. His loquacity was succeeded by a musing, contemplative turn, and he proved by the importance of his conversation, that he had not meditated in vain.

Finding that his wants grew more numerous than could be supplied by the industry of his aunt, he formed the commendable resolution of earning his own subsistence, and accordingly became a sort of assistant in the royal stables of Versailles. His ardent character, however, soon found this situation by far too degrading; he already viewed it with abhorrence; and having accidentally met with some part of the works of Rousseau, a spirit of independence instantly seized upon him. Apprehending that he might better his situation by going abroad, to which he was strongly urged by a rascal who made a prey of him, even offered him money to enable him to prosecute the undertaking, and then gave him to understand that he was now a soldier in the French guards. Hoche, finding it wholly unavailing to remonstrate, was sent at the age of 16 to join his regiment, which was then quartered at Paris. Here he found himself possessed of no more than 125 livres (about 5l. sterling), the united result of his own economy, and the bounty he received on entering the army. Even out of this small sum he was obliged to treat his fellow soldiers with a breakfast, which exhausted his whole stock. A military life, however, soon appeared to be exactly suited to his disposition, so that he surpassed all the other recruits in the rapidity with which he learned the manual exercise; and in a single month was fit for the veteran ranks.

His limbs were admirably proportioned, his dress was always neat, and his conduct so regular, that he was made a grenadier at the request of the company. He now felt the circumscribed nature of his education, of which he was ashamed, and he determined to achieve that by his own exertions which the penury of his relations prevented them from accomplishing. He saw the necessity of a command of books, and as his pay was inadequate to the purchase of these, he determined to make up the deficiency by manual labour, with no species of which was he ever disgusted, while it put the means of intellectual improvement within his reach. He rose at the dawn of day, either to draw water, or trench ground for the gardeners in the vicinity of Paris; and at night he embroidered vests and caps.

The fruits of his industry were, at the end of the week, divided into three parts; the first was given to

the substitute who mounted guard for him; the second was devoted to the incidental expences of a convivial hour with his companions; and the third defrayed the expences of the books which he borrowed. He now turned his whole attention to the attainment of a better knowledge of his own profession, and even ventured to point out the radical defects of the prevailing system of military tactics, and reprobated some of the regulations which obtained in the army. In spite, however, of the general gravity of his deportment, he was no enemy to occasional conviviality. Having once understood that a companion had been murdered during a quarrel in the vicinity of the metropolis, he determined not to sleep till he had taken vengeance on the assassin. Marching forth at the head of a body of his companions, to the house where the deed was perpetrated, he demolished all the windows, and destroyed the furniture; but for this he was sentenced to three months confinement in the *black hole*. At the expiration of this period he exhibited a spectacle truly deserving of commiseration, being destitute of linen, clothes and shoes, his face pale and disfigured, and in this condition he arrived at the barracks, where he was received by his companions with every demonstration of joy. He soon after fought a duel with a tyrannical corporal, of whom the whole regiment was afraid except the gallant Hoche. The latter fell, and Hoche received a deep cut in his forehead, which added greatly to his martial appearance.

Soon after this period appeared the celebrated pamphlet of Sieyes respecting the *Third Estate*, and almost every Frenchman was ready to prove that he belonged to it. The guards, it is well known, took a decided part with the people; and on the 14th of July 1789, Hoche, at the head of his companions, was among the first who seized on the Bastile. The guards were formed into the 102d, 103d, and 104th regiments, into the last of which Hoche was admitted with the rank of second adjutant, when he had an opportunity of manifesting his talents in a different channel. Improper hands having obtained the administration of the military hospital of the French guards, he minutely investigated the state of the accounts, which had been veiled with ambiguity for the purpose of deceiving. He amended the discipline of the army, and his active talents did not pass unrewarded. While the regiment was reviewed in the Elysian fields, Servan, the minister at war, was so delighted with the platoons of Hoche's company, that he enquired who the young man was by whom it was conducted, and he bestowed on him some flattering compliments, and in four days after sent him the *brevet of lieutenant* in the regiment of Rouergue. He left Paris on the 24th of June 1792, in order to join his regiment, then in garrison at Thionville. General Leveneur, who held the command in the absence of Valence, sent Lieutenant Hoche with a regiment of hussars, to procure provisions for the troops which Miranda had ordered to lay siege to Maestricht. This he executed with universal applause; and when the army of the Ardennes was ordered to recross the Meuse, Hoche succeeded in removing the powder from the abbey of Merchen, in bringing away the military chest of the division, and conducting the sick in the hospital, when every thing appeared to be in the power of the enemy's hussars. Having fought in the capacity of *aide-de-camp* to General Leveneur, at Gutenhowen, Neerwinden, the

Hoche.

Hoche. the heights of Vertrich, and at Blangen, the republican army repassed the Dyle, breaking down the bridges; and Hoche enabled it to effect a retreat, by disputing every inch of ground along with the rear-guard.

When Dumourier threw off the disguise at the camp of Maulde, arresting the deputies from the convention, General Leveueur entrusted to young Hoche the delicate charge of carrying the news to Paris. His conduct on this occasion was so highly approved of by the administration, that he was raised to the rank of adjutant-general, and chief of battalion; but he declined a higher rank than captain and aide-de-camp to his patron.

When the British troops and the Austrians besieged Dunkirk, Houchard, who was ordered to cover the place, threw in supplies under the command of Souham and Adjutant-general Houche, the latter of whom inspired all around him with enthusiasm; keeping up the spirits of the troops and harassing the enemy by frequent sallies, while the right wing and centre of the besieging army were attacked by Jourdan. Hoche constructed several advanced works before the place, and for six weeks together was never in a bed. The representatives with the army, as a reward for his activity, appointed him chief of brigade.

Having obtained this rank, he was sent into Austrian Flanders, where invariable success attended all his movements. And when only 24 years of age, he was appointed commander in chief of the army of the Moselle, which had remained for a long time inactive, and even experienced some disgrace under Houchard. Few scenes of action could be more inauspicious than that upon which Hoche was now about to enter. The Austrians and Prussians were about 100,000 strong, under the command of the first officers in Europe, which presented a formidable front from the Upper Palatinate to the Hundsruok: and almost every position might be deemed impregnable. The troops of General Hoche were nearly undisciplined, and the nature of their situation rendered them dispirited; but their leader first endeavoured to gain their confidence, which he conceived made a general invincible; he restored military discipline; investigated the characters and talents of his officers; and punished or rewarded as necessity required.

To inspire the inhabitants on the frontiers with courage was his next object, for which purpose he visited the different towns in his vicinity, frequented popular societies, and addressed them in person; so that he not only secured a high degree of confidence, but even procured volunteers, clothes, and provisions. Having received instructions from the committee of public safety to raise the siege of Bitche and Landau; he drew a number of troops from the different garrisons, and on the event of an attack on the quarter he had weakened, he gave orders to General Moreau to shut himself up in Thionville, which place he was charged to defend until death. He formed such a general plan of operations as gave the strongest evidence of his great military talents; for if the subordinate parts of it miscarried (which was actually the case), the grand object, the effecting a junction with Pichegru, who commanded the army on the Rhine, was still within his reach. By a sudden and formidable manœuvre, he so astonished the enemy, that they immediately quitted the Sarre, and

after experiencing a defeat, retired towards the heights of Blisecastel, with the loss of 700 men killed upon the field. The duke of Brunswick retreated towards Kayserlautern, at which place the whole of the Prussian columnus formed a junction. General Hoche was well aware that his great object would be attained, if he could vanquish the enemy at this place, and therefore he began to scale the mountains, and when he reached the plain on the top, he found them deeply entrenched. In defiance of this advantageous position, he determined to give them battle, and as soon as the signal gun was fired, he advanced from the ranks, and tossing his hat in the air, he exclaimed "Long live the republic!" The attack on his part was bold, and the defence of the enemy was obstinate; about 40,000 were engaged on each side, but the able manner in which the duke of Brunswick had fortified his position, gave him evidently the advantage. After fighting for two days, Hoche obtained little or no advantage. The ammunition of the Prussians being exhausted, he next day determined to carry their entrenchments at the point of the bayonet; but being informed that they had obtained a supply during the night, he found it necessary to retreat. But he soon after relieved Landau, and effected a junction with General Pichegru, being appointed commander in chief of both armies.

The victorious Hoche afterwards made himself master of Germersheim; Worms and Spirens opened their gates to receive him, and Fort Vauban was retaken. It was his determination to cross the Rhine at Strasburgh, or Offendorf, and venture into the heart of Germany with 25,000 men; to which movement Pichegru was unfriendly, and had the address to prevail with the representatives then present to refuse their sanction. Robespierre now regarded him with a jealous eye; all his plans were treated with unmerited indignity, and his arrest was resolved on. This, however, would have been a desperate attempt at the head of his victorious troops, and therefore he was offered the chief command of the army of Italy; but no sooner had he arrived at Nice than he was sent a prisoner to Paris, where he remained confined for many months, almost entirely forgotten. Another temporary revolution procured his liberty, and Carnot consented to his being again employed, although he was far from being his warm friend.

He was appointed to the command of the army destined to protect the coasts of Cherbourg, a situation which by no means agreed with his disposition; for he was often heard to exclaim "how much happier are they who fight against the Prussians!" His situation was indeed disagreeable, for it was Frenchmen fighting against Frenchmen, and he succeeded a number of generals who had been nearly all of them degraded. His keen discernment enabled him to observe that ignorance and superstition were at the bottom of the contest, which made him adopt a plan of procedure very different from those of his predecessors; and he made this singular assertion to the committee of public safety, that a "few proclamations would be productive of infinitely more effect than sixteen pounders." He checked the depredations of his own soldiers, restored the confidence of the peasantry, and so highly satisfied the government, that the command of the district of Brest was committed to him. So profligate and abandoned had been the conduct of his predecessors, that he could

Hoche. not procure a lodging at Rennes, which he had come to protect from the insurgents, although he offered an extravagant price for it. Soon, however, was he enabled to disarm their prejudices; for instead of hunting down the priests, he allowed the celebration of the mass, ordered the clergy to be protected, and took many of the confessors into pay. These were not like the plaud of so young a man; they would have done honour to one who had studied human nature much longer than he had been in existence.

We have said that he protected both the priests and the people, but he discovered no disposition to negotiate with the chiefs. But the government having positively ordered him to do so, he began a treaty with Cormartin and some others, from which he was decidedly of opinion that the chief leaders might be gained over by money, and commissions in the republican army. He was accustomed to say, "with two hundred thousand livres and ten part of epaulets, I could gain over a majority of these men; as for the rest, a cane will suffice." The chiefs imposed upon the representatives with the army, but the general was not so easily deceived. Clermont having been permitted to travel through the cantons in which he had some influence, ostensibly to put a period to hostilities, was arrested by orders of General Hoche, being taken in the act of issuing false assignats. Cormartin, another rebel chief, gave the money to the royalists which he had received from the republic, and recruited an army of Chouans in the name of Louis XVIII. Government now perceived the necessity of giving General Hoche a discretionary power, who in consequence thereof arrested Cormartin; and being apprehensive that it was the design of Devils to take possession of the arsenal of Cisay, he marched against that leader, putting him and 300 of his associates to the bayonet.

When the ill-fated expedition against Quiberon was undertaken, and an English flotilla with ten thousand emigrants made a descent, and took possession, without opposition, of Penthièvre, and the peninsula it commands, Hoche having received strong reinforcements, commenced offensive operations, and determined to carry Fort Penthièvre by assault. This was opposed by the engineers as by far too desperate an undertaking, who recommended a regular siege; but the general was not to be diverted from the steady execution of his purpose. Having divided his army into three columns, he marched during the night, though assailed by a dreadful tempest. The fort was discovered about the dawn of day, which poured upon them such a tremendous fire of grape shot, that two of the divisions began to retire; but a general cry of victory soon made them return. Three hundred emigrants were put to death.

His next great military project was an expedition against Guernsey and Jersey, which we are told, was rejected by the influence of Boissy d'Anglas, who was at that time a member of the committee of public safety. But having obtained the chief command of the army of the West, the whole charge of the war in La Vendée was committed to his management, to which he was resolved to put a glorious termination, presenting the deluded people with the olive branch in one hand, and the sword in the other. Having granted a pardon to all who had been deceived, he proposed to

Hoche. unite the armies of Clerburg, Brest, and the West, under the appellation of the army of the coasts of the Ocean, which by the influence of Barras, was instantly adopted. Having marched against Charette with a body of troops, that chief was seized and ordered to be executed. In passing through Sarthe, Maine, Loire, and Morbihan, with his moving columns, he gave no quarter to the chiefs; but when he beheld the ignorant peasantry in arms, and at his mercy, he used to exclaim, These unfortunate people are Frenchmen! He declared the principal towns to be no longer in a state of siege; abolished martial law, dissolved military tribunals; and, after succeeding in the accomplishment of his wishes in the space of eight weeks, he was honoured with the title of *Pacificator of La Vendée*.

The next object which attracted his whole attention was the conquest of England, a country with which he appears to have been little acquainted. His plan, however, was much approved of by the minister of marine (Truguet); but every thing was wanting for the accomplishment of an undertaking so very extraordinary; and the attempt was restricted to Ireland alone. For this purpose he set out for Brest, and procured the removal of Admiral Villaret-Joyeuse, because he was inimical to his favourite project. General Hoche superintended the dock-yards, hastened the public works, and prepared every thing connected with a great naval equipment. It was the declaration of Rear-admiral Bruix, who fell at Aboukir, that Hoche would become the best minister of marine that France ever beheld, if he had only a single year's experience. When every thing was in readiness for the proposed descent upon Ireland, General Hoche embarked on board the frigate *La Fraternité*, this being the first time he was ever at sea. In a gale of wind he was separated from his army, which consisted of 15,000 men; part of the fleet appeared off the coast of Ireland, and some ships entered Bantry Bay; but without their general they could undertake nothing; and therefore after holding a council of war, they determined to return. General Hoche arrived some time after, but learning that the fleet had given up the enterprise, he steered back to the French coast, weeping, it is said, when he got the last sight of Ireland.

It was believed by some, that General Hoche would be disgraced on account of the total failure of this expedition; but instead of any such attempt, he was chosen to the command of the army of the Sambre and Meuse, which at different periods had been commanded by Jourdan, Kleber, and Bernadotte. The troops had continued for some time inactive, and so shocking were the excesses they had been accustomed to commit, that the officer whom he succeeded called them a *horde of robbers*. These unfavourable circumstances, however, did not terrify young Hoche, who commenced his labours with the reformation of the officers: he then bettered the situation of the men; attended to the very minutiae of the service, and he cast an eagle's eye on the conduct of the commissaries. Being also entrusted with the administration of the conquered countries, he appointed a board of five members to redress all grievances which might be brought before it.

Having signified to the enemy that the armistice was at an end, he dispatched a courier to the directory to inform

Hoche ||
|| **Hodegos.**

inform them, "that he was now ready with a body of 86,000 men, to proceed towards the Danube, and force the enemy to make peace on such terms as might be advantageous to the republic." He accordingly began his march, crossed the Rhine without any difficulty, and occupied the heights of Neuwied. He then pursued the enemy to Dierdorf, which they were forced to abandon, while he encamped at Montabaur and Altenkirchen. The Austrians at this time lost 1000 men killed, and 8000 prisoners, with a vast quantity of baggage and ammunition. This victorious career was stopped by the news of an armistice concluded between Bonaparte in Italy and the emperor.

He once more turned his attention to the invasion of Ireland, to prepare for which he visited Paris, and afterwards went to Holland; but while he was marching a body of troops to Brest, the defeat of the Dutch fleet under Admiral De Winter completely frustrated his designs. But as the directory was at a loss for a general of character in the metropolis, Hoche was made choice of, afterwards appointed minister at war, and favoured with the unlimited confidence of Barras. But as it was suspected that Hoche was too young to hold that important office, the council of five hundred sent a message to the executive power to receive information upon this point, during which General Hoche resigned, and set off for Charleville, where he had stationed a body of troops for the purpose, it was believed, of marching to Paris. These orders being countermanded, he set off for his head quarters. Although the royalist party was gaining ground in the legislature, and the general's health rapidly on the decline, he determined to celebrate the memorable 10th of August with great pomp and magnificence. He dispatched two confidential officers, Cherin and Angereau, to assist in the revolution which took place in a few days after their arrival in Paris, while he himself was labouring under a mortal distemper. He refused to comply with the advice of his physicians; and when a messenger arrived with intelligence respecting the events of the 18th *Fructidor*, he rose from his bed with this exclamation, "the republic triumphs!"

Soon after this he was appointed to command the army on the Rhine, on which he repaired immediately to Strasburg. At this place his malady increased, and perceiving that his end was fast approaching, he prepared to meet it with undaunted fortitude. He died on the 26th of September 1797.

HOCUS POCUS, a cant expression with which the exhibitors of legerdemain tricks generally prefaced their feats. They are thought to be derived from that arch legerdemain trick of the Romish priests converting the sacramental bread into Deity; in which wonderful metamorphosis the words *hoc est corpus* made a conspicuous part of the ceremony, and which words may be considered as the probable root of our modern *hocus-pocus*.

HOD, a sort of tray for carrying mortar, in use among bricklayers.

HODEGOS, a term purely Greek, *οδῆγος*, signifying *guide*. The word is chiefly used as the title of a book composed by Anastasius the Sinate, towards the close of the fifth century; being a method of disputing against the heretics, particularly the Acephali.

Mr Toland has also published a dissertation under the
VOL. X. PAR. II.

same title. Its subject is the pillar of fire, &c. which went before the Israelites as a guide in the desert.

HODGE-PODGE. See **HOTCH-POT**.

HODMAN, a cant term formerly used for a young scholar admitted from Westminster-school to be student in Christ-church in Oxford.

HODY, HUMPHRY, a learned English divine, was born in 1659. At 21 years of age, he published his celebrated Dissertation against Aristeus's history of the 70 interpreters; which was received with great applause by all the learned, Isaac Vossius excepted, who could not bear to have his opinions opposed by such a youth. Twenty years after, he treated the subject more fully in a work entitled, *De Bibliorum textibus originalibus, versionibus Græcis, et Latina vulgata, libri IV.* In 1689, he wrote the *Prolegomena* to John Melala's Chronicle, printed at Oxford; and the year after was made chaplain to Dr Stillingfleet bishop of Worcester. The deprivation of the nonjuring bishops engaged him in a controversy with Mr Dodwell; which recommended him to Archbishop Tillotson, to whom, and his successor Dr Tension, he was domestic chaplain. In 1698 he was made regius professor of the Greek tongue at Oxford, and archdeacon of Oxford in 1704. On occasion of the controversy about the convocation, he, in 1701, published *A History of English councils and convocations, and of the clergy's sitting in parliament, &c.* He died in 1706, leaving in MS. *An Account of those learned Grecians who retired to Italy on the taking of Constantinople, &c.* which was published in 1742 by Dr Jebb.

HOË, or **How**, a husbandman's tool, made like a cooper's adz, to cut up weeds in gardens, fields, &c. This instrument is of great use, and ought to be much more employed than it is in hacking and clearing the several corners and patches of land in spare times of the year, which would be no small advantage to it.

Horse-Hoe, a large kind of hoe drawn by horses, and used to stir the intervals in the new husbandry, and clear the corn from weeds. See **AGRICULTURE**.

HOEING, in the new husbandry, is the breaking or dividing the soil by tillage while the corn or other plants are growing therein.—It differs from common tillage (which is always performed before the corn or plants are sown or planted) in the time of performing it; and it is much more beneficial to the crop than any other tillage. This sort of tillage is performed various ways, and by means of different instruments, as described under the article **AGRICULTURE**.

HOEI-TCHOU, the most southern city of the province of Kiang-nan in China, and one of the richest of the empire. The people are economical and temperate, but they are active and enterprising in trade; they boast of their tea, varnish, and engravings, which are indeed the most esteemed in China. It has dependent upon it six cities of the third class; the mountains which surround this canton contain gold, silver, and copper mines.

HOEMATOPUS, a genus of birds of the order of grallæ. See **ORNITHOLOGY Index**.

HOFFMAN, the name of several eminent physicians; of whom Maurice Hoffman, and John Maurice Hoffman his son, practised at Altorf. Maurice died in 1698, leaving behind him many works; and was

Hodegos
||
|| Hoffman.

Hoffman
Hog's
Dung.

succeeded by his son John Maurice, who wrote as well as his father, and died in 1727, highly esteemed by the faculty.—Frederic Hoffman, probably of the same family, was born at Magdeburg in 1660. The principal known circumstances of his life are, his journey into Holland and England, where he became intimately acquainted with Paul Herman and Robert Boyle, never taking any fees, being supported by his annual stipend; his curing the emperor Charles VI. and Frederic I. king of Prussia of inveterate diseases; to which may be added, his accurate knowledge of the nature and virtues of mineral waters. He survived his 80th year, and his works, which are in great esteem, were printed in six volumes folio at Geneva, in 1740.

HOFFMANISTS, in ecclesiastical history, denote those who espoused the sentiments of Daniel Hoffman, professor of the university of Helmstadt, who, from the year 1598, maintained, that philosophy was a mortal enemy to religion, and that what was true in philosophy was false in theology. These absurd and pernicious tenets occasioned a warm and extensive controversy: at length Hoffman was compelled by Julius duke of Brunswick to retract his invectives against philosophy, and to acknowledge, in the most open manner, the harmony and union of sound philosophy with true and genuine theology.

HOG. See SUS, MAMMALIA *Index*.

HOG, on board of a ship, is a sort of flat scrubbing broom, formed by inclosing a number of short twigs of birch or such wood between two pieces of plank fastened together, and cutting off the ends of the twigs; and serving to scrape the filth from a ship's bottom under water, particularly in the act of boot-topping. For this purpose they fit to this broom a long staff with two ropes; one of which is used to thrust the hog under the ship's bottom, and the other to guide and pull it up again close to the planks. This business is commonly performed in the ship's boat, which is confined as close as possible to the vessel's side during the operation, and shifted from one part of the side to another till the whole is completed.

Hog's Dung is by Mortimer reckoned one of the richest manures we are acquainted with, and the next in value to sheep's dung; and is found to be equal in virtue to twice the quantity of any other dung except this. The ancients seem to have been displeas'd with it on account of its breeding weeds; but this is only accusing it of being too rich; for any dung will do this when laid too thick. It is an excellent manure for pasture-grounds, and excels all other kinds of dung for trees. The farmers who use this dung for their lands, generally take care to save it, by well-paving the styes; and increase the quantity by throwing in bean-stalks, stubble, and many other things of a like nature: and, by good management of this kind, many farmers have procured 50 or 60 loads of excellent manure a-year out of a small stye. The very best way of using this dung is by mixing it with horse-dung; and for this reason it is best to have the stye near the stable, that the two cleansings may be mixed in one heap, and used together.

They have in many parts of Staffordshire a poor, light, shallow land, on which they sow a kind of white

pea: the land is neither able to bear this nor any thing else to advantage for their reaping: but when the pease are ripe, they turn in as many hogs as the quantity of pease will fatten, suffering them to live at large, and to remain there day and night: in consequence of this, the lands will produce good crops of hay for several years afterwards; or, if too poor for that, it will at worst raise grass enough to make it good pasture-ground.

Hog's Lard. See AXUNGIA, MATERIA MEDICA *Index*.

HOGARTH, WILLIAM, a truly great and original genius, is said by Dr Burn to have been the descendant of a family originally from Kirby Thore, in Westmoreland. His father, who had been a schoolmaster in the same county, went early to London, where he was employed as a corrector of the press; and appears to have been a man of some learning, a dictionary in Latin and English, which he composed for the use of schools, being still existing in MS. He married in London, and kept a school in Ship-Court, in the Old Bailey. Our hero was born in 1697 or 1698, in the parish of St Martin, Ludgate. The outset of his life, however, was unpromising. "He was bound," says Mr Walpole, "to a mean engraver of arms on plate." Hogarth probably chose this occupation, as it required some skill in drawing: to which his genius was particularly turned, and which he contrived assiduously to cultivate. His master, it since appears, was Mr Ellis Gamble, a silversmith of eminence, who resided in Cranburn-street, Leicester-fields. In this profession it is not unusual to bind apprentices to the single branch of engraving arms and cyphers on every species of metal; and in that particular department of the business young Hogarth was placed; "but, before his time was expired, he felt the impulse of genius, and that it directed him to painting." During his apprenticeship, he set out one Sunday, with two or three companions, on an excursion to Highgate. The weather being hot, they went into a public house, where they had not been long before a quarrel arose between some persons in the same room. One of the disputants struck the other on the head with a quart pot, and cut him very much. The blood running down the man's face, together with the agony of the wound, which had distorted his features into a most hideous grin, presented Hogarth, who showed himself thus early "apprised of the mode Nature had intended he should pursue," with too laughable a subject to be overlooked. He drew out his pencil, and produced on the spot one of the most ludicrous figures that ever was seen. What rendered this piece the more valuable was, that it exhibited an exact likeness of the man, with the portrait of his antagonist, and the figures in caricature of the principal persons gathered round him.

How long he continued in obscurity we cannot exactly learn; but the first piece in which he distinguished himself as a painter is supposed to have been a representation of Wanstead Assembly. The figures in it, we are told, were drawn from the life, and without any circumstances of burlesque. The faces were said to be extremely like, and the colouring rather better than in some of his late and more highly finished performances. From the date of the earliest plate that

Hog's
Dung
Hogarth.

can

Hogarth. can be ascertained to be the work of Hogarth, it may be presumed that he began business on his own account at least as early as 1720.

His first employment seems to have been the engraving of arms and shop bills. The next was to design and furnish plates for booksellers. Mr Bowles, at the Black Horse in Cornhill, was one of his earliest patrons, whose prices were very low. His next friend in that line was Mr Philip Overton, who paid him somewhat better for his labour and ingenuity.

There are still many family pictures by Hogarth existing, in the style of serious conversation-pieces. What the prices of his portraits were, Mr Nichols strove in vain to discover; but he suspects they were originally very low, as the people who are best acquainted with them choose to be silent on that subject.

It happened, in the early part of Hogarth's life, that a nobleman who was uncommonly ugly and deformed came to sit to him for his picture. It was executed with a skill that did honour to the artist's abilities; but the likeness was rigidly observed, without even the necessary attention to compliment or flattery. The peer, disgusted at this counterpart of his dear self, never once thought of paying for a reflector that would only insult him with his deformities. Some time was suffered to elapse before the artist applied for his money; but afterwards many applications were made by him (who had then no need of a banker) for payment without success. The painter, however, at last hit upon an expedient, which he knew must alarm the nobleman's pride, and by that means answer his purpose. It was couched in the following card: "Mr Hogarth's dutiful respects to Lord —; finding that he does not mean to have the picture which was drawn for him, is informed again of Mr H's necessity for the money; if, therefore his lordship does not send for it in three days, it will be disposed of, with the addition of a tail, and some other little appendages, to Mr Hare, the famous wild-beast man; Mr H. having given that gentleman a conditional promise of it for an exhibition-picture on his lordship's refusal." This intimation had the desired effect. The picture was sent home, and committed to the flames.

Mr Walpole has remarked, that if our artist "indulged his spirit of ridicule in personalities, it never proceeded beyond sketches and drawings;" and wonders "that he never, without intention, delivered the very features of any identical person." Mr Nichols assures us, from unquestionable authority, that almost all the personages who attended the levee of the Rake were undoubted portraits; and that in "Southwark Fair," and the "Modern Midnight Conversation," as many more were discoverable. While Hogarth was painting the "Rake's Progress," he had a summer residence at Isleworth; and never failed to question the company who came to see these pictures, if they knew for whom one or another figure was designed. When they guessed wrong, he set them right.

The duke of Leeds has an original scene in the "Beggar's Opera," painted by Hogarth. It is that in which Lucy and Polly are on their knees, before their respective fathers, to intercede for the life of the hero of the piece. All the figures are either known or supposed to be portraits. If we are not misinformed, the late Sir Thomas Robinson (perhaps better known

by the name of Long Sir Thomas) is standing in one of the side-boxes. Macheath, unlike his spruce representative on our present stage, is a slouching bully; and Polly appears happily disencumbered of such a hoop as the daughter of Peachum within our younger memories has worn. Mr Walpole has a picture of a scene in the same piece, where Macheath is going to execution. In this also the likenesses of Walker, and Miss Fenton, afterwards duchess of Bolton (the first and original Macheath and Polly) are preserved. In the year 1726, when the affair of Mary Tofts, the rabbit-breeder of Godalming, engaged the public attention, a few of our principal surgeons subscribed their guinea a-piece to Hogarth, for an engraving from a ludicrous sketch he had made on that very popular subject. This plate, among other portraits, contains that of St André, then anatomist to the royal household, and in high credit as a surgeon. In 1727, Hogarth agreed with Morris an upholsterer to furnish him with a design on canvas, representing the element of earth as a pattern for tapestry. The work not being performed to the satisfaction of Morris, he refused to pay for it; and our artist, by a suit at law, recovered the money.

In 1730, Mr Hogarth married the only daughter of Sir James Thornhill, by whom he had no child. This union, indeed, was a stolen one, and consequently without the approbation of Sir James, who, considering the youth of his daughter, then barely 18, and the slender finances of her husband, as yet an obscure artist, was not easily reconciled to the match. Soon after this period, however, he began his "Harlot's Progress" (the coffin in the last plate is inscribed Sept. 2. 1731); and was advised by Lady Thornhill to have some of the scenes of it placed in the way of his father-in-law. Accordingly, one morning early, Mrs Hogarth undertook to convey several of them into his dining-room. When he arose, he inquired from whence they came; and being told by whom they were introduced, he cried out, "Very well; the man who can furnish representations like these can also maintain a wife without a portion." He designed this remark as an excuse for keeping his purse-strings close; but, soon after, became both reconciled and generous to the young people. An allegorical ceiling by Sir James Thornhill is at the house of the late Mr Huggins, at Healdy Park, Hants. The subject of it is the story of Zephyrus and Flora; and the figure of a satyr and others were painted by Hogarth.

In 1732, Hogarth ventured to attack Mr Pope, in a plate called "The Man of Taste;" containing a view of the Gate of Burlington-house, with Pope white-washing it and bespattering the duke of Chandos's coach. This plate was intended as a satire on the translator of Homer, Mr Kent the architect, and the earl of Burlington. It was fortunate for Hogarth that he escaped the lash of the former. Either Hogarth's obscurity at that time was his protection, or the bard was too prudent to exasperate a painter who had already given such proof of his abilities for satire.

Soon after his marriage, Hogarth had summer lodgings at South Lambeth: and being intimate with Mr Tyres, contributed to the improvement of the Spring Gardens at Vauxhall, by the hint of embellishing them with paintings, some of which were the suggestions of

Hogarth.

Hogarth. his own truly comic pencil. For his assistance, Mr Tyres gratefully presented him with a gold ticket of admission for himself and his friends.

In 1733, his genius became conspicuously known. The third scene of his "Harlot's Progress" introduced him to the notice of the great. At a board of treasury which was held a day or two after the appearance of that print, a copy of it was shown by one of the lords, as containing, among other excellencies, a striking likeness of Sir John Gonson. It gave universal satisfaction: from the treasury each lord repaired to the print-shop for a copy of it, and Hogarth rose completely into fame.

The ingenious Abbé Du Bos has often complained that no history-painter of his time went through a series of actions, and thus, like an historian, painted the successive fortunes of an hero from the cradle to the grave. What Du Bos wished to see done, Hogarth performed. He launches out his young adventurer a simple girl upon the town, and conducts her through all the vicissitudes of wretchedness to a premature death. This was painting to the understanding and to the heart; none had ever before made the pencil subservient to the purposes of morality and instruction: a book like this is fitted to every soil and every observer; and he that runs may read. Nor was the success of Hogarth confined to his persons. One of his excellencies consisted in what may be termed the furniture of his pieces; for as, in sublime and historical representations, the fewer trivial circumstances are permitted to divide the spectator's attention from the principal figures, the greater is their force; so, in scenes copied from familiar life, a proper variety of little domestic images contributes to throw a degree of verisimilitude on the whole. "The Rake's levee-room," says Mr Walpole, "the nobleman's dining-room, the apartments of the husband and wife in Marriage à la Mode, the alderman's parlour, the bed-chamber, and many others, are the history of the manners of the age."

In 1745, Hogarth sold about 20 of his capital pictures by auction; and in the same year acquired additional reputation by the six prints of "Marriage à la Mode," which may be regarded as the ground-work of a novel called "The Marriage Act," by Dr Shebbeare, and of "The Clandestine Marriage."

Soon after the peace of Aix la Chapelle, he went over to France, and was taken into custody at Calais while he was drawing the gate of that town; a circumstance which he has recorded in his picture, entitled, "O the Roast Beef of Old England!" published March 26. 1749. He was actually carried before the governor as a spy, and after a very strict examination committed a prisoner to Gransire, his landlord, on his promising that Hogarth should not go out of his house till he was to embark for England.

In 1753, he appeared to the world in the character of an author, and published a quarto volume, entitled, "The Analysis of Beauty, written with a view of fixing the fluctuating ideas of taste." In this performance he shows, by a variety of examples, that a curve is the line of beauty, and that round swelling figures are most pleasing to the eye; and the truth of his opinion has been countenanced by subsequent writers on the subject. In this work, the leading idea of which

was hieroglyphically thrown out in 1745, he acknowledged his friends for assistance, and a third part of the *wording*. James Hoadley the physician, to about the third part, Chap. indisposition, declined the fri Mr Hogarth applied to his n it was impossible for two such alike vain and positive. He about a sheet, and they then to have continued such. Th the work, and superintendi lastly taken up by Dr Morel remainder of the book. The ner corrected by the Rever family of Hogarth rejoiced v "Analysis," was printed off he had with his coadjutors, it did not much harmonize hi was translated into Germa England, under the author's lation was printed in Lond new and correct edition was lication at Berlin, by Ch. tion of Mr Hogarth's satir the French; and an Italian at Leghorn in 1761.

Hogarth had one failing ple who attain wealth and liberal education.—He all of knowledge which he did blished his fame with litt ture, he either conceived it because it lay out of hi short, resembled those of sentence on the clerk of write and read. Till, in tist commenced author, a friends already mentioned Beauty," he did not see spelling was a necessary ventured to ridicule the to this particular, in a n whose play is refused w for debt. Previous to t speaking, one of our ar mation was the useless profession. In "Beer consigned by him to t bull "on Ancient Pa garth should have been ventured to condemn. not more ductile to f "Sigismunda," his fa manded a proof print, of our artist's hands. story of our artist wi more easy it is to dete lation respecting othe Hogarth being at din some other company, surgeon of St Bartho before, at Dick's coff

Hogarth. not rise. In *composition* we see little in him to admire. In many of his prints the deficiency is so great as plainly to imply a want of all principle; which makes us ready to believe, that when we do meet with a beautiful group, it is the effect of chance. In one of his minor works, the *Idle Prentice*, we seldom see a crowd more beautifully managed than in the last print. If the sheriff officers had not been placed in a line, and had been brought a little lower in the picture, so as to have formed a pyramid with the cart, the composition had been unexceptionable; and yet the first print of this work is such a striking instance of disagreeable composition, that it is amazing how an artist who had any idea of beautiful forms could suffer so unmasterly a performance to leave his hands. Of the *distribution of light* Hogarth had as little knowledge as of *composition*. In some of his pieces we see a good effect, as in the *Execution* just mentioned; in which, if the figures at the right and left corners had been *kept down* a little, the light would have been beautifully distributed on the fore-ground, and a fine secondary light spread over part of the crowd. But at the same time there is so obvious a deficiency in point of effect in most of his prints, that it is very evident he had no principles. Neither was Hogarth a master in *drawing*. Of the muscles and anatomy of the head and hands he had perfect knowledge; but his trunks are often badly moulded, and his limbs ill set on; yet his figures, upon the whole, are inspired with so much life and meaning, that the eye is kept in good-humour in spite of its inclination to find fault. The author of the *Analysis of Beauty*, it might be supposed, would have given us more instances of *grace* than we find in the works of Hogarth; which shows strongly that theory and practice are not always united. Many opportunities his subjects naturally afford of introducing graceful attitudes, and yet we have very few examples of them. With instances of picturesque grace his works abound. Of this *expression*, in which the force of his genius lay, we cannot speak in terms too high. In every mode of it he was truly excellent. The passions he thoroughly understood, and all the effects which they produce in every part of the human frame. He had the happy art also of conveying his ideas with the same precision with which he conceived them. He was excellent too in expressing any humorous oddity which we often see stamped upon the human face. All his heads are cast in the very mould of nature. Hence that endless variety which is displayed through his works; and hence it is that the difference arises between *his* heads and the affected caricatures of those masters who have sometimes amused themselves with patching together an assemblage of features from their own ideas. Such are Spaniolet's: which, though admirably executed, appear plainly to have no archetypes in nature. Hogarth's, on the other hand, are collections of natural curiosities. The *Oxford-heads*, the *Physicians arms*, and some of his other pieces, are expressly of this humorous kind. They are truly comic, though ill-natured effusions of mirth: more entertaining than Spaniolet's, as they are pure nature; but less innocent, as they contain ill-directed ridicule.—But the species of expression in which this master perhaps most excels, is that happy art of catching those peculiarities of art and gesture which the ridiculous part of every profession contract, and

which for that reason become characteristic of the whole. His counsellors, his undertakers, his lawyers, his usurers, are all conspicuous at sight. In a word, almost every profession may see in his works that particular species of affectation which they should most endeavour to avoid. The *execution* of this master is well suited to his subjects and manner of treating them. He etches with great spirit, and never gives one unnecessary stroke."

HOGSHEAD, in *Commerce*, a measure of capacity containing 63 gallons, = 16 gallons in Scotland.

HOGUE, a town and cape on the north-west point of Normandy in France; near which Admiral Rook burnt the French admiral's ship called the *Rising Sun*, with 12 more large men of war, the day after the victory obtained by Admiral Russel near Cherbourg in May 1692. W. Long. 2. 0. N. Lat. 49. 50.

HOIST, in sea-language, denotes the perpendicular height of a flag or ensign, as opposed to the fly, which signifies its breadth from the staff to the outer edge.

HOISTING signifies the operation of drawing up any body by the assistance of one or more tackles. Hoisting is never applied to the act of pulling up any body by the help of a single block, except in the exercise of extending the sails by drawing them upwards along the masts or stays, to which it is invariably applied.

HOKE-DAY, *Hock-Day*, or *Hock-Tuesday*, in our ancient customs (*die Martis, quem quindenam pascha vocant*), the second Tuesday after Easter week; a solemn festival celebrated for many ages in England in memory of the great slaughter of the Danes in the time of King Ethelred, they having been in that reign almost all destroyed in one day in different parts of the kingdom, and that principally by women. This is still kept up in some counties; and the women bear the principal sway in it, stopping all passengers with ropes and chains, and exacting some small matter from them to make merry with. This day was very remarkable in former times, insomuch as to be used on the same footing with Michaelmas for a general term or time of account. We find leases without date reserving so much rent payable *ad duos anni terminos, scil. ad le hoke-day, et ad festum sancti Michaelis*. In the account of Magdalen college, Oxford, there is yearly an allowance *pro mulieribus hockantibus* of some manors of theirs in Hampshire; where the men hock the women on Mondays and the women hock them on Tuesdays. The meaning of it is, that on that day the women in merriment stopped the way with ropes, and pulled passengers to them, desiring something to be laid out for pious uses.

Hock-Day Money, or *Hock-Tuesday Money*, a tribute anciently paid the landlord, for giving his tenants and bondmen leave to celebrate hock-day, or hoke-day, in memory of the expulsion of the domineering Danes.

HO-KIEN-FOU, a city of China, and one of the principal in the province of Pe-toheli. It has two cities of the second, and fifteen of the third class in its district, but is remarkable for nothing but the neatness of its streets.

HOLBEIN, HANS, a celebrated painter, born at Basil in Switzerland in 1498, learned the rudiments of his art from his father, who was a painter; but soon shewed his superior genius. In the town-house of

Hogarth
H
Holbein

Holbein. of Basil he painted our Saviour's Passion; and in the fish-market of the same city Death's Dance, and a Dance of Peasants, which were extremely admired; and Erasmus was so pleased with them, that he desired him to draw his picture, and was ever after his friend. He staid some years longer at Basil, till his necessities, occasioned by his own extravagance and an increasing family, made him comply with Erasmus's persuasions to go to England. In his journey he staid some days at Strasburg, where it is said he applied to a very great painter for work, who took him in, and ordered him to give a specimen of his skill. On which Holbein finished a piece with great care, and painted a fly on the most eminent part of it; after which he privately withdrew in the absence of his master, and pursued his journey, without saying any thing to any body. When the painter returned home, he was astonished at the beauty and elegance of the drawing; and especially at the fly, which he at first took for a real one, and endeavoured to remove it with his hand. He now sent all over the city for his journeyman; and after many inquiries, discovered that he had been thus deceived by the famous Holbein.—Holbein having in a manner begged his way to England, presented a letter of recommendation from Erasmus to Sir Thomas More, and also showed him Erasmus's picture. Sir Thomas, who was then lord chancellor, received him with all the joy imaginable, and kept him in his house between two and three years; in which time he drew Sir Thomas's picture, and those of many of his relations and friends. Holbein one day happening to mention a nobleman who had some years before invited him to England, Sir Thomas was very solicitous to know who it was. Holbein said that he had forgot his title, but remembered his face so well, that he believed he could draw his likeness; which he did so perfectly, that the nobleman, it is said, was immediately known by it. The chancellor having now adorned his apartments with the productions of this great painter, resolved to introduce him to Henry VIII. For this purpose he invited that prince to an entertainment; having, before he came, hung up all Holbein's pieces in the great hall, in the best order, and placed in the best light. The king, on his first entrance into this room, was so charmed with the sight, that he asked whether such an artist was now alive, and to be had for money? Upon this, Sir Thomas presented Holbein to his majesty, who immediately took him into his service, and brought him into great esteem with the nobility and gentry, by which means he drew a vast number of portraits. But while he was here, there happened an affair which might have proved fatal to him, had he not been protected by the king. On the report of this painter's character, a lord of the first quality came to see him when he was drawing a figure after the life. Holbein sent to desire his lordship to defer the honour of his visit to another day; which the nobleman taking for an affront, broke open the door, and very rudely went up stairs. Holbein hearing a noise, came out of his chamber; and meeting the lord at his door, fell into a violent passion, and pushed him backwards from the top of the stairs to the bottom. However, immediately reflecting on what he had done, he escaped from the tumult he had raised, and made the best of his way to the king. The nobleman, much hurt, though not so

much as he pretended, was there soon after him; and upon opening his grievance, the king ordered Holbein to ask his pardon. But this only irritated the nobleman the more, who would not be satisfied with less than his life; upon which the king sternly replied, "My lord, you have not now to do with Holbein but with me; whatever punishment you may contrive by way of revenge against him, shall certainly be inflicted on yourself. Remember, pray, my lord, that I can whenever I please make seven lords of seven ploughmen, but I cannot make one Holbein of even seven lords." Holbein died of the plague at his lodgings at Whitehall in 1554. "It is amazing (says De Piles, that a man born in Switzerland, and who had never been in Italy, should have so good a *gusto*, and so fine a genius for painting." He painted alike in every manner; in fresco, in water-colours, in oil, and in miniature. His genius was sufficiently shown in the historical style, by two celebrated compositions which he painted in the hall of the Stillyard company. He was also eminent for a rich vein of invention, which he showed in a multitude of designs which he drew for engravers, statuaries, jewellers, &c. and he had this singularity, that he painted with his left hand.

HOLCUS, INDIAN MILLET or CORN, a genus of plants belonging to the polygamia class, and in the natural method ranking under the 4th order, *Gramina*. See *BOTANY Index*.

HOLD, the whole interior cavity or belly of a ship, or all that part of her inside which is comprehended between the floor and the lower-deck throughout her whole length.—This capacious apartment usually contains the ballast, provisions, and stores of a ship of war, and the principal part of the cargo in a merchantman. The disposition of these articles with regard to each other, naturally falls under consideration in the article *STOWAGE*; it suffices in this place to say, that the places where the ballast, water, provisions, and liquors are stowed, are known by the general name of the *hold*. The several store-rooms are separated from each other by *bulk-heads*, and are denominated according to the articles which they contain, the *sail-room*, the *bread-room*, the *fish-room*, the *spirit-room*, &c.

HOLDER, WILLIAM, D. D. an English divine, was born in Nottinghamshire, educated in Pembroke-hall, Cambridge, and in 1642 became rector of Blechingdon of Oxford. In 1660 he proceeded D. D. was afterwards canon of Ely, fellow of the Royal Society, canon of St Paul's, sub-dean of the royal chapel, and sub-almoner to his majesty. Dr Holder was a very accomplished scholar, and greatly distinguished himself, by making a young gentleman of rank who was born deaf and dumb, to speak. This gentleman's name was Alexander Popham, son of Colonel Edward Popham, who was some time an admiral in the service of the long parliament. The cure was performed by him in his house at Blechingdon in 1659; but Popham losing what he had been taught by Holder after he was called home to his friends, was sent to Dr Wallis, who brought him to his speech again. Holder published a book, entitled "The Elements of Speech; an essay of enquiry into the natural Production of Letters; with an appendix concerning persons that are deaf and dumb, 1669," 8vo. In the appendix he relates how

Holbein
||
Holder.

Holder
||
Holiness.

soon, and by what methods, he brought Popham to speak. In 1678, he published in 4to "a Supplement to the Philosophical Transactions of July 1670, with some reflections on Dr Wallis's letter there inserted." This was written to claim the glory of having taught Popham to speak, which Wallis in the said letter had claimed to himself; upon which the Doctor soon after published "a Defence of the Royal Society, and the Philosophical Transactions, particularly those of July 1670, in answer to the Cavils of Dr William Holder, 1678," 4to. Holder was skilled in the theory and practice of music, and wrote "a Treatise of the natural Grounds and Principles of Harmony, 1694," 8vo. He wrote also "a Discourse concerning Time, with Application of the natural Day, lunar Month, and solar Year, &c. 1694," 8vo. He died at Amen Corner in London, January 24. 1696-7, and was buried in St Paul's.

HOLDERNESS, a district of the east riding of Yorkshire, having the German sea on the east, and the Humber on the south. This district is remarkable for its rich soil and a large breed of horned cattle and horses. It had the title of an earldom, now extinct.

HOLDSWORTH, EDWARD, a very polite and elegant scholar, was born about 1688, and educated at Winchester school. He was thence elected demy of Magdalen college, Oxford, in July 1705; took the degree of M. A. in April 1711; became a college-tutor, and had many pupils. In 1715, when he was to be chosen into a fellowship, he resigned his demyship and left the college, because unwilling to swear allegiance to the new government. The remainder of his life was spent in travelling with young noblemen and gentlemen as tutor; in 1741 and 1744 he was at Rome in this capacity. He died of a fever at Lord Digby's house at Coleshill in Warwickshire, December 30. 1747. He was the author of the "Muscipula," a poem, esteemed a master-piece in its kind, and of which there is a good English translation by Dr John Hoadley, in vol. v. of Dodsley's Miscellanies. He was the author also of a dissertation, entitled "Pharsalia and Philippi; or the two Philippi in Virgil's Georgics attempted to be explained and reconciled to History, 1741," 4to: and of Remarks and Dissertations on Virgil; with some other classical Observations, published with several notes and additional remarks by Mr Spence, 1768," 4to. Mr Spence speaks of him in Polymetis, as one who understood Virgil in a more masterly manner than any person he ever knew.

HOLORACEÆ, (from *holus*, "pot-herbs"); the name of the 12th order in Linnæus's fragments of a natural method, consisting of plants which are used for the table, and enter into the economy of domestic affairs. See *BOTANY Index*.

HOLIBUT. See *PLEURONECTES, ICHTHYOLOGY Index*.

HOLINESS, or **SANCTITY**; a quality which constitutes or denominates a person or thing *holy*; i. e. pure, or exempt from sin. The word is also used in respect of persons and things that are sacred, i. e. set apart to the service of God, and the uses of religion.

HOLINESS, is also a title of quality attributed to the pope; as that of *majesty* is to kings. Even kings, when writing to the pope, address him under the venerable

appellation of *Your Holiness*, or *Holy Father*; in Latin, *Sanctissime* or *Beatissime Pater*. Anciently the same title was given to all bishops. The Greek emperors also were addressed under the title of *Holiness*, in regard of their being anointed with holy oil at their coronation. Du Cange adds, that some of the kings of England have had the same attribute; and that the orientals have frequently refused it to the pope.

HOLINGSBED, RALPH, or **RAPHAEL**, was one of the humble but useful class of historians called *Chronologers*. He was educated at Cambridge, according to Bishop Tanner, and became A. M. in the year 1544. The nature and extent of his education, as well as his profession, are involved in uncertainty. It seems probable, however, that he was steward to Thomas Burdett, Esq. of Bomcote in Warwickshire, where he died about the year 1580. He has given name to a compilation of Chronicles of English history from the earliest times, the first edition of which was published at London in 1577, in two volumes folio, and the second edition in three volumes, was printed about seven years after his death, brought down to 1586. This work, according to the testimony of Holingsbed himself, was begun by the advice of Reginald Wolfe, printer to Queen Elizabeth. Part of it was compiled by himself, but he received considerable assistance from William Harrison, John Hooker, Abraham Fleming, Francis Thynne, and some others. It was continued by John Stowe after the death of Holingsbed. Some parts of the first edition were altered in the second and third, because they gave offence to Queen Elizabeth and the ministry, who laid many restrictions on the liberty of the press. The first edition of consequence is both scarce and valuable; but the suppressed sheets were afterwards printed by themselves. The chronicles of Holingsbed, although considered as both tedious and vulgar, contain many important facts, which tend to illustrate the customs and manners of remote periods.

HOLLAND, PHILEMOND, M. D. commonly called the translator general of his age, was educated in the university of Cambridge. He was for many years a schoolmaster at Coventry, where he also practised physic. He translated Livy, Pliny's Natural History, Plutarch's Morals, Suetonius, Ammianus Marcellianus, Xenophon's Cyropædia, and Camden's Britannia, into English; and the geographical part of Speed's Theatre of Great Britain into Latin. The Britannia, to which he made many useful additions, was the most valuable of his works. It is surprising that a man of two professions could find time to translate so much; but it appears from the date of the Cyropædia, that he continued to translate till he was 80 years of age. He died in 1637, aged 85. He made the following epigram upon writing a large folio with a single pen:

With one sole pen I wrote this book,
Made of a grey goose quill;
A pen it was when it I took,
And a pen I leave it still.

HOLLAND, the largest of the seven United Provinces, divided into South and North Holland, the latter of which is also called *West Friesland*, is bounded on the west by the German ocean, or North sea; to the

Holiness
||
Holland.

Holland. the east by the Zuyder-see, the province of Utrecht, and part of Guelderland; to the south by Dutch Brabant and Zealand; and to the north by the Zuyder-see. Its greatest extent from north to south including the island of Texel, is about 90 English miles; but from east to west its extent varies from 40 to 25. To defend it against the sea, dykes have been erected at an immense expence, and innumerable canals cut to drain it, as being naturally very low and marshy. Some parts of the province are very fruitful in corn; but the greater part consists of rich pastures, wherein are kept large herds of kine, which supply them with incredible quantities of butter and cheese. Of the latter, that of Edam, in North Holland, is highly esteemed. The many rivers and canals that intersect the province are of great advantage to its commerce, but contribute to render the air foggy and unwholesome. There is a communication by water betwixt almost every town and village. Towards the middle also of the province are great numbers of turf-pits. The number of the inhabitants in 1817 was 748,000. In point of cleanliness no country surpasses, and few come up to it, especially in North Holland, and that even in the villages. From the counts of Holland this province devolved, in 1436, to the dukes of Burgundy, and from them to the house of Austria, along with the other provinces. By the ancient constitution of the country the states of Holland and West Friesland were composed of the nobility and deputies of the towns; of the latter there were 18 that sent deputies to the assembly of the states, which was held at the Hague. The grand pensionary was a person of great dignity and weight in this assembly, and his office required extraordinary abilities. There were also two councils composed of deputies, one for South and another for North Holland, who had the cognizance of the revenue and military affairs. The whole province sent one deputy from among the noblesse to the states-general, who took precedence of all others, together with three or four more. There were two supreme courts of judicature for Holland and Zealand; viz. the great council of Holland and Zealand, and the hof or court of Holland. To these appeals lay from the towns; but the causes of noblemen came before them in the first instance. With respect to the ecclesiastical government, there is a synod held annually both in South and North Holland, of which the former contains eleven classes, and the latter six; and the ministers of both together amount to 331. In the whole province are 37 towns, eight boroughs, and 400 villages.

Soon after the commencement of the French revolution, this ill-fated country became the theatre of war, the old government was subverted, and the stadtholder having fled to England for safety, the republican rulers of France imposed a political constitution upon it according to their pleasure. The infatuated people of Holland received their conquerors with apparent, perhaps with real satisfaction at first; but experience fatally taught them the pernicious nature of the change. As the government of France changed from directorial to consular, and from consular to imperial, that of Holland also received various modifications, till at last it was converted into a monarchy under one of Bonaparte's brothers, who afterwards withdrew from his kingdom, and then Holland was annex-

ed to France. In this state it remained, till the successes of the allies in 1813 restored the prince of Orange. For a copious detail of the political vicissitudes which Holland has experienced in consequence of the French revolution, see the article *FRANCK*; and for the history, see *UNITED PROVINCES*.

HOLLAND, one of the divisions of Lincolnshire in England. It so much resembles the province of that name upon the continent, in most respects, being low and marshy, with the sea on one side, and canals running through it, that it must either have had its name from thence or on the same account. On the east it has what the ancient geographers call *Estuarium Mætuariis*, now the Washes, which are overflowed at high water, and part of Cambridgeshire on the south. The lower part of it is full of bogs and marshes, and has huge banks to defend it against the sea and land floods. The ground is so soft that horses are worked unshod; and it produces plenty of grass, but little corn. The whole tract seems to have been gained from the sea; and is divided into Upper and Lower, the latter of which was impassable; but since the fens have been drained, the lands are grown more solid, and the inhabitants sow cole-seed upon them to their great profit. Though there are no stones to be found in or upon the ground, yet most of the churches are of stone. They have no fresh water but from the clouds, which is preserved in pits: but if these are deep, it soon turns brackish; and if they are shallow, they soon become dry.

New HOLLAND, the largest island in the world, reaching from 10 to 40° S. Lat. and between 114 and 153 of E. Long. from London. It received its name from having been chiefly explored by Dutch navigators. The land first discovered in those parts was called *Eendragt* (Concord) *Land*, from the name of the ship on board which the discovery was made in 1616; 24° and 25° south. In 1618, another part of this coast, nearly in 15° south, was discovered by Zeachen, who gave it the name of *Arnheim* and *Diemen*; though a different part from what afterwards received the name of Diemen's Land from Tasman, which was supposed to be the southern extremity, in latitude 43°. This is now found to be an island separated from New Holland by Bass's Straits. See *DIEMAN'S Land*.

In 1619, Jan Van Edels gave his name to a southern part of New Holland. Another part situated between 30 and 33° received the name of *Leuwen*. Peter Van Nuitz gave his name, in 1627, to a coast which communicates to Leuwen's Land towards the westward; and a part of the western coast, near the tropic of Capricorn, bore the name of *De Wit's*. In 1628, Peter Carpenter, a Dutchman, discovered the great gulf of Carpentaria, between 10 and 20° south. In 1687, Dampier, an Englishman, sailed from Timor, and coasted the western parts of New Holland. In 1699, he left England, with a design to explore this country, as the Dutch suppressed whatever discoveries had been made by them. He sailed along the western coast of it, from 28 to 15°. He saw the land of Eendragt and of De Wit. He then returned to Timor, from whence he went out again; examined the isles of Papua; coasted New Guinea; discovered the passage that bears his name; called a great island which forms this passage or strait on the east side, *New Britain*; and

Holland.
New Hol-
land.

New Hol-
land.

sailed back to Timor along New Guinea, This is the same Dampier who between 1683 and 1691, sailed round the world by changing his ships. Notwithstanding the attempts of all these navigators, however, the eastern part of this vast tract was totally unknown till Captain Cook made his voyages; and by fully exploring that part of the coast, gave his country an undoubted title to the possession of it; which accordingly has since been taken possession of under the name of *New South Wales*.

Whether
the name
of *continent*
belongs to
New Hol-
land.

Some have disputed whether the title of *island* can be properly applied to a country of such vast extent, or whether it ought not rather to be denominated a *continent*; while others have replied, that though the word *island*, and others similar to it, do indeed signify a tract of land surrounded by sea, yet in the usual acceptation it means only a land of moderate extent surrounded in this manner. Were it otherwise, we might call the whole world an island, as it is every where surrounded by the sea; and in fact, Dionysius Periegetes applies this term to it, with the addition of the word *immense*, to distinguish it from other islands. The best rule, according to Mr Stockdale, for determining when a country ought to lose the name of *island* and begin to be called a *continent*, is when it begins to lose the advantages of an insular situation. The first and principal of these, is the being capable of an union under one government, and thence deriving a security from all external attacks excepting those by sea; but in countries of great extent, this is not only difficult, but impossible. If we consider, therefore, New Holland as extending about a thousand miles every way, we shall find that its claim to be called a continent is undoubted; its length from east to west being about 2400 English miles, and 2300 from north to south.

Captain
Cook's ac-
count of
the coun-
try.

This coast was first explored by Captain Cook in the year 1770; but his stay was too short to examine the nature of the country with the accuracy which he

would otherwise have done had he continued longer in it. In general, it was found rather barren than otherwise. Many brooks and springs were found along the eastern coast, but no river of any consequence. They found only two kinds of trees useful as timber, the pine, and another which produces a sort of gum. They found three kinds of palm trees; but few esculent plants, though there are abundance of such as might gratify the curiosity of the botanist. A great variety of birds were met with, which have since been particularly described; but the number of quadrupeds bears but a very small proportion to that of the other animals. The most remarkable insects seen at this time were the green ants (A), who build their nests upon trees in a very singular manner.

New Hol-
land.

This country has now become an object of more consequence than formerly, by reason of the establishment of a British colony in it; where the criminals condemned to be transported are sent to pass their time of servitude. Before this plan was resolved on by government, another had been discussed, viz. that of employing these criminals in workhouses; and Judge Blackstone, with Mr Eden and Mr Howard, had considered of the best method of putting it in execution; but though this plan had been approved by parliament as early as 1779, some difficulties always occurred, which prevented its going forward; and at length on the 6th of December 1786, orders were issued by his majesty in council for making a settlement on New Holland, establishing a court of judicature in the colony, and other regulations necessary on the occasion. The whole received the complete sanction of legislature in the beginning of the year 1787. The squadron appointed for putting the design in execution began to assemble at the Mother Bank, the place of rendezvous, in the Isle of Wight, on the 16th of March 1787. It consisted of the Sirius frigate Captain John Hunter, the Supply armed tender Lieutenant

3
Settlement
of a British
colony in
New Hol-
land.

(A) These little animals form their habitations, by bending down the leaves of trees, and gluing the ends of them together, so as to form a purse. Though these leaves are as broad as a man's hand, they perform this feat by main strength, thousands of them being employed in holding down the leaves, while multitudes of others apply the glutinous matter. Captain Cook's people ascertained themselves that this was the case, by sometimes disturbing them at their work; in which case the leaf always sprung up with an elasticity, which they could not have supposed that such minute insects were capable of overcoming. For this curiosity, however, they smarted pretty severely; for thousands of these little enemies instantly threw themselves upon the aggressors, and revenged themselves by their bites or stings for the interruption they had met with. These were little less painful at first than the sting of a bee; but the pain did not last above a minute. Another species of ants burrow themselves in the root of a plant which grows on the bark of trees like the mistletoe, and which is commonly as big as a large turnip. When this is cut, it appears intersected with innumerable winding passages all filled with these animals; notwithstanding which, the vegetation of the plant suffers no injury. These do not give pain by their stings, but produce an intolerable itching by crawling about on the skin. They are about the size of the small red ant in this country. Another sort, which do not molest in any manner, resemble the white ant of the East Indies. They construct nests three or four times as big as a man's head on the branches of trees; the outsides being composed of some vegetable matter along with a glutinous substance. On breaking the outer crusts of these hives, innumerable cells appear swarming with inhabitants, in a great variety of winding directions, all communicating with each other, and with several other nests upon the same tree. They have also another house built on the ground, generally at the root of a tree; formed like an irregular sided cone; sometimes more than six feet high, and nearly as much in diameter. The outside of these is well-tempered clay about two inches thick: and within are the cells, which have no opening outward. One of these is their summer and the other their winter dwelling, communicating with each other by a large avenue leading to the ground, and by a subterraneous passage. The ground structures are proof against wet, which those on the branches are not.

New Hol-
land.New Hol-
land.

nant H. L. Ball; three store-ships, the Golden-grove, Fishburn, and Borrowdale, for carrying provisions and stores for two years; and lastly, six transports, the Scarborough and Lady Penryn from Portsmouth, the Friendship and Charlotte from Plymouth, and the Prince of Wales and Alexander from Woolwich. These were to carry the convicts, with a detachment of marines in each proportioned to the nature of the service; the largest where resistance was most expected, viz. in those which carried the greatest number of male convicts. On the arrival of Governor Phillip at the station, he hoisted his flag on board the Sirius as commodore of the squadron; and the embarkation being completed, he gave the signal to weigh anchor on the 13th of May at day-break. The number of convicts was 778, of whom 558 were men. They touched at the island of Teneriffe on the 3d of June, without meeting with any bad accident. Here they staid a week, in order to procure such refreshments as were necessary for preventing the disorders mostly to be dreaded in such a long and perilous voyage. In this they succeeded to their wish; and were about to depart on the 9th of June, when it was discovered that one of the convicts had made his escape, having found means to cut away a boat and make off with it. He offered himself as a sailor aboard a Dutch vessel at that time in the harbour, but was refused; on which he attempted to conceal himself in a cove. In this he would probably have succeeded, had it not been for the boat, which he could not conceal; so that he was soon discovered and brought back to the ship, where, however, he obtained his pardon from the governor.

On the 10th of June the fleet set sail from Santa Cruz in the island of Teneriffe, and on the 18th came in sight of the Cape Verd islands, where they steered for St Jago: but the want of a favourable wind and other circumstances prevented their getting in; so that as Governor Phillip did not choose to waste time, they did not touch land till they came to Rio Janeiro on the coast of Brazil. It may seem surprising, that a voyage to the eastward, which of itself may be accounted of sufficient length, should thus be wilfully made so much longer, by sailing twice across the Atlantic. The calms, however, so frequent on the coast of Africa, seem of themselves to be a sufficient inducement for navigators to preserve a westerly course; and even the islands at which it is so necessary to touch, are not far distant from the American coast. The returning tracks of Captain Cook's three voyages are all within a little space of the 45th degree of west longitude, which is even 10 degrees farther west than Cape St Roque; and that course appears to have been taken voluntarily, without any extraordinary inducement.

During the time of their stay at Santa Cruz the weather had been very moderate; the barometer about 30 inches, and the thermometer never above 72; as they approached the Cape Verd islands it rose to 82, and did not exceed 82° 51' all the way from thence to Rio Janeiro. Here they met with a very favourable reception, contrary to that which Captain Cook experienced on a similar occasion. Provisions were so cheap, that though the allowance of meat was fixed by the governor at 20 ounces per day, the men were victualled completely at 3½d. each, including rice, vegetables, and every other necessary. Wine was not at this time to

be had except at an advanced price: but rum was laid in, and such seeds and plants procured as were thought most likely to flourish in New South Wales; particularly coffee, indigo, cotton, and the cochineal fig. An hundred sacks of cassada were likewise purchased as a substitute for bread, if it should happen to be scarce. By the kindness of the viceroy also, some deficiencies in the military stores were made up from the royal arsenal, and every assistance given which the place could afford. They arrived here on the 5th of August 1787, and set sail on the 4th of September, receiving as the last compliment from the governor a salute of 21 guns.

From Rio Janeiro the fleet had a fine run to Table Bay, in the southern extremity of Africa, which they accomplished in 39 days: where they took in the refreshments meant to supply them during the remainder of the voyage. Here they arrived on the 13th of October; and having supplied themselves with a great number of live stock, they set sail on the 12th of November, but were long impeded by contrary winds from the south-east. On the 25th they were only 80 leagues distant from the Cape, when Governor Phillip left the Sirius and went aboard the Supply tender; in hopes, by leaving the convoy, to gain sufficient time for examining the country round Botany Bay, that the most proper situation for the new colony might be chosen before the transports should arrive. They now met with favourable winds, blowing generally in very strong gales from the north-west, west, and south-west. The wind shifted only once to the east, but did not continue in that direction above a few hours. On the 3d of Ja-⁴ They ar-
nuary 1788 the Supply came within sight of New South-^{rive at}
Wales; but the winds then became variable, and ^{New Hol-}
a current, which at times set very strongly to the ^{land.}
southward, impeded her course so much, that it was not till the 18th of the month that she arrived at Botany Bay.

Governor Phillip no sooner landed than he had an ⁶ interview opportunity of conversing with the natives, who were with the natives. As it was the intention of this gentleman to conciliate if possible their friendship, he used every method at this first interview to inspire them with a favourable idea of the Europeans. For this purpose he presented them with beads and other trifling ornaments, which they seemed pleased to wear, though Captain Cook found them very indifferent about any kind of finery he could furnish them with. They seemed, according to the account of that celebrated navigator, to be so attached to their own ornaments, that they made no account of any thing else. They received indeed such things as were given them, but made no offer to return any thing in exchange; nor could they be made to comprehend that any thing of the kind was wanted. Many of the presents which they had received were afterwards found thrown away in the woods.

Governor Phillip having parted with his new ac-⁶ Inconveni-
quaintance in a friendly manner, next set about an ex-^{any of Bo-}
amination of the country about Botany Bay, which had ^{tany Bay}
been strongly recommended by Captain Cook as the ^{for a settle-}
most eligible place for a settlement. He found, how-^{ment.}
ever, that the bay itself was very inconvenient for ship-
ping; being exposed to the easterly winds, and so shel-
lop that ships even of a moderate burden could not

New Hol-
land.

get far enough within land to be sheltered from the fury of the ocean. Neither did the land about any part of this bay appear an eligible situation for a colony; being in some places entirely swampy, in others quite destitute of water. Point Sutherland seemed to afford the situation most free from objections, but the ships could not approach it; and even here the ground seemed to be universally damp and spongy: so that, on the whole, finding no place within the compass of the bay proper for the new settlement, they found themselves obliged to remove somewhere else.

The rest of the fleet arrived in two days after the Supply; and that no time might be lost, Governor Phillip ordered the ground about Point Sutherland to be cleared, and preparations to be made for landing, while he went with several officers in three boats to examine Port Jackson, which was only three leagues distant. Here they had the satisfaction to find one of the finest harbours in the world, where 1000 sail of the line might ride in perfect safety. On examining the different coves, one was preferred which had a fine run of spring water, and where ships could anchor so close to the shore, that at a very small expence quays might be constructed for loading and unloading the largest vessels. This was named by the governor *Sydney Cove*, in honour of Lord Sydney, and the country around it destined for the place of settlement. It is about half a mile long, and a quarter of a mile broad at the entrance. On the governor's return to Botany Bay, the reports made to him concerning the adjacent country were so exceedingly unfavourable, that orders were immediately given for the removal of the fleet to Port Jackson. On the morning of the 25th, therefore, the governor sailed from Botany Bay, and was soon followed by the whole fleet. In the mean time, they were surprised by the appearance of two other European vessels, which had been first sent off Botany Bay on the 24th. These were found to be two French ships, named the *Astrolabe* and *Boussole*, which had left France on a voyage of discovery under the command of M. la Peyrouse, in the year 1785. They had touched at the island of Santa Catharina on the coast of Brazil, and from thence gone by the extremity of South America into the Pacific ocean, where they had run along by the coasts of Chili and California; after which they had visited Easter Island, Nootka Sound, Cook's river, Kamtschatka, Manilla, the isles des Navigateurs, and the Sandwich and Friendly Isles. They had also attempted to land on Norfolk Island, but found it impossible on account of the surf. During the whole voyage none were lost by sickness; but two boats crews had unfortunately perished in a surf on the north-west coast of America; and at Masuna, one of the isles des Navigateurs, M. L'Angle, captain of the *Astrolabe*, with 12 of his people, officers and men, were murdered by the savages. This was the more surprising, as there had been an uninterrupted friendship with them from the time the French touched at the island, till that unfortunate moment. M. L'Angle had gone ashore with two long boats for the purpose of filling some water-casks. His party amounted to forty men; and the natives, from whom the French had already received abundance of refreshments, did not show any signs of a hostile disposition: But from whatever motive their resentment was excited, the men had no

sooner begun to get out the boats, than the savages made a most furious and unexpected assault with stones. In this encounter M. L'Angle himself, with the people above mentioned, fell a sacrifice to the treachery of these barbarians. The remainder of the party escaped with great difficulty; the ships having at that time passed a point of land which intercepted their view of the affray.

The convicts and others destined to remain in New South Wales being landed, no time was lost in beginning to clear ground for an encampment, store-houses, &c. The work, however, went on but slowly, partly owing to the natural difficulties they had to encounter; and partly to the habitual indolence of the convicts, which indeed was naturally to be expected considering their former way of life. Nevertheless, by the end of the first week of February, the plan of an encampment was formed, the places were marked out for different purposes, so that the colony already began to assume some appearance of order and regularity. The materials and frame-work of a slight temporary habitation for the governor had been brought out from England ready formed, which were landed and put together with as much expedition as circumstances would allow. Hospital tents were also erected; and the sickness which soon took place showed the propriety of so doing. In the passage from the Cape there had been but little sickness, and few of the convicts had died; but a little time after they landed a dysentery began to prevail, which proved fatal in several instances, and the scurvy began to rage with great violence, so that the hospital-tents were soon filled with patients. The disorder proved the more virulent as fresh provisions could but rarely be obtained; nor were esculent vegetables often obtained in such plenty as could produce any material alleviation of the complaint: the only remedy for the dysentery was found to be a kind of red gum, produced in plenty by the trees growing upon this coast. The yellow gum has the same properties, though in an inferior degree.

In the beginning of February, a most violent storm of thunder and lightning destroyed five of the sheep which had a shed erected for them under a tree, which proved a prelude to other misfortunes among the cattle. The encampment, however, was carried on with great alacrity; the foundations of the store-houses were laid, and every thing began to wear a promising appearance. On the 7th of the month a regular form of government was established in the colony, with all the solemnity which could possibly be given: the governor made a proper speech to the convicts, reminding them of the situation in which they stood; and that now, if they continued their former practices, it was impossible they could hope for mercy if detected; neither could they expect to escape detection in so small a society. Offenders, therefore, he said, would certainly be punished with the utmost rigour; though such as behaved themselves in a proper manner, might always depend upon encouragement. He particularly noticed the illegal intercourse betwixt the sexes, as a practice which encouraged profligacy in every respect; for which reason he recommended marriage: and this exhortation seemed not to be altogether in vain, as 14 marriages were celebrated that very week in consequence.

Heavy rains took place during the remainder of this month,

7
A settle-
ment form-
ed at Port-
Jackson.

8
Visited by
two French
ships.

9
Regular
form of
govern-
ment esta-
blished.

⁹ New Hol-
land. month, which showed the necessity of going on with the work as soon as possible. The want of carpenters, however, prevented this from being done so expeditiously as could have been wished. Only 16 of these could be hired from all the ships; and no more than 12 of the convicts were of this profession, of whom several were sick; so that the party were by far too few for the work they had to perform. A hundred convicts were added as labourers; but with every effort it was found impossible to complete either the barracks or the huts for the officers so soon as could be wished. On the 14th of February a small party was sent out to settle on Norfolk Island, who have since established a colony there which promises to be of considerable utility*. It was soon found, however, absolutely necessary to make examples of some of the convicts at Port Jackson. Towards the end of February it was found necessary to convene a criminal court, in which six of the convicts received sentence of death. One who was the head of the gang was executed the same day: one of the rest was pardoned; the other four were reprieved, and afterwards exiled to a small island within the bay, where they were kept on bread and water. They had frequently robbed both the stores and other convicts. The fellow who was executed, and two others, had been detected in stealing the very day on which they received a week's provision; and at the same time that their allowance was the same as that of the soldiers, spirituous liquors only excepted.

¹⁰ Norfolk
Island set-
tled.

* See Nor-
folk Island.

¹¹ Broken
Bay exam-
ined.

In the beginning of March the governor went out with a small party to examine Broken Bay, lying about eight miles to the northward of Port Jackson. This was found very extensive, with many openings. One of the latter ended in several small branches, and a large lagoon, which they could not at that time examine. Most of the land about the upper part of this branch was low and full of swamps, with great numbers of pelicans, and other aquatic birds. Among the rest they met with an uncommon bird, called at that time the *Hooded Gull*, but afterwards found to be the species named by Mr Latham the *Caspian Tern*.

From this north-west branch they proceeded across the bay to the south-west branch, which is also very extensive, with a second opening to the westward capable of affording shelter to almost any number of ships, with depth of water for vessels of almost any burden. The land was found much higher here than at Port Jackson, more rocky, and equally covered with timber. Large trees were seen growing even on the summits of the mountains, which appeared totally inaccessible to the human species. Round the headland which forms the southern entrance into the bay is a third branch, which Governor Phillip thought the finest piece of water he had ever seen; which for that reason he honoured with the name of *Pitt-water*. This branch, as well as the former, is sufficient to contain all the navy of Great Britain; but the latter has a bar at the entrance of only 18 feet at low water. Within are from 7 to 15 fathoms. The land here is more level than on the south-west branch, and some situations are proper for cultivation. The governor determined to have returned by land, in order to explore the country betwixt Port Jackson and Broken Bay, but the continual rains prevented him.

On the 10th of March the French ships departed,

little intercourse having passed between them and the English during the time of their stay. While the former remained in Botany Bay, Father la Receveur, who had come out in the *Astrolabe* as a naturalist, died of the wounds he had received in the battle with the inhabitants of Masuna. A kind of monument was erected to his memory, with the following inscription:

¹² New Hol-
land. Death of
J. A. Rece-
veur.

Hic jacet LA RECEVEUR
E. F. F. minimis Gallix sacerdos,
Physicus in circumnavigatione
Mundi
Duce DE LA PEYROUSE,
Ob. 17. Feb. 1788.

This monument, however, was soon after destroyed by the natives; on which Governor Phillip caused the inscription to be engraved on copper and nailed to a neighbouring tree. M. de la Peyrouse had paid a similar tribute to the memory of Captain Clerke at Kamtschatka.

On the 15th of April, the governor, attended by several officers and a small party of marines, set out on an expedition into the interior parts of the country. Their first landing was at the head of a small cove named *Shell-cove*, near the entrance of the harbour on the north side. Proceeding in this direction, they arrived with great labour at a large lake, surrounded on all sides with bog and marshy ground to a considerable extent, and in which they frequently plunged up to the waist. Here they observed that bird so rare in other parts of the world, viz. a black swan. On being fired at, it rose, and shewed that its wings were edged with white, the bill being tinged red. They spent three days in a very laborious manner in passing the marshes and swamps which lie in the neighbourhood of the harbour: and here they had an opportunity of observing, that all the small streams which descend into Port Jackson proceed from swamps, occasioned by the stagnation of the water in the low grounds as it rises from the springs. On leaving these low grounds, they found them succeeded by a rocky and barren country; the hills covered with various flowering shrubs, though frequently inaccessible by reason of various natural obstacles. At about 15 miles distance from the sea, the governor had a fine view of the internal parts of the country, which were mountainous. To the most northerly chain of these he gave the name of *Carmarthen*, and to the most southerly that of *Lansdown Hills*; and to one which lay between these he gave the name of *Richmond Hill*. It was conjectured, that a large river must rise from these mountains; but there was now a necessity for returning. On the 22d, however, another expedition was undertaken. Governor Phillip with his party landed near the head of the harbour. Here they found a good country; but in a short time arrived at a close thicket through which they found it impossible to make their way, so that they were obliged to return. Next day, by keeping close to the banks of a small creek, they made a shift to pass that obstacle, and continued their course for three days to the westward. The country was now extremely fine, either entirely level or rising in small hills; the soil excellent, but stony in a few places. The trees grew at the distance of from 20 to 40 feet from each other, in general totally destitute of underwood, which was confined to the barren and stony spots.

¹³ Excursions
into the
interior
part of the
country.

New Hol-
land.

spots. On the 5th day they saw for the first time in this second expedition Carmarthen and Lansdown hills; but the country all round was so beautiful, that Governor Phillip gave it the name of *Belle Vue*. They were still apparently 30 miles from the mountains which they had intended to reach; but not having been able to carry more than six days provisions along with them, they found it necessary to return; and even with this small stock the officers as well as men were obliged to carry heavy loads. During all this time they had not proceeded farther in a direct line than 30 miles, so great were the obstructions they had met with from deep ravines, &c. Their return, however, was effected with much greater ease, having cleared a track, and marked trees all the way as they went along to direct them in their journey back. The country explored at this time appeared so fine, that Governor Phillip determined to form a settlement there as soon as a sufficient number could be spared from those works which were immediately necessary. On his return he had the mortification to find, that five ewes and a lamb had been killed very near the camp, and in the middle of the day. This mischief was supposed to have been done by some dogs belonging to the natives.

All this time the scurvy had continued to rage with great violence: so that by the beginning of May near 200 people were incapable of work. For this reason, and on account of the great difficulty of clearing the ground, no more than eight or ten acres of wheat and barley had been sown, besides what private individuals had sown for themselves; and it was even feared that this small crop would suffer from the depredations of ants and field mice. To procure as much relief as possible therefore in the present exigence, the Supply was sent in the beginning of May to Lord Howe Island, in hopes of procuring some turtle and other provisions; but unfortunately the vessel returned without any turtle, having met with squally weather, and being obliged to cut away her best bower anchor. The natives now began to show an hostile disposition, which they had not hitherto done. One of the convicts, who had wandered away from the rest in quest of vegetables, returned with a very dangerous wound in the back; giving information also, that another who had gone out for the same purpose had been carried off in his sight by the natives, after being wounded in the head. A shirt and hat were afterwards found in some of the huts of the natives, but no intelligence of the man could be gained. This was followed by other misfortunes of the same nature. On the 30th of the month, two men who had been employed in cutting rushes for thatch at some distance from the camp were found dead. One of them had four spears in his body, one of which had pierced quite through it; but the other had no marks of violence upon him. In this case, however, it was proved, that those who suffered had been the aggressors; as they had been seen with one of the canoes of the natives which they had taken from one of the fishing places. All possible inquiry was made after the natives who had been guilty of the murder, but to no purpose. In the course of this inquiry, it was found that one of the natives had been murdered, and several wounded, previous to the attack upon the rush-cutters. The governor promised liberty to any convict who should discover the aggressors; but no information was

14
Murders
committed
by the na-
tives.

procured, though it is probable that it may prevent accidents of that kind for the future. About this time the two bulls and four cows belonging to government and to the governor, having been left for some time by the man who had the charge of them, strayed into the woods and could not be recovered, though they were afterwards traced to some distance.

The 4th of June being his majesty's birth-day, was celebrated with as much festivity as circumstances would allow; and on this occasion it was first made public that the governor had given the name of *Cumberland County* to this part of the territory. The appointed boundaries were Carmarthen and Lansdown hills on the west, the northern parts of Broken Bay on the north, and the southern parts of Botany Bay on the south; thus including these three principal bays, with Sydney Cove nearly in the centre.

The misfortune which attended those convicts who strayed to too great a distance from the settlement, were not sufficient to prevent some of them from rambling into the woods, in hopes of subsisting themselves there and regaining their liberty. One of these, who had been guilty of a robbery, fled into the woods on the 5th of June, but was obliged to return half-starved on the 24th. He had found it impossible to subsist in the woods, and had met with very little relief from the natives. One of them gave him a fish, but made signs for him to go away. According to his account, they themselves were in a very miserable situation; and he pretended to have seen four of them apparently dying of hunger, who made signs to him for something to eat. He pretended also to have fallen in with a party who would have burnt him, and that he made his escape from them with difficulty. He said also, that he had seen the remains of a human body lying on a fire; and endeavoured to inculcate the idea of these savages eating human flesh when other provisions were scarce. This poor wretch was tried and executed for the theft he had committed before his departure, along with another criminal.

By this time the colony was so far advanced, that the plan of a regular town had been marked out. The principal street, when finished, is to be 200 feet wide, terminated by the governor's house, the main guard, and criminal court. The plans of other streets are likewise marked out; and it is the governor's intention, that when houses are built here, the grants of land shall be made with such clauses as will prevent the building of more than one house on one allotment, which is to consist of 60 feet in front and 150 in depth. Thus a kind of uniformity will be preserved in the building, narrow streets prevented, and many inconveniences avoided, which a rapid increase of inhabitants might otherwise occasion. It has likewise been an object of the governor's attention to place the public buildings in such situations as will be eligible at all times, and particularly to give the store-houses and hospital sufficient space for future enlargement, should it be found necessary. The first huts erected in this place were composed only of the soft wood of the cabbage palm, in order to give immediate shelter, and which had the further inconvenience of being used quite green. The huts of the convicts were constructed only of upright posts wattled with slight twigs, and plastered up with clay. Buildings of stone might easily have

New Hol-
land.15
A convict
executed.16
Regular
plan of a
town laid.

New Hol-
land. been raised, had there been any means of procuring lime for mortar. There were three kinds of stone met with about Sydney Cove, one equal in goodness to Portland stone, an indifferent kind of sandstone or freestone, and a sort which seems to contain iron; but neither chalk nor any species of limestone has yet been discovered. Lime was indeed procured from oyster-shells collected in the neighbouring coves to construct a small house for the governor; but it cannot be expected that a sufficient quantity can thus be procured for many or very extensive buildings. Good clay for bricks has been found near Sydney Cove, and very good bricks have been made of it; the wood also, notwithstanding the many reports to the contrary, is found abundantly fit for various purposes after being thoroughly seasoned. Such specimens as have been sent to England were fine-grained and free of knots, but heavy.

On the point of land that forms the west side of the Cove a small observatory has been erected, the longitude of which has been ascertained to be $159^{\circ} 19' 30''$ east from Greenwich, and the latitude $32^{\circ} 52' 30''$ south. Instead of thatch they now make use of shingles made from a certain tree, which has the appearance of a fir, but produces wood like English oak.

With regard to the state of this colony there have been various and discordant accounts. Some of these have represented the country in such a light, that it would seem impossible to subsist on it; and it has been said, that the people who have had the misfortune to go there already were in the utmost danger of starving before any assistance could be sent from Britain. These reports, however, appear not to be well founded. Difficulties must undoubtedly be felt at the first settlement of every uninhabited country; and we are not to expect that a colony, most of whom are wretches exiled for their crimes from their own country, can thrive in an extraordinary manner for some time. It appears, indeed, that so far from the transportation to this place having had any good effect in reforming them, the governor has been obliged to execute the utmost rigour of the law by hanging several of them. A good number of others have unaccountably disappeared, and are supposed to have been murdered by the natives, or perished with hunger in the woods; so that, unless the numbers be recruited by more respectable inhabitants, it is not likely that much can be expected from the Port Jackson settlement for a long time to come. Of this, however, there seems to be little doubt: the general spirit of emigration which prevails through most, indeed we may say all the countries of Europe, will undoubtedly soon supply a sufficient number; and even some of the Americans, notwithstanding the extent and fertility of their own country, and the liberty they enjoy in it, are said to be willing to exchange these blessings for the precarious hopes of what may be obtained in New Holland among British convicts and slaves. This rambling disposition may perhaps be accounted for from an observation which has been made, viz. that "it may admit of a doubt whether many of the accommodations of a civilized life be not more than counterbalanced by the artificial wants to which they give birth. That these accommodations do not give a satisfaction equivalent

to the trouble with which they are procured, is certain; and it is no wonder, then, to find numbers of people in every country who are willing to exchange them for independent ease and tranquillity, which belong, comparatively speaking, to few individuals in those countries which are called civilized."

With regard to the geography of this extensive General country, which may perhaps be reckoned a fifth general account of the country. division of the world, Captains Cook and Furneaux so fully explored its coast, that succeeding navigators have added little to their labours. What they left unfinished has been completed by Captain Flinders, whose laborious and accurate survey of the coast leaves little more to be desired. The discovery of Bass's straits has completed our idea of the general outline of the coast; and, in future, discoveries of importance can only be looked for in the interior.

A vast chain of lofty mountains runs nearly in a north and south direction farther than the eye can trace, about 60 miles inland. The general face of the country is pleasing, diversified with gentle risings and small winding valleys, covered for the most part with large spreading trees, affording a succession of leaves in all seasons. A variety of flowering shrubs, almost all entirely new to an European, and of exquisite fragrance, abound in those places which are free from trees; and among these, a tall shrub, bearing an elegant flower which smells like English may, is peculiarly delightful, and perfumes the air to a great distance. There are but few trees; and, as Captain Tench and others relate, of so bad a grain, that they can scarcely be used for any purpose: This, however, Mr Stockdale Red and ascribes to their being used in an unseasoned state, as yellow has been already mentioned. In return for these bad qualities, however, the trees yield vast quantities of the gum already mentioned as a cure for the dysentery. It is of an acrid quality, and therefore requires to be given along with opiates. The tree which yields it is of very considerable size, and grows to a great height before it puts out any branches. The gum itself is usually compared to *sanguis draconis*, but differs from it in being perfectly soluble in water, which the *sanguis draconis* is not. It may be extracted from the wood by tapping, or taken out of the veins when dry. The leaves are narrow, and not unlike those of a willow; the wood fine-grained and heavy; but warps to such a degree, when not properly seasoned, as soon to become entirely useless.

The yellow gum is properly a resin, being entirely insoluble in water. It greatly resembles gamboge, but has not the property of staining. It is produced by a low small plant with long grassy leaves; but the fructification shoots out in a surprising manner from the centre of the leaves on a single straight stem to the height of 12 or 14 feet. This stem is strong and light, and is used by the natives for making their spears. The resin is generally dug up from the soil under the tree, not collected from it, and may perhaps be the same as Tasman calls *gum lac of the ground*. It has been tried by Dr Blane physician to St Thomas's hospital, who found it very efficacious in the cure of old fluxes, and that in many and obstinate cases. Many of the New Holland plants have been already imported into Britain, and are now flourishing in perfection.

New Hol- section at the nursery garden of Mr Lee of Hammer-
land. smith.

The soil immediately around Sydney Cove is sandy, with here and there a stratum of clay; but hitherto the produce has not been remarkable. The principal difficulty hitherto experienced in clearing the ground arises from the size of the trees, which is said to be so enormous, that 12 men have been employed for five days in grubbing up one. Captain Cook speaks of some fine meadows about Botany Bay; but none of these have been seen by the present settlers, and Governor Phillip supposes them to have been swamps seen at a distance. Grass grows in almost every place, but in the swamps with the greatest vigour and luxuriance, though not of the finest quality. It is found to agree better with cows and horses than sheep. A few wild fruits are sometimes procured; among which is a kind of small purple apple mentioned by Captain Cook; and a fruit which has the appearance of a grape, but tasting like a green gooseberry, and excessively sour.

20
Scarcity of
fresh wa-
ter.

From the first discovery of this continent, the extreme scarcity of fresh water has been mentioned by every navigator. None have been fortunate enough to enter the mouth of any navigable river such as might be expected in a country of such extent. The settlers about Port Jackson found enough for the common purposes of life; but Captain Tench informs us, that when he left the country, towards the end of 1788, there had been no discovery of a stream large enough to turn a mill. Since that time, however, Governor Phillip has been more successful; as we are informed by a letter of his to Lord Sydney, of date February 13. 1790: In this letter he relates, that soon after the ships sailed in Nov. 1788, he again made an excursion to Botany Bay, where he staid five days; but the researches he made there tended only to confirm him in the opinion he already entertained that the country round it was by no means an eligible situation for a colony. After having visited Broken Bay several times with boats, a river was found, which has since been traced, and all those branches explored, which afforded any depth of water. This river has obtained the name of *Hawkesbury*, is from 300 to 800 feet wide, and seems navigable for the largest merchant ships as far up as Richmond hill, at which it becomes very shallow, and divides into two branches; on which account the governor calls Richmond hill the head of the river. As after very heavy rains, however, the water sometimes rises 30 feet above its level, it would not be safe for ships to go up so far; but 15 or 20 miles below it they would lie in fresh water, and be perfectly safe.

21
Rivers dis-
covered by
Captain
Phillip.

The country about Broken Bay is at first high and rocky, but as we proceed up the river it becomes more level, the banks being covered with timber, and the soil a light rich mould, supposed to be very capable of cultivation. The other branches of this river are shallow, but probably run many miles up into the country. Great number of black swans and wild ducks were seen on these rivers, and the natives had several decoys for catching quails.

Richmond hill, near which a fall prevented the boats from proceeding farther up, is the most southerly of a large range of hills which run to the northward, and

probably join the mountains nearly parallel to the coast from 50 to 60 miles inland. The soil of this hill is good, and it lies well for cultivation. There is a very extensive prospect from the top, the whole country around seeming a level covered with timber. There is a flat of six or seven miles between Richmond hill and a break in the mountains which separates Lansdown and Carmarthen hills; in which flat the governor supposes that the *Hawkesbury* continues its course; though the river could not be seen on account of the timber with which the ground is everywhere covered where the soil is good. Six miles to the southward of Port Jackson is a small river; and 20 to the westward is one more considerable, which probably empties itself into the *Hawkesbury*. As far as this river was at that time explored, the breadth was computed at from 300 to 400 feet. It was named the *Nepean*, and, like the *Hawkesbury*, sometimes rises 30 feet above its level. A party who crossed the river attempted to reach the mountains, but found it impossible, probably for want of provisions. After the first day's journey they met with such a succession of deep ravines, the sides of which were frequently so inaccessible, that in five days they could not proceed farther than 15 miles. At the time they turned back, they supposed themselves to be 12 miles from the foot of the mountains. With regard to the state of the colony, it appears from this letter to be as flourishing as could in any reasonable manner be expected. Another has been formed at a place called *Rosehill*, at the head of the harbour of Sydney Cove. At this place is a creek, which at half flood has water for large boats to go three miles up; and one mile higher the water is fresh and the soil good. Some ground having been cleared and cultivated, the governor in the above letter writes, that 27 acres were sown with corn, and that in December the crop was got in: That the corn was exceedingly good; about 200 bushels of wheat and 60 of barley, with a small quantity of flax, Indian corn, and oats; all which is preserved for seed: That if settlers are sent out, and the convicts divided amongst them, this settlement will very shortly maintain itself; but without which this country cannot be cultivated to any advantage. "At present (continues the governor) I have only one person, who has about 100 convicts under his direction, who is employed in cultivating the ground for the public benefit, and he has returned the quantity of corn above mentioned into the public store: the officers have raised sufficient to support the little stock they have: some ground I have had in cultivation will return about 40 bushels of wheat into store; so that the produce of the labour of the convicts employed in cultivation has been very short of what might have been expected, and which I take the liberty of pointing out to your lordship in this place; to show as fully as possible the state of this colony, and the necessity of the convicts being employed by those who have an interest in their labour." The country for 20 miles to the westward is very capable of cultivation; though the labour of cutting down the trees is very great. At Sydney Cove the stores had been infested by a swarm of rats which destroyed no less than 12,000 lb. weight of flour and rice. The gardens also had suffered very considerably; so that, having met with such a considerable

New Hol-
land.

New Hol- of provision, and a sufficient supply not being procured
land. from the Cape, Governor Phillip thought proper to
send a further detachment to Norfolk Island, where the
fertility of the soil afforded great hopes of their being
able in a short time to subsist themselves independent
of any assistance from the stores.

11 Govern- In the year 1813 a few private individuals made an
ment of the excursion across the Blue mountains, and discovered
colony. Macquarrie river flowing to the north-west, through a
rich, beautiful, undulating country. After a road was
made, the governor himself visited this newly discov-
ered region; and founded the town of Bathurst on the
river, about seventy miles from its source. This new
establishment has prospered greatly. The land yields
excellent crops; and the cattle are found to thrive ex-
tremely. The direction of Macquarrie river away
from the nearest sea coast, into the vast interior of the
country, gave rise to many speculations; and the
Lachlan, another river, having a similar course, was
found out shortly after. Two successive expeditions,
conducted by Mr Oxley, were fitted out in 1817, to
explore the country farther west. The result, however,
disappointed the sanguine expectations entertained.
The Macquarrie, after being traced for two or three
hundred miles, and the Lachlan for a greater distance,
were found to terminate in a vast extended marsh.
The soil, as they approached this marsh, became gra-
dually worse; and the hills sunk by degrees till the
country became a dreary flat. A great extent of ex-
cellent land however has been ascertained to exist on
the upper part of the Macquarrie; and to this district
the eyes of the colonists are now directed.

With regard to the civil establishment in this colony,
Governor Phillip's jurisdiction extends from 43° 49' to
10° 37' south, being the northern and southern extremi-
ties of the continent. It commences again in 135° E.
Long. from Greenwich; and proceeding in an easterly
direction, includes all the islands within the above-
mentioned latitudes in the Pacific ocean; by which
partition it is supposed that every source of litigation
will be cut off, as all these are indisputably the discov-
ery of the British navigators.

The powers of the governor are absolutely unlim-
ited, no mention being made of a council to assist him
in any thing; and as no stated time is appointed for
assembling the courts similar to the assizes and gaol
deliveries in England, the duration of imprisonment
is altogether in his hands. He is likewise invested
with a power of summoning general courts martial;
but the insertion in the marine mutiny act, of a smal-
ler number of officers than 13 being able to compose
such a tribunal, has been neglected; so that a military
court, should detachments be made from head quar-
ters, or sickness prevail, may not always be found
practicable to be obtained, unless the number of officers
in the settlement at present be increased. The gover-
nor is allowed to grant pardons in all cases, treason and
willful murder excepted; and even in these he has au-
thority to stay the execution of the law until the king's
pleasure shall be signified. In case of the governor's
death, the lieutenant governor takes his place; and on
his decease, the authority is lodged in the hands of the
senior officer.

It was not long after the convicts were landed that
there appeared a necessity for assembling a criminal

New Hol- court; and it was accordingly convened by warrant New Hol-
land. from the governor. The members were the judge ad-
vocate, who presided, three naval, and three military
officers. The number of members is limited by act of
parliament to seven; who are expressly ordered to be
officers either of his majesty's sea or land forces. The
court being met, completely arrayed and armed as at
a military tribunal, the judge advocate proceeds to ad-
minister the usual oaths taken by jurymen in England
to each member; one of whom afterwards swears him
in a like manner. The ceremony being over, the
crime is laid to the prisoner's charge, and the question
"guilty or not guilty" put to him. No law officer
being appointed on the part of the crown, the party
at whose suit he is tried is left to prosecute the pri-
soner entirely by himself. All the witnesses are ex-
amined on oath; and the decision must be given accord-
ing to the laws of England, or "as nearly as may be,
allowing for the circumstances and situation of the settle-
ment," by a majority of votes, beginning with the
youngest member, and ending with the president of
the court. No verdict, however, can be given in
cases of a capital nature, unless at least five of the
seven members concur therein. The evidence on both
sides being finished, and the prisoner's defence heard,
the court is cleared, and, on the judgment being set-
tled, is thrown open again, and sentence pronounced.
During the time of sitting, the place in which it is
assembled is directed to be surrounded by a guard un-
der arms, and admission granted to every one who
chooses to enter it.

The first trials which came before this court were¹³ Trials of
those of three convicts, one of whom was convicted^{convicts,}
of having struck a marine with a cooper's adze, and^{&c.}
behaving otherwise in a most scandalous and riotous
manner. For this he was condemned to receive 150
lashes, being a smaller punishment than a soldier would
have suffered in a similar case. A second, for having
committed a petty theft, was sent to a small barren
island, and kept there on bread and water only for a
week. The third was sentenced to receive 50 lashes;
but being recommended by the court to the governor,
had his sentence remitted. The same lenity, however,
could not be observed in all cases. One fellow, who
had been condemned to be hanged, was pardoned
while the rope was about his neck, on condition that
he would become the common executioner ever after.
He accepted the horrid office, but not without a *pause*.
Some examples of severity were undoubtedly necessary;
and among these it is impossible to avoid feeling some
regret for the fate of one who suffered death for steal-
ing a piece of soap of eight pence value: but by a letter
of Governor Phillip, we are informed that the con-
victs in general had begun to behave much better;
more so indeed than ever he expected; and at this
time one woman had suffered for a robbery; five chil-
dren had died, and 28 had been born. The whole
amount of the deaths 77, of the births 87.

Besides the criminal court, there is an inferior one,
composed of the judge advocate, and one or more
justices of the peace, for the trial of small misdemeanors.
This court is likewise empowered to decide all law-
suits; and its verdict is final, except where the sum ex-
ceeds 300l. in which case an appeal can be made to
England from its decree. In case of necessity, an

New Holland. admiralty court, of which the lieutenant governor is judge, may also be summoned for the trial of offences committed on the high seas.

²⁴
Animals found in New Holland.

The quadrupeds on the continent of New Holland hitherto discovered, are principally of the opossum kind, of which the most remarkable is the kangaroo. There is also a species of dogs very different from those known in Europe. They are extremely fierce, and never can be brought to the same degree of familiarity with those we are acquainted with. Some of them have been brought to England, but still retain their usual ferocity. There are a great many beautiful birds of various kinds; among which the principal are the black swans already mentioned, and the ostrich or cassowary; which last arrives frequently at the height of seven feet or more. Several kinds of serpents, large spiders, and scolopendras, have also been met with. There are likewise many curious fishes; though the finny tribe seem not to be so plentiful on the coast as to give any considerable assistance in the way of provisions for the colony. Some very large sharks have been seen in Port Jackson, and two smaller species, one named the Port Jackson shark, the other Watta's shark. The latter, notwithstanding its diminutive size, the mouth scarce exceeding an inch in breadth, is excessively voracious. One of them having been taken and flung down upon the deck, lay there quiet for *two hours*; after which Mr Watta's dog happening to pass by, the fish sprung upon it with all the ferocity imaginable, and seized it by the leg in such a manner that the animal could not disengage himself without assistance.

²⁵
Climate.

The climate of this continent appears not to be disagreeable, notwithstanding the violent complaints which some have made about it. The heat has never been excessive in summer, nor is the cold intolerable in winter. Storms of thunder and lightning are frequent; but these are common to all warm countries; and it has been supposed, (though upon what foundation does not well appear) that were the country cleared of wood, and inhabited, these would in a great measure cease. A shock of an earthquake has likewise been felt; but these natural calamities are incident to some of the finest countries in the world. It is not known whether or not there are any volcanoes.

²⁶
Account of the inhabitants.

The inhabitants of New Holland are by all accounts represented as the most miserable and savage race of mortals perhaps existing on the face of the earth. They go entirely naked; and though pleased at first with some ornaments which were given them, they soon threw them away as useless. It does not appear, however, that they are insensible of the benefits of clothing, or of some of the conveniences which their new neighbours are in possession of. Some of them, whom the colonists partly clothed, seemed to be pleased with the comfortable warmth they derived from it; and they all express a great desire for the iron tools which they see their neighbours make use of. Their colour, in the opinion of Captain Cook, is rather a deep chocolate than a full black; but the filth with which their skins are covered, prevents the true colour of them from appearing. At some of their interviews with the colonists, several droll instances happened of their mistaking the negroes among the colonists for their own countrymen. Notwithstanding their disregard for European

finery, they are fond of adorning, or rather deforning, their bodies with scars; so that some of them cut the most hideous figure that can be imagined. The scars themselves have an uncommon appearance. Sometimes the skin is raised several inches from the flesh, and appears as if filled with wind; and all these seem to be reckoned marks of honour among them. Some of them perforate the cartilage of the nose, and thrust a large bone through it, a hideous kind of ornament, humorously called by the sailors their *sprit-sail yard*. Their hair is generally so much clotted with the red gum already mentioned, that they resemble a mop. They also paint themselves with various colours like most other savages; they will also sometimes ornament themselves with beads and shells, but make no use of the beautiful feathers procurable from the birds of the country. Most of the men want one of the fore-teeth in the upper jaw; a circumstance mentioned by Dampier and other navigators; and this also appears to be a badge of honour among them. It is very common among the women to cut off the two lower joints of the little finger; which, considering the clumsiness of the amputating instruments they possess, must certainly be a very painful operation. This was at first supposed to be peculiar to the married women, or those who had born children; but some of the oldest women were found without this distinction, while it was observed in others who were very young.

The New Hollanders appear extremely deficient in the useful arts. Of the cultivation of the ground they have no notion; nor can they even be prevailed upon to eat bread or dressed meat. Hence they depend entirely for subsistence on the fruits and roots they can gather, with the fish they catch. Governor Phillip also mentions their frequent setting fire to the grass, in order to drive out the opossums and other animals from their retreats; and we have already taken notice of their using decoys for geese. As all these resources, however, must be at best precarious, it is no wonder that they are frequently distressed for provisions. Thus, in the summer-time, they would eat neither the shark nor sting-ray; but in winter any thing was acceptable. A young whale being driven ashore, was quickly cut in pieces and carried off. They broiled it only long enough to scorch the outside, and in this raw state they eat all their fish. They broil also the fern root and another whose species is unknown. Among the fruits used by them is a kind of wild fig; and they eat also the kernels of a fruit resembling the pine apple. The principal part of their subsistence, however, is fish; and when these happened to be scarce, they were wont to watch the opportunity when the colonists hauled the seine, and often seized the whole, though a part had formerly been offered or given them. They sometimes strike the fish from the canoes with their spears, sometimes catch them with hooks, and also make use of nets, contrary to the assertion of Dr Hawkesworth, who says that none of these are to be met with among them. Their nets are generally made of the fibres of the flax plant, with very little preparation, and are strong and heavy; the lines of which they are composed twisted like whip-cord. Some of them, however, appear to be made of the fur of an animal, and others of cotton. The meshes of their nets are made of very large loops artificially inserted into each other,

but

but without any knots. Their hooks are made of the inside of a shell very much resembling mother-of-pearl. The canoes in which they fish are nothing more than large pieces of bark tied up at both ends with vines; and considering the slight texture of these vessels, we cannot but admire the dexterity with which they are managed, and the boldness with which they venture in them out to sea. They generally carry fire along with them in these canoes, to dress their fish when caught. When fishing with the hook, if the fish appears too strong to be drawn ashore by the line, the canoe is paddled to the shore; and while one man gently draws the fish along, another stands ready to strike it with a spear, in which he generally succeeds. There is no good season for supposing them to be cannibals, and they never eat animal substances but raw or next to it. Some of their vegetables are poisonous when raw, but deprived of this property when boiled. A convict unhappily experienced this by eating them in an unprepared state; in consequence of which he died in 24 hours. The dislike of the New Hollanders to the European provisions has already been mentioned: if bread be given them, they chew and spit it out again, seldom choosing to swallow it. They like salt beef and pork rather better; but they could never be brought to taste spirits a second time.

The huts of these savages are formed in the most rude and barbarous manner that can be imagined. They consist only of pieces of bark laid together in the form of an oven, open at one end, and very low, though long enough for a man to lie at full length. There is reason, however, to believe, that they depend less on them for shelter than on the caverns with which the rocks abound. They go invariably naked, as has already been observed; though we must not imagine that the custom of going naked inures them so to the climate as to make them insensible to the injuries of the weather. The colonists had repeated opportunities of observing this, by seeing them shivering with cold in the winter time, or huddling together in heaps in their huts or in caverns, till a fire could be kindled to warm them. It is probable, however, notwithstanding their extreme barbarity, that some knowledge of the arts will soon be introduced among them, as some have been seen attentively considering the utensils and conveniences of the Europeans, with a view, seemingly, of making similar improvements of their own. It has also been observed, that in some things they possess a very great power of imitation. They can imitate the songs and language of the Europeans almost instantaneously, much better than the latter can imitate theirs by long practice. Their talent for imitation is also discernible in their sculptures representing men and other animals everywhere met with on the rocks; which, though rude, are very surprising for people who have not the knowledge even of constructing habitations in the least comfortable for themselves, or even clothes to preserve them from the cold.

In their persons, the new Hollanders are active, vigorous, and stout, though generally lean. Dampier asserts that they have a dimness of sight; though later navigators have determined this to be a mistake, ascribing to them, on the contrary, a quick and piercing

sight. Their sense of smelling is also very acute. One of them having touched a piece of pork, held out his finger for his companion to smell with strong marks of disgust. The only kind of food they eagerly accept of is fish. Their behaviour with regard to the women has been hitherto unaccountable to the colonists. Few of them, comparatively speaking, have been seen, and these have sometimes kept back with the most jealous sensibility; sometimes offered with the greatest familiarity. Such of the females as have been seen, have soft and pleasing voices; and notwithstanding their barbarism and excessive rudeness, seem not to be entirely destitute of modesty.

The New Hollanders generally display great personal bravery on the appearance of any danger. An old man, whom Governor Phillip had treated with some familiarity, took occasion to steal a spade; but being taken in the fact, the governor gave him a few slight slaps on the shoulder; on which the old man caught hold of a spear, and coming up to him, seemed for some time determined to strike, though had he done so, it would have been impossible for him to escape, being then surrounded by the officers and soldiers. No encounters between parties of the natives themselves have been observed, though from some circumstances it appears that wars are carried on among them. They have more than once been seen assembled as if bent on some expedition. An officer one day met 14 of them marching along in a regular Indian file through the woods, each man having a spear in one hand and a stone in the other. A chief appeared at their head, who was distinguished from the rest by being painted. They passed on peaceably, though greatly superior in number to our people. On another occasion they offered no hostilities when assembled to the number of 200 or 300, and meeting the governor attended only by a small party. With all their courage, however, they are much afraid of a musket, and almost equally so of a red coat, which they know to be the martial dress of the Europeans. The mischief which they have hitherto done has been exercised only on some straggling convicts, most of whom probably have been the first aggressors.

Though these savages allow their beards to grow to a considerable length, it does not appear that they look upon them to be any ornament, but rather the contrary, as appears from the following instance. Some young gentlemen belonging to the *Sirius*, one day met an old man in the woods with a beard of considerable length. This his new acquaintance let him know that they would rid him of, stroking their chins, and showing him the smoothness of them at the same time. At length the old fellow consented; and one of the youngsters taking a penknife from his pocket, and making the best substitute for lather he could, performed the operation with such success, that the Indian seemed highly delighted. In a few days he paddled alongside of the *Sirius* again, pointing to his beard; but could not by any means be prevailed upon to enter the ship. On this a barber was sent down to him, who again freed him from his beard, at which he expressed the utmost satisfaction. It has, however, been found impossible to form any kind of permanent intercourse with the natives, though many

New Hol-
land.

New Hol-
land.

attempts have been made for that purpose; but in his letter above quoted, Governor Phillip declares that he has not the least apprehension of their doing any damage to the colony. At first the colonists imagined the spears of the New Hollanders to be very trivial weapons; but it now appears that they are capable of inflicting very grievous and mortal wounds. They are sometimes pointed with a sharp piece of the same reed of which the shafts are made, but more frequently with the sharp bone of the sting-ray. They certainly burn their dead, which perhaps has given rise to the report of their being cannibals. Governor Phillip, observing the ground to be raised in several places, caused one of these tumuli to be opened, in which were found a jaw-bone half consumed and some ashes. From the manner in which the ashes are deposited, it appears that the body has been laid at length, raised from the ground a little space, and consumed in that posture, being afterwards lightly covered with mould.

The only domestic animals they have are the dogs already mentioned, which resemble the fox-dog of England. In their language these animals are called *dingo*; but all other quadrupeds without exception they name *kangaroo*.—They seem very little given to thieving in comparison with the inhabitants of most of the South Sea islands; and are very honest among themselves, leaving their spears and other implements open on the beach, in full and perfect security of their remaining untouched. They are very expert at throwing their javelins, and will hit a mark with great certainty at a considerable distance; and it seems that sometimes they kill the kangaroo with this weapon, as a long splinter of one of the spears was taken out of the thigh of one of these animals, the flesh having closed over it completely. The people are more numerous than was at first imagined, though still the number of inhabitants must be accounted few in comparison to the extent of country; and there is great reason to believe that the interior parts are uninhabited.

The New Hollanders bake their provisions by the help of hot stones, like the inhabitants of the South Sea islands. They produce fire with great facility according to Captain Cook, but with difficulty according to later accounts, and spread it in a wonderful manner. To produce it, they take two pieces of dry soft wood: one is a stick about eight or nine inches long, the other piece is flat. The stick they shape into an obtuse point at one end; and pressing it upon the other, turn it nimbly, by holding it between both their hands, as we do a chocolate mill; often shifting their hands up, and then moving them down upon it, to increase the pressure as much as possible. By this method they get fire in less than two minutes, and from the smallest spark they increase it with great speed and dexterity. "We have often seen (says Captain Cook) one of them run along the shore, to all appearance with nothing in his hand, who stooping down for a moment, at the distance of every fifty or an hundred yards, left fire behind him, as we could see, first by the smoke, and then by the flame along the drift of wood and other litter which was scattered along the place. We had the curiosity to examine one of these planters of fire when he set off, and we saw him wrap up a small spark in dry grass, which, when he had run a little way, having been fanned by the air that his

motion produced, began to blaze; he then laid it down in a place convenient for his purpose, inclosing a spark of it in another quantity of grass, and so continued his course."

Besides the black swans already mentioned, which the ancients despaired of ever seeing, this country produces that beautiful bird called *menura superba*, of which an interesting description is given by Mr Collins, in the second volume of his Account of the English Colony. Here also there is a considerable number of very uncommon and exquisitely fragrant shrubs. There is also an extraordinary amphibious animal found here, called the *ornithorynchus paradoxus*, of which Mr Home has given a description, which was published in the Philosophical Transactions for 1801.

In 1801, there were in circulation the following coins, which were made legal tenders by authority of the governor.

	L.	s.	d.
A guinea,	-	-	1 2 0
A johannes,	-	-	4 0 0
A half do.	-	-	2 0 0
A ducat,	-	-	0 9 6
A gold mohur,	-	-	1 17 6
A pagoda,	-	-	0 8 0
A Spanish dollar,	-	-	0 5 0
A rupee,	-	-	0 2 6
A Dutch gilder,	-	-	0 2 0
An English shilling,	-	-	0 1 1
A copper coin of 1 oz.	-	-	0 0 2
A do. of $\frac{1}{2}$ oz.	-	-	0 0 1
A do. of $\frac{1}{4}$ oz.	-	-	0 0 $\frac{1}{2}$

The successive accounts published of the colony, shew a very rapid progress in wealth and population. At the close of the year 1797 the colony had of live stock, 26 horses, 58 mares, 132 bulls and oxen, 195 cows, 4247 hogs, 743 rams, 1714 sheep, 781 he and 1495 she goats. Of land in a state of cultivation, there were 3361 $\frac{1}{2}$ acres in wheat, 1527 for maize, and 26 $\frac{1}{2}$ in barley, besides a considerable quantity of garden ground, which produced potatoes, callevances, and vines.

From the 27th of January 1788, to the 7th of June 1800, not fewer than 120 ships and vessels of various descriptions, and from different quarters of the globe, have visited this country; a convincing proof that they either found it a place of refreshment after the fatigues of a long voyage, or an advantageous market for their commercial speculations. Thirty-seven of them went from England with convicts, to the number of 5000, of whom about 157 were females.

In the year 1801 the increasing prosperity of the colony was still conspicuous, for the live stock of different individuals consisted of 6269 sheep, 362 cattle, 211 horses, 1259 goats, and 4766 hogs; and what belonged to government consisted of 488 sheep, 931 cattle, and 32 hogs. There were 5324 acres of land sown with wheat, and 3864 acres with maize; and the inhabitants amounted to 6508.

In 1818, the horned cattle amounted to 40,000, the horses to 3300, the sheep to 73,000, and the hogs to 22,000, exclusive of the stock of Van Diemen's Land. The population of the colony, including that of Van Diemen's Land, was 25,000.

HOLLAND,

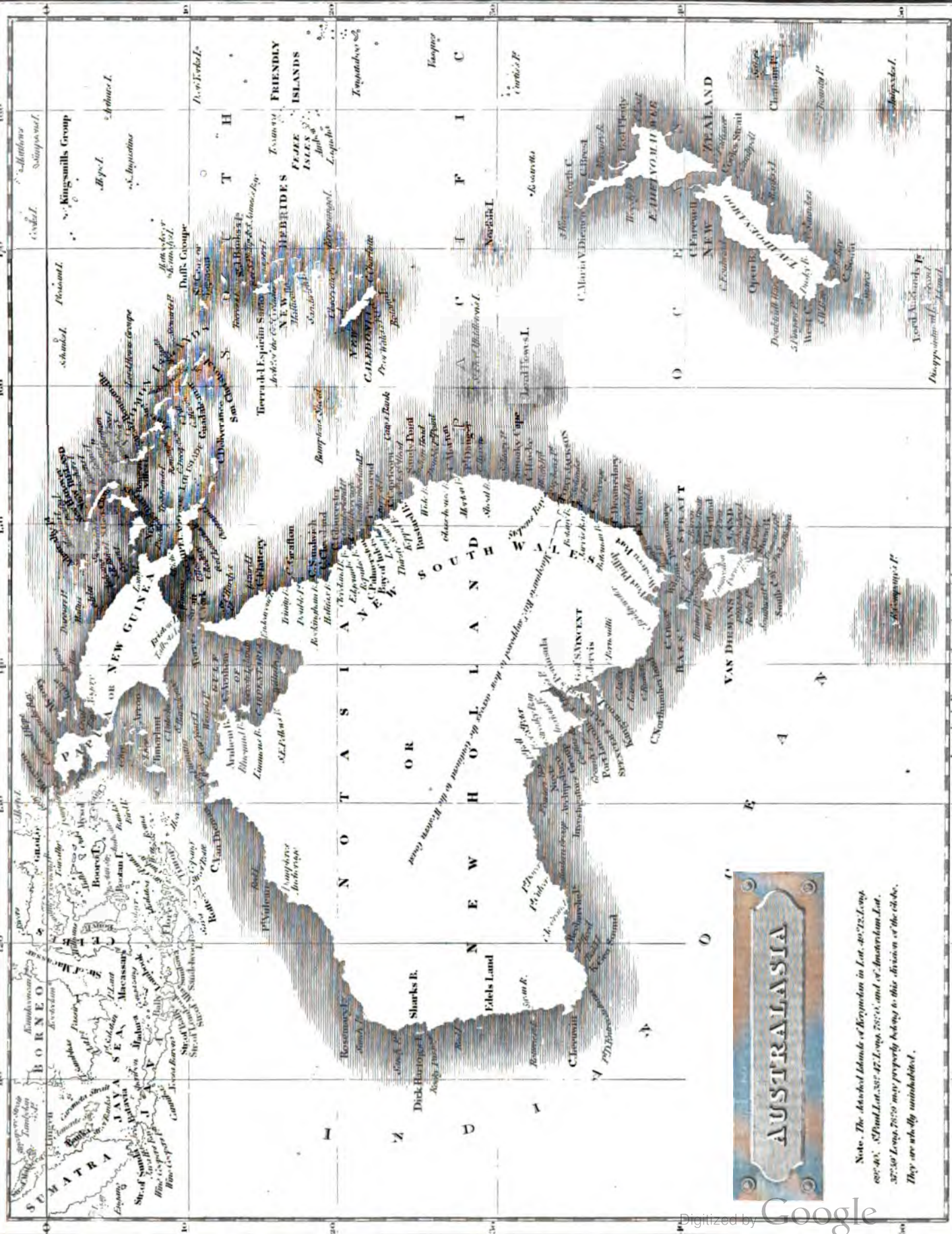

AUSTRALASIA

Note. The dashed Islands of Iroquoia in Lat. 40° 22' Long. 100° 40'. 51° 10' Lat. 50° 47' Long. 75° 50' and of Iroquoia in Lat. 32° 50' Long. 75° 50' may properly belong to this division of the globe. They are hereby unincorporated.

HOLLAND, in commerce, a fine and close kind of linen, so called from its being first manufactured in Holland.

HOLLAR, WENCESLAUS, a celebrated engraver, born at Prague in 1607. His parents were in a genteel line of life; and he was at first designed for the study of the law. But the civil commotions which happened in his youth, ruining his family affairs, he was obliged to shift for himself; and by discovering some genius for the arts, he was placed with Marian, a very able designer and engraver of views. Being himself a man of great ingenuity, he profited hastily from the instruction of his tutor. He principally excelled in drawing geometrical and perspective views and plans of buildings, ancient and modern cities and towns; also landscapes, and every kind of natural and artificial curiosities, which he executed with a pen in a very peculiar style, excellently well adapted to the purpose. He travelled through several of the great cities of Germany: and, notwithstanding all his merit, met with so little encouragement, that he found it very difficult to support himself. The earl of Arundel being in Germany, took him under his protection, brought him to England, and recommended him to the favour of Charles I. He engraved a variety of plates from the Arundel collection, and the portrait of the earl himself on horseback. The civil wars which happened soon after in England, ruined his fortune. He was taken prisoner, with some of the royal party, and with difficulty escaped; when he returned to Antwerp, and joined his old patron the earl of Arundel. He settled in that city for a time, and published a considerable number of plates: but his patron going to Italy soon after for the benefit of his health, Hollar fell again into distress, and was obliged to work for the print and booksellers of Antwerp at very low prices. At the Restoration he returned to England; where, though he had sufficient employment, the prices he received for his engravings were so greatly inadequate to the labour necessarily required, that he could but barely subsist, and the plague, with the succeeding fire of London, putting for some time an effectual stop to business, his affairs were so much embarrassed, that he was never afterwards able to improve his fortune. It is said that he used to work for the booksellers at the rate of fourpence an hour, and always had an hour glass before him. He was so very scrupulously exact, that when obliged to attend the calls of nature, and whilst talking, though with the persons for whom he was working, and about their own business, he constantly laid down the glass to prevent the sand from running. Nevertheless, all his great industry, of which his numerous works bear ample testimony, could not procure him a sufficient maintenance. It is melancholy to add, that on the verge of his 70th year, he was attached with an execution at his lodgings in Gardener's lane, Westminster, when he desired only the liberty of dying in his bed; and that he might not be removed to any other prison than the grave, a favour which it is uncertain whether he obtained or not. He died, however, in 1677.—His works amount nearly to 24,000 prints, according to Vertue's Catalogue, and the lovers of art are always zealous to collect them. Generally speaking, they are etchings performed almost entirely with the point, and

their merits are thus characterized by Mr Strutt: "They possess great spirit, with astonishing freedom and lightness, especially when we consider how highly he has finished some of them. His views of abbeys, churches, ruins, &c. with his shells, muffs, and every species of still life, are admirable; his landscapes frequently have great merit; and his distant views of towns and cities are not only executed in a very accurate, but a very pleasing manner." A somewhat colder character is given of them by Mr Gilpin in his Essay on Prints: "Hollar gives us views of particular places, which he copies with great truth, unornamented as he found them. If we are satisfied with exact representations, we have them nowhere better than in Hollar's works; but if we expect pictures, we must seek them elsewhere. Hollar was an antiquarian and a draughtsman, but seems to have been little acquainted with the principles of painting. Stiffness is his characteristic, and a painful exactness void of taste. His larger views are mere plans. In some of his smaller, at the expence of infinite pains, something of an effect is sometimes produced. But in general, we consider him as a repository of curiosities, a record of antiquated dresses, abolished ceremonies, and edifices now in ruins."

HOLLOA, in the sea language, an exclamation of answer, to any person who calls to another to ask some question, or to give a particular order. Thus if the master intends to give any order to the people in the main-top, he previously calls, *Main top, hoay!* to which they answer, *Holloa!* to show that they hear him and are ready. It is also the answer in hailing a ship at a distance. See **HAILING**.

HOLLY. See **ILEX**, **BOTANY Index**.

Sea-HOLLY. See **ERYNGIUM**, **BOTANY Index**.

HOLM (Sax. *hulmus*, *insula amnica*), denotes an isle or fenny ground, according to Bede, or a river island. And where any place is called by that name, and this syllable is joined with any other in the names of places, it signifies a place surrounded with water, as the Flatholmes and Stepholmes in the Severn near Bristol; but if the situation of the place is not near the water, it may then signify a hilly place; *holm* in Saxon signifying also "a hill or cliff."

HOLocaust (formed from *ὅλος*, "whole", and *καίω*, "I consume with fire"), a kind of sacrifice, wherein the whole offering is burnt or consumed by fire, as an acknowledgment that God, the creator, preserver, and lord of all, was worthy of all honour and worship, and as a token of men's giving themselves entirely up to him. It is called also in Scripture a *burnt-offering*. Sacrifices of this sort are often mentioned by the heathens as well as Jews; particularly by Xenophon, *Cyroped.* lib. viii. p. 446. *ed. Hutchins.* 1738, who speaks of sacrificing holocausts of oxen to Jupiter, and of horses to the sun; and they appear to have been in use long before the institution of the other Jewish sacrifices, by the law of Moses; (see Job. i. 5. xli. 8. and Gen. viii. 20. xxii. 13.). On this account, the Jews, who would not allow the Gentiles to offer on their altar any other sacrifices peculiarly enjoined by the law of Moses, admitted them by the Jewish priests to offer holocausts; because these were a sort of sacrifices prior to the law, and common to all nations. **Du-
ring**

Hollar.
H
Holocaust.

Holocaust, Holofernes. ring their subjection to the Romans, it was no uncommon thing for those Gentiles to offer sacrifices to the God of Israel at Jerusalem. Holocausts were deemed by the Jews the most excellent of all their sacrifices. It is said that this kind of sacrifice was in common use among the heathens, till Prometheus introduced the custom of burning only a part, and reserving the remainder for his own use. See SACRIFICE.

HOLOFERNES, lieutenant general of the armies of Nabuchodonosor king of Assyria, who having in a remarkable encounter overcome Arphaxad king of the Medes, sent to all the neighbouring nations with an intention of obliging them this way to submit to his empire, pretending that there could be no power capable of resisting him. At the same time Holofernes, at the head of a powerful army, passed the Euphrates, entered Cilicia and Syria, and subdued almost all the people of these provinces.

Being resolved to make a conquest of Egypt, he advanced towards Judæa, little expecting to meet with any resistance from the Jews. In the mean time, he was informed that they were preparing to oppose him; and Achior the commander of the Ammonites, who had already submitted to Holofernes, and was with some auxiliary troops in his army, represented to him that the Hebrews were a people protected in a particular manner by God Almighty, so long as they were obedient to him; and therefore he should not flatter himself with expectations of overcoming them, unless they had committed some offence against God, whereby they might become unworthy of his protection. Holofernes, disregarding this discourse, commanded Achior to be conveyed within sight of the walls of Bethulia, and tied to a tree, and left there, whither the Jews came and loosed him.

In the mean time Holofernes formed the siege of Bethulia; and having cut off the water which supplied the city, and set guards at the only fountain which the besieged had near the walls, the inhabitants were soon reduced to extremity, and resolved to surrender if God did not send them succours in five days. Judith, being informed of their resolution, conceived the design of killing Holofernes in his camp. She took her finest clothes, and went out of Bethulia with her maid-servant; and being brought to the general, she pretended that she could no longer endure the sins and excesses of the Jews, and that God had inspired her with the design of surrendering herself to him. As soon as Holofernes saw her, he was taken with her beauty; and some days after invited her to a great feast, which he prepared for the principal officers of his army. But he drank so much wine, that sleep and drunkenness hindered him from satisfying his passion. Judith, who in the night was left alone in his tent, cut off his head with his own sword; and departing with her servant from the camp, she returned to Bethulia with the head of Holofernes. As soon as it was day, the besieged made a sally upon their enemies, who going into their general's tent, found his headless carcass wallowing in its own blood. They then discerned that Judith had deceived them, and fled with precipitation, leaving the camp abounding with rich spoils; the Jews pursued them, killed a great number of them, and returned loaded with booty.

There is a great diversity of opinions concerning the

time when this war between Holofernes and the Jews happened. Some date it from the captivity of Babylon, in the reign of Manasseh, and pontificate of Eliakim the high-priest; others place it at some time after the captivity; and some doubt the truth of the whole transaction. See the article JUDITH.

HOLOGRAPHUM (composed of *ολος*, "all," and *γραφω*, "I write"), in the civil law, something written wholly in the hand-writing of the person who signs it. The word is chiefly used in speaking of a testament written wholly in the testator's own hand.

The Romans did not approve of holographic testaments; and, though Valentinian authorised them by a novel, they are not used where the civil law is in full force.

HOLOSTEUM, a genus of plants belonging to the triandria class; and in the natural method ranking under the 22d order, *Caryophyllei*. See BOTANY *Index*.

HOLOTHURIA, a genus of the order *vermes*, belonging to the class mollusca. See HELMINTHOLOGY *Index*.

HOLSTEIN, a duchy of Germany, bounded by the German ocean on the west; the Baltic, or the gulf of Lubeck, on the east; the duchy of Mecklenburg on the south-east; that of Bremen, with the river Elbe, on the south-west, and Lauenburg, with the territory of Hamburg, on the south. Its greatest length is about 80 miles, and its breadth 60. The diocese of Eutin, and the county of Ranzau, though they make a part of the duchy of Holstein, yet being lands belonging to the empire and circle, shall be described separately.

A great part of this country consists of rich marsh land, which being much exposed to inundations both from the sea and rivers, dikes have been raised at a great expence to guard and defend them. The pastures in the marshes are so rich, that cattle are bred in vast numbers and fattened in them, and great quantities of excellent butter and cheese made of their milk. They are also very fruitful in wheat, barley, pease, beans, and rape-seed. In the more barren, sandy, and heathy parts of the country, large flocks of sheep are bred and fed: nor are orchards wanting, or woods, especially of oak and beech; nor turf, poultry, game, and wild-fowl. Here is a variety both of sea and river fish; and the beef, veal, mutton, and lamb, are very fat and palatable. Holstein is also noted for beautiful horses. The gentry usually farm the cows upon their estates to a Hollander, as he is called, who for every cow pays from six to ten rix-dollars; the owner providing pasture for them in summer, and straw and hay in winter. It is no uncommon thing here to drain the ponds and lakes ones in three or four years, and sell the carp, lampreys, pikes, and perch, found in them; then sow them for several years after with oats, or use them for pasturage; and after that lay them under water again, and breed fish in them. There are hardly any hills in the country; but several rivers, of which the principal are the Eyder, the Stor, and the Trave. The duchy contains about 30 towns great and small; most part of the peasants are under villenage, being obliged to work daily for their lords, and not even at liberty to quit their estates. The nobility and the proprietors

Holstein. of manors are possessed of the civil and criminal jurisdiction, with other privileges and exemptions. Formerly there were diets, but now they seem to be entirely laid aside: meetings, however, of the nobility are still held at Kiel. The predominant religion here is Lutheranism, with superintendencies as in other Lutheran countries. In several places the Jews are allowed the exercise of their religion. At Gluckstadt and Altena are both Calvinist and Popish churches; and at Kiel a Greek Russian chapel. Besides the Latin schools in the towns, at Altena is a gymnasium, and at Kiel an university. Notwithstanding this country's advantageous situation for commerce, there are few manufactures and little trade in it. Hamburg and Lubeck supply the inhabitants with what they want from abroad; from whence and Altena they export some grain, malt, groats, starch, buck-wheat, pease, beans, rape-seed, butter, cheese, sheep, swine, horned cattle, horses, and fish. The manufactures of the duchy are chiefly carried on at Altena, Kiel, and Gluckstadt. The duchy of Holstein consists of the ancient provinces of Holstein, Stormar, Ditmarsh, and Wagria. It belongs partly to the king of Denmark, and partly to the dukes of Holstein Gottorf and Ploen. Anciently the counts of Holstein were vassals of the dukes of Saxony; but afterwards they received the investiture of their territories from the emperor, or the bishops of Lubeck in the emperor's name, though the investiture was afterwards given by the emperor in person. The king of Denmark appoints a regency over his part of Holstein and the duchy of Sleswick, which has its office at Gluckstadt. The seat of the great duke's privy council and regency-court, together with the chief consistory, which is united to it, is at Kiel: there are many inferior courts and consistories, from which an appeal lies to the higher. In the duchy of Holstein, the government of the convents and nobility is alternately in the king and duke for a year, from Michaelmas to Michaelmas. The person in whom the government is lodged administers it by his regency. In some cases an appeal lies from this court to the Aulic council or chamber at Wetzlar: the convents, the nobility, and the proprietors of manors in the country, have a civil and criminal jurisdiction over their estates. The revenues of the sovereign arise principally from their demesnes and regalia; besides which, there is a land and several other taxes and imposts. The king usually keeps here some regiments of foot and one of horse. The king, on account of his share in this country, styles himself *duke of Holstein, Stormar, and Ditmarsh*. The dukes both of the royal and princely houses style themselves *heirs of Norway, dukes of Sleswick, Holstein, Stormar, and Ditmarsh*, and counts of *Oldenburg and Delmenhorst*. In 1735, Duke Charles Frederic of Holstein Gottorf founded an order of knighthood here, viz. that of St Anne, the ensign of which is a red cross, enamelled, and worn pendant at a red ribbon edged with yellow.—The principal places of that part of the duchy belonging to the king of Denmark and the duke of Ploen are Gluckstadt, Itzehoe, Rendsburg, and Ploen; and that part belonging to the great duke are Kiel, Oldenburg, Preetz, and Altena.

The king of Denmark had originally a seat in the German diet, in consequence of possessing this duchy;

but he was deprived of this privilege when the Confederation of the Rhine was organized in 1806. In 1815, on the establishment of the new Germanic constitution, he was re-admitted into the diet; and was allowed for Holstein and Lauenburg three votes in the general assembly, and a place, the tenth in rank, at the ordinary diet. The population of Holstein, in 1818, amounted to 360,000. The Danish court has lately been endeavouring to make some improvements in the interior administration of the duchy.

HOLT, SIR JOHN, knight, eldest son of Sir Thomas Holt, serjeant-at-law, was born in 1642. He entered himself at Gray's Inn in 1658; and applied to the common law with so much industry, that he soon became a very eminent barrister. In the reign of James II. he was made recorder of London, which office he discharged with much applause for about a year and a half; but lost his place for refusing to expound the law suitably to the king's designs. On the arrival of the prince of Orange, he was chosen a member of the convention parliament, which afforded him a good opportunity of displaying his abilities; so that, as soon as the government was settled, he was made lord chief justice of the court of king's bench, and a privy counsellor. He continued chief justice for 22 years, with great repute for steadiness, integrity, and thorough knowledge in his profession. Upon great occasions he asserted the law with intrepidity, though he thereby ventured to incur by turns the indignation of both the houses of parliament. He published some reports, and died in 1709.

HOLT (Sax.) "a wood;" whereby the names of towns beginning or ending with *holt*, as *Buck-holt*, &c. denote that formerly there was great plenty of wood in those places.

HOLY. See **HOLINESS**.

HOLY-GHOST, one of the persons of the holy Trinity. See **TRINITY**.

Order of the Holy Ghost, the principal military order in France, instituted by Henry III. in 1569. It consists of 100 knights, who are to make proof of their nobility for three descents. The king is the grand-master or sovereign; and as such takes an oath on his coronation-day to maintain the dignity of the order.

The knights wear a golden cross, hung about their necks by a blue silk ribbon or collar. But before they receive the order of the Holy-Ghost, that of St Michael is conferred as a necessary degree; and for this reason their arms are surrounded with a double collar.

HOLYHEAD, a town and cape of the isle of Anglesea in Wales, and in the Irish channel, where people usually embark for Dublin, there being three packet-boats that sail for that city every Monday, Wednesday, and Friday, wind and weather permitting. It is 276 miles from London, and has a very convenient harbour for the northern trade, when taken short by contrary winds. It is situated near the extremity of the isle, and is joined to the north-west part of it by a stone bridge of one arch. It has a small market on Saturdays. The parish is about five or six miles long, and two or three broad, bounded nearly by the sea. The church stands above the harbour, within an old quadrangular fortification, with a bastion at each corner, built about 450. On a mountain near it is another old fortification called *Terris Monumentum*, which

Holstein
Holyhead.

Holyhead,
Holy-
Island.

which is an old stone wall without mortar, and in its centre is a small turret, and contains a well of water. Holyhead was frequently formerly visited by Irish rovers, and was defended as a place of consequence. There are several remains of old fortifications and Druidical antiquities in its neighbourhood, as well as chapels of religious worship. The parish church of Holyhead was built in the reign of Edward III. and is in the form of a cross, with a porch and steeple very antique. There was an old chapel near the church, now converted into a school-house. A salt-house was erected on an island in the harbour in Queen Anne's reign, but it is now in ruins. The town is little more than a fishing town, rendered considerable by being the place of passage to Ireland. It has three good inns. The passage hence to Ireland is in general about twelve hours. There is no fresh water here except from rain, nor any bread sold but what comes from Ireland. A bath and assembly-room were erected here in 1770. Under the mountains that overhang the town is a large cavern in the rock, supported by natural pillars, called the Parliament-house, accessible only by boats, and the tide runs into it. If this harbour was properly repaired, and ware-houses built, it would be very convenient for the Irish to import such of their goods as pay English duty, it being but a few hours sail from Dublin. Besides, the Dublin merchants might come over with the packets to see their goods landed. The commodities are, butter, cheese, bacon, wild-fowl, lobsters, crabs, oysters, razor-fish, shrimps, herrings, cod-fish, whittings, whiting-pollacks, cole-fish, sea-tenghes, turbot, soles, flounders, rays, and plenty of other fish. On the rocks the herb grows of which they make kelp, a fixed salt used in making glass, and in alum works. In the neighbourhood there is a large vein of white fullers earth and another of yellow, which might be useful to fullers. On the isle of Skerries, nine miles to the north, is a light-house, which may be seen 24 miles off. Large flocks of puffins are often seen here. Population 3005 in 1815.

HOLY-ISLAND, a small island lying on the coast of England, 10 miles south-east of Berwick, in Northumberland. Bede calls it a *semi-island*, being, as he observes, twice an island and twice continent in one day; for at the flowing of the tide, it is encompassed by water; and at the ebb, there is an almost dry passage, both for horses and carriages, to and from the main land; from which, if measured on a straight line, it is distant about two miles eastward; but on account of some quicksands passengers are obliged to make so many detours, that the length of way is nearly doubled. The water over these flats at spring-tides is only seven feet deep.—This island was by the Britons called *Inis Medicante*; also *Landisfarne*, from the small rivulet of Lindi or Landia, which here runs into the sea, and the Celtic word *fahren* or “recess;” and on account of its being the habitation of some of the first monks in this country, it afterwards obtained its present name of *Holy-island*. It measures from east to west about two miles and a quarter, and its breadth from north to south is scarcely a mile and a half. At the north-west part there runs out a spit of land of about a mile in length. The monastery is situated at the southernmost extremity; and at a small distance north of it stands the village. On this island there is plenty of fish and

fowl; but the air and soil are bad. There is not a tree on the island. The village, which stands on a rising ground, consists but of a few scattered houses, chiefly inhabited by fishermen; and it has two inns. The north and east coasts are formed of perpendicular rocks, the other sides sink by gradual slopes to the sands. There is a commodious harbour, defended by a block-house; which last was surprised and taken in 1715, but was soon invested and retaken.

Holy-island, though really part of Northumberland, belongs to Durham; and all civil disputes must be determined by the justices of that county.—It was a very ancient episcopal seat. Aidan the first bishop, after presiding in it 14 years, died and was buried here A. D. 651. Finan, his successor, built a wooden church, thatched with reeds, but before the end of the century covered with lead by Bishop Eadburt. St Cuthbert, who from a poor shepherd became monk of Melrose 15 years, was prior here 12 more, when he retired to one of the barren Farn rocks, from whence he was called to this see, which he held only two years, and returned to his retirement, where he died, and was buried at the east end of his oratory, where his stone coffin is still shown. His body was found fresh 11 years after his death. Lindisfarne was ruined by the Danes, A. D. 793, when the monks carried his body about for seven years, and at last settled at Chester-le-street, whither the see was translated, and where it continued many years. On a second destruction of the monastery by the Danes they were removing to Rippon, but stopped by a miracle at Durham, where the saint continued till the Reformation, when his body was found entire, and privately buried in a wooden coffin, as some pretend, near the clock, but more probably in the ground under where his shrine stood. The entrochi found among the rocks at Lindisfarne are called St Cuthbert's beads, and pretended to be made by him in the night. Eighteen bishops sat here till the removal of the see to Chester, which had eight more till the removal to Durham, A. D. 995. Lindisfarne became a cell to that Benedictine monastery, valued at 48l. per ann. The north and south walls of the church are standing, much inclined; part of the west end remains, but the east is down. The columns of the nave are of four different sorts, 12 feet high and 5 feet diameter, massy and richer than those of Durham; the bases and capitals plain, supporting circular arches. Over each arch are large windows in pairs, separated by a short column, and over these are smaller single windows. In the north and south walls are some pointed arches. The length of the body is 138 feet. breadth 18 feet, and with the two aisles 36 feet; but it may be doubted whether there ever was a transept. One arch of the centre tower remains adorned, as is its entrance from the nave, with Saxon zigzag. Somewhat to the east is the base of a cross, and to the west the present parish-church.

HOLY-Rood Day, a festival observed by the Roman Catholics, in memory of the exaltation of our Saviour's cross. See **CROSS** and **EXALTATION**.

HOLY-Well, a town of North Wales, in the county of Flint. It is a place of great note, for the well of St Winnifred, who was reputed a virgin martyr; and it is much frequented by people that come to bath in it, as well as by popish pilgrims out of devotion. The

Holy-
Island
Holy-well.

spring

Holy Well spring gushes forth with such impetuosity, that at a small distance it turns several mills. Over the spring is a chapel built upon pillars, and on the windows is painted the history of St Winnifred's life. There is a moss about the well, which some foolishly imagine to be St Winnifred's hair. W. Long. 3. 15. N. Lat. 54. 21.

HOMAGE, in *Law*, is the submission, loyalty, and service, which a tenant promised to his lord when he was first admitted to the land which he held of the lord in fee: also that owing to a king, or to any superior.

HOMBERG, **WILLIAM**, a celebrated physician, chemist, and philosopher, was the son of a Saxon gentleman, and born in Batavia, in the East Indies, in 1652. His father afterwards settling at Amsterdam, William there prosecuted his studies; and from thence removed to Jena, and afterwards to Leipsic, where he studied the law. In 1642, he was made advocate at Magdeburg, and there applied himself to the study of experimental philosophy. Some time after he travelled into Italy; and applied himself to the study of medicine, anatomy, and botany, at Padua. He afterwards studied at Bologna; and at Rome learned optics, painting, sculpture, and music. He at length travelled into France, England, and Holland; obtained the degree of doctor of physic at Wirtemberg; travelled into Germany and the North; visited the mines of Saxony, Bohemia, Hungary, and Sweden; and returned to France, where he acquired the esteem of the learned. He was on the point of returning into Germany, when M. Colbert being informed of his merit, made him such advantageous offers, as induced him to fix his residence at Paris. M. Homberg, who was already well known for his phosphorus, for a pneumatic machine of his own invention more perfect than that of Guericke, for his microscopes, for his discoveries in chemistry, and for the great number and variety of his curious observations, was received into the academy of sciences in 1691, and had the laboratory of that academy, of which he was one of the principal ornaments. The duke of Orleans, afterwards regent of the kingdom, at length made him his chemist, settled upon him a pension, gave him a most superb laboratory, and in 1704 made him his first physician. He had abjured the Protestant religion in 1682, and died in 1715. The memoirs of the academy of sciences, and other journals, contain many curious and learned disquisitions of this author. He had begun to give the elements of chemistry in the memoirs of the academy, and the rest were found among his papers fit for printing.

HOMBERG, a town of Germany, in the circle of the Upper Rhine, and landgravate of Hesse, seated ten miles north of Frankfurt, and gives title to one of the branches of the house of Hesse, who is its sovereign. E. Long. 8. 32. N. Lat. 50. 15.

HOMBERG, a town of France, in the department of Mont Tonnerre, and chief place of a canton, which contains above 4000 inhabitants. E. Long. 7. 21. N. Lat. 49. 11.

HOME, **HENRY**, Lord Kames, an eminent Scottish lawyer, and author of many celebrated works on various subjects, was descended of a very honourable and ancient family, and born in the year 1696.

VOL. X. Part II.

Lord Kames's grandfather, Henry Home, was a younger son of Sir John Home of Renton, who held the high office of lord justice-clerk, or chief criminal judge of Scotland, in the year 1663. He received the estate of Kames from his uncle George, brother to the then lord justice-clerk. The family of Renton is descended from that of the earls of Home, the representatives of the ancient princes of Northumberland, as appears from the records of the Lion Office.

The county of Berwick in Scotland has the honour of having given birth to this great and useful member of society. In early youth he was lively, and eager in the acquisition of knowledge. He never attended a public school; but was instructed in the ancient and modern languages, as well as in several branches of mathematics, and the arts necessarily connected with that science, by Mr Wingate, a man of considerable parts and learning, who spent many years as preceptor or private tutor to Mr Home.

After studying, with acuteness and diligence, at the university of Edinburgh, the civil law, and the municipal law of his own country, Mr Home early perceived that a knowledge of these alone is not sufficient to make an accomplished lawyer. An acquaintance with the forms and practical business of courts, and especially of the supreme court, as a member of which he was to seek for fame and emolument, he considered as essentially necessary to qualify him to be a complete barrister. He accordingly attended for some time the chamber of a writer to the signet, where he had an opportunity of learning the styles of legal deeds, and the modes of conducting different species of business. This wise step, independently of his great genius and unwearied application, procured him, after his admission to the bar, peculiar respect from the court, and proportional employment in his profession of an advocate. Whoever peruses the law-papers composed by Mr Home when a young man, will perceive an uncommon elegance of style, besides great ingenuity of reasoning, and a thorough knowledge of the law and constitution of his country. These qualifications, together with the strength and vivacity of his natural abilities, soon raised him to be an ornament to the Scottish bar; and, on the 2d day of February 1752, he was advanced to the bench as one of the judges of the court of session, under the title of *Lord Kames*.

Before this period, however, notwithstanding the unavoidable labours of his profession, Mr Home had favoured the world with several useful and ingenious works. In the year 1728, he published *Remarkable Decisions of the Court of Session from 1716 to 1728*, in one volume folio.—In 1732 appeared *Essays upon several subjects in law, viz. Jus tertii; Beneficium cendendum actionum; Vinco Vincendum; and Prescription*; in one volume 8vo. This first produce of his original genius, and of his extensive views, excited not only the attention, but the admiration of the judges, and of all the other members of the college of justice. This work was succeeded, in the year 1741, by *Decisions of the Court of Session from its first institution to the year 1740*, abridged and digested under proper heads, in a form of a Dictionary, in two volumes folio: a very laborious work, and of the greatest utility to every practical lawyer. In 1747 appeared *Essays*

4 D

Home. upon several subjects concerning British antiquities, viz. 1. Introduction of the feudal law into Scotland. 2. Constitution of parliament. 3. Honour, Dignity. 4. Succession, or Descent; with an appendix upon hereditary and indefeasible right, composed anno 1745, and published 1747, in one volume 8vo. In a preface to this work, Lord Kames informs us, that in the years 1745 and 1746, when the nation was in great suspense and distraction, he retired to the country; and in order to banish as much as possible the uneasiness of his mind, he contrived the plan, and executed this ingenious performance.

Though not in the order of time, we shall continue the list of all our author's writings on law, before we proceed to his productions on other subjects. In 1757, he published *The Statute Law of Scotland* abridged, with historical notes, in one volume 8vo; a most useful and laborious work. In the year 1759, he presented to the public a new work under the title of *Historical Law Tracts*, in one volume 8vo. It contains 14 interesting tracts, viz. *History of the Criminal Law*:—*History of Promises and Covenants*:—*History of Property*:—*History of Securities under and for Payment of Debt*:—*History of the Privilege which an Heir-apparent in a feudal holding has to continue the Possession of his Ancestor*.—*History of Regalities, and of the Privilege of pledging*:—*History of Courts*:—*History of Brieves*:—*History of Process in absence*:—*History of Execution against Moveables and Land for Payment of Debt*:—*History of Personal Execution for Payment of Debt*:—*History of Execution for obtaining Payment after the Death of the Debtor*:—*History of the limited and universal Representation of Heirs*:—*Old and New Extent*. In 1760, he published, in one volume folio, *The Principles of Equity*; a work which shows both the fertility of the author's genius and his indefatigable application. In 1766, he gave to the public another volume in folio of *Remarkable Decisions of the Court of Session*, from 1730 to 1752. In 1777, appeared his *Elucidations respecting the Common and Statute Law of Scotland*, in one volume 8vo. This book contains many curious and interesting remarks upon some intricate and dubious points which occur in the law of Scotland. In 1780, he published a volume in folio of *Select Decisions of the Court of Session* from 1752 to 1768.

From this sketch of Lord Kames's compositions and collections with a view to improve and elucidate the laws of Scotland, the reader may form some idea of his great industry, and of his anxious desire to promote the honour and welfare of his country. It remains to be remarked, that in the supreme court there, the law-writings of Lord Kames are held in equal estimation, and quoted with equal respect, as those of Coke or Blackstone in the courts of England.

Lord Kames's mind was very much inclined to metaphysical disquisitions. When a young man, in order to improve himself in his favourite study, he corresponded with the famous Berkeley bishop of Cloyne, Dr Butler bishop of Durham, Dr Samuel Clark, and many other ingenious and learned men both in Britain and Ireland. The letters of correspondence, we are happy to learn, have been carefully preserved by his son and heir George Home-Drummond, Esq. of Blair-Drummond.

Home. The year 1751 gave birth to the first fruits of his lordship's metaphysical studies, under the title of *Essays on the Principles of Morality and Natural Religion*, in two parts. Though a small volume, it was replete with ingenuity and acute reasoning, excited general attention, and gave rise to much controversy. It contained, in more explicit terms than perhaps any other work of a religious theist then known in Scotland, the doctrine which has of late made so much noise under the appellation of *philosophical necessity*. The same thing had indeed been taught by Hobbes, by Collins, and by the celebrated David Hume, Esq. but as those authors either were professed infidels, or were supposed to be such, it excited, as coming from them, no wonder, and provoked for a time very little indignation. But when a writer, who exhibited no symptoms of extravagant scepticism, who insinuated nothing against the truth of revelation in general, and who inculcated with earnestness the great duties of morality and natural religion, advanced at the same time so uncommon a doctrine as that of *necessity*; a number of pens were immediately drawn against him, and for a while the work and its author were extremely obnoxious to a great part of the Scottish nation. On the other hand, there were some, and those not totally illiterate, who, confounding *necessity* with *predestination*, complimented Mr Home on his masterly defence of the established faith: and though between these two schemes there is no sort of resemblance, except that the future happiness or misery of all men is, according to both, certainly foreknown and appointed by God; yet we remember, that a professor in a dissenting academy so far mistook the one for the other, that he recommended to his pupils the *Essays on Morality and Natural Religion*, as containing a complete vindication of the doctrine of Calvin. For this mistake he was dismissed from his office, and excluded from the communion of the sect to which he belonged. Lord Kames, like many other great and good men, continued a Necessarian to the day of his death; but in a subsequent edition of the *Essays*, he exhibited a remarkable proof of his candour and liberality of sentiment, by altering the expressions, which, contrary to his intention, had given such general offence.

In 1761, he published an *Introduction to the art of Thinking*, in one volume 12mo. This small but valuable book was originally intended for the instruction of his own family. The plan of it is both curious, amusing, and highly calculated to catch the attention and to improve the minds of youth. It consists of maxims collected from Rochefoucault and many other authors. To illustrate these maxims, and to rivet their spirit and meaning in the minds of young persons, his lordship has added to most of them beautiful stories, fables, and historical anecdotes.

In the department of belles lettres, his *Elements of Criticism* appeared in 1762, in three volumes 8vo. This valuable work is the first, and a most successful attempt to shew, that the art of criticism is founded on the principles of human nature. Such a plan, it might be thought, should have produced a dry and phlegmatic performance. Lord Kames, on the contrary, from the sprightliness of his manner of treating every subject he handled, has rendered the *Elements of Criticism* not only highly instructive, but one of the most entertaining books in our language. Before this work

work was published, Rollin's *Belles Lettres*, a dull performance, from which a student could derive little advantage, was universally recommended as a standard; but, after the Elements of Criticism were presented to the public, Rollin instantly vanished, and gave place to greater genius and greater utility. With regard to real instruction and genuine taste in composition of every kind, a student, a gentleman, or a scholar, can in no language find such a fertile field of information. Lord Kames, accordingly, had the happiness of seeing the good effects of his labours, and of enjoying for twenty years a reputation which he so justly merited.

A still farther proof of the genuine and various pursuits of this active mind was given in the year 1772, when his lordship published a work in one volume 8vo, under the title of *The Gentleman Farmer, being an attempt to improve Agriculture by subjecting it to the test of rational principles*. Our limits do not permit us to give details; but with regard to this book, we must inform the public, that all the intelligent farmers in Scotland uniformly declare, that, after perusing Young, Dickson, and a hundred other writers on agriculture, Lord Kames's *Gentleman Farmer* contains the best practical and rational information on the various articles of husbandry which can any where be obtained. As a practical farmer, Lord Kames has given many obvious proofs of his skill. After he succeeded in right of his lady, to the ample estate of Blair-Drummond in the county of Perth, he formed a plan for turning a large moss, consisting of at least 1500 acres, into arable land. His lordship had the pleasure, before he died, to see the plan successfully, though only partially executed. The same plan was afterwards carried on in a much more rapid manner by his son George Drummond, Esq. But as this is not a proper place for details of this nature, we must refer the reader to the article AGRICULTURE; where a particular account of this extraordinary, but extensively useful, operation is given.

In the year 1773, Lord Kames favoured the world with *Sketches of the History of Man*, in 2 vols 4to. This work consists of a great variety of facts and observations concerning the nature of man; the produce of much and profitable reading. In the course of his studies and reasonings, he amassed a vast collection of materials. These, when considerably advanced in years, he digested under proper heads, and submitted them to the consideration of the public. He intended that this book should be equally intelligible to women as to men; and, to accomplish this end, when he had occasion to quote ancient or foreign books, he uniformly translated the passages. The *Sketches* contain much useful information; and, like all his lordship's other performances, are lively and entertaining.

We now come to Lord Kames's last work, to which

he modestly gives the title of *Loose Hints upon Education, chiefly concerning the culture of the heart*. It was published in the year 1781, in one vol. 8vo, when the venerable and astonishing author was in the 85th year of his age. Though his lordship chose to call them *Loose Hints*, the intelligent reader will perceive in this composition an uncommon activity of mind at an age so far advanced beyond the usual period of human life, and an earnest desire to form the minds of youth to honour, to virtue, to industry, and to a veneration of the Deity.

Besides the books we have enumerated, Lord Kames published many temporary and fugitive pieces in different periodical works. In the *Essays Physical and Literary*, published by a society of gentlemen in Edinburgh, we find compositions of his lordship *On the Laws of Motion, On the Advantages of Shallow Ploughing*, and on *Evaporation*; all of which exhibit evident marks of genius and originality of thinking.

How a man employed through life in public business, and in business of the first importance, could find leisure for so many different pursuits, and excel in them (A), it is not easy for a meaner mind to form even a conception. Much, no doubt, is to be attributed to the superiority of his genius; but much must likewise have been the result of a proper distribution of his time. He rose early; when in the vigour of life at four o'clock, in old age at six; and studied all morning. When the court was sitting, the duties of his office employed him from eight or nine till twelve or one; after which, if the weather permitted, he walked for two hours with some literary friends, and then went home to dinner. Whilst he was on the bench, and we believe when he was at the bar, he neither gave nor accepted invitations to dinner during the *term* or *session*; and if any friend came uninvited to dinner with him, his lordship displayed his usual cheerfulness and hospitality, but always retired with his clerk as soon as he had drunk a very few glasses of wine, leaving his company to be entertained by his lady. The afternoon was spent as the morning had been, in study. In the evening he went to the theatre or the concert, from which he returned to the society of some men of learning, with whom he sat late, and displayed such talents for conversation as are not often found. It is observed by a late celebrated author, that "to read, write, and converse, in due proportions, is the business of a man of letters; and that he who hopes to look back hereafter with satisfaction upon past years, must learn to know the value of single minutes, and endeavour to let no particle of time fall useless to the ground." It was by practising these lessons that Lord Kames rose to literary eminence, in opposition to all the obstacles which the tumult of public business could place in his way.

To give a proper delineation of the public and private

(A) Upon reflecting on the studiousness of Lord Kames's disposition, and his numerous literary productions, the reader will naturally recal to his mind a striking similarity between his lordship and the laborious Pliny the Elder. In a letter from Pliny the Younger to Macer, the following passage occurs, which is equally applicable to both: *Nonne videtur tibi, recordanti quantum legerit, quantum scripserit, nec in officiis ullis, nec in amicitia principum fuisse?* which is thus translated by Melmoth: "When you reflect on the books he has read and the volumes he has written, are you not inclined to suspect, that he never was engaged in the affairs of the public, or the service of his prince?"

Home.

vate character of Lord Kames, would far exceed our limits. The writer of this article, however, who had the honour of an intimate acquaintance with this great and good man for more than twenty years, must be indulged in adding a few facts which fell under his own observation.

Lord Kames was remarkable for public spirit, to which he conjoined activity and great exertion. He for a long tract of time had the principal management of all the societies and boards for promoting the trade, fisheries, and manufactures, in Scotland. As conducive to those ends, he was a strenuous advocate for making and repairing turnpike roads through every part of the country. He had likewise a chief lead in the distribution and application of the funds arising from the estates in Scotland which had unfortunately been annexed to the crown. He was no less zealous in supporting, both by his writings and personal influence, literary associations. He was in some measure the parent of what was called the Physical and Literary Society. This society was afterwards incorporated into the *Royal Society of Edinburgh*, which received a charter from the crown, and which is daily producing marks of genius, as well as works of real utility.

As a private and domestic gentleman, Lord Kames was admired by both sexes. The vivacity of his wit, and of his animal spirits, even when advanced in years, rendered his company not only agreeable, but greatly solicited by the literati, and courted by ladies of the highest rank and accomplishments. He told very few stories; and rarely, if ever, repeated the same story to the same person. From the necessity of retailing anecdotes, the miserable refuge of those who, without genius, attempt to shine in conversation, the abundance of his own mind set him free; for his wit or his learning always suggested what the occasion required. He could with equal ease and readiness combat the opinions of a metaphysician, unravel the intricacies of law, talk with a farmer on improvements in agriculture, or estimate with a lady the merits of the dress in fashion. Instead of being jealous of rivals, the characteristic of little minds, Lord Kames suffered and encouraged every symptom of merit that he could discover in the scholar, or in the lowest mechanic. Before he succeeded to the estate of Blair Drummond, his fortune was small. Notwithstanding this circumstance, he, in conjunction with Mrs Drummond, his respectable and accomplished spouse, did much more service to the indigent than most families of greater opulence. If the present necessity was pressing, they gave money. They did more: When they discovered that male or female petitioners were capable of performing any art or labour, both parties exerted themselves in procuring that species of work which the poor people could perform. In cases of this kind, which were very frequent, the lady took charge of the women and his lordship of the men. From what has been said concerning the various and numerous productions of his genius, it is obvious that there could be few idle moments in his long protracted life. His mind was incessantly employed; either teeming with new ideas, or pursuing active and laborious occupations. At the same time, with all this intellectual ardour, one great feature in the character of Lord Kames, besides his literary talents and his

public spirit, was a remarkable innocency of mind. He not only never indulged in detraction, but when any species of scandal was exhibited in his company, he either remained silent, or endeavoured to give a different turn to the conversation. As natural consequences of this amiable disposition, he never meddled with politics, even when parties ran to indecent lengths in this country; and what is still more remarkable, he never wrote a sentence, notwithstanding his numerous publications, without a direct and a manifest intention to benefit his fellow creatures. In his temper he was naturally warm, though kind and affectionate. In the friendships he formed, he was ardent, zealous, and sincere. So far from being inclined to irreligion, as some ignorant bigots insinuated, few men possessed a more devout habit of thought. A constant sense of Deity, and a veneration for Providence, dwelt upon his mind. From this source arose that propensity which appears in all his writings, of investigating final causes, and tracing the wisdom of the Supreme Author of nature. But here we must stop. Lord Kames, to the great regret of the public, died on the 27th day of December 1782. As he had no marked disease but the debility necessarily resulting from extreme old age, a few days before his death he went to the Court of Session, addressed all the judges separately, told them he was speedily to depart, and took a solemn and an affectionate farewell.

HOME, *John*, a late eminent Scottish dramatic writer. See SUPPLEMENT.

HOMER, the prince of the Greek poets, flourished, according to Dr Blair, about 900 B. C. according to Dr Priestley 850, according to the Arundelian marbles 300, after the taking of Troy; and agreeable to them all about 400 years before Plato and Aristotle. Seven cities disputed the glory of having given him birth, viz. Smyrna, Rhodes, Colophon, Salamis, Chios, Argos, and Athens;

Smyrna, Rhodes, Colophon, Salamis, Chios, Argos, Athena; Orbis de patria certat, Homere, tua.

We have nothing that is very certain in relation to the particulars of his life. The most regular account is that which goes under the name of Herodotus; and though it is generally supposed to be a spurious piece, yet as it is ancient, was made use of by Strabo, and exhibits that idea which the later Greeks, and the Romans in the age of Augustus, entertained of Homer, we must content ourselves with giving an abstract of it.

A man of Magnesia, whose name was *Menalippus*, went to settle at Cumæ, where he married the daughter of a citizen called *Homyros*, and had by her a daughter called *Critheis*. The father and mother dying, the young woman was left under the tuition of Cleonax her father's friend, and suffering herself to be deluded, was got with child. The guardian, though his care had not prevented the misfortune, was however willing to conceal it; and therefore sent Critheis to Smyrna, which was then building, 18 years after the founding of Cumæ, and about 168 after the taking of Troy. Critheis being near her time, went one day to a festival which the town of Smyrna was celebrating on the banks of the river Meles; where her pains coming upon her, she was delivered of Homer, whom she called *Melissigenes*, because he was born on the banks

Home, Homer.

Homer.

banks of that river. Having nothing to maintain her, she was forced to spin, and a man of Smyrna called *Phemius*, who taught literature and music, having often seen *Critheis*, who lodged near him, and being pleased with her housewifery, took her into his house to spin the wool he received from his scholars for their schooling. Here she behaved herself so modestly and discreetly, that *Phemius* married her; and adopted her son, in whom he discovered a wonderful genius, and the best natural disposition in the world. After the death of *Phemius* and *Critheis*, *Homer* succeeded to his father-in-law's fortune and school; and was admired, not only by the inhabitants of *Smyrna*, but by strangers, who resorted from all parts to that place of trade. A shipmaster called *Mentes*, who was a man of learning and a lover of poetry, was so taken with *Homer*, that he persuaded him to leave his school, and to travel with him. *Homer*, who had then begun his poem of the *Iliad*, and thought it of great consequence to see the places he should have occasion to treat of, embraced the opportunity. He embarked with *Mentes*, and during their several voyages never failed carefully to note down all that he thought worth observing. He travelled into *Egypt*; from whence he brought into Greece the names of their gods, the chief ceremonies of their worship, and a more improved knowledge in the arts than what prevailed in his own country. He visited *Africa* and *Spain*; in his return from whence he touched at *Ithaca*, where he was much troubled with a rheum falling upon his eyes. *Mentes* being in haste to take a turn to *Leucadia* his native country, left *Homer* well recommended to *Mentor*, one of the chief men of the island of *Ithaca*, who took all possible care of him. There *Homer* was informed of many things relating to *Ulysses*, which he afterwards made use of in composing his *Odyssey*. *Mentes* returning to *Ithaca*, found *Homer* cured. They embarked together; and after much time spent in visiting the coasts of *Peloponnesus* and the islands, they arrived at *Colophon*, where *Homer* was again troubled with the distaxion upon his eyes, which proved so violent, that he is said to have lost his sight. This misfortune made him resolve to return to *Smyrna*, where he finished his *Iliad*. Some time after, the ill posture of his affairs obliged him to go to *Cumæ*, where he hoped to have found some relief. Here his poems were highly applauded: but when he proposed to immortalize their town, if they would allow him a salary, he was answered, that "there would be no end of maintaining all the *Opuses*, or blind men;" and hence got the name of *Homer*. He afterwards wandered through several places, and stopped at *Chios*, where he married, and composed his *Odyssey*. Some time after, having added many verses to his poems in praise of the cities of Greece, especially of *Athens* and *Arges*, he went to *Samos*, where he spent the winter, singing at the houses of the great men, with a train of boys after him. From *Samos* he went to *Io*, one of the *Sporades*, with a design to continue his voyage to *Athens*; but landing by the way at *Chios*, he fell sick, died, and was buried on the sea shore.

The only incontestable works which *Homer* has left behind him are the *Iliad* and *Odyssey*. The *Batrachomyomachia*, or battle of the frogs and mice, has been disputed. The hymns have been disputed also, and at-

tributed by the scholiasts to *Cynethus* the rhapsodist: but neither *Thucydides*, *Lucian*, nor *Pausanias*, have scrupled to cite them as genuine. Many other pieces are ascribed to him: epigrams, the *Eastipes*, the *Ceropes*, the destruction of *Oschalia*, of which only the names are remaining.

Nothing was ever comparable to the clearness and majesty of *Homer's* style; to the sublimity of his thoughts; to the strength and sweetness of his verses. All his images are striking; his descriptions just and exact; the passions so well expressed, and nature so justly and finely painted, that he gives to every thing motion, life, and action. But he more particularly excels in invention, and in the different characters of his heroes, which are so varied, that they affect us in an inexpressible manner. In a word, the more he is read by a person of good taste, the more he is admired. Nor are his works to be esteemed merely as entertaining poems, or as the monuments of a sublime and varied genius. He was in general so accurate with respect to costume, that he seldom mentioned persons or things that we may not conclude to have been known during the times of which he writes; and it was *Mr Pope's* opinion, that his account of people, princes, and countries, was purely historical, founded on the real transactions of those times, and by far the most valuable piece of history and geography left us concerning the state of Greece in that early period. His geographical divisions of that country were thought so exact, that we are told of many controversies concerning the boundaries of Grecian cities which have been decided upon the authority of his poems.

Alcibiades gave a rhetorician a box on the ear for not having *Homer's* writings in his school. *Alexander* was ravished with them, and commonly placed them under his pillow with his sword: he inclosed the *Iliad* in the precious casket that belonged to *Darius*; "in order (said he to his courtiers) that the most perfect production of the human mind might be inclosed in the most valuable casket in the world." And one day seeing the tomb of *Achilles* in *Sigea*, "Fortunate hero! (cried he), thou hast had a *Homer* to sing thy victories!" *Lycurgus*, *Solon*, and the kings and princes of Greece, set such a value on *Homer's* works, that they took the utmost pains in procuring correct editions of them, the most esteemed of which is that of *Aristarchus*. *Didymus* was the first who wrote notes on *Homer*; and *Eustathius*, archbishop of *Thessalonica*, in the 12th century, is the most celebrated of his commentators. *Mr Pope* has given an elegant translation of the *Iliad*, adorned with the harmony of poetic numbers; and *Mad. Dacier* has translated both the *Iliad* and *Odyssey* in prose.

Those who desire to know the several editions of *Homer*, and the writers who have employed themselves on the works of that great poet, may consult *Fabricius*, in the first volume of his *Bibliotheca Græca*.

A very singular discovery, however, which was made a few years ago in *Russia*, deserves to be here mentioned, together with the circumstances that attended it. *Christian Frederic Matthæi*, who had been educated by the learned *Ernesti*, and did credit to the instructions of that celebrated master by the great erudition that he displayed, being invited to settle at *Moscow*, and to assist in a plan of literature for which his abilities and ac-

Homer.

Homer.

quisitions eminently qualified him; on his arrival at that city was informed, equally to his astonishment and satisfaction, that a very copious treasure of Greek manuscripts was deposited in the library of the Holy Synod, which no person in that country had either the abilities to make use of, or the curiosity to examine. Struck with the relation of a circumstance so unexpected, and at the same time so peculiarly agreeable to his classical taste, he immediately seized the opportunity that was fortunately offered him, to explore this repository of hidden treasure. After having examined several curious books, he discovered a manuscript copy of the works of Homer, written about the conclusion of the 14th century, but evidently a transcript from a very ancient and most valuable copy, which, besides the *Iliad* and the *Odyssey*, contains also 16 of the hymns, which have been long published under the name of *Homer*. Nor was this all. Twelve lines of a lost hymn to *Bacchus*, and the hymn to *Ceres*, which was also lost, were preserved in this curious and long unnoticed manuscript. The hymn to *Ceres* appears to be entire, excepting a few lines towards the close: and it is surely remarkable, that a Greek poem, attributed to *Homer*, which had been lost for ages, should be at length discovered in *Muscovy*, the rudest and most unclassical country in *Europe*. *M. Matthæi*, exulting in an acquisition so unexpected, and at the same time so valuable, communicated it, with singular disinterestedness, to his learned friend *M. Ruhnkenius*, with whose talents and extraordinary erudition he was well acquainted, that this gentleman might present it to the world without those delays which would probably have retarded the publication of it at *Moscow*. He was rather induced to employ *M. Ruhnkenius* in the publication of this curious and beautiful remnant of antiquity, because he knew that this gentleman had been particularly engaged in the study of the hymns of *Homer*, in order to give the public a complete edition of them. The hymn to *Ceres*, and the fragment of the hymn to *Bacchus*, were printed in 1780 at *Leyden*, under the care of *M. Ruhnkenius*, who has added some very valuable notes and observations on the hymn to *Ceres*, which tend to illustrate its beauties, and to throw a light on some of its obscurities. The learned editor observes, that nothing was more distant from his expectations than the discovery of this hymn to *Ceres*. He knew indeed that a poem bearing that title, and ascribed to *Homer*, existed in the second century; but as it had long been considered as irretrievably lost, he had formed no hopes of ever seeing it rescued from the obscurity to which it had been consigned. He acknowledges, that he has many doubts with respect to the high and illustrious origin ascribed to this hymn: but as no positive external evidence can be produced to determine the point, he chooses to rest his argument on what appears to him the more certain ground of internal proof; and observes, that though the poem be exquisitely beautiful, yet that it is evidently deficient in some of *Homer's* more striking and predominant characteristics. It wants his energy and spirit; that vigour, that inspiration, which animate and give an irresistible power, as well as an enchanting beauty, to the poems of that sublime and inimitable bard. This opinion, as we have already seen, hath been given by other critics of all the hymns of

Homer. But though *M. Ruhnkenius* is not inclined to attribute to *Homer* the hymn to *Ceres*, he yet acknowledges, that the structure of its language is founded on the model of that great poet, and he hesitates not to give it the honour of very high antiquity. He is of opinion, that it was written immediately after *Homer*, or at least in the age of *Hesiod*; and he congratulates the age on the discovery of so curious a poem, rescued by mere accident from the darkest retreats of oblivion, and perhaps but at a slight distance from inevitable perdition. He deems it to be an acquisition, not only calculated to gratify the curiosity of the connoisseurs in classic antiquity, or to entertain those lovers of Greek poetry whose studies are made subservient to a refined and elegant species of amusement, but he also esteems it to be of particular use to the critic, as it tends to illustrate some obscure passages both in the Greek and Latin poets.

HOMER, Omer, or Chomer, a Jewish measure, containing the tenth part of the epha. See **CORUS** and **MEASURE**.

HOMESOKEN. See **HAMESECKEN**.

HOMICIDE, signifies in general the taking away of any person's life. It is of three kinds; *justifiable*, *excusable*, and *felonious*. The first has no share of guilt at all; the second very little; but the third is the highest crime against the law of nature that man is capable of committing.

I. Justifiable homicide is of divers kinds.

1. Such as is owing to some unavoidable necessity, without any will, intention, or desire, and without any inadvertence or negligence, in the party killing, and therefore without any shadow of blame; as, for instance, by virtue of such an office as obliges one, in the execution of public justice, to put a malefactor to death, who hath forfeited his life by the laws and verdict of his country. This is an act of necessity, and even of civil duty; and therefore not only justifiable but commendable, where the law requires it. But the law must require it, otherwise it is not justifiable: therefore wantonly to kill the greatest of malefactors, a felon, or a traitor, attainted or outlawed, deliberately, uncompelled, and extrajudicially, is murder. And farther, if judgment of death be given by a judge not authorized by lawful commission, and execution is done accordingly, the judge is guilty of murder. Also such judgment, when legal, must be executed by the proper officer, or his appointed deputy; for no one else is required by law to do it, which requisition it is that justifies the homicide. If another person doth it of his own head, it is held to be murder: even though it be the judge himself. It must farther be executed, *servato juris ordine*; it must pursue the sentence of the court. If an officer beheads one who is adjudged to be hanged, or *vice versa*, it is murder: for he is merely ministerial, and therefore only justified when he acts under the authority and compulsion of the law. But if a sheriff changes one kind of punishment for another; he then acts by his own authority, which extends not to the commission of homicide; and besides, this licence might occasion a very gross abuse of his power. The king indeed may remit part of a sentence, as in the case of treason, all but the beheading: but this is no change, no introduction of a new punishment; and in the case of felony,

Homer

Homicide

Homicide. felony, where the judgment is *to be hanged*; the king (it hath been said) cannot legally order even a peer to be beheaded.

Again: In some cases homicide is justifiable, rather by the *permission*, than by the absolute *command*, of the law: either for the *advancement* of public *justice*, which without such indemnification would never be carried on with proper vigour; or, in such instances where it is committed for the *prevention* of some atrocious *crime*, which cannot otherwise be avoided.

2. Homicides, committed for the *advancement* of public *justice*, are, 1. Where an officer, in the execution of his office, either in a civil or criminal case, kills a person that assaults and resists him. 2. If an officer, or any private person, attempts to take a man charged with felony, and is resisted; and, in the endeavour to take him, kills him. 3. In case of a riot, or rebellious assembly, the officers endeavouring to disperse the mob are justifiable in killing them, both at common law, and by the riot act, 1 Geo. I. c. 5. 4. Where the prisoners in a gaol, or going to gaol, assault the gaoler or officer, and he in his defence kills any of them, it is justifiable, for the sake of preventing an escape. 5. If trespassers in forests, parks, chases, or warrens, will not surrender themselves to the keepers, they may be slain; by virtue of the statute 21 Edward I. stat. 2. *de malefactoribus in parcis*, and 3 and 4 W. and M. c. 10. But, in all these cases, there must be an apparent necessity on the officer's side; viz. that the party could not be arrested or apprehended, the riot could not be suppressed, the prisoners could not be kept in hold, the deer-stealers could not but escape, unless such homicide were committed: otherwise, without such absolute necessity, it is not justifiable. 6. If the champions in a trial by battle killed either of them the other, such homicide was justifiable, and was imputed to the just judgment of God, who was thereby presumed to have decided in favour of the truth.

3. In the next place, such homicide as is committed for the *prevention* of any forcible and atrocious *crime*, is justifiable by the law of nature; and also by the law of England, as it stood so early as the time of Bracton, and as it is since declared by stat. 24 Hen. VIII. c. 5. If any person attempts a robbery or murder of another, or attempts to break open a house in the *night-time* (which extends also to an attempt to burn it), and shall be killed in such attempt, the slayer shall be acquitted and discharged. This reaches not to any crime unaccompanied with force, as picking of pockets; or to the breaking open of any house in the *day-time*, unless it carries with it an attempt of robbery also. So the Jewish law, which punished no theft with death, makes homicide only justifiable in case of *nocturnal* house-breaking: "if a thief be found breaking up, and he be smitten that he die, no blood shall be shed for him:" but if the sun be risen upon him, there shall blood be shed for him; for he should have made full restitution. At Athens, if any theft was committed by night, it was lawful to kill the criminal, if taken in the fact: and, by the Roman law of the twelve tables, a thief might be killed by night with impunity; or even by day, if he armed himself with any dangerous weapon: which amounts very nearly to the same as is permitted by our own constitutions.

The Roman law also justifies homicide, when com-

mitted in defence of the chastity either of one's self or relations: and so also, according to Selden, stood the law in the Jewish republic. The English law likewise justifies a woman killing one who attempts to ravish her: and so too the husband or father may justify killing a man, who attempts a rape upon his wife or daughter; but not if he takes them in adultery by consent; for the one is forcible and felonious, but not the other. And there is no doubt but the forcibly attempting a crime, of a still more detestable nature, may be equally resisted by the death of the unnatural aggressor. For the one uniform principle that runs through our own, and all other laws, seems to be this: That where a crime, in itself capital, is endeavoured to be committed by force, it is lawful to repel that force by the death of the party attempting. But, we must not carry this doctrine to the same visionary length that Mr Locke does; who holds, "that all manner of force without right upon a man's person, puts him in a state of war with the aggressor; and, of consequence, that, being in such a state of war, he may lawfully kill him that puts him under this unnatural restraint." However just this conclusion may be in a state of uncivilized nature, yet the law of England, like that of every other well-regulated community, is too tender of the public peace, too careful of the lives of the subjects, to adopt so contentious a system; nor will suffer with impunity any crime to be *prevented* by death, unless the same, if committed, would also be *punished* by death.

In these instances of *justifiable* homicide, it may be observed, that the slayer is in no kind of fault whatsoever; not even in the minutest degree; and is therefore to be totally acquitted and discharged, with commendation rather than blame. But that is not quite the case in *excusable* homicide, the very name whereof imports some fault, some error, or omission; so trivial, however, that the law excuses it from the guilt of felony, though in strictness it judges it deserving of some little degree of punishment.

II. Excusable homicide is of two sorts; either *per infortunium*, by misadventure; or *se defendendo*, upon a principle of self-preservation. We will first see wherein these two species of homicide are distinct, and then wherein they agree.

1. Homicide *per infortunium*, or misadventure, is where a man, doing a lawful act, without any intention of hurt, unfortunately kills another; as where a man is at work with a hatchet, and the head thereof flies off and kills a stander-by; or where a person, qualified to keep a gun, is shooting at a mark, and undesignedly kills a man: for the act is lawful, and the effect is merely accidental. So where a parent is moderately correcting his child, a master his apprentice or scholar, or an officer punishing a criminal, and happens to occasion his death, it is only misadventure; for the act of correction was lawful: but if he exceeds the bounds of moderation, either in the manner, the instrument, or the quantity of punishment, and death ensues, it is manslaughter at least, and in some cases (according to the circumstances) murder; for the act of immoderate correction is unlawful. Thus by an edict of the emperor Constantine, when the rigour of the Roman law with regard to slaves began to relax and soften, a master was allowed to chastise his slave with rods and imprisonment,

Homicide. imprisonment, and if death accidentally ensued, he was guilty of no crime; but if he struck him with a club or a stone, and thereby occasioned his death, or if in any other yet grosser manner *immoderatè suo jure utatur, tunc reus homicidii sit.*

But to proceed. A tilt or tournament, the martial diversion of our ancestors, was however an unlawful act; and so are boxing and sword-playing, the succeeding amusement of their posterity: and therefore, if a knight in the former case, or a gladiator in the latter, be killed, such killing is felony of manslaughter. But if the king command or permit such diversion, it is said to be only misadventure; for then the act is lawful: In like manner as, by the laws both of Athens and Rome, he who killed another in the *pancratium*, or public games, authorised or permitted by the state, was not held to be guilty of homicide. Likewise to whip another's horse, whereby he runs over a child and kills him, is held to be accidental in the rider, for he has done nothing unlawful; but manslaughter in the person who whipped him, for the act was a trespass, and at best a piece of idleness, of inevitably dangerous consequence. And in general, if death ensues in consequence of an idle, dangerous, and unlawful sport, as shooting or casting stones in a town, or the barbarous diversion of cock-throwing; in these and similar cases, the slayer is guilty of manslaughter, and not misadventure only; for these are unlawful acts.

2. Homicide in *self-defence*, or *se defendendo*, upon a sudden affray, is also excusable rather than justifiable, by the English law. This species of self-defence must be distinguished from that just now mentioned, as calculated to hinder the perpetration of a capital crime; which is not only a matter of excuse, but of justification. But the self-defence which we are now speaking of, is that whereby a man may protect himself from an assault, or the like, in the course of a sudden brawl or quarrel, by killing him who assaults him. And this is what the law expresses by the word *chance-medley*, or (as some rather choose to write it) *chaud-medley*; the former of which in its etymology signifies a *casual* affray, the latter an affray in the *heat* of blood or passion: both of them of pretty much the same import; but the former is in common speech too often erroneously applied to any manner of homicide by misadventure; whereas it appears by the statute 24 Hen. VIII. c. 5. and our ancient books, that it is properly applied to such killing as happens in self-defence upon a sudden rencounter. The right of natural defence does not imply a right of attacking: for, instead of attacking one another for injuries past or impending, men need only have recourse to the proper tribunals of justice. They cannot therefore legally exercise this right of preventive defence, but in sudden and violent cases; when certain and immediate suffering would be the consequence of waiting for the assistance of the law. Wherefore, to excuse homicide by the plea of self-defence, it must appear that the slayer had no other possible means of escaping from his assailant.

In some cases this species of homicide (upon *chance-medley* in self-defence) differs but little from manslaughter, which also happens frequently upon *chance-medley* in the proper legal sense of the word. But the true criterion between them seems to be this; when both parties are actually combating at the time when the

Homicide. mortal stroke is given, the slayer is then guilty of manslaughter; but if the slayer hath not begun to fight, or (having begun) endeavours to decline any farther struggle, and afterwards, being closely pressed by his antagonist, kills him to avoid his own destruction, this is homicide excusable by self-defence. For which reason the law requires, that the person, who kills another in his own defence, should have retreated as far as he conveniently or safely can, to avoid the violence of the assault, before he turns upon his assailant; and that not fictitiously, or in order to watch his opportunity, but from a real tenderness of shedding his brother's blood. And though it may be cowardice in time of war between two independent nations, to flee from an enemy; yet between two fellow subjects, the law countenances no such point of honour: because the king and his courts are the *vindices injuriarum*, and will give to the party wronged all the satisfaction he deserves. In this the civil law also agrees with ours, or perhaps goes rather farther; "*qui cum aliter tueri se non possunt, damni culpam dederint, innocui sunt.*" The party assaulted must therefore flee as far as he conveniently can, either by reason of some wall, ditch, or other impediment; or as far as the fierceness of the assault will permit him; for it may be so fierce as not to permit him to yield a step, without manifest danger of his life, or enormous bodily harm; and then in his defence he may kill his assailant instantly. And this is the doctrine of universal justice, as well as of the municipal law.

And, as the *manner* of the defence, so is also the *time* to be considered: for if the person assaulted does not fall upon the aggressor till the affray is over, or when he is running away, this is revenge, and not defence. Neither, under the colour of self-defence, will the law permit a man to screen himself from the guilt of deliberate murder: for if two persons, A and B, agree to fight a duel, and A gives the first onset, and B retreats as far as he safely can, and then kills A, this is murder; because of the previous malice and concerted design. But if A upon a sudden quarrel assaults B first, and, upon B's returning the assault, A really and *bona fide* flies; and, being driven to the wall, turns again upon B and kills him; this may be *se defendendo*, according to some of our writers; though others have thought this opinion too favourable: inasmuch as the necessity, to which he is at last reduced, originally arose from his own fault. Under this excuse of self-defence, the principal civil and natural relations are comprehended: therefore, master and servant, parent and child, husband and wife, killing an assailant in the necessary defence of each other respectively, are excused; the act of the relation assisting being construed the same as the act of the party himself.

There is one species of homicide *se defendendo*, where the party slain is equally innocent as he who occasions his death: and yet this homicide is also excusable from the great universal principle of self-preservation, which prompts every man to save his own life preferable to that of another, where one of them must inevitably perish. As, among others, in that case mentioned by Lord Bacon, where two persons, being shipwrecked, and getting on the same plank, but finding it not able to save them both, one of them thrusts the other from

Homicide. it, whereby he is drowned. He who thus preserves his own life at the expence of another man's, is excusable through unavoidable necessity, and the principle of self-defence; since their both remaining on the same weak plank is a mutual though innocent attempt upon, and an endangering of, each other's life.

Let us next take a view of those circumstances wherein these two species of homicide, by misadventure and self-defence, agree; and these are in their blame and punishment. For the law sets so high a value upon the life of a man; that it always intends some misbehaviour in the person who takes it away, unless by the command or express permission of the law. In the case of misadventure, it presumes negligence, or at least a want of sufficient caution, in him who was so unfortunate as to commit it; who therefore is not altogether faultless. And as to the necessity which excuses a man who kills another *se defendendo*, Lord Bacon intitles it *necessitas culpabilis*, and thereby distinguishes it from the former necessity of killing a thief or a malefactor. For the law intends that the quarrel or assault arose from some unknown wrong, or some provocation, either in word or deed: and since in quarrels both parties may be, and usually are, in some fault; and as it scarce can be tried who was originally in the wrong, the law will not hold the survivor entirely guiltless. But it is clear, in the other case, that where I kill a thief who breaks into my house, the original default can never be upon my side. The law besides may have a farther view, to make the crime of homicide more odious, and to caution men how they venture to kill another upon their own private judgment, by ordaining, that he who slays his neighbour, without an express warrant from the law so to do, shall in no case be absolutely free from guilt.

Nor is the law of England singular in this respect. Even the slaughter of enemies required a solemn purification among the Jews; which implies, that the death of a man, however it happens, will leave some stain behind it. And the Mosaical law appointed certain cities of refuge for him "who killed his neighbour unawares; as if a man goeth into the wood with his neighbour to hew wood, and his hand fetcheth a stroke with the ax to cut down a tree, and the head slippeth from the helve, and lighteth upon his neighbour that he die, he shall flee into one of those cities and live." But it seems he was not held wholly blameless, any more than in the English law; since the avenger of blood might slay him before he reached his asylum, or if he afterwards stirred out of it till the death of the high priest. In the imperial law likewise casual homicide was excused, by the indulgence of the emperor signed with his own sign manual, *adnotatione principis*; otherwise, the death of a man, however committed, was in some degree punishable. Among the Greeks, homicide by misfortune was expiated by voluntary banishment for a year. In Saxony, a fine is paid to the kindred of the slain; which also, among the western Goths, was little inferior to that of voluntary homicide: and in France, no person is ever absolved in cases of this nature, without a largess to the poor, and the charge of certain masses for the soul of the party killed.

The penalty inflicted by our laws is said by Sir Edward Coke to have been anciently no less than death;
VOL. X. Part II. †

which, however, is with reason denied by later and more accurate writers. It seems rather to have consisted in a forfeiture, some say of all the goods and chattels, others of only a part of them, by way of fine or *weregild*: which was probably disposed of, as in France, *in pios usus*, according to the humane superstition of the times, for the benefit of *his* soul who was thus suddenly sent to his account with all his imperfections on his head: But that reason having long ceased, and the penalty (especially if a total forfeiture) growing more severe than was intended, in proportion as personal property has become more considerable, the delinquent has now, and has had as early as our records will reach, a pardon and writ of restitution of his goods as a matter of course and right, only paying for suing out the same. And, indeed, to prevent this expence, in cases where the death has notoriously happened by misadventure or in self-defence, the judges will usually permit (if not direct) a general verdict of acquittal.

III. Felonious homicide is an act of a very different nature from the former, being the killing of a human creature, of any age or sex, without justification or excuse. This may be done either by killing one's self, or another man: for the consideration of which, see the articles *SELF-Murder*, *MURDER*, and *MANSLAUGHTER*.

HOMILY, in ecclesiastical writers, a sermon or discourse upon some point of religion, delivered in a plain manner, so as to be easily understood by the common people. The word is Greek, *ὁμιλία*; formed of *ὁμιλεω*, *coetus*, "assembly or council."

The Greek homily, says M. Fleury, signifies a familiar discourse, like the Latin *sermo*; and discourses delivered in the church took these denominations, to intimate, that they were not harangues or matters of ostentation and flourish, like those of profane orators, but familiar and useful discourses, as of a master to his disciples, or a father to his children.

All the homilies of the Greek and Latin fathers are composed by bishops. We have none of Tertullian, Clemens Alexandrinus, and many other learned persons; because, in the first ages, none but bishops were admitted to preach. The privilege was not ordinarily allowed to priests till toward the fifth century. St Chrysostom was the first presbyter that preached steadily. Origen and St Augustine also preached; but it was by a peculiar license or privilege.

Photius distinguishes *homily* from *sermon*; in that the homily was performed in a more familiar manner, the prelate interrogating and talking to the people, and they in their turn answering and interrogating him, so that it was properly a conversation; whereas the sermon was delivered with more form, and in the pulpit, after the manner of the orators.

The practice of compiling homilies, which were to be committed to memory, and recited by ignorant or indolent priests, commenced towards the close of the 8th century, when Charlemagne ordered Paul Deacon and Alcuin to form homilies or discourses upon the Gospels and Epistles, from the ancient doctors of the church. This gave rise to that famous collection intitled the *Homiliarium of Charlemagne*, and which being followed as a model by many productions of the same kind, composed by private persons, from a principle of

Homicide, Homily.

Homily
Honan. pious zeal, contributed much (says Mosheim) to nourish the indolence, and to perpetuate the ignorance of a worthless clergy.

There are still extant several fine homilies; composed by the ancient fathers, particularly St. Chrysostom and St. Gregory.

Clementine HOMILIES, in ecclesiastical history, are nineteen homilies in Greek, published by Cotelierus, with two letters prefixed; one of them written in the name of Peter, the other in the name of Clement; to James bishop of Jerusalem; in which last letter they are intitled Clement's Epitome of the Preaching and Travels of Peter. According to Le Clerc, these homilies were composed by an Ebionite in the second century; but Montfaucon supposes that they were forged long after the age of St. Athanasius. Dr. Lardner apprehends, that the Clementine homilies were the original or first edition of the Recognitions; and that they are the same with the work censured by Eusebius under the title of Dialogues of Peter and Apollonius.

HOMINE REPLEVIANDO, a writ for the bailing of a man out of prison when he is confined without commandment of the king or his judges, or for any cause that is repleviable. But this writ is now seldom used; a writ of *habeas corpus* being sued out on the necessary occasions.

HOMMOC, a name given by mariners to a hillock or small eminence of land, resembling the figure of a oone, and appearing on the sea coast of any country.

HOMO, MAN, is ranked by Linnæus under the order of primates; and characterised by having four parallel fore teeth both in the upper and lower jaw, and two mammæ on the breast. The species, according to this author, are two; viz. the homo sapiens, and the homo troglodytes.

He subdivides the homo sapiens into five varieties, viz. the American, the European, the Asiatic, the African, and what he calls the *monstrous*. See **MAN**.

The troglodytes, or orang-outang, is a native of Ethiopia, Java, and Amboina. His body is white; he walks erect, and is about one-half the ordinary human size. He generally lives about 25 years. He conceals himself in caves during the day, and searches for his prey in the night. He is said to be exceedingly sagacious, but is not endowed with the faculty of speech. See **TROGLODYTES** and **SIMIA**, **MAMMALIA** *Index*.

HOMOGENEOUS, or **HOMOGENEAL** (composed of the Greek *ὁμοιός*, "like," and *γενος*, "kind"), is a term applied to various subjects, to denote, that they consist of similar parts, or of parts of the same nature and kind; in contradistinction to *heterogeneous*, where the parts are of different natures, &c.

HOMOLOGATION, in the civil law, the act of confirming or rendering a thing more valid and solemn, by publication, repetition, or recognition thereof. The word comes from the Greek *ὁμολογία*, "consent, assent;" formed of *ὁμοιός*, *similis*, "like," and *λέγω*, of *λέγω*, *dicere*, "to say;" q. d. to say the same thing; to consent, agree.

HOMOLOGOUS, in *Geometry*, an appellation given to the corresponding sides and angles of similar figures, as being proportional to each other.

HONAN, a province of China, bounded on the north by that of Petcheli and Chansi, on the west by

Chansi, on the south by Houqsang, and on the east by Honan, Chantong. Every thing that can contribute to render a country delightful is found united in this province; the Chinese therefore call it *Tong-hoa*, or *the middle flower*: it is indeed situated almost in the centre of China. The ancient emperors, invited by the mildness of the climate and the beauty of the country, fixed their residence here for some time. The abundance of its fruits, pastures, and corn, the effeminacy of its inhabitants (who are accounted extremely voluptuous), and lastly, the cheapness of provisions, have no doubt prevented trade from being so flourishing here as in the other provinces of the empire. The whole country is flat excepting towards the west, where there arises a long chain of mountains, covered with thick forests; and the land is in such a high state of cultivation, that those who travel through it imagine they are walking in an immense garden.—Besides the river Hongho, which traverses this province, it is watered by a great number of springs and fountains; it has also a valuable lake, which invites to its banks a prodigious number of women, because its water has the property of communicating a lustre to silk, which cannot be imitated. Exclusive of forts, castles, and places of strength, this province contains eight *fou* or cities of the first class, and 102 of the second and third. In one of these cities named *Nanyang*, is found a kind of serpent, the skin of which is marked with small white spots; the Chinese physicians steep it in wine, and use it afterwards as an excellent remedy against the palsy.

HONAN-Fou, a city of the above province, situated amidst mountains and between three rivers. The Chinese formerly believed this city to be the centre of the earth, because it was in the middle of their empire. Its jurisdiction is very extensive; for it comprehends one city of the second class and thirteen of the third: one of these cities named *Teng-fong-hien*, is famous on account of the tower erected by the celebrated Tcheou-kong for an observatory; there is still to be seen in it an instrument which he made use of to find the shadow at noon, in order to determine the latitude. This astronomer lived above a thousand years before the Christian era, and the Chinese pretend that he invented the mariners compass.

HONDEKOOTER, MELCHIOR, a famous Dutch painter, born at Utrecht, excelled in painting animals, and especially birds. His father and grandfather were of the same profession, and their subjects the same. He was trained up to the art by his father; but surpassed not only him, but even the best of his cotemporaries, in a very high degree. Till he was seventeen years of age, he continued under the direction of his father, but particularly he was pleased to represent cocks, hens, ducks, chickens, and peacocks, which he described in an elegant variety of actions and attitudes. After his father's death, which happened in 1653, he received some instructions from his uncle John Baptist Weenix; but his principal and best instructor was nature, which he studied with intense application.—His pencil was wonderfully neat and delicate; his touch light; his colouring exceedingly natural, lively, and remarkably transparent; and the feathers of his fowls were expressed with such a swelling softness, as might have readily and agreeably deceived the eye of any spectator.

Hondekoot-spectator. It is reported that he had trained up a cock to stand in any attitude he wanted to describe, and that it was his custom to place that creature near his easel; so that at the motion of his hand the bird would fix itself in the proper posture; and would continue in that particular position without the smallest perceptible alteration for several hours at a time. The landscapes which he introduces as the back grounds of his pictures are adapted with peculiar judgment and skill, and admirably finished; they harmonize with his subject, and always increase the force and the beauty of his principal objects. His touch was very singular, in imitating the natural plumage of the fowls he painted; which not only produced a charming effect, but also may prove serviceable to an intelligent observer, to assist him in determining which are the genuine works of this master, and which are impositions. His pictures sell at a high price, and are much sought after. He died at Utrecht in 1695, aged 59.

HONDURAS, a province of North America, in New Spain, lying on the North Sea, being about 370 miles in length, and 200 in breadth; it was discovered by Christopher Columbus in the year 1501. The English have been possessed of the logwood country on the bay of Honduras a great while, and cut large quantities every year. The Mosquito native Americans live in the eastern parts; and being independent of the Spaniards, have entered into treaties with the English, and serve them in several capacities. This province is watered by several rivers, which enrich the country by their inundations; and it is very fertile in Indian corn. It is said there are some mines of gold and silver in this province. Valladolid is the capital town.

HONE, a fine kind of stone, used for setting razors, pen knives, and other cutting instruments.

HONEY, a sweet vegetable juice, collected by the bees from the flowers of various plants, and deposited in the cells of the comb; from which it is extracted either by spontaneous percolation through a sieve in a warm place, the comb being separated and laid thereon, or by expression. That which runs spontaneously is purer than that which is expressed, a quantity of the wax and other matters being forced out along with it by the pressure. The best sort of honey is of a thick consistence, a whitish colour inclining to yellow, an agreeable smell, and pleasant taste: both the colour and flavour are said to differ in some degree, according to the plants which the bees collect it from. It is supposed that honey is merely the juice of the flower perspiring, and becoming inspissated thereon, and that the bee takes it up with its proboscis, and carries it to be deposited in its waxen cells, with which the young bees are to be fed in summer, and the old ones in winter; but it is certain, that honey can be procured by no other method of collecting this juice than by the bees. The honey wrought by the young bees, and that which is permitted to run from the comb without heat or pressure, is white and pure, and called *virgin honey*. The honey of old bees, and that which is forced from the comb by heat or pressure, is yellow, from the wax. Honey produced where the air is clear and hot, is better than that where the air is variable and cold.—The honey of Narbonne in France, where rosemary abounds, is said to have a very manifest flavour of that plant, and to be imitable

by adding to other honey an infusion of rosemary flowers.

Honey, considered as a medicament, is a very useful detergent and aperient, powerfully dissolving viscid juices, and promoting the expectoration of tough phlegm. In some particular constitutions it has an inconvenience of griping, or of proving purgative, which is said to be in some measure prevented by previously boiling the honey. This, however, with all constitutions, is by no means effectual; and the circumstance mentioned has had so much weight with the Edinburgh college, that they do not now employ it in any preparation, and have entirely rejected the mella medicata, substituting syrups in their place: but there can be no doubt that honey is very useful in giving form to different articles, although there be some individuals with whom it may disagree. In order, however, to obtain the good effects of the honey itself, it must be used to a considerable extent, and as an article of diet. The following remarkable instances of the good effects of honey in some asthmatic cases, given by Mr Monro in his *Medical and Pharmaceutical Chemistry*, deserve to be here inserted. "The late Dr John Hume, one of the commissioners of the sick and hurt of the royal navy, was for many years violently afflicted with the asthma. Having taken many medicines without receiving relief, he at last resolved to try the effects of honey, having long had a great opinion of its virtues as a pectoral. For two or three years he ate some ounces of it daily, and got entirely free of his asthma, and likewise of a gravelly complaint with which he had long been afflicted. About two years after he had recovered his health, when he was sitting one day in the office for the sick and hurt, a person labouring under a great difficulty of breathing, who looked as if he could not live many days, came to him, and asked him by what means he had been cured of his asthma? Dr Hume told him the particulars of his own case, and mentioned to him the means by which he had found relief. For two years after he heard nothing of this person, who was a stranger to him, and had seemed so bad that he did not imagine he could have lived many days, and therefore had not even asked him who he was; but at the end of that period, a man seemingly in good health, and decently dressed, came to the sick and hurt office, and returned him thanks for his cure, which he assured him had been entirely brought about by the free use of honey."

HONEY-Dew, a sweet saccharine substance found on the leaves of certain trees, of which bees are very fond, by the husbandmen supposed to fall from the heavens like common dew. This opinion hath been refuted, and the true origin of this and other saccharine dews shown by the Abbé Boissier de Sauvages, in a memoir read before the Society of Sciences at Montpellier. "Chance (says the abbé) afforded me an opportunity of seeing this juice in its primitive form on the leaves of the holm oak: these leaves were covered with thousands of small round globules or drops, which, without touching one another, seemed to point out the pore from whence each of them had proceeded. My taste informed me, that they were as sweet as honey; the honey-dew on a neighbouring bramble did not resemble the former, the drops having run to-

Honey.
Honey-
Dew.

Honey-
Dew.

gether, owing either to the moisture of the air which had diluted them, or to the heat which had expanded them. The dew was become more viscous, and lay in large drops, covering the leaves; in this form it is usually seen.

"The oak had at this time two sorts of leaves: the old, which were strong and firm; and the new, which were tender, and newly come forth. The honey-dew was found only on the old leaves, though these were covered by the new ones, and by that means sheltered from any moisture that could fall from above. I observed the same on the old leaves of the bramble, while the new leaves were quite free from it. Another proof that this dew proceeds from the leaves is, that other neighbouring trees not furnished with a juice of this kind had no moisture on them: and particularly the mulberry, which is a very particular circumstance, for this juice is a deadly poison to silkworms. If this juice fell in the form of a dew, mist, or fog, it would wet all the leaves without distinction, and every part of the leaves, under as well as upper. Heat may have some share in its production: for though the common heat promotes only the transpiration of the more volatile and fluid juices, a sultry heat, especially if reflected by clouds, may so far dilate the vessel as to produce a more viscous juice, such as the honey-dew.

"The second kind of honey-dew, which is the chief resource of bees after the spring flowers and dew by transpiration on leaves are past, owes its origin to a small insect called a *vine-fretter*; the excrement ejected with some force by this insect makes a part of the most delicate honey known in nature (see APHIS). These vine-fretters rest during several months on the barks of particular trees, and extract their food by piercing that bark, without hurting or deforming the tree. These insects also cause the leaves of some trees to curl up, and produce galls upon others. They settle on branches that are a year old. The juice, at first perhaps hard and crabbed, becomes, in the bowels of this insect, equal in sweetness to the honey obtained from the flowers and leaves of vegetables; excepting that the flowers may communicate some of their essential oil to the honey, and this may give it a peculiar flavour, as happened to myself by planting a hedge of rosemary near my bees at Sauvages: the honey has tasted of it ever since, that shrub continuing long in flower.

"I have observed two species of vine-fretters, which live unsheltered on the bark of young branches; a larger and a lesser. The lesser species is of the colour of the bark upon which it feeds, generally green. It is chiefly distinguished by two horns, or straight, immovable, fleshy substances, which rise perpendicularly from the lower sides of the belly, one on each side. This is the species which lives on the young branches of bramble and elder. The larger species is double the size of the other; is of a blackish colour; and instead of the horns which distinguish the other, has in the same part of the skin a small button, black and shining like jet.

"The buzzing of bees in a tuft of holm-oak, made me suspect that something very interesting brought so many of them hither. I knew that it was not the season for expecting honey-dew, nor was it the place

where it is usually found; and was surprised to find the tuft of leaves and branches covered with drops which the bees collected with a humming noise. The form of the drops drew my attention, and led me to the following discovery. Instead of being round like drops which had fallen, each formed a small longish oval. I soon perceived from whence they proceeded. The leaves covered with these drops of honey were situated beneath a swarm of the larger black vine-fretters; and on observing these insects, I perceived them from time to time raise their bellies, at the extremity of which there then appeared a small drop of an amber colour, which they instantly ejected from them to the distance of some inches. I found by tasting some of these drops which I had caught on my hand that it had the same flavour with what had before fallen on the leaves. I afterwards saw the smaller species of vine-fretters eject their drops in the same manner. This ejection is so far from being a matter of indifference to these insects themselves, that it seems to have been wisely instituted to procure cleanliness in each individual, as well as to preserve the whole swarm from destruction; for pressing as they do one upon another, they would otherwise soon be glued together, and rendered incapable of stirring. The drops thus spurted out fall upon the ground, if not intercepted by leaves or branches; and the spots they make on stones remain some time, unless washed off by rain. This is the only honey-dew that falls; and this never falls from a greater height than a branch where these insects can cluster.

"It is now easy to account for a phenomenon which formerly puzzled me greatly. Walking under a lime-tree in the king's garden at Paris, I felt my hand wetted with little drops, which I at first took for small rain. The tree indeed should have sheltered me from the rain, but I escaped it by going from under the tree. A seat placed near the tree shone with these drops. And being then unacquainted with any thing of this kind, except the honey-dew found on the leaves of some particular trees, I was at a loss to conceive how so glutinous a substance could fall from the leaves in such small drops: for I knew that rain could not overcome its natural attraction to the leaves till it became pretty large drops; but I have since found, that the lime-tree is very subject to these vine-fretters.

"Bees are not the only insects that feast upon this honey; ants are equally fond of it. Led into this opinion by what naturalists have said, I at first believed that the horns in the lesser species of these vine-fretters had in their extremity a liquor which the ants went in search of: but I soon discovered that what drew the ants after them came from elsewhere, both in the larger and lesser species, and that no liquor is discharged by the horns. There are two species of ants which search for these insects. The large black ants follow those which live on the oaks and chestnut; the lesser ants attend those on the elder. But as the ants are not, like the bees, provided with the means of sucking up fluids; they place themselves near the vine-fretters, in order to seize the drop the moment they see it appear upon the anus; and as the drop remains some time on the small vine-fretters before they can cast it off, the ants have leisure to catch it, and thereby prevent the bees from having any share: but

Honey-
Dew.

Honey.
Dew
|
Honour.

the vine-fretters of the oak and chestnut being stronger, and perhaps more plentifully supplied with juice, dart the drop instantly, so that the larger ants get very little of it.

"The vine-fretters finding the greatest plenty of juice in trees about the middle of summer, afford also at that time the greatest quantity of honey; and this lessens as the season advances, so that in the autumn the bees prefer to it the flowers then in season. Though these insects pierce the tree to the sap in a thousand places, yet the trees do not seem to suffer at all from them, nor do the leaves lose the least of their verdure. The husbandman therefore acts injudiciously when he destroys them."

HONEY-GUIDE, a curious species of cuckow. See CUCULUS, ORNITHOLOGY *Indes*.

HONEY-LOCUST, or *Three-thorned Acacia*. See GLEDITSIA, BOTANY *Indes*.

HONEY-SUCKLE. See LONICERA, BOTANY *Indes*.

HONFLEUR, a considerable sea-port town of France, in the department of Calvados, with a good harbour, and trade in bone-lace, and with 9600 inhabitants. It is seated on the river Seine, in E. Long. O. 19. N. Lat. 25. 49.

HONI SOIT QUI MAL Y PENSE, q. d. "Evil to him that thinks evil;" the motto of the most noble order of the knights of the Garter. See GARTER.

HONITON, a very pleasant market and borough town in Devonshire, situated 156 miles west of London, and 16 east of Exeter. It contained 2735 inhabitants in 1811. It has one church on a hill full half a mile from the town, and a chapel and free grammar school in the town. It is well paved and lighted, and lakes of water run through it. This place has suffered by fires greatly in 1747 and 1765. The market is on Saturday, and one fair in July; its manufactures are serge, and rich bone-lace and edgings. It was a corporation chartered by James II. but reverted to its old constitution on the revolution, and is now governed by a portreeve who is chosen annually. It first returned members the 28th Edw. I.

HONORIACI, in antiquity, an order of soldiery under the eastern empire, who introduced the Goths, Vandals, Alani, Suevi, &c. into Spain. Didymus and Verinianus, two brothers, had, with great vigilance and valour, defended the passages of the Pyreneans against the Barbarians for some time, at their own expence; but being at length killed, the emperor Constantius appointed the *honoriaci* to defend those passages, who, not contented to lay them open to all the nations of the north then ravaging the Gauls, joined themselves to them.

HONOUR, a testimony of esteem or submission, expressed by words, actions, and an exterior behaviour, by which we make known the veneration and respect we entertain for any one on account of his dignity or merit. The word *honour* is also used in general for the esteem due to virtue, glory, and reputation. It is also used for *virtus* and *probity* themselves, and for an exactness in performing whatever we have promised; and in this last sense we use the term, *a man of honour*. But *honour* is more particularly applied to two different kinds of virtue; bravery in men, and chastity in women.—Virtue and Honour were deified among the ancient Greeks and Romans, and had a joint temple

consecrated to them at Rome; but afterwards each of them had separate temples, which were so placed that no one could enter the temple of Honour without passing through that of Virtue; by which the Romans were continually put in mind, that virtue is the only direct path to true glory. Plutarch tells us, that the Romans, contrary to their usual custom, sacrificed to Honour uncovered: perhaps to denote, that wherever honour is, it wants no covering, but shows itself openly to the world.

The Spanish historians relate a memorable instance of honour and regard to truth. A Spanish cavalier in a sudden quarrel slew a Moorish gentleman, and fled. His pursuers soon lost sight of him, for he had unperceived thrown himself over a garden wall. The owner, a Moor, happening to be in his garden, was addressed by the Spaniard on his knees, who acquainted him with his case, and implored concealment. "Eat this," said the Moor (giving him half a peach), "you now know that you may confide in my protection." He then locked him up in his garden apartment, telling him as soon as it was night he would provide for his escape to a place of greater safety. The Moor then went into his house, where he had but just seated himself, when a great crowd, with loud lamentations, came to his gate, bringing the corpse of his son, who had just been killed by a Spaniard. When the first shock of surprise was a little over, he learnt from the description given, that the fatal deed was done by the very person then in his power. He mentioned this to no one; but as soon as it was dark retired to his garden, as if to grieve alone, giving orders that none should follow him. Then accosting the Spaniard, he said, "Christian, the person you have killed is my son; his body is now in my house. You ought to suffer; but you have eaten with me, and I have given you my faith, which must not be broken." He then led the astonished Spaniard to his stables, mounted him on one of his fleetest horses, and said, "Fly far while the night can cover you; you will be safe in the morning. You are indeed guilty of my son's blood: but God is just and good; and I thank him I am innocent of yours, and that my faith given is preserved."

This point of honour is most religiously observed by the Arabs and Saracens, from whom it was adopted by the Moors of Africa, and by them was brought into Spain. The following instance of Spanish honour may still dwell in the memory of many living, and deserves to be handed down to the latest posterity. In the year 1746, when we were in hot war with Spain, the Elizabeth of London, Captain William Edwards, coming through the gulf from Jamaica, richly laden, met with a most violent storm, in which the ship sprung a leak, that obliged them, for the saving of their lives, to run into the Havana, a Spanish port. The captain went on shore, and directly waited on the governor, told the occasion of his putting in, and that he surrendered the ship as a prize, and himself and his men as prisoners of war, only requesting good quarter. "No, Sir," replied the Spanish governor, "if we had taken you in fair war at sea, or approaching our coast with hostile intentions, your ship would then have been a prize, and your people prisoners; but when, distressed by a tempest, you come into our ports for the safety of your lives, we, the enemies, being men, are bound as such by the laws of humanity to afford relief,

Honour.

Honour. relief to distressed men who ask it of us. We cannot even against our enemies take advantage of an act of God. You have leave therefore to unload your ship, if that be necessary, to stop the leak; you may reft her here, and traffic so far as shall be necessary to pay the charges; you may then depart, and I will give you a pass to be in force till you are beyond Bermuda: af after that you are taken, you will then be a lawful prize; but now you are only a stranger, and have a stranger's right to safety and protection." The ship accordingly departed, and arrived safe in London.

A remarkable instance of the like honour is recorded of a poor unenlightened African negro, in Captain Snelgrave's account of his voyage to Guinea. A New England sloop, trading there in 1752, left a second mate, William Murray, sick on shore, and sailed without him. Murray was at the house of a black named Cudjoe, with whom he had contracted an acquaintance during their trade. He recovered; and the sloop being gone, he continued with his black friend till some other opportunity should offer of his getting home. In the mean time a Dutch ship came into the road, and some of the blacks coming on board her were treacherously seized and carried off as their slaves. The relations and friends, transported with sudden rage, ran into the house of Cudjoe, to take revenge by killing Murray. Cudjoe stopt them at the door, and demanded what they wanted. "The white men," said they, "have carried away our brothers and sons, and we will kill all white men. Give us the white man you have in your house, for we will kill him." "Nay," said Cudjoe, "the white men that carried away your relations are bad men, kill them when you can take them; but this white man is a good man, and you must not kill him."—"But he is a white man," they cried: "and the white men are all bad men, we will kill them all." "Nay," says he, "you must not kill a man that has done no harm, only for being white. This man is my friend, my house is his post, I am his soldier, and must fight for him; you must kill me before you can kill him. What good man will ever come again under my roof, if I let my floor be stained with a good man's blood?" The negroes seeing his resolution, and being convinced by his discourse that they were wrong, went away ashamed. In a few days Murray ventured abroad again with his friend Cudjoe, when several of them took him by the hand, and told him, "They were glad they had not killed him; for as he was a good (meaning innocent) man, their God would have been very angry, and would have spoiled their fishing."

HONOUR, in the *beau monde*, has a meaning materially different from the above, and which it is easier to illustrate than define. It is, however, subject to a system of rules, called the *law of honour*, constructed by people of fashion, calculated to facilitate their intercourse with one another, and for no other purpose. Consequently, nothing is considered as inconsistent with honour, but what tends to incommode this intercourse. Hence, as Archbishop Paley states the matter, profaneness, neglect of public worship or private devotion, cruelty to servants, rigorous treatment of tenants or other dependents, want of charity to the poor, injuries done to tradesmen by insolvency or delay of payment, with numberless examples of the same kind, are

accounted no branches of honour; because a man is not a less agreeable companion for these vices, nor the worse to deal with in these concerns which are usually transacted between one gentleman and another. — Again, the *law of honour* being constituted by men occupied in the pursuit of pleasure, and for the mutual conveniency of such men, will be found, as might be expected from the character and design of the law-makers, to be, in most instances, favourable to the licentious indulgence of the natural passions. Thus it allows of fornication, adultery, drunkenness, prodigality, duelling, and revenge in the extreme; and lays no stress upon the virtues opposite to these.

HONOUR or Rank.—The degrees of honour which are observed in Britain may be comprehended under these two heads, viz. *nobiles majores*, and *nobiles minores*. Those included under the first rank are, archbishops, dukes, marquises, earls, viscounts, bishops, and barons; which are all distinguished by the respective ornaments of their escutcheons: and those of the last are baronets, knights, esquires, and gentlemen. There are some authors who will have baronets to be the last under the first rank; and their reason is, because their honour is hereditary, and by patent, as that of the nobility. See COMMONALTY and NOBILITY.

HONOURS of War, in a siege, is, when a governor, having made a long and vigorous defence, is at last obliged to surrender the place to the enemy for want of men and provisions, and makes it one of his principal articles to march out with the *honours of war*; that is, with shouldered arms, drums beating, colours flying, and all their baggage, &c.

Military Honours. All armies salute crowned heads in the most respectful manner, drums beating a march, colours and standards dropping, and officers saluting. Their guards pay no compliment, except to the princes of the blood; and even that by courtesy, in the absence of the crowned head.

To the commander-in-chief the whole line turns out without arms, and the camp-guards beat a march, and salute. To generals of horse and foot, they beat a march, and salute. Lieutenant-generals of ditto, three ruffs, and salute. Major-generals of ditto, two ruffs, and salute. Brigadiers of ditto, rested arms, one ruff, and salute. Colonels of ditto, rested arms, and no beating. Centinels rest their arms to all field-officers, and shoulder to every officer. All governors, that are not general officers, shall, in all places where they are governor, have one ruff, with rested arms; but for those who have no commission as governors, no drum shall beat. Lieutenant-governors shall have the main-guard turned out to them with shouldered arms.

Prussian Honours of War, chiefly imitated by most powers in Europe, are,

To the king, all guards beat the march, and all officers salute. Field-marshal received with the march, and saluted in the king's absence. General of horse or foot, four ruffs; but if he commands in chief, a march and salute. Lieutenant-generals of horse or foot, commanding or not, guards beat three ruffs. Major-generals of horse and foot, two ruffs. Officers, when their guards are under arms, and a general makes a signal, must rest to him, but not beat; when not got under arms, and a signal made, only stand by their arms.

Village-

Honour.

Village-guards go under arms only to the king, field-marshals, generals of horse and foot, and to the general of the day: Generals guards go under arms only to the king, field-marshals, and the general over whom they mount. Commanding officers of regiments and battalions, their own quarter and rear guards to turn out; but not to other field-officers, unless they are of the day. Generals in foreign service, the same.

Honours paid by Centinels. Field-marshals; two centinels with ordered firelocks, at their tent or quarters. Generals of horse or foot; two centinels, one with his firelock shouldered, the other ordered. Lieutenant-generals; one, with firelock ordered: Major-generals; one, with firelock shouldered.

The first battalion of guards go under arms to the king only; not to stand by, nor draw up in the rear of their arms to any other; nor to give centinels to foreigners. Second and third battalions draw up behind their arms to their princes, and to field-marshals; but when on grenadier guards or out-posts, they turn out, as other guards do, to the officers of the day. They give one centinel with shouldered arms to the princes of the blood, and to field-marshals when they lie alone in garrisons.

Court of HONOUR. See *Court of CHIVALRY.*

Fountain of HONOUR. The king is so styled, as being the source of honours, dignities, &c. See *PREROGATIVE.*

It is impossible that government can be maintained without a due subordination of rank; that the people may know and distinguish such as are set over them, in order to yield them their due respect and obedience; and also that the officers themselves, being encouraged by emulation and the hopes of superiority, may the better discharge their functions; and the law supposes, that no one can be so good a judge of their several merits and services as the king himself who employs them. It has therefore entrusted him with the sole power of conferring dignities and honours, in confidence that he will bestow them upon none but such as deserve them. And therefore all degrees of nobility, of knighthood, and other titles, are received by immediate grant from the crown; either expressed in writing, by writs or letters patent, as in the creation of peers and baronets; or by corporeal investiture, as in the creation of a simple knight.

From the same principle also arises the prerogative of erecting and disposing of offices; for honours and offices are in their nature convertible and synonymous. All offices under the crown carry in the eye of the law an honour along with them; because they imply a superiority of parts and abilities, being supposed to be always fitted with those that are most able to execute them. And, on the other hand, all honours in their original had duties or offices annexed to them: an earl, *comes*, was the conservator or governor of a county; and a knight, *miles*, was bound to attend the king in his wars. For the same reason therefore that honours are in the disposal of the king, offices ought to be so likewise; and as the king may create new titles, so may he create new offices; but with this restriction, that he cannot create new offices with new fees annexed to them, nor annex new fees to old offices; for this would be a tax upon the subject, which cannot be imposed but by act of parliament. Wherefore, in 13 Hen. IV. a

new office being created by the king's letters patent for measuring cloths, with a new fee for the same, the letters patent were, on account of the new fee, revoked and declared void in parliament.

Upon the same or a like reason, the king has also the prerogative of conferring privileges upon private persons. Such as granting place or precedence to any of his subjects, as shall seem good to his royal wisdom: or such as converting aliens, or persons born out of the king's dominions, into denizens; whereby some very considerable privileges of natural-born subjects are conferred upon them. Such also is the prerogative of erecting corporations; whereby a number of private persons are united and knit together, and enjoy many liberties, powers, and immunities, in their political capacity, which they were utterly incapable of in their natural.

MAIDS of Honour, are young ladies in the queen's household, whose office is to attend the queen when she goes abroad, &c. In England they are six in number, and their salary 300l. per annum each.

HONOUR is particularly applied in our customs to the more noble kind of seignories or lordships, whereof other inferior lordships or manors hold or depend. As a manor consists of several tenements, services, customs, &c. so an honour contains divers manors, knights-fees, &c. It was also formerly called *beneficium* or *royal fee*, being always held of the king *in capite*.

HONOUR-Point, in *Heraldry*, is that next above the centre of the escutcheon, dividing the upper part into two equal portions.

HONOURABLE, a title conferred on the younger sons of earls, the sons of viscounts and barons; as also on such persons as have the king's commission, and upon those who enjoy places of trust and honour.

HONOURARY, something done or conferred upon any one, to do him honour. See the article *HONOUR*.

Honourary is sometimes understood of a person who bears or possesses some post or title, only for the name's sake, without doing any thing of the functions belonging to it, or receiving any advantage from it: thus we say honourary counsellors, honourary fellows, &c.

Honourary is also used for a lawyer's fee, or a salary given to public professors in any art or science.

HOOD, ROBIN, a famous outlaw, and deer-stealer, who chiefly harboured in Sherwood forest in Nottinghamshire. He was a man of family, which by his pedigree appears to have had some title to the earldom of Huntingdon; and played his pranks about the latter end of the 12th century. He was famous for archery and for his treatment of all travellers who came in his way: levying contributions on the rich, and relieving the poor. Falling sick at last, and requiring to be blooded, he is said to have been betrayed and bled to death. He died in 1247; and was buried at Kirkstall in Yorkshire, then a Benedictine monastery, where his gravestone is still shown.

HOOD. See *CHAPERON* and *COWL*.

HOOD, in falconry, is a piece of leather, where with the head of a hawk, falcon, or the like, is covered.

Hood Island, one of the *MARQUESS Islands*, in the South sea. It was discovered in April 1774 by Captain Cook, who gave it that name from the person who first

Honour
Hood-
Island.

Hood-
Island
||
Hookah.

saw the land. It is the most northerly of the cluster, and lies in S. Lat. 9. 26. W. Long. 139. 13.

HOOF, the horny substance that covers the feet of divers animals, as oxen, horses, &c.

HOOF-bound. See *FARRIERY Index*.

HOOGLY, the name of a province, city, and river of Hindostan. See *HUGHLEY*.

HOOGESTRATTEN, a town of the Netherlands, with 1360 inhabitants, 24 miles south-west from Bois le Duc, and 30 miles north-east from Antwerp.

HOOK, in angling, &c. See *FISHING-hook*.

HOOKS, in building, &c. are of various sorts; some of iron and others of brass, viz. 1. Armour-hooks, which are generally of brass, and are to lay up arms upon, as guns, muskets, half-pikes, pikes, javelins, &c. 2. Casement-hooks. 3. Chimney-hooks, which are made both of brass and iron, and of different fashions: their use is to set the tongs and fire-shovel against. 4. Curtain-hooks. 5. Hooks for doors, gates, &c. 6. Double line-hooks, large and small. 7. Single line-hooks, large and small. 8. Tenter-hooks of various sorts. See *TENTER*.

HOOKS of a ship, are all those forked timbers which are placed directly upon the keel, as well in her run as in her rake.

Can-HOOKS, those which being made fast to the end of a rope with a noose (like that which brewers use to sling or carry their barrels on), are made use of for slings.

Foot-HOOKS, in a ship, the same with futtocks.

Loof-HOOKS, a tackle with two hooks; one to hitch into a cringle of the main or fore-sail, in the bolt-rope at the leech of the sail by the clew; and the other is to hitch into a strap, which is spliced to the chess-tree.

Their use is to pull down the sail, and succour the tackles in a large sail and stiff gale, that all the stress may not bear upon the tack. It is also used when the tack is to be seized more secure, and to take off or put on a bonnet or drabler.

HOOK-PINS, in *Architecture*, are taper iron pins, only with a hook-bead, to pin the frame of a roof or floor together.

HOOKAH, among the Arabs and other nations of the East, is a pipe of a singular and complicated construction, through which tobacco is smoked: out of a small vessel of a globular form, and nearly full of water, issue two tubes, one perpendicularly, on which is placed the tobacco; the other obliquely from the side of the vessel, and to that the person who smokes applies his mouth; the smoke by this means being drawn through water, is cooled in its passage and rendered more grateful: one takes a whiff, draws up a large quantity of smoke, puffs it out of his nose and mouth in an immense cloud, and passes the hookah to his neighbour; and thus it goes round the whole circle.—The hookah is known and used throughout the east; but in those parts of it where the refinements of life prevail greatly, every one has his hookah sacred to himself; and it is frequently an implement of a very costly nature, being of silver, and set with precious stones; in the better kind, that tube which is applied to the mouth is very long and pliant; and for that reason is termed the snake: people who use it in a luxurious manner, fill the vessel through which the smoke is drawn with rose

water, and it thereby receives some of the fragrant quality of that fluid.

HOOKER, ROBERT, a very eminent English mathematician and philosopher, was the son of Mr John Hooke minister of Freshwater, in the isle of Wight, where he was born in 1635. He very early discovered a genius for mechanics, by making curious toys with great art and dexterity. He was educated under Dr Busby in Westminster school; where he not only acquired a competent share of Greek and Latin, together with an insight into Hebrew and some other Oriental languages, but also made himself master of a considerable part of Euclid's elements. About the year 1653, he went to Christ-church in Oxford, and in 1655 was introduced to the Philosophical Society there; where, discovering his mechanical genius, he was first employed to assist Dr Willis in his operations in chemistry, and afterwards recommended to the honourable Robert Boyle, whom he served several years in the same capacity. He was also instructed in astronomy about this time by Dr Seth Ward, Savilian professor of that science; and from henceforward distinguished himself by many noble inventions and improvements of the mechanic kind. He invented several astronomical instruments, for making observations both at sea and land; and was particularly serviceable to Mr Boyle in completing the invention of the air-pump. Sir John Cutler having founded a mechanic school in 1664, he settled an annual stipend on Mr Hooke for life, intrusting the president, council, and fellows, of the Royal Society to direct him with respect to the number and subjects of his lectures; and on the 11th of January 1664-5, he was elected by that society curator of experiments for life, with an additional salary. In 1666 he produced to the Royal Society a model for rebuilding the city of London destroyed by fire, with which the society was well pleased; but although the lord mayor and aldermen preferred it to that of the city surveyor, it was not carried into execution. It is said, by one part of this model of Mr Hooke's, it was designed to have all the chief streets, as from Leaden-hall to Newgate, and the like, to lie in exact straight lines, and all the other cross streets turning out of them at right angles, with all the churches, public buildings, markets, &c. in proper and convenient places. The rebuilding of the city according to the act of parliament requiring an able person to set out the ground to the proprietors, Mr Hooke was appointed one of the surveyors; in which employment he got most part of his estate, as appeared pretty evident from a large iron chest of money found after his death, locked down with a key in it, and a date of the time, which showed it to have been so shut up above 30 years.—Mr Oldenburgh, secretary to the Royal Society, dying in 1677, Mr Hooke was appointed to supply his place, and began to take minutes at the meeting in October, but did not publish the Transactions. In the beginning of the year 1687, his brother's daughter, Mrs Grace Hooke, who had lived with him several years, died; and he was so affected with grief at her death, that he hardly ever recovered it, but was observed from that time to become less active, more melancholy, and even more cynical than ever.

Hookah.
Hooke.

ever. At the same time, a chancery suit in which he was concerned with Sir John Cutler, on account of his salary for reading the Cutlerian lectures, made him very uneasy, and increased his disorder. In 1691, he was employed in forming the plan of the hospital near Hoxton, founded by Robert Ask alderman of London, who appointed Archbishop Tillotson one of his executors; and in December the same year, Hooke was created doctor of physic, by a warrant from that prelate. In June 1696, the chancery suit with Sir John Cutler was determined in his favour, to his inexpressible satisfaction. His joy on that occasion was found in his diary thus expressed; DOMSHLGISSA: that is, *Deo, Optimo, Maximo, sit honor, laus, gloria, in secula seculorum, Amen.* "I was born on this day of July 1635, and God both given me a new birth: may I never forget his mercies to me! while he gives me breath may I praise him!"

In the same year 1696, an order was granted to him for repeating most of his experiments at the expence of the Royal Society, upon a promise of his finishing the accounts, observations, and deductions from them, and of perfecting the description of all the instruments contrived by him; but his increasing illness and general decay rendered him unable to perform it. He continued some years in this wasting condition; and thus languishing till he was quite emaciated, he died March 3d 1702, at his lodgings in Gresham college, and was buried in St Helen's church, Bishopsgate street; his corpse being attended by all the members of the Royal Society then in London.

Dr Hooke's character, in some respects, was not one of the most amiable. In his person he exhibited but a mean appearance, being short of stature, very crooked, pale, lean, and of a meagre aspect, with lank brown hair, which he wore very long, and hanging over his face. Suitable to his person, his temper was penurious, melancholy, mistrustful: and, though possessed of great philosophical knowledge, he had so much ambition, that he would be thought the only man who could invent or discover; and thus it has been asserted by some, that he frequently laid claim to the inventions and discoveries of others, while he boasted of many of his own which he never communicated. On the contrary his admirers have retorted the charge, and have blamed others with claiming the discoveries of this philosopher. Without deciding on this point, which seems at least somewhat doubtful, we shall leave our readers to judge for themselves, after recommending to their perusal the history of the inventions claimed by Dr Hooke at the end of this article, and the note under the article WATCH, both drawn up, we believe, by Professor Robison. In the religious part of his character he was so far exemplary, that he always expressed a great veneration for the Deity; and seldom received any remarkable benefit in life, or made any considerable discovery in nature, or invented any useful contrivance, or found out any difficult problem, without setting down his acknowledgement to God, as many places in his diary plainly show. He frequently studied the sacred writings in the original; for he was acquainted with the ancient languages, as well as with all parts of the mathematics.—He wrote, 1. *Lectiones Cutlerianae*, or Cutlerian Lectures. 2. *Micrographia*, or Descriptions of minute bodies made by magnifying glasses. 3. A de-

scription of helioscopes. 4. A description of some mechanical improvements of lamps and water-raises, quarto. 5. Philosophical collections. After his death were published, 6. Posthumous works collected from his papers by Richard Waller secretary to the Royal Society.

Chronological History of Inventions and Discoveries by Dr Hooke.

1656, Barometer, a weather-glass.

1657, A scapement, for maintaining the vibration of a pendulum.—And not long after, the regulating or balance-spring for watches.

1658, The double barrelled air-pump.—The conical pendulum.—His first emolument of the conical pendulum was no less ingenious and scientific than it was original. He employed it to represent the mutual gravitation of the planets; a fact which he had most systematically announced. He had shewn, that a force, perfectly analogous to gravity on this earth, operated on the surface of the moon and of Jupiter. Considering the numerous round pits on the surface of the moon, surrounded with a sort of wall, and having a little eminence in the middle, as the production of volcanoes, he inferred, that the ejected matter fell back again to the moon, as such matter falls back again to the earth. He saw Jupiter surrounded with an atmosphere, which accompanied him; and therefore pressed on him, as our air presses on the earth:—He inferred, that it was the same kind of power that maintained the sun and other planets in a round form. He inferred a force to the sun from the circulation round him, and he called it a *gravitation*; and said that it was not the earth which described the ellipse, but the centre of gravity of the earth and moon. He therefore made a conical pendulum, whose tendency to a vertical position represented the gravitation to the sun, and which was projected at right angles to the vertical plane; and shewed experimentally, how the different proportions of the projectile and centripetal tendencies produced various degrees of eccentricity in the orbit. He then added another pendulum, describing a cone round the first, while this described a cone round the vertical line, in order to see what point between them described the ellipse. The results of the experiment were intricate and unsatisfactory; but the thought was ingenious. He candidly acknowledged, that he had not discovered the true law of gravitation which would produce the description of an ellipse round the focus, owing to his want of due mathematical knowledge; and therefore left this investigation to his superiors. Sir Isaac Newton was the happy man who made the discovery, after having entertained the same notions of the forces which connected the bodies of the solar system, before he had any acquaintance with Dr Hooke, or knew of his speculations.

1660, The engine for cutting clock and watch-wheels.—The chief phenomena of capillary attraction.—The freezing of water a fixed temperature.

1663, The method of supplying air to a diving bell. The number of vibrations made by a musical chord.

1664, His *Micrographia* was, by the council of the Royal Society, ordered to be printed; but in that work are many just notions respecting respiration, the com-

Hooke. position of the atmosphere; and the nature of light, which were afterwards attributed as discoveries to Mayow and others, who, though we are far from supposing that they stole their discoveries from Dr Hooke, were certainly anticipated by him.

1666, A quadrant by reflection.

1667, The marine barometer.—The gage for sounding unfathomable depths.

1668, The measurement of a degree of the meridian, with a view to determine the figure of the earth, by means of a zenith sector.

1669, The fact of the *conservatio virium vivarum*, and that in all the productions and extinctions of motion, the accumulated forces were as the squares of the final or initial velocities. This doctrine he announces in all its generality and importance, deducing from it all the consequences which John Bernoulli values himself so highly upon, and which are the chief facts adduced by Leibnitz in support of his doctrine of the forces of bodies in motion. But Hooke was perfectly aware of their entire correspondence with the Cartesian or common doctrine, and was one of the first in applying the celebrated 39th proposition of Newton's Principia to his former positions on this subject, as a mathematical demonstration of them.

1673, That the catenaria was the best form of an arch.

1674, Steam engine on Newcomen's principle.

1679, That the air was the sole source of heat in burning: That combustion is the solution of the inflammable vapour in air; and that in this solution the air gives out its heat and light. That nitre explodes and causes bodies to burn without air, because it consists of this air accompanied by its heat and light in a condensed or solid state, and air supports flame, because it contains the same ingredients that gunpowder doth, that is, a nitrous spirit: That this air dissolves something in the blood while it is exposed to it in the lungs in a very expanded surface, and when saturated with it, can no longer support life nor flame; but in the act of solution, it produces animal heat: That the arterial and venal blood differ on account of this something being wanting in one of them. In short, the fundamental doctrines of modern chemistry are systematically delivered by Dr Hooke in his *Micrographia*, published in 1664, and his *Lampas*, published in 1677:

1680, He first observed the secondary vibrations of elastic bodies, and their connection with harmonic sounds. A glass containing water, and excited by a fiddlestick, threw the water into undulations, which were square, hexagonal, octagonal, &c. shewing that it made vibrations subordinate to the total vibration; and that the fundamental sound was accompanied by its octave, its twelfth, &c.

1681, He exhibited musical tones by means of toothed wheels, whirled round and rubbed with a quill, which dropped from tooth to tooth, and produced tones proportioned to the frequency of the cracks or snaps.

1684, He read a paper before the Royal Society, in which he affirms, that some years before that period he had proposed a method of discoursing at a distance, not by sound but by sight. He then proceeds to describe a very accurate and complete telegraph, equal, perhaps, in all respects to those now in use. But some years previous to 1684, M. Amontons had not invent-

ed his telegraph; so that, though the marquis of Worcester unquestionably gave the first hint of this instrument, Dr Hooke appears to have first brought it to perfection. See TELEGRAPH; and a book, published 1726, entitled *Philosophical Experiments and Observations* of the late eminent Dr Robert Hooke.

To him also we are indebted for many other discoveries of lesser note; such as the wheel barometer, the universal joint, the manometer, screw divided quadrant, telescopic sights for astronomical instruments, representation of a muscular fibre by a chain of bladders, experiments shewing the inflection of light, and its attraction for solid bodies, the curvilinear path of light through the atmosphere.

HOOKER, *Nathaniel*, author of an esteemed Roman history and other performances. Of this learned gentleman the earliest particulars to be met with are furnished by himself, in the following modest but manly address to the earl of Oxford, dated Oct. 7. 1722: "My Lord, the first time I had the honour to wait ^{Nichols's} upon your lordship since your coming to London, ^{Anecdotes} your lordship had the goodness to ask me, what way ^{of Bower,} of life I was then engaged in? A certain ^{Sc. c.} *mauvaise honte* hindered me at that time from giving a direct answer. The truth is, my lord, I cannot be said at present to be in any form of life, but rather to live extempore. The late epidemical distemper seized me, I endeavoured to be rich, imagined for a while that I was, and am in some measure happy to find myself at this instant but just worth nothing. If your lordship, or any of your numerous friends, have need of a servant with the bare qualifications of being able to read and write, and to be honest, I shall gladly undertake any employments your lordship shall not think me unworthy of. I have been taught, my lord, that neither a man's natural pride, nor his self-love, is an equal judge of what is fit for him; and I shall endeavour to remember, that it is not the short part we act, but the manner of our performance, which gains or loses us the applause of Him who is finally to decide of all human actions. My lord, I am just now employed in translating from the French, a History of the Life of the late Archbishop of Cambrai; and I was thinking to beg the honour of your lordship's name to protect a work which will have so much need of it. The original is not yet published. 'Tis written by the author of the Discourse upon Epic Poetry, in the new edition of Telemaque. As there are some passages in the book of a particular nature, I dare not solicit your lordship to grant me the favour I have mentioned, till you first have perused it. The whole is short, and pretty fairly transcribed. If your lordship could find a spare hour to look it over, I would wait upon your lordship with it, as it may possibly be no unpleasing entertainment. I should humbly ask your lordship's pardon for so long an address in a season of so much business. But when should I be able to find a time in which your lordship's goodness is not employed? I am with perfect respect and duty, my lord, your lordship's most obliged, most faithful, and most obedient humble servant, NATHANIEL HOOKE." The translation here spoken of was afterwards printed in 12mo, 1723. From this period till his death, Mr Hooke enjoyed the confidence and patronage of men not less distinguished by virtue than by titles. In 17... he published a translation

Hooke.

lation of Ramsay's Travels of Cyrus, in 4to; in 1733 he revised a Translation of "The History of the Conquest of Mexico by the Spaniards, by Thomas Townsend, Esq." printed in 2 vols 8vo; and in the same year he published, in 4to, the first volume of "The Roman History, from the building of Rome to the ruin of the Commonwealth; illustrated with maps and other plates." In the dedication to this volume, Mr Hooke took the opportunity of "publicly testifying his just esteem for a worthy friend, to whom he had been long and much obliged," by telling Mr Pope, that the displaying of his name at the head of these sheets was "like the hanging out a splendid sign, to catch the traveller's eye, and entice him to make trial of the entertainment the place affords. But, (he proceeds), when I can write under my sign, that Mr Pope has been here, and was content, who will question the goodness of the house?" The volume is introduced by "Remarks on the History of the Seven Roman Kings, occasioned by Sir Isaac Newton's objections to the supposed 244 years duration of the royal state of Rome." His nervous pen was next employed in digesting "An Account of the conduct of the Dowager-duchess of Marlborough, from her first coming to court to the year 1710, in a Letter from herself to Lord — in 1742," 8vo. His reward on this occasion was considerable; and the reputation he acquired by the performance much greater. The circumstances of this transaction are thus related by Dr Maty, in his Memoirs of Lord Chesterfield, vol. i. p. 116. "The relict of the great duke of Marlborough, being desirous of submitting to posterity her political conduct, as well as her lord's, applied to the earl of Chesterfield for a proper person to receive her information, and put the memoirs of her life into a proper dress. Mr Hooke was recommended by him for that purpose. He accordingly waited upon the duchess, while she was still in bed, oppressed by the infirmities of age. But, knowing who he was, she immediately got herself lifted up, and continued speaking during six hours. She delivered to him, without any notes, her account in the most lively as well as the most connected manner. As she was not tired herself, she would have continued longer the business of this first sitting, had not she perceived that Mr Hooke was quite exhausted, and wanted refreshment as well as rest. So eager was she for the completion of the work, that she insisted upon Mr Hooke's not leaving her house till he had finished it. This was done in a short time; and her Grace was so well pleased with the performance, that she complimented the author with a present of 5000*l.* a sum which far exceeded his expectations. As soon as he was free, and permitted to quit the house of his benefactress, he hastened to the earl, to thank him for his favour, and communicated to him his good fortune. The perturbation of mind he was under, occasioned by the strong sense of his obligation, plainly appeared in his stammering out his acknowledgments: and he, who had succeeded so well as the interpreter of her Grace's sentiments, could scarcely utter his own." The second volume of his Roman History appeared in 1745; when Mr Hooke embraced the fair occasion of congratulating his worthy friend the earl of Marchmont, on "that true glory, the consenting praise of the honest and the

wise," which his lordship had so early acquired. To the second volume Mr Hooke added "The Capitoline Marbles, or Consular Calenders, an ancient Monument accidentally discovered at Rome in the year 1545, during the Pontificate of Paul III." In 1758 Mr Hooke published Observations on, I. The Answer of M. l'Abbé de Vertot to the earl of Stanhope's Inquiry concerning the Senate of ancient Rome: dated December 1716. II. A Dissertation upon the Constitution of the Roman Senate, by a Gentleman: published in 1743. III. A Treatise on the Roman Senate, by Dr Conyers Middleton: published in 1747. IV. An Essay on the Roman Senate, by Dr Thomas Chapman: published in 1750; which he with great propriety inscribed to Mr Speaker Onslow. The third volume of Mr Hooke's Roman History to the end of the Gallic war, was printed under his inspection before his last illness; but did not appear till after his death, which happened in 1764. The fourth and last volume was published in 1771. Dr Hooke left two sons; of whom one is a divine of the church of England; the other, a doctor of the Sorbonne, and professor of astronomy in that illustrious seminary.

HOOKER, JOHN, *alias* VOWELL, was born in Exeter, about the year 1524, the second son of Robert Hooker, who in 1529 was mayor of that city. He was instructed in grammar learning by Dr Moreman, vicar of Menhinit in Cornwall, and thence removed to Oxford; but to what college is uncertain. Having left the university, he travelled to Germany, and resided some time at Cologne, where he kept exercises in law, and probably graduated. Thence he went to Strasburg, where he studied divinity under the famous Peter Martyr. He now returned to England, and soon after visited France, intending to proceed to Spain and Italy; but was prevented by a declaration of war. Returning therefore again to England, he fixed his residence in his native city, where, having married, he was in 1554 elected chamberlain, being the first person who held that office, and in 1571 represented his fellow-citizens in parliament. He died in the year 1601, and was buried in the cathedral church at Exeter. He wrote, among other works, 1. Order and usage of keeping of parliaments in Ireland. 2. The events of comets or blazing stars, made upon the sight of the comet Pagouia, which appeared in November and December 1577. 3. An addition to the chronicles of Ireland from 1546 to 1568; in the second volume of Holinshed's chronicle. 4. A description of the city of Exeter, and of the sondrie assaults given to the same; Holinsh. Chron. vol. iii. 5. A book of ensigns. 6. Translation of the history of the conquest of Ireland from the Latin of Giraldus Cambrensis; in Holinsh. Chron. vol. ii. 7. *Synopsis chorographica*, or an historical record of the province of Devon; never printed.

HOOKER, Richard, a learned divine, was born at Heavy-tree, near Exeter, in the year 1553. Some of his ancestors were mayors of that city, and he was nephew to John HOOKER the historian. By his uncle he was first supported at the university of Oxford, with the addition of a small pension from Dr Jewel, bishop of Salisbury, who in 1561 got him admitted one of the clerks of Corpus-Christi college. In 1573 he was elected scholar. In 1577 he took the degree of master of

Hooke.
H. ser.

Hooker
Hooper.

arts; and was admitted fellow the same year. In July 1579, he was appointed deputy professor of the Hebrew language. In October, in the same year, he was for some trivial misdemeanor expelled the college, but was immediately restored. In 1581 he took orders; and, being appointed to preach at St Paul's cross, he came to London, where he was unfortunately drawn into a marriage with Joan Churchman, the termagant daughter of his hostess. Having thus lost his fellowship, he continued in the utmost distress till the year 1584, when he was presented by John Cheney, Esq. to the rectory of Drayton-Beacham in Buckinghamshire. In this retirement he was visited by Mr Edwin Sandys, and Mr George Cranmer, his former pupils. They found him, with a Horace in his hand, tending some sheep in the common field, his servant having been ordered home by his sweet Xantippe. They attended him to his house; but were soon deprived of his company by an order, from his wife Joan, for him to come and rock the cradle. Mr Sandys's representation to his father, of his tutor's situation, procured him the mastership of the Temple. In this situation he met with considerable molestation from one Travers, lecturer of the Temple, and a bigotted Puritan, who in the afternoon endeavoured to confute the doctrine delivered in the morning. From this disagreeable situation he solicited Archbishop Whitgift to remove him to some country retirement, where he might prosecute his studies in tranquillity. Accordingly in 1591, he obtained the rectory of Boscomb in Wiltshire, together with a prebend in the church of Salisbury, of which he was also made sub-dean. In 1594 he was presented to the rectory of Bishopsbourne in Kent, where he died in the year 1600. He was buried in his own parish-church, where a monument was erected to his memory by William Cooper, Esq. He was a meek, pious, and learned divine. He wrote, 1. Ecclesiastical politie, in eight books folio. 2. A discourse of justification; &c. with two other sermons, Oxford 1612, 4to. Also several other sermons printed with the Ecclesiastical Politie.

HOOKER, in naval architecture, a vessel much used by the Dutch, built like a pink, but rigged and masted like a hoy.—Hookers will lie nearer a wind than vessels with cross-sails can do. They are from 50 to 200 tons burden, and with a few hands will sail to the East Indies.

HOOP, a piece of pliant wood, or iron, bent into a circular form, commonly used for securing casks, &c.

Driving a Hoop, a boyish exercise, of good effect in rendering the limbs pliable, and for strengthening the nerves.

HOOPER, JOHN, bishop of Worcester, and a martyr in the Protestant cause, was born in Somersetshire, and educated at Oxford, probably in Merton-college. In 1518 he took the degree of bachelor of arts, and afterwards became a Cistercian monk; but at length, disliking his fraternity, he returned to Oxford, and there became infected with Lutheranism. In 1539 he was made chaplain and house-steward to Sir John Arundel, who afterwards suffered with the protector in the reign of Edward VI. But *that very catholic knight*, as Wood calls him, discovering his chaplain to be a heretic, Hooper was obliged to leave the kingdom. After continuing some time in France, he returned to Eng-

land, and lived with a gentleman called *Saintlow*; but being again discovered, he escaped in the habit of a sailor to Ireland; thence embarked for the continent, and fixed his abode in Switzerland.—When King Edward came to the crown, Mr Hooper returned once more to his native country. In 1550, by his old patron Sir John Arundel's interest with the earl of Warwick, he was consecrated bishop of Gloucester; and in 1552 was nominated to the see of Worcester, which he held *in commendam* with the former. But Queen Mary had scarce ascended the throne, before his lordship was imprisoned, tried, and, not choosing to recant, condemned to the flames. He suffered this terrible death at Gloucester, on the 9th of February 1554, being then near 60 years of age. He was an avowed enemy to the church of Rome, and not perfectly reconciled to what he thought remnants of Popery in the church of England. In the former reign he had been one of Bonner's accusers, which sufficiently accounts for his being one of Queen Mary's first sacrifices to the holy see. He was a person of good parts and learning, as may be found in Fox's Book of Martyrs.

HOOPER, *George*, a very learned writer, bishop of Bath and Wells, was well skilled in mathematics, and in the eastern learning and languages. He sat in those sees above 25 years, often refused a seat in the privy council, and could not be prevailed upon to accept of the bishopric of London on the death of Bishop Compton. He wrote, 1. The church of England free from the imputation of Popery. 2. A discourse concerning Lent. 3. New danger of Presbytery. 4. An enquiry into the state of the ancient measures. 5. *De Valentianorum heresi conjecturas*. 6. Several sermons; and other works.

HOOPING-COUGH. See MEDICINE *Index*.

HOOPOE. See UPUPA, ORNITHOLOGY *Index*.

HOP, in Botany. See HUMULUS, BOTANY *Index*.

Hops were first brought into England from the Netherlands in the year 1524. They are first mentioned in the English statute book in the year 1552, viz. in the 5 and 6 of Edw. VI. cap. 5. And by an act of parliament of the first year of King James I. anno 1603, cap. 18. it appears, that hops were then produced in abundance in England.

The hop being a plant of great importance in the article of brewing, we shall consider what relates to the culture and management of it, under the following heads:

Of Soil. As for the choice of their hop grounds, they esteem the richest and strongest grounds the most proper; and if it be rocky within two or three feet of the surface the hops will prosper well; but they will by no means thrive on a stiff clay or spongy wet land.

The Kentish planters account new land best for hops; they plant their hop gardens with apple-trees at a large distance, and with cherry-trees between; and when the land hath done its best for hops, which they reckon it will in about 10 years, the trees may begin to bear. The cherry-trees last about 30 years; and by that time the apple-trees are large, they cut down the cherry-trees.

The Essex planters account a moory land the most proper for hops.

As to the situation of a hop-ground, one that in-

Hooper
Hops.

Hops. clines to the south or west is the most eligible; but if it be exposed to the north-east or south-west winds, there should be a shelter of some trees at a distance, because the north-east winds are apt to nip the tender shoots in the spring; and the south-west winds frequently break and blow down the poles at the latter end of the summer, and very much endanger the hops.

In the winter-time provide your soil and manure for the hop-ground against the following spring.

If the dung be rotten, mix it with two or three parts of common earth, and let it incorporate together till you have occasion to make use of it in making your hop hills; but if it be new dung, then let it be mixed as before till the spring in the next year, for new dung is very injurious to hops.

Dung of all sorts was formerly more commonly made use of than it is now, especially when rotted and turned to mould, and they who have no other manure must use it; which if they do, cows or hogs dung, or human ordure mixed with mud, may be a proper compost, because hops delight most in a manure that is cool and moist.

Planting. Hops require to be planted in a situation so open, as that the air may freely pass round and between them, to dry up and dissipate the moisture, whereby they will not be subject to fire-blasts, which often destroy the middles of large plantations while the out-sides remain unurt.

As for the preparation of the ground for planting, it should, in the preceding winter, be ploughed and harrowed even; and then lay upon it in heaps a good quantity of fresh rich earth, or well rotted dung and earth mixed together, sufficient to put half a bushel in every hole to plant the hops in, unless the natural ground be very fresh and good.

The hills where the hops are to be planted should be eight or nine feet asunder, that the air may freely pass between them; for in close plantations they are very subject to what the hop-planters call the *fire-blast*.

If the ground is intended to be ploughed with horses between the hills, it will be best to plant them in squares chequerwise; but if the ground is so small that it may be done with the breast-plough or spade, the holes should be ranged in a quincunx form. Which way so ever you make use of, a stake should be stuck down at all the places where the hills are to be made.

Persons ought to be very curious in the choice of the plants as to the kind of hop; for if the hop-garden be planted with a mixture of several sorts of hops that ripen at several times, it will cause a great deal of trouble, and be a great detriment to the owner.

The two best sorts are the white and the gray bind; the latter is a large square hop, more hardy, and is the more plentiful bearer, and ripens later than the former.

There is also another sort of the white bind, which ripens a week, or ten days before the common; but this is tenderer, and a less plentiful bearer; but it has this advantage, that it comes first to market.

But if three grounds, or three distant parts of one ground, be planted with these three sorts, there will be this conveniency, that they may be picked successively as they become ripe. The sets should be five

or six inches long, with three or more joints or buds on them.

If there be a sort of hop you value, and would increase plants and sets from, the superfluous binds may be laid down when the hops are tied, cutting off the tops, and burying them in the hill; or when the hops are dressed, all the cuttings may be saved; for almost every part will grow, and become a good set the next spring.

As to the seasons of planting hops, the Kentish planters best approve the months of October and March, both which sometimes succeed very well; but the sets are not to be had in October, unless from some ground that is to be destroyed; and likewise there is some danger that the sets may be rotted, if the winter prove very wet; therefore the most usual time of procuring them is in March, when the hops are cut and dressed.

As to the manner of planting the sets, there should be five good sets planted in every hill, one in the middle, and the rest round about sloping, the tops meeting at the centre; they must stand even with the surface of the ground; let them be pressed close with the hand, and covered with fine earth, and a stick should be placed on each side the hill to secure it.

The ground being thus planted, all that is to be done more during that summer, is to keep the hills clear from weeds, and to dig up the ground about the month of May, and to raise a small bill round about the plants. In June you must twist the young bind or branches together into a bunch or knot; for if they are tied up to small poles the first year, in order to have a few hops from them, it will not countervail the weakening of the plants.

A mixture of compost or dung being prepared for your hop-ground, the best time for laying it on, if the weather prove dry, is about Michaelmas, that the wheels of the dung-cart may not injure the hops, nor furrow the ground: if this be not done then, you must be obliged to wait till the frost has hardened the ground, so as to bear the dung-cart; and this is also the time to carry on your new poles, to recruit those that are decayed, and to be cast out every year.

If you have good store of dung, the best way will be to spread it in the alleys all over the ground, and to dig it in the winter following. The quantity they will require will be 40 loads to an acre, reckoning about 30 bushels to the load.

If you have not dung enough to cover all the ground in one year, you may lay it on one part one year, and on the rest in another, or a third; for there is no occasion to dung the ground after this manner oftener than once in three years.

Those who have but a small quantity of dung, usually content themselves with laying on about twenty loads upon an acre every year; this they lay only on the hills, either about November, or in the spring; which last some account the best time, when the hops are dressed, to cover them after they are cut; but if it be done at this time, the compost or dung ought to be very well rotted and fine.

Dressing. As to the dressing of the hops, when the hop-ground is dug in January or February, the earth about the hills, and very near them, ought to be taken

Hops. away with a spade, that you may come the more conveniently at the stock to cut it.

About the end of February, if the hops were planted the spring before, or if the ground be weak, they ought to be dressed in dry weather; but else, if the ground be strong and in perfection, the middle of March will be a good time: and the latter end of March, if it be apt to produce over-rank binds, or the beginning of April, may be soon enough.

Then having with an iron picker cleared away all the earth out of the hills, so as to clear the stock to the principal roots, with a sharp knife you must cut off all the shoots which grew up with the binds the last year; and also all the young suckers, that none be left to run in the alley, and weaken the hill. It will be proper to cut one part of the stock lower than the other, and also to cut that part low that was left highest the preceding year. By pursuing this method you may expect to have stronger buds, and also keep the hill in good order.

In dressing those hops that have been planted the year before, you ought to cut off both the dead tops and the young suckers which have sprung up from the sets, and also to thicken the stocks with fine earth a finger's length in thickness.

The poling. About the middle of April the hops are to be poled, when the shoots begin to sprout up; the poles must be set to the hills deep into the ground, with a square iron picker or crow, that they may the better endure the winds; three poles are sufficient for one hill. These should be placed as near the hill as may be, with their bending tops turned outwards from the hill, to prevent the binds from entangling; and a space between two poles ought to be left open to the south to admit the sun-beams.

The poles ought to be in length 16 or 20 feet, more or less according as the ground is in strength; and great care must be taken not to overpole a young or weak ground, for that will draw the stock too much and weaken it. If a ground be overpoled, you are not to expect a good crop from it; for the branches which bear the hops will grow very little till the binds have over-reached the poles, which they cannot do when the poles are too long. Two small poles are sufficient for a ground that is young.

If you wait till the sprouts or young binds are grown to the length of a foot, you will be able to make a better judgment where to place the largest poles; but if you stay till they are so long as to fall into the alleys, it will be injurious to them, because they will entangle one with another, and will not clasp about the pole readily.

Maple or aspen poles are accounted the best for hops, on which they are thought to prosper best, because of their warmth; or else, because the climbing of the hop is promoted by means of the roughness of the bark. But for durability, ash or willow poles are preferable; but chesnut poles are the most durable of all.

If after the hops are grown up you find any of them have been under-poled, taller poles may be placed near those that are too short to receive the binds from them.

The tying. As to the tying of hops, the buds that do not clasp of themselves to the nearest pole when

Hops. they are grown to three or four feet high, must be guided to it by the hand, turning them to the sun, whose course they will always follow. They must be bound with withered rushes, but not so close as to hinder them from climbing up the pole.

This you must continue to do till all the poles are furnished with binds, of which two or three are enough for a pole; and all the sprouts and binds that you have no occasion for are to be plucked up; but if the ground be young, then none of these useless binds should be plucked up, but should be wrapt up together in the middle of the hill.

When the binds are grown beyond the reach of your hands, if they forsake the poles, you should make use of a stand-ladder in tying them up.

Towards the latter end of May, when you have made an end of tying them, the ground must have the summer dressing: this is done by casting up with the spade some fine earth into every hill; and a month after this is done, you must hoe the alleys with a Dutch hoe, and make the hills up to a convenient bigness.

Gathering. About the middle of July hops begin to blow, and will be ready to gather about Bartholomew Tide. A judgment may be made of their ripeness by their strong scent, their hardness, and the brownish colour of their seed.

When by these tokens they appear to be ripe, they must be picked with all the expedition possible; for if at this time a storm of wind should come, it would do them great damage by breaking the branches, and bruising and discolouring the hops; and it is very well known that hops, being picked green and bright, will sell for a third part more than those which are discoloured and brown.

The most convenient way of picking them is into a long square frame of wood, called a *bin*, with a cloth hanging on tenter hooks within it, to receive the hops as they are picked.

The frame is composed of four pieces of wood joined together, supported by four legs, with a prop at each end to bear up another long piece of wood placed at a convenient height over the middle of the bin; this serves to lay the poles upon which are to be picked.

The bin is commonly eight feet long, and three feet broad; two poles may be laid on it at a time, and six or eight persons may work at it, three or four on each side.

It will be best to begin to pick the hops on the east or north side of your ground, if you can do it conveniently; this will prevent the south-west wind from breaking into the garden.

Having made choice of a spot of the ground containing 11 hills square, place the bin upon the hill which is in the centre, having five hills on each side; and when these hills are picked, remove the bin into another piece of ground of the same extent, and so proceed till the whole hop-ground is finished.

When the poles are drawn up to be picked, you must take great care not to cut the binds too near the hills, especially when the hops are green, because it will make the sap to flow excessively.

The hops must be picked very clean, i. e. free from leaves and stalks; and, as there shall be occasion, two

Hops.

or three times in a day the bin must be emptied into a hop-bag made of coarse linnen cloth, and carried immediately to the oast or kiln in order to be dried; for if they should be long in the bin or bag, they will be apt to heat and be discoloured,

If the weather be hot, there should no more poles be drawn than can be picked in an hour, and they should be gathered in fair weather, if it can be, and when the hops are dry; this will save some expence in firing, and preserve their colour better when they are dried.

The crop of hops being thus bestowed, you are to take care of the poles against another year, which are best to be laid up in a shed, having first stripped off the baulm from them; but if you have not that conveniency, set up three poles in the form of a triangle, or six poles (as you please) wide at bottom; and having set them into the ground, with an iron picker, and bound them together at the top, set the rest of your poles about them; and being thus disposed, none but those on the outside will be subject to the injuries of the weather, for all the inner poles will be kept dry, unless at the top; whereas, if they were on the ground, they would receive more damage in a fortnight than by their standing all the rest of the year.

Drying. The best method of drying hops is with charcoal on an oast or kiln, covered with hair-cloth, of the same form and fashion that is used for drying malt. There is no need to give any particular directions for making these, since every carpenter or bricklayer in those countries where hops grow, or malt is made, knows how to build them.

The kiln ought to be square, and may be of 10, 12, 14, or 16 feet over at the top, where the hops are laid, as your plantation requires, and your room will allow. There ought to be a due proportion between the height and breadth of the kiln and the bequels of the steddle where the fire is kept, viz. if the kiln be 12 feet square on the top, it ought to be nine feet and a half square, and so proportionable in other dimensions.

The hops must be spread even upon the oast a foot thick or more, if the depth of the curb will allow it; but care is to be taken not to overload the oast if the hops be green or wet.

The oast ought to be first warmed with a fire before the hops are laid on, and then an even steady fire must be kept under them; it must not be too fierce at first, lest it scorch the hops, nor must it be suffered to sink or slacken, but rather be increased till the hops be nearly dried, lest the moisture or sweat which the fire has raised fall back or discolour them. When they have lain about nine hours they must be turned, and in two or three hours more they may be taken off the oast. It may be known when they are well dried by the brittleness of the stalks and the easy falling off of the hop leaves.

It is found by experience that the turning of hops, though it be after the most easy and best manner, is not only an injury or waste to the hops, but also an expence of fuel and time, because they require as much fuel and as long a time to dry a small quantity, by turning them, as a large one. Now this may be prevented by having a cover (to be let down and raised at pleasure) to the upper bed wherem the hops lie.

Hops.

This cover may also be tinned, by nailing single tin plates over the face of it; so that when the hops begin to dry, and are ready to burn, i. e. when the greatest part of their moisture is evaporated, then the cover may be let down within a foot or less of the hops (like a reverberatory), which will reflect the heat upon them, so that the top will soon be as dry as the lowermost, and every hop be equally dried.

Bagging. As soon as the hops are taken off the kiln, lay them in a room for three weeks or a month to cool, give, and toughen; for if they are bagged immediately they will powder, but if they lie a while (and the longer they lie the better, provided they be covered close with blankets to secure them from the air) they may be bagged with more safety, as not being liable to be broken to powder in treading; and this will make them bear treading the better, and the harder they are trodden the better they will keep.

The common method of bagging is as follows: they have a hole made in an upper floor, either round or square, large enough to receive a hop-bag, which consists of four ells and a half of ell-wide cloth, and also contains ordinarily two hundred and a half of hops; they tie a handful of hops in each lower corner of the bag to serve as handles to it; and they fasten the mouth of the bag, so placed that the hoop may rest upon the edges of the hole.

Then he that is to tread the hops down into the bag, treads the bag on every side, another person continually putting them in as he treads them till the bag is full; which being well filled and trodden, they unrip the fastening of the bag to the hoops, and let it down, and close up the mouth of the bag, tying up a handful of hops in each corner of the mouth, as was done in the lower part.

Hops being thus packed, if they have been well dried, and laid up in a dry place, will keep good several years; but care must be taken that they be neither destroyed nor spoiled by the mice making their nests in them.

Produce. The charge of an acre of hop-ground in most parts of England where hops are cultivated, is computed thus: three pounds for the husbandry, four pounds for the wear of the poles, five pounds for picking and drying, one pound ten shillings for dung, one pound for rent, though in some places they pay four or five pounds an acre yearly for the rent of the land, and ten shillings for tythe; in all 15l. a year. The hop-planters in England reckon that they have but a moderate return, when the produce of an acre of hops does not sell for more than 30l. They frequently have fifty, sixty, eighty, or a hundred pounds; and in a time of general scarcity considerably more: so that, upon the whole, if the total charge of an acre of hops is computed at fifteen pounds a-year, and its average produce at thirty pounds, the clear profit from an acre will be fifteen pounds a-year. But the plantation of hops has lately so much increased, and the average produce so much exceeded the consumption, that hops have been with many planters rather a losing than a very profitable article.

Uses. In the spring-time, while the bud is yet tender, the tops of the plant being cut off, and boiled, are ate like asparagus, and found very wholesome, and effectual to loosen the body; the heads and tendrils are

good..

Hops.

good to purify the blood in the scurvy, and most cutaneous diseases; decoctions of the flowers, and syrups thereof, are of use against pestilential fevers; juleps and apozems are also prepared with hops for hypochondriacal and hysterical affections, and to promote the menses.

A pillow stuffed with hops and laid under the head, is said to procure sleep in fevers attended with a delirium. But the principal use of hops is in the brewery, for the preservation of malt liquors; which by the superaddition of this balsamic, aperient, and diuretic bitter, become less viscid, less apt to turn sour, more detergent, more disposed to pass off by urine, and in general more salubrious. They are said to contain an agreeable odoriferous principle, which promotes the vinous fermentation. When slightly boiled or infused in warm water, they increase its spirituousity.

Laws relating to Hops. By 9 Anne, cap. 121. an additional duty of 3d. a pound is laid on all hops imported, over and above all other duties; and hops landed before entry and payment of duty, or without warrant for landing, shall be forfeited and burnt; the ship also shall be forfeited, and the person concerned in importing or landing shall forfeit 5l. a hundred weight; 7 Geo. II. cap. 19. By 9 Anne, cap. 12. there shall be paid a duty of 1d. for every pound of hops grown in Great Britain, and made fit for use, within six months after they are cured and bagged; and hop-grounds are required to be entered on pain of 40s. an acre. Places of curing and keeping are also to be entered, on pain of 50l. which may be visited by an officer at any time without obstruction, under the penalty of 20l. All hops shall, within six weeks after gathering, be brought to such places to be cured and bagged, on pain of 5s. a pound. The rebagging of foreign hops in British bagging for sale or exportation, incurs a forfeiture of 10l. a hundred weight; and defrauding the king of his duty by using twice or oftener the same bag, with the officer's mark upon it, is liable to a penalty of 40l. The removal of hops before they have been bagged and weighed, incurs a penalty of 50l. Concealment of hops subjects to the forfeiture of 20l. and the concealed hops; and any person who shall privately convey away any hops, with intent to defraud the king and owner, shall forfeit 5s. a pound. And the duties are required to be paid within six months after curing, bagging, and weighing, on pain of double duty, two-thirds to the king, and one-third to the informer. No common brewer, &c. shall use any bitter ingredient instead of hops, on pain of 20l. Hops which have paid the duty may be exported to Ireland; but by 6 Geo. II. cap. 1. there shall be no drawback; and by 7 Geo. II. cap. 19. no foreign hops shall be landed in Ireland. Notice of bagging and weighing shall be sent in writing to the officer, on pain of 50l. 6 Geo. cap. 21. And by 14 Geo. III. cap. 68. the officer shall, on pain of 5l. weigh the bags or pockets, and mark on them the true weight or tare, the planter's name and place of abode, and the date of the year in which such hops were grown; and the altering or forging, or obliterating such mark, incurs a forfeiture of 10l.—The owners of hops shall keep at their oasts, &c. just weights and scales, and permit the officer to use them on pain of 20l. 6 Geo. cap. 21. And by 10 Geo. III. cap. 44. a penalty of 100l. is inflicted

for false scales and weights. The owners are allowed to use casks instead of bags, under the same regulations, 6 Geo. cap. 21. If any person shall mix with hope any drug to alter the colour or scent, he shall forfeit 5l. a hundred weight. If any person shall unlawfully and maliciously cut hop binds growing on poles in any plantation, he shall be guilty of felony without benefit of clergy. 6 Geo. II. cap. 37.

HOPE, in *Ethics*, is the desire of some good, attended with a belief of the possibility at least, of obtaining it, and enlivened with joy, greater or less, according to the greater or less probability of our possessing the object of our hope. Alexander, preparing for his Asian expedition, distributed his hereditary dominions among his friends; allotting to some villages, to others boroughs, to others cities; and being asked what he had reserved for himself, replied, Hope.

HOPE, Good, Caps of. See *GOOD HOPE*.

HOPEA, a genus of plants belonging to the polyadelphia class. See *BOTANY INDEX*.

HOPLITES, HOPLITÆ (formed of *ἔπιλον, armour*), in antiquity, were such of the candidates at the Olympic and other sacred games as ran races in armour.

One of the finest pieces of the famous Parrhasius was a painting which represented two hoplites; the one running, and seeming to sweat large drops; the other laying his arms down, as quite spent and out of breath.

HOPLITODROMOS, (formed of *ἔπιλον, armour*; and *δρομος, I run*), in the ancient gymnastic sports, a term applied to such persons as went through those toilsome and robust exercises in complete armour; by which the exercise became much more violent, and the wearing of armour in the time of battle much more easy.

HOPLOMACHI, *Ὀπλομαχοί*, (composed of *ἔπιλον, armour*, and *μαχημαί, I fight*), in antiquity, were a species of gladiators who fought in armour; either completely armed from head to foot, or only with a cask and cuirass.

HOPPER, a vessel in which seed-corn is carried at the time of sowing.

The word is also used for that wooden trough in a mill, into which the corn is put to be ground.

HOR, a mountain, or mountainous tract of Arabia Petraea, situated in that circuit which the Israelites took to the south and south-east of Edom in their way to the borders of Moab: on this mountain Aaron died. The inhabitants were called *Horites*. This tract was also called *Scir*, either from a native Horite, or from Esau, by way of anticipation from his hairy habit of body; whose posterity drove out the Horites.

HORÆ. See *HOURS*.

HORÆA, in antiquity, solemn sacrifices, consisting of fruits, &c. offered in spring, summer, autumn, and winter; that heaven might grant mild and temperate weather. These, according to Meursius, were offered to the goddesses called *Ἵρας*, i. e. *Hours*, who were three in number, attended upon the Sun, presided over the four seasons of the year, and had divine worship paid them at Athens.

HORAPOLLO, or HORUS APOLLO, a grammarian of Panopolis in Egypt, according to Suidas, who first taught at Alexandria, and then at Constantinople

ollo under the reign of Theodosius. There are extant, under his name, two books on the hieroglyphics of the Egyptians: which Aldus first published in Greek in 1505, in folio; and they have often been published since, with a Latin version and notes. It is not certain, however, that the grammarian of Alexandria was the author of these books; they being rather thought to belong to another Horapollon of more ancient date: on which head, see *Fabricius's Bibliotheca Græca*.

HORATII, three Roman brothers, who, under the reign of Tullus Hostilius, fought against the three Curiatii, who belonged to the Alban army. Two of the Horatii were first killed; but the third, by his address, successively slew the three Curiatii, and by this victory rendered the city of Alba subject to the Romans. See ROME.

HORATIUS, surnamed *Cocles* from his losing an eye in combat, was nephew to the consul Horatius Pulvillus, and descended from one of the three brothers who fought against the Curiatii. Porsenna, laying siege to Rome, drove the Romans from Janiculum; and pursued them to the wooden bridge over the Tiber, which joined the city to Janiculum. Largius, Herminius, and Horatius Cocles, sustained the shock of the enemy on the bridge, and prevented their entering the city with the Romans; but Largius and Herminius having passed the bridge, Horatius Cocles was left alone, and repulsed the enemy till the bridge was broken under him: he then threw himself armed into the Tiber, swam across the river, and entered Rome in triumph.

HORATIUS, *Quintus Flaccus*, the most excellent of the Latin poets of the lyric and satirical kind, and the most judicious critic in the reign of Augustus, was the grandson of a freedman, and was born at Venusium 64 B. C. He had the best masters in Rome, after which he completed his education at Athens. Having taken up arms, he embraced the party of Brutus and Cassius, but left his shield at the battle of Philippi. Some time after he gave himself up entirely to the study of polite literature and poetry. His talents soon made him known to Augustus and Mæcenas, who had a particular esteem for him, and loaded him with favours. Horace also contracted a strict friendship with Agrippa, Pollio, Virgil, and all the other great men of his time. He lived without ambition, and led a tranquil and agreeable life with his friends; but was subject to a defluxion in his eyes. He died at the age of 57. There are still extant his Odes, Epistles, Satires, and Art of Poetry; of which there have been a great number of editions. The best are those of the Louvre, in 1642, folio; of Paris 1691, quarto; of Cambridge, 1699; and that with Bentley's emendations, printed at Cambridge in 1711.

HOBD, in *Geography*, is used for a company of wandering people, which have no settled habitation, but stroll about, dwelling in waggons or under tents, to be ready to shift as soon as the herbage, fruit, and the present province, is eaten bare: such are several tribes of the Tartars, particularly those who inhabit beyond the Wolga, in the kingdoms of Astracan and Bulgaria.

A herd consists of 50 or 60 tents, ranged in a circle, and leaving an open place in the middle. The in-

habitants in each herd usually form a military company or troop, the eldest whereof is commonly the captain, and depends on the general or prince of the whole nation.

HORDEUM, BARLEY, a genus of plants belonging to the triandria class; and in the natural method ranking under the 4th order, *Gramina*. See BOTANY *Index*.

HORDICALIA, or **HORDICIDIA**, in antiquity, a religious feast held among the Romans, wherein they sacrificed cattle big with young. This feast fell on April 15th, on which day they sacrificed 30 cows with calf to the goddess Tellus or the Earth; part of them were sacrificed in the temple of Jupiter. The calves taken out of their bellies were burnt to ashes at first by the pontifices, afterwards by the eldest of the vestal virgins.

HOREB, or **OREB**, a mountain of Arabia Petrea, contiguous to and on the south side of Mount Sinai; the scene of many miraculous appearances.

HORESTI (Tacitus), a people of Britain, beyond Solway frith. Now *Esksdale* (Camden).

HORITES, an ancient people, who at the beginning dwelt in the mountains of Seir beyond Jordan (Gen. xiv. 6.). They had princes, and were powerful, even before Esau made a conquest of their country, (*id.* xxxvi. 20—30.). The Horites, the descendants of Seir, and the Edomites, seem afterwards to have been confounded, and to have composed but one people (Deut. ii. 2. xxxiii. 2. and Judg. v. 4.). They dwelt in Arabia Petrea, and Arabia Deserta, to the south-east of the promised land. We find the Hebrew word *חורי*, *Chorim*, which in the book of Genesis is translated *Horites*, to be used in an appellative sense in several other passages of scripture, and to signify nobles, or great and powerful men (1 Kings xxi. 8. 11. and Neh. ii. 16. iv. 14. v. 7. vi. 17. vii. 5. xii. 17. Eccl. x. 17. Isa. xxxiv. 12. Jer. xxvii. 20. xxxix. 6.); and it is very probable that the Greeks derived from hence their *heroes*, in like manner as they derived *Anas*, "a king," from the sons of Anak, the famous giant in Palestine.

HOREHOUND, the name of a plant. See **MAR-RUBIUM**, BOTANY *Index*.

HORIZON, or **HORISON**, in *Geography* and *Astronomy*, a great circle of the sphere, dividing the world into two parts or hemispheres; the one upper and visible, the other lower and hid. The word is pure Greek, *ὁρίζων*, which literally signifies "bounding or terminating the sight;" being formed of *ἴσχω*, *termino*, *definio*, "I bound, I limit;" whence it is also called *finisher*, "finisher." See ASTRONOMY and GEOGRAPHY.

The horizon is either *rational* or *sensible*.

Rational, *true*, or *astronomical HORIZON*, which is also called simply and absolutely *the horizon*, is a great circle, whose plane passes through the centre of the earth, and whose poles are the zenith and nadir. It divides the sphere into two equal parts or hemispheres.

Sensible, *visible*, or *apparent HORIZON*, is a lesser circle of the sphere, which divides the visible part of the sphere from the invisible. Its poles, too, are the zenith and nadir: and consequently the *sensible horizon* is parallel to the *rational*; and it is cut at right angles,

Herd
|
Horizon.

Horizon
H
Horn.

and into two equal parts, by the verticals.—The *sensible horizon* is divided into *eastern* and *western*. The *eastern* or *ortive* horizon, is that part of the horizon wherein the heavenly bodies rise. The *western* or *occidental* horizon, is that wherein the stars set. The altitude or elevation of any point of the sphere, is an arch of a vertical circle intercepted between it and the sensible horizon.

By *sensible horizon* is also frequently meant a circle, which determines the segment of the surface of the earth, over which the eye can reach; called also the *physical horizon*. In this sense we say, a spacious *horizon*, a narrow scanty *horizon*.

HORIZONTAL, something that relates to the horizon, is taken in the horizon, or on a level with the horizon.—We say, a *horizontal plane*, *horizontal line*, &c.

HORIZONTAL Dial, is that drawn on a parallel to the horizon: having its gnomon, or style, elevated according to the altitude of the pole of the place for which it is designed. Horizontal dials are, of all others, the most simple and easy. The manner of describing them, see under the article **DIAL**.

HORIZONTAL Line, in *Perspective*, is a right line drawn through the principal point, parallel to the horizon: or, it is the intersection of the horizontal and perspective planes. See **PERSPECTIVE**.

HORIZONTAL Plane, is that which is parallel to the horizon of the place, or nothing inclined thereto.

The business of levelling is to find whether two points be in the horizontal plane; or how much the deviation is. See **LEVELLING**.

HORIZONTAL Plane, in *Perspective*, is a plane parallel to the horizon, passing through the eye, and cutting the perspective plane at right angles.

HORIZONTAL Projection. See **GEOGRAPHY Index**.

HORIZONTAL Range, or *Level Range*, of a piece of ordnance, is the line it describes, when directed parallel to the horizon or horizontal line. See **GUNNERY**, *passim*.

HORIZONTAL Moon. See **MOON**, **ASTRONOMY Index**.

HORIZONTAL Speculum. See **SPECULUM**.

HORMINUM, **CLART**, a genus of plants belonging to the didynamia class; and in the natural method ranking under the 5th order, *Vorticillata*. See **BOTANY Index**.

HORN, in *Physiology*, a hard substance growing on the heads of divers animals, particularly the cloven-footed quadrupeds; and serving them both as weapons of offence and defence.

The horn of animals is of the same nature as their gelatinous matter; and is only that matter charged with a less quantity of water, and a larger quantity of earth, and sufficiently condensed to have a firm and solid consistence. By digesting horn with water in Papin's digester, it may be entirely converted into jelly.

Horn is a perfectly animalised matter, and furnishes in distillation the same principles as all animal matters; that is, at first a pure phlegm, with a degree of heat not exceeding that of boiling water; then a volatile alkaline spirit, which becomes more and more penetrating and strong; a fetid, light, and thin oil; a concrete volatile salt, which forms ramifications upon the sides of the receiver; much air; fetid oil, which becomes more and more black and thick; and lastly, it

leaves in the retort a considerable quantity of almost incombustible coal, from which, after its incineration, scarcely any fixed alkali can be obtained.

Animal oil, and particularly that which is drawn first in the distillation of horn, is susceptible of acquiring great thickness and volatility by repeated distillations, and is then called the *oil of dippel*.

The horns of stags, and of other animals of that kind, are the most proper to furnish the animal oil to be rectified in the manner of dippel; because they yield the largest quantity. These horns also differ from the horns of other animals in this, that they contain a larger quantity of the same kind of earth which is in bones; hence they seem to possess an intermediate nature between horns and bones.

Hart's-HORN. See **HART'S-HORN**.

HORNS make a considerable article in the arts and manufactures. Bullocks horns, softened by the fire, serve to make lanterns, combs, knives, ink-horns, tobacco-boxes, &c.

Dyeing of Horn.—Black is performed by steeping brass in aquafortis till it be returned green: with this the horn is to be washed once or twice, and then put into a warmed decoction of logwood and water. Green is begun by boiling it, &c. in alum-water; then with verdigrise, ammoniac, and white-wine vinegar; keeping it hot therein till sufficiently green. Red is begun by boiling it in alum-water; and finished by decoction in a liquor compounded of quick-lime steeped in rain water, strained, and to every pint an ounce of Brazil-wood added. In this decoction the bone, &c. is to be boiled till sufficiently red.

Dr Lewis informs us that horns receive a deep black stain from solution of silver. It ought to be diluted to such a degree as not sensibly to corrode the subject; and applied two or three times, if necessary, at considerable intervals, the matter being exposed as much as possible to the sun, to hasten the appearance and deepening of the colour.

Dyeing or staining Horn to imitate Tortoise-shell.—The horn to be dyed must be first pressed into proper plates, scales, or other flat form; and the following mixture prepared. Take of quick-lime two parts, and of litharge one part; temper them together to the consistence of a soft paste with soap-ley. Put this paste over all the parts of the horn, except such as are proper to be left transparent, in order to give it a nearer resemblance of the tortoise-shell. The horn must remain in this manner covered with the paste till it be thoroughly dry; when, the paste being brushed off, the horn will be found partly opaque and partly transparent, in the manner of tortoise-shell; and when put over a foil, of the kind of latten called *assidue*, will be scarcely distinguishable from it. It requires some degree of fancy and judgement to dispose of the paste in such a manner as to form a variety of transparent parts, of different magnitudes and figures, to look like the effect of nature: and it will be an improvement to add semitransparent parts; which may be done by mixing whitening with some of the paste to weaken its operation in particular places; by which spots of a reddish brown will be produced, which if properly interspersed, especially on the edges of the dark parts, will greatly increase both the beauty of the work, and its similitude with the real tortoise-shell.

Horn.

Horn.

HORN is also a sort of musical instrument of the wind kind; chiefly used in hunting, to animate and bring together the dogs and the hunters. The term anciently was, *wind a horn*, all horns being in those times compassed; but since straight horns are come in fashion, they say *blow a horn*, and sometimes *sound a horn*.—There are various lessons on a horn; as the recheat, double recheat, royal recheat, running or farewell recheat, &c. See **RECHEAT**.

The *French horn* is no other than a wreathed or contorted trumpet. It labours under the same defects as the trumpet itself; but these have of late been so palliated, as to require no particular selection of keys for this instrument. In the beginning of the year 1773, a foreigner, named Spandau, played in a concert at the opera-house a concerto, part whereof was in the key of C, with the minor-third; in the performance of which all the intervals seemed to be as perfect as in any wind-instrument. This improvement was effected by putting his right hand into the bottom or bell of the instrument, and tempering the sounds by the application of his fingers to different parts of the tube.

The Hebrews made use of horns, formed of rams horns, to proclaim the jubilee; whence the name **JUBILEE**.

Cape-HORN. See *Terra del Fuoco*.

HORN-Beam. See **CARPINUS**, **BOTANY Index**.

HORN-Bill. See **BUCEROS**, **ORNITHOLOGY Index**.

HORN-Blende, a species of mineral. See **MINERALOGY Index**.

Human Horns. In Dr Charles Leigh's natural history of Lancashire, Cheshire, and the Peak in Derbyshire, is the print of a woman with two horns on her head. When she was 28 years of age an excrescence grew upon her head like a wen, which continued 30 years, and then grew into two horns. After four years she cast them, and in their place grew two others. After four years she cast these also; and the horns which were on her head in 1668 (the time when the account was written) were then loose. Her picture and one of her horns are in Ashmole's museum. In the university library at Edinburgh is preserved a horn which was cut from the head of Elizabeth Love, in the 50th year of her age. It grew three inches above the ear, and was growing seven years.

Horn Distemper, a disease incident to horned cattle, affecting the internal substance of the horn commonly called the pith, which it insensibly wastes, and leaves the horn hollow. The pith is a spongy bone, the cells of which are filled with an unctuous matter. It is furnished with a great number of small blood vessels, is overspread with a thin membrane, and appears to be united by sutures with the bones of the head. According to an account of this distemper, published by Dr Tofts in the *Memoirs of the American Academy*, vol. i. the said spongy bone is sometimes partly, and sometimes entirely wasted. The horn loses its natural heat, and a degree of coldness is felt upon handling it. The distemper, however, is seldom suspected without a particular acquaintance with the other symptoms, which are a dulness in the countenance of the beast, a sluggishness in moving, a failure of appetite, an inclination to lie down, and, when accompanied with an inflammation of brain, a giddiness and frequent tossing of the head. The limbs are sometimes affected with stiffness, as in a

rheumatism; in cows the milk often fails, the udder is hard, and in almost all cases there is a sudden wasting of the flesh. As soon as the distemper is discovered, an opening into the diseased horn should be immediately made; which may be done with a gimlet of a moderate size, in such a part of the horn as is most favourable for the discharge. It is recommended as most prudent to bore at first two or three inches above the head. If it is found hollow, and the gimlet passes through to the opposite side, and no blood discharges from the aperture, it may be best to bore still lower, and as near the head as it shall be judged that the hollowness extends. This opening is affirmed to be a necessary measure, and often gives immediate relief. Care must be taken to keep it clear, as it is apt to be clogged by a thin fluid that gradually oozes out and fills up the passage. Some have practised sawing off the horn; but, according to the best observations, it succeeds no better than boring. From the cases Dr Tofts has seen, he is led to conclude that injections are in general unnecessary; that, when the distemper is early discovered, no more is required than a proper opening into the horn, keeping it sufficiently clear for the admission of fresh air, the removal of the compression, and the discharge of floating matter. But when the distemper has reached the brain, so as to produce great inflammation, it is much to be doubted whether any method of cure will succeed.

HORN-Fish, *Gar-fish*, or *Sea-needle*. See **ESOX**, **ICHTHOLOGY Index**.

HORN-Work, in fortification, an outwork of two demi-bastions joined by a curtain. See **FORTIFICATION**.

HORNBY, a town of England, in Lancashire, seated on a branch of the river Lune, with a handsome parochial chapel. The inhabitants amounted to 420 in 1811, and are chiefly employed in the cotton manufacture. W. Long. 2. 33. N. Lat. 54. 3.

HORN-CASTLE, a town of England, in Lincolnshire. It had a castle, as the name imports; from the architecture of which, and the Roman coins that are sometimes dug up here, it is thought to have been a camp or station of the Romans. The town is well built, and is almost surrounded with water. It is a signiory of 13 lordships, in which are several chapels. Horn-castle contained in 1811, 2622 inhabitants, who are principally occupied in the manufacture of leather. It has a market on Saturdays, and fairs in June and August.

HORNDON, a town of Essex in England. It stands near a rivulet, that at a small distance from hence falls into the Thames. Population 378 in 1811. E. Long. 0. 30. N. Lat. 51. 20.

HORNE, GEORGE, an English prelate of great eminence, was born in the vicinity of Maidstone, in the county of Kent, in the year 1730. His father was rector of Otham, and having for some time acted in the capacity of a tutor at Oxford, was well qualified to superintend the education of his son George. However, that he might not be spoiled by too long a residence at home, he was, by the advice of a friend, sent to Maidstone school at the age of 13, where he continued under an eminent teacher for two years, and acquired some knowledge of oriental literature, particularly the Hebrew, and went to Oxford in his 15th year. Here

Horn
Horne.

Horne. he indefatigably laboured to store his mind with almost every branch of useful learning, and resolved to make polite literature subservient to the knowledge and illustration of the Scriptures. He studied the Hebrew more attentively, and was wisely exhorted to abandon the method of Buxtorf, so encumbered with that load of rubbish, the masoretic punctuation. The rectitude of his conduct, and the vivacity of his conversation, gained him the esteem of every person with whom he was acquainted. In the year 1749 he was made B. A. and next year was elected to a fellowship in Magdalen college, without any solicitation upon his part.

About this time he became a proselyte to what are called the mysteries of *Hutchinsonianism*, chiefly through the influence of Mr William Jones. His mind, at the age of 19, was completely fettered by those doctrines, believing that it was the design of Sir Isaac Newton and Dr Clarke, to subvert the theology of the Scriptures, and introduce the stoical *anima mundi* into the place of the God of the universe! Under the influence of such an infatuated whim, it is not astonishing that he should endeavour to discredit the system of Newton. He obtained the degree of M. A. in the year 1752, when he engaged in a controversy on the subject of the cherubim, in the Gentleman's Magazine, subscribing himself *Ingenuus*. With a view to recommend the writings of Hutchinson, he published "A fair, candid, and impartial state of the case between Sir Isaac Newton and Mr Hutchinson; in which is shewn, how far a system of physics is capable of mathematical demonstration; how far Sir Isaac's, as such a system, has that demonstration; and consequently, what regard Mr Hutchinson's claim may deserve to have paid it." In the year 1753 Mr Horne entered into holy orders, and acquired high reputation as a public speaker, as his compositions were excellent, and his elocution graceful. While preaching before the university, he introduced some of his peculiar notions, which again led him into controversy. A piece made its appearance, entitled "A word to the Hutchinsonians; or, remarks on three extraordinary sermons, lately preached before the university of Oxford, by Dr Patten, Mr Wetherell, and Mr Horne." To this our author replied in his "Apology for certain gentlemen in the university of Oxford, aspersed in a late anonymous pamphlet," &c. The vindication of the hint to the Hutchinsonians, was supposed to be the production of Dr Kennicott, who became afterwards so famous for his labours in collating Hebrew manuscripts, and his valuable edition of the Hebrew Bible. He (Mr Horne) was chosen proctor of the university in 1758, and on the honourable termination of his authority was created B. D. When Mr (afterwards Dr) Kennicott, gave the world proposals for collating the text of the Hebrew Bible, for the purpose of correcting the original, and preparing for a new translation, Mr Horne was very much alarmed. He falsely apprehended that the adoption of such a measure would overwhelm the sacred text with licentious criticism; on which account he published, in 1760, "A view of Mr Kennicott's method of correcting the Hebrew text, with three queries formed thereon, and humbly submitted to the consideration of the learned and Christian world." But an acquaintance which thus began in hostility was converted afterwards into

genuine friendship, which continued through the whole of life.

Horne. In 1764, Mr Horne was created D. D. although as yet advanced to no conspicuous station. On the death of Dr Jenner, the president of Magdalen college, Dr Horne was appointed to succeed him in a post at once honourable and valuable, in the beginning of 1768, after which we are informed that he exchanged a single for a married life. Next year he published "Considerations on the life and death of St John the Baptist, being the substance of several sermons preached by him before the university." In 1771, he was chosen chaplain in ordinary to his majesty, which he held for ten years. In 1772, when a number of clergymen had formed the resolution of petitioning parliament for relief as to the subscribing the liturgy and thirty-nine articles, Dr Horne determined, if possible, to defeat their object, for which purpose he published "Considerations on the projected reformation of the church of England, in a letter to Lord North."

He now set about the finishing of his greatest work, which had occupied his attention for almost 20 years. This was his "Commentary on the Book of Psalms," which appeared in 1776, in 2 vols quarto. It exhibits profound erudition, a great genius, and fervent piety; and is perused with much pleasure and advantage by every judge of merit. In the same year he was chosen vice-chancellor of the university, which he held to the latter end of the year 1780. On the publication of Dr Adam Smith's letter, containing an account of the death of Mr David Hume, Dr Horne, in the year 1777, publicly animadverted upon it, in "A letter to Adam Smith, L. L. D. on the life, death, and philosophy of his friend David Hume, Esq. by one of the people called Christians." In this work he exposes the absurdities of the Scotch philosopher's performance; to the contempt of the religious world, with clear and conclusive reasoning, and keen but good-humoured irony. In 1779, Dr Horne published "Discourses on various subjects and occasions," in two volumes octavo, which have procured the approbation of all descriptions of readers.

As vice-chancellor of the university he became acquainted with Lord North, to whose interest, joined with that of Lord Hawkesbury, he was indebted, in 1781, for the deanery of Canterbury. His time was now divided between this city and Oxford, and the conscientious discharge of every part of his complex duty made him universally beloved. In 1784 he published letters on infidelity, similar to his reply to Dr Adam Smith. The books against which he levelled his ridicule are, "An apology for the life and writings of David Hume, Esq.;" Hume's "Dialogues on natural religion;" An essay on suicide by the same author, and a treatise entitled "Doubts of the Infidels." In the year 1790, when Dr Bagot was translated to the see of St Asaph, Dr Horne was appointed to succeed him in the see of Norwich. His last literary labours were "Observations on the case of the Protestant dissenters with reference to the corporation and test acts," 1790; and "A charge intended to have been delivered to the clergy of the diocese of Norwich," at his first visitation, 1791. When he was raised to the episcopal dignity, his health, always delicate, began rapidly to decline;

Horne decline; but from the waters of Bath he received great relief, to which place he repaired a third time in the harvest of 1791. On his way he was seized with a stroke of the palsy, and after languishing for a few weeks, he died at Bath on the 17th of January 1792, in the 62d year of his age.

Hornsey. He was powerfully animated in his last moments by those hopes which spring from the promises of the gospel, and the inexpressible satisfaction of a well-spent life. His erudition was extensive, his piety sincere, and his whole life exemplary. His charity, both of a public and private nature, was very extensive, and if not in debt at the end of the year, he was perfectly satisfied. His posthumous works are, vols iii. and iv. of "Discourses on several subjects and occasions;" a volume of sermons; and "Cautions to the readers of Mr Law."

HORNERS, those people whose business it is to prepare various utensils of the horns of cattle. The horners were a very ancient and considerable fraternity in the city of London some hundred years ago. In the reign of Edward II. they complained to parliament, that by foreigners buying up the horns in England, they were in danger of being ruined, and this business lost to the nation. For this reason was made the statute 6 Edw. IV. by which the sale of horns to foreigners (except such as the said horners refused) was prohibited; and the wardens had power granted them to search all the markets in London, and twenty-four miles round, and to inspect Sturbridge and Ely fairs, to prevent such practices, and to purchase horns at stated prices. But on plausible pretences this law was repealed in the reign of James I. and thereupon the old evil revived. The horners again applied to parliament, and King Edward's statute was renewed (excepting as to the inspection of the fairs), and still remains in force. The importation of unwrought horns into this country is also prohibited. In 1750, there were exported to Holland 514,500 lantern leaves, besides powder flasks. There was formerly a duty of 20 shillings a thousand, under which in 1682 were exported 76,650; but in the reign of George I. this duty was taken off, and these and all other manufactures made of horns may be exported free. The present company of horners was incorporated January 12. 1638; and consists of a master, two wardens, and nine assistants, without livery or hall. They have a warehouse in Spitalfields, to which the horns are sent as brought from town and country-markets, and thence regularly divided, the widows and orphans of deceased members having equal shares.

HORNET, a species of wasp. See **VESPA**, **ENTOMOLOGY Index**.

HORNING, in *Scots Law*, a writing issuing from the signet, in his majesty's name, at the instance of a creditor against his debtor, commanding him to pay or perform within a certain time, under pain of being declared rebel, and by a caption put in prison.

HORNSEY, a town in Yorkshire, 188 miles north from London, and 15 from Hull. It is almost surrounded by a small arm of the sea; and the church having a high steeple, is a noted sea-mark. Not many years ago there was a street here called *Hornsey-beck*, which was washed away by the sea, except a house or two. The inhabitants amounted to 704 in 1811.

HORNSEY, a town of Middlesex, five miles north of London. It is a long straggling place, situated in a low valley, but extremely pleasant, having the new river winding through it. Its church, of which Highgate is a hamlet, is supposed to be built with the stones that came from Lodge-Hill, the bishop of London's hunting-seat in his park here; it having been his manor from the most ancient times. About a mile nearer this is a coppice of young trees, called *Hornsey-wood*, at the entrance of which is a public-house, which commands a fine prospect, and is a great resort of the citizens of London. In 1811, Hornsey contained 3349 inhabitants.

HORNPIPE, a common instrument of music in Wales, consisting of a wooden pipe, with holes at stated distances, and a horn at each end: the one to collect the wind blown into it by the mouth, and the other to carry off the sounds as modulated by the performer.

HORNPIPE is also the name of an English air, probably derived from the above instrument. The measure of this air is triple time, with six crotchets in a bar; four of which are to be beat with the hand down and two up.

HOROGRAPHY, the art of making or constructing dials; called also dialling, horologiography, gnomonica, sciatherica, photosciatherica, &c.

HOROLOGIUM, ὁρολογιον, (composed of *hora*, *hora*, "time, hour," and *logos*, "speech, discourse,") a common name among ancient writers for any instrument or machine for measuring the hours; see **CHRONOMETER**.—Such are our clocks, watches, sun-dials, &c. See **CLOCK**, **WATCH**, **DIAL**, and **CLEPSYDRA**.

Modern inventions, and gradual improvements, have given birth to some new terms that come properly under this head, and annexed new meanings to others totally different from what they had originally. All chronometers that announced the hour by striking on a bell, were called *clocks*: thus, we read of pocket-clocks, though nothing could seem more absurd than to suppose that a clock, according to the modern idea, should be carried in the pocket. In like manner, all clocks that did not strike the hour were called *watches* or *time-pieces*; and the different parts of a striking clock were distinguished by the watch-part and the clock-part; the former meaning that part which measures the time, and the latter the part which proclaims the hours. In the report of Sir Isaac Newton to the house of commons, anno 1713, relative to the longitude act, he states the difficulties of ascertaining the longitude by means of a watch: yet it is obvious, from several circumstances, that his remarks were directly to be understood of a time-piece regulated by a pendulum; for his objections are founded on the known properties of the pendulum, some of which differ essentially from the properties of the balance and spring. It is also to be remembered, that all the attempts of Huygens for finding the longitude were by means of pendulum clocks that did not strike the hour, and consequently, according to the language of the times, were called *watches*. At this time such machines for measuring time as are fixed in their place are called *clocks*, if they strike the hour: if they do not strike the hour, they are called *time-pieces*; and when constructed with more care, for a more accurate measure of time, they

Hornsey
Horologium

Horologium
Horse.

are called *regulators*. Some artists of late have affected to call such watches as were constructed for astronomical and nautical observations by the name of *time-pieces*, probably to intimate that they possess the advantages of those constructed with a pendulum.

Mr John Harrison first gave the name of *time-keeper* to his watch, for the performance of which he received from parliament the sum of 20,000*l*. See LONGITUDE.

For the account of the principles of this machine, see TIME-KEEPER. And for the chief improvements that have been made for the more accurate measure of time, see PALLETS, PENDULUM, and SCAPEMENT.

HOROPTER, in *Optics*, is a right line drawn through the point where the two optic axes meet, parallel to that which joins the centres of the two eyes, or the two pupils.

HOROSCOPE, in *Astrology*, the degree or point of the heavens rising above the eastern point of the horizon at any given time when a prediction is to be made of a future event: as, the fortune of a person then born, the success of a design then laid, the weather, &c. The word is composed of *hora, hora*, "hour," and the verb *exornis, video*, "I behold."

Such was at one time the infatuation concerning horoscopes, that Albertus Magnus, Cardan, and others, are said to have had the temerity to draw that of Jesus Christ.

HOROSCOPE is also used for a scheme or figure of the twelve houses, i. e. the twelve signs of the zodiac, wherein is marked the disposition of the heavens for any given time. Thus we say, to draw a horoscope, construct a horoscope, &c. We call it, more peculiarly, *calculating a nativity*, when the life and fortune of a person are the subject of the prediction; for they draw horoscopes of cities, great enterprises, &c. See HOUSE.

HOROSCOPY. See DIVINATION, N^o 2.

HORREA, in Roman antiquity, were public magazines of corn and salt-beef, out of which the soldiers were furnished on their march in the military roads of the empire. *Horrea* was also the name which they gave to their granaries.

HORROX, JEREMIAH, an eminent English astronomer in the 17th century, was born at Texteth near Liverpool in Lancashire in 1619. He died, to the great loss of that science and of the world, in the 23d year of his age, after he had just finished his *Venus in Sole visa*; which, with some other works, were published by Dr Wallis, in quarto.

HORROR, strictly signifies such an excess of fear as makes a person tremble. See FEAR, FRIGHT, and TERROR. In medicine, it denotes a shivering and shaking of the whole body, coming by fits. It is common at the beginning of all fevers, but is particularly remarkable in those of the intermittent kind.

HORROR of a Vacuum, was an imaginary principle among the ancient philosophers, to which they ascribed the ascent of water in pumps, and other similar phenomena, which are now known to be occasioned by the weight of the air.

HORSE. See EQUUS, MAMMALIA *Indes*.

Horses were very rare in Judæa till Solomon's time. Before him we find no horsemen mentioned in the armies of Israel. David having won a great battle against

Hadadezer king of Shobah (2 Sam. viii. 4. 5.), took 1700 horses, and lamed all belonging to the chariots of war, reserving only 100 chariots. The judges and princes of Israel used generally to ride on mules or asses. After David's time, horses were more common in the country of Judah, &c. Solomon is the first king of Judah who had a great number of horses, and he kept them rather for pomp than for war; for we do not read that he made any military expeditions. He had, says the Scripture (1 Kings iv. 26.), 40,000 stalls of horses for his chariots, and 12,000 horsemen distributed in his fortified places (1 Kings x. 26.). He had his horses from Egypt (ibid. ver. 28, 29.); and there was not a set which did not cost him more than 600 shekels, which make of our money about 90*l*. Moses had forbidden the king of the Hebrews to keep a great number of horses (Deut. xvii. 16.), lest at any time he should be inclined to carry the people back into Egypt.

We read in the second book of Kings (xxiii. 17.), that Josiah took away the horses which the kings of Judah his predecessors had consecrated to the sun. We know the sun was worshipped over all the east, and that the horse, the swiftest of tame beasts, was consecrated to this deity, who was represented as riding in a chariot drawn by the most beautiful and swiftest horses in the world, and performing every day his journey from east to west, in order to communicate his light to mankind. Xenophon describes a solemn sacrifice of horses, which was made with ceremony to the sun: they were all the finest steeds, and were led with a white chariot, crowned, and consecrated to the same god. We may believe that the horses which Josiah removed out of the court of the temple, were appointed for the like sacrifices. The rabbins inform us, that these horses were every morning put to the chariots dedicated to the sun, whereof there is mention made in the same book; and that the king, or some of his officers, got up and rode to meet the sun in its rising, as far as from the eastern gate of the temple to the suburbs of Jerusalem. Others are of opinion, that the horses mentioned in the book of Kings were of wood, stone, or metal, erected in the temple in honour of the sun: Others, that they were horses which none were permitted to ride or fasten to the yoke, but were free, and left to themselves, like those which Julius Cæsar let loose and set at liberty after his passage of the Rubicon.

Horses were used both amongst the Greeks and Romans in war, but were not originally very numerous; for as each horseman provided his own horse, few would be able to bear the expence. Horses for a considerable time were managed by the voice alone, or by a switch, without bridle, saddle, or stirrups. Their harness was skins of beasts, or sometimes cloth. Both horses and men amongst the Greeks underwent a severe probation before their admission into the cavalry.—Horse-races were common amongst the Greeks and Romans, and the place where they ran or breathed their coursers was called *hippodromus*.

Management of a Horse upon and after a Journey. See that his shoes be not too strait, or press his feet, but be exactly shaped; and let him be shod some days before you begin a journey, that they may be settled to his feet.

Observe that he is furnished with a bitt proper for him,

Horse. him, and by no means too heavy, which may incline
 him to carry low, or to rest upon the hand when he
 grows weary, which horsemen call *making use of his*
fifth leg.

orta.
ict.

The mouth of the bitt should rest upon his bars
 about half a finger's-breadth from his tusches, so as not
 to make him frumple his lips; the curb should rest in
 the hollow of his beard a little above the chin; and if
 it gall him, you must defend the place with a piece of
 buff or other soft leather.

Take notice that the saddle do not rest upon his
 withers, reins, or back-bone, and that one part of it do
 not press his back more than another.

Some riders gall a horse's sides below the saddle with
 their stirrup-leathers, especially if he be lean; to hinder
 it, you should fix a leather strap between the points
 of the fore and hind-bows of the saddle, and make the
 stirrup-leather pass over them.

Begin your journey with short marches, especially
 if your horse has not been exercised for a long time;
 suffer him to stale as often as you find him inclined:
 and not only so, but invite him to it; but do not ex-
 cite your mares to stale, because their vigour will be
 thereby diminished.

It is advisable to ride very softly, for a quarter or
 half an hour before you arrive at the inn, that the
 horse not being too warm, nor out of breath, when
 put into the stable, you may unbridle him: but if your
 business obliges you to put on sharply, you must then
 (the weather being warm) let him be walked in a man's
 hand, that he may cool by degrees; otherwise, if it be
 very cold, let him be covered with cloths, and walked
 up and down in some place free from wind; but in
 case you have not the conveniency of a sheltered walk,
 stable him forthwith, and let his whole body be rubbed
 and dried with straw.

Although some people will have their horses legs
 rubbed down with straw as soon as they are brought
 into the stable, thinking to supple them by that
 means; yet it is one of the greatest errors that can be
 committed, and produces no other effects than to draw
 down into the legs those humours that are always stir-
 red up by the fatigue of the journey; not that the
 rubbing of horses legs is to be disallowed; on the con-
 trary, we highly approve of it, only would not have
 it done at their first arrival, but when they are perfectly
 cooled.

Being come to your inn, as soon as your horse is
 partly dried, and ceases to beat in the flanks, let him
 be unbridled, his bitt washed, cleansed, and wiped, and
 let him eat his hay at pleasure.

If your horse be very dry, and you have not given
 him water on the road, give him oats washed in good
 mild ale.

The dust and sand will sometimes so dry the tongues
 and mouths of horses, that they lose their appetites:
 in such case, give them bran well moistened with wa-
 ter to cool and refresh their mouths; or wash their
 mouths and tongue with a wet sponge, to oblige them
 to eat.

The foregoing directions are to be observed after
 moderate riding; but if you have rode excessively hard,
 unsaddle your horse, and scrape off the sweat with a
 sweating-knife, or scraper, holding it with both hands,
 and going always with the hair; then rub his head and

ears with a large hair-cloth, wipe him also between the
 fore legs and hind legs; in the meanwhile, his body
 should be rubbed all over with straw, especially under
 his belly and beneath the saddle, till he is thoroughly
 dry.

Horse.

That done, set on the saddle again; cover him; and
 if you have a warm place, let him be gently led up and
 down in it for a quarter of an hour; but if not, let him
 dry where he stands.

Or you may unsaddle him immediately; scrape off
 the sweat; let the ostler take a little vinegar in his
 mouth and squirt it into the horse's; then rub his
 head, between the fore and hind legs, and his whole
 body, till he is pretty dry; let him not drink till he is
 thoroughly cool, and has eaten a few oats; for many,
 by drinking too soon, have been spoiled. Set the
 saddle in the sun or by a fire, in order to dry the
 pannels.

When horses are arrived at an inn, a man should,
 before they are unbridled, lift up their feet, to see
 whether they want any of their shoes, or if those they
 have do not rest upon their sides; afterwards he should
 pick and clear them of the earth and gravel which may
 be got betwixt their shoes and soles.

If you water them abroad, upon their return from
 the river cause their feet to be stepped with cow-
 dung, which will ease the pain therein; and if it be in
 the evening, let the dung continue in their feet all
 night, to keep them soft and in good condition; but if
 your horse have brittle feet, it will be requisite to anoint
 the fore feet, at the on-setting of the hoofs, with but-
 ter, oil, or hog's grease, before you water him in the
 morning, and in dry weather they should be also greased
 at noon.

Many horses, as soon as unbridled, instead of eat-
 ing, lay themselves down to rest, by reason of the
 great pain they have in their feet, so that a man is apt
 to think them sick: but if he looks to their eyes, he
 will see they are lively and good; and if he offers them
 meat as they are lying, they will eat it very willingly;
 yet if he handles their feet, he will find them extreme-
 ly hot, which discovers their suffering in that part.
 You must therefore see if their shoes do not rest upon
 their soles, which is somewhat difficult to be certainly
 known without unshoeing them; but if you take off
 their shoes, then look to the inside of them, and you
 may perceive that those parts which rest upon the
 soles are more smooth and shining than the others;
 in this case you are to pare their feet in those parts,
 and fix on their shoes again, anointing the hoofs, and
 stopping the soles with scalding hot black pitch or
 tar.

After a long day's journey, at night feel your horse's
 back, if he be pinched, galled, or swelled (if you do
 not immediately discover it, perhaps you may after sup-
 per), there is nothing better than to rub it with good
 brandy and the white of an egg. If the galls are be-
 tween the legs, use the same remedy; but if the ostler
 rubs him well between the legs, he will seldom be gal-
 led in that part.

In order to preserve horses after travel, take these
 few useful instructions. When you are arrived from a
 journey, immediately draw the two heel-nails of the
 fore feet; and, if it be a large shoe, then four: two
 or three days after, you may blood him in the neck,

and.

Horse.

and feed him for 10 or 12 days only with wet bran, without giving him any oats; but keep him well littered.

The reason why you are to draw the heel-nails, is because the heels are apt to swell, and if they are not thus eased, the shoes would press and straiten them too much: it is also advisable to stop them with cow-dung for a while; but do not take the shoes off, nor pare the feet, because the humours are drawn down by that means.

The following bath will be very serviceable for preserving your horse's legs. Take the dung of a cow or ox, and make it thin with vinegar, so as to be of the consistence of thick broth; and having added a handful of small salt, rub his fore legs from the knees, and the hind legs from the gambrels, chafing them well with and against the hair, that the remedy may sink in and stick to those parts, that they may be all covered over with it. Thus leave the horse till morning, not wetting his legs, but giving him his water that evening in a pail; next-morning lead him to the river, or wash his legs in well water, which is very good, and will keep them from swelling.

Those persons, who, to recover their horses feet, make a hole in them, which they fill with moistened cow dung, and keep it in their fore feet during the space of a month, do very ill; because, though the continual moisture that issues from the dung occasions the growing of the hoof, yet it dries and shrinks it so excessively when out of that place, that it splits and breaks like glass, and the foot immediately straitens. For it is certain, that cow-dung (contrary to the opinion of many people) spoils a horse's hoof: it does indeed moisten the sole, but it dries up the hoof, which is of a different nature from it. In order, therefore, to recover a horse's feet, instead of cow-dung, fill a hole with blue wet clay, and make him keep his fore-feet in it for a month.

Most horses that are fatigued or over-rid, and made lean by long journeys, have their flanks altered without being pury, especially vigorous horses that have worked too violently.

There is no method better to recover them, than to give each of them in the morning half a pound of honey very well mingled with scalded bran; and when they readily eat the half pound, give them the next time a whole one, and afterwards two pounds, every day, continuing this course till your horses are empty, and purge kindly with it; but as soon as you perceive that their purging ceases, forbear to give them any more honey.

You may administer powder of liquorice in the scalded bran for a considerable time; and to cool their blood, it will not be improper to let them have three or four glysters.

In case the horse be very lean, it is expedient to give him some wet bran, over and above his proportion of oats; and grass is also extraordinary beneficial, if he be not pury.

If it be a mare, put her to a horse; and if she never had a foal before, it will enlarge her belly.

Sometimes excessive feeding may do horses more harm than good, by rendering them subject to the farcy. You should therefore be cautious in giving

them too great a quantity at a time, and take a little blood from them now and then.

When a horse begins to drink water heartily, it is a certain sign that he will recover in a short time. As to the method of giving him water during a journey, observe the following rules:

All the while you are upon a journey, let your horse drink of the first good water you come to, after seven o'clock in the morning if it be in summer-time, and after nine or ten in winter.

That is accounted good water which is neither too quick and piercing, nor too muddy and stinking.

This is to be done, unless you would have him gallop a long time after drinking; for if so, you must forbear.

Though it is the custom in England to run and gallop horses after drinking, which we call *watering-courses*, to bring them (as they say) into wind; yet says M. de Solleysel, it is the most pernicious practice that can be imagined for horses, by which many are rendered pury.

While a horse is drinking, draw up his head five or six times, making him move a little between every draught; and notwithstanding he be warm, and sweat very much, yet if he is not quite out of breath, and you have still four or five miles to ride, he will be better after drinking a little, than if he had drank none at all: it is true, indeed, that if the horse is very warm, you should, at coming out of the water, redouble your pace, to make him go at a gentle trot, to warm the water in his belly.

You ought to let him drink after this manner during the whole time of your journey; because, if when you happen to bait he be hot or sweaty, you must not let him drink for a long time, as it would endanger his life; and when his bridle is taken off, his excessive thirst will binder him from eating, so that he will not offer to touch his meat for an hour or two, which perhaps your occasion will not allow you for a baiting time, and not to have any food will render him unfit for travel.

If you meet with any ford before you come to your inn, ride the horse through it two or three times, but not up to his belly: this will not only cleanse his legs, but the coldness of the water will bind up the humours, and prevent them from descending.

If your horse has been very warm, and you have not had the conveniency of watering him upon the road, he will, when unbridled, eat but very little; therefore he should have his oats given him washed in ale or beer, or only some of them, if you intend to feed him again after he has drank.

Some are of opinion, that horses are often spoiled by giving them oats before their water; because they say the water makes the oats pass too soon, and out of the stomach undigested. But M. de Solleysel affirms, that though it be the common custom not to do it till after, yet it is proper to feed with oats both before and after, especially if the horse be warm, and has been hard rode; for he will be a great deal the better for it, and in no danger of becoming sick.

Breeding of HORSES. When the stallion is chosen, *Buffon's* and all the mares intended for him are collected together, there must be another stone horse, to discover which *Nat. Hist.*

Horse.

Horse.

which of the mares are in heat, and, at the same time, contribute to inflame them. All the mares are to be brought successively to this stone-horse, which should also be inflamed, and suffered frequently to neigh. As he is for leaping every one, such as are not in heat keep him off, whilst those which are so suffer him to approach them. But instead of being allowed to satisfy his impulse, he must be led away, and the real stallion substituted in his stead. This trial is necessary for ascertaining the true time of the mare's heat, especially of those which have not yet had a colt; for with regard to such as have recently foaled, the heat usually begins nine days after their delivery; and on that very day they may be led to the stallion to be covered; and nine days after, by the experiment above mentioned, it may be known whether they are still in heat. If they are, they must be covered a second time; and thus successively every ninth day while their heat continues: for when they are impregnated, their heat abates, and in a few days ceases entirely.

But that every thing may be done easily and conveniently, and at the same time with success and advantage, great attention, expence, and precaution, are requisite. The stud must be fixed in a good soil, and in a suitable place, proportioned to the number of mares and stallions intended to be used. This spot must be divided into several parts, inclosed with rails or ditches well fenced; in the part where the pasture is the richest, the mares in fold, and those with colts by their sides, are to be kept. Those which are not impregnated, or have not yet been covered, are to be separated, and kept with the fillies in another close, where the pasture is less rich, that they may not grow too fat, which would obstruct the progress of generation. Lastly, the young stone colts or geldings are to be kept in the driest part of the fields, and where the ground is most unequal; that by running over the uneven surface, they may acquire a freedom in the motion of their legs and shoulders. This close where the stone colts are kept, must be very carefully separated from the others, lest the young horses break their bounds, and enervate themselves with the mares. If the tract be so large as to allow of dividing each of these closes into two parts, for putting oxen and horses into them alternately, the pasture will last much longer than if continually eaten by horses: the ox improving the fertility, whereas the horse lessens it. In each of these closes should be a pond; standing water being better than running, which often gripes them; and if there are any trees in the ground, they should be left standing, their shade being very agreeable to the horses in great heats; but all stems or stumps should be grubbed up, and all holes levelled, to prevent accidents. In these pastures your horses should feed during the summer; but in the winter the mares should be kept in the stable and fed with hay. The colts also must be housed, and never suffered to feed abroad in winter, except in very fine weather. Stallions that stand in the stable should be fed more with straw than hay; and moderately exercised till covering time, which generally lasts from the beginning of April to the end of June. But during this season they should have no other exercise, and be plentifully fed, but with the same food as usual. Before the stallion is brought to the

VOL. X. Part II.

mare, he should be dressed, as that will greatly increase his ardour. The mare must also be curried, and have no shoes on her hind feet, some of them being ticklish, and will kick the stallion. A person holds the mare by the halter, and two others lead the stallion by long reins; when he is in a proper situation, another assistant carefully directs the yard, pulling aside the mare's tail, as a single hair might hurt him dangerously. It sometimes happens that the stallion does not complete the work of generation, coming from the mare without making any injection; it should therefore be attentively observed, whether, in the last moments of the copulation the dock of the stallion's tail has a vibrating motion; for such a motion always accompanies the emission of the seminal lymph. If he has performed the act, he must on no consideration be suffered to repeat it; but be led away directly to the stable, and there kept two days. For, however able a good stallion may be of covering every day during the three months, it is much better to let him be led to a mare only every other day: his produce will be greater, and he himself less exhausted. During the first seven days, let four different mares be successively brought to him; and the ninth day let the first be again brought, and so successively while they continue in heat; but as soon as the heat of any one is over, a fresh mare is to be put in her place, and covered in her turn every nine days; and as several retain even at the first, second, or third time, it is computed that a stallion, by such management, may, during the three months, cover 15 or 18 mares, and beget 10 or 12 colts. These animals have a very large quantity of the seminal lymph; so that a considerable portion of it is shed during the emission. In the mares likewise is an emission, or rather distillation of the seminal lymph, during the whole time they are horsing; ejecting a viscid whitish lymph, called the *heats*, which ceases on conception. This ichor the Greeks called *hippomanes*; and pretended that philtres might be made of it, one remarkable effect of which was; to render a horse frantic with lust. This *hippomanes* is very different from that found in the secundines of the foal, which M. Daubenton first discovered, and has so accurately described its nature, origin, and situation. The ejection of this liquor is the most certain sign of the mare's heat; but it is also known by the inflation of the lower part of the vulva, by her frequent neighings, and attempts to get to the horses. After being covered, nothing more is requisite than to lead her away to the field. The first foal of a mare is never so strongly formed as the succeeding; so that care should be taken to procure for her, the first time, a larger stallion, that the defect of the growth may be compensated by the largeness of the size. Particular regard should also be had to the difference or congruity of the fashion of the stallion and the mare; in order to correct the faults of the one by the perfections of the other: especially never to make any disproportionate copulations, as of a small horse with a large mare, or a large horse with a small mare; as the produce of such copulation would be small, or badly proportioned. It is by gradations that we must endeavour to arrive at natural beauty; for instance, to give to a mare a little too clumsy, a well-made horse and finely shaped; to a small mare, a horse

Horse.

Horse. a little higher; to a mare which is faulty in her forehead, a horse with an elegant head and noble chest, &c.

It has been observed, that horses fed in dry and light grounds, produce temperate, swift, and vigorous foals, with muscular legs and a hard hoof; while the same bred in marshes and moist pastures have produced foals with a large heavy head, a thick carcass, clumsy legs, bad hoofs, and broad feet. These differences proceed from the air and food, which is easily understood; but what is more difficult to be accounted for, and still more essential than what we have hitherto observed, is, to be continually crossing the breed to prevent a degeneracy.

In coupling of horses, the colour and size should be suited to each other, the shape contrasted, and the breed crossed by an opposition of climates; but horses and mares foaled in the same stud should never be joined. These are essential articles, but there are others which should by no means be neglected; as that no short-docked mares be suffered in a stud, because from their being unable to keep off the flies, they are much more tormented by them than others which have a long sweeping tail; and their continual agitation from the sting of these insects occasions a diminution in the quantity of their milk, and has a great influence on the constitution and size of the colt, which will be vigorous in proportion as its dam is a good nurse. Care must also be taken, that the stud mares be such as have been always brought up in pastures, and never over-worked. Mares which have always been brought up in the stable on dry food, and afterwards turned to grass, do not breed at first: some time is required for accustoming them to this new aliment.

Though the usual season for the heat of mares be from the beginning of April to the end of June, yet it is not uncommon to find some among a large number that are in heat before that time: but it is advisable to let this heat pass over without giving them to the stallion, because they would foal in winter; and the colts, besides the inclemency of the season, would have bad milk for their nourishment. Again, if the mares are not in heat till after the end of June, they should not be covered that season; because the colts being foaled in summer, have not time for acquiring strength sufficient to repel the injuries of the following winter.

Many, instead of bringing the stallion to the mare, turn him loose into the close, where all the mares are brought together; and there leave him to choose such as will stand to him. This is a very advantageous method for the mares: they will always take horse more certainly than in the other; but the stallion, in six weeks, will do himself more damage than in several years by moderate exercise, conducted in the manner we have already mentioned.

When the mares are pregnant, and their belly begins to swell, they must be separated from those that are not, lest they hurt them. They usually go 11 months and some days, and foal standing, whereas most other quadrupeds lie down. Those that cannot foal without great difficulty, must be assisted; the foal must be placed in a proper situation; and sometimes, if dead, drawn out with cords. The head of the colt usually

presents itself first, as in all other animals: at its coming out of the matrix, it breaks the secundines or integuments that inclose it, which is accompanied with a great flux of the lymph contained in them; and at the same time one or more solid lumps are discharged, formed by the sediment of the inspissated liquor of the allantoides. This lump, which the ancients called the *hippomanes of the colt*, is so far from being, as they imagined, a mass of flesh adhering to the head of the colt, that it is separated from it by a membrane called *amnios*. As soon as the colt is fallen, the mare licks it, but without touching the hippomanes, which points out another error of the ancients, who affirmed that she instantly devours it.

The general custom is to have a mare covered nine days after her foaling, that no time may be lost; but it is certain, that the mare having, by this means, both her present and future foal to nourish, her ability is divided, and she cannot supply both so largely as she might one only. It would therefore be better, in order to have excellent horses, to let the mares be covered only every other year; they would last the longer, and bring foals more certainly; for, in common studs, it is so far from being true that all mares which have been covered bring colts every year, that it is considered as a fortunate circumstance if half or at most two-thirds of them foal.

Mares, when pregnant, will, admit of copulation; but it is never attended with any superfœtation. They usually breed till they are 14 or 15 years of age; and the most vigorous till they are above 18. Stallions, when well managed, will engender till the age of 20, and even beyond; but it must be observed, that such horses as are soonest made stallions, are also the soonest incapable of generation: thus the large horses, which acquire strength sooner than the slender, and are therefore often used as stallions as soon as they are four years old, are incapable of generation after they are sixteen.

Gelding of Horses. See CASTRATION, FARRIERY Index.

Draught-Horse, in farming, a sort of coarse-made horse destined for the service of the cart or plough. In the choice of these horses for what is called the *slow draught*, they are to be chosen of an ordinary height; for otherwise, when put into the cart, one draws unequally with the other. The draught-horse should be large bodied and strong loined, and of such a disposition, as rather to be too dull than too brisk, and rather to crave the whip than to draw more than is needful. Mares are the fittest for this use for the farmer, as they will be kept cheap, and not only do the work, but be kept breeding, and give a yearly increase of a foal. They should have a good head, neck, breast, and shoulders; for the rest of the shape, it is not of much consequence. Only, for breeding, the mare should have a large belly; for the more room a foal has in the dam, the better proportioned it will be. Draught-horses should be always kept to that employ. Some put them to the saddle on occasion, but it does them great harm, alters their pace, and spoils them for labour. The draught horse ought to have a large broad head, because horses of this shaped head are less subject than others to diseases of the eyes. The ears should be small,

Horse. small, straight and upright; the nostrils large and open, that he may breathe with the more freedom. A horse with a full and bold eye always promises well. On the other hand, a sunk eye and an elevated brow are bad signs. The horse is esteemed fittest for this purpose also, that has a large and round buttock, which neither sinks down nor cuts. He must have a firm and strong tail, and the dock must be thick and well furnished with hair, and placed neither very high nor very low. The legs should be rather flat and broad than round; the roundness of the leg being a fault in a horse destined to labour that will soon ruin him. As to the hinder legs, the thighs should be fleshy and long, and the whole muscle which shows itself on the outside of the thigh should be large and very thick. No country can bring a parallel to the size and strength of our horses destined for the draught. In London there are instances of single horses that are able to draw on a plain, for a small space, the weight of three tons, and which can with ease, and for continuance, draw half that weight. The pack horses of Yorkshire usually carry a burden of 420lb. over the highest hills of the north, as well as the most level roads: but the most remarkable proof of the strength of our British horses is derived from that our mill horses; some of which will at one load carry 13 measures, which at a moderate computation of 70 lb. each, will amount to 910 lb. Nothing is so essential to the health of these servicable creatures as cleanliness; if they are fed ever so well, and not kept clean, they will be subject to numerous diseases.

The servant who has the care of them ought to be up very early, and to clean the racks and mangers from all filth. The currying of them ought to be carefully performed every morning, but not in the stable, for the dust to fall upon the other horses, as it is too often done. After the horses are dusted, they should daily twist a whip of straw hard up, and wetting it in water, rub the legs, shoulders, and body with it. Many of the diseases of draught-horses, which are not owing to nastiness, are owing to bad water; such as is too raw, too muddy, or too cold, being improper. If there be any running stream in the neighbourhood, they should always be led to that to water every day in summer; but in winter, well-water is warmish, and is better for them. If there be a necessity of giving them well-water in summer, it must be drawn up some hours before the time, and exposed to the sunbeams in tubs or troughs; marsh-water or that of lowland ditches is worst of all. When the labouring horse has drunk his water, he should have his oats given him, and these should be carefully sifted, and the manger dusted first. It is a common practice, as soon as a horse is come in from his work, to rub down his legs with a hard whip of hay; but the best judges of horses absolutely condemn this, and observe, that this rubbing of the legs after hard labour brings down humours into them, and makes them stiff.

The rubbing itself is wholesome, but the doing it when the creature is hot is the mischief; while a horse is in a sweat it is a great relief and refreshment to him to have his body rubbed down, but when he is cold is the proper time to rub his legs. The racks are to be well supplied with hay, and the horses should be left

to rest and eat, about two hours, and then led to water; after this their oats should be given them, and they should then go to work again.

In the evening, when the labour of the day is over, the first thing to be done is to examine the feet, and see if any thing is amiss about the shoes; and what earth or gravel is lodged in the foot, between the shoe and the sole, is to be picked out, and some fresh cow-dung put in its place, which will cool and refresh the part.

A very material thing for the preservation of all sorts of cattle, but of none so much as draught-horses, is fresh and clean litter.

Horse-Chestnut. See *ÆSCULUS*, BOTANY *Index*.

Horse-Guards. See *GUARDS*.

Horse-Hunting. See *HUNTER*.

Horse-Measure is a rod of box to slide out of a cane, with a square at the end, being divided into hands and inches to measure the height of horses.

Horse-Muscle. See *MYTILUS*, CONCHOLOGY *Index*.

Race-Horse. See *RACING*.

Horse-Radish. See *COCHLEARIA*, BOTANY *Index*.

Horse-Shoe, a cover or defence for the sole of a horse's foot. See *FARRIERY Index*.

Horse-Shoe-head, a disease in infants, wherein the sutures of the skull are too open, or too great a vacuity is left between them; so that the aperture shall not be totally closed up, or the cranium in that part not be so hard as the rest for some years after. This openness is found to be increased upon the child's catching cold. When the disease continues long, it is reputed a sign of weakness and short life. In this case it is usual to rub the head now and then with warm rum or brandy, mixed with the white of an egg and palm-oil. Sometimes the disorder arises from a collection of waters in the head called a *hydrocephalus*.

Stone-Horse. See *STALLION*.

Horse-Tail. See *EQUISETUM*, BOTANY *Index*.

Horse-Vetch. See *HIPPOCREPIS*, BOTANY *Index*.

War-Horse. The proper rules for choosing a horse for service in war, are these: he should be tall in stature, with a comely head, and out-swelling forehead. His eye should be bright and sparkling, and the white part of it covered by the eye-brow. The ears should be small, thin, short, and pricking; or if long, they should be moveable with ease, and well carried. The neck should be deep, and the breast large and swelling; the ribs bending, the chine broad and straight, and the buttocks round and full. The tail should be high and broad, neither too thick nor too thin; the thigh swelling; the leg broad and flat, and the pastern short. When such a horse is chosen, he must be kept high during the time of his teaching, that he may be full of vigour. His food must be sweet hay, and good clean oats, or two parts of oats and one part of beans or pease, well dried and hardened. The quantity should be half a peck in the morning, and the same quantity at noon and in the evening. Upon his resting days he is to be dressed between five and six in the morning, and watered at seven or eight. In the evening he is to be dressed at four, and watered about five, and he must always have provender given him after watering; he must be littered about eight, and then must have food given him for all night. The night before he is ridden, all

Horse. his hay is to be taken away about nine o'clock, and he must have a handful or two of oats about four in the morning; when he has eaten these, he is to be turned upon the snaffle, and rubbed very well with dry cloths; then saddled, and made fit for his exercise. When he has performed this, he is to be brought sweating into the stable, and rubbed down with dry whisps. When this has been done, the saddle is to be taken off, and he is to be rubbed down with dry cloths; the housing cloth is then to be laid on: and the saddle being again laid on, he is to be walked gently about till thoroughly cool. After this, he must stand without meat two or three hours, then he must be fed; and in the afternoon he is to be rubbed and dressed as before, and watered in the usual manner.

Horse-Worm, in *Natural History*, a species of fly-worm, called also *bott*, produced of eggs deposited by a two-winged fly of the shape and size of the humble bee in the intestines of horses. See *BOTTA*, *FARRIERY Index*.

River-Horse. See *HIPPOTAMUS*, *MAMMALIA Index*.

HORSE is also used in the military language, to express the cavalry; or the body of soldiers who serve on horseback.

The horse includes horse guards, horse grenadiers, and troopers. Dragoons are also frequently comprehended under this name, though they fight on foot: of these there are now 18 regiments; besides three regiments of dragoon-guards raised in 1685. See *GRANADIER*, *DRAGOONS*, and *GUARDS*.

Master of the HORSE. See *MASTER*.

Light-HORSE, are regiments of cavalry, mounted on light swift horses, whose men are small and lightly accoutred. They were first raised in 1757. The denomination arose hence, that anciently they were lightly armed, in comparison of the royal guards, which were armed at all points.

Hungarian HORSE. See *HUSSARS*.

HORSE is also a term used in various arts and manufactures, for something that helps to sustain their work from the ground, for the more commodious working at it.

The horse used by tanners and skinners, also called the *leg*, is a piece of wood cut hollow and roundish, four or five feet long, and placed aslope; upon which they pare their skins to get off the dirt, hair, flesh, &c.

HORSE is also used in carpentry, for a piece of wood jointed across two other perpendicular ones, to sustain the beams, planks, &c. which make bridges over small rivers; and on divers other occasions.

HORSE, in sea-language, is the name of a rope reaching from the middle of a yard to its extremity, or what is called the *yard-arm*, and depending about two or three feet under the yard, for the sailors to tread upon whilst they are loosing, reefing, or furling the sails, rigging out the studding-sail beams, &c. In order, therefore, to keep the horse more parallel to the yard, it is

usually suspended to it at proper distances, by certain ropes called *stirrups*, which hang about two feet under the yard, having an *eye* in their lower ends through which the horse passes.

HORSE is also a thick rope, extended in a perpendicular direction near the fore or after-side of a mast, for the purpose of hoisting or extending some sail upon it. When it is fixed before a mast, it is calculated for the use of a sail called the *square-sail*, whose yard being attached to the horse, by means of a traveller, or bull's eye, which slides up and down occasionally, is retained in a steady position, either when the sail is set, or whilst it is hoisting or lowering. When the horse is placed abaft or behind a mast, it is intended for the try-sail of a snow, and is accordingly very rarely fixed in this position, except in those sloop of war which occasionally assume the form of snows, in order to deceive the enemy.

HORSE is also a cant name introduced into the management of lotteries, for the chance or benefit of a ticket or number for one or more days, upon condition, if it be drawn a prize within the time covenanted for, of returning to the seller an undrawn ticket.—To determine the value of a horse; multiply the amount of the prizes in the lottery by the time the horse is hired for; and from the product subtract the amount of the number of prizes by the value of an undrawn ticket into the time of the horse: the remainder being divided by the number of tickets into the whole time of drawing, the quotient is the value of the horse. See *LOTTERY*.

HORSE-Bread. See *BREAD*.

HORSE-Dung, in *Gardening*, is of great use in making hot beds, for the raising all sorts of early crops as caladig, cucumbers, melons, asparagus, &c. for which purposes no other kind of dung will do so well. Horse-dung ferments the strongest; and if mixed with litter and sea-coal ashes in a due proportion, will continue its heat much longer than any other sort of dung whatsoever; and afterward, when rotted, becomes an excellent manure for most sorts of land: more especially for such as are of a cold nature. For stiff clayey land, horse-dung mixed with sea-coal ashes, and the cleansing of streets, will cause the parts to separate much sooner than any other compost: so that where it can be obtained in plenty, it is always to be recommended for such lands. See *DUNG*.

Annuated HORSE-Hairs, a term used to express a sort of long and slender water-worm, of a blackish colour, and so much resembling a horse-hair, that it is generally by the vulgar supposed to be the hair fallen from a horse's mane into the water as he drinks, and there animated by some strange power. Dr Lister has at large confuted this absurd opinion, in the *Philosophical Transactions*.

HORSE-Hair Worms. See *AMPHIBENA*.

HORSE-Hoeing Husbandry. See *AGRICULTURE*, N° 489.

HORSEMANSHIP;

Or, The Art of Riding, and of Training and Managing, Horses.

SECT. I. *The Method of preparing Horses to be mounted.*Breaking of
Horses.

THOUGH all horses are generally bought at an age when they have already been backed, they should be begun and prepared for the rider with the same care, gentleness, and caution, as if they had never been handled or backed, in order to prevent accidents, which might arise from skittishness or other causes: and as it is proper that they should be taught the figure of the ground they are to go upon when they are at first mounted, they should be previously trotted in a *longe* on circles, without any one upon them.

Earl of
Pembroke's
Directions.

The manner of doing this is as follows: Put an easy *cavesson* upon the horse's nose, and make him go forwards round you, standing quiet, and holding the *longe*; and let another man, if you find it necessary, follow him with a whip. All this must be done very gently, and but a little at a time: for more horses are spoiled by overmuch work, than by any other treatment whatever; and that by very contrary effects: for sometimes it drives them into vice, madness, and despair, and often stupifies and totally dispirits them.

The first obedience required in a horse is going forwards; till he perform this duty freely, never even think of making him rein back, which would inevitably make him restive: as soon as he goes forwards readily, stop and caress him. You must remember in this, and likewise in every other exercise, to use him to go equally well to the right and left; and when he obeys, caress him and dismiss him immediately. If a horse that is very young takes fright and stands still, lead on another horse before him, which probably will induce him instantly to follow. Put a snaffle in his mouth; and when he goes freely, saddle him, girthing him at first very loose. Let the cord, which you hold, be long and loose; but not so much so as to endanger the horse's entangling his legs in it. It must be observed, that small circles, in the beginning, would constrain the horse too much, and put him upon defending himself. No bend must be required at first; never suffer him to gallop false; but whenever he attempts it, stop him without delay, and then set him off afresh. If he gallops of his own accord, and true, permit him to continue it; but if he does it not voluntarily, do not demand it of him at first. Should he fly and jump, shake the cord gently upon his nose without jerking it, and he will fall into his trot again. If he stands still, plunges, or rears, let the man who holds the whip make a noise with it; but never touch him till it be absolutely necessary to make him go on. When you change hands, stop and caress him, and entice him by fair means to come up to you; for by presenting yourself, as some do, on a sudden before horses,

and frightening them to the other side, you run a great risk of giving them a shyness. If he keeps his head too low, shake the *cavesson* to make him raise it; and in whatever the horse does, whether he walks, trots, or gallops, let it be a constant rule that the motion be determined, and really such as is intended, without the least shuffling, pacing, or any other irregular gait.

SECT. II. *The Method of placing the Rider and rendering him firm on Horseback, with some occasional Instructions for Riders and the Horses.*

It is necessary that the greatest attention, and the same gentleness that is used in teaching the horses, be observed likewise in teaching the rider, especially at the beginning. Every method and art must be practised to create and preserve, both in man and horse, all possible feeling and sensibility; contrary to the usage of most riding-masters, who seem industriously to labour at abolishing these principles both in the one and the other. As so many essential points depend upon the manner in which a man is at first placed on horseback, it ought to be considered and attended to with the strictest care and exactness.

The absurdity of putting a man, who perhaps has never before been upon a horse, on a rough trotting horse, on which he is obliged to stick with all the force of his arms and legs, is too obvious to need mentioning. This rough work, all at once, is plainly as detrimental at first, as it is excellent afterwards in proper time. No man can be either well or firmly seated on horseback, unless he be master of the balance of his body, quite unconstrained, with a full possession of himself, and at his ease; none of which requisites can he enjoy, if his attention be otherwise engaged; as it must wholly be in a raw, unsupplied, and unprepared lad, who is put at once upon a rough horse; in such a distressful state, he is forced to keep himself on at any rate, by holding to the bridle (at the expense of the sensibility both of his own hand and the horse's mouth), and by clinging with his legs, in danger of his life, and to the certain deprivation of a right feeling in the horse.

The first time a man is put on horseback, it ought to be upon a very gentle one. He never should be made to trot, till he is quite easy in the walk; nor gallop, till he is able to trot properly. The same must be observed in regard to horses; they should never be made to trot till they are obedient, and their mouths are well formed on a walk, nor be made to gallop, till the same be effected on a trot. When he is arrived at such a degree of firmness in his seat, the more he trots, and the more he rides rough horses, the better. This is not only the best method, but also the easiest and the shortest: by it a man is soon made sufficiently.

Instructions concerning both Riders and Horses.

ciently a horseman for a soldier: but by the other detestable methods that are commonly used, a man, instead of improving, contracts all sorts of bad habits, and rides worse and worse every day; the horse too becomes daily more and more unfit for use. In proceeding according to the manner proposed, a man is rendered firm and easy upon the horse, both his own and the horse's sensibility is preserved, and each in a situation fit to receive and practise all lessons effectually.

Among the various methods that are used of placing people on horseback, few are directed by reason. Before you let the man mount, teach him to know, and always to examine, if the curb be well placed, (that is, when the horse has a bit in his mouth, which at first he should not, but only a snaffle, till the rider is firm in his seat, and the horse also somewhat taught); likewise to know if the nose-band be properly tight; and the throat-band loosish; and the mouth-piece neither too high nor too low in the horse's mouth, but rightly put, so as not to wrinkle the skin nor to hang lax; the girths drawn moderately, but not too tight; and the crupper and the breast-plate properly adjusted. A very good and careful hand may venture on a bit at first, and succeed with it full as well as by beginning with a snaffle alone: on colts, indeed, it is better, in all schools whatsoever, to avoid any pressure of the bars just at first, which a curb, though ever so delicately used, must in some degree occasion. When the bridle, &c. have been well looked to, let the man approach the horse gently near the shoulder; then taking the reins and a handful of the mane in his left hand, let him put his foot softly in the left stirrup, by pulling it towards him, till he touch the horse with his toe; then raising himself up, let him rest a moment on it with his body upright, but not stiff; and after that, passing his right leg clear over the saddle without rubbing against any thing, let him seat himself gently down. He must be cautious not to take the reins too short, for fear of making the horse rear, run, or fall back, or throw up his head; but let him hold them of an equal length, neither tight nor slack, and with the little finger betwixt them. It is fit that horses should be accustomed to stand still to be mounted, and not to stir till the rider pleases. All soldiers should be instructed to mount and dismount equally well on both sides, which may be of great use in times of hurry and confusion. Then place the man in his saddle, with his body rather back, and his head held up with ease, without stiffness; seated neither forwards, nor very far backwards; with the breast pushed out a little, and the lower part of the body likewise a little forwards; the thighs and legs turned in without constraint, and the feet in a straight line, neither turned in nor out. By this position, the natural weight of the thighs has a proper and sufficient pressure of itself, and the legs are in readiness to act when called upon; they must hang down easy and naturally; and be so placed, as not to be wriggling about, touching and tickling the horse's sides, but always near them in case they should be wanted, as well as the heels.

The body must be carefully kept easy and firm, and without any rocking when in motion; which is a bad habit very easily contracted, especially in galloping. The left elbow must be gently leant against the body,

a little forwards; unless it be so rested, the hand cannot be steady, but will always be checking, and consequently have pernicious effects on the horse's mouth. And the hand ought to be of equal height with the elbow; if it were lower, it would constrain and confine the motion of the horse's shoulders; but, as the mouths of horses are different, the place of the hand also must occasionally differ: a leaning, low, heavy, fore-hand, requires a high hand; and a horse that pokes out his nose, a low one. The right-hand arm must be placed in symmetry with the left; only let the right hand be a little more forward or backward, higher or lower, as occasion may require, in order that both hands may be free; both arms must be a little bent at the elbow, to prevent stiffness.

A soldier's right hand should be kept unemployed in riding; it carries the sword, which is sufficient business for it.

There remains one farther observation, that ought not to be omitted, about the hand, that it must be kept clear of the body; i. e. about two inches and a half forwards from it, with the nails turned opposite to the belly, and the wrist a little rounded with ease; a position not less graceful than ready for slackening, tightening, and moving the reins from one side to the other, as may be found necessary.

When the men are well placed, the more rough trotting they have without stirrups the better; but with a strict care always, that their position be preserved very exactly. In all cases, great care must be taken to hinder their clinging with their legs; in short, no sticking by hands or legs is ever to be allowed of at any time. If the motion of the horse be too rough, slacken it, till the rider grows by degrees more firm; and when he is quite firm and easy on his horse in every kind of motion, stirrups may be given him; but he must never leave off trotting often without any.

The stirrups must be neither short nor long; but of such a length, that when the rider, being well placed, puts his feet into them (about one-third of the length of each foot from the point of it), the points may be between two and three inches higher than the heels. The rider must not bear upon his stirrups, but only let the natural weight of his legs rest on them: For if he bears upon them he would be raised above and out of his saddle; which he should never be, except in charging sword in hand, with the body inclined forwards at the very instant of attacking. Spurs may be given as soon as the rider is grown familiar with stirrups; or even long before, if his legs are well placed.

A hand should always be firm, but delicate: a horse's mouth should never be surprised by any sudden transition of it, either from slack to tight, or from tight to slack. Every thing in horsemanship must be effected by degrees, but at the same time with spirit and resolution. The hand which by giving and taking properly, gains its point with the least force, is the best; and the horse's mouth, under this same hand's directions, will also consequently be the best, supposing equal advantages in both from nature. This principle of gentleness should be observed upon all occasions in every branch of horsemanship. Sometimes the right hand may be necessary, upon some trouble-

Instructions concerning both Riders and Horses.

Instruc-
tions con-
cerning
both Riders
and Horses.

Instruc-
tions con-
cerning
both Riders
and Horses.

some horses, to assist the left; but the seldomer this is done, the better; and especially in a soldier, who has a sword to carry, and to make use of.

The snaffle must on all occasions be uppermost; that is to say, the reins of it must be above those of the bridle, whether the snaffle or the bit be used separately, or whether they be both used together. When the rider knows enough, and the horse is sufficiently prepared and settled to begin any work towards suppling, one rein must be shortened according to the side worked to; but it must never be so much shortened, as to make the whole strength rest on that rein alone: for, not to mention that the work would be false and bad, one side of the horse's mouth would by that means be always deadened; whereas, on the contrary, it should always be kept fresh by its own play, and by the help of the opposite rein's acting delicately in a somewhat smaller degree of tension; the joint effect of which produces in a horse's mouth the proper, gentle, and easy, degree of *appui* or bearing.

A coward and a madman make alike bad riders, and are both alike discovered and confounded by the superior sense of the creature they are mounted upon, who is equally spoilt by both, though in very different ways. The coward, by suffering the animal to have his own way, not only confirms him in his bad habits, but creates new ones in him: and the madman, by false and violent motions and corrections, drives the horse, through despair, into every bad and vicious trick that rage can suggest.

It is very requisite in horsemanship, that the hand and legs should act in correspondence with each other in every thing; the latter always subservient and assistant to the former. Upon circles, in walking, trotting, or galloping, the outward leg is the only one to be used, and that only for a moment at a time, in order to set off the horse true, or put him right if he be false; and as soon as that is done, it must be taken away again immediately: but if the horse be lazy, or otherwise retains himself, both legs must be used and pressed to his sides at the same time together. The less the legs are used in general, the better. Very delicate good riders, with horses they have dressed themselves, will scarcely ever want their help. By the term *outward* is understood the side which is more remote from the centre; and by *inward* is meant the side next to the centre. In reining back, the rider should be careful not to use his legs, unless the horse backeth on his shoulders; in which case they must be both applied gently at the same time, and correspond with the hand. If the horse refuse to back at all, the rider's legs must be gently approached, till the horse lifts up a leg, as if to go forwards; at which time, when that leg is in the air, the rein of the same side with that leg which is lifted up will easily bring that same leg backwards, and accordingly oblige the horse to back; but if the horse offers to rear, the legs must be instantly removed away. The inward rein must be tighter on circles, so that the horse may bend and look inwards; and the outward one crossed over a little towards it; and both held in the left hand.

Let the man and horse begin on very slow motions, that they may have time to understand and reflect on

what is taught them; and in proportion as the effects of the reins are better comprehended, and the manner of working becomes more familiar, the quickness of motion must be increased. Every rider must learn to feel, without the help of the eye, when a horse goes false, and remedy the fault accordingly: this is an intelligence, which nothing but practice, application, and attention, can give, in the beginning on slow motions. A horse may not only gallop false, but also trot and walk false. If a horse gallops false, that is to say, if going to the right he leads with the left leg, or if going to the left he leads with the right; or in case he is disunited, *i. e.* if he leads with the opposite leg behind to that which he leads with before; stop him immediately, and put him off again properly. The method of effecting this, is by approaching your outward leg, and putting your hand outwards; still keeping the inward rein the shorter, and the horse's head inwards, if possible; and if he should still resist, then bend and pull his head outwards also; but replace it again, bent properly inwards, the moment he goes off true. A horse is said to be disunited to the right, when going to the right, and consequently leading with the right leg before, he leads with the left behind; and is said to be disunited to the left, when going to the left, and consequently leading with the left leg before, he leads with the right behind. A horse may at the same time be both false and disunited; in correcting both which faults, the same method must be used. He is both false and disunited to the right, when in going to the right he leads with the left leg before, and the right behind; notwithstanding that hinder leg be with propriety more forward under his belly than the left, because the horse is working to the right: And he is false and disunited to the left, when in going to the left he leads with the right leg before and the left behind; notwithstanding, as above, that hinder leg be with propriety more forward under his belly than the right, because the horse is working to the left.

In teaching men a right seat on horseback, the greatest attention must be given to prevent stiffness, and sticking by force in any manner upon any occasion: stiffness disgraces every right work; and sticking serves only to throw a man (when displaced) a great distance from his horse by the spring he must go off with: whereas by a proper equilibrating position of the body, and by the natural weight only of the thighs, he cannot but be firm and secure in his seat.

As the men become more firm, and the horses more supple, it is proper to make the circles less, but not too much so, for fear of throwing the horses forwards upon their shoulders.

Some horses, when first the bit is put into their mouths, if great care be not taken, will put their heads very low. With such horses, raise your right hand with the *bridoon* in it, and play at the same time with the bit in the left hand, giving and taking.

On circles, the rider must lean his body inwards; unless great attention be given to make him do it, he will be perpetually losing his seat outwards. It is scarce possible for him to be displaced, if he leans his body properly inwards.

Of Suppling
Horses.

SECT. III. *The Method of suppling Horses with Men upon them, by the ÉPAULE en dedans, &c. with and without a Longe, on Circles and on straight Lines.*

WHEN a horse is well prepared and settled in all his motions, and the rider firm, it will be proper then to proceed on towards a farther suppling and teaching of both.

In setting out upon this new work, begin by bringing the horse's head a little more inwards than before, pulling the inward rein gently to you by degrees. When this is done, try to gain a little on the shoulders, by keeping the inward rein the shorter, as before, and the outward one crossed over towards the inward one. The intention of these operations is this: The inward rein serves to bring in the head, and procure the bend; whilst the outward one, that is a little crossed, tends to make that bend perpendicular and so it should be, that is to say, to reduce the nose and the forehead to be in a perpendicular line with each other; it also serves, if put forwards, as well as also crossed, to put the horse forwards, if found necessary; which is often requisite, many horses being apt in this and other works rather to lose their ground backwards than otherwise, when they should rather advance; if the nose were drawn in towards the breast beyond the perpendicular, it would confine the motion of the shoulders, and have other bad effects. All other bends, besides what are above specified, are false. The outward rein, being crossed, not in a forward sense, but rather a little backwards, serves also to prevent the outward shoulder from getting too forwards, and makes it approach the inward one; which facilitates the inward leg's crossing over the outward one, which is the motion that so admirably supple the shoulders. Care must be taken, that the inward leg pass over the outward one, without touching it: this inward leg's crossing over must be helped also by the inward rein, which you must cross towards and over the outward rein every time the outward leg comes to the ground, in order to lift and help the inward leg over it: at any other time, but just when the outward leg comes to the ground, it would be wrong to cross the inward rein, or to attempt to lift up the inward leg by it; nay, it would be demanding an absolute impossibility, and lugging about the reins and horse to no purpose: because in this case, a very great part of the horse's weight resting then upon that leg, would render such an attempt not only fruitless, but also prejudicial to the sensibility of the mouth, and probably oblige him to defend himself; and, moreover, it would put the horse under a necessity of straddling before, and also of leading with the wrong leg, without being productive of any suppling motion whatsoever.

When the horse is thus far familiarly accustomed to what you have required of him, then proceed to effect by degrees the same crossing in his hinder legs. By bringing in the fore legs more, you will of course engage the hinder ones in the same work; if they resist, the rider must bring both reins more inward: and, if necessary, put back also, and approach his inward leg to the horse; and if the horse throws out his croup too far, the rider must bring both reins outwards, and, if

absolutely necessary, he must also make use of his outward leg, in order to replace the horse properly: observing that the croup should always be considerably behind the shoulders, which in all actions must go first; and the moment that the horse obeys, the rider must put his hand and leg again in their usual position.

Nothing is more ungraceful in itself, more detrimental to a man's seat, or more destructive of the sensibility of a horse's sides, than a continual wriggling unsettledness in a horseman's legs, which prevents the horse from ever going a moment together true, steady, or determined.

A horse should never be turned, without first moving a step forwards: and when it is doing, the rider must not lift his elbow, and displace himself; a motion only of the hand from the one side to the other being sufficient for that purpose. It must also be a constant rule, never to suffer a horse to be stopped, mounted, or dismounted, but when he is well placed. The slower the motions are when a man or horse is taught any thing, the better.

At first, the figures worked upon must be great, and afterwards made less by degrees, according to the improvement which the man and horse make; and the cadenced pace also, which they work in, must be accordingly augmented. The changes from one side to the other must be in a bold determined trot, and at first quite straight forwards, without demanding any side-motion on two *pistes*, which is very necessary to require afterwards when the horse is sufficiently suppled. By two *pistes* is meant, when the fore parts and hinder parts do not follow, but describe two different lines.

In the beginning, a *longe* is used on circles, and also on straight lines, to help both the rider and the horse; but afterwards, when they are grown more intelligent, they should go alone. At the end of the lesson, rein back; then put the horse, by a little at a time, forwards, by approaching both legs gently to his sides, and playing with the bridle: if he rears, push him out immediately into a full trot. Shaking the cavesson on the horse's nose, and also putting one's self before him and rather near to him, will generally make him back, though he otherwise refuse to do it: and moreover a slight use and approaching of the rider's legs, will sometimes be necessary in backing, in order to prevent the horse from doing it too much upon his shoulders; but the pressure of the legs ought to be very small, and taken quite away the moment that he puts himself enough upon his haunches. If the horse does not back upon a straight line properly, the rider must not be permitted to have recourse immediately to his leg, and so distort himself by it; but first try, if crossing over his hand and reins to which ever side may be necessary, it will not alone sufficient: which most frequently it will; if not, then employ the leg.

After a horse is well prepared and settled, and goes freely on in all his several paces, he ought to be in all his works kept, to a proper degree, upon his haunches, with his hinder legs well placed under him; whereby he will be always pleasant to himself and his rider, will be light in hand, and ready to execute whatever may be demanded of him, with facility, vigour, and quickness.

The common method that is used of forcing a horse

Of the Head to the Wall, &c. side-wise, is a most glaring absurdity, and very hurtful to the animal in its consequences; for, instead of suppling him, it obliges him to stiffen and defend himself, and often makes a creature that is naturally benevolent, restive, frightened, and vicious.

For horses who have very high and long fore-hands, and who poke out their noses, a running snaffle is of excellent use; but for such as bore and keep their heads low, a common one is preferable; though any horse's head indeed may be kept up also with a running one, by the rider's keeping his hands very high and forwards: but whenever either is used alone without a bridle upon horses that carry their heads low and that bore, it must be sawed about from one side to the other.

This lesson of the *epaule en dedans* should be taught to such people as are likely to become useful in helping to teach men and to break horses; and the more of such that can be found the better; none others should ever be suffered upon any occasion to let their horses look any way besides the way they are going. But all horses whatever, as likewise all men who are designed for the teaching others, must go thoroughly and perfectly through this excellent lesson, under the directions of intelligent instructors, and often practise it too afterwards; and when that is done, proceed to and be finished by the lessons of head and tail to the wall.

SECT. IV. *Of the Head to the Wall, and of the Croup to the Wall.*

THIS lesson should be practised immediately after that of the *epaule en dedans*, in order to place the horse properly the way he goes, &c. The difference between the head to the wall, and the croup to the wall, consists in this: in the former, the fore-parts are more remote from the centre, and go over more ground; in the latter, the hinder parts are more remote from the centre, and consequently go over more ground: in both, as likewise in all other lessons, the shoulders must go first. In riding-horses, the head to the wall is the easier lesson of the two at first, the line to be worked upon being marked by the wall, not far from his head.

The motion of the legs to the right is the same as that of the *epaule en dedans* to the left, and so *vice versa*; but the head is always bent and turned differently: in the *epaule en dedans*, the horse looks the contrary way to that which he goes; in this, he looks the way he is going.

In the beginning, very little bend must be required: too much at once would astonish the horse, and make him defend himself: it is to be augmented by degrees. If the horse absolutely refuses to obey, it is a sign that either he or his rider has not been sufficiently prepared by previous lessons. It may happen that weakness or a hurt in some part of the body, or sometimes temper, though seldom, may be the cause of the horse's defending himself: it is the rider's business to find out from whence the obstacle arises; and if he finds it to be from the first-mentioned cause, the previous lessons must be resumed again for some time; if from the second, proper remedies must be applied; and if from

VOL. X. Part II.

†

the last cause, when all fair means that can be tried have failed, proper corrections with coolness and judgment must be used.

Of the Head to the Wall, &c.

In practising this lesson to the right, bend the horse to the right with the right rein; helping the left leg over the right (at the time when the right leg is just come to the ground), with the left rein crossed towards the right, and keeping the right shoulder back with the right rein towards your body, in order to facilitate the left leg's crossing over the right; and so likewise *vice versa* to the left, each rein helping the other by their properly mixed effects. In working to the right, the rider's left leg helps the hinder parts on to the right, and his right leg stops them if they get too forwards; and so *vice versa* to the left: but neither ought to be used, till the hand being employed in a proper manner has failed, or finds that a greater force is necessary to bring about what is required than it can effect alone: for the legs should not only be corresponding with, but also subservient to, the hand; and all unnecessary aids, as well as all force, ought always to be avoided as much as possible.

In the execution of all lessons, the equilibrium of the rider's body is of great use to the horse; it ought always to go with and accompany every motion of the animal; when to the right, to the right; and when to the left, to the left.

Upon all horses, in every lesson and action, it must be observed, that there is no horse but has his own peculiar appui or degree of bearing, and also a sensibility of mouth, as likewise a bearing of his own, which it is absolutely necessary for the rider to discover and make himself acquainted with. A bad rider always takes off at least the delicacy of both, if not absolutely destroys it. The horse will inform his rider when he has got his proper bearing in the mouth, by playing pleasantly and steadily with his bit, and by the spray about his chaps. A delicate and good hand will not only always preserve a light appui, or bearing, in its sensibility; but also of a heavy one, whether naturally so or acquired, make a light one. The lighter this appui can be made, the better; provided that the rider's hand corresponds with it; if it does not, the more the horse is properly prepared, so much the worse. Instances of this inconvenience of the best of appuis, when the rider is not equally taught with the horse, may be seen every day in some gentlemen, who try to get their horses *bitted* as they call it, without being suitably prepared themselves for riding them: the consequence of which is, that they ride in danger of breaking their necks; till at length, after much hauling about, and by the joint insensibility and ignorance of themselves and their grooms, the poor animals gradually become mere senseless unfeeling posts; and thereby grow, what they call, *settled*. When the proper appui is found, and made of course as light as possible, it must not be kept duly fixed without variation, but be played with; otherwise one equally continued tension of reins would render both the rider's hand and the horse's mouth very dull. The slightest and frequent giving and taking is therefore necessary to keep both perfect.

Whatever pace or degree of quickness you work in,

4 I

(be

To make (be it ever so fast, or ever so slow), it must be cadenced; time is as necessary for a horseman as for a musician.

This lesson of the head and of the tail to the wall, must be taught every soldier: scarce any manœuvre can be well performed without it. In closing and opening of files, it is almost every moment wanted.

SECT. V. *The Method of making Horses stand Fire, Noises, Alarms, Sights, &c.*

IN order to make horses stand fire, the sound of drums, and all sorts of different noises, you must use them to it by degrees in the stable at feeding time; and instead of being frightened at it, they will soon come to like it as a signal for eating.

With regard to such horses as are afraid of burning objects, begin by keeping them still at a certain distance from some lighted straw; caress the horse; and in proportion as his fright diminishes, approach gradually the burning straw very gently, and increase the size of it. By this means he will very quickly be brought to be so familiar with it, as to walk undaunted even through it.

As to horses that are apt to lie down in the water, if animating them, and attacking them vigorously, should fail of the desired effect, then break a straw-bottle full of water upon their heads, and let the water run into their ears, which is a thing they apprehend very much.

All troop-horses must be taught to stand quiet and still when they are shot off from, to stop the moment you present, and not to move after firing till they are required to do it; this lesson ought especially to be observed in light troops: in short, the horses must be taught to be so cool and undisturbed, as to suffer the rider to act upon him with the same freedom as if he was on foot. Patience, coolness, and temper, are the only means requisite for accomplishing this end. Begin by walking the horse gently, then stop and keep him from stirring for some time, so as to accustom him by degrees not to have the least idea of moving without orders: if he does, then back him; and when you stop him, and he is quite still, leave the reins quite loose.

To use a horse to fire-arms, first put a pistol or a carbine in the manger with his feed: then use him to the sound of the lock and the pan; after which, when you are upon him, show the piece to him, presenting it forwards, sometimes on one side, sometimes on the other: when he is thus far reconciled, proceed to flash in the pan; after which, put a small charge into the piece, and so continue augmenting it by degrees to the quantity which is commonly used: if he seems uneasy, walk him forward a few steps slowly; and then stop, back, and caress him. Horses are often also disquieted and unsteady at the clash, and drawing, and returning of swords; all which they must be familiarized to by little and little, by frequency and gentleness.

It is very expedient for all cavalry in general, but particularly for light cavalry, that their horses should be very ready and expert in leaping over ditches, hedges, gates, &c. The leaps, of whatever sort they are, which the horses are brought to in the beginning, ought to

be very small ones; the riders must keep their bodies back, raise their hands a little in order to help the fore-parts of the horse up, and be very attentive to their equilibrium. It is best to begin at a low bar covered with furze, which pricking the horse's legs, if he does not raise himself sufficiently, prevents his contracting a sluggish and dangerous habit of touching, as he goes over, which any thing yielding and not pricking would give him a custom of doing. Let the ditches you first bring horses to be narrow; and in this, as in every thing else, let the increase be made by degrees. Accustom them to come up to every thing which they are to leap over, and to stand coolly at it for some time; and then to raise themselves gently up in order to form to themselves an idea of the distance. When they leap well standing, then use them to walk gently up to the leap, and to go over it without first halting at it; and after that practice is familiar to them, repeat the like in a gentle trot, and so by degrees faster and faster, till at length it is as familiar to them to leap flying on a full gallop as any other way: all which is to be acquired with great facility by calm and soft means, without any hurry.

As horses are naturally apt to be frightened at the sight and smell of dead horses, it is advisable to habituate them to walk over and leap over carcases of dead horses: and as they are particularly terrified at this sight, the greater gentleness ought consequently to be used.

Horses should also be accustomed to swim, which often may be necessary upon service; and if the men and horses both are not used to it, both may be frequently liable to perish in the water. A very small portion of strength is sufficient to guide a horse, anywhere indeed, but particularly in the water, where they must be permitted to have their heads, and be no ways constrained in any shape.

The unreasonable rage in Britain of cutting off all extremities from horses, is in all cases a very pernicious custom. It is particularly so in regard to a troop-horse's tail. It is almost incredible, how much they suffer at the picket for want of it: constantly fretting, and sweating, kicking about and laming one another, tormented, and stung off their meat, miserable, and helpless; while other horses, with their tails on, brush off all flies, are cool and at their ease, and mend daily; whilst the docked ones grow every hour more and more out of condition.

SECT. VI. *The Method of reining back,—and of moving forwards immediately after;—of Picking,—of Pickets, &c.*

NEVER finish your work by reining back with horses that have any disposition towards retaining themselves; but always move them forwards, and a little upon the haunches also, after it, before you dismount, (unless they retain themselves very much indeed, in which case nothing at all must be demanded from the haunches). This lesson of reining back, and picking, is excellent to conclude with, and puts a horse well and properly upon the haunches: It may be done, according as horses are more or less suppled, either going forwards, backing, or in the same place: if it is done well advancing, or at most on the same spot, it is fully sufficient for a soldier's

Of Curing
Restiveness,
&c.

dier's horse: For to piase in backing, is rather too much to be expected in the hurry which cannot but attend such numbers both of men and horses as must be taught together in regiments. This lesson must never be attempted at all, till horses are very well supplied, and somewhat accustomed to be put together; otherwise it will have very bad consequences, and create restiveness. If they refuse to back, and stand motionless, the rider's legs must approach with the greatest gentleness to the horse's sides; at the same time that the hand is acting on the reins to solicit the horse's backing. This seldom fails of procuring the desired effect, by raising one of the horse's fore-legs, which being in the air, has no weight upon it, and is consequently very easily brought backwards by a small degree of tension in the reins. When this lesson is well performed, it is very noble and useful, and has a pleasing air; it is an excellent one to begin teaching scholars with.

The lesson is particularly serviceable in the pillars, for placing scholars well at first. Very few regimental riding-houses have pillars, and it is fortunate they have not; for though, when properly made use of with skill, they are one of the greatest and best discoveries in horsemanship; they must be allowed to be very dangerous and pernicious, when they are not under the direction of a very knowing person.

SECT. VII. *The Method of curing Restiveness, Vices, Defences, Starting, &c.*

WHENEVER a horse makes resistance, one ought, before remedy or correction is thought of, to examine very minutely all the tackle about him, if any thing hurts or tickles him, whether he has any natural or accidental weakness, or in short any the least impediment in any part. For want of this precaution, many fatal disasters happen: the poor dumb animal is frequently accused falsely of being restive and vicious; is used ill without reason; and, being forced into despair, is in a manner obliged to act accordingly, be his temper and inclination ever so well disposed. It is very seldom the case, that a horse is really and by nature vicious; but if such be found, he will despise all carresses, and then chastisements become necessary.

Correction, according as you use it, throws a horse into more or less violent action, which, if he be weak, he cannot support: but a vicious strong horse is to be considered in a very different light, being able both to undergo and consequently to profit by all lessons; and is far preferable to the best natured weak one upon earth. Patience and attention are never failing means to reclaim such a horse: in whatsoever manner he defends himself, bring him back frequently with gentleness (not however without having given him proper chastisement if necessary) to the lesson which he seems most averse to. Horses are by degrees made obedient, through the hope of recompense and the fear of punishment: how to mix these two motives judiciously together, is a very difficult matter; it requires much thought and practice; and not only a good head, but a good heart likewise. The coolest and best natured rider will always succeed best. By a dexterous use of the incitements above mentioned, you will gradually bring the horse to temper and obedience; more

Of Curing
Restiveness,
&c.

force, and want of skill and coolness, would only tend to confirm him in bad tricks. If he be impatient or choleric, never strike him, unless he absolutely refuse to go forward; which you must resolutely oblige him to do, and which will be of itself a correction, by preventing his having time to meditate and put in execution any defence by retaining himself. Resistance in horses, you must consider, is sometimes a mark of strength and vigour, and proceeds from spirit, as well as sometimes from vice and weakness. Weakness frequently drives horses into viciousness, when any thing wherein strength is necessary is demanded from them; nay, it inevitably must: great care therefore should always be taken to distinguish from which of these two causes any remedy or punishment is thought of. It may sometimes be a bad sign when horses do not at all defend themselves, and proceed from a sluggish disposition, a want of spirit, and of a proper sensibility. Whenever one is so fortunate as to meet with a horse of just the right spirit, activity, delicacy of feeling, with strength and good nature, he cannot be cherished too much; for such a one is a rare and inestimable jewel, and, if properly treated, will in a manner do every thing of himself. Horses are oftener spoilt by having too much done to them, and by attempts to dress them in too great an hurry, than by any other treatment.

If after a horse has been well supplied, and there are no impediments, either natural or accidental, if he still persist to defend himself, chastisements then become necessary: but whenever this is the case, they must not be frequent but always firm, though always as little violent as possible; for they are both dangerous and very prejudicial when frequently or slightly played with, and still more so when used too violently.

It is impossible, in general, to be too circumspect in lessons of all kinds, in aids, chastisements, or carresses. Soon have quicker parts, and more cunning, than others. Many will imperceptibly gain a little every day on the rider. Various, in short, are their dispositions and capacities. It is the rider's business to find out their different qualities, and to make them sensible how much he loves them, and desires to be loved by them; but at the same time that he does not fear them, and will be master.

Plunging is a very common defence among restive and vicious horses: if they do it in the same place, or backing, they must, by the rider's legs and spurs firmly applied, be obliged to go forwards, and their heads kept up high. But if they do it flying forwards, keep them back, and ride them gently and very slow for a good while together. Of all bad tempers and qualities in horses, those which are occasioned by harsh treatment and ignorant riders are the worst.

Rearing is a bad vice, and, in weak horses especially, a very dangerous one. Whilst the horse is up, the rider must yield his hand; and when the horse is descending, he must vigorously determine him forwards: if this be done at any other time but whilst the horse is coming down, it may add a spring to his rearing, and make him fall backwards. With a good hand on them, horses seldom persist in this vice; for they are themselves naturally much afraid of falling backwards. If

Rules for
Bad
Horsemen.

this method fails, you must make the horse kick up behind, by getting somebody on foot to strike him behind with a whip; or, if that will not effect it, by pricking him with a goad.

Starting often proceeds from a defect in the sight; which therefore must be carefully looked into. Whatever the horse is afraid of, bring him up to it gently; if you caress him every step he advances, he will go quite up to it by degrees, and soon grow familiar with all sorts of objects. Nothing but great gentleness can correct this fault; for if you inflict punishment, the apprehension of chastisement becomes prevalent, and causes more starting than the fear of the object. If you let him go by the object, without bringing him up to it, you increase the fault, and confirm him in his fear: the consequence of which is, he takes his rider perhaps a quite contrary way from what he was going, becomes his master, and puts himself and the person upon him every moment in great danger.

With such horses as are to a very great degree fearful of any objects, make a quiet horse, by going before them, gradually entice them to approach nearer and nearer to the thing they are afraid of. If the horse, thus alarmed, be undisciplined and headstrong, he will probably run away with his rider; and if so, his head must be kept up high, and the snaffle sawed backwards and forwards from right to left, taking up and yielding the reins of it, as also the reins of the bit: but this latter must not be sawed backwards and forwards like the snaffle, but only taken up and yielded properly. No man ever yet did, or ever will stop a horse, or gain any one point over him, by main force, or by pulling a dead weight against him.

SECT. VIII. Rules for bad Horsemen.

Thomson's
Rules.

IN the first place, every horse should be accustomed to stand still when he is mounted. One would imagine this might be readily granted; yet we see how much the contrary is practised. When a gentleman mounts at a livery-stable, the groom takes the horse by the bit, which he bends tight round his under jaw: the horse striving to go on, is forced back; advancing again, he frets, as he is again stopped short, and hurt by the manner of holding him. The rider, in the mean time, mounting without the bridle, or at least holding it but slightly, is helped to it by the groom, who being thoroughly employed by the horse's fluttering, has at the same time both bridle and stirrup to give. This confusion would be prevented, if every horse was taught to stand still when he is mounted. Forbid your groom, therefore, when he rides your horse to water, to throw himself over him from a horse-block, and kick him with his leg, even before he is fairly upon him. This wrong manner of mounting is what chiefly teaches your horse the vicious habit against which we are here warning. On the other hand, a constant practice of mounting in the proper manner, is all that is necessary to prevent a horse's going on till the rider is quite adjusted in the saddle.

The next thing necessary therefore is, that the rider should mount properly. The common method is to stand near the croup or hinder part of the horse, with the bridle held very long in the right hand. By this

Rules for
Bad
Horsemen.

manner of holding the bridle before you mount, you are liable to be kicked; and when you are mounted, your horse may go on some time, or play what gambols he pleases, before the rein is short enough in your hand to prevent him. It is common likewise for an awkward rider, as soon as his foot is in the stirrup, to throw himself with all his force to gain his seat; which he cannot do, till he hath first overbalanced himself on one side or the other: he will then wriggle into it by degrees. The way to mount with ease and safety is, to stand rather before than behind the stirrup. In this posture take the bridle short, and the mane together in your left hand, helping yourself to the stirrup with your right, so that your toe may not touch the horse in mounting. While your left foot is in the stirrup, move on your right, till you face the side of the horse, looking across over the saddle. Then with your right hand grasp the hinder part of the saddle; and with that and your left, which holds the mane and bridle, lift yourself upright on your left foot. Remain thus a mere instant on your stirrup, only so as to divide the action into two motions. While you are in this posture, you have a sure hold with both hands, and are at liberty, either to get safely down, or to throw your leg over and gain your seat. By this deliberate motion, likewise, you avoid, what every good horseman would endeavour to avoid, putting your horse into a flutter.

When you dismount, hold the bridle and mane together in your left hand, as when you mounted; put your right hand on the pommel of the saddle, to raise yourself; throw your leg back over the horse, grasp the hinder part of the saddle with your right hand, remain a moment on your stirrup, and in every respect dismount as you mounted; only what was your first motion when you mounted, becomes the last in dismounting. Remember not to bend your right knee in dismounting, lest your spur should rub against the horse.

It may be next recommended to hold your bridle at a convenient length. Sit square, and let not the purchase of the bridle pull forward your shoulder; but keep your body even, as it would be if each hand held a rein. Hold your reins with the whole grasp of your hand, dividing them with your little finger. Let your hand be perpendicular; your thumb will then be uppermost, and placed on the bridle. Bend your wrist a little outward: and when you pull the bridle, raise your hand toward your breast, and the lower part of the palm rather more than the upper. Let the bridle be at such a length in your hand, as, if the horse should stumble, you may be able to raise his head, and support it by the strength of your arms, and the weight of your body thrown backward. If you hold the rein too long, you are subject to fall backward as your horse rises.

If, knowing your horse perfectly well, you think a tight rein unnecessary, advance your arm a little (but not your shoulder) towards the horse's head, and keep your usual length of rein. By this means, you have a check upon your horse, while you indulge him.

If you ride with a curb, make it a rule to hook on the chain yourself; the most quiet horse may bring his rider into danger, should the curb hurt him. If, in fixing the curb, you turn the chain to the right,

the

Rules for
Bad
Horsemen.

the links will unfold themselves, and then oppose a farther turning. Put on the chain loose enough to hang down on the horse's under lip, so that it may not rise and press his jaw, till the reins of the bridle are moderately pulled.

If your horse has been used to stand still when he is mounted, there will be no occasion for a groom to hold him: but if he does, suffer him not to touch the reins, but that part of the bridle which comes down the cheek of the horse. He cannot then interfere with the management of the reins, which belongs to the rider only; and holding a horse by the curb (which is ever painful to him) is evidently improper when he is to stand still.

Another thing to be remembered is, not to ride with your arms and elbows as high as your shoulders; not let them shake up and down with the motion of the horse. The posture is unbecoming, and the weight of the arms and of the body too if the rider does not sit still) acts in continual jerks on the jaw of the horse, which must give him pain, and make him unquiet, if he has a tender mouth or any spirit.

Bad riders wonder why horses are gentle as soon as they are mounted by skilful ones, though their skill seems unemployed: the reason is, the horse goes at his ease, yet finds all his motions watched; which he has sagacity enough to discover. Such a rider hides his whip, if he finds his horse is afraid of it; and keeps his legs from his sides, if he finds he dreads the spur.

Avoid the ungraceful custom of letting your legs shake against the sides of the horse: and as you are not to keep your arms and elbows high, and in motion; so you are not to rivet them to your sides, but let them fall easy. One may, at a distance, distinguish a genteel horseman from an awkward one: the first sits still, and appears of a piece with his horse; the latter seems flying off at all points.

It is often said with emphasis, that such a one has no seat on horseback; and it means, not only that he does not ride well, but that he does not sit on the right part of the horse. To have a good seat, is to sit on that part of the horse, which, as he springs, is the centre of motion; and from which, of course, any weight would be with most difficulty shaken. As in the rising and falling of a board placed in *aequilibrio*, the centre will be always most at rest; the true seat will be found in that part of your saddle, into which your body would naturally slide, if you rode without stirrups: and is only to be preserved by a proper poise of the body, though the generality of riders imagine it is to be done by the grasp of the thighs and knees. The rider should consider himself as united to his horse in this point; and when shaken from it, endeavour to restore the balance.

Perhaps the mention of the two extremes of a bad seat may help to describe the true one. The one is, when the rider sits very far back on the saddle, so that his weight presses the loins of the horse: the other, when his body hangs forward over the pommel of the saddle. The first may be seen practised by grooms, when they ride with their stirrups affectedly short; the latter, by fearful horsemen on the least flutter of the horse. Every good rider has, even on the hunting saddle, as determined a place for his thighs, as can be

Rules for
Bad
Horsemen.

determined for him by the bars of a demi-peak. Indeed there is no difference between the seat of either: only, as in the first you ride with shorter stirrups, your body will be consequently more behind your knees.

To have a good seat yourself, your saddle must sit well. To fix a precise rule might be difficult: it may be a *direction*, to have your saddle press as nearly as possible on that part which we have described as the point of union between the man and horse; however, so as not to obstruct the motion of the horse's shoulders. Place yourself in the middle or lowest part of it: sit erect; but with as little constraint as in your ordinary sitting. The ease of action marks the gentleman: you may repose yourself, but not lounge. The set and studied erectness acquired in the riding-house, by those whose deportment is not easy, appears ungentle and unnatural.

If your horse stops short, or endeavours by rising and kicking to unseat you, bend not your body forward, as many do in these circumstances: that motion throws the breech backward, and you off your fork or twist, and out of your seat; whereas, the advancing the lower part of your body, and bending back the upper part and shoulders, is the method both to keep your seat, and to recover it when lost. The bending your body back, and that in a great degree, is the greatest security in *flying* leaps; it is a security too, when your horse leaps *standing*. The horse's rising does not try the rider's seat; the lash of his hind legs is what ought chiefly to be guarded against, and is best done by the body's being greatly inclined back. Stiffen not your legs or thighs; and let your body be pliable in the loins, like the coachman's on his box. This loose manner of sitting will elude every rough motion of the horse; whereas the fixture of the knees, so commonly laid a stress on, will in great shocks conduce to the violence of the fall.

Was the cricket-player, when the ball is struck with the greatest velocity, to hold his hand firm and fixed when he receives it, the hand would be bruised, or perhaps the bones fractured by the resistance. To obviate this accident, he therefore gradually yields his hand to the motion of the ball for a certain distance; and thus by a due mixture of opposition and obedience, catches it without sustaining the least injury. The case is exactly the same in riding: the skilful horseman will recover his poise by giving some way to the motion; and the ignorant horseman will be flung out of his seat by endeavouring to be fixed.

Stretch not out your legs before you; this will push you against the back of the saddle; neither gather up your knees like a man riding on a pack; this throws your thighs upwards: each practice unseats you. Keep your legs straight down; and sit not on the most fleshy part of the thighs, but turn them inwards, so as to bring in your knees and toes: and it is more safe to ride with the ball of the foot pressing on the stirrup, than with the stirrup as far back as the heel: for the pressure of the heel being in that case behind the stirrup, keeps the thighs down.

When you find your thighs thrown upwards, widen your knees to get them and the upper part of your fork lower down on the horse. Grasp the saddle with the hollow or inner part of your thighs, but not more than

Rules for
Bad
Horsemen.

than just to assist the balance of your body: this will also enable you to keep your spurs from the horse's sides, and to bring your toes in, without that affected and useless manner of bringing them in practised by many. Sink your heels straight down; for while your heels and thighs keep down, you cannot fall: this (aided with the bend of the back) gives the security of a seat, to those who bear themselves up in their stirrups in a swift gallop, or in the alternate rising and falling in a full trot.

Let your seat determine the length of your stirrups, rather than the stirrups your seat. If more precision is requisite, let your stirrups (in the hunting saddle) be of such a length, as that, when you stand in them, there may be the breadth of four fingers between your seat and the saddle.

It would greatly assist a learner, if he would practise riding in a large circle, as directed sect. ii. without stirrups; keeping his face looking on the outward part of the circle so as not to have a full view of the horse's head, but just of that ear which is on the outward part of the circle; and his shoulder, which is towards the centre of the circle, very forward. By this means you learn to balance your body, and keep a true seat, independent of your stirrups: you may probably likewise escape a fall, should you at any time lose them by being accidentally shaken from your seat.

As the seat in some measure depends on the saddle, it may not be amiss to observe, that because a saddle with a high pommel is thought dangerous, the other extreme prevails, and the pommel is scarce allowed to be higher than the middle of the saddle. The saddle should lie as near the back-bone as can be, without hurting the horse; for the nearer you sit to his back, the better seat you have. If it does so, it is plain the pommel must rise enough to secure the withers from pressure: therefore, a horse whose withers are higher than common, requires a higher pommel. If, to avoid this, you make the saddle of a more straight line, the inconvenience spoken of follows; you sit too much above the horse's back, nor can the saddle form a proper seat. There should be no ridge from the button at the side of the pommel, to the back part of the saddle. That line also should be a little concave, for your thighs to lie at ease. In short, a saddle ought to be, as nearly as possible, as if cut out of the horse.

When you want your horse to move forward, raise his head a little, and touch him gently with your whip; or else, press the calves of your legs against his sides. If he does not move fast enough, press them with more force, and so till the spur just touches him. By this practice he will (if he has any spirit) move upon the least pressure of the leg. Never spur him by a kick; but if it be necessary to spur him briskly, keep your heels close to his sides, and slacken their force as he becomes obedient.

When your horse attempts to be vicious, take each rein separate, one in each hand, and advancing your arms forward, hold him very short. In this case, it is common for the rider to pull him hard, with his arms low. But the horse by this means having his head low too, has it more in his power to throw out his heels: whereas, if his head be raised very high, and his nose thrown out a little, which is consequent, he can nei-

Rules for
Bad
Horsemen.

ther rise before nor behind; because he can give himself neither of those motions, without having his head at liberty. A plank placed in *aequilibrio*, cannot rise at one end unless it sinks at the other.

If your horse is headstrong, pull not with one continued pull, but stop, and back him often, just shaking the reins, and making little repeated pulls till he obeys. Horses are so accustomed to bear on the bit when they go forward, that they are discouraged if the rider will not let them do so.

If a horse is loose-necked, he will throw up his head at a continued pull; in which situation, the rider, seeing the front of his face, can have no power over him. When your horse does thus, drop your hand and give the bridle play, and he will of course drop his head again into its proper place: while it is coming down, make a second gentle pull, and you will find his mouth. With a little practice, this is done almost instantaneously; and this method will stop, in the distance of a few yards, a horse, which will run away with those who pull at him with all their might. Almost every one must have observed, that when a horse feels himself pulled with the bridle, even when he is going gently, he often mistakes what was designed to stop him, as a direction to bear on the bit and to go faster.

Keep your horse's head high, that you may raise his neck and crest; play a little with the rein, and move the bit in his mouth, that he may not press on it in one constant and continued manner: be not afraid of raising his head too high; he will naturally be too ready to bring it down, and tire your arms with its weight, on the least abatement of his mettle. When you feel him heavy, stop him, and make him go back a few paces: thus you break by degrees his propensity to press on his bridle.

You ought not to be pleased (though many are) with a round neck, and a head drawn in towards his breast: let your horse carry his head bridling in, provided he carries it high, and his neck arching upwards; but if his neck bends downwards, his figure is bad, his sight is too near his toes, he leans on the bridle, and you have no command over him. If he goes pressing but lightly on the bridle, he is the more sure-footed, and goes pleasanter; as your wrist only may guide him. If he hangs down his head, and makes you support the weight of that and his neck with your arms bearing on his fore-legs, (which is called *being on his shoulders*), he will strike his toes against the ground, and stumble.

If your horse is heavy upon the bit, tie him every day, for an hour or two, with his tail to the manger, and his head as high as you can make him lift it, by a rein on each post of the stall, tied to each ring of the snaffle bit.

Horse-breakers and grooms have a great propensity to bring a horse's head down, and seem to have no seat without a strong hold by the bridle. They know indeed, that the head should yield to the reins, and the neck form an arch; but do not take the proper pains to make it an arch upward. A temporary effect of attempting to raise a horse's head, may perhaps be making him push out his nose. They will bare tell you, that his head is too high already; whereas it is not the distance from his nose, but from the top of his head

Rules for
Bad
Horsemen.

head to the ground, which determines the head to be high or low. Besides, although the fault is said to be in the manner of carrying the head, it should rather be said to be in that of the neck; for if the neck was raised, the head would be more in the position of one set on a well formed neck.

The design therefore of lifting up the head, is to raise the neck, and *thereby* bring in the head; for even while the bridle makes the same line from the rider's hand to the bit, the horse's nose may be either drawn in, or thrust out, according as his neck is raised or depressed. Instead of what has been here recommended, we usually see colts broke with their heads cavassoned very low, their necks stiff, and not in the least suppld. When the breaking-tackle is left off, and they are mounted for the road, having more food and rest, they frequently plunge, and a second breaking becomes necessary. Then, as few gentlemen can manage their own horses, they are put into the hands of grooms, from whom they learn a variety of bad habits.

If, on the other hand, your horse carries his head (or rather his nose) too high, he generally makes some amends by moving his shoulders lightly, and going safely. Attend to the cause of this fault. Some horses have their necks set so low on their shoulders, that they bend first down, then upwards, like a stag's. Some have the upper line of their necks, from their ears to their withers, too short. A head of this sort cannot possibly bend inwards and form an arch, because the vertebræ (or neck bones) are too short to admit of flexure; for in long and short-necked horses the number of the vertebræ is the same. In some, the jaw is so thick, that it meets the neck, and the head by this means has not room to bend. On the other hand, some have the under line from the jaw to the breast so short, that the neck cannot rise.

In all these cases you may gain a *little* by a nice hand with an easy bit; but no curb, martingale, or other forcible method, will *teach* a horse to carry his head or neck in a posture which nature has made uneasy to him. By trying to pull in his nose farther than he can bear, you will add a bad habit to nature. You could not indeed *contrive* a more effectual method to make him continually toss his nose up, and throw his foam over you.

The rule already given to ride a loose-necked horse, will be a proper one for all light-mouthed horses; one caution being added, which is, always to search whether his saddle or girths may not in some way pinch him; and whether the bit may not hurt his lip by being too high in his mouth: because, whenever he frets from either of these causes, his head will not be steady.

It is a common custom to be always pulling at the bridle, as if to set off to advantage either the spirit of the horse, or the skill of the rider. Our horses therefore are taught to hold their heads low, and pull so as to bear up the rider from the saddle standing in his stirrups, even in the gentlest gallop: how very improper is this, we are experimentally convinced, when we happen to meet with a horse which gallops otherwise. We immediately say, *he canters excellently*, and find the ease and pleasure of his motion. When horses are de-

Rules for
Bad
Horsemen.

signed for the race, and swiftness is the only thing considered, the method may be a good one.

It is not to be wondered that *dealers* are always pulling at their horses, that they have the spur constantly in their sides, and are at the same time continually checking the rein: by this means they make them bound, and champ the bit, while their rage has the appearance of spirit. These people ride with their arms spread, and very low on the shoulders of their horses: this method makes them stretch their necks, and gives a better appearance to their fore-hands; it conceals also a thick jaw, which, if the head was up, would prevent its yielding to the bit; it hides likewise the ewe-neck, which would otherwise show itself. Indeed, if you have a horse unsteady to the bit, formed with a natural heavy head, or one which carries his nose obstinately in the air, you must find his mouth where you can, and make the best of him.

Many horses are taught to start, by whipping them for starting. How is it possible they can know it is designed as a punishment? In the riding-house, you teach your horse to rise up before, and to spring and lash out his hinder legs, by whipping him when tied between two pillars, with his head a little at liberty. If he understood this to be a punishment for doing so, he would not by that method learn to do it. He seems to be in the same manner *taught* to spring and fly when he is frightened. Most horses would go quietly past an object they were beginning to fly from, if their riders, instead of gathering up their bridles, and showing themselves so ready, should throw the reins loose upon their necks.

When a horse starts at any thing on one side, most riders turn him out of the road, to make him go up to what he starts at: if he does not get the better of his fear, or readily comply, he generally goes past the object, making with his hinder parts, or croup, a great circle out of the road; whereas, he should learn to keep straight on, without minding objects on either side.

If he starts at any thing on the left, hold his head high, and keep it straight in the road, pulling it *from* looking at the thing he starts at, and keeping your right leg hard pressed against his side, towards his flank: he will then go straight along the road. By this method, and by turning his head a little more, he may be forced with his croup close up to what frightened him; for as his head is pulled one way, his croup necessarily turns the other. Always avoid a quarrel with your horse, if you can: if he is apt to start, you will find occasions enough to exercise his obedience, when what he starts at lies directly in his way, and you *must* make him pass; if he is not subject to start, you should not quarrel with him about a trifle.

It must be observed, however, that this rule in going past an object may perhaps be a little irregular in a managed horse, which will always obey the leg: but even such a horse, if he is really afraid, and not restive, it may not be amiss to make look another way; unless the object be something you would particularly accustom him to the sight of.

The case will also be different with a horse whose fear is owing to his being not used to objects; but such

Rules for
Bad
Horsemen.

such a one is not to be rode by any horseman to whom these rules are directed: the starting here meant arises merely from the horse's being pampered, and springing through liveliness.

The notion of the necessity of making a horse go immediately up to every thing he is afraid of, and not suffering him to become master of his rider, seems to be in general carried too far. It is an approved and good method to conquer a horse's fear of the sound of a drum, by beating one near to him at the time of feeding him: this not only familiarizes the noise to him, but makes it pleasant, as a fore-runner of his meat*; whereas, if he was whipped up to it, he might perhaps start at it as long as he lived. Might not this be applied to his starting at other things, and show that it would be better to suffer him (provided he does not turn back) to go a little from and avoid an object he has a dislike to, and to accustom him to it by degrees, convincing him, as it were, that it will not hurt him; than to punish him, quarrel with him, and perhaps submit to his will at last, while you insist on his overcoming his fear in an instant? If he sees a like object again, it is probable he will recollect his dread, and arm himself to be disobedient.

* See
Sect. v.

We are apt to suppose that a horse fears nothing so much as his rider; but may he not, in many circumstances, be afraid of instant destruction? of being crushed? of being drowned? of falling down a precipice? Is it a wonder that a horse should be afraid of a loaded waggon? may not the hanging load seem to threaten the falling on him? There cannot be a rule more general, than, in such a case, to shew him there is room for him to pass. This is done by turning his head a very little from the carriage, and pressing your leg, which is farthest from it, against his side.

A horse is not to stop without a sign from his rider.—Is it not then probable, that when driven up to a carriage he starts at it, he conceives himself obliged either to attack or run against it? Can he understand the rider's spurring him with his face directed to it, as a sign for him to pass it? That a horse is easily alarmed for his face and eyes (he will even catch back his head from a hand going to caress him); that he will not go with any force, face to face, even to another horse (if in his power to stop); and that he sees perfectly sideways,—may be useful hints for the treatment of horses with regard to starting.

Though you ought not to whip a horse for starting, there can be no good effect from clapping his neck with your hand to encourage him. If one took any notice of his starting, it should be rather with some tone of voice which he usually understood as an expression of dislike to what he is doing; for there is opposition mixed with his starting, and a horse will ever repeat what he finds has foiled his rider.

Notwithstanding the directions above given, of not pressing a horse up to a carriage he starts at; yet if one which you apprehend will frighten him meets you at a narrow part of the road, when you have once let him know he is to pass it, be sure you remain determined, and press him on. Do this more especially when part of the carriage has already passed you: for if, when he is frightened, he is accustomed to go back, and turn round, he will certainly do it if he finds, by your hand slackening, and legs not pressing,

that you are irresolute; and this at the most dangerous point of time, when the wheels of the carriage take him as he turns. Remember not to touch the curb rein at this time; it will certainly check him. It is not known to every one, that the person who would lead a horse by the bridle, should not turn his face to him when he refuses to follow him: if, besides this, he raises his arms, shows his whip, or pulls the bridle with jerks, he frightens the horse, instead of persuading him to follow; which a little patience may bring about.

Ride with a snaffle; and use your curb, if you have one, only occasionally. Choose your snaffle full and thick in the mouth, especially at the ends to which the reins are fastened. Most of them are made too small and long; they cut the horse's mouth, and bend back over the bars of his jaw, working like pincers.

The management of the curb is too nice a matter to enter on here, farther than to prescribe great caution in the use of it: a turn of the wrist, rather than the weight of your arm, should be applied to it. The elasticity of a rod, when it hath hooked a fish, may give you some idea of the proper play of a horse's head on his bridle; his spirit and his pliability are both marked by it.

A horse should never be put to do any thing in a curb which he is not ready at: you may force him, or pull his head any way with a snaffle; but a curb acts only in a straight line. It is true, that a horse will be turned out of one track into another by a curb, but it is because he knows it as a *signal*. When he is put to draw a chair and does not understand the necessity he is then under of taking a larger sweep when he turns, you frequently see him *restive*, as it is then called: but put him on a snaffle, or buckle the rein to that part of the bit which does not curb him; and the horse submits to be pulled about, till he understands what is desired of him. These directions suppose your horse to have spirit, and a good mouth; if he has not, you must take him as he is, and ride him with such a bit as you find most easy to yourself.

When you ride a journey, be not so attentive to your horse's nice carriage of himself, as to your encouragement of him, and keeping him in good humour. Raise his head; but if he flags, you may indulge him with bearing a little more upon the bit than you would suffer in an airing. If a horse is lame, tender-footed, or tired, he naturally hangs upon his bridle. On a journey, therefore, his mouth will depend greatly on his strength and the goodness of his feet. Be then very careful about his feet, and let not a farrier spoil them. You will be enabled to keep them from danger, by the directions given under the article FARRIER.

Very few, although practised in riding, know they have any power over a horse but by the bridle; or any use for the spur, except to make him go forward. A little experience will teach them a farther use. If the left spur touches him (and he is at the same time prevented from going forward), he has a sign, which he will soon understand, to move sidewise to the right. In the same manner to the left, if the right spur is closed to him: he afterwards, through fear of the

Rules
Bad
Horsemen.

Rules for
Bad
Horsemen.

spur, obeys a touch of the leg; in the same manner as a horse moves his croup from one side of the stall to the other, when any one strikes him with his hand. In short, his croup is guided by the leg, as his head is by the bridle. He will never disobey the leg, unless he becomes restive. By this means you will have a far greater power over him; he will move sidewise, if you close one leg to him; and straight forward, if both: even when he stands still, your legs held near him will keep him on the watch; and with the slightest motion of the bridle upwards, he will raise his head, and show his forehead to advantage.

On this use of the legs of the rider, and guidance of the croup of the horse, are founded all the *airs* (as the riding-masters express themselves) which are taught in the manege; the passage, or side-motion of troopers to close or open their files, and indeed all their evolutions. But the convenience of some degree of this discipline for common use is the reason of mentioning it here. It is useful if a horse is apt to stumble or start. If to the first, by pressing your legs to his flank, and keeping up his head, he is made to go light on his fore-legs, which is aiding and supporting him; and the same if he does actually stumble, by helping him at the very instant to exert himself, while as yet any part of him remains not irrecoverably impressed with the precipitate motion. Hence this use of the hand and legs of the rider is called *giving aids* to a horse; for, as to holding up the weight of a heavy unactive horse, by mere pulling, it is as impossible as to recover him when falling down a precipice.

A horse is supported and helped by the hands and legs of his rider in every action they require of him; hence he is said to perform his *airs* by the *aids* from his rider.

The same manner is useful if a horse starts. For if when he is beginning to fly to one side, you leg on the side he is flying to, he stops his spring immediately. He goes past what he started at, keeping straight on, or as you choose to direct him; and he will not fly back from any thing if you press him with both legs. You keep his haunches under him, going

down a hill; help him on the side of a bank; more easily avoid the wheel of a carriage; and approach more gracefully and nearer to the side of a coach or horseman. When a pampered horse curvets irregularly, and twists his body to and fro, turn his head either to the right or left, or both alternately (but without letting him move out of the track), and press your leg to the opposite side: your horse cannot then spring on his hind-legs to one side, because your leg prevents him; nor to the other, because his head looks that way, and a horse does not start and spring to the side on which he looks. Here it may not be amiss to observe the impropriety of the habit which many riders have, of letting their legs shake against the sides of the horse: if a horse is taught, they are then continually pressing him to violent action; and if he is not, they render him insensible and incapable of being taught. The fretting of a hot horse will hence be excessive, as it can no otherwise be moderated than by the utmost stillness of the seat, hands, and legs of the rider.

Colts at first are taught to *bear* a bit, and by degrees to *pull* at it. If they did not press it, they could not be guided by it. By degrees they find their necks stronger than the arms of a man; and that they are capable of making great opposition, and often of foiling their riders. Then is the time to make them supple and pliant in every part. The part which of all others requires most this pliancy is the neck. Hence the metaphor of *stiff-necked* for *disobedient*. A horse cannot move his head but with the muscles of his neck: this may be called his *helm*; it guides his course, changes and directs his motion.

The use of this pliancy in the different parts and limbs of a horse has been already shown in a former section. The present section being directed to the *inexperienced* horseman, it may suffice to add that *his* idea of suppleness need only be, that of an ability and readiness in a horse to move every limb, on a sign given him by the hands or legs of his rider; as also to bend his body, and move in a short compass, quick and collected within himself, so as instantly to be able to perform any other motion.

Rules for
Bad
Horsemen.

H O R

Horsham.

HORSHAM, a town of Sussex, seated near St Leonard's forest, 38 miles from London. It has its name from *Horsa*, brother to Hengist the Saxon; and is one of the largest towns in the county. It has sent members to parliament ever since the 30th of Edw. I. and is the place where the county-gaol is held, and often the assizes. It is a borough by prescription, with the title of two bailiffs and burgage-holders within and without the borough, &c. who elect the members of parliament, and they are returned by the bailiffs chosen yearly by a court-leet of the lord of the manor, who return four candidates to the steward, and he nominates two of them for the office. Here is a very fine church, and a well endowed free-school. Great store of poultry is bought up for London at its market on Saturday, and it has a

VOL. X. Part II.

†

H O R

patent also for a monthly market. In 1811, the number of inhabitants was 3839.

HORTALIGERS, in the grand signior's court, upholsterers, or tapestry-hangers, who go always a day's journey before the grand signior, to fix upon a proper place for his tent, which they prepare first; and afterwards those of the officers, according to their rank.

HORTENSIUS, QUINTUS, a celebrated Roman orator, the contemporary of Cicero, pleaded with universal applause at 19 years of age, and continued the same profession during 48 years. But being at last eclipsed by Cicero, he quitted the bar, and embraced a military life: became a military tribune, prætor, and afterwards consul about 80 B. C. Cicero speaks of him in such a manner as makes us regret the loss

Horsham
Hortensius.

4 K

of

Hortensius, of his orations. *Hortensius* had a wonderful memory, and delivered his orations without writing down a single word, or forgetting one particular that had been advanced by his adversaries. He died very rich, a little before the civil war, which he had endeavoured by all possible means to prevent.

HORTICULTURE, the art of cultivating fruits, flowers, and various esculent plants, being the same as gardening. See **SUPPLEMENT**.

HORTUS SICCUS, a **DRY GARDEN**; an appellation given to a collection of specimens of plants, carefully dried and preserved.

The value of such a collection is very evident, since a thousand minutiae may be preserved in well-dried specimens of plants, which the most accurate engraver would overlook. We shall therefore give two methods of drying and preserving a *hortus siccus*; the first by Sir Robert Southwell in the Philosophical Transactions, N^o 237.; and the other by Dr Hill, in his review of the works of the Royal Society, with his objections to Sir Robert's method.

According to the former gentleman, the plants are to be laid flat between papers, and then put between two smooth plates of iron, screwed together at the corners; and in this condition committed to a baker's oven for two hours. When taken out, they are to be rubbed over with a mixture of equal parts of aquafortis and brandy; and after this to be fastened down on paper with a solution of the quantity of a walnut of gum tragacanth dissolved in a pint of water. See **HERBAL**.

To this the Doctor objects, that the heat of an oven is much too uncertain to be employed in so nice an operation; and that the space of time ordered for continuing the plants in it is of no information, unless the degree of heat, and even the different nature of the plant as to its succulency and the firmness or tenderness of its fibres, be attended to; there being scarcely any two plants alike in these particulars: consequently the degree and duration of heat sufficient for one plant would destroy another. Beside which, the acid used destroys the colour of many plants; and never recovers that of others lost in the dyeing; and frequently after the plant is fixed down, rots both the paper it is fixed to, and that which falls over it. Dr Hill's method is as follows. Take a specimen of a plant in flower, and with it one of its bottom leaves if it have any; bruise the stalk if too rigid, or slit it if too thick: spread out the leaves and flowers on paper, cover it with more paper, and lay a weight over all. At the end of 18 hours take out the plants, now perfectly flattened, and lay them on a bed of dry common sand; sift more dry sand over them to the depth of two inches, and thus let them lie about three weeks: the less succulent dry much sooner, but they take no harm afterward. If the floor of a garret be covered in spring with sand two inches deep, leaving space for walking to the several parts, it will receive the collection of a whole summer; the covering of sand being sifted over every parcel as laid in, they need no farther care from the time of laying them till they are taken up to be stuck on paper. The cement used by the Doctor is thus prepared: early in the spring, put two ounces of camphor into three quarts of water in a large bottle; shake it from time to time, and when the

first collected plants are ready for the fastening down, put into a pint of the water, poured off into an earthen vessel that will bear the fire, two ounces of common glue, such as is used by the carpenters, and the same quantity of ichthyocolla beat to sbreds: let them stand 36 hours, then gently boil the whole a few moments, and strain it off through a coarse cloth: this is to be warmed over a gentle heat when it is to be used, and the back of the plants smeared over with a painter's brush: after this lay them on paper, and gently press them for a few minutes, then expose them to the air a little; and finally lay them under a small weight between quires of paper to be equally dried.

It is scarce to be conceived how strongly the water becomes impregnated with the camphor by this simple process: a part of it indeed flies off in the making of the cement and the using of it: but enough remains with the plants to prevent the breeding of insects in it. He farther observes, that plants may be dried very well without sand, by only putting them frequently into fresh quires of paper, or a few, by only pressing them between the leaves of a book: but the sand method preserves the colour best, and is done with least trouble.

Another method much better than that of the oven is the flattening and drying the plant by passing a common smoothing iron for linen over the papers between which it is laid; but for nice things the most perfect of all methods is that by a common sand heat, such as is used for chemical purposes. The cold sand is to be spread smooth upon this occasion, the plant laid on it carefully flatted, and a thick bed of sand sifted over: the fire is then to be made, and the whole process carefully watched until by a very gentle heat the plant be carefully dried. The colour of the tenderest herb may by this manner be preserved; and flowers, that can no way else be preserved, may be managed perfectly well thus.

HORUS, a renowned deity of ancient Egypt. He was an emblem of the sun. Plutarch (in his treatise *de Iside et Osiride*) says, "that virtue which presides over the sun, whilst he is moving through space, the Egyptians called *Horus* and the Greeks *Apollo*." Job also calls *Ur* or *Orus* the sun—"If I gazed upon the sun (*Ur*, *Orus*) when he was shining, or on (*Järtcha*) the moon walking in brightness, and my heart hath been secretly enticed (i. e. to worship), or my mouth hath kissed my hand; this also were an iniquity to be punished by the judge, for I should have denied the God who is above." Chap. xxxi. ver. 26, 27, 28.

The interpretation left by Hermapion of the hieroglyphics engraved on the obelisk of Heliopolis (according to Ammianus Marcellinus), offers these remarkable words: "Horus is the supreme lord and author of time." These qualities, it is known, were chiefly attributed to Osiris: that they may apply, therefore, to Horus, he must necessarily denote the star of the day in certain circumstances; and this is what is explained to us by the oracle of Apollo of Claros:

Learn that the first of the gods is *Jao*.

He is called *invisible* in winter, *Jupiter* in the spring, *The sun* in summer, and towards the end of autumn the tender *Jao*.

The star of the day, on attaining the summer solstice, and called *per excellentiam* the Sun, is the same as *Horus*.

Horus. rus. In fact, the Egyptians represented him borne on lions, which signified his entrance into the sign of the lion. They who presided over the divine institutions, then placed sphynxes at the head of the canals and sacred fountains, to warn the people of the approaching inundation. Macrobius *, who informs us why the Greeks gave Horus the name of Apollo, confirms this sentiment : " In the mysteries (says he) they discover as a secret, which ought to be inviolable, that the sun arrived in the upper hemisphere, is called Apollo." These testimonies concur in proving, that this emblematical deity was no other than the star of day, passing through the signs of summer.

Saturnal. b. i. These lights may lead us to the explication of the sacred fable, which the priests published on the subject of Horus ; for they enveloped in mystery every point of their religion. Plutarch gives it at length in his treatise of Isis and Osiris : The following are the principal traits. They said that he was the son of Osiris and of Isis ; that Typhon, after killing his brother Osiris, took possession of the kingdom ; that Horus, leaguering himself with Isis, avenged the death of his father, expelled the tyrant from his throne without depriving him of life, and reigned gloriously in Egypt. A person who has travelled ever so little in Egypt easily discovers natural phenomena hid under the veil of fable. In the spring, the wind khamsia frequently makes great ravages there. It raises whirlwinds of burning sand, which suffocate travellers, darken the air, and cover the face of the sun in such a manner as to leave the earth in perfect obscurity. Here is the death of Osiris and the reign of Typhon. These hurricanes break out usually in the months of February, March, and April. When the sun approaches the sign of the lion, he changes the state of the atmosphere, disperses these tempests, and restores the northerly winds, which drive before them the malignant vapours, and preserve in Egypt coolness and salubrity under a burning sky. This is the triumph of Horus over Typhon, and his glorious reign. As the natural philosophers acknowledge the influence of the moon over the state of the atmosphere, they united her with this god, to drive the usurper from the throne. The priests considering Osiris as the father of time, might bestow the name of his son on Horus, who reigned three months in the year. This, according to Mr Savary †, is the natural explication of this allegory. And all enlightened men, he thinks, must have understood this language, which was familiar to them. The people only, whose feeble sight extends no farther than the exterior, without diving into the true meaning of things, might regard these allegorical personages as real gods, and decree prayers and offerings to them.

Letters Egypt. 403. Jablonski, who has interpreted the epithet of Arueri, which the Egyptians gave to Horus, pretends that it signifies *efficacious virtue*. These expressions perfectly characterise the phenomena which happened during the reign of this god. It is in summer, in fact, that the sun manifests all its power in Egypt. It is then that he swells the waters of the rivers with rains, exhaled by him in the air, and driven against the summits of the Abyssinian mountains ; it is then that the husbandman reckons on the treasures of agriculture. It was natural for them to honour him with the name of

Arueri, or *efficacious virtue*, to mark these auspicious effects.

HOSANNA, in the Hebrew ceremonies, a prayer which they rehearsed on the several days of the feast of tabernacles. It was thus called, because there was frequent repetition therein of the word *הושיענו*, *serva nunc*, or *serva precor* ; i. e. save us now ; or save us, we pray.

There are divers of these hosannas. The Jews call them *hoschannoth* ; i. e. the *hosannas*. Some are rehearsed on the first day, others on the second, &c. which they called *hosanna* of the first day, *hosanna* of the second day, &c.

Hosanna Rabba, or *Grand Hosanna*, is a name they give to their feast of tabernacles, which lasts eight days ; because during the course thereof, they are frequently calling for the assistance of God, the forgiveness of their sins, and his blessing on the new year ; and to that purpose they make great use of the *hoschannoth*, or prayers above mentioned.—The Jews also applied the term *hosanna rabba*, in a more peculiar manner, to the seventh day of the feast of tabernacles ; because they apply themselves more immediately on that day to invoke the divine blessing, &c.

HOSE, from the Saxon *Hosa*, a stocking. See **STOCKING**.

HOSEA, the first in number of the minor Hebrew prophets, as arranged in the Hebrew and Greek bibles, although probably the third in a chronological sense. He was the son of Beeri, but it is uncertain to what tribe he belonged. He prophesied in the reigns of Uzziab, Jotham, Ahaz, and Hezekiah, kings of Judah, and in the time of Jeroboam, who was king of Israel. If he uttered predictions during 66 years, between 790 and 724 before Christ, then he discharged the office of a sacred seer eight years during the reign of Jeroboam II. 33 in the reign of Uzziab, the entire reigns of Jotham and Ahaz, and three years in the reign of Hezekiah ; but could not have survived the taking of Samaria. He reproved the vices of kings as well as their subjects, mixing threatenings of divine vengeance with promises of pardon in consequence of repentance. His style is concise, sententious, and abrupt. His short and lively comparisons are numerous. He is sometimes distinguished by great force of expression, has many beautiful passages, and in some parts is truly sublime. Dr Newcome was of opinion that the chief difficulty in understanding this prophet is owing to the corrupt readings which disfigure the printed text, and these he freely corrected from the collations of Dr Kennicott. On the other hand, Dr Horsley protests earnestly against Dr Newcome's opinion, declaring that the corruptions can be no cause of obscurity ; but we must leave it to our readers to determine which of these two great men is in the right, from an attentive perusal of their own works, assured that they will decide in favour of him who furnishes the best helps for understanding this prophet.

HOSPINIAN, RODOLPHUS, one of the greatest writers that Switzerland has given birth to. He was born in 1547, at Altorf near Zurich ; obtained the freedom of Zurich ; and was made provisor of the abbey-school. Notwithstanding this employment, he undertook a noble work of vast extent, which was a *History of the Errors of Popery*. Though he could

Hospinian,
Hospital.

not complete this work according to his plan, he published some considerable parts of it: what he published on the Eucharist, and another work called *Concordia Discors*, exceedingly exasperated the Lutherans. He did not reply to them; but turning his arms against the Jesuits, published *Historia Jesuitica*, &c. These writings gained him preferment; he being appointed archdeacon of Caroline church, and then minister of the abbey-church. He died in 1626; and there was an edition of his works published at Geneva 1681, in seven volumes in folio.

HOSPITAL, popularly **SPITTAL**, a place or building erected, out of charity, for the reception and support of the poor, aged, infirm, sick, and otherwise helpless. The word is formed of the Latin *hospes*, "host, stranger." See **HOST**.

In the early ages of the church, the bishop had the immediate charge of all the poor, both sound and diseased, as also of widows, orphans, strangers, &c.—When the churches came to have fixed revenues allotted them, it was decreed, that at least one-fourth part thereof should go to the relief of the poor; and to provide for them the more commodiously, divers houses of charity were built, which are since denominated *hospitals*. They were governed wholly by the priests and deacons, under the inspection of the bishop. In course of time, separate revenues were assigned for the hospitals; and particular persons, out of motives of piety and charity, gave lands and money for erecting of hospitals. When the church discipline began to relax, the priests, who till then had been the administrators of hospitals, converted them into a sort of benefices, which they held at pleasure, without giving account thereof to any body; reserving the greatest part of the income to their own use; so that the intentions of the founders were frustrated.—To remove this abuse, the council of Vienne expressly prohibited the giving any hospital to secular priests in the way of a benefice; and directed the administration thereof to be given to sufficient and responsible laymen, who should take an oath, like that of tutors, for the faithful discharge thereof, and be accountable to the ordinaries.—This decree was executed and confirmed by the council of Trent.

In Britain, hospitals are buildings properly endowed, or otherwise supported by charitable contributions, for the reception and support of the poor, aged, infirm, sick, or helpless.

A charitable foundation laid thus for the sustenance and relief of the poor is to continue for ever. Any person seized of an estate in fee, may, by deed inrolled in chancery, erect and found an hospital, and nominate such heads and governors therein as he shall think fit; and this charitable foundation shall be incorporated, and subject to the inspection and guidance of the heads and visitors nominated by the founder. Likewise such corporations shall have, take, and purchase lands, so as not to exceed 200l. a year, provided the same be not held of the king; and to make leases, reserving the accustomed yearly rent. See **CORPORATION**.

HOSPITAL, MICHAEL DE L', chancellor of France in the 16th century, was one of the greatest men of his age, and had raised himself by degrees. He agreed to an edict much severer against the Protestants than

he could have wished, to prevent the introduction of the inquisition. It was that of Romorantin. The speeches he made, in order to inspire a spirit of toleration, made him much suspected by the Roman Catholics, and extremely odious to the court of Rome. The maxims of state upon which he regulated himself were of great advantage to France, since he formed some disciples who opposed, in proper time, the pernicious attempts of the leaguers, and rendered them abortive. His pacific views being disliked by Catharine de Medicis, who had contributed to his advancement, she excluded him from the council of war, and occasioned his disgrace. He retired, however, of his own accord, in 1568; and spent the rest of his life at his country-seat at Vignai, where he died in 1573, aged 68. His poems are esteemed. He also published some excellent speeches and memoirs.

HOSPITAL, William-Francis-Antony, Marquis of, a great mathematician of France, was born of an ancient family in 1661. He was a geometrician almost from his infancy; for one day being at the duke of Rohan's, where some able mathematicians were speaking of a problem of Pascal's which appeared to them extremely difficult, he ventured to say, that he believed he could solve it. They were amazed at such presumption in a boy of 15, for he was then no more; nevertheless, in a few days he sent them the solution. He entered early into the army, and was a captain of horse; but being extremely short-sighted, and exposed on that account to perpetual inconveniences and errors, he at length quitted the army, and applied himself entirely to his favourite amusement. He contracted a friendship for Malebranche, and took his opinion upon all occasions. In 1693, he was received an honorary member of the academy of sciences at Paris; and he published a work upon Sir Isaac Newton's calculations, entitled, *L'Analyse des infinimens petits*. He was the first in France who wrote upon this subject; and on this account was regarded almost as a prodigy. He engaged afterwards in another work of the mathematical kind, in which he included *Les Sections Coniques, les Lieux Geometriques, la Construction des Equations, et Une Theorie des Courbes Mechaniques*: but a little before he had finished it, he was seized with a fever, of which he died Feb. 2. 1704, aged 43. It was published after his death.

HOSPITALITY, the practice of entertaining strangers. Dr Robertson, speaking of the middle ages, says, "Among people whose manners are simple, and who are seldom visited by strangers, hospitality is a virtue of the first rank. This duty of hospitality was so necessary in that state of society which took place during the middle ages, that it was not considered as one of those virtues which men may practise or not, according to the temper of their minds and the generosity of their hearts. Hospitality was enforced by statutes, and those who neglected the duty were liable to punishment. The laws of the Salvi ordained that the moveables of an inhospitable person should be confiscated, and his house burnt. They were even so solicitous for the entertainment of strangers, that they permitted the landlord to steal for the support of his guest."

The hospitality of our British ancestors, particularly of the great and opulent barons, hath been much admired,

Hospitality, mired, and considered as a certain proof of the nobleness and generosity of their spirits. The fact is well attested. The castles of the powerful barons were capacious palaces, daily crowded with their numerous retainers, who were always welcome to their plentiful tables. They had their privy counsellors, their treasurers, marshals, constables, stewards, secretaries, chaplains, heralds, pursuivants, pages, henchmen or guards, trumpeters, minstrels, and in a word all the officers of a royal court. The etiquette of their families was an exact copy of that of the royal household; and some of them lived in a degree of pomp and splendour little inferior to that of the greatest kings. Richard Neville, earl of Warwick, we are told, "was ever had in great favour of the commons of the land, because of the exceeding household which he daily kept in all countries wherever he sojourned or lay: and when he came to London, he held such an house, that six oxen were eaten at a breakfast; and every tavern was full of his meat." The earls of Douglas in Scotland, before the fall of that great family, rivalled or rather exceeded their sovereigns in pomp and profuse hospitality. But to this manner of living it is highly probable these great chieftains were prompted by a desire of increasing the number and attachment of their retainers, on which, in those turbulent times, their dignity, and even their safety, depended, as much as to the innate generosity of their tempers. Those retainers did not constantly reside in the families of their lords; but they wore their liveries and badges, frequently feasted in their halls, swelled their retinues on all great solemnities, attended them in their journeys, and followed them into the field of battle. Some powerful chieftains had so great a number of these retainers constantly at their command, that they set the laws at defiance, were formidable to their sovereigns, and terrible to their fellow-subjects; and several laws were made against giving and receiving liveries. But these laws produced little effect in this period.

Hospitality was not confined to the great and opulent, but was practised rather more than it is at present by persons in the middle and lower ranks of life. But this was owing to necessity, arising from the scarcity of inns, which obliged travellers and strangers to apply to private persons for lodging and entertainment; and those who received them hospitably acquired a right to a similar reception. This was evidently the case in Scotland in the first part of this period. James I. A. D. 1424, procured the following act of parliament. "It is ordanit, That in all burrow townis, and throuchfairis quhair commoun passages ar, that thair be ordanit hostillaries and resettis, havand stables and chalmers; and that men find with thame bread and aill, and all uther sude, alsweil for horse as men, for resonable price." But travellers had been so long accustomed to lodge in private houses, that these public inns were quite neglected; and those who kept them presented a petition to parliament, complaining, "That the liegis travelland in the realme, quhen they cum to burrowis and throuchfairis, herbreis thame not in hostillaries, bot with thair acquaintance and freindis." This produced an act prohibiting travellers to lodge in private houses where there were hostlaries, under the penalty of 40s. and subjecting those who lodged them to the same penalty.

The inhabitants of the Highlands and the Western Isles were remarkable for their hospitality and kindness to strangers, and still retain the same disposition. See **HIGHLANDERS**. Hospitality
||
Host.

HOSPITALLERS, HOSPITALARI, an order of religious knights, who built an hospital at Jerusalem, wherein pilgrims were received. To these Pope Clement V. transferred the effects and revenues of the Templars; whom, by a council held at Vienne, he suppressed for their many and great misdemeanours. These hospitallers were otherwise called Knights of St John of Jerusalem; and are the same with those whom we now call Knights of Malta.

HOSPITIUM, a term used in old writers either for an inn or a monastery, built for the reception of strangers and travellers. See INN and MONASTERY.

HOSPODAR, a title borne by the princes of Walachia and Moldavia, who receive the investiture of their principalities from the grand signior. He gives them a vest and standard; they are under his protection, and obliged to serve him, and he even sometimes deposes them; but in other respects they are absolute sovereigns within their own dominions.

HOST, HOSPE, a term of mutual relation, applied both to a person who lodges and entertains another, and to the person thus lodged, &c.—The word is formed of the Latin hospes, which some will have thus called quasi hostium or ostium petens; for ostium was anciently written with an aspirate.—Thus the innkeeper says, he has a good host, in speaking of the traveller who lodges with him; and the traveller, again, says, he has a kind host, in speaking of his landlord.

It must be observed then, that it was the custom among the ancients, when any stranger asked for lodging, for the master of the house, and the stranger, each of them to set a foot on their own side of the threshold, and swear they would neither of them do any harm to the other. It was this ceremony that raised so much horror against those who violated the law or right of hospitality on either side; inasmuch as they were looked on as perjured.

Instead of *hospes*, the ancient Latins called it *hostis*; as Cicero himself informs us: though, in course of time, *hostis* came to signify an enemy; so much was the notion of hospitality altered.

HOST is also used by way of abbreviation for *hostia*, a victim or sacrifice offered to the Deity. In this sense, *host* is more immediately understood of the person of the Word incarnate, who was offered up an host or *hostia* to the Father on the cross for the sins of mankind. See **HOSTIA**.

HOST, in the church of Rome, a name given to the elements used in the eucharist, or rather to the consecrated wafer; which they pretend to offer up every day a new host or sacrifice for the sins of mankind.—They pay adoration to the host, upon a false presumption that the elements are no longer bread and wine, but transubstantiated into the real body and blood of Christ. See **TRANSUBSTANTIATION**.—Pope Gregory IX. first decreed a bell to be rung, as the signal for the people to betake themselves to the adoration of the host.—The vessel wherein the hosts are kept is called the *cibory*; being a large kind of covered chalice.

Hostage
Hot-beds.

HOSTAGE, a person given up to an enemy as a security for the performance of the articles of a treaty.

HOSTIA, **HOST**, in antiquity, a victim offered in sacrifice to a deity.

The word is formed from *hostis*, "enemy;" it being the custom to offer up a sacrifice before they joined battle, to render the gods propitious; or, after the battle was over to give them thanks. Some choose to derive the word from *hostio*, q. d. *ferio*, "I strike." Isidore on this word remarks, that the name *hostia* was given to those sacrifices which they offered before they marched to attack an enemy, (*antequam ad hostem pergerent*): in contradistinction from *victima*, which were properly those offered after the victory.

Hostia also signified the lesser sorts of sacrifice, and *victima* the larger. A. Gellius says, that every priest, indifferently, might sacrifice the *hostia*, but that the *victima* could be offered by none but the conqueror himself. But, after all, we find these two words promiscuously used one for the other by ancient writers. We read of many kinds of *hostia*: as *hostia pura*, which were pigs or lambs ten days old; *hostia praecedanea*, sacrifices offered the day before a solemn feast; *hostia bidentes*, sacrifices of sheep or other animals of two years old; *hostia esimia*, a sacrifice of the flower of the flock; *hostia succedanea*, sacrifices offered after others which had exhibited some ill omen; *hostia ambarvales*, victims sacrificed after having been solemnly led round the fields at the *ambarvalia*; *hostia amburbiales*, victims slain after the *amburbium*; *hostia cancares* or *caviars*, victims sacrificed every fifth year by the college of pontiffs, in which they offered the part of the tail called *caviar*; *hostia prodigia*, sacrifices in which the fire consumed all, and left nothing for the priests; *hostia piaculares*, expiatory sacrifices; *hostia ambegna* or *ambegna*, sacrifices of cows or sheep that had brought forth twins; *hostia haruges*, victims offered to predict future events from; *hostia mediales*, black victims offered at noon.

HOSTILITY, the action of an enemy, or a state of warfare. The word is Latin, *hostilitas*, formed of the primitive *hostis*, which signifies "enemy;" and which anciently signified "stranger," *hospes*.

HOT-BEDS, in *Gardening*, beds made with fresh horse-dung, or tanners bark, and covered with glasses to defend them from cold winds.

By the skilful management of hot-beds, we may imitate the temperature of warmer climates; by which means, the seeds of plants brought from any of the countries within the torrid zone may be made to flourish even under the poles.

The hot-beds commonly used in kitchen-gardens are made with new horse-dung mixed with the litter of a stable, and a few sea-coal ashes, which last are of service in continuing the heat of the dung. This should remain six or seven days in a heap; and being then turned over, and the parts mixed well together, it should be again cast into a heap; where it may continue five or six days longer, by which time it will have acquired a due heat. These hot-beds are made in the following manner: In some sheltered part of the garden, dig out a trench of a length and width proportionable to the frames you intend it for; and if the ground be dry, about a foot or a foot and a half

deep; but if it be wet, not above six inches: then wheel the dung into the opening, observing to stir every part of it with a fork, and to lay it exactly even and smooth on every part of the bed, laying the bottom part of the heap, which is commonly free from litter, upon the surface of the bed: and if it be designed for a bed to plant out cucumbers to remain for good, you must make a hole in the middle of the place designed for each light about ten inches over, and six deep, which should be filled with good fresh earth, thrusting in a stick to show the places where the holes are; then cover the bed all over with the earth that was taken out of the trench about four inches thick, and put on the frame, letting it remain till the earth be warm, which commonly happens in three or four days after the bed is made, and then the plants may be placed in it. But if your hot-bed be designed for other plants, there need be no holes made in the dung; but after having smoothed the surface with a spade, you should cover the dung about three or four inches thick with good earth, putting on the frames and glasses as before. In making these beds, care must be taken to settle the dung close with a fork; and if it be pretty full of long litter, it should be trod down equally on every part. During the first week or ten days after the bed is made, you should cover the glasses but slightly in the night, and in the day-time carefully raise them, to let out the steam: but as the heat abates, the covering should be increased; and as the bed grows cold, new hot dung should be added round the sides of it.

The hot-bed made with tanners bark is, however, much preferable to that described above, especially for all tender exotic plants and fruits, which require an even degree of warmth to be continued for several months, which cannot be effected with horse-dung. The manner of making them is as follows: Dig a trench about three feet deep, if the ground be dry; but if wet, it must not be above a foot deep at most, and must be raised two feet above the ground. The length must be proportioned to the frames intended to cover it; but it should never be less than ten or twelve feet, and the width not less than six. The trench should be bricked up round the sides to the above-mentioned height of three feet, and filled in the spring with fresh tanners bark that has been lately drawn out of their vats, and has lain in a round heap, for the moisture to drain out of it, only three or four days: as it is put in, gently beat it down equally with a dung-fork; but it must not be trodden, which would prevent its heating, by settling it too close: then put on the frame, covering it with glasses; and in about ten days or a fortnight it will begin to heat; at which time plunge your pots of plants or seeds into it, observing not to tread down the bark in doing it. These beds will continue three or four months in a good temper of heat; and if you stir up the bark pretty deep, and mix a load or two of fresh bark with the old when you find the warmth decline, you will preserve its heat two or three months longer. Many lay some hot horse-dung in the bottom of the trench under the bark; but this ought never to be practised unless the bed is wanted sooner than the bark would heat of itself, and even then there ought only to be a small quantity of dung at the bottom.

Hot-beds.

The

^{ot-house} ^{||} ^{atentots} The frames which cover these beds should be proportioned to the several plants they are designed to contain. If they are to cover the ananas or pineapple, the back part should be three feet high, and the lower part 14 inches: if the bed be intended for taller plants, the frame must be made of a depth proportionable to them; but if it be for sowing of seeds, the frame need not be above 14 inches high at the back, and 7 in the front; by which means the heat will be much greater.

Hot-House. See *STOVE* and *HYPOCAUSTUM*.

HOTEL, a French term, anciently signifying a house or dwelling place.—It is now more commonly used for the palaces or houses of the king, princes, and great lords. In this sense they say, the *hotel de Conde*, *hotel de Conti*, *hotel du Louvre*, &c.

The grand *prevot de l'hotel*, is the first judge of the officers of the king's household. His jurisdiction is much like that of lord steward of the household of the king of England.

The *hotel de ville* is what we call a *town-house* or *town-hall*.

HOTEL, is likewise used for a large inn, also for a large lodging-house ready furnished.

HOTTENTOTS, a people in the southern part of Africa, whose country extends north by west from the Cape of Good Hope beyond the mouth of Orange river, and from that cape in an east-north-east direction to the mouth of the great Fish river, which parts it from Caffraria. According to Sanutus, this coast, beginning at the Mountains of the Moon under the tropic of Capricorn in $23\frac{1}{2}^{\circ}$ S. Lat. extends north beyond the Cape to the coast of Zanguebar; having the Indian sea on the east, the Ethiopic on the west, the southern ocean on the south; and on the north the kingdoms of Mattatan, Monomotapa, and the coast of Zanguebar, or rather the Mountains of the Moon, which divide it from the rest of the continent.

The Europeans first became acquainted with this country in the year 1493, when Bartholomew Diaz, a Portuguese admiral, discovered the most southerly point of Africa, now called the *Cape of Good Hope*, but by him *Cabos dos totos tormentos*, or Cape of all Plagues, on account of the storms he met with in the neighbourhood; but John, then king of Portugal, having from the account of Diaz concluded that a passage to the East Indies was now discovered, changed the name to that of the *Cape of Good Hope*, which it still retains. In 1497, it was circumnavigated by Vasco de Gama, who made a voyage to India that way; however, it remained useless to Europeans till the year 1650, when Van Riebeck a Dutch surgeon first saw the advantages that would accrue to the East India company in Holland from a settlement at such a convenient distance both from home and from India. The colony which he planted has ever since continued in the hands of the Dutch, has greatly increased in value, and is visited by all the European ships trading to the East Indies. See *GOOD-HOPE*.

The country now possessed by the Dutch is of pretty considerable extent, and comprehends that part of the African coast on the west called *Terra de Natal*. It is naturally barren and mountainous; but the industry of the Dutch hath overcome all natural difficul-

ties, and it now produces not only a sufficiency of all the necessaries of life for the inhabitants, but also for the refreshment of all the Europeans who pass and re-^{Hottentots} pass that way.

The coast abounds in capes, bays, and roads. Thirty leagues to the east of the Cape of Good Hope, in S. Lat. $34. 21.$ is another cape which runs out beyond 35° , called by the Portuguese, who first doubled it, *Cabo dos Agulhas*, or the *Cape of Needles*, on account of some strange variations in the magnetical needle observed as they came near it. Near this cape is a flat shore, with plenty of fish: it begins in the west near a fresh-water river, and, extending 15 leagues in the main sea, ends in the east near *Fish-bay*. Cabo Falso, so called by the Portuguese, who returning from India mistook it for the Cape of Good Hope, lies to the eastward between these two capes, about eight or nine leagues beyond that of Good Hope. Along the coasts, on both sides of the Cape of Good Hope, are many fine bays. Twenty-seven leagues to the north-west is Saldanha bay, so named from a Portuguese captain shipwrecked on the coast. The largest and most commodious is *Table Bay*, on the south, and near the mountain of that name, six leagues in circumference, with four fathoms water close to the beach. Opposite to this bay is *Robu Eilan*, or the island of Rabbits in $34. 30.$ S. Lat. 67 leagues east from the Cape of Good Hope. Peter Both, in 1661, discovered a bay, which he named *Uleest*, sheltered only from north winds, in which is a small island, and on the west a rivulet of fresh water extremely convenient for European mariners. Twenty-five or thirty leagues farther east Both discovered Marshal Bay, afterwards named by the Portuguese *Seno Formoso*. Next to this is *Seno de Lago*, from its resemblance to a lake. There are several roads in this bay, and an island called *Ilha dos Coos*. Cabo de S. Francisco, and Cabo das Serras, are marked upon charts between these two bays. Near the latter of these capes is Cabo de Arecito, and the island Contento; and something more north-east is St Christopher's river, called *San Christovano* by the Portuguese, and by the Hottentots *Nagod*. The country beyond this river was called by the Portuguese, who discovered it on the day of our Lord's nativity, *Terra de Natal*. Between the Cape of Good Hope and Cabo das Agulhas are the Sweet, Salt, and Jagulina rivers, which run into the sea, and Sweet-water river flows from the Table-mountain.

The most remarkable mountains in this country are, Table-mountain, Devil's Tower, Lion's Head, and the Tiger hills. The three first lie near Table-bay, and surround Table-valley, where the Cape-town stands. (See the article *GOOD-HOPE*). Mr Forster, in his voyage, informs us, that "the extremity of Africa towards the south is a mass of high mountains, of which the outermost are craggy, black, and barren, consisting of a coarse granite, which contains no heterogeneous parts, such as petrified shells, &c. nor any volcanic productions. The ground gradually rises on all sides towards the three mountains which lie round the bottom of the bay, keeping low and level only near the sea-side, and growing somewhat marshy in the isthmus between False and Table bays, where a salt rivulet falls into the latter. The marshy part has some verdure, but inter-

Hottentots mixed with a great deal of sand. The higher grounds, which, from the sea side, have a parched and dreary appearance, are, however, covered with an immense variety of plants, among which are a prodigious number of shrubs, but scarce one or two species that deserve the name of *trees*. There are also a few small plantations wherever a little run of water moistens the ground. The ascent of Table-mount is very steep and difficult, on account of the number of loose stones which roll away under the feet of the traveller. About the middle of the mountain is a bold, grand chasm, whose walls are perpendicular, and often impending rocks piled up in strata. Some rills of water ooze out of crevices, or fall from precipices in drops, giving life to hundreds of plants and low shrubs in the chasm. The summit of the mountain is nearly level, very barren, and bare of soil; several cavities, however, are filled with rain water, or contain a small quantity of vegetable earth, from whence a few odoriferous plants draw their nourishment. Some antelopes, howling baboons, solitary vultures, and toads, are sometimes to be met with on the mountain. The view from thence is very extensive and picturesque. The bay seems a little pond or bason, and the ships in it dwindled to little boats; the town under our feet, and the regular compartments of its gardens, look like the work of children.

Most accounts of this country that have been published mention a surprising phenomenon which is annually to be seen on the top of Table-hill from September to March; namely, a white cloud hovering on its top, and called by sailors *the Devil's table-cloth*. (See the article *Good-Hope*). This cloud is said by some to appear at first no bigger than a barley-corn; then increases to the size of a walnut, and soon after covers the whole top of the mount. But, according to Mr Kolben, it is never less, even on its first appearance, than the size of a large ox, often bigger. It hangs in several fleeces over the Table-hill and the Wind or Devil's-hill; which fleeces, at last uniting, form a large cloud that covers the summits of these two hills. After this has rested for some time without change or motion, the wind bursts out suddenly from it with the utmost fury. The skirts of the cloud are white, but seem much more compact than the matter of common clouds; the upper parts are of a leaden colour. No rain falls from it, but sometimes it discovers a great deal of humidity; at which times it is of a darker colour, and the wind issuing from it is broken, raging by fits of short continuance. In its usual state, the wind keeps up its first fury unabated for one, two, three, or eight days; and sometimes for a whole month together. The cloud seems all the while undiminished, though little fleeces are from time to time detached, from it, and hurried down the sides of the hills, vanishing when they reach the bottom, so that during the storm the cloud seems to be supplied with new matter. When the cloud begins to brighten up, these supplies fail, and the wind proportionably abates. At length, the cloud growing transparent, the wind ceases. During the continuance of these south-east winds, the Table-valley is torn by furious whirlwinds. If they blow warm, they are generally of short duration; and in this case the cloud soon disappears. This wind rarely blows till after sunset, and never longer than till

towards midnight, though the cloud remains; but then it is thin and clear: but when the wind blows cold, it is a sure sign, that it will last for some time, an hour at noon and midnight excepted; when it seems to lie still to recover itself, and then lets loose its fury anew.

The Europeans at the Cape consider the year as divided into two seasons, which they term *monsoons*; the wet monsoon or winter, and the dry one or summer. The first begins with our spring in March; the latter with September, when our summer ends. In the summer monsoon reign the south-east winds already mentioned; which though they clear and render the air more healthy, yet make it difficult for ships outward bound to enter Table-bay. In the bad season, the Cape is much subject to fogs; and the north-west winds and rain make the inhabitants stay much at home. But there are frequent intermissions and many clear days till June and July; when it rains almost continually, and from thence till summer. The weather in winter is cold, raw and unpleasant; but never more rigorous than autumn in Germany. Water never freezes to above the thickness of half a crown; and as soon as the sun appears the ice is dissolved. The Cape is rarely visited with thunder and lightning, excepting a little near the turn of the seasons, which never does any hurt. During the continuance of the south-east winds which rage in summer, the sky is free of all clouds except that on the Table and Wind Hills, already mentioned; but during the north-west winds, the air is thick, and loaded with heavy clouds big with rain. If the south-east winds should cease for any length of time, the air becomes sickly by reason of the sea weeds driving ashore and rotting; hence the Europeans are at such times affected with headachs and other disorders: but, on the other hand, the violence of those winds subjects them to inflammation of their eyes, &c.

The natives of this country are called *Hottentots*, in their own language; a word of which it is vain to inquire the meaning, since the language of this country can scarce be learned by any other nation. The *Hottentot* language is indeed said to be a composition of the most strange and disagreeable sounds, deemed by many the disgrace of speech, without human sound or articulation, resembling rather the noise of irritated turkeys, the chattering of magpies, hooting of owls, and depending on extraordinary vibrations, inflections, and clashings of the tongue against the palate.—If this account is true, however, it is obvious, that all the relations we have concerning the religion, &c. of the *Hottentots* derived from themselves, must fall to the ground, as nobody can pretend to understand a language in itself unintelligible. The manners and customs of those people, however, are easily observable, whether they themselves give the relation or not; and if their language is conformable to them, it is no doubt of a nature sufficiently wonderful.

Many accounts have been published concerning the extreme nastiness and filthy customs of the *Hottentots*; but from the observations of late travellers it appears, that these have either been exaggerated, or that the *Hottentots* (which is not improbable) have in some measure laid aside their former manners. Dr Sparrman describes them in much less disgusting terms, and M.

Vaillant

Hottentots. Vaillant seems to have been charmed with their innocence and simplicity. According to the doctor, these people are as tall as the generality of Europeans, though more slender in their persons, which he attributes to their scanty supply of food, and not accustoming themselves to hard labour. The characteristic of the nation, however, and which he thinks has not been observed by any one before, is, that they have small hands and feet in proportion to the other parts of their body. The distance between the eyes appears greater than in Europeans, by reason of the root of the nose being very low. The tip is pretty flat, and the iris of the eye has generally a dark-brown cast, sometimes approaching to black. Their skin is of a yellowish brown, something like that of an European who has the jaundice in a high degree; though this colour does not in the least appear in the whites of the eyes. Their lips are thinner than those of their neighbours the *Negroes*, *Caffres*, or *Mozambiques*. "In fine (says our author), their mouths are of a middling size, and almost always furnished with a set of the finest teeth that can be seen; and, taken together with the rest of their features, as well as their carriage, shape, and every motion, in short their *tout ensemble* indicates health and delight, or at least an air of *sans souci*. This careless mien, however, discovers marks at the same time both of alacrity and resolution; qualities which the Hottentots, in fact, can show upon occasion." The hair of the head is black and frizzled; though not very close; and has so much the appearance of wool, that it would be taken for it, were it not for its harshness. They have but seldom any appearance of a beard, or hair upon other parts of their bodies; and when any thing of this kind happens to be visible, it is always very slight.

A general opinion has prevailed, that the Hottentot women have a kind of natural veil which covers the sexual parts; but this is denied by our author. "The women (says he) have no parts uncommon to the rest of their sex: but the clitoris and nymphæ, particularly of those who are past their youth, are pretty much elongated; a peculiarity which has undoubtedly got footing in this nation in consequence of the relaxation necessarily produced by the method they have of besmearing their bodies, their slothfulness, and the warmth of the climate."

The Hottentots besmear all their bodies copiously with fat mixed up with a little soot. "This (says our author) is never wiped off; on the contrary, I never saw them use any thing to clean their skins, excepting that when in greasing the wheels of their waggons their hands were besmeared with tar and pitch, they used to get it off very easily with cow-dung, at the same time rubbing their arms into the bargain up to the shoulders with this cosmetic; so that as the dust and other filth, together with their sooty ointment, and the sweat of their bodies, must necessarily, notwithstanding it is continually wearing off, in some measure adhere to the skin, it contributes not a little to conceal the natural hue of the latter, and at the same time to change it from a bright amber-brown to a brownish yellow colour, obscured with filth and nastiness."—The doctor was enabled to discover the natural colour of the Hottentots by means of the nicety of some Dutch farmers' wives, who had made their Hottentot girls wash and scour their skins, that they

VOL. X. Part II.

might be less filthy in looking after the children, or **Hottentots.** doing any other work that required cleanliness. Many of the colonists, however, are of opinion, that this operation of washing is no improvement to the look of a Hottentot; but that their natural yellow is fully as disagreeable as the black or brown colour of the ointment; and that the washed skin of a native of this country seems to be deficient in dress, like shoes that want blacking. This the doctor does not pretend to determine; though, whatever may be supposed deficient in look, we should think must be made up in cleanliness.

The Hottentots perfume their bodies, by daubing them all over with the powder of an herb, the smell of which is at once rank and aromatic, approaching to that of the poppy mixed with spices. For this purpose they use various species of the diosma, called by them *bucku*, and which they imagine to be very efficacious in the cure of disorder. One species of this plant, growing about *Goud's river*, is said to be so valuable, that no more than a thimble-full of its powder is given in exchange for a lamb.

By the ointment of soot and grease stuck full of the powder of *bucku*, a paste is formed which defends the bodies of the Hottentots in a great measure from the action of the air; so that they require very few clothes, and in fact go almost quite naked. The only covering of the men consists of two leather straps, which generally hang down the back from the chine to the thighs, each of them in the form of an isosceles triangle, their points uppermost, and fastened to a belt which goes round their waist, their bases not being above three fingers broad; so that the covering they form is extremely trifling. These straps have very little dressing bestowed upon them, so that they make a rattling noise as the Hottentot runs along; and our author supposes that they may produce an agreeable coolness by fanning him. Besides this, the men have a bag or flap made of skin which hangs down before, and is fastened to the belt already mentioned. The hollow part of this seems designed to receive that which with us modesty requires to be concealed; but being only fastened by a small part of its upper end to a narrow belt, in other respects hanging quite loose, it is but a very imperfect concealment; and when the wearer is walking, or otherwise in motion, it is none at all. They call this purse by the Dutch name of *jackall*, it being almost always prepared of the skin of that animal, with the hairy side turned outwards.

The women cover themselves much more scrupulously than the men, having always two, and very often three coverings like aprons; though even these seem to be abundantly small for what we would term decency in this country. The outermost of these, which is the largest, measures only from about six inches to a foot in breadth. All of them are made of a skin well prepared and greased, the outermost being adorned with glass beads strung in different figures. The outermost reaches about half-way down the thighs, the middle about a third or one half less, and the third scarcely exceeds the breadth of the hand. The first is said to be designed for ornament, the second as a defence for modesty, and the third to be useful on certain occasions, which, however, are much less troublesome to the Hottentot than to the European females. Our author,

4 L

Hottentot. with great probability, supposes that it was the sight of this innermost apron which misled the reverend Jesuit Tackard, who, on his return to Europe, first propagated the stories concerning the natural veils or excrescences of the Hottentots.—A story was likewise commonly believed, that the men in general had but one testicle, and that such as were not naturally formed in this manner were artificially made so. But this our author likewise denies; and though he says that such an operation might have been formerly performed upon the males, yet it is not so now.

The other garments worn by the Hottentots are formed of a sheep's skin with the woolly side turned inwards; thus forming a kind of cloak, which is tied forwards over the breast: though sometimes, instead of a sheep's skin, some smaller kind of fur is used as a material. In warm weather they let this cloak hang carelessly over their shoulders, so that it reaches down to the calves of the legs, leaving the lower part of the breast, stomach, and fore part of the legs and thighs bare; but in cold weather they wrap it round them; so that the fore part of the body is likewise pretty well covered by it as far as the knees: But as one sheep-skin is not sufficient for this purpose, they sew on a piece on the top at each side with a thong or catgut. In warm weather they sometimes wear the woolly side outwards, but more frequently take off the cloak altogether, and carry it under their arm. This cloak or *krosse* serves them not only for clothes, but bedding also; and in this they lie on the bare ground, drawing up their bodies so close, that the cloak is abundantly sufficient to cover them.—The cloaks used by the women differ little from those already described, excepting only that they have a long peak on them, which they turn up; forming with it a little hood or pouch, with the hairy side inwards. In this they carry their little children, to which the mother's breasts are now and then thrown over the shoulders; a custom common among some other nations, where the breasts of the females, by continual want of support, grow to an enormous length. The men commonly wear no covering on their heads, though our author says he has seen one or two who wore a greasy night-cap made of skin with the hair taken off. Those who live nearest the colonists have taken a liking to the European hats, and wear them slouched all round, or with only one side turned up. The women also frequently go bare-headed; though they sometimes wear a cap made in the shape of a short truncated cone. This appears to be the section of some animal's stomach, and is perfectly blacked by soot and fat mixed up together. These caps are frequently prepared in such a manner as to look shaggy; others have the appearance of velvet; and in our author's apprehension are not inelegant. Over this they sometimes wear an oval wreath or kind of crown made of a buffalo's hide, with the hair outermost. It is about four fingers breadth in height, and surrounds the head so as to go a little way down upon the forehead, and the same depth on the neck behind, without covering the upper part of the cap above described. The edges of this wreath, both upper and under, are always smooth and even; each of them set with a row of small shells of the *cyprea* kind, to the number of more than 30, in such a manner, that, being placed quite close to one another, their beautiful white

enamel, together with their mouths, are turned outwards. Between two rows of these shells run two others parallel, or else waved and indented in various ways. The Hottentots never adorn their ears or noses as other savages do: though the latter are sometimes marked with a black streak of soot; at others, though more rarely, with a large spot of red lead; of which last, on festivals and holidays, they likewise put a little on their cheeks. The necks of the men are bare, but those of the women are ornamented with a thong of undressed leather, upon which are strung eight or ten shells. These, which are about the size of beans, have a white ground, with large black spots of different sizes: but as they are always made use of in a bur-nished state, the doctor is uncertain whether they be of that kind which is described in the *Systema Naturæ* under the name of *nerita albicilla*, or *exuvia*. These shells are sold at an enormous price, no less than a sheep for each; as it is said that they come from the more distant coast of Caffraria. Both men and women are very fond of European beads, particularly the blue and white ones of the size of a pea; of which they tie several rows round the middle, and next to the girdles which hold the coverings above mentioned. Besides these ornaments, they use rings on their arms and legs, most of them made of thick leather straps generally cut in a circular shape; which, by being beat and held over the fire, are rendered tough enough to retain the curvature that is given them. From these rings it has been almost universally believed, that the Hottentots wrap guts about their legs in order to eat them occasionally. The men wear from one to five or six of these rings on their arms, just above the wrist, but seldom on their legs. The matrons of a higher rank have frequently a considerable number of them both on their arms and legs, especially on the latter: so that they are covered with them from the feet up to the knees. These rings are of various thicknesses, from that of a goose-quill to two or three times that size. Sometimes they are made of pieces of leather forming one entire ring; so that the arms and feet must be put through them when the wearer wishes to put them on. They are strung upon the legs, small and great, without any nicety; but are so large, that they shake and get twisted when the person walks. Rings of iron or copper, but especially of brass, of the size of a goose-quill, are considered as more genteel than those of leather. However, they are sometimes worn along with the latter, to the number of six or eight at a time, particularly on the arms. The girls are not allowed to use any rings till they are marriageable. The Hottentots seldom wear any shoes; but such as they do make use of are of the same form with those worn by the African peasants, by the Esthoniains, and Livonians, as well as by some Finlanders; so that it is impossible to say whether they are the invention of the Dutch or the Hottentots themselves. They are made of undressed leather, with the hairy side outward; without any other preparation than that of being beat and moistened. If it be a thick and stout hide, as that of a buffalo, it is kept for some hours in cow-dung, which renders it besides very soft and pliable. Some kind of grease is afterwards used for the same purpose. The shoes are then made in the following manner. They take a piece of leather of a rectangular

Hottentots. lar form, something longer and broader than the foot of the person for whom the shoes are intended; the two foremost corners are doubled up together, and sewed down, so as to cover the fore-part of the foot; but this seam may be avoided, and the shoes made much neater at the toes, by fitting immediately over them a cap taken from the membrane in the knee-joint of the hind-leg of some animal. In order to make this piece of skin or leather rise up to the height of an inch on both sides of the foot, and close it in neatly, it is pierced with holes at small distances all round the edge, as far as the hind-quarters; and through these holes is passed a thong, by which the rim is drawn up into gathers. In order to make strong hind-quarters, the back part of the piece of leather is doubled inwards, and then raised up and pressed along the heel. The ends of the thong or gathering string are then threaded on both sides through the upper edge of the hind-quarters, to the height of about two inches; they are then carried forwards in order to be drawn through two of the above-mentioned holes on the inside of each rim. Lastly, They are tied over the instep, or if it be thought necessary to tie the shoe still faster, they are carried crosswise over the instep, and so downwards under the thong, which comes out from the hind quarters; then upwards again over the ankle, and even round the leg itself if the wearer chooses. Shoes of this kind are not without their advantages: they sit as neat upon the foot as a stocking, and at the same time preserve their form. They are easily kept soft and pliable by constantly wearing them; or if at any time they should become somewhat hard, this is easily remedied by beating and greasing them. They are extremely light and cool, by reason that they do not cover so much of the foot as a common shoe. They wear very well, as they are without any seam, and the soles of the shoes are both tough and yielding. These field shoes, as they are called, being made of almost raw leather, are much more durable than those of tanned leather, which are burnt up by the African sands, and slip and roll about in them; being also very ready to be torn in a rocky soil, which is not the case with the others. The doctor is of opinion, that these shoes would be particularly useful to sailors.

The huts of the Hottentots are built exactly alike; and we may readily give credit to our author when he tells us, that they are done in a style of architecture which does not a little contribute to keep envy from insinuating itself under the roofs. Some of these huts are circular, and others of an oblong shape, resembling a round bee-hive or vault; the ground-plot being from 18 to 24 feet in diameter. The highest are so low, that it is scarce ever possible for a middle-sized man to stand upright even in the centre of the arch; "but (says our author) neither the lowness thereof, nor that of the door, which is but just three feet high, can perhaps be considered as any inconvenience to an Hottentot, who finds no difficulty in stooping and crawling upon all fours, and is at any time more inclined to lie down than to stand. The fire-place is in the middle of each hut, by which means the walls are not so much exposed to danger from fire. From this situation of the fire-place also the Hottentots derive this additional advantage, that they can all sit or lie in a circle round it, enjoying equally the warmth of the

fire. The door, low as it is, alone lets in day-light or lets out the smoke: and so much are these people accustomed to live in such smoky mansions, that their eyes are never affected by it in the least, nor even by the mephitic vapour of the fuel, which to Europeans would be certain death.

The frame of the arched roof is composed of slender rods or sprays of trees. These being previously bent into a proper form, are laid, either whole or pieced, some parallel to one another, others crosswise; after which they are strengthened by binding others round them in a circular form with withies. All these are taken principally from the *cliffortia conoides*, which grows plentifully in this country near the rivers. Large mats are then placed very neatly over this lattice work, so as perfectly to cover the whole. The aperture which is left for the door is closed occasionally by a skin or piece of matting. These mats are made of a kind of cane or reed in the following manner. The reeds being laid parallel to one another, are fastened together with sinews or catgut, or some kind of catgut which they have had an opportunity of getting from the Europeans; so that they have it in their power to make them as long as they please, and as broad as the length of the reeds, which is from six to ten feet. The colonists make use of the same kind of matting, next to the tilts of their waggons, to prevent the sail-cloth from being rubbed and worn, and likewise to help to keep out the rain.

In a *kraal*, or Hottentot village, the huts are most commonly disposed in a circle with the doors inwards; by which means a kind of court-yard is formed, where the cattle are kept at nights. The milk, as soon as taken from the cow, is put to other milk which is curdled, and kept in a leather sack with the hairy side inwards, as being the more cleanly; so that thus the milk is never drunk sweet. In some northern districts, where the land is dry and parched, both Hottentots and colonists are shepherds. When a Hottentot has a mind to shift his dwelling, he lays all the mats, skins, and rods, of which it is composed, on the backs of his cattle, which, to a stranger, makes a monstrous, unwieldy, and even ridiculous appearance.

There is a species of Hottentots named *Boshiesmen*, who dwell in the woody and mountainous parts, and subsist entirely by plunder. They use poisoned arrows, which they shoot from bows about a yard long and an inch in thickness in the middle, very much pointed at both ends. Dr Sparrman does not know the wood of which they are made, but thinks that it is not very elastic. The strings were made, some of sinews, and others of a kind of hemp, or the inner bark of some vegetable; but most of them in a very slovenly manner. The arrows are about a foot and a half long, headed with bone and a triangular bit of iron; having also a piece of quill bound on very strongly with sinews, about an inch and a half from the top, in order to prevent it from being easily drawn out of the flesh. The whole is lastly covered over with a very deadly poison of the consistence of an extract. Their quivers are two feet long and four inches in diameter; and are supposed by our author to be made of the branch of a tree hollowed out, or more probably of the bark of one of the branches taken off whole, the bottom and cover being made of leather.

Hotentots. It is daubed on the outside with an unctuous substance which grows hard when dry, and is lined about the aperture with the skin of the yellow serpent, supposed to be the most deadly in all that part of the world. The poison they make use of is taken from the most venomous serpents; and, ignorant as the Hotentots are, they all know that the poison of serpents may be swallowed with safety. See the article BOSHIEMEN.

In the year 1779, Lieutenant William Paterson, who took a long and dangerous excursion from the Cape along the western side of the continent, discovered a new tribe of Hotentots, whose living, he says, is in the highest degree wretched, and who are apparently the dirtiest of all the Hotentot tribes. Their dress is composed of the skins of seals and jackals, the flesh of which animals they feed upon. If a grampus happens to be cast ashore, they remove their huts to the place, and feed upon the carcase as long as it lasts, though perhaps it may be half rotten by the heat of the weather. They besmear their skins with the oil; by which means they smell so exceedingly rank that their approach may be thus perceived before they come in sight. Their huts, however, are much superior to those of the southern Hotentots already described; being higher, thatched with grass, and furnished with stools made of the back bones of the grampus. They dry their fish in the sun; as the lieutenant found several kinds of fish near their huts suspended from poles, probably for this purpose. He found also several aromatic plants which they had been drying.

With respect to the religion of the Hotentots, it does not appear that they have any. On being questioned on the subject of a Creator and Governor of the universe, they answer that they know nothing of the matter; nor do they seem willing to receive any instruction. All of them, however, have the most firm belief in the powers of magic; from whence it might be inferred that they believe in an evil being analogous to what we call *the devil*; but they pay no religious worship to him, though from this source they derive all the evil that happens, and among these evils they reckon cold, rain, and thunder. So monstrously ignorant are they, that many of the colonists assured Dr Sparrman, that their Boshiesmen would abuse the thunder with many opprobrious epithets, and threaten to assault the flashes of lightning with old shoes, or any thing that comes first to hand. Even the most intelligent among them could not be convinced by all the arguments our author could use, that rain was not always an evil, and that it would be an unhappy circumstance if it were never to rain. "A maxim (says he), from a race of men in other respects really endowed with some sense, and frequently with no small degree of penetration and cunning, ought, methinks to be considered as an indelible religious or superstitious notion entertained by them from their infancy, rather than as an idea taken up on due deliberation and consequent conviction."

As the Hotentots have so strong a belief in the powers of magic, it is no wonder that they have abundance of witches and conjurers among them. These will readily undertake any thing, even to put a stop to thunder and rain, provided they be well paid for their pains; and if it happen to thunder or rain longer than the time they promised, they have always for an

excuse, that a more powerful conjurer has put a stop Hotentot to their incantations. Many of the Hotentots believe that all disorders incident to the human body are cured by magic. The wizards are fond of encouraging this idea: but at the same time take care to employ both external and internal remedies. Among the former may be reckoned a cure performed upon Captain Cook in some of the South-sea islands, viz. that of pinching, cuffing, and kneading the whole body of the patient. To this, however, the Hotentot physicians add that of pretending to suck out a bone from some part of the patient's body. After this it sometimes happens that the sick person is relieved, and sometimes not. In the latter case the operation is repeated; and if he dies, his friends lament that he was bewitched beyond the power of any one to assist him. These conjurers appear to be possessed of considerable slight of hand. Our author was informed by a colonist, that when he was a child, and playing with a bone of an ox which he drew as a cart, it appeared to his great astonishment to be sucked out of a sick person's back by a wizard; and as far as he could remember, the patient recovered soon after. These pretensions of the wizards sometimes render them liable to persecutions; and there is an instance of a chief named *Paloo*, who ordered a general massacre among them, in hopes of cutting off the person who he believed had bewitched himself, and afflicted him with sore eyes.

The superstition of the Hotentots never operates in the way of making them afraid in the dark. They seem, however, to have some ideas of a future state, as they reproach their friends, when dead, with leaving them so soon: at the same time admonishing them from henceforth to demean themselves properly; by which they mean, that their deceased friends should not come back again and haunt them, nor allow themselves to be made use of by wizards to bring any mischief on those that survive them.

There is a genus of insects (the *mantis*) which, it has been generally thought, the Hotentots worship; but our author is so far from being of this opinion, that he tells us they have more than once caught several of them for him, and assisted him in sticking pins through them as he did through other insects. "There is (says he), however, a diminutive species of this insect, which some think it would be a crime, as well as very dangerous to do any harm to: but this we have no more reason to look upon as any kind of religious worship, than we have to consider in the same light a certain superstitious notion prevalent among many of the more simple people in our own country (Sweden), who imagine that their sins will be forgiven them, if they set a cock-chaser on its feet that has happened to fall upon its back. The moon, according to Kolbe, receives a kind of adoration from the Hotentots; but the fact is, that they merely take the opportunity of her beams, and at the same time of the coolness of the night, to amuse themselves with dancing, and consequently have no more thoughts of worshipping her than the Christian colonists who are seen at that time strolling in great numbers about the streets, and parading on the stone steps with which their houses are usually encircled. The conjurers themselves, according to our author, are generally freethinkers, who have neither religion nor superstition of any kind.

Lieutenant

Hottentots. Lieutenant Paterson has given the following account of the Caffres, a nation whom no Europeans but himself had then seen, and who inhabit the country to the north-east of the Cape as far down as 31° south latitude.

The men are from five feet ten inches to six feet high, and well proportioned; and in general manifest great courage in attacking lions or other wild beasts. The nation, at the time he visited them, was divided into two parties, one to the northward, commanded by a chief named *Cha Cha Bea*, or *Tambushie*, which latter appellation he had obtained from his mother, a woman of an Hottentot tribe named *Tambukies*. This man was the son of a chief named *Pharoa*, who died about three years before, and left two sons *Cha Cha Bea*, and another named *Dsirika*, who claimed the supreme authority on account of his mother being of the Caffre nation. This occasioned a contest between the two brothers, in the course of which *Cha Cha Bea* was driven out of his territories with a great number of his party; after which he took up his residence at a place named *Khouta*, where he had an opportunity of entering into an alliance with the Boshiesmen.—The Caffres are of a jet black colour, their eyes large, and their teeth as white as ivory. The clothing of both sexes is nearly the same; consisting entirely of the hides of oxen, which are made as pliant as cloth. The men wear tails of different animals tied round their thighs, pieces of brass in their hair, and large rings of ivory on their arms: they are likewise adorned with the hair of lions, feathers fastened on their heads, &c. They use the ceremony of circumcision, which is usually performed upon them when they are nine years of age. They are very fond of dogs, which they exchange for cattle, and will even give two bullocks in exchange for one dog which pleases them. They are expert in throwing lances, and in time of war use shields made of the hides of oxen. Throughout the day the men occupy themselves in hunting, fighting, or dancing; the women being employed in the cultivation of their gardens and corn. They seem not to be destitute of the knowledge of agriculture, as they cultivate several vegetables which do not naturally grow in their own country, viz. tobacco, water-melons, a small kind of kidney-beans, and hemp. The women also make their baskets, and the mats on which they lie. The men are very fond of their cattle, and cut their horns in such a manner as to be able to turn them into any shape they please, and teach them to answer to a whistle. Mr Paterson is of opinion, that the country they inhabit is greatly superior to any part of Africa.

Of the Dutch settlements and policy at the Cape, Mr Forster gives the following account.

“The income of the governor here is very considerable: for, besides a fixed appointment, and the use of houses, gardens, proper furniture, and every thing that belongs to his table, he receives about 10 dollars for every leagre of wine which the company buy of the farmer in order to be exported to Batavia. The company allows the sum of 40 dollars for each leagre, of which the farmer receives but 24: what remains is shared between the governor and second or deputy; the former taking two-thirds, which sometimes are said to amount to 4000 dollars per annum.

The Deputy-governor has the direction of the company's whole commerce here, and signs all orders to the different departments under him, as well as the governor to others. He and the fiscal have the rank of *upper koopman*. The fiscal is at the head of the police, and sees the penal laws put in execution: his income consists of fines, and of the duties laid on certain articles of commerce; but if he be strict in exacting them, he is universally detested. The sound policy of the Dutch has likewise found it necessary to place the fiscal as a check, to overawe the other officers of the company, that they may not counteract the interests of their masters, or infringe the laws of the mother-country. He is, to that end, commonly well versed in juridical affairs, and depends solely upon the mother-country. The major (at present Mr Von Prehn, who received us with great politeness) has the rank of *koopman* or merchant: this circumstance surprises a stranger, who, in all other European states, is used to see military honours confer distinction and precedence; and appears still more singular to one who knows the contrast in this particular between Holland and Russia, where the idea of military rank is annexed to every place, even that of a professor at the university. The number of regular soldiers at this colony amounts to about 700, of which 400 form the garrison of the fort, near the Cape-town. The inhabitants capable of bearing arms form a militia of 4000 men, of whom a considerable part may be assembled in a few hours, by means of signals made from alarm-places in different parts of the country. We may from hence make some estimate of the number of white people in this colony, which is at present so extensive, that the distant settlements are above a month's journey from the Cape: but these remote parts lie sometimes more than a day's journey from each other, are surrounded by various nations of Hottentots, and too frequently feel the want of protection from their own government at that distance. The slaves in this colony are at least in the proportion of five or more to one white person. The principal inhabitants at the Cape have sometimes from 20 to 30 slaves, who are in general treated with great lenity, and sometimes become great favourites with their masters, who give them very good clothing, but oblige them to wear neither shoes nor stockings, reserving these articles to themselves. The slaves are chiefly brought from Madagascar, and a little vessel annually goes from the Cape thither on that trade; there are, however, besides them, a number of Malays and Bengulese, and some negroes. The colonists themselves are for the greatest part Germans, with some families of Dutch and some of French Protestants. The character of the inhabitants of the town is mixed. They are industrious, but fond of good living, hospitable, and social, though accustomed to hire their apartments to strangers for the time they touch at this settlement, and used to be complimented with rich presents of stoffs, &c. by the officers of merchant ships. They have no great opportunities of acquiring knowledge, there being no public schools of note at the Cape; their young men are therefore commonly sent to Holland for improvement, and their female education is too much neglected. A kind of dislike to reading, and the want of public amusements, make their conversation uninteresting, and too frequently turn it upon scandal,

Hottentots. scandal, which is commonly carried to a degree of inveteracy peculiar to little towns. The French, English, Portuguese, and Malay languages, are very commonly spoken, and many of the ladies have acquired them. This circumstance, together with the accomplishments of singing, dancing, and playing a tune on the lute, frequently united in an agreeable person, make amends for the want of refined manners and delicacy of sentiment. There are, however, among the principal inhabitants, persons of both sexes, whose whole deportment, extensive reading, and well-cultivated understanding, would be admired and distinguished even in Europe. Their circumstances are in general easy, and very often affluent, on account of the cheap rate at which the necessaries of life are to be procured: but they seldom amass such prodigious riches here as at Batavia; and I was told the greatest private fortune at the Cape did not exceed 100,000 dollars, or about 25,000l. sterling.

“The farmers in the country are very plain hospitable people; but those who dwell in the remotest settlements seldom come to town, and are said to be very ignorant. This may easily be conceived, because they have no better company than Hottentots, their dwellings being often several days journey asunder, which must in a great measure preclude all intercourse. The vine is cultivated in plantations within the compass of a few days journey from the town; which were established by the first colonists, and of which the ground was given in perpetual property to them and their heirs. The company at present never part with the property of the ground, but let the surface to the farmer for an annual rent, which, though extremely moderate, being only 25 dollars for 60 acres, yet does not give sufficient encouragement to plant vineyards. The distant settlements, therefore, chiefly raise corn and rear cattle; nay, many of the settlers entirely follow the latter branch of rustic employment, and some have very numerous flocks. We were told there were two farmers who had each 15,000 sheep, and oxen in proportion; and several who possessed 6000 or 8000 sheep, of which they drive great droves to town every year; but lions and buffaloes, and the fatigue of the journey, destroy numbers of their cattle before they can bring them so far. They commonly take their families with them in large waggons covered with linen or leather, spread over hoops, and drawn by 8, 10, and sometimes 12 pair of oxen. They bring butter, mutton-tallow, the flesh and skins of river-horses (hippopotamus), together with lion and rhinoceros skins, to sell. They have several slaves, and commonly engage in their service several Hottentots of the poorer sort, and (as we are told) of the tribe called **BOSHIESMEN**, *Boschemans*, or *Bushmen*, who have no cattle of their own, but commonly subsist by hunting, or by committing depredations on their neighbours. The opulent farmers set up a young beginner by intrusting to his care a flock of 400 or 500 sheep, which he leads to a distant spot, where he finds plenty of good grass and water; the one-half of all the lambs which are yeaned fall to his share, by which means he soon becomes as rich as his benefactor.

“Though the Dutch company seem evidently to discourage all new settlers, by granting no lands in private property; yet the products of the country

have of late years sufficed not only to supply the isles of France and Bourbon with corn, but likewise to furnish the mother-country with several ship loads. These exports would certainly be made at an easier rate than at present, if the settlements did not extend so far into the country, from whence the products must be brought to the Table-bay by land-carriage, on roads which are almost impassable. The intermediate spaces of uncultivated land between the different settlements are very extensive, and contain many spots fit for agriculture; but one of the chief reasons why the colonists are so much divided and scattered throughout the country, is to be met with in another regulation of the company, which forbids every new settler to establish himself within a mile of another. It is evident, that if this settlement were in the hands of the commonwealth, it would have attained to a great population, and a degree of opulence and splendour of which it has not the least hopes at present; but a private company of East India merchants find their account much better in keeping all the landed property to themselves, and tying down the colonist, lest he should become too great and powerful.

“The wines made at the Cape are of the greatest variety possible. The best, which is made at M. Vander Spy’s plantation of Constantia, is spoken of in Europe, more by report than from real knowledge; 30 leagues (or pipes) at the utmost are annually raised of this kind, and each league sells for about 50l. on the spot. The vines from which it is made were originally brought from Shiraz in Persia. Several other sorts grow in the neighbourhood of that plantation, which produce a sweet rich wine, that generally passes for genuine Constantia in Europe. French plants of burgundy, muscade, and frontignan, have likewise been tried, and have succeeded extremely well, sometimes producing wines superior to those of the original soil. An excellent dry wine, which has a slight agreeable tartness, is commonly drank in the principal families, and is made of Madeira vines transplanted to the Cape. Several low sorts, not entirely disagreeable, are raised in great plenty, and sold at a very cheap rate; so that the sailors of the East India ships commonly indulge themselves very plentifully in them whenever they come ashore.

“The products of the country supply with provisions the ships of all nations which touch at the Cape. Corn, flour, biscuit, salted beef, brandy, and wine, are to be had in abundance, and at moderate prices; and their fresh greens, fine fruits, good mutton and beef, are excellent restoratives to seamen who have made a long voyage.”

HOTTINGER, JOHN HENRY, one of the most learned and eminent of the Protestant divines of Switzerland, was born at Zurich, in the year 1620. He discovered an invincible propensity to learning at a very early period, and acquired the knowledge of languages with astonishing facility. The trustees of the schools had their attention attracted towards Hottinger by his amazing progress in the knowledge of the Hebrew, Greek, and Latin, whom they determined to send to foreign universities at the public expence. In 1638 he studied for a short time at Geneva under the celebrated Spanheim, and went afterwards to France. He next visited Holland and Flanders, and became a student

Hottinger. dent in the university of Groningen, where he attended the theological lectures of the renowned Francis Gomar, and Professor Alting, and studied the Arabic language under Professor Pasor. Being anxious, however, to enjoy still more advantages than this situation afforded, he went to Leyden, where he became tutor to the children of Professor Golius, whose knowledge of oriental languages was at that time unrivalled. By his instructions and those of a Turk then at Leyden, Hottinger's knowledge of the Arabic became very extensive, and Golius allowed him to copy many of the Arabic manuscripts which he had in his possession. In 1641 he was chosen chaplain to the embassy of the states-general to Constantinople; but the magistrates of Zurich would not allow him to accept of it, resolving that his talents should be exerted for the glory and benefit of their own public schools. They permitted him to visit England prior to his return home, where he contracted habits of intimacy with some of the most distinguished literary characters. As soon as he returned to Zurich, he was appointed professor of church-history, when no more than 22 years of age; and when 23, he was chosen professor of catechetical divinity and oriental languages. About this period he married, and began his career as an author, in which he persevered for twenty years, with the most astonishing industry. In 1653 he was appointed professor of rhetoric, and professor extraordinary of the divinity of the Old Testament, and controversial theology.

So justly celebrated about this time was Hottinger as a man of uncommon erudition, that his aid was earnestly requested by the elector palatine, to restore the fame of the university of Heidelberg. The magistrates of Zurich consented to lend him for three years. At Heidelberg he was made professor of divinity, principal, ecclesiastical counsellor, and rector. He wrote in favour of the re-union of Lutherans and Calvinists; but he had no better success than all his predecessors in the same attempt. He continued at Heidelberg, by permission of the magistrates of Zurich, till 1661. On his return home, he was chosen president of the commissioners who were appointed to revise the German translation of the Bible. He was requested to accept of professorships from the magistrates of Deventer, the landgrave of Hesse, and the magistrates of Amsterdam and Bremen; but the love of his country made him reject the whole. He was offered the divinity chair at Leyden in 1667, but the magistrates would not part with him. This made the Dutch request him as a loan, to which the magistrates agreed, from their respect for the states of Holland; but while making preparations for his departure, he was unfortunately drowned in the river which runs through Zurich, while on his way to an estate of his own about six miles from that city.

Dr Hottinger was a man of extraordinary abilities, both natural and acquired, having few equals for his knowledge of oriental languages, and the antiquities of the church. He had a most retentive memory, and his literary industry was almost unexampled. His life was comparatively short, being only 47 when he found a watery grave, yet he was the author of no fewer than 40 volumes, on different subjects. He is frequently inaccurate, owing to the astonishing rapidity with which

he wrote. For a correct list of his publications, see *Hottinger's* *Heidegger's Life of Hottinger.*

HOTTONIA, WATER-VIOLET, a genus of plants belonging to the pentandria class; and in the natural method ranking under the 21st order, *Precia*. See *BOTANY Index*.

HOUBRAKEN, JACOB, a celebrated engraver, whose great excellence consisted in the portrait line. His works are distinguished by an admirable softness and delicacy of execution, joined with good drawing and a fine taste. If his best performances have ever been surpassed, it is in the masterly determination of the features, which we find in the works of Nanteuil, Edlink, and Drevet; this gives an animation to the countenance, more easily to be felt than described. His works are pretty numerous; and most of them being for English publications, they are sufficiently known in this country. In particular the greater and best part of the collection of portraits of illustrious men, published in London by I. and P. Knapton, were by his hand.

HOVEDON, ROGER DE, born of an illustrious family in Yorkshire, most probably at the town of that name, now called *Howden*, some time in the reign of Henry I. After he had received the first parts of education in his native country, he studied the civil and canon law, which were then become most fashionable and lucrative branches of learning. He became domestic chaplain to Henry II. who employed him to transact several ecclesiastical affairs; in which he acquitted himself with honour. But his most meritorious work was his annals of England, from A. D. 731, when Bede's ecclesiastical history ends, to A. D. 1202. This work, which is one of the most voluminous of our ancient histories, is more valuable for the sincerity with which it is written, and the great variety of facts which it contains, than for the beauty of its style, or the regularity of its arrangement.

HOUGH, HAM, in the manege, the joint of the hind leg of a beast, which connects the thigh to the leg. See **HAM**.

To *HOUGH*, or *cut the Houghs*, is to ham-string, or to disable by cutting the sinews of the ham.

HOULIERES, ANTONIETTE DES, a French lady, whose poetry is highly esteemed in France. Her works and those of her daughter have been collected and printed together in two volumes. Most of the idyls, particularly those on sheep and birds, surpass every thing of the kind in the French language: the thoughts and expressions are noble; and the style pure, flowing, and chaste. Mademoiselle des Houlieres carried the poetic prize in the French academy against Fontenelle. Both of these ladies were members of the academy of Ricovatri; the mother was also a member of the academy of Arles. Those who desire to be more particularly acquainted with the history of Madame des Houlieres, may consult her life prefixed to her works in the Paris edition of 1747, 2 vols 12mo.

HOULSWORTHY, a large town of Devonshire, seated between two branches of the river Tamar, having a good market for corn and provisions. It had 1206 inhabitants in 1811. W. Long. 2. 42. N. Lat. 50. 50.

HOUND. See **CANIS**, *BLOOD-Hound*, and *GRE-Hound*.

Training

Hound.

Training of HOUNDS. Before we speak of the methods proper to be used for this purpose, it will be necessary to point out the qualities which sportsmen desire to meet with in these animals. It is generally understood, that hounds of the middle size are the most proper, it being remarked, that all animals of that description are stronger than either such as are very small or very large. The shape of the hound ought to be particularly attended to; for if he be not well proportioned, he can neither run fast nor do much work. His legs ought to be straight, his feet round, and not very large; his shoulders back; his breast rather wide than narrow; his chest deep, his back broad, his head small, his neck thin; his tail thick and bushy, and if he carry it well so much the better. None of those young hounds which are *out at the elbows*, or such as are weak from the knees to the foot, should ever be taken into the pack. That the pack may look well, it is proper that the hounds should be as much as possible of a size: and if the animals be handsome at the same time, the pack will then be perfect. It must not, however, be thought, that this contributes any thing to the *goodness* of a pack; for very unhandsome packs, consisting of hounds entirely different in size and colour, have been known to afford very good sport. It is only necessary that they should run well together; to which indeed an uniformity in size and shape would seem to contribute in some degree. The pack that can run 10 miles, or any other considerable space, in the shortest time, may be said to go fastest, though the hounds taken separately might be considerably inferior to others in swiftness. A pack of hounds, considered in a collective body, go fast in proportion to the excellence of their noses and the head they carry. Packs which are composed of hounds of various kinds seldom run well. When the packs are very large, the hounds are seldom sufficiently hunted to be good; 20 or 30 couple, therefore, or at most 40, will be abundantly sufficient for the keenest sportsman in this country, as thus he may be enabled to hunt three or even four times a-week. The number of hounds to be kept must, however, in a considerable degree, depend on the strength of the pack, and the country in which you hunt. They should be left at home as seldom as possible; and too many old hounds should not be kept. None ought to be kept above five or six seasons, though this also is somewhat uncertain, as we have no rule for judging how long a hound will last.

In breeding of hounds, considerable attention ought to be paid to the dog from whom you breed. All such are to be rejected as have a tender nose, as are *babblers* or *skirters*. An old dog should never be put to an old bitch; nor should any attempts be made to cross the breed unless in a proper and judicious manner. Mr Beckford* informs us, that he has seen fox-hounds bred out of a Newfoundland dog and fox-hound bitch; the whelps were monstrously ugly, and had other bad qualities besides. The cross most likely to be of service to a fox-hound is the beagle. The reason of crossing the breeds sometimes is, that the imperfections of one may sometimes be remedied by another. The months of January, February, and March, are the best for breeding; late puppies seldom thrive. After the females begin to grow big with young, it will not be proper to let them hunt any more, or indeed to re-

* *Essay on Hunting.*

main for a much longer time in the kennel. Sometimes these animals will have an extraordinary number of whelps. Mr Beckford informs us, that he has known a bitch have 15 puppies at a litter; and he assures us, that a friend of his informed him, that a hound in his pack brought forth 16, all of them alive. In these cases it is proper to put some of the puppies to another bitch, if you want to keep them all; but if any are destroyed, the best coloured ought to be kept. The bitches should not only have plenty of flesh, but milk also; and the puppies should not be taken from them till they are able to take care of themselves; their mothers will be relieved when they learn to lap milk, which they will do in a short time. After the puppies are taken away from the mothers, the litter should have three purging balls given them, one every other morning, and plenty of whey the intermediate day. If a bitch bring only one or two puppies, and you have another that will take them, by putting the puppies to her the former will soon be fit to hunt again. She should, however, be first physicked, and it will also be of service to anoint her dogs with brandy and water.

Whelps are very liable to the distemper to which dogs in general are subject, and which frequently makes great havoc among them at their walks; and this is supposed by Mr Beckford to be owing to the little care that is taken of them. "If the distemper (says he) once get among them, they must all have it: yet, notwithstanding that, as they will be constantly well fed, and will lie warm (in a kennel built on purpose), I am confident it would be the saving of many lives. If you should adopt this method, you must remember to use them early to go in couples: and when they become of a proper age, they must be walked out often; for should they remain confined, they would neither have the health, shape, or understanding, which they ought to have. When I kept harriers, I bred up some of the puppies at a distant kennel; but having no servants there to exercise them properly, I found them much inferior to such of their brethren as had the luck to survive the many difficulties and dangers they had undergone at their walks; these were afterwards equal to any thing, and afraid of nothing; whilst those that had been nursed with so much care, were weakly, timid, and had every disadvantage attending private education. I have often heard as an excuse for hounds not hunting a cold scent, that they were too *high-bred*. I confess I know not what that means: but this I know, that hounds are frequently too *ill-bred* to be of any service. It is judgment in the breeder, and patience afterwards in the huntsman, that makes them hunt.

"When young hounds are first taken in, they should be kept separate from the pack; and as it will happen at a time of the year when there is little or no hunting, you may easily give them up one of the kennels and grass court adjoining. Their play frequently ends in a battle; it therefore is less dangerous where all are equally matched.—If you find that they take a dislike to any particular hound, the safest way will be to remove him, or it is probable they will kill him at last. When a feeder hears the hounds quarrel in the kennel, he hallooos to them to stop them; he then goes in among them, and flogs every hound he can come near.

Hound.

How

Hound.

How much more reasonable, as well as efficacious, would it be, were he to see which were the combatants before he speaks to them. Punishment would then fall, as it ought, on the guilty only. In all packs there are some hounds more quarrelsome than the rest; and it is to them we owe all the mischief that is done. If you find chastisement cannot quiet them, it may be prudent to break their holders; for since they are not necessary to them for the meat they have to eat, they are not likely to serve them in any good purpose. Young hounds should be fed twice a-day, as they seldom take kindly to the kennel meat at first, and the distemper is most apt to seize them at this time. It is better not to round them till they are thoroughly settled; nor should it be put off till the hot weather, for then they will bleed too much. It may be better perhaps to round them at their quarters, when about six months old; should it be done sooner, it would make their ears tuck up. The tailing of them is usually done before they are put out; it might be better, perhaps, to leave it till they are taken in. Dogs must not be rounded at the time they have the distemper upon them, as the loss of blood would weaken them too much.

"If any of the dogs be thin over the back, or any more quarrelsome than the rest, it will be of use to cut them; I also spay such bitches as I shall not want to breed from; they are more useful, are stouter, and are always in better order; besides it is absolutely necessary if you hunt late in the spring, or your pack will be very short for want of it. The latter operation, however, does not always succeed; it will be necessary therefore to employ a skilful person, and one on whom you can depend; for if it be ill done, though they cannot have puppies, they will go to heat notwithstanding. They should be kept low for several days before the operation is performed, and must be fed on thin meat for some time after."

It is impossible to determine how many young hounds ought to be bred in order to keep up the pack, as this depends altogether on contingencies. The deficiencies of one year must be supplied by the next; but it is probable, that from 30 to 35 couple of old hounds, and from eight to twelve couple of young ones, will answer the purpose where no more than 40 couple are to be kept. A considerable number, however, ought always to be bred; for it is undoubtedly and evidently true, that those who breed the greatest number of hounds must expect the best pack.

After the hounds have been rounded, become acquainted with the huntsman, and answer to their names, they ought to be coupled together, and walked out among sheep. Such as are particularly ill-natured ought to have their couples loose about their necks in the kennel till they become reconciled to them. The most stubborn ought to be coupled to old hounds rather than to young ones; and two dogs should not be coupled together when you can avoid it. As young hounds are awkward at first, a few ought only to be set out at a time with people on foot, and they will soon afterwards follow a horse. When they have been walked out often in this manner amongst the sheep, they should be uncoupled by a few at a time, and those chastised who offer to run after the sheep; but it will be difficult to reclaim them after they have once been allowed to

VOL. X. Part II.

taste blood. Some are accustomed to couple the dogs with a ram in order to break them from sheep; but this is very dangerous for both parties. Mr Beckford relates a story of a nobleman who put a large ram into his kennel in order to break his hounds from sheep; but when he came some time after to see how nobly the ram defended himself, he found him entirely eaten up, and the hounds gone to sleep after having filled their bellies.

When hounds are to be aired, it is best to take them out separately, the old ones one day, and the young another; though, if they are to have whey from a distant dairy, both old and young may be taken out together, observing only to take the young hounds in couples, when the old ones are along with them. Young hounds are always apt to fall into mischief, and even old ones when idle will be apt to join them. Mr Beckford mentions a whole pack running after a flock of sheep through the mere accident of a horse's falling, and then running away.

With regard to the first entering of hounds to a scent, our author gives such directions as have subjected him to a severe charge of inhumanity. We shall give them in his own words. "You had better enter them at their own game: it will save you much trouble afterwards. Many dogs, I believe, like that scent best which they were first blooded to: but be this as it may, it is most certainly reasonable to use them to that which it is intended they should hunt. It may not be amiss first when they begin to hunt to put light collars on them. Young hounds may easily get out of their knowledge; and shy ones, after they have been much beaten, may not choose to return home. Collars, in that case, may prevent their being lost.—You say you like to see your young hounds run a trail-scent.—I have no doubt that you would be glad to see them run over an open down, where you could so easily observe their action and their speed. I cannot think the doing of it once or twice could hurt your hounds; and yet as a sportsman I dare not recommend it to you. All that I can say is, that it would be less bad than entering them at hare. A cat is as good a trail as any; but on no account should any trail be used after your hounds are stooped to a scent. I know an old sportsman who enters his young hounds first at a cat, which he drags along the ground for a mile or two, at the end of which he turns out a badger, first, taking care to break his teeth; he takes out about a couple of old hounds along with the young ones to hold them on. He never enters his young hounds but at vermin; for he says, Train up a child in the way he should go, and when he is old he will not depart from it."

Hounds ought to be entered as soon as possible, though the time must be uncertain, as it depends on the nature of country in which they are. In corn countries hunting may not be practicable till the corn is cut down; but you may begin sooner in grass countries, and at any time in woodlands. "If (says Mr Beckford) you have plenty of foxes, and can afford to make a sacrifice of some of them for the sake of making your young hounds steady, take them first where you have least riot, putting some of the steadiest of your old hounds among them. If in such a place you are fortunate enough to find a litter of foxes, you may assure yourself you will have but little trouble with

Hound.

4 M

your

Hound. your young hounds afterwards.—If, owing to a scarcity of foxes, you should stoop your hounds at hare, let them by no means have the blood of her; nor, for the sake of consistency, give them much encouragement. Hare-hunting has one advantage;—hounds are chiefly in open ground, where you can easily command them; but notwithstanding that, if foxes be in tolerable plenty, keep them to their own game.—Frequent hallooing is of use with young hounds; it keeps them forward, prevents them being lost, and hinders them from hunting after the rest. The oftener therefore that a fox is seen and halloosed, the better. I by no means, however, approve of much hallooing to old hounds; though it is true that there is a time when hallooing is of use, a time when it does hurt, and a time when it is perfectly indifferent: but long practice and great attention to hunting can only teach the application.

“Hounds at their first entrance cannot be encouraged too much. When they are become handy, love a scent, and begin to know what is right, it will then be soon enough to chastise them for what is wrong; in which case one severe beating will save a great deal of trouble. When a hound is flogged, the whipper-in should make use of his voice as well as his whip. If any be very unsteady, it will not be amiss to send them out by themselves when the men go out to exercise their horses. If you have hares in plenty, let some be found sitting, and turned out before them; and you will find that the most riotous will not run after them. If you intend them to be steady from deer, they should often see deer, and then they will not regard them, and if after a probation of this kind you turn out a cub before them, with some old hounds to lead them on, you may assure yourself they will not be unsteady long.”

It is proper to put the young hounds into the pack when they stoop to a scent, become handy, know a rate, and stop easily. A few only are to be put to the pack at a time; and it is not advisable even to begin this till the pack have been out a few times by themselves, and are “gotten well in blood.” They should be low in flesh when you begin to hunt; the ground being generally hard at that time, so that they are liable to be shaken.—By hounds being *handy*, our author means their being ready to do whatever is required of them; and particularly, when cast, to turn easily which way the huntsman pleases.

Mr Beckford begins to hunt with his young hounds in August. The huntsman in the preceding months keeps his old hounds healthy by giving them proper exercise, and gets his young hounds forward; and for this purpose nothing answers so well as taking them frequently out. The huntsman should go along with them, get frequently off his horse, and encourage them to come to him:—too much restraint will frequently incline the hounds to be riotous. Our author frequently walks out his hounds among sheep, hares, and deer. Sometimes he turns down a cat before them, which they kill; and, when the time of hunting approaches, he turns out young foxes or badgers; taking out some of the most steady of his old hounds to lead on the young ones. Small covers and furze-brakes are drawn with them to use them to a halloo, and to teach them obedience. If they find improper game and hunt it,

they are stopped and brought back; and as long as they will stop at a rate, they are not chastised. At such times as they are taken out to air, the huntsman leads them into the country in which they are designed to hunt; by which means they acquire a knowledge of the country, and cannot miss their way home at any time afterwards. When they begin to hunt, they are first brought into a large cover of his own, which has many ridings cut in it; and where young foxes are turned out every year on purpose for them. After they have been hunted for some days in this manner, they are sent to more distant covers, and more old hounds added to them. There they continue to hunt till they are taken into the pack, which is seldom later than the beginning of September; for by that time they will have learned what is required of them, and seldom give much trouble afterwards. In September he begins to hunt in earnest; and after the old hounds have killed a few foxes, the young ones are put into the pack, two or three couple at a time, till all have hunted. They are then divided; and as he seldom has occasion to take in more than nine or ten couple, one half are taken out one day, and the other the next, till they are steady.

To render fox-hunting complete, no young hounds should be taken into the pack the first season; a requisite too expensive for most sportsmen. The pack should consist of about 40 couple of hounds, that have hunted one, two, three, four or five seasons. The young pack should consist of about 20 couple of young hounds, and an equal number of old ones. They should have a separate establishment, and the two kennels should not be too near one another. When the season is over, the best of the young hounds should be taken into the pack, and the draught of old ones exchanged for them. Many must be bred to enable a sportsman to take in 20 couple of young hounds every season. It will always be easy to keep up the number of old hounds; for when your own draft is not sufficient, drafts from other packs may be obtained, and at a small expence. When young hounds are hunted together for the first season, and have not a sufficient number of old ones along with them, it does more harm than good.

Kennel of HOUNDS. See KENNEL.

HOUNSLOW, a town of Middlesex, 10 miles from London. It is situated on a heath of the same name; and belongs to two parishes, the north side of the street to Heston, and the south side to Isleworth. Near it are powder-mills. It has fairs on Trinity-Monday, and Monday after September 29. Here is a charity-school and a chapel. In this place was formerly a convent of mendicant friars, who, by their institution, were to beg alms for the ransom of captives taken by the infidels.—The heath is noted for robberies and horse-races. Population 2304 in 1811.

HOU-QUANG, a province of China, occupying nearly the centre of the empire: the river Yang-tse-kiang traverses it from west to east, and divides it into two parts, the northern and southern. This province (the greater part of which is level, and watered by lakes, canals, and rivers) is celebrated for its fertility; the Chinese call it the store-house of the empire; and it is a common saying among them, that “the abundance

Hou-quang dance of Kiang-si could furnish all China with a breakfast; but the province of Hou-quang alone could supply enough to maintain all its inhabitants." Some princes of the race of Hong-you formerly resided in this province; but that family was entirely destroyed by the Tartars when they conquered China. The people here boast much of their cotton cloths, simples, gold-mines, wax, and paper made of the bamboo-reed. The northern part of the province contains eight *fou*, or cities of the first class, and sixty of the second and third. The southern comprehends seven of the first class, and fifty-four of the second and third, exclusive of forts, towns, and villages, which are everywhere to be found.

HOUR, in *Chronology*, an aliquot part of a natural day, usually a 24th, but sometimes a 12th. The origin of the word *hora*, or *æra*, comes, according to some authors, from a surname of the sun, the father of hours, whom the Egyptians call *Horus*. Others derive it from the Greek *ἑρμῆς*, to terminate, distinguish, &c. Others from the word *ὑρῆ*, urine; holding, that Trismegistus was the first that settled the division of hours which he did from observation of an animal consecrated to Serapis, named *cynocephalus*, which makes water 12 times a-day, and as often in the night, at equal intervals.

An hour, with us, is a measure or quantity of time, equal to a 24th part of the natural day, or nycthemeron; or the duration of the 24th part of the earth's diurnal rotation. Fifteen degrees of the equator answer to an hour; though not precisely, but near enough for common use. It is divided into 60 minutes; the minute into 60 seconds, &c.

The division of the day into hours is very ancient; as is shown by Kircher, *Oedipt. Egypt.* tom. ii. p. ii. class. vii. c. 8.: though the passages he quotes from Scripture do not prove it.—The most ancient hour is that of the 12th part of the day. Herodotus, lib. ii. observes, that the Greeks learnt from the Egyptians, among other things, the method of dividing the day into twelve parts.—The astronomers of Cathaya, &c. Bishop Beveridge observes, still retain this division. They call the hour *chag*; and to each *chag* give a peculiar name, taken from some animal: The first is called *æth*, "mouse;" the second, *chiu*, "bullock;" the third, *xem*, "leopard;" the fourth, *mau*, "hare;" the fifth, *chia*, "crocodile," &c.

The division of the day into 24 hours, was not known to the Romans before the first Punic war.—Till that time they only regulated their days by the rising and setting of the sun. They divided the 12 hours of their day into four, viz. *prime*, which commenced at six o'clock; *third*, at nine; *sixth*, at twelve, and *none*, at three. They also divided the night into four watches, each containing three hours.

HOURS, *Horæ*, in the ancient mythology, were certain goddesses, the daughters of Jupiter and Themis; at first only three in number, Eunomia, Dica, and Irene, to which were afterwards added two more, Carpo and Thallo.

Homer makes them the doorkeepers of heaven. Ovid allots them the employment of harnessing the horses of the Sun:

Jungere equos Titan velocibus imperat Horis.

And speaks of them as standing, at equal distances, about the throne of Sol:

—*et, posita spatiis equalibus, Horæ.*

The poets represent them as dressed in fine coloured or embroidered robes, and gliding on with a quick and easy motion.

HOURS, *Horæ*, in the Romish church, are certain prayers performed at stated times of the day; as matins, vespers, lauds, &c. The lesser hours are, *prime*, *terce*, *sixth*, and *none*. They are called *hours* or *canonical hours*, as being to be rehearsed at certain hours prescribed by the canons of that church, in commemoration of the mysteries accomplished at those hours. These hours were anciently also called *course*, *curvus*: F. Mabillon has a dissertation on them, entitled, *De Curvu Gallicano*.

The first constitution enjoining the observation of the canonical hours is of the ninth century, being found in a capitular of Heito bishop of Basil directed to his curates, importing that the priests shall never be absent at the canonical hours either by day or night.

Hour-Glass, a popular kind of chronometer or clepsydra, serving to measure the flux of time by the descent or running of sand out of one glass vessel into another. The best hour-glasses are those which, instead of sand, have egg-shells well dried in the oven, then beaten fine and sifted.—Hour-glasses are much used at sea for reckoning, &c.

HOURIS, in modern history, is a name given by the Mahometans to those females that are designed for the faithful in Paradise. These are not the same with whom they have lived on earth, but formed for this purpose with singular beauty and undecaying charms.

HOUSE, a habitation, or place built with conveniences for dwelling in. See ARCHITECTURE.

HOUSES, among the Jews, Greeks, and Romans, were flat on the top for them to walk upon, and had usually stairs on the outside, by which they might ascend and descend without coming into the house. Each house, in fact, was so laid out, that it enclosed a quadrangular area or court. This court was exposed to the weather, and being open to the sky, gave light to the house. This was the place where company was received, and for that purpose it was strewed with mats or carpets for their better accommodation. It was paved with marble or other materials, according to the owner's ability, and provided with an umbrella of vellum to shelter them from the heat and inclemencies of the weather. This part of their houses, called by the Romans *impluvium* or *cava ædium*, was provided with channels to carry off the water into the common sewers. The top of the house was level, and covered with a strong plaster by way of terrace. Hither, especially among the Jews, it was customary to retire for meditation, private converse, devotion, or the enjoyment of the evening breezes.

The Grecian houses were usually divided into two parts, in which the men and women had distinct mansions assigned. The part assigned to the men was towards the gate, and called *andronitis*; the apartment of the women was the farthest part of the house, and called *gynaecitis*. Jews, Greeks, and Romans, supposed

House. sed their houses to be polluted by dead bodies, and to stand in need of purification.

HOUSE is also used for one of the estates of the kingdom of Britain assembled in parliament. Thus we say, the house of lords, the house of commons, &c. See **PEERS, COMMONS, &c.**

HOUSE is also used for a noble family, or a race of illustrious persons issued from the same stock. In this sense we say, the house or family of the Stuarts, the Bourbons, the house of Hanover, of Austria, of Lorraine, of Savoy, &c.

Cheap, easy, and expeditious Method of constructing Houses, which have been found to be very useful hospitals for the recovery of the sick, and therefore may probably make very wholesome places of residence for the healthy.—The first thing to be done is to choose a dry and airy situation, on a gravelly or chalky soil if possible; upon this lay down the plan of your building, make one end of it face that quarter from whence the purest and healthiest winds may be expected to blow, of a breadth that can be conveniently roofed. Then, if boarding does not come so cheap, drive stakes, at about six feet distance from each other, into the ground, so as to stand about six feet above it; and, interlacing them with wattles, coat the wattles on the side next the weather with fresh straw; and make the roof in the same manner, but thicker, or of thatch in the usual way, with a hole at the very top of it, to open occasionally. Let the end of the building facing the wholesomest quarter lie open some feet back, so as to form a porch, where the convalescents may take the air without danger of any injury from the weather. A large chimney and kitchen grate may be erected at the other end. If the soil happens to be chalky or gravelly, you may hollow it four or five feet deep, within a foot or eighteen inches of the walls; but let the steps into this hollow lie far enough within the porch, that no water may get into it, and, if of chalk, the steps may not grow slippery in wet weather. From time to time open the vent-hole at the roof; by means of which all the unwholesome infectious air, as being warmer, and consequently lighter, than that which is pure and wholesome, will be driven out by the rushing in of the fresh air; a purpose, which the little openings that may be left in the sides and roofs of such rude and hasty buildings, will, even of themselves, answer so well, as sufficiently to compensate any cold they may let in, even in the coldest months. Let the floor likewise be scraped three or four inches deep every five or six days, and what comes off removed to some distance. Halls of this kind, 50 feet long and 20 broad, cost but a trifle to build; yet, with these precautions (even without the addition of clean straw for every new patient to lie on, inclosed in clean washed sacks fit for the purpose, which come infinitely cheaper than the bare cleaning of flock or even feather-beds, supposing it possible to wash such beds), proved of infinitely more advantage in the recovery of sick soldiers, than the low-roofed rooms of the farm-houses of the Isle of Wight, or even the better accommodations of Carisbrooke castle in the same island, in which there perished four times the number of sick that there did in these temporary receptacles; which were first thought of by Doctor Brocklesby, on occasion

of some terrible infections from confined animal effluvia.

Is it not surprising, that we have not availed ourselves more of the above discovery in natural history, being, perhaps, the most important the moderns can boast of, in the most useful science, viz. the superior lightness of unwholesome and infectious air! The upper sashes in most houses, even of those who pretend to some knowledge in these matters, are generally immovable, by means of which no part of the foul air above the level of the lowest rail of the other sash's greatest rise can escape by the window; and, if it escapes by the doors, it is generally, for want of a vent in the highest part of the roof, merely to accumulate in the upper story of the house, and add to the infection, which the great quantities of old furniture usually stored up there are of themselves but too apt to create, when care is not frequently taken to open the windows of it. Thus, the chief benefit to be expected from lofty rooms is in a great measure lost. Whereas, were the upper sashes contrived to come down, all the air might be easily changed, and that almost insensibly, by letting them down an inch or two. Nay, the upper sash might be often let entirely down with less danger or inconvenience from cold, than the lower thrown up the tenth part of an inch, though the doing of the former would be attended with infinitely more advantage to the health of the inhabitants than the latter. It is, perhaps, on this principle, that we are to account for the good health enjoyed by the poor who live crowded in damp cellars, and often with great numbers of rabbits, poultry, and even swine about them. These cellars are open to the street, with doors reaching from the floor to the very ceiling, but never so close at bottom or at top as to prevent a free circulation of air; in consequence of which, that all-vivifying fluid, as fast as it is spoiled by passing through the lungs of the inhabitants and their stock, or is infected by their insensible perspiration, excrements, &c. is driven out and replaced by the fresh air.

HOUSE, in *Astrology*, denotes the twelfth part of the heavens.

The division of the heavens into houses is founded upon the pretended influence of the stars, when meeting in them, on all sublunary bodies. These influences are supposed to be good or bad; and to each of these houses particular virtues are assigned, on which astrologers prepare and form a judgment of their horoscopes. The horizon and meridian are two circles of the celestial houses, which divide the heavens into four equal parts, each containing three houses; six of which are above the horizon, and six below it; and six of these are called *eastern* and six *western houses*.

A scheme or figure of the heavens is composed of 12 triangles, all called *houses*, in which are marked the stars, signs, and planets, so included in each of these circles. Every planet has likewise two particular houses, in which it is pretended that they exert their influence in the strongest manner; but the sun and moon have only one, the house of the former being *Leo*, and that of the latter *Cancer*.

The houses in astrology have also names given them according to their qualities. The first is the house of life:

House. life: this is the ascendant, which extends five degrees above the horizon, and the rest below it. The second is the house of riches; the third, the house of brothers; the fourth, in the lowest part of the heavens, is the house of relations, and the angle of the earth; the fifth, the house of children; the sixth, the house of health; the seventh, the house of marriage, and the angle of the west; the eighth, the house of death; the ninth, the house of piety; the tenth, the house of offices; the eleventh, the house of friends; and the twelfth, the house of enemies.

* See *Villa*. **Country HOUSE**, is the *villa** of the ancient Romans, the *quinta* of the Spaniards and Portuguese, the *closerie* and *cassine* of the French, and the *vigna* of the Italians.

It ought always to have wood and water near it, these being the principal beauties of a rural seat. The trees make a far better defence than hills, as they yield a cooling and healthy air, shade during the heat of summer, and very much break the severities of the winter season.

It should not be situated too low, on account of the moisture of the air; and, on the other hand, those built on places exposed to the winds are expensive to keep in repair. In houses not above two stories high, and upon a good foundation, the length of two bricks, or 18 inches, for the heading course, will be sufficient for the ground-work of any common structure; and six or seven courses above the earth, to a water-table, where the thickness of the walls is abated or taken in, on either side the thickness of a brick, viz. two inches and a quarter. But for large and high houses of three, four, or five stories, with garrets, their walls ought to be three heading courses of bricks, or 28 inches at least, from the foundation to the first water-table; and at every story a water-table, or taking in, on the inside, for the summers, girders, and joists to rest upon, laid into the middle, or one quarter of the wall at least, for the better bond. But as for the partition-wall, a brick and half will be sufficiently thick; and for the upper stories a brick length or nine inch brick will suffice.

Hot-HOUSE. See STOVE and HYPOCAUSTUM.

HOUSE-Breaking, or *Robbing*, is the breaking into and robbing a house in the day-time; the same crime being termed BURGLARY when done by night: both are felony without benefit of clergy.

† See *Revenue*. **HOUSE and Window Duty**, a branch of the king's extraordinary revenue †.—As early as the Conquest, mention is made in Doomesday book of fumage or fuge, vulgarly called *smoke-farthings*; which were paid by custom to the king for every chimney in the house. And we read that Edward the Black Prince (soon after his successes in France), in imitation of the English custom, imposed a tax of a florin upon every hearth in his French dominions. But the first parliamentary establishment of it in England was by statute 13 and 14 Car. II. c. 10. whereby an hereditary revenue of 2s. for every hearth, in all houses paying to church and poor, was granted to the king for ever. And, by subsequent statutes, for the more regular assessment of this tax, the constable and two other substantial inhabitants of the parish, to be appointed yearly (or the surveyor appointed by the crown, together with such constable or other public officer), were, once in every year, em-

powered to view the inside of every house in the parish. But, upon the Revolution, by stat. 1 W. and M. c. 10. hearth-money was declared to be "not only a great oppression to the poorer sort, but a badge of slavery upon the whole people, exposing every man's house to be entered into and searched at pleasure, by persons unknown to him; and therefore, to effect a lasting monument of their majesties goodness, in every house in the kingdom the duty of hearth-money was taken away and abolished." This monument of goodness remains among us to this day: but the prospect of it was somewhat darkened, when in six years afterwards, by statute 7 W. III. c. 18. a tax was laid upon all houses (except cottages) of 2s. now advanced to 3s. per house, and a tax also upon all windows, if they exceeded nine, in such house. These rates have been from time to time varied, being now extended to all windows exceeding six; and power is given to surveyors, appointed by the crown, to inspect the outside of houses, and also to pass through any houses, two days in the year, into any court or yard, to inspect the windows there.

Schemes of the different rates of duty upon houses and windows may be seen in the *Almanacks*, or in *Kearsleg's Tax-Tables* published yearly.

HOUSE-LEEK. See SEDUM and SEMPERVIVUM, BOTANY Index.

HOUSEHOLD, the whole of a family considered collectively, including the mistress, children, and servants. But the household of a sovereign prince includes only the officers and domestics belonging to his palace.

The principal officers of his majesty's household are, the lord steward, lord chamberlain of the household, the groom of the stole, the master of the great wardrobe, and the master of the horse.

The civil government of the king's house is under the care of the lord steward of the king's household; who, being the chief officer, all his commands are observed and obeyed. His authority extends over all the other officers and servants, except those of his majesty's chapel, chamber, and stable, and he is the judge of all crimes committed either within the court or the verge.

Under him are the treasurer of the household, the comptroller, cofferer, the master of the household, the clerks of the green-cloth, and the officers and servants belonging to the accounting-house, the marshalsea, the verge, the king's kitchen, the household kitchen, the acatery, bake-house, pantry, buttery, collar, pastry, &c. Next to the lord steward is the lord-chamberlain of the household, who has under him the vice-chamberlain, the treasurer, and comptroller of the chamber; 48 gentlemen of the privy chamber, 12 of whom wait quarterly, and two of them lie every night in the privy-chamber; the pages of the presence-chamber; the mace-bearers, cup-bearers, carvers, musicians, &c. See *LORD CHAMBERLAIN of the Household*.

The groom of the stole has under him the 11 other lords of the bed-chamber, who wait weekly in the bed-chamber, and by turns lie there a-nights on a pallet-bed; and also the grooms of the bed-chamber, the pages of the bed-chamber and back-stairs, &c. See *GROOM of the STOLE*.

The master or keeper of the great wardrobe has under

Houshold der him a deputy, comptroller, clerk of the robes, brusher, &c. and a number of tradesmen and artificers, who are all sworn servants to the king.

Hou-tonia.

The master of the horse has under his command the equerries, pages, footmen, grooms, coachmen, farriers, saddlers, and all the other officers and tradesmen employed in his majesty's stables.

Next to the civil list of the king's court, is the military, consisting of the band of gentlemen pensioners, the yeomen of the guards, and the troops of the household; of which the two first guard the king above stairs.

When the king dines in public, he is waited upon at table by his majesty's cup-bearers, carvers, and gentlemen sewers; the musicians playing all the time. The dinner is brought up by the yeomen of the guard, and the gentleman sewers set the dishes in order. The carvers cut for the king, and the cup-bearer serves him the drink with one knee on the ground, after he has first tasted it in the cover.

HOUSING, or *Housse-Line*, in the sea-language, a small line, formed of three fine strands or twists of hemp, smaller than rope-yarn. It is chiefly used to seize blocks into their strops, to bind the corners of the sails, or to fasten the bottom of a sail to its bolt-rope, &c. See *Bolt-Rope*.

HOUSING, or *Housee*, a cover laid over the saddle of a horse, in order to save it from the weather, dirt, &c. The word is formed of the French *houssie*, which signifies the same thing; though it anciently denoted a kind of hood worn by country people.—The cavaliers appeared with their embroidered housings.

HOUSING, among bricklayers, a term used for a brick which is warped, or is cast crooked or hollow in burning; in such a case, they say it is *housing*.

HOUSSA, the metropolis of an empire in Africa, on the banks of the Niger, the population of which, according to the account of an Arab named *Shabeni*, which he delivered to the African Association, was only equalled by that of London and Cairo. The same person described the government as a limited monarchy, which administered justice in a severe manner, although in conformity to written laws. The rights of landed property are guarded by the institutions of particular hereditary officers, whose duties imply no ordinary degree of refinement and civilization. The merchants of Houssa have been celebrated for their probity, while the ladies are said not to be very remarkable for their conjugal fidelity. The art of writing is common, but their alphabet is entirely different from the Arabic and Hebrew. These observations appear to be confirmed by the testimony of Mr Park; and to such as may be disposed to doubt the possibility of so much refinement in the interior of a country deemed savage, it will be necessary to observe, that many of the Carthaginians may have retired to the southern parts of Africa, on the destruction of their own cities, and carried with them some portion of the arts, sciences, and commercial knowledge, for the knowledge of which we are assured that their ancestors were once so famous. According to some maps of North Africa, particularly that of Major Rennel, the city of Houssa lies in Lat. 16. 20. N. and Long. 4. 30. E.

HOUSTONIA, a genus of plants belonging to the

tetrandria class and in the natural method ranking under the 47th order, *Stellata*. See *BOTANY Index*.

HOU-TCHEOU-FOU, a city of China, in the province of Tche-kiang. It is a city of the first class; and is situated on a lake, from which it takes its name. The quantity of silk manufactured here is almost incredible. To give some idea of it we shall only say, that the tribute paid by a city under its jurisdiction, named *Te-tsin-hien*, amounts to more than 500,000 *taels* or ounces of silver. Its district contains seven cities, one of which is of the second, and six of the third, class.

HOZOUANAS, a wandering people, whose country, according to M. Vaillant, is situated between 16° and 29° E. Long. but in what latitude appears to be unknown, although it is extremely probable that it commences about the 23d parallel, and stretches towards the north a considerable way. It is the opinion of the above-mentioned author, that the Houzouanas are the origin of all the eastern and western tribes of the Hottentots: and as to the Houzouanas themselves, they seem wholly ignorant of their own origin; for when they are interrogated upon this subject, their answer invariably is, that they live in the country which their ancestors inhabited, which in point of information is no answer at all. They have been often confounded by the planters with the Boshmen, who are not a distinct people, but a band of fugitives and freebooters. The Houzouanas have nothing in common with them, and only form alliances among themselves. So great are their courage and habits of plunder, that all surrounding nations are afraid of them, and even the very Hottentots, according to Vaillant, tremble to enter their territories. They are often guilty of shedding human blood, yet this does not appear to originate from an innate love of carnage, but merely for the purpose of making just reprisals.

They survey the adjacent countries from the summits of their mountains, and make incursions to carry off cattle or slaughter them upon the spot; but although they rob, they never kill, except in their own defence, or by way of retaliation, so that they are by no means the unrelenting cannibals which some have represented them. Like the Arabs, who are also plunderers, they adhere with unshaken fidelity to their engagements, and the traveller who puts himself under their protection by civilly purchasing their services, may rest assured of being defended to the last drop of their blood; which is more than can be said for the people of many countries professing to be civilized.

Amidst all this superiority to the other natives of Southern Africa, their stature is low, so that a person among them measuring five feet four inches in height, is considered as very tall;—a proof that intellectual excellence is not always to be met with in men of a gigantic stature. Their complexion is not so black as that of the Hottentots, but their heads are rounder towards the chin. The heat of the climate renders clothing unnecessary, and the constant habit of going naked, makes them equally indifferent to the burning sands of the level country, or the frost and snow of the lofty mountains. They have no weapons but bows and arrows, in the use of which they discover remarkable dexterity. Their huts appear as if cut vertically through the middle, so that it would require two of them exactly

Houston

Houssou

naa

Houzoanas, Howard. ly to make one of the Hottentots. The Houzoanas are remarkably nimble, considering the climbing of mountains as nothing more than an amusement; and they conducted M. Vaillant, that traveller informs us, over such tremendous precipices as the Hottentots would have deemed wholly impassable. The practice of making signals by means of nocturnal fires, is known in all savage countries; but the Houzoanas are said to display such uncommon sagacity and prudence in the arrangement and variations of position from time to time, as to render it impossible for the surrounding tribes to penetrate their designs.

HOWARD, HENRY, earl of Surrey, a soldier and a poet, the son and grandson of two lord treasurers, dukes of Norfolk, was born probably about the year 1520, and educated in Windsor castle, with young Fitzroy earl of Richmond, natural son to King Henry VIII. Wood says, from tradition, that he was some time a student at Cardinal College, Oxford. In his youth he became enamoured of the Fair Geraldine, whom his sonnets have immortalized. In 1532, Howard with his companion Richmond was at Paris, where they continued some time. The latter died in 1536; after which our young hero made a tour to Italy, and at Florence, like a true *enamorado*, published a challenge against all comers, whether Christians, Jews, Saracens, Turks, or cannibals, in defence of the beauty of his fair Geraldine; and was victorious in the tournament instituted by the grand duke on the occasion. The duke, we are told, was so charmed with his gallant exploits, that he would gladly have retained him at his court; but he rejected the invitation, being determined to maintain the superlative beauty of his Geraldine in all the principal cities in Italy. This romantic resolution was however frustrated by the command of his sovereign, Henry VIII. to return to England.

In 1540, he signalized himself in a tournament at Westminster, against Sir John Dudley, Sir Thomas Seymour and others. In 1542, he marched, under the command of his father, against the Scots; and in the same year was confined in Windsor castle for eating flesh in Lent, contrary to the king's proclamation. In 1544, on the expedition to Boulogne in France, he was appointed field-marshal of the English army; and after the taking of that town, in 1546, made captain-general of the king's forces in France. He was at this time knight of the Garter. In the same year, attempting to intercept a convoy, he was defeated by the French, and soon after superseded in his command by the earl of Hertford.

Surrey, after his return to England, conscious of his former services, and peevish under his disgrace, could not help reflecting on the king and council. This was his first step towards destruction. He had married Frances, the daughter of John earl of Oxford; and, after her death, is said to have made love to the princess Mary. For this the Seymours, rivals of the Norfolk family, and now in favour with the king, accused him of aspiring to the crown, adding, that he already presumed to quarter part of the royal arms with his own: but, whatever might be the pretence, the cause of his ruin was the jealousy and power of his enemies. In short, the destruction of the Howards being determined, Surrey, and his father, the duke of Norfolk,

were committed to the Tower, in December 1546; and on the 13th of January following, Surrey was tried at Guildhall by a common jury, and beheaded on Tower-hill on the 19th day of the same month, nine days before the death of the king; who thus, that the measure of his crimes might be full, finished his life with the murder of his best subject. The accusations brought against this amiable and innocent young nobleman on his trial, were so extremely ridiculous, that one is astonished how it was possible, even in the most despotic reign, to find a judge and jury so pusillanimously villanous as to carry on the farce of justice on the occasion. We boast of our excellent constitution, and our trial by juries; but this example may teach us, that our constitution and our juries are not incompatible with despotic monarchy. He was first interred in the church of All-hallows, Barkin, near Tower-hill; and afterwards in the reign of King James I. removed to Farmingham in Suffolk, by his son Henry earl of Northampton.

As to the character of this unfortunate earl, all our poets have sung his praise. Mr Walpole begins his anecdotes of Surrey with these words: "We now emerge from the twilight of learning to an almost classic author, that ornament of a boisterous, yet not unpolished court, the earl of Surrey, celebrated by Drayton, Dryden, Fenton, Pope, illustrated by his own muse, and lamented for his unhappy death: a man (as Sir Walter Raleigh says) no less valiant than learned, and of excellent hopes." Leland calls him the conscript enrolled heir of Sir Thomas Wyatt, the elder, in his learning and other excellent qualities; and the author of *The Art of English Poetry* says, that the earl of Surrey and Sir Thomas Wyatt, may be justly called the *reformers of our poetry and style*. His poems were published in 1557, 12mo; and in 1565, 1574, 1585, 1587, 8vo. Several of the sonnets are by Sir Thomas Wyatt and others.

HOWARD, Charles, an able statesman and experienced seaman, was the son of Lord William Howard, baron of Effingham, and born in 1536. He served under his father, who was lord high admiral of England, till the accession of Queen Elizabeth. In January 1573, he succeeded his father in his title and estate; after which he successively became chamberlain of the household and knight of the Garter, and in 1585 was made lord high admiral, at that critical juncture when the Spaniards were sending their ARMADA, in their opinion, to the assured conquest of this kingdom. When he received intelligence of the approach of the Spanish fleet, and saw the prodigious consequence it was to get out the few ships that were ready at Plymouth, he not only gave orders in every thing himself, but wrought also with his own hands, and the first night left the port with six ships. The next morning, though he had only 30 sail, and those the smallest of the fleet, he attacked the Spanish navy; but first dispatched his brother-in-law, Sir Edward Hobby, to the queen, to desire her to make the proper disposition of her land-forces for the security of the coast, and to hasten as many ships as possible to his assistance. His valour was conspicuously displayed in his repeated attacks of a superior enemy. The coolness of his temper was no less conspicuous; and it was owing to his magnanimity and prudence that the victory was so great. The queen

Howard. expressed her sense of his merit in the most honourable terms; and granted him a pension for life. In 1596, he commanded in chief at sea, as Essex did by land, the forces sent against Spain, when his prudence and moderation were among the principal causes of the success the English met with in that great and glorious enterprise; so that, upon his return the next year he was advanced to the dignity of earl of Nottingham. The next eminent service in which his lordship was engaged was in 1599, when the Spaniards seemed to meditate a new invasion. Her majesty, who always placed her safety in being too quick for her enemies, drew together, in a fortnight's time, such a fleet, and such an army, as took away all appearance of success from her foreign and domestic enemies; and she gave the earl the sole and supreme command of both the fleet and army, with the title of *lord lieutenant general of all England*, an office unknown in succeeding times. When age and infirmity had unfitted him for action, he resigned his office, and spent the remaining part of his life in ease and retirement, till the time of his decease, which happened in 1624, in the 87th year of his age.

HOWARD, John, Esq. a man of singular and transcendent humanity, was the son of a reputable tradesman in St Paul's church-yard. He was born about the year 1725 or 1726; and at a proper age was put apprentice to Mr Nathaniel Newnham, a wholesale grocer in Watling street. His father died, leaving only this son and a daughter, to both of whom he bequeathed handsome fortunes; and by his will directed that his son should not be considered of age till he was five and twenty. His constitution was thought very weak, and his health appeared to have been injured by the necessary duties of his apprenticeship; and therefore, at the expiration of it, he took an apartment in a lodging house in Church-street, Stoke Newington, Middlesex; but not meeting with the tenderest treatment there, he removed to another lodging-house in the same street, which was kept by a widow lady Mrs Sarah Lardeau, a worthy sensible woman, but an invalid. Here he was nursed with so much care and attention, that he resolved to marry his landlady out of gratitude for her kindness. In vain she expostulated with him upon the extravagance of such a proceeding, he being about 28 and she about 51 years of age, and 20 years older in constitution: but nothing could alter his resolution, and they were privately married about the year 1752. She was possessed of a small fortune, which he presented to her sister. During his residence at Newington, the minister of the dissenting meeting-house there resigned his office, and a successor was elected; and Mr Howard, who was bred a dissenter, and stedfastly adhered all his life to that profession, proposed to purchase the lease of a house near the meeting-house, and to appropriate it as a parsonage-house for the use of the minister for the time being, and contributed 50l. for that purpose. His wife died November 10. 1755, aged 54; and he was a sincere and affectionate mourner for her death. About this time it is believed, he was elected F. R. S. In the year 1756 he had the fortune to experience some of the evils which it afterwards became the business of his life to redress. He embarked that year in a Lisbon packet, the *Hanover*, in order to make the tour of Portugal; when the vessel was taken by a French privateer. "Be-

fore we reached Brest (says he*) I suffered the extremity of thirst, not having for above 40 hours one drop of water, nor hardly a morsel of food. In the castle at Brest I lay six nights upon straw; and observing how cruelly my countrymen were used there and at Morlaix, whither I was carried next, during the two months I was at Carhaix upon parole, I corresponded with the English prisoners at Brest, Morlaix, and Dinan: at the last of those towns were several of our ship's crew, and my servant. I had sufficient evidence of their being treated with such barbarity, that many hundreds had perished, and that 36 were buried in a hole at Dinan in one day. When I came to England, still on parole, I made known to the commissioners of sick and wounded seamen the sundry particulars, which gained their attention and thanks. Remonstrance was made to the French court: our sailors had redress; and those that were in the three prisons mentioned above, were brought home in the first cartel ships.—Perhaps (adds Mr Howard) what I suffered on this occasion increased my sympathy with the unhappy people whose case is the subject of this book."

He afterwards, it is said, made the tour of Italy; and at his return settled at Brokenhurst, a retired and pleasant villa in the New Forest, near Lymington in Hampshire, having, April 25. 1758, married a daughter of Edward Leeds, Esq. of Croxton, Cambridgeshire, king's serjeant. This lady died in 1765 in child-bed, of her only child, a son, who unfortunately became lunatic. After her death Mr Howard left Lymington, and purchased an estate at Cardington, near Bedford.

"While he lived here in retirement (says Mr Palmer †), it was his meat and drink to make his neighbours happy. His neat but humble mansion was ever hospitable to a few select friends, but was never the scene of riot or luxurious banqueting. Though polite to all, he neither sought nor admitted the company of the profligate, however distinguished by rank or fortune.—His charity had no bounds, except those of prudence; and was not more commendable for the extent of it, than for the manner in which it was exercised. He gave not his bounty to countenance vice and idleness, but to encourage virtue and industry. He was singularly useful in furnishing employment for the labouring poor of both sexes, at those seasons when a scarcity of work rendered their situation most compassionate. And at other times, though never inattentive to the tale of woe, he was not easily imposed upon by it, but made himself acquainted with the case. He had indeed a general acquaintance with the cases and characters of the poor around him, and made it his business to visit the abodes of affliction. In circumstances of bodily disorder, he often acted the part of a physician as well as a friend. But his kindness was not confined to the bodies of his fellow-creatures, it extended to their spiritual and immortal part. He carefully watched over the morals of his neighbourhood, and used his advice, his admonitions, and influence, to discountenance immorality of all kinds, and to promote the knowledge and practice of religion. As a most effectual means to this great end, he provided for the instruction of poor children, by erecting and supporting schools which he carefully superintended. In short, he was an universal blessing to the vil-

Howard.
* *On Pri-*
sons, 4to,
1784, p. 11

† *Funeral*
Sermons on
the death of
Mr How-
ard.

Howard. lage where he resided, in every part of which are to be seen the pleasing monuments of his munificence and taste.—His liberality extended also to adjacent places, in which there are many who will call him blessed. Nor was it confined to persons of his own religious persuasion, but comprehended the necessitous and deserving of all parties; while he was particularly useful in serving the interest of the Christian society to which he belonged. What wonder if such a man were universally beloved? Was it possible he should have an enemy? One however he had (and I never heard of more), an idle and dissolute wretch, who, having been often reproved by him for his vices, formed the desperate resolution to murder him as he was going to public worship, which he almost always did on foot. But providence remarkably interposed to preserve so valuable a life, by inclining him that morning to go on horseback a different road."

But the sphere in which he had hitherto moved was too narrow for his enlarged mind. Being named in 1773 to the office of sheriff of Bedfordshire, from that time his scene of usefulness was extended. His office, as he himself observes, brought the distress of prisoners more immediately under his notice. A sense of duty induced him personally to visit the county-jail, where he observed such abuses and such scenes of calamity, as he had before no conception of; and he soon exerted himself in order to a reform. With a view to obtain precedents for certain regulations which he proposed, he went to inspect the prisons in some neighbouring counties. But finding in them equal room for complaint and commiseration, he determined to visit the principal prisons in England. The farther he proceeded, the more shocking were the scenes presented to his view: which induced him to resolve upon exerting himself to the utmost, in order to a general reform in these horrid places of confinement; considering it as of the highest importance, not only to the wretched objects themselves, but to the community at large. Upon this subject he was examined in the house of commons in March 1774, when he had the honour of their thanks. This encouraged him to proceed in his design. He revisited all the prisons in the kingdom, together with the principal houses of correction. He also in 1775 enlarged his circuit by going into Wales, Scotland, and Ireland, where he found the same need of reformation.

One grand object which he had in view was, to put a stop to that shocking distemper called the *jail-fever*; which raged so dreadfully in many of the prisons as to render them to the last degree offensive and dangerous: A distemper, by which more had been taken off than by the hands of the executioner; and which, in several instances, had been communicated from the prisons into the courts of justice, and had proved fatal to the magistrates and judges, and to multitudes of persons who attended the trials, as well as to the families of discharged felons and debtors. Another end he proposed was, to procure the immediate release of prisoners, who, upon trial, were acquitted, but who often continued long to be unjustly detained for want of being able to pay the accustomed fees: As also to abolish many other absurd and cruel usages which had long prevailed. But the great object of all was, to introduce a thorough reform of morals into our prisons; VOL. X. Part II. †

Howard. where he had found the most flagrant vices to prevail in such a degree, that they were become seminaries of wickedness and villany, and the most formidable nuisances to the community; in consequence of the promiscuous intercourse of prisoners of both sexes, and of all ages and descriptions; whereby the young and less experienced were initiated, by old and hardened sinners, into all the arts of villany and the mysteries of iniquity; so that, instead of being reformed by their confinement (which should be the chief end of punishment), those that were discharged became more injurious to society than before.

In order to the attainment of these great objects, Mr Howard spared no pains nor expence, and cheerfully exposed himself to much inconvenience, and hazard; particularly from that malignant distemper, of which he saw many dying in the most loathsome dungeons, into which none, who were not obliged, besides himself, would venture. "I have been frequently (says Mr Howard) asked what precautions I used to preserve myself from infections in the prisons and hospitals which I visited. I here answer, next to the free goodness and mercy of the Author of my being, temperance and cleanliness are my preservatives. Trusting in divine providence, and believing myself in the way of my duty, I visit the most noxious cells; and while thus employed, I fear no evil. I never enter an hospital or prison before breakfast; and in an offensive room, I seldom draw my breath deeply."

His laudable endeavours he had the pleasure to see, in some instances, crowned with success; particularly in regard to the healthiness of prisons, some of which were rebuilt under his inspection. Through his interposition also, better provision has been made for the instruction of prisoners, by the introduction of bibles and other pious books into their cells, and a more constant attendance of clergymen. The gaolers likewise have, by act of parliament, been rendered incapable of selling strong liquors, which had been the source of much drunkenness and disorder. But a minute detail of particulars is not to be expected here; for these the reader is referred to Mr Howard's publications, which show that much is yet wanting.

But in order to a more general and happy regulation, and the reformation of criminals, he determined to visit other countries, to see the plans there adopted; in hope of collecting some information which might be useful in his own country. For this purpose he travelled into France, Flanders, Holland, Germany, and Switzerland. Afterwards through the Prussian and Austrian dominions. He visited also the capitals of Denmark, Sweden, Russia, and Poland, and some cities in Portugal and Spain. In all these expensive and hazardous journeys, he denied himself the usual gratifications of travellers, and declined the honours which were offered him by persons of the first distinction, applying himself solely to his one grand object. To him the inspection of a jail, or hospital, was more grateful than all the entertainments of a palace. With what astonishment and gratitude he was received by their miserable inhabitants may easily be imagined, since while he made observations on their situation, he meditated their relief; and many distressed prisoners abroad, as well as at home, partook of his bounty, and some were liberated by it; for he considered all of every na-

Howard. ties, and people, and tongue, as brethren. Nor was he sparing of advice, or of reproof, as he saw occasion, to persons of rank and influence, whereby the miseries of their countrymen might be relieved. As he courted the favour of none, neither did he fear the frowns of any; but with a manly freedom and a Christian fortitude, spoke his mind to crowned heads (particularly the late emperor of Germany) in a manner to which they were not accustomed; which, however, in a person of such disinterested views, procured him reverence and esteem, and in some instances proved effectual for relieving the miserable and oppressed. On his return, he published in 1777, "The State of the Prisons in England and Wales, with Preliminary Observations, and an Account of some foreign Prisons." 4to. And in 1778 he took a third journey through the Prussian and Austrian dominions, and the free cities of Germany, and likewise extended his tour through Italy, and revisited some of the countries he had before seen. The observations he made in this tour were published in an appendix, 1780; containing also some remarks respecting the management of prisoners of war, and the hulks on the Thames. But wishing to acquire some further knowledge on the subject, he in 1781 again revisited Holland and some cities in Germany. He visited also the capitals of Denmark, Sweden, Russia, and Poland; and in 1783 some cities in Portugal and Spain, and returned through France, Flanders, and Holland. The substance of all these travels was afterwards thrown into one narrative, which was published in 1784. He also published a curious account of the Bastille, in 8vo.; that infamous French prison, happily now no more.

His travels and exertions, however, were not yet at an end. He conceived a further design, which was to visit the principal lazarettoes in France and Italy, in order to obtain information concerning the best methods to prevent the spreading of the plague, with a view to apply them with respect to other infectious disorders. Not gaining all the satisfaction here which he wished for, he proceeded to Smyrna and Constantinople, where that most dreadful of human distempers actually prevailed, "pleasing himself (as he said) with the idea of not only learning, but of being able to communicate somewhat to the inhabitants of those distant regions." In the execution of this design, though he was so much exposed to danger, and actually caught the plague, "that merciful Providence (as he himself piously remarks) which had hitherto preserved him, was pleased to extend his protection to him in this journey also, and to bring him home once more in safety." In his return he revisited the chief prisons and hospitals in the countries through which he passed; and afterwards went again to Scotland, and then to Ireland, where he proposed a new and very important object; namely, to inspect the Protestant Charter Schools, in some of which he had before observed shameful abuses, which he had reported to a committee of the Irish House of Commons. In this more extensive tour, he took a particular account of what he observed amiss in the conduct of this noble charity, with a view to a reformation, and not without considerable success. In the course of these journeys, particular cities and communities were not un mindful

to pay him proper respect. At Dublin, he was created by the university a Doctor of Laws; and the city of Glasgow and the town of Liverpool did honour to themselves by enrolling him among their members. Upon his return home, having again inspected the prisons in England, and the hulks on the Thames, to see what alterations had been made for the better (which he found to be very considerable, though yet imperfect), he published the result of his last laborious investigations, in "An Account of the Principal Lazarettoes in Europe, with various Papers relative to the Plague, together with further Observations on some Foreign Prisons and Hospitals, and additional Remarks on the present State of those in Great Britain and Ireland," with a great number of curious plates. The work likewise contained Observations on Penitentiary Houses, which had been encouraged by act of parliament, for the correction and reformation of criminals, of which he and Dr Fothergill had been nominated by the king to be superintendants. Beside these, he published the Grand Duke of Tuscany's "new Code of Criminal Law, with an English Translation:" and of all his publications he gave away a vast number of copies among his acquaintance in the most liberal manner. His laying open the horrors of despotism in a neighbouring country had very nearly exposed him to the sufferings of them; and had it not been for the timely notice of our ambassador, he had ended his days in the Bastille.

Not satisfied, however, with what he had already done, he concludes his "Account of Lazarettoes" with announcing his "intention again to quit his country, for the purpose of revisiting Russia, Turkey, and some other countries, and extending his tour in the east. I am not insensible (says he) of the dangers that must attend such a journey. Trusting, however, in the protection of that kind Providence which has hitherto preserved me, I calmly and cheerfully commit myself to the disposal of unerring wisdom. Should it please God to cut off my life in the prosecution of this design, let not my conduct be uncandidly imputed to rashness or enthusiasm, but to a serious deliberate conviction that I am pursuing the path of duty, and to a sincere desire of being made an instrument of more extensive usefulness to my fellow-creatures than could be expected in the narrower circle of a retired life." Accordingly, to the great concern of his friends, he set out in summer 1789 on this hazardous enterprize; the principal object of which was to administer a medicine in high repute at home, in malignant fever, † Dr Jansen's Powder. under a strong persuasion that it would be equally efficacious in the plague. In this second tour in the east, "it *did* please God to cut off his life:" for, having spent some time at Cherson, a new settlement of the empress of Russia, on the mouth of the Dnieper or Borysthenes, toward the northern extremity of the Black sea, near Oczakow, he caught, in visiting the Russian hospital of that place, or as some say a young lady who was ill of the same complaint, a malignant fever, which carried him off on the 20th of January, after an illness of about twelve days: and after having been kept, according to his express directions to his servant, five days, he was buried, by his own desire, in the garden of a villa in the neighbourhood, belonging to a French gentleman from whom he had

Howard
Howe.

received great civilities, by his faithful servant who had attended him on his former journeyings, and whom he expressly enjoined not to return home till five weeks from his death. While absent on his first tour to Turkey, &c. his character for active benevolence had so much attracted the public attention, that a subscription was set on foot to erect a statue to his honour, and in no long space above 1500l. was subscribed for that purpose. But some of those who knew Mr Howard best, never concurred in the scheme, being well assured that he would neither countenance nor accede to it; and in consequence of two letters from Mr Howard himself to the subscribers, the design was laid aside. It has, however, been resumed since his death: And surely, of all the statues or monuments ever erected by public gratitude to illustrious characters either in ancient or modern times, none was ever erected in honour of worth so genuine and admirable as his—who devoted his time, his strength, his fortune, and finally sacrificed his life, in the pursuits of humanity:—who (to adopt the expressive words of Mr Burke †) “visited all Europe [and the east], not to survey the sumptuousness of palaces, or the stateliness of temples; not to make accurate measurements of the remains of ancient grandeur, nor to form a scale of the curiosity of modern art; not to collect medals, or to collate manuscripts: but to dive into the depth of dungeons; to plunge into the infection of hospitals; to survey the mansions of sorrow and of pain; to take the gauge and dimensions of misery, depression, and contempt; to remember the forgotten; to attend to the neglected; to visit the forsaken; and to compare and collate the distresses of all men in all countries. His plan is original; and it is as full of genius as it is of humanity. It is a voyage of discovery, a circumnavigation of charity; and already the benefit of his labour is felt more or less in every country.”

HOWDEN, a town in the east riding of Yorkshire, 180 miles from London, stands on the north side of the Ouse, has a market on Saturdays, and four fairs in the year. Here was formerly a collegiate church of five prebendaries; adjacent to which the bishops of Durham, who possess many estates here with a temporal jurisdiction, have a palace. One of them built a very tall steeple to the church here, whither the inhabitants might retire in case of inundations; to which it is very liable from the great freshes that come down the Ouse sometimes at ebb. This part of the county is from hence called Howdenshire, and is watered by a conflux of several large rivers that fall into the Humber. At Howdendike is a ferry over the Ouse. Population 1812, in 1811.

HOWE, RICHARD, EARL, an English naval commander of distinguished eminence, was born in the year 1725, being the second son of Lord Viscount Howe, by the daughter of Baron Kilmansegg. From his early attachment to the life of a mariner, he quitted the school of Eton at the age of 14, and went on board the *Severn*, the honourable Captain Legge being commander, destined for the South seas under Commodore Anson. Mr Howe next appeared in the *Burford*, Captain Lushington commander, who being killed in an expedition against the *Caraccas*, Commodore Knowles made Mr Howe an acting lieutenant. At the age of 20 he was promoted to the rank of command-

er in the *Baltimore* sloop of war, and he joined a squadron at that time cruising off the coast of Scotland, where he met with an opportunity of displaying his undaunted courage and intrepidity, by engaging and beating off two French frigates of 30 guns each, by the assistance of another armed ship, notwithstanding he was severely wounded in the head during the action. This service was immediately and very justly rewarded with the rank of post-captain. He was soon after appointed to the rank of captain on board Commodore Knowles's own ship of 80 guns, with which he returned to England in the year 1748. When hostilities again commenced, he commanded the *Dunkirk* of 60 guns, in North America; which ship constituted part of the squadron under Admiral Boscawen, and with which he captured a French man of war of superior metal off the coast of Newfoundland; viz. the *Alcide* of 64 guns. In order to annoy the coast of France, he received, in the year 1758, the command of a small squadron, with which he effected the destruction, at St Malo, of a number of magazines and ships. When he served on board the *Essex*, Prince Edward, afterwards duke of York, sailed with him, at which time he powerfully contributed to the reduction of the town of Cherbourg. In 1758 his elder brother fell in North America in the service of his king and country, on which event the young commodore succeeded to the family title and estate. In the following year he participated of the honourable victory gained by Sir Edward Hawke over the French fleet under Admiral Conflans. He afterwards served in the Channel, and was captain of the *Amelia*, the ship of admiral the duke of York. On the restoration of peace, he was nominated one of the lords of the admiralty, and some time afterwards, treasurer of the navy. He was in the year 1770, raised to the rank of rear-admiral of the blue, and chosen commander-in-chief on the Mediterranean station. In 1775, he rose to the station of rear-admiral of the blue; in consequence of which rapid promotions, Lord Hawke paid him the following compliment in the house of peers: “I advised his majesty to make the promotion. I have tried my Lord Howe on important occasions; he never asked me how he was to execute any service, but always went and performed it”.

In the summer of 1776, Lord Howe appeared off Massachusetts, as commander-in-chief of his Britannic majesty's fleet acting in North America, and in the capacity of a commissioner for restoring the blessings of an amicable reconciliation. All the provincial governors were made acquainted with his arrival by means of circular letters, expressive also of the full extent of the authority invested in him and his fellow commissioners; but as congress did not deem the conditions which these letters contained to be at all satisfactory, they were ordered to be inserted in all the gazettes for the examination of the people. His powers being thus circumscribed at the very commencement, he could only act in the capacity of a naval commander, in which he aided the operations of the land forces with uncommon skill. It was not to be imagined, however, that much glory could redound to his lordship from such an unequal contest, till the junction of France with America placed the contending parties more upon a level. On the arrival of Admiral D'Estaing in the month of July 1778, off Sandy Hook, Lord Howe was certainly in a

Howe.

See Genl.
Mag. vol.
ii. p. 101.Speech at
midhall
Bristol,
&c.

Howe. very critical situation; but by an exertion of uncommon skill and dexterity, the French commander thought it prudent to retire, when he was pursued by Lord Howe to Rhode island, after he obtained a reinforcement under Admiral Byron. The intentions of the enemy were completely counteracted, and the campaign was finally terminated with honour. Here he resigned his command, and came over to England; but in 1782 he was promoted to the rank of admiral of the blue, made a viscount of Great Britain, and chosen commander of the fleet which was sent for the relief of Gibraltar. The combined fleets of France and Spain were about a third superior to that under Lord Howe, who, with 34 sail of the line, appeared off Gibraltar in the month of October, being driven into the Mediterranean by contrary winds. Although he was pursued by the combined fleet, he found means to supply the fortress with provisions. He checked the enemy by a partial action, and notwithstanding he offered to give them battle, it was declined on their part; and he had the satisfaction to execute his commission prior to his return home, in spite of the numerous difficulties which he had to encounter.

He was nominated first lord of the admiralty on the termination of the war, which he both resigned and resumed by different changes of administration. In the year 1787 he was chosen admiral of the white, and created an earl of Great Britain in the following year. When hostilities were renewed with France in 1793, his lordship accepted the command of the channel fleet, at the express desire of his Britannic majesty, but he had it not in his power to do any thing decisive till the summer of 1794. On the ever memorable 1st of June, with a fleet consisting of 25 sail of the line, he gave battle to a French fleet of 26, gaining a most signal victory over the enemy, capturing seven of their ships, one of which was so shattered as to go to the bottom, and several others were, in the language of seamen, very much crippled. His lordship had the good fortune not to lose a ship, and comparatively but a few men, considering the prodigious loss in this respect sustained by the enemy. The gratitude of the nation was suitable to the importance of this naval victory, and it is more than probable that the first of June will never be forgotten. In 1795 he was made general of marines: but the infirmities which seldom fail to be the concomitants of old age, induced him to resign his naval command in the year 1797, and on his final retreat he was presented with the honours of the Garter. His great influence as a beloved officer, contributed greatly to stifle a spirit of mutiny and discontent which at this time exhibited alarming symptoms among the seamen of his majesty's fleets. He terminated his brilliant and honourable career on the 5th of August 1799, in the 73d year of his age, leaving none but female issue behind him. His lordship's valour, always cool and steady, was consequently of that nature which enables a commander to make the most of his situation; his judgment was sound and penetrating, which prevented him from being easily imposed upon by external appearances; and his seamanship was of the most consummate and masterly kind. It is with pleasure we close this concise account of his lordship's public life by observing, that his country was deeply sensible of the value and importance of his services, a

truth fully evinced by the honours and preferments which it heaped upon him.

Howe-Island, a small island of the South sea, discovered by Captain Wallis, called by the inhabitants of the Society islands *Mopsha*; lies in S. Lat. 16. 46. and W. Long. 154. 8.

Lord Howe's Island, a small island in the neighbourhood of New South Wales, discovered on February 17th, 1788. S. Lat. 31. 36. E. Long. 159. 40. It is of an arched figure, lying from north-west to south-east, the two extremities including a space of about six miles, though, by reason of the curved figure of the island itself, it is near seven in length. It is deeply indented in the middle of the eastern part by a bay named Ross's bay, and on the opposite and western part has another named Prince William Henry's bay; so that the whole has the appearance of two islands joined together by an isthmus, which in some places is not above half a mile broad. On the southern part of that division which lies most to the northward are two considerable bays, named Callam's and Hunter's bay; and on the south-western part of the other are two high mountains, the most southerly named Mount Gower, and the other Mount Lidgbird. The convex part of the island lying towards the north-east, and the concave side towards the opposite quarter, is terminated by two points named Point King and Point Philip. No fresh water was found on the island; but it abounds with cabbage-palms, mangrove, and manchineel trees, even up to the summits of the mountains. There are plenty of gannets, and a land fowl of a dusky brown colour, with a bill about four inches long, and feet like those of a chicken. These were found to be remarkably fine meat, and were very fat. There are many large pigeons, and the white birds found in Norfolk island were also met with in this place. The bill of this bird is red, and very strong, thick, and sharp pointed. Great numbers of fine turtle frequent this island in summer, but go to the northward in winter. These, it was imagined, would prove of great service to the colony at Port Jackson; but, from some cause or other, it appears they have hitherto been disappointed. Plenty of fish were caught by a hook and line. At the distance of about four leagues from Lord Howe's island is a very remarkable and high rock, to which the name of Ball's Pyramid has been given. This island may be approached without danger; but about four miles from the south-west part of the pyramid there is a very dangerous rock, which shows itself above the surface of the water, and appears not to be larger than a boat. The southern part of the island is lined with a sandy beach, which is guarded against the sea by a reef of coral rocks, at the distance of half a mile from the beach, through which there are several small openings for boats; but there is nowhere a greater depth of water within the reef than four feet. By the account of Mr Watts, who visited this island in his return from Port Jackson, the isthmus which joins the two parts has evidently been overflowed, and the island disjoined, as in the very centre the men saw large beds of coral rocks and great quantities of shells; and on the east, which seems in general to be the weather-side, the sea has thrown up a bank of sand from 25 to 30 feet high, which serves as a barrier against future inundations. The island also appears

**Howe's
Island.**

Howe's
Island
Hoy.

pears to have suffered by volcanic eruptions, as great quantities of pumice-stones and other matters of that kind were found upon it. Mr Austin also found the whole reef which shelters the west bay a burnt-up mass. The time he visited the island was that of the incubation of the gamets, of which there were then prodigious numbers, their nests being only hollows made in the sand, there not being any quadrupeds on the island to disturb them. Besides the large pigeons already mentioned, they met with beautiful parrots and parroquets; a new species of the coote, as well as of the rail and magpie. They found likewise a very beautiful small bird of a brown colour with a yellow breast, and yellow on the wing, which seemed to be a species of humming bird. They found also a black bird like a sheerwater, having a hooked bill; and which burrows in the ground. The only insects met with here were the common earth-worm and ants: which last were in great plenty. Besides the trees already mentioned, they found several esculent vegetables, as scurvy-grass, celery, spinach, endive, and samphire.

HOWITZ, a kind of mortar, mounted upon a field-carriage like a gun. The difference between a mortar and a howitz is, that the trunnions of the first are at the end, and at the middle in the last. The invention of howitzes is of much later date than mortars, for they really had their origin from them. The constructions of howitzes are as various and uncertain as those of mortars, excepting the chambers, which are all cylindrical. They are distinguished by the diameter of the bore; for instance, a ten inch howitz is that the diameter of which is 10 inches; and so of the smaller ones.

HOWTH, a promontory which forms the northern entrance of the bay of Dublin, having a small village about seven miles north-east from that city in the province of Leinster. It gives title of earl to the family of St Lawrence, who were so called from a victory obtained by them over the Irish on St Lawrence's day 1177, their former name being Tristram; and this place has continued in possession of the family above 600 years. N. Lat. 53. 21. W. Long. 6. 22. The shores off this hill are rocky and precipitous, affording, however, a few harbours for small craft. It was formerly called Ben-hedar, i. e. "the birds promontory;" and celebrated for having Dun Criomthan, or the rath or royal palace of Criomthan erected on it, he having been chief or king of that district, and memorable for making several successful descents on the coast of Britain against the Romans in the time of Agricola. Howth, though now stript of trees, was formerly covered with venerable oaks, and was a seat of the Druids; one of their altars still remains in a sequestered valley on the east side of the hill. The mansion-house is built in form of a castle, and was probably erected by Sir Armoricus Tristram. Near the house stands the family chapel, and on the western shore are the ruins of St Mary's church, with some ancient monuments of Lord Howth's ancestors. Due west of Howth house are the ruins of St Fenton's church.

HOY, a small vessel chiefly used in coasting, or carrying goods to or from a ship, in a road or bay, where the ordinary lighters cannot be managed with safety or convenience.

It would be very difficult to describe precisely the

marks of distinction between this vessel and some others of the same size, which are also rigged in the same manner; because what is called a *hoy* in one place, would assume the name of a *sloop* or *smack* in another; and even the people who navigate these vessels, have, upon examination, very vague ideas of the marks by which they are distinguished from those above mentioned. In Holland the hoy has two masts; in England, it has but one, where the main-sail is sometimes extended by a boom, and sometimes without it. Upon the whole, it may be defined a small vessel, usually rigged as a sloop, and employed for carrying passengers and luggage from one place to another, particularly on the sea-coast.

HOY, one of the Orkney islands, which lie off the north coast of Scotland, is situated between the island of Pomona and the north coast of Caithness, and is separated from the small island of Græmeay by a sound of a mile broad. The whole island is nearly occupied by three large hills, of which that to the north-east rises from a broad base to the height of 1200 feet. Some veins of lead and iron have been discovered in this island. Birch trees of considerable size seem to have been produced on it in former times. But at present its vegetable productions, excepting what are fit for sheep pasture, are extremely limited. A few hardy alpine plants and stunted shrubs include the whole. The number of inhabitants does not exceed 520. The Dwarfie stone is the only monument of antiquity in the island. This is a large mass of sand-stone 32 feet long, 18 broad, and $7\frac{1}{4}$ feet thick above the surface. It is hollowed within, and divided into three apartments, one of which, called the *dwarf's bed*, is five feet eight long, by two feet broad. It has probably been the retreat of a hermit. Tradition says that it was the habitation of a giant. Waas or Waes, which is often considered as a distinct island, makes part of Hoy. It is distinguished for the excellence of its harbours, particularly the Longhope, one of the finest and safest in Europe. Waas contains 750 inhabitants.

HOYE, a town of Germany in Westphalia, and capital of a county of the same name. It is seated on the river Weser, and is subject to the king of Hanover. E. Long. 9. o. N. Lat. 53. 5.

HUAHEINE, one of the *SOCIETY ISLANDS*, in the South sea, situated in S. Lat. 16. 43. W. Long. 150. 52. and is about seven or eight leagues in compass. Its surface is hilly and uneven, and it has a safe and convenient harbour. It was first discovered by Captain Cook in 1769. It is divided by a deep inlet into two peninsulas connected by an isthmus, which is entirely overflowed at high water. From the appearance of its hills it may be concluded, that the country has at some period or other been the seat of a volcano. The summit of one of them had much the appearance of a crater, and a blackish spongy earth was seen upon one of its sides, which seemed to be lava; and the rocks and clay every where had a burnt appearance. The island is plentifully supplied with water by many rivulets which descend from the mountains and broken rocks. The inhabitants are nearly as fair as Europeans; and their conduct is bolder than that of the inhabitants of the other Society islands. They are a stout large-made people, some of the tallest being six feet three inches in height: they are extremely indolent, and seem to

Hoy
Huah sine.

Hudson have as little curiosity as fear. The dogs are in great favour with all their women, "who could not have caressed them (says Mr Forster) with a more ridiculous affection if they had been European ladies of fashion." Here was seen a middle-aged woman, whose breasts were full of milk, offering them to a little puppy who had been trained up to suck them. The sight disgusted those who saw it so much, that they could not forbear expressing their dislike to it; but the woman smiled, and told them that she allowed young pigs to do the same. It appeared afterwards that this woman had lost her child. Some of the gentlemen were present at a dramatic entertainment on this island: the piece represented a girl running away from her parents; and seemed to be levell'd at a female passenger who had come in Captain Cook's ship from Otaheite, and who happened to be present at the representation. It made such an impression on the girl, that the gentlemen could scarce prevail upon her to see the piece out, or to refrain from tears while it was acting. It concluded with the reception she was supposed to meet with from her friends, which was made out not to be a very agreeable one.—These people introduce extempore pieces upon occasion; and it is most probable that this was meant as a satire upon the girl above mentioned, and to discourage others from acting in the same manner.

HUBERT, Sr, a town of the Nertherlands, on the confines of Liege, with a very fine abbey, where they bring those that are bit by mad animals to be cured. E. Long. 5. 25. N. Lat. 50. 1.

HUBNER, JOHN, a learned geographer of Germany, taught geography at Leipzig and Hamburg with extraordinary reputation; and died at Hamburg in 1732, aged 63. His principal work is *A Geographical Treatise*, printed at Basil in 1746, in 6 vols. 12mo.

HUDSON, JEFFREY. See **DWARF**.

HUDSON, Henry. Of this eminent naval discoverer we know nothing prior to the year 1607, when he was employed by some London merchants in a small vessel, for exploring a north-east passage to China and Japan. He set sail on the 1st of May with only ten men and a boy, and reached as high as 80° of N. Lat. where being stopt by the ice, he returned to England in the month of September following. In his next voyage he landed at Nova Zembla, but could make no farther east, and he returned in August next year. The Dutch East India Company fitted him out in 1609, with a crew of 20 men, English and Dutch, and after in vain attempting to penetrate eastward, he steered for the American coast, and went as far as Chesapeak bay. His crew mutinying, he durst not attempt a westerly passage through Davis's strait, and therefore returned home.

His knowledge in consequence of these voyages increased his ardour for discovery, and he again made an offer of his services to the Dutch East India Company, which were not accepted; and for his last voyage, Sir Thomas Smith, Sir Dudley Digges, and some of his friends, fitted him out. On the 17th of April he set sail, and came in sight of Greenland on the 4th of June. Sailing westward, he reached the mouth of the strait which bears his name, through which he advanced along the coast of Labrador, which he called *Nova Britannia*. Here he hoped he had discovered the long-

wished-for passage; but he found he was only in a bay, in the southern part of which he determined to winter. After this he fitted out his shallop for farther discoveries, but as he had no means of revictualling his ship, he distributed his last remaining bread with tears in his eyes, among his people, and returned home. His mutinous crew entered his cabin by night, tied his hands behind his back, and set him ashore at the west end of the straits, with eight of the crew who were most attached to him. They were never more heard of, and it is probable they were swallowed up by the waves. Such was the unfortunate end of this adventurous mariner!

HUDSON, William, a celebrated English botanist, was born at Westmoreland about 1730. He was bound apprentice to an apothecary in London, whose business he took, and proved a friend to the widow and daughters. It appears from the testimony of Dr Pulteney, that he had a residence in the British museum, but we are not informed in what capacity. He was also F.R.S. and died of a paralytic distemper in May 1793. He possessed a comprehensive knowledge of English plants, which induced him to undertake an arrangement of English botany according to the Linnæan classification, a task which had been previously attempted by Dr Hill, but the execution was very imperfect. Hudson's *Flora Anglica* appeared in 1762, in one volume 8vo, the Latin preface to which was written by the ingenious Mr Stillingfleet, and received with great applause, and contributed greatly to the adoption in England of the sexual system.

The merits of Mr Hudson are thus described by Dr J. E. Smith. "His memory requires no studied eulogium here, as every page of the present work is an index to his labours. May the writer of this leave no more errors behind him as an author, or as a man." Mr Hudson well understood the insects and shells of Great Britain, and always meditated a *Fauna Britannica*. His temper is said to have been gentle, rather close, but kind to those who gained his esteem.

HUDSON'S Bay, a large bay of North America, lying between 51 and 69 degrees of latitude, discovered in 1610, by Henry Hudson. This intrepid mariner, in searching after a north-west passage to the South seas, discovered three straits, through which he hoped to find out a new way to Asia by America. He had made two voyages before on the same adventure; the first in 1607, and the second in 1608. In his third and last, 1610, he entered the straits that lead into this new mediterranean, the bay known by his name; coasted a great part of it; and penetrated to eighty degrees and a half into the heart of the frozen zone. His ardour for the discovery not being abated by the difficulties he struggled with in this empire of winter, and world of frost and snow, he staid here until the ensuing spring, and prepared in the beginning of 1611 to pursue his discoveries; but his crew, who suffered equal hardships, without the same spirit to support them, mutinied, seized upon him and seven of those who were most faithful to him, and committed them to the fury of the icy seas in an open boat. Hudson and his companions were either swallowed up by the waves, or gaining the inhospitable coast were destroyed by the savages; but the ship and the rest of the men returned home. Other attempts towards a discovery were

were made in 1612 and 1667; and a patent for planting the country, with a charter for a company, was obtained in the year 1670. In 1746 Captain Ellis wintered as far north as 57 degrees and a half, and Captain Christopher attempted farther discoveries in 1761. But besides these and the late voyages, which satisfy us that we must not look for a passage on this side of the latitude 67 degrees north, we are indebted to the Hudson's Bay company for a journey by land; which throws much additional light on this matter, by affording what may be called demonstration, how much farther north, at least in some parts of their voyage, ships must go, before they can pass from one side of America to the other. The northern Indians, who come down to the company's factories to trade, had brought to the knowledge of our people a river, which, on account of much copper being found near it, had obtained the name of the Copper-mine river. The company being desirous of examining into this matter with precision, directed Mr Hearne, a young gentleman in their service, and who having been brought up for the navy and served in it the war before last, was extremely well qualified for the purpose, to proceed over land under the convoy of these Indians, for that river, which he had orders to survey if possible quite down to its exit into the sea; to make observations for fixing the latitudes and longitudes; and to bring home maps and drawings both of it and the countries through which he should pass. Accordingly Mr Hearne set out from Prince of Wales's fort, on Churchill river, latitude $58^{\circ} 47\frac{1}{2}'$ north, and longitude $94^{\circ} 7\frac{1}{2}'$ west from Greenwich, on the 7th of December 1770. On the 13th of June he reached the Copper-mine river, and found it all the way, even to its exit into the sea, encumbered with shoals and falls, and emptying itself into it over a dry flat of the shore, the tide being then out, which seemed by the edges of the ice to rise about 12 or 14 feet. This rise, on account of the falls, will carry it but a very small way within the river's mouth, so that the water in it had not the least brackish taste. Mr Hearne was nevertheless sure of the place it emptied itself into being the sea, or a branch of it, by the quantity of whale-bone and seal skins which the Esquimaux had at their tents, and also by the number of seals which he saw upon the ice. The sea at the river's mouth was full of islands and shoals as far as he could see by the assistance of a pocket telescope; and the ice was not yet (July 17th) broken up, but thawed away only for about three quarters of a mile from the shore, and for a little way round the islands and shoals which lay off the river's mouth. But he had the most extensive view of the sea when he was about eight miles up the river; from which station the extreme parts of it bore north-west by west and north-east. By the time Mr Hearne had finished his survey of the river, which was about one o'clock in the morning on the 18th, there came on a very thick fog and drizzling rain; and as he had found the river and sea in every respect unlikely to be of any utility, he thought it unnecessary to wait for fair weather to determine the latitude more exactly by observation; but by the extraordinary care he took in observing the courses and distances, walking from Congecathawbachaga, where he had two very good observations, he thinks the latitude may be depended on with-

in 20' at the utmost. It appears from the map which Mr Hearne constructed of this singular journey, that the mouth of the Copper-mine river lies in latitude 72° north, and longitude 25° west from Churchill river; that is, about 119° west of Greenwich. Mr Hearne's journey back from the Copper-mine river to Churchill lasted till June 30th 1772: so that he was absent almost a year and seven months. The unparalleled hardships he suffered, and the essential service he performed, met with a suitable reward from his masters, and he was made governor of Prince of Wales's fort on Churchill river. The recent voyage of Captain Parry (1820) has shown that a sea does exist towards the parts where Hearne observed it, but whether this sea communicates directly with Hudson's bay remains to be discovered.

The country lying round Hudson's bay is called *New Britain*, or the country of the Esquimaux; comprehending *Labrador*, now North and South Wales. The entrance of the bay from the ocean, after leaving to the north Cape Farewell and Davis's straits, is between Resolution isles on the north, and Button's isles on the Labrador coast to the south, forming the eastern extremity of the straits distinguished by the name of its great discoverer. The coasts are very high, rocky, and rugged at top; in some places precipitous, but sometimes exhibit large beaches. The isles of Salisbury, Nottingham, and Digges, are also very lofty and naked. The depth of water in the middle of the bay is a hundred and forty fathoms. From Cape Churchill to the south end of the bay are regular soundings; near the shore shallow, with muddy or sandy bottom. To the north of Churchill the soundings are irregular, the bottom rocky, and in some parts the rocks appear above the surface at low water. From Moose river or the bottom of the bay to Cape Churchill the land is flat, marshy, and wooded with pines, birch, larch, and willows. From Cape Churchill to Wager's Water the coasts are all high and rocky to the very sea, and woodless, except the mouths of Pockerekesko and Seal rivers. The hills on their back are naked, nor are there any trees for a great distance inland.

The mouths of all the rivers are filled with shoals, except that of Churchill, in which the largest ships may lie; but ten miles higher, the channel is obstructed with land banks; and all these rivers, as far as has been navigated, are full of rapids and cataracts from ten to sixty feet perpendicular. Down these rivers the Indian traders find a quick passage; but their return is a labour of many months. As far inland as the company have settlements, which is six hundred miles to the west, at a place called Hudson House, lat. 53. long. 106. 27. from London, is a flat country: nor is it known how far to the eastward the great chain seen by our navigators from the Pacific ocean branches off.

The climate even about Hays's river, in only lat. 57. is during winter excessively cold. The snows begin to fall in October, and continue falling by intervals the whole winter; and when the frost is most rigorous, in form of the finest sand. The ice on the rivers is eight feet thick. Port-wine freezes into a solid mass; brandy coagulates. The very-breath fell on the blankets of the beds in the form of a hoar frost, and the bed-clothes often were found frozen to the wall.

Hudson's Bay.

The sun rises in the shortest day at five minutes past nine, and sets five minutes before three. In the longest day the sun rises at three, and sets about nine. The ice begins to disappear in May, and hot weather commences about the middle of June, which at times is so violent as to scorch the face of the hunters. Thunder is not frequent, but very violent. But there must be great difference of heat and cold in this vast extent, which reaches from lat. 50. 40. to lat. 63. north.—During winter the firmament is not without its beauties. Mock suns and halos are not infrequent; they are very bright, and richly tinged with all the colours of the rainbow. The sun rises and sets with a large cone of yellowish light. The night is enlivened with the Aurora Borealis, which spreads a thousand different lights and colours over the whole concave of the sky, not to be defaced even by the splendour of the full moon; and the stars are of a fiery redness.

The eastern boundary of the bay is Terra di Labrador; the northern part has a straight coast facing the bay, guarded with a line of isles innumerable. A vast bay, called the Archiwinnipy sea, lies within it, and opens into Hudson's bay by means of Gulf Hazard, through which the beluga whales dart in great numbers. Here the company had a settlement for the sake of the fishery, and for trading with the Esquimaux; but deserted it as unprofitable about the year 1758 or 1759. The eastern coast is barren past the efforts of cultivation. The surface is everywhere uneven, and covered with masses of stone of an amazing size. It is a country of fruitless valleys and frightful mountains, some of an astonishing height: the first watered by a chain of lakes, formed not from springs but rain and snow, so chilly as to be productive of only a few small trout. The mountains have here and there a blighted shrub, or a little moss. The valleys are full of crooked stunted trees, pines, fir, birch, and cedars, or rather a species of juniper. In lat. 60. on this coast, vegetation ceases. The whole shore, like that on the west, is faced with islands at some distance from land. The inhabitants among the mountains are Indians; along the coasts Esquimaux. The dogs of the former are very small; of the latter large, and headed like a fox. Notwithstanding they have rein-deer, they never train them for the sledge; but apply the dogs to that use. Walrus visit a place called Nuchvunk, in lat. 60. during winter; from thence the natives purchase the teeth with which they head their darts. Davis suspected that he had found a passage on this coast in 1586, to the Western ocean; but it proves no more than a deep bay.

The laudable zeal of the Moravian clergy induced them to send, in the year 1752, missionaries from Greenland to his country. They fixed on Nisbet's harbour for their settlement; but the first party was partly killed, partly driven away. In 1764, under the protection of our government, another attempt was made. The missionaries were well received by the Esquimaux, and the mission goes on with success.

The animals of these countries are, the moose deer, stags, rein-deer, bears, buffaloes, wolves, foxes, beavers, otters, lynxes, martins, squirrels, ermines, wild cats, and hares. The rein-deer pass in vast herds towards the north in October, seeking the extreme cold. The male polar bears rove out at sea, on the floating

ice, most of the winter, and till June: the females lie concealed in the woods, or beneath the banks of rivers till March, when they come abroad with their twin cubs, and bend their course to the sea in search of their consorts. Several are killed in their passage: and those which are wounded show vast fury, roar hideously, and bite and throw up into the air even their own progeny. The females and the young, when not interrupted, continue their way to sea. In June the males return to shore, and by August are joined by their consorts, with the cubs, by that time of a considerable size. The feathered kind are, geese, bustards, ducks, partridges, and all manner of wild-fowls. Indeed multitudes of birds retire to this remote country, to Labrador and Newfoundland, from places most remotely south, perhaps from the Antilles; and some even of the most delicate little species. Most of them, with numbers of aquatic fowls, are seen returning southward with their young broods to more favourable climates. The savages, in some respects, regulate their months by the appearance of birds; and have their goose month from the vernal appearance of geese from the south. All the grous kind, ravens, cinereous crows, titmouse, and Lapland finch, brave the severest winter; and several of the falcons and owls seek shelter in the woods. Of fish, there are whales, morses, seals, cod-fish, and a white fish preferable to herrings; and in their rivers and fresh waters, pike, perch, carp, and trout.

All the quadrupeds of these countries are clothed with a close, soft, warm fur. In summer there is here, as in other places, a variety in the colours of the several animals; when that season is over, which holds only for three months, they all assume the livery of winter, and every sort of beasts, and most of their fowls, are of the colour of the snow; every thing animate and inanimate is white. This is a surprising phenomenon. But what is yet more surprising, and what is indeed one of the most striking things, that draw the most inattentive to an admiration of the wisdom and goodness of Providence, is, that the dogs and cats from Britain that have been carried into Hudson's bay, on the approach of winter have entirely changed their appearance, and acquired a much longer, softer, and thicker coat of hair than they had originally.

Hudson's-Bay Company. See COMPANY.

Hudson's River, a large river of North America which rises on the east of Lake Ontario, and running by Albany, and on the back of the south part of New-England through part of New-York, falls into the bay of the sea beyond the west end of Long-Island, and below the town of New-York.

HUDSONIA, a genus of plants belonging to the dodecandria class. See BOTANY *Index*.

HUE and CRY, in Law, the pursuit of a person who has committed felony on the highway.—Of this custom, which is of British origin, the following deduction is given by Mr Whitaker. "When it was requisite for the Britons to call out their warriors into the field, they used a method that was particularly marked by its expeditiousness and decisiveness, and remains partially among us to this moment. They raised a cry, which was immediately caught by others, and in an instant transmitted from mouth to mouth through all the region. And, as the notice passed along

Hudson Bay
Hue and Cry.

Hue and
Cry.
Huér.

along, the warriors snatched their arms, and hurried away to the rendezvous. We have a remarkable description of the fact in Cæsar, and there see the alarm propagated in 16 or 17 hours through 160 miles in a line. And the same practice has been retained by the Highlanders to our own time. When the lord of a clan received intelligence of an enemy's approach, he immediately killed a goat with his own sword, dipped the end of a half-burnt stick in the blood, and then gave it and the notice of the rendezvous to be carried to the next hamlet. The former symbolically threatened fire and sword to all his followers that did not instantly repair to the latter. The notice was despatched from hamlet to hamlet with the utmost expedition; and in three or four hours the whole clan was in arms, and assembled at the place appointed. This was within these few years the ordinary mode by which the chieftains assembled their followers for war. The first person that received the notice, set out with it at full speed, delivered it to the next that he met, who instantly set out on the same speed, and handed it to a third. And in the rebellion of 1745, it was sent by an unknown hand through the region of Breadalbane; and flying as expeditiously as the Gallic signal in Cæsar, traversed a tract of 32 miles in three hours. This quick method of giving a diffusive alarm is even preserved among ourselves to the present day; but is applied, as it seems from Cæsar's account above to have been equally applied among the Celtæ, to the better purposes of civil polity. The *hutesium and clamour* of our laws, and the *hue and cry* of our own times, is a well-known and powerful process for spreading the notice and continuing the pursuit of any fugitive felons. The cry, like the clamour of the Gauls or the summons of the Highlanders, is taken from town to town and from county to county; and a chain of communication is speedily carried from one end of the kingdom to the other."

HUER, a name given to certain fountains in Iceland, of a most extraordinary nature; forming at times *jets d'eau*s of scalding water ninety-four feet high and thirty in diameter, creating the most magnificent gerbes that can be imagined, especially when backed by the setting sun. They arise out of cylindrical tubes of unknown depths: near the surface they expand into apertures of a funnel shape, and the mouths spread into large extent of stalactitical matter, formed of successive scaly concentric undulations. The playing of these stupendous spouts is foretold by noises roaring like the cataract of Niagara. The cylinder begins to fill: it rises gradually to the surface, and gradually increases its height, smoking amazingly, and flinging up great stones. After attaining its greatest height, it gradually sinks till it totally disappears. Boiling *jets d'eau*s and boiling springs are frequent in most parts of the island. In many parts they are applied to the culinary uses of the natives. The most capital is that which is called *Geyer*, or *Geyser*, in a plain rising into small hills, and in the midst of an amphitheatre, bounded by the most magnificent and various shaped icy mountains; among which the three-headed Hecla soars pre-eminent. See ICELAND, N^o 4. —These huers are not confined to the land; they rise in the very sea, and form scalding fountains amidst the waves. Their distance from the land is unknown;

Vol. X. Part II.

but the new volcanic isle, twelve miles off the point of Reickenes, emitting fire and smoke, proves that the subterraneous fires and waters extend to that space: for those awful effects arise from the united fury of these two elements.

HUESCA, an ancient and considerable town of Spain, in the kingdom of Arragon, with a bishop's see and a university. It is seated on the Issuela, in a soil producing excellent wine, in W. Long. o. 2. N. Lat. 42. 18.

HUESCAR, or GUESCAR, a town of Spain, in the kingdom of Granada, seated on a plain, in W. Long. 2. 20. N. Lat. 37. 32.

HUESNE, or HUENA, a small island in the Baltic sea, in the Sound, where was the famous observatory of Tycho Brahé. E. Long. 12. 38. N. Lat. 55. 54.

HUET, PETER DANIEL, a very learned French writer, born at Caen in Normandy, on the 8th of February 1630. He discovered, from his infancy, a great inclination to the study of polite literature and the sciences, and at first applied himself to the law; but Des Cartes's principles, and Bochart's sacred geography, made him change his studies for those of philosophy, mathematics, the languages, and antiquities. His admiration for Bochart made him desirous of knowing him. He contracted a very strict friendship with him, and accompanied that learned man to Sweden. Here Christina would have engaged him in her service; but he, sensible of her inconstant temper, returned to France. All he brought with him was a copy of a MS. of Origen, which he transcribed at Stockholm. He refused several offers from Christina after she abdicated and went to Rome, and from Gustavus her successor. In 1670, Mr Bossuet being appointed by the king preceptor to the dauphin, his majesty chose Mr Huet for his colleague, with the title of *sub-preceptor to the prince*. It was he that formed the plan of the commentaries *in Urum Delphini*, and directed the execution. His sentiments of piety determined him to enter into holy orders, which he did at the age of 46. Soon after this, he was presented by the king to the abbey of Aunay; and in 1685 was nominated to the bishopric of Soissons, which he changed for the see of Avranches. After governing that diocese ten years, he resigned, and was made abbot of Fontenay near Caen. His love to his native place determined him to fix there. But lawsuits coming upon him, he retired to Paris, and lodged among the Jesuits in the *Maison Professe*, whom he had made heirs to his library. A severe distemper weakened his body extremely, but not the vivacity of his genius: he wrote his own life in a very elegant style: and died in 1721, aged 91. He was a man of very agreeable conversation; and of great probity, as well as immense erudition.—The following are the titles of his principal works. 1. *De claris interpretibus, et de optimo genere interpretandi*. 2. An edition of Origen's Commentaries on the Holy Scriptures, in Greek and Latin. 3. A Treatise on the Origin of the Romans. 4. *Demonstratio evangelica*, folio. 5. *Quæstiones Alnetanæ de concordia rationis et fidei*. 6. Of the Situation of the terrestrial Paradise, in French. 7. A History of the Commerce and Navigation of the Ancients, which has been translated into English. 8. *Commentarius de rebus ad eum pertinentibus*. 9. *Huetiana*. 10. Latin and Greek verses, &c.

Huér
Huét.

HUGHLY or **HOGLY**, a town of Asia, in the kingdom of Bengal, seated on the most westerly branch of the river Ganges. It is now nearly in ruins, but was in the beginning of the 18th century a place of large extent, reaching about two miles along the river-side, and had a great trade in all the commodities of that country; affording rich cargoes for 50 or 60 ships annually, besides what was brought in carriages to the neighbouring towns. Saltpetre was brought hither from Patna in vessels above 50 yards long and five broad. The inhabitants are chiefly Indians; but there are also Portuguese, English, and other Europeans. E. Long. 88. 28. N. Lat. 32. 30.

HUGO CAPET, chief of the third race of the kings of France, being count of Paris and Orleans: he was raised to the throne for his military valour and public virtues in 987. See FRANCE, N^o 38.

HUGONIA, a genus of plants belonging to the monadelphia class; and in the natural method ranking with those of which the order is doubtful. See BOTANY Index.

HUGUENOTS, an appellation given by way of contempt to the reformed or Protestant Calvinists of France.

The name had its first rise in 1560; but authors are not agreed as to the origin and occasion thereof; but one of the two following seems to be the least forced derivation.

One of the gates of the city of Tours is called the gate Fourgon, by corruption from *feu Hugon*, i. e. the late Hugon. This Hugon was once count of Tours according to Eginhardus in his life of Charles the Great, and to some other historians. He was it seems a very wicked man, who by his fierce and cruel temper made himself dreadful; so that after his death he was supposed to walk about in the night-time, beating all those he met with: this tradition the judicious Thuanus has not scrupled to mention in his history. Davila and other historians pretend, that the nickname of *Huguenots* was first given to the French Protestants, because they used to meet in the night-time in subterraneous vaults near this gate of Hugon; and what seems to countenance this opinion is, that they were first called by the name of *Huguenots* at this city of Tours.

Others assign a more illustrious origin to that name; and say that the leaguers gave it to the reformed, because they were for keeping the crown upon the head of the line descended from Hugh Capet; whereas they were for giving it to the house of Guise, as descended from Charles the Great.

Others again derive it from a French and faulty pronunciation of the German word *edignassen*, signifying confederates, and originally applied to that valiant part of the city of Geneva, which entered into an alliance with the Swiss cantons, in order to maintain their liberties against the tyrannical attempts of Charles III. duke of Savoy.

These confederates were called *Eignots*, whence *Huguenots*.

The persecution which they underwent has scarce its parallel in the history of religion: though they obtained a peace from Henry III. in 1576, it was only of short continuance; and their sufferings, mitigated by the famous edict of Nantes, granted to them in 1598

by Henry IV. were again renewed, after the revocation of that edict, by Louis XIV. in 1685.

HULK, an old ship of war, fitted with an apparatus to fix or take out the masts of his majesty's ships, as occasion requires.

The mast of this vessel is extremely high, and withal properly strengthened by *shrouds and stays*, in order to secure what are called the *sheers*, which serve, as the arm of a crane, to hoist out or in the masts of any ship lying alongside. The sheers are composed of several long masts, whose heels rest upon the side of the hulk, and having their heads declining outward from the perpendicular so as to hang over the vessel whose masts are to be fixed or displaced. The tackles, which extend from the head of the mast to the sheer-heads, are intended to pull in the latter towards the mast-head, particularly when they are charged with the weight of a mast after it is raised out of any ship, which is performed by strong tackles depending from the sheer-heads. The effort of these tackles is produced by two capsterns, fixed on the deck for this purpose.

HULK, is also a name bestowed on any old vessel laid by as unfit for further service. It is probably derived from the *ἀλαμύς*, or vessels of burthen, of the ancient Grecians.

HULL, in the sea-language, is the main body of a ship, without either masts, yards, sails, or rigging. Thus to *strike a hull* in a storm, is to take in her sails, and to lash the helm on the lee-side of the ship; and to *hull*, or *lie a-hull*, is said of a ship whose sails are thus taken in, and helm lashed a-lee.

HULL, a river in Yorkshire, which falls into the Humber at *Kingston upon Hull*. See KINGSTON.

HUMAN, in general, is an appellation given to whatever relates to mankind: thus we say, the human soul, human body, human laws, &c.

HUMANITY, the peculiar nature of man, whereby he is distinguished from all other beings.

HUMANITIES, in the plural, signify grammar, rhetoric, and poetry, known by the name of *liberae humaniores*; for teaching of which, there are professors in the universities of Scotland, called *humanists*.

HUMBER, a river formed by the Trent, Ouse, Derwent, and several other streams. By means of inland navigation, it has a communication with the rivers Mersey, Dee, Ribble, Severn, Thames, Avon, &c. which navigation, including its windings, extends above 500 miles, in the counties of Lincoln, Nottingham, York, Lancaster, Westmoreland, Chester, Stafford, Warwick, Leicester, Oxford, Worcester. It divides Yorkshire from Lincolnshire, and falls into the German ocean near Holderness.

HUME, DAVID, Esq. a celebrated philosopher and historian, was born in the south part of Scotland on the 26th of April O. S. in the year 1711. Being the younger son of a country gentleman of good family, but no great fortune, his patrimony was of consequence insufficient to support him. For this reason he was destined for the bar, and passed through his academical courses in the university of Edinburgh; but being more inclined to studies of a different nature, he never put on the gown, nor even took the introductory steps for that purpose. The writings of Locke and Berkeley had directed the attention of the generality of learned men to-

wards metaphysics; and Mr Hume having early applied himself to studies of this kind, published in 1739 the two first volumes of his *Treatise of Human Nature*, and the third the following year. He had the mortification, however, to find his book generally decried; and to perceive, that the taste for systematic writing was now on the decline. He therefore divided this treatise into separate *Essays and Dissertations*, which he afterwards published at different times with alterations and improvements.

In 1742, Mr Hume published two small volumes, consisting of *Essays moral, political, and literary*. These were better received than his former publication; but contributed little to his reputation as an author, and still less to his profit; and his small patrimony being now almost spent, he accepted an invitation from the marquis of Anandale to come and live with him in England. With this nobleman he staid a twelvemonth; during which time his small fortune was considerably increased. He then received an invitation from General St Clair, to attend him as a secretary to his expedition, which was at first meant against Canada, but afterwards ended in an excursion against the coast of France. In 1747, he received an invitation from the general to attend him in the same station in his military embassy to the courts of Vienna and Turin. He then wore the uniform of an officer; and was introduced at these courts as aid-de-camp to the general, along with Sir Harry Erskine and Captain Grant, afterwards General Grant. In 1749, he returned to Scotland, and lived two years with his brother at his country-house; where he composed the second part of his essays, called *Political Discourses*. And now the general approbation of his performances was indicated by a more extensive sale than formerly, and likewise by the numerous answers published by different persons in order to counteract their supposed pernicious tendency. In 1752, were published at Edinburgh his *Political Discourses*, the only work of his which was well received on its first appearance; and the same year at London, his *Inquiry concerning the Principles of Morals*, which in his own opinion was incomparably the best of all his performances. This year also he was appointed librarian to the faculty of advocates at Edinburgh; the principal advantage resulting from which employment was, that he had by that means the command of a large library. He then formed the plan of writing the *History of England*: but deeming the whole to be too extensive, he confined his history to that of Britain under the house of Stuart. The book was almost universally decried on its first appearance, and soon after seemed to sink in oblivion. Dr Herring, primate of England, and Dr Stone, primate of Ireland, were the only literati of the author's acquaintance who approved of the work, and sent him messages not to be discouraged.

Notwithstanding the approbation of these eminent men, however, Mr Hume's spirits were so much sunk by his bad success, that he had some thoughts of retiring to France, changing his name, and bidding adieu to his own country for ever; but his design was rendered impracticable by the breaking out of the war of 1755 between France and Britain. He then published his *Natural History of Religion*; to which an answer was published, soon after its appearance, in the name of Dr Hurd bishop of Litchfield and Coventry; of

which, however, he since disclaimed being the sole author. In 1756, the second volume of the *History of the Stuarts* was published, two years after the appearance of the first. This was better received, and helped to retrieve the character of the former volume. Three years after, his *History of the House of Tudor* made its appearance; which was almost as ill received as the *History of the Stuarts* had been, the reign of Elizabeth being particularly obnoxious. The author, however, had now learned to despise popular clamours; and continued to finish at his leisure the more early part of the English history, which was published in 1761, and was received with tolerable success.

Mr Hume being now turned of fifty, and having obtained by the sale of his books a competent and independent fortune, retired into his native country of Scotland, determined never more to set his foot out of it. From this resolution, however, he was diverted by the earl of Hertford; whom he attended as secretary on his embassy to Paris in 1763. In 1765, the earl being appointed lord-lieutenant of Ireland, Mr Hume was intrusted with the sole management of the business of the state till the arrival of the duke of Richmond towards the latter end of the year. In 1767, he returned to Edinburgh, with a much larger income, procured to him by the earl of Hertford, than he formerly had; and now formed the same design he had formerly entertained, namely, of burying himself in his philosophical retreat. In this, however, he was again disappointed, by receiving an invitation from General Conway to be under secretary; and this invitation he was prevented from declining, both by the character of the person, and his connexions with Lord Hertford. In 1769 he returned to Edinburgh, possessed of 1000*l.* a-year, healthy, and though somewhat stricken in years, yet having a prospect of long enjoying his ease, and of seeing the increase of his reputation. Of his last illness and character, he himself gives the following account. In spring 1775, I was struck with a disorder in my bowels; which at first gave me no alarm, but has since, as I apprehend it, become mortal and incurable. I now reckon upon a speedy dissolution. I have suffered very little pain from my disorder; and what is more strange, have notwithstanding the great decline of my person, never suffered a moment's abatement of my spirits; inasmuch, that were I to name the period of my life which I should most choose to pass over again, I might be tempted to point to this latter period. I possess the same ardour as ever in study, and the same gaiety in company. I consider, besides, that a man of sixty-five, by dying, cuts off only a few years of infirmities; and though I see many symptoms of my literary reputation breaking out at last with additional lustre, I know that I could have but few years to enjoy it. It is difficult to be more detached from life than I am at present.

"To conclude, historically, with my own character, I am, or rather was (for that is the style I must now use in speaking of myself, which emboldens me the more to speak my sentiments)—I was, I say, a man of mild dispositions, of command of temper, of an open, social, and cheerful humour, capable of attachment, but little susceptible of enmity, and of great moderation

Hume
H
Humilia-
tion.

in all my passions. Even my love of literary fame, my ruling passion, never soured my temper, notwithstanding my frequent disappointments. My company was not unacceptable to the young and careless, as well as to the studious and literary; and as I took particular pleasure in the company of modest women, I had no reason to be displeas'd with the reception I met with from them. In a word, though most men anywise eminent have sound reason to complain of calumny, I never was touch'd, or even attack'd, by her baleful tooth: and though I wantonly expos'd myself to the rage of both civil and religious factions, they seem'd to be disarm'd in my behalf of their wonted fury. My friends never had occasion to vindicate any one circumstance of my character and conduct: not but that the zealots, we may well suppose, would have been glad to invent and propagate any story to my disadvantage, but they could never find any which they thought would wear the face of probability. I cannot say there is no vanity in making this funeral oration of myself, but I hope it is not a misplaced one; and this is a matter of fact which is easily clear'd and ascertain'd."

His fears concerning the incurableness of his disorder prov'd too true. He died on the 25th of August 1776; and was interred in the Calton burying-ground, Edinburgh, where a monument is erected to his memory.

HUMECTATION, form'd of humour, moisture, moistening, in pharmacy, the preparing of a medicine by steeping it a while in water, in order to soften and moisten it when too dry; or to cleanse it, or prevent its subtile parts from being dissipated in grinding, or the like.

HUMECTATION is also used for the application of moistening remedies.

In this sense we say, embrocations, emplasters, unctions, humectations, fomentations, &c.

HUMERUS, or *Os HUMERI*, in *Anatomy*, the uppermost bone of the arm, popularly call'd the *shoulder-bone*; extending from the scapula, or shoulder-blade, to the upper end of the cubitus, or elbow. See *ANATOMY Index*.

HUMIDITY, that quality in bodies whereby they are capable of wetting other bodies. This differs very much from fluidity; and seems to be merely a relative thing, depending on the congruity of the component particles of the liquor to the pores of such particular bodies as it is capable of adhering to, penetrating a little into, or wetting. Thus, for instance, quicksilver is not a moist thing with regard to our hands or clothes; but may be call'd so in reference to gold, tin, or lead, to whose surfaces it will perfectly adhere, and render them soft and moist.

HUMILIATI, a congregation of religious in the church of Rome, established by some Milanese gentlemen on their release from prison, where they had been confin'd under the emperor Conrad, or, as others say, under Frederick I. in the year 1162. This order, which acquired great wealth, and had no less than 90 monasteries, was abolish'd by Pope Pius V. in 1570, and their houses given to the Dominicans and Cordeliers, for their luxury and cruelty.

HUMILIATION, the act of humbling, i. e. of abating a person's pride, and bringing him lower in his opinion.

In this sense humiliation stands distinguish'd from mortification: humiliation brings down the mind; mortification subdues the flesh.

HUMILITY, in *Ethics*, is a virtue consisting in the moderate value which a person puts upon himself, and every thing relating to him. Or, more particularly, it consists in not attributing to ourselves any excellence or good which we have not; in not overrating any thing which we have or do; in not taking an immoderate delight in one's self; in not assuming more of the praise of a quality or action than belongs to us; and in a lowly sense and acknowledgment of our imperfections, errors, and sins. This virtue expresses itself in the modesty of our appearance, of our pursuits, and of our behaviour towards other men. It is distinguish'd from affectation, bashfulness, and meanness.

HUMMING-BIRD. See *TROCHILUS*, *ORNITHOLOGY Index*.

HUMOUR, from the Latin *humor*, in its original signification, stands for moisture in general; from whence it has been restrain'd to signify the moisture of animal bodies, or those fluids which circulate through them.

It is distinguish'd from moisture in general in this, that humours properly express the fluids of the body; when in a vitiated state, it would not be improper to say, that the fluids of such a person's body were full of humours.

The only fluids of the body, which, in their natural and healthful state, are call'd *humours*, are those in the eye; we talk of the aqueous humour, the crystalline humour, without meaning any thing that is morbid or diseas'd: yet when we say in general, that such a person has got a humour in his eye, we understand it in the usual sense of a vitiated fluid.

As the temper of the mind is supposed to depend upon the state of the fluids in the body, humour has come to be synonymous with temper and disposition. A person's humour, however, is different from his *disposition*, in this, that humour seems to be the disease of a disposition: it would be proper to say that persons of a serious temper or disposition of mind, were subject to melancholy humours; that those of a delicate and tender disposition, were subject to peevish humours.

Humour may be agreeable or disagreeable: but it is still humour; something that is whimsical, capricious, and not to be depended upon. An ill-natur'd man may have fits of good-humour, which seem to come upon him accidentally, without any regard to the common moral causes of happiness or misery.

A fit of cheerfulness constitutes the whole of good-humour; and a man who has many such fits, is a good-humour'd man: yet he may not be good-natur'd; which is a character that supposes something more constant, equable, and uniform, than what is requisite to constitute good humour.

HUMOUR is often made use of to express the quality of the imagination, which bears a considerable resemblance to wit.

Wit expresses something that is more design'd, concerted, regular, and artificial; humour, something that is more wild, loose, extravagant, and fantastical; something which comes upon a man by fits; which he can neither command nor restrain, and which is not perfectly consistent with true politeness. Humour, it has

Humilia-
tion
Humour.

Humour
Hundred.

been said, is often more diverting than wit; yet a man of wit is as much above a man of humour as a gentleman is above a buffoon; a buffoon, however, will often divert more than a gentleman. The duke of Buckingham, however, makes humour to be all in all; wit, according to him, should never be used, but to add an agreeableness to some proper and just sentiment, which, without some such turn, might pass without its effect. See WIT.

HUMPHREY, DR LAWRENCE, a very learned English divine in the 16th century, who, during the persecution under Queen Mary, retired with other Protestant refugees to Zurich. He returned on the accession of Queen Elizabeth; and was made president of Magdalene college, Oxford, dean of Gloucester, and then dean of Winchester. He was a great and general scholar, an able linguist, and a deep divine; and published, 1. *De religionis conservatione et reformatione, deque primatu regum.* 2. *De ratione interpretandi auctores.* 3. *Optimates; sive de nobilitate, ejusque origine.* 4. Sermons, and other works. He died in 1590.

HUMULUS, the HOP, a genus of plants belonging to the diccacia class; and in the natural method ranking under the 53d order, *Scabridæ*. For the culture and use of hops, see HOP.

HUNDRED, HUNDREDUM, or Centuria, a part or division of a county; which was anciently so called from its containing an hundred families, or from its furnishing an hundred able men for the king's wars. After King Alfred's dividing this kingdom into counties, and giving the government of each county to a sheriff, these counties were divided into hundreds, of which the constable was the chief officer. The grants of hundreds were at first made by the king to particular persons: but they are not now held by grant or prescription, their jurisdiction being devolved to the county-court; a few of them only excepted, that have been by privilege annexed to the crown, or granted to some great subjects, and still remain in the nature of a franchise.

HUNDRED Court. This is only a larger *Court Baron*, being held for all the inhabitants of a particular hundred instead of a manor. The free suitors are here also the judges, and the steward the register, as in the case of a court-baron. It is likewise no court of record; resembling the former in all points, except that in point of territory it is of a greater jurisdiction. This is said by Sir Edward Coke to have been derived out of the county-court for the ease of the people, that they might have justice done them at their own doors, without any charge or loss of time: but its constitution was probably coeval with that of hundreds themselves, which were formerly observed to have been introduced though not invented by ALFRED, being derived from the policy of the ancient Germans. The *centeni*, we may remember, were the principal inhabitants of a district composed of different villages, originally in number an *hundred*, but afterwards only called by that name; and who probably gave the same denomination to the district out of which they were chosen. Cæsar speaks positively of the judicial power exercised in their hundred-courts and courts-baron. "*Principes regionum, atque pagorum,*" (which we may fairly construe, the lords of hundreds and manors) *inter suos jus dicunt, controversiasque minuunt.*" And

Tacitus, who had examined their constitution still more attentively, informs us not only of the authority of the lords, but of that of the *centeni*, the hundreders, or jury; who were taken out of the common freeholders, and had themselves a share in the determination. "*Eliguntur in conciliis et principes, qui jura per pagos vicosque reddunt: centeni singulis, ex plebe comites, consilium simul et auctoritas, adsunt.*" This hundred-court was denominated *hæreda* in the Gothic constitution. But this court, as causes are equally liable to removal from hence as from the common court-baron, and by the same writs, and may also be reviewed by writ of false judgment, is therefore fallen into equal disuse with regard to the trial of actions.

HUNGARY, a kingdom of Europe, the greatest part of which was anciently called *Pannonia*. It had the name of *Hungary* from the Hunns, a Scythian or Tartar nation, who subdued it in the ninth century. It lies between the 17th and 25th degrees of east long. and betwixt the 44th and 49th degrees of north lat. being bounded to the north by the Carpathian mountains, which separate it from Poland; to the south by Servia, and the river Drave, which separates it from Slavonia; to the west by Moravia, Austria, and Stiria; and to the east by Wallachia and Transylvania. It is about 380 miles in length, and 300 in breadth; and is divided into the Upper and Lower Hungary, the former being that part which lies towards the east, and the latter that which lies towards the west.

The northern parts of the kingdom are mountainous and barren, but healthy; the southern, on the contrary, are level, and exceeding fruitful, but not very healthy. The country along the Danube, from Presburg to Belgrade, for upwards of 200 miles, is one continued plain, and no soil can be more fertile; but the air, by reason of the many swamps and morasses, is not so wholesome as on the higher and drier grounds. Here are mines of gold, silver, copper, iron, lead, quicksilver, cinnabar, antimony, yellow orpiment, sulphur, vitriol, marcasite, salt native and factitious, saltpetre, magnets, asbestos or stone-flax, marble of several colours, alabaster, with diamonds, and all sorts of precious stones. Corn is in such plenty, that it is sold for one-sixth of its price in England. Their grapes are large and luscious; and their wines preferred to any in Europe. They have vast numbers of cattle and horses, the latter mostly mouse-coloured, with buffaloes, deer, wild fowl, game, and fish, and many species of wild-beasts, particularly chamois goats, bears, and lynxes. Of vegetables, besides vines, and the common sorts, here are tobacco, saffron, buck-wheat, millet, melons, and chesnuts. Here also are excellent warm baths, and springs of various kinds and qualities. The chief mountains of Hungary are the Crapack or Carpathian, which is the general name for all those that separate this kingdom from Poland, Moravia, Silesia, and some part of Austria. The sides of most of them are covered with wood, and their tops with snow. The chief rivers are the Danube, the Drave, the Save, the Wag or Waag, the Gran, the Temes, the Raab, and Theiss, all well stocked with fish. There are several lakes among the Carpathian mountains, and some also in the lowlands.

Hundred,
Hungary.

Hungary. The inhabitants are a mixture of the descendants of the ancient Hunns, Slavonians, Camani, Germans, Wallachians, Greeks, Jews, Turks, and a wandering people called *Zigduns*, said to be of uncertain origin, but probably the same as those we called *gypsies*. The Hungarians are said to be of a sanguine choleric temper, and somewhat fierce, cruel, proud, and revengeful. They have been always reputed good soldiers, being much more inclined to arms, martial exercises, and hunting, than to arts, learning, trade, or agriculture. The nobility affect great pomp and magnificence, and are much addicted to feasting and carousing. The men in general are strong and well proportioned. They shave their beards, but leave whiskers on the upper lip; wearing fur caps on their heads, a close-bodied coat girt with a sash, with a short cloak or mantle over all, so contrived as to be buckled under the arm, and leave the right hand at liberty. Their horse are called *hussars*, and their foot *heydukes*. The former wear a broadsword or scimitar, and carry a hatchet or battle-axe. Their horses are fleet, but not near so large as the German horses, and therefore they stand up on their short stirrups when they strike. The heydukes usually wear feathers in their caps, according to the number of the enemies they pretend to have killed. Both horse and foot are an excellent militia, very good at a pursuit, or ravaging and plundering a country, but not equal to regular troops in a pitched battle. The women, when they go abroad, wear short cloaks and a veil.

There are four languages spoken in this country, viz. the Hungarian, which, like the people, is of Scythian origin, and has little or no affinity with any European tongue; the German, Slavonian, Wallachian, and Latin. The last is spoken, not only by the better sort, but also by the common people, though very corruptly. The people called *Zigduns* have also a particular jargon.—Christianity was planted in Hungary in the ninth and tenth centuries. In the sixteenth the reformation made a great progress in it; and at present the Roman Catholic religion is predominant, the Protestants enjoying only a bare toleration.

As to the traffic of this country, it is chiefly in the hands of the Greeks and Jews. The exports consist chiefly of wine, horses, cattle, metals, minerals, saffron, wool, and leather. Hungary, in particular, furnishes Austria, and other countries west of it, with vast droves of cattle, as well as a variety of excellent wines, of which those of Tokay are reckoned the best. The principal manufactures are those of copper, brass, iron, and other hard wares. Great quantities of brass and iron are exported, wrought and unwrought.

Hungary at first, like most other countries, was divided into many little principalities and states, which at length were united under one head, who had the title of *duke*. The last of these dukes was Geysa; who, becoming a proselyte to Christianity, was baptized; after which he resigned the government to his son Stephen, who took the title of *king*, anno 1000. But as the throne was filled by election, though generally out of the same family, the disposal of the crown was disputed between the Turkish and German emperors for near 200 years: but after the year 1527, when Ferdinand, archduke of Austria, was advanced to the throne, the Austrians found means to influence the elections in such a manner, as to keep the crown in

their family till 1687, when it was settled hereditarily on their heirs male; and now, in consequence of an act made by the diet at Preburg in 1723, in case of the failure of heirs-male, it is to descend to females. The states of the kingdom consist of the prelates, the barons, the gentry, and the royal towns. To the first class belong two archbishops, about a dozen bishops, near as many abbots and provosts, with the Pauline and Præmonstratensian Jesuits. To the second, the stadtholder or palatine, who represents the king; the court-judge; the ban or viceroy of Dalmatia, Croatia, and Slavonia; the stadtholder of Transylvania; the great treasurer, the great cup-bearer, the steward of the household, the master of the horse, the lord chamberlain, the captain of the yeomen of the guards, and the grand marshal of the courts, who are styled the great barons. To the third class belong the gentry, some of whom have noble manors, and others only the privileges of nobles. To the fourth class belong the royal free cities, which are not subject to the counts, but hold immediately of the king. The gentry also, who hold of the archbishops and bishops, have the same privileges as the Hungarian nobility. The common people are vassals to the lords on whose lands they live, whether these lands belong to the crown, the clergy, nobility or gentry.

Hungary contained eight millions of inhabitants in 1805, including 13,728 nobles (males only), and 162,495 clergy. Of these 4,647,832 were Catholics, 1,161,138 were of the Greek church, 1,002,490 were Calvinists or Reformed, and 624,776 were Lutherans. The Jews amounted to 72,128. The whole surface of the country amounts to 88,000 square miles, or 39,000,000 of jochs (each equal to $1\frac{1}{2}$ English acres). Of this soil only 23,900,000 acres are computed to be in cultivation or under wood. The total exports in 1802 amounted to 24,000,000 of florins, or about 2,400,000l. sterling. The imports were about 1,800,000. The revenue is reckoned to be about two millions sterling, of which only a very small portion finds its way to Vienna. The military force of Hungary has long been the chief support of the Austrian monarchy. It consists of 12 complete regiments of infantry of 3857 men each, and 10 complete hussar regiments of 1698 men each, making together 63,364 regulars. But in times of imminent danger this force is increased by a large body of irregulars. Pest, the principal town of Hungary, contained 41,882 inhabitants in 1817. See HUNGARY, SUPPLEMENT.

HUNGARY-Water, a distilled water prepared from the tops of flowers of rosemary; so denominated from a queen of Hungary, for whose use it was first made. See PHARMACY.

HUNGER, as uneasy sensation occasioned by long abstinence from food when the body is in a healthy state.—See ABSTINENCE; FASTING; and ANATOMY, N^o 103.

The following useful observations upon hunger or famine are extracted from a paper by Dr Percival in the second volume of the Manchester Transactions.

In famine, life may be protracted (the doctor observes) with less pain and misery, by a moderate allowance of water. For the acrimony and putrefaction of the humours are obviated by such dilution, the small vessels are kept permeable, and the lungs are furnished with that moisture which is es-



HUNGARY,
with
TURKEY & EUROPE.

English Miles.
0 20 40 60 80 100

16 18 Longitude East 20 from Greenwich 22 24 26 28 30

Hunger. essential to the performance of their functions. Fontana, a writer of respectable authority in the estimation of Morgagni, relates the history of a woman who obstinately refused to take any sustenance, except twice, during the space of 50 days, at the end of which period she died. But he adds, that she used water by way of drink, though in small quantity. Redi, who made many experiments (cruel and unjustifiable in my opinion), to ascertain the effects of fasting on fowls, observed, that none were able to support life beyond the ninth day to whom drink was denied; whereas one indulged with water lived more than 20 days.

Hippocrates has observed, that children are more affected by abstinence than young persons; these, more than the middle-aged; and the middle-aged, more than old men. The power to endure famine, however, must depend no less upon the state of health and strength than on the age of the sufferer. There are also particular constitutions which do not suffer much pain from the calls of hunger. Dr Percival was informed by a young physician from Geneva, that when he was a student at Montpellier, he fasted three nights and four days, with no other refreshment than a pint of water daily. His hunger was keen, but never painful, during the first and second days of his abstinence; and the two following days, he perceived only a faintness when he attempted either bodily or mental exertion: A sense of coldness was diffused over his whole frame, but more particularly affected the extremities. His mind was in a very unusual state of passivity; and he experienced a great tendency to tears whenever he recollected the circumstance which had been the occasion of his fasting. During the whole period, the alvine excretions were suppressed, but not those by the kidneys: and at the close of it, his skin became tinged with a shade of yellow. The first food he took was veal broth; which had something of an intoxicating effect, producing a glow of warmth, and raising his spirits, so as to render him ashamed of his despondency. Perhaps in the case of Sextius Bauculus, as recorded in the commentaries of Cæsar*, the extraordinary courage and prowess which he suddenly exerted, might be aided by the exhilarating effect of sustenance, which, under such circumstances, it is probable he would no longer decline. The fact, however, evinces, that neither his sickness nor the sensations of hunger had been so violent as much to impair his strength of body or vigour of mind. Pomponius Atticus, the celebrated friend of Cicero, who put a voluntary end to his life in the 77th year of his age by refusing all food, appears to have experienced ease from his disorder, rather than any acute sufferings by famine. "Sic cum bibeo cibo se abstinisset, subito febris decessit, leviorque morbus esse coepit: tamen propositum nihil secius perigit. Itaque die quinto, postquam id consilium inerat, decessit." (*Corn. Nepos in Vit. Pomp. Attic.*) From the former circumstance it has been conjectured, that he did not wholly deny himself the use of water, or of some other diluent. But though a few examples of this kind may be adduced, we have the evidence of numerous melancholy facts to show, that the pressure of want is agonizing to the human frame. "I have talked (says an ingenious writer †) with a captain of a ship, who was one of six that endured it in its extremity, and who was the only person that had not lost his senses when

they received accidental relief. He assured me his pains at first were so great, as to be often tempted to eat a part of one of the men who died, and which the rest of his crew actually for some time lived upon. He said, that during the continuance of this paroxysm, he found his pains insupportable, and was desirous at one time of anticipating that death which he thought inevitable: But his pains, he said, gradually decreased after the sixth day (for they had water in the ship, which kept them alive so long), and then he was in a state rather of languor than desire; nor did he much wish for food, except when he saw others eating; and that for a while revived his appetite, though with diminished importunity. The latter part of the time, when his health was almost destroyed, a thousand strange images rose upon his mind; and every one of his senses began to bring him wrong information. The most fragrant perfumes appeared to him to have a fetid smell; and every thing he looked at took a greenish hue, and sometimes a yellow. When he was presented with food by the ship's company that took him and his men up, four of whom died shortly after, he could not help looking upon it with loathing instead of desire; and it was not till after four days that his stomach was brought to its natural tone; when the violence of his appetite returned with a sort of canine eagerness."

To those who by their occupations are exposed to such dreadful calamities, it is of serious importance to be instructed in the means of alleviating them. The American Indians are said to use a composition of the juice of tobacco, and the shells of snails, cockles, and oysters calcined, whenever they undertake a long journey, and are likely to be destitute of provisions. It is probable the shells are not burnt into quicklime, but only so as to destroy their tenacity, and to render them fit for levigation. The mass is dried, and formed into pills, of a proper size to be held between the gum and lip, which, being gradually dissolved and swallowed, obtund the sensations both of hunger and of thirst. Tobacco, by its narcotic quality, seems well adapted to counteract the uneasy impressions which the gastric juice makes on the nerves of the stomach when it is empty; and the combination of testaceous powder with it may tend to correct the secretion that is supposed to be the chief agent in digestion, and which, if not acid, is always united with acidity. Certain at least it is, that their operation is both grateful and salutary; for we find the luxurious inhabitants of the East Indies mix them with the betel nut, to the chewing of which they are universally and immoderately addicted. Perhaps such absorbents may be usefully applied, both to divide the doses and to moderate the virulence of the tobacco. For, in the internal exhibition of this plant, much caution is required, as it produces sickness, vertigo, cold clammy sweats, and a train of other formidable symptoms, when taken in too large a quantity. During the time of war, the impressed sailors frequently bring on these maladies, that they may be admitted into the hospitals, and released from servitude. It would be an easy and safe experiment to ascertain the efficacy, and to adjust the ingredients, of the Indian composition mentioned. And there is reason to believe, that the trial would be in some degree successful; for it is known that smoking tobacco

* Lib. vi.

† Dr Goldsmith's *Hist. of the Earth*, vol. ii. 126.

Hauger.

tobacco gives relief to those habitual pains of the stomach which appear to arise from the irritation of the gastric secretion. The like effect is sometimes produced by increasing the flow of saliva, and swallowing what is thus discharged. And Dr Percival has related the case of a gentleman, who used to masticate, many hours daily, a piece of lead, which being neither hard, friable, nor offensive to the palate, suited his purpose, as he thought, better than any other substance. He continued the custom many years, deriving great ease from it, and suffering no sensible injury from the poisonous quality of the metal. On mentioning this fact to a navy surgeon, the doctor was told, that the sailors, when in hot climates, are wont to mitigate thirst by rolling a bullet in their mouths. A more innocent mean, the doctor observes, might be devised; but the efficacy of this evinces, that the salivary glands are for a while capable of furnishing a substitute for drink. When a scarcity of water occurs at sea, Dr Franklin has advised, that the mariners should bathe themselves in tubs of salt-water: For, in pursuing the amusement of swimming, he observed, that, however thirsty he was before immersion, he never continued so afterwards; and that, though he soaked himself several hours in the day, and several days successively, in salt-water, he perceived not, in consequence of it, the least taste of saltness in his mouth. He also further suggests, that the same good effect might perhaps be derived from dipping the sailor's apparel in the sea; and expresses a confidence that no danger of catching cold would ensue.

To prevent the calamity of famine, at sea, it has been proposed by Dr Lind, that the powder of salep should constitute part of the provisions of every ship's company. This powder and portable soup, dissolved in boiling water, form a rich thick jelly; and an ounce of each of these articles furnishes one day's subsistence to a healthy full grown man. Indeed, from Dr Percival's experiments it appears, that salep contains more nutritious matter, in proportion to its bulk, than any other vegetable production now used as food. It has the property also of concealing the nauseous taste of salt-water; and consequently may be of great advantage at sea, when the stock of fresh water is so far consumed, that the mariners are put upon short allowance. By the same mucilaginous quality, it covers the offensiveness, and even in some measure, corrects the acrimony, of salted and putrescent meats. But, as a preservative against hunger, salep would be most efficacious combined with an equal weight of beef suet. By swallowing little balls of this lubricating compound at proper intervals, the coats of the stomach would be defended from irritation: and as oils and mucilages are highly nutritive, of slow digestion, and indisposed to pass off by perspiration, they are peculiarly well adapted to support life in small quantities. This composition is superior in simplicity, and perhaps equal in efficacy, to the following one, so much extolled by Avicenna the celebrated Arabian physician; to whom we are indebted for the introduction of rhubarb, cassia, tamarinde, and senna, into the materia medica. "Take sweet almonds and beef suet, of each one pound; of the oil of violets two ounces; and of the roots of marsh-mallows one ounce: bray these ingredients together in a mortar, and form the mass into boluses, about the size

of a common nut." Animal fat is singularly powerful in assuaging the most acute sensations of thirst, as appears from the narrative of the sufferings experienced by those who were confined in the black hole at Calcutta. A hundred and forty-six persons, exhausted by fatigue and military duty, were there thrust together into a chamber of 18 cubic feet, having only two windows, strongly barred with iron, from which, in a close sultry night, and in such a climate as that of Bengal, little or no circulation of fresh air could be enjoyed. In a few minutes, these unhappy wretches fell into so profuse a perspiration, that an idea can hardly be formed of it; and this was succeeded by a raging thirst, which increased in proportion as the body was drained of its moisture. Water! Water! became the universal cry; and an old soldier on the outside, through pity, furnished them with a few skinfuls of it. But these scanty supplies, like sprinklings on the fire, served only to feed and increase the flame. From this experience of its effects, Mr Holwell, their chief, determined to drink no more; and kept his mouth moist by sucking the perspiration out of his shirt sleeves, and catching the drops as they fell from his head and face. "You cannot imagine (says he) how unhappy I was if any of them escaped me." He came into the prison without his coat, the season being too hot to bear it; and one of his miserable companions, observing the expedient he had hit upon of allaying his thirst, robbed him from time to time of a considerable part of his store. This plunderer, whom he found to be a young gentleman in the service of the East India Company, afterwards acknowledged, that he owed his life to the many comfortable draughts which he derived from him. Before Mr Holwell adopted this mode of relief, he had attempted, in an ungovernable fit of thirst, to drink his own urine: but it was so intensely bitter, that a second taste could not be endured; whereas, he assures us, no Bristol water could be more soft and pleasant than his perspiration. And this, we may presume, consisted chiefly of animal fat, melted by excessive heat, and exuding from the cellular membrane through the pores of the skin.

Persons who have been accustomed to animal food, are soon reduced when supplied only with the farinae. Several years ago, to determine the comparative nutritive powers of different substances, an ingenious young physician, as Dr Percival informs us, made a variety of experiments on himself, to which he unfortunately fell a sacrifice. He lived a month upon bread and water; and under this regimen of diet he every day diminished much in his weight. But in 1784, a student of physic at Edinburgh confined himself for a longer space of time to a pint of milk and half a pound of white bread daily: And he assured our author, that he passed through the usual labours of study and exercise without feeling any decay of health or strength, and without any sensible loss of bulk. The cutaneous, urinary, and alvine excretions, were very scanty during the whole period; and the discharge of faeces occurred only once in a week. In this case the oily and coagulable parts of the milk probably furnished a larger proportion of aliment, and at the same time contributed to check the waste by perspiration and other discharges; for oleaginous substances are retained long in the body by their viscosity. Dr

Hauger.

Hunger. Russel, in his Natural History of Aleppo, relates, that in those seasons when oil abounds, the inhabitants, by indulgence in it, are disposed to fever, and affected with infarctions of the lungs; maladies which indicate both retention and obstruction. Milk has been suspected by some of producing similar effects, though in a slighter degree; and the free use of it has been on this account forbidden to asthmatics.

Gum arabic might be a good substitute for salep in the composition already recommended; and as it will give such firmness to the mass, as to require manducation, the saliva, by this means separated and carried into the stomach, would further contribute to assuage the sensations both of hunger and of thirst. See *Gum-Arabic*. This gum, combined with sugar and the whites of eggs, has been lately extolled in France, under the name of *patigumo*, as a remedy for catarrhal defluxions. Dr Percival has seen cakes made of these ingredients, and thinks they might very well be applied to the purpose of obviating hunger. They are not perishable in the hottest climates, may be carried about the person with convenience, and though very tough are pleasant to the taste. In the formula by which they are made, the proportion of sugar is too large, and that of gum arabic too small, if the mass be intended to assuage the cravings of appetite. According to our author's information, the receipt is as follows. "Take of fine sugar four ounces, and of gum-arabic one ounce: Levigate them well together; and add half an ounce of rose water, and of the white of eggs a sufficient quantity."

In our attempts to recover those who have suffered under the calamities of famine, great circumspection is required. Warmth, cordials, and food, are the means to be employed; and it is evident that these may prove too powerful in their operation, if not administered with caution and judgment. For the body, by long fasting, is reduced to a state of more than infantile debility; the minuter vessels of the brain, and of the other organs, collapse for want of fluids to distend them; the stomach and intestines shrink in their capacity; and the heart languidly vibrates, having scarcely sufficient energy to propel the scanty current of blood. Under such circumstances, a proper application of heat seems an essential measure, and may be effected by placing on each side a healthy man in contact with the patient. Pedituvia or fomentations may also be used with advantage. The temperature of these should be lower than that of the human body, and gradually increased according to the effects of their stimulus. New milk, weak broth, or water gruel, ought to be employed both for the one and the other; as nutriment may be conveyed into the system this way, by passages probably the most pervious in a state of fasting, if not too long protracted. "A lad at Newmarket †, a few years ago, having been almost starved in order that he might be reduced to a proper weight for riding a match, was weighed at nine o'clock in the morning, and again at ten; and he was found to have gained near 30 ounces in weight in the course of an hour, though he had only drank half a glass of wine in the interval. The wine probably stimulated the action of the nervous system, and incited nature, exhausted by abstinence, to open the absorbent pores of the whole body, in order to suck in some nourishment from the air." But no such ab-

VOL. X. Part II. †

sorption as this can be expected in a state of extreme weakness and emaciation gradually induced; because the lymphatics must partake of the general want of tone and energy. And notwithstanding the salutary effects of wine in the case of the jockey, who, it is likely, had been reduced by sweating as well as by abstinence, such a stimulant might prove dangerous, and even fatal in other cases. It appears safer therefore to advise the exhibition of cordials in very small doses, and at first considerably diluted. Slender wine-woy will perhaps best answer this purpose; and afford, at the same time, an easy and pleasant nourishment. When the stomach has been a little strengthened, an egg may be mixed with the whey, or administered under some other agreeable form. The yolk of one was, to Cornaro, sufficient for a meal; and the narrative of this noble Venetian, in whom a fever was excited by the addition of only two ounces of food to his daily allowance, shows, that the return to a full diet should be conducted with great caution, and by very slow gradations.

HUNGERFORD, a town of Berkshire in England, seated on the river Kennet, in a low and watery soil. It is a great thoroughfare in the Bath and Bristol road, sixty-five miles from London; and was formerly called *Ingleford-Charnamstreet*. The constable of this town, who is chosen annually, is lord of the manor, which he holds immediately of the crown. They have a horn here which holds about a quart, and appears by an inscription on it to have been given by John of Gaunt, together with a grant of the royal fishery, in a part of the river which abounds with good trouts and craw-fish. Here is a market on Wednesdays, and fair in August. Population 1957.

HUNNINGUEN, a town of Alsace, subject to the French; seated on the Rhine, and fortified by Vauban. Its fortifications were demolished since 1816. E. Long. 11. 40. N. Lat. 47. 42.

HUNNS, a fierce and savage nation, who formerly inhabited that part of Sarmatia bordering on the Palus Mæotis and the Tanais, the ancient boundary between Europe and Asia. Their country, as described by Procopius, lay north of Mount Caucasus, which, extending from the Euxine to the Caspian seas, parts Asiatic Sarmatia from Colchis, Iberia, and Albania; lying on the isthmus between the two seas above mentioned. Here they resided unknown to other nations, and themselves ignorant of other countries, till the year 376. At this time, a hind pursued by the hunters, or, according to some authors, an ox stung by a gad-fly, having passed the marsh, was followed by some Hunns to the other side, where they discovered a country much more agreeable than their own. On their return, having acquainted their countrymen with what they had seen, the whole nation passed the marsh, and falling upon the Alans, who dwelt on the banks of the Tanais, almost exterminated them. They next fell upon the Ostrogoths, whom they drove out of their country, and forced to retire to the plains between the Borysthenes and the Tanais, now known by the name of *Podolia*. Then attacking the Visigoths, they obliged them to shelter themselves in the most mountainous parts of their country; till at last the Gothic nations finding it impossible to withstand such an inundation of barbarians, obtained leave from the emperor Valens to settle in Thrace.

Hunns.

The Hunns thus became masters of all the country between the Tanais and Danube in 376, where they continued quietly till the year 388, when great numbers of them were taken into the pay of Theodosius I. but, in the mean time, a party of them, called the *Nepthalite* or *White Hunns*, who had continued in Asia, overran all Mesopotamia, and even laid siege to Edessa, where they were repulsed with great slaughter by the Romans. The European Hunns frequently passed the Danube, committing the greatest ravages in the western empire; sometimes they fell upon the eastern provinces, where they put all to fire and sword. They were often defeated and repulsed by the Romans, but the empire was now too weak to subdue or confine them from making excursions; so that they continued to make daily encroachments, and became every day more formidable than before. In 411, the Hunns, under Attila, threatened the western empire with total destruction. This monarch, having made himself master of all the northern countries from the confines of Persia to the banks of the Rhine, invaded Mæssia, Thrace, and Illyricum; where he made such progress, that the emperor not thinking himself safe in Constantinople, withdrew into Asia. Attila then broke into Gaul; where he took and destroyed several cities, massacring the inhabitants with the greatest cruelty. At last he was driven out with great slaughter by Aetius the Roman general, and Theodoric king of the Goths, and could never afterwards make any great progress. About the year 452 or 453 Attila died, and his kingdom was immediately split into a number of small ones by his numerous children, who waged perpetual war with each other. The Hunns then ceased to be formidable, and became daily less able to cope with the other barbarous nations whom Attila had kept in subjection. Still, however, their dominion was considerable; and in the time of Charles the Great they were masters of Transylvania, Wallachia, Servia, Carniola, Carinthia, and the greater part of Austria, together with Bosnia, Selavonia, and that part of Hungary which lies beyond the Danube. In the year 776, while Charles was in Saxony, two princes of the Hunns, Caganus and Jugonus, sent ambassadors to him, desiring his friendship and alliance. Charles received them with extraordinary marks of friendship, and readily complied with their request. However, they entered, not long after, into an alliance with Tassila duke of Bavaria, who had revolted from Charles, and raised great disturbances in Germany. Charles dissembled his resentment till he had entirely reduced Bavaria, when he resolved to revenge himself on the Hunns for those succours they had underhand given to his enemy. Accordingly, he ordered levies to be made throughout his dominions; and having by that means assembled a very numerous army, he divided it into two bodies, one of which he commanded himself, and the other he committed to the care of his generals. The two armies entered the kingdom of the Hunns at different places, ravaged their country far and near, burnt their villages, and took all their strong holds. This he continued for eight years, till the people were almost totally extirpated; nor did the Hunns ever afterwards recover themselves, or appear as a distinct nation.

There were two different nations that went by the name of *Hunns*; the *Nepthalite* or *White Hunns*, and

the Sarmatian or Scythian Hunns. The former inhabited a rich country, bordering to the north on Persia, and at a great distance from the Sarmatian or Scythian Hunns, with whom they had no intercourse, nor the least resemblance either in their persons or manners. They were a powerful nation, and often served against the Romans in the Persian armies; but in the reign of the emperor Zeno, being provoked by Perozes king of Persia laying claim to part of their country, they defeated the Persians in two pitched battles, slew their king, overran all Persia, and held it in subjection for the space of two years, obliging Cabades, the son and successor of Perozes, to pay them a yearly tribute. These Hunns, called by the writers of those times the *white Hunns*, did not wander, like the others, from place to place; but, contented with their own country, which supplied them with all necessaries, they lived under a regular government, subject to one prince, and seldom made inroads, unless provoked, either into the Persian or Roman territories. They lived according to their own laws, and dealt uprightly with one another, as well as with the neighbouring people. Each of their great men used to choose twenty or more companions to enjoy with him his wealth, and partake of all his diversions; but, upon his decease, they were all buried with him in the same grave. This custom savours of barbarity; but in every other respect, the *Nepthalite* were a far more civilized nation than the *Scythian Hunns*, who, breaking into the empire, filled most of the provinces of Europe with blood and slaughter.

The latter were, according to Ammianus Marcellinus, a savage people, exceeding in cruelty the most barbarous nations. They began to practise their cruelty, says Jornandes, upon their own children the very first day they come into the world, cutting and mangling the cheeks of their males, to prevent the growth of hair which they must have looked upon, contrary to the sentiments of other nations, as unbecoming and unmanly. They had, perhaps, in this practice another view, which Jornandes seems to insinuate elsewhere, viz. to strike terror into the enemy with their countenances, thus deformed and covered with scars. They had no other food but roots and raw meat, being quite unacquainted with the use of fire, and no houses at all, not even huts; but lived constantly exposed to the air in the woods, and on the mountains, where, from their infancy, they were inured to hunger, thirst, and all manner of hardships: nay, they had such an aversion to houses, which they called the *sepulchres of the living*, that, when they went into other countries, they could hardly be prevailed upon to come within the walls of any house, not thinking themselves safe when shut up and covered. They used even to eat and sleep on horseback, scarce ever dismounting; which, in all likelihood, induced Zosimus to write, that the Hunns could not walk. They covered their nakedness with goats skins, or the skins of a sort of mice sewed together. Day and night were indifferent to them, as to buying, selling, eating, and drinking. They had no law, nor any kind of religion; but complied with their inclinations, whatever they prompted them to, without the least restraint, or distinction between good and evil. In war, they began the battle with great fury, and a hideous noise: but if they met with a vigorous opposition, their

Hunns.

Hunas.
Hunter.

their fury began to abate after the first onset; and when once put into disorder, they never rallied, but fled in the utmost confusion. They were quite unacquainted with the art of besieging towns; and authors observe, that they never attacked the enemy's camp. They were a faithless nation, and thought themselves no longer bound by the most solemn treaties, than they found their advantage in observing them. Hence we often find them, upon the least prospect of obtaining more advantageous conditions, breaking into the Roman empire, in defiance of the most solemn pacts and engagements. Several corps of Hunas, after their coming into Europe, served in the Roman armies against the Goths and other barbarous nations; nay, they were ready, for hire, to fight against each other, being blind to every other regard and consideration.

HUNTER, a name given to a horse qualified to carry a person in the chase. The shape of the horse designed for this service, should be strong and well knit together, as the jockeys express it. Irregular or unequal shapes in these creatures are always a token of weakness. The inequalities in shape which show a horse improper for the chase, are the having a large head and a small neck, a large leg and a small foot, and the like. The head of the hunter should indeed always be large, but the neck should also be thick and strong to support it. The head should be lean, the nostrils wide, and the windpipe straight.

The hunter, in order to his behaving well in the field, ought to have great care and indulgence in the stable: he ought to have as much rest and quiet as may be, to be kept well supplied with good meat, clean litter, and fresh water by him; he should be often dressed, and suffered to sleep as much as he pleases. He should be so fed, that his dung may be rather soft than hard, and it must be of a bright and clean colour. All this may be easily managed by the continual observance and change of his food, as occasion requires. After his usual scourings he should have exercises and mashes of sweet malt, or bread and beans; or wheat and beans mixed together, are to be his best food, and beans and oats his worst.

Some very great sportsmen are for keeping their horses out at grass all the buck-hunting season, never taking them up into the stable at all, but allowing them in the field as much oats with their grass as they will eat. The horse may be thus rid three days in the week for the whole season, and never damaged by it, nor ever showing any marks of harm afterwards.

The whole shape of a horse intended for a hunter, should be this: The ears should be small, open, and pricked; or though they be somewhat long, yet if they stand up erect and bold like those of a fox, it is a sign of toughness or hardiness. The forehead should be long and broad, not flat, or, as it is usually termed, *mar-faced*, but rising in the middle like that of a hare; the feather should be placed above the eye, the contrary being thought by some to threaten blindness. The eyes should be full, large, and bright; the nostrils not only large, but looking red and fresh within; for an open and fresh nostril is always esteemed a sign of a good wind. The mouth should be large, deep in the wicks, and hairy. The windpipe should be large, and appear straight when he biddles his head; for if, on the contrary, it bends like a bow on his bridling, it is not

formed for a free passage of the breath. This defect in a horse is expressed among the dealers by the phrase *cock-thropped*. The head should be so set on to the neck, that a space may be felt between the neck and the chine; when there is no such space, the horse is said to be bull-necked; and this is not only a blemish in the beauty of the horse, but it also occasions his wind not to be so good. The crest should be strong, firm, and well risen; the neck should be straight and firm, not loose and pliant; the breast should be strong and broad, the ribs round like a barrel, the fillets large, the buttocks rather oval than broad, the legs clean, flat, and straight; and, finally, the mane and tail ought to be long and thin, not short and bushy, the last being counted a mark of dulness. When a hunter is thus chosen, and has been taught such obedience, that he will readily answer to the rider's signals both of the bridle and hand, the voice, the calf of the leg, and the spurs; that he knows how to make his way forward, and has gained a true temper of mouth, and a right placing of his head, and has learned to stop and to turn readily, if his age be sufficiently advanced, he is ready for the field. It is a rule with all staunch sportsmen, that no horse should be used in hunting till he is full five years old; some will hunt them at four, but the horse at this time is not come up to his true strength and courage, and will not only fail at every tough trial, but will be subject to strains and accidents of that kind, much more than if he were to be kept another year first, when his strength would be more confirmed.

When the hunter is five years old, he may be put to grass from the middle of May till Bartholomew-tide; for the weather between these is so hot, that it will be very proper to spare him from work. At Bartholomew-tide, the strength of the grass beginning to be nipped by frosts and cold dews, so that it is apt to engender crudities in the horse, he should be taken up while his coat is yet smooth and sleek, and put into the stable. When he is first brought home, he should be put in some secure and spacious place, where he may evacuate his body by degrees, and be brought not all at once to the warm keeping; the next night he may be stabled up. It is a general rule with many not to clothe and stable up their horses till two or three days after they are taken from grass, and others who put them in the stable after the first night, yet will not dress and clothe them till three or four days afterward; but all this, except the keeping the horse one day in a large and cool place, is needless caution.

There is a general practice among the grooms, in many places, of giving their hunters wheat-straw as soon as they take them up from grass. They say they do this to take up their bellies; but there seems much reason to disapprove of this. The change is very violent, and the nature of the straw so heating and drying, that there seems great reason to fear that the astringent nature of it would be prejudicial, more than is at first perceived. It is always found that the dung is hard after this food, and is voided with pain and difficulty, which is in general very wrong for this sort of horse. It is better therefore to avoid this straw-feeding, and to depend upon moderate airing, warm clothing, and good old hay and old corn, than to have recourse to any thing of this kind.

Hunter.

Hunter.

When the horse has evacuated all his grass, and has been properly shod, and the shoes have had time to settle to his feet, he may be ridden abroad, and treated in this manner: the groom ought to visit him early in the morning, at five o'clock in the long days, and at six in the short ones; he must then clean out the stable, and feel the horse's neck, flank, and belly, to find the state of his health. If the flank feels soft and flabby, there is a necessity of good diet to harden it, otherwise any great exercise will occasion swellings and goutiness in the heels. After this examination, a handful or two of good old oats, well sifted, should be given him; this will make him have more inclination to water, and will also make the water sit better on his stomach, than if he drank fasting. After this, he is to be tied up and dressed. If in the doing of this he opens his mouth, as if he would bite, or attempts to kick at the person, it is a proof that the teeth of the currycomb are too sharp, and must be filed blunter. If after this he continues the same tricks, it is through wantonness, and he should be corrected for it with the whip. The intent of currying being only to raise the dust, this is to be brushed off afterwards with a horse-tail nailed to a handle, or any other light brush. Then he is to be rubbed down with the brush, and dusted a second time; he should then be rubbed over with a wet hand, and all the loose hairs, and whatever foulness there is, should be picked off. When this is done, and he is wiped dry as at first, a large saddle-cloth is to be put on, reaching down to the spurring place; then the saddle is to be put on, and a cloth thrown over it that he may not take cold: then rub down his legs, and pick his feet with an iron picket, and let the mane and tail be combed with a wet mancomb. Lastly, it is a custom to spurt some beer in his mouth just before the leading him out of the stable. He should then be mounted, and walked a mile at least to some running water, and there watered; but he must only be suffered to take about half his water at one drinking.

It is the custom of many to gallop the horse at a violent rate as soon as he comes out of the water; but this is extremely wrong for many reasons. It endangers the breaking a horse's wind more than any other practice, and often has been the occasion of bursting very good horses. It uses them also to the disagreeable trick we find in many horses, of running away as soon as ever they come out of the water: and with some it makes them averse to drinking, so that they will rather endure thirst, and hurt themselves greatly by it, than bring on the violent exercise which they remember always follows it. The better way is to walk him a little after he is out of the water, then put him to a gentle gallop for a little while, and after this to bring him to the water again. This should be done three or four times, till he will not drink any more. If there is a hilly place near the watering place, it is always well to ride up to it: if otherwise, any place is to be chosen where there is free air and sun. That the creature may enjoy the benefit of this, he is not to be galloped, but walked about in this place an hour, and then taken home to the stable. The pleasure the horse himself takes in these airings when well managed is very evident; for he will gape, yawn, and shrug up his body: and in these, whenever he would stand still to stale,

or listen to any noise, he is not to be hindered from it, but encouraged in every thing of this kind. Hunter.

The advantages of these airings are very evident; they purify the blood, teach the creature how to make his breathing agree with the rest of the motions of his body, and give him an appetite to his food, which hunters and racers that are kept stalled up are otherwise very apt to lose. On returning from airing, the litter of the stable should be fresh, and by stirring this and whistling, he will be brought to stale. Then he is to be led to his stall, and tied up, and again carefully rubbed down; then he should be covered with a linen cloth next his body, and a canvas one over that, made to fit him, and reaching down to his legs. This, as the duke of Newcastle observes, is a custom which we learned of the Turks, who are of all people the most nice and careful of their horses. Over this covering there should be put a body-cloth of six or eight straps; this keeps his belly in shape, and does not hurt him. This clothing will be sufficient while the weather is not very sharp; but in severe seasons, when the hair begins to rise and start in the uncovered part, a woollen cloth is to be added, and this will always prove fully sufficient.

Different horses, and different seasons, make variety of the degree of clothing necessary; but there always is an obvious rule to point out the necessary changes, the roughness of the coat being a mark of the want of clothing, and the smoothness of it a proof that the clothing is sufficient. Therefore if at any time the hair is found to start, it is a notice that some farther clothing is to be added.

If the horse sweat much in the night, it is a sign that he is over fed and wants exercise: this therefore is easily remedied. An hour or more after the horse is come in from his airing, the groom should give him a wisp of clean hay, making him eat it out of his hand; after this let the manger be well cleaned out, and a quarter of oats clean sifted be given him. If he eats up this with an appetite, he should have more given him; but if he is slow and indifferent about it, he must have no more. The business is to give him enough, but not to cloy him with food.

If the horse gets flesh too fast on this home feeding, he is not to be stinted to prevent it, but only his exercise increased; this will take down his flesh, and at the same time give him strength and wind. After the feeding in the morning is over the stable is to be shut up, only leaving him a little hay on his litter. He need be no more looked at till one o'clock, and then only rubbed down, and left again to the time of his evening watering, which is four o'clock in the summer and three in the winter. When he has been watered, he must be kept out an hour or two, or more if necessary, and then taken home and rubbed as after the morning watering. Then he is to have a feed of corn at six o'clock, and another at nine at night; and being then cleaned, and his litter put in order, and hay enough left for the night, he is to be left till morning. This is the direction for one day, and in this manner he is to be treated every day for a fortnight; at the end of which time his flesh will be so hardened, his wind so improved, and his mouth so quickened, and his gallop brought to so good a stroke, that he will be fit to be put to moderate hunting. During the time that he is

Hunter. used to hunting, he must be ordered on his days of rest exactly as is directed for the fortnight when he is in preparation; but as his exercise is now greatly increased, he must be allowed a more strengthening food, mixing some old split beans at every feeding with his oats.

And if this is not found to be sufficient, the following bread must be given: let two pecks of old beans and one peck of wheat be ground together, and made into an indifferently fine meal; then knead it into dough with some warm water, and a good quantity of yeast; let it lie a time that it may rise and swell, which will make the bread lighter; then make it into loaves of a peck each, and let it be baked in a slow oven, that it may be thoroughly done without being burnt; when it is taken out of the oven, it must be set bottom upwards to cool; when it is one day old the crust is to be chipped off, and the crumb given him for food. When this is ready, he should have some of it at least once in the day: but it is not to be made the only food, but some feeds are to be of oats alone, some of oats and this bread, and some of oats and beans mixed together. The making a variety in this manner being the best of all methods for keeping up the appetite, which is often apt to fail.

The day before the horse is to hunt, he must have no beans, because they are hard of digestion, but only some oats with this bread: or if he will be brought to eat the bread alone, that will be best of all. His evening feed should on this day be somewhat earlier than usual; and after this he is only to have a wisp of hay out of the groom's hand till he return from hunting.

HUNTER, Dr William, a celebrated anatomist and physician, was born on the 23d of May 1718, at Kilbride in the county of Lanerk in Scotland. He was the seventh of the children of John and Agnes Hunter, who resided on a small estate in that parish called *Long Calderwood*, which had been long in the possession of his family. His great grandfather by his father's side, was a younger son of Hunter of Hunterston, chief of the family of that name. At the age of fourteen his father sent him to the college of Glasgow. In this seminary he passed five years, and by his prudent behaviour and diligence acquired the esteem of the professors, and the reputation of being a good scholar. His father had designed him for the church: but the idea of subscribing to articles of faith was so repugnant to the liberal mode of thinking he had already adopted, that he felt an insuperable aversion to his theological pursuits. In this state of mind he happened to become acquainted with Dr Cullen, the late celebrated professor at Edinburgh, who was then just established in practice at Hamilton under the patronage of the duke of Hamilton. Dr Cullen's conversation soon determined him to lay aside all thoughts of the church, and to devote himself to the profession of physic. His father's consent having been previously obtained, Mr Hunter in 1737 went to reside with Dr Cullen. In the family of this excellent friend and preceptor he passed nearly three years: and these, as he has been often heard to acknowledge, were the happiest years of his life. It was then agreed, that he should go and prosecute his medical studies at Edinburgh and London, and afterwards return to settle at Hamilton in

partnership with Dr Cullen. He accordingly set out for Edinburgh in November 1740; and continued there till the following spring, attending the lectures of the medical professors, and amongst others those of the late Dr Alexander Monro, who many years afterwards, in allusion to this circumstance, styled himself his *old master*.

Mr Hunter arrived in London in the summer of 1741, and took up his residence at Mr, afterwards Dr, Smellie's, who was at that time an apothecary in Pall Mall. He brought with him a letter of recommendation to his countryman Dr James Douglas, from Mr Foulis, printer in Glasgow, who had been useful to the doctor in collecting for him different editions of Horace. Dr Douglas was then intent on a great anatomical work on the bones, which he did not live to complete, and was looking out for a young man of abilities and industry whom he might employ as a dissector. This induced him to pay particular attention to Mr Hunter; and finding him acute and sensible, he desired him to make him another visit. A second conversation confirmed the doctor in the good opinion he had formed of Mr Hunter; and without any farther hesitation he invited him into his family to assist in his dissections and to superintend the education of his son.—Mr Hunter having accepted Dr Douglas's invitation, was by his friendly assistance enabled to enter himself as a surgeon's pupil at St George's Hospital under Mr James Wilkie, and as a dissecting pupil under Dr Frank Nichols, who at that time taught anatomy with considerable reputation. He likewise attended a course of lectures on experimental philosophy by Dr Desaguliers. Of these means of improvement he did not fail to make a proper use. He soon became expert in dissection, and Dr Douglas was at the expence of having several of his preparations engraved. But before many months had elapsed, he had the misfortune to lose this excellent friend.—The death of Dr Douglas, however, made no change in the situation of our author. He continued to reside with the doctor's family, and to pursue his studies with the same diligence as before.

In 1743 he communicated to the Royal Society an essay on the Structure and Diseases of articulating Cartilages. This ingenious paper, on a subject which till then had not been sufficiently investigated, affords a striking testimony of the rapid progress he had made in his anatomical inquiries. As he had it in contemplation to teach anatomy, his attention was directed principally to this object; and it deserves to be mentioned as an additional mark of his prudence, that he did not precipitately engage in the attempt, but passed several years in acquiring such a degree of knowledge and such a collection of preparations, as might insure him success. Dr Nichols, to whom he communicated his scheme, and who declined giving lectures about that time in favour of the late Dr Lawrence, did not give him much encouragement to prosecute it. But at length an opportunity presented itself for the display of his abilities as a teacher. A society of navy surgeons had an apartment in Covent Garden, where they engaged the late Mr Samuel Sharpe to deliver a course of lectures on the operations of surgery. Mr Sharpe continued to repeat this course, till finding that it interfered too much with his other engagements,

Hunter.

Hunter.

engagements, he declined the task in favour of Mr Hunter; who gave the society so much satisfaction, that they requested him to extend his plan to anatomy, and at first he had the use of their room for his lectures. This happened in the winter of 1746. He is said to have experienced much solicitude when he began to speak in public: but the applause he met with soon inspired him with courage; and by degrees he became so fond of teaching, that for many years before his death he was never happier than when employed in delivering a lecture. The profits of his two first courses were considerable; but by contributing to the wants of different friends, he found himself at the return of the next season obliged to defer his lectures for a fortnight, merely because he had not money enough to defray the necessary expence of advertisements.

In 1747 he was admitted a member of the corporation of surgeons; and in the spring of the following year, soon after the close of his lectures, he set out in company with his pupil, Mr James Douglas, on a tour through Holland to Paris. His lectures suffered no interruption by this journey, as he returned to England soon enough to prepare for his winter-course, which began about the usual time.

At first he practised both surgery and midwifery: but to the former of these he had always an aversion. His patron, Dr James Douglas, had acquired considerable reputation in midwifery; and this probably induced Mr Hunter to direct his views chiefly to the same line of practice. His being elected one of the surgeon men-midwives, first to the Middlesex, and soon afterwards to the British Lying-in Hospital, assisted in bringing him forward in this branch of his profession, in which he was recommended by several of the most eminent surgeons of that time, who respected his anatomical talents and wished to encourage him. But these were not the only circumstances that contributed to his success. He owed much to his abilities, and much to his person and manner, which eminently qualified him for the practice of midwifery.

In 1750 he seems to have entirely relinquished his views in surgery; as in that year he obtained the degree of Doctor of Physic from the university of Glasgow, and began to practise as a physician. About this time he quitted the family of Mrs Douglas, and went to reside in Jermyn-street. In the summer of 1751 he revisited his native country, for which he always retained a cordial affection. His mother was still living at Long Calderwood, which was now become his property by the death of his brother James. Dr Cullen, for whom he always entertained a sincere regard, was then established at Glasgow, and had acquired considerable reputation both as a practitioner and teacher of physic; so that the two friends had the pleasure of being able to congratulate each other on their mutual prosperity. During this visit he showed his attachment to his little paternal inheritance by giving many instructions for repairing and improving it, and for purchasing any adjoining lands that might be offered for sale. After this journey to Scotland, to which he devoted only a few weeks, he was never absent from London, unless his professional engagements, as sometimes happened, required his attendance at a distance from the capital.

In 1755, on the resignation of Dr Laxard, one of

Hunter.

the physicians of the British lying-in hospital, we find the governess of that institution voting their "thanks to Dr Hunter for the services he had done the hospital, and for his continuing in it as one of the physicians:" so that he seems to have been established in this office without the usual form of an election. The year following he was admitted a licentiate of the Royal College of Physicians. Soon afterwards he was elected a member of the Medical Society; and to the *Observations and Inquiries* published by that society, he at different periods contributed several valuable papers.

In 1762, we find him warmly engaged in controversy, supporting his claim to different anatomical discoveries, in a work entitled *Medical Commentaries*, the style of which is correct and spirited. As an excuse for the tardiness with which he brought forth this work, he observes in his introduction, that it required a good deal of time, and he had little to spare; that the subject was unpleasant, and therefore he was very seldom in the humour to take it up. In this publication he confined himself chiefly to a dispute with the present learned professor of anatomy at Edinburgh, concerning injections of the testicle, the ducts of the lachrymal gland, the origia and use of the lymphatic vessels, and absorption by veins. He likewise defended himself against a reproach thrown upon him by Professor Monro senior, by giving a concise account of a controversy he was involved in with Mr Pott concerning the discovery of the *Hernia Congenita*. It was not long before Mr Pott took occasion to give the public his account of the dispute; and, in reply, Dr Hunter added a supplement to his commentaries. No man was ever more tenacious than Dr Hunter of what he conceived to be his anatomical rights. This was particularly evinced in the year 1780, when his brother communicated to the Royal Society a discovery he had made 25 years before, relative to the structure of the placenta, the communication between it and the uterus, and the vascularity of the spongy chorion. At the next meeting of the society, a letter was read, in which Dr Hunter put in his claim to the discovery in question. This letter was followed by a reply from Mr John Hunter, and here the dispute ended.

In 1762, when the queen became pregnant, Dr Hunter was consulted: and two years afterwards he had the honour to be appointed physician extraordinary to her majesty.

About this time his avocations were so numerous, that he became desirous of lessening his fatigue; and having noticed the ingenuity and assiduous application of the late Mr William Hewson, F. R. S. who was then one of his pupils, he engaged him first as an assistant, and afterwards as a partner in his lectures. This connection continued till the year 1770, when some dispute happened which terminated in a separation. Mr Hewson was succeeded in the partnership by Mr Cruikshank, whose anatomical abilities were deservedly respected.

In 1767, Dr Hunter was elected a fellow of the Royal Society: and in the year following communicated to that learned body observations on the bones, commonly supposed to be elephants bones, which have been found near the river Ohio in America. This was not the only subject of natural history on which

Hunter. our author employed his pen ; for in a subsequent volume of the Philosophical Transactions, we find him offering his remarks on some bones found in the rock of Gibraltar, and which he proves to have belonged to some quadruped. In the same work, likewise, he published an account of the nyl-ghau, an Indian animal not described before. In 1768, Dr Hunter became a fellow of the Society of Antiquaries; and the same year, at the institution of a Royal Academy of Arts, he was appointed by his majesty to the office of professor of anatomy. This appointment opened a new field for his abilities; and he engaged in it, as he did in every other pursuit of his life, with unabating zeal. He now adapted his anatomical knowledge to the objects of painting and sculpture, and the novelty and justness of his observations proved at once the readiness and extent of his genius. In January 1781, he was unanimously elected to succeed the late Dr John Fothergill as president of the Medical Society. As his name and talents were known and respected in every part of Europe, so the honours conferred on him were not limited to his own country. In 1780, the Royal Medical Society at Paris elected him one of their foreign associates; and in 1782, he received a similar mark of distinction from the Royal Academy of Sciences in that city.

The most splendid of Dr Hunter's medical publications was the Anatomy of the Human Gravid Uterus. The appearance of this work, which had been begun so early as the year 1751 (at which time 10 of the 34 plates it contains were completed), was retarded till the year 1775, only by the author's desire of sending it into the world with fewer imperfections. This great work is dedicated to the king. In his preface to it, we find the author very candidly acknowledging, that in most of the dissections he had been assisted by his brother Mr John Hunter, "whose accuracy (he adds) in anatomical researches is so well known, that to omit this opportunity of thanking him for that assistance would be in some measure to disregard the future reputation of the work itself." He likewise confesses his obligations to the ingenious artists who made the drawings and engravings; "but particularly to Mr Strange, not only for having by his hand secured a sort of immortality to two of the plates, but for having given his advice and assistance in every part with a steady and disinterested friendship." An anatomical description of the gravid uterus was a work which Dr Hunter had in contemplation to give the public. He had likewise long been employed in collecting and arranging materials for a history of the various concretions that are formed in the human body. Amongst Dr Hunter's papers have been found two introductory lectures, which are written out so fairly, and with such accuracy, that he probably intended no farther correction of them before they should be given to the world. In these lectures Dr Hunter traces the history of anatomy from the earliest to the present times, along with the general progress of science and the arts. He considers the great utility of anatomy in the practice of physic and surgery; gives the ancient divisions of the different substances composing the human body, which for a long time prevailed in anatomy; points out the most advantageous mode of cultivating this branch of natural knowledge; and concludes with explaining the particular plan of his own

lectures. Besides these manuscripts, he has also left behind him a considerable number of cases of dissection; mostly relating to pregnant women.

The same year in which the Tables of the Gravid Uterus made their appearance, Dr Hunter communicated to the Royal Society an Essay on the Origin of the Venereal Disease. In this paper he attempted to prove, that this dreadful malady was not brought from America to Europe by the crew of Columbus, as had been commonly supposed, although it made its first appearance about that period. After this paper had been read to the Royal Society, Dr Hunter, in a conversation with the late Dr Musgrave, was convinced that the testimony on which he placed his chief dependence was of less weight than he had at first imagined, as many of Martyr's letters afford the most convincing proofs of their having been written a considerable time after the period of their dates. He therefore very properly laid aside his intention of giving his essay to the public. In the year 1777 Dr Hunter joined with Mr Watson in presenting to the Royal Society a short account of the late Dr Maty's illness, and of the appearances on dissection; and the year following he published his Reflections on the Section of the Symphysis Pubis.

We must now go back a little in the order of time to describe the origin and progress of Dr Hunter's museum, without some account of which the history of his life would be very incomplete.

When he began to practise midwifery, he was desirous of acquiring a fortune sufficient to place him in easy and independent circumstances. Before many years had elapsed, he found himself in possession of a sum adequate to his wishes in this respect; and this he set apart as a resource of which he might avail himself whenever age or infirmities should oblige him to retire from business. After he had obtained this competency, as his wealth continued to accumulate, he formed a laudable design of engaging in some scheme of public utility, and at first had it in contemplation to found an anatomical school in this metropolis. For this purpose, about the year 1775, during the administration of Mr Grenville, he presented a memorial to that minister, in which he requested the grant of a piece of ground in the Mews, for the site of an anatomical theatre. Dr Hunter undertook to expend 7000l. on the building, and to endow a professorship of anatomy in perpetuity. This scheme did not meet with the reception it deserved. In a conversation on this subject soon afterwards with the earl of Shelburne, his lordship expressed a wish that the plan might be carried into execution by subscription, and very generously requested to have his name set down for a thousand guineas. Dr Hunter's delicacy would not allow him to adopt this proposal. He chose rather to execute it at his own expence; and accordingly purchased a spot of ground in Great Windmill-street, where he erected a spacious house, to which he removed from Jermyn-street in 1770. In this building, besides a handsome amphitheatre and other convenient apartments for his lectures and dissections, there was one magnificent room, fitted up with great elegance and propriety as a museum. Of the magnitude and value of his anatomical collection some idea may be formed, when we consider the great length of

Hunter.

Hunter. years he employed in the making of anatomical preparations and in the dissection of morbid bodies, added to the eagerness with which he procured additions from the collections of Sandys, Hewson, Falconer, Blackall, and others, that were at different times offered for sale in this metropolis. His specimens of rare diseases were likewise frequently increased by presents from his medical friends and pupils; who, when any thing of this sort occurred to them, very justly thought they could not dispose of it more properly than by placing it in Dr Hunter's museum. Speaking of an acquisition in this way in one of his publications, he says, "I look upon every thing of this kind which is given to me, as a present to the public; and consider myself as thereby called upon to serve the public with more diligence."

Before his removal to Windmill-street, he had confined his collection chiefly to specimens of human and comparative anatomy and of diseases; but now he extended his views to fossils, and likewise to the promotion of polite literature and erudition. In a short space of time he became possessed of "the most magnificent treasure of Greek and Latin books that has been accumulated by any person now living since the days of Mead." A cabinet of ancient medals contributed likewise much to the richness of his museum. A description of part of his coins in this collection, struck by the Greek free cities, was afterwards published by the Doctor's learned friend Mr Combe. In a classical dedication of this elegant volume to the queen, Dr Hunter acknowledges his obligations to her majesty. In the preface some account is given of the progress of the collection, which has been brought together since the year 1770, with singular taste, and at the expence of upwards of 20,000*l*. In 1781, the museum received a valuable addition of shells, corals, and other curious subjects of natural history, which had been collected by the late worthy Dr Fothergill, who gave directions by his will, that his collection should be appraised after his death, that Dr Hunter should have the refusal of it at 500*l*. under the valuation. This was accordingly done, and Dr Hunter purchased it for the sum of 1200*l*. The fame of this museum spread throughout Europe. Few foreigners distinguished for their rank or learning visited this metropolis without requesting to see it. Men of science of our own country always had easy access to it.—Considered in a collective point of view, it is perhaps without a rival.

Dr Hunter, at the head of his profession, honoured with the esteem of his sovereign, and in possession of every thing that his reputation and wealth could confer, seemed now to have attained the summit of his wishes. But these sources of gratification were embittered by a disposition to the gout, which harassed him frequently during the latter part of his life, notwithstanding his very abstemious manner of living. On Saturday the 15th of March 1783, after having for several days experienced a return of a wandering gout, he complained of great headach and nausea. In this state he went to bed, and for several days felt more pain than usual both in his stomach and limbs. On the Thursday following he found himself so much recovered, that he determined to give the introductory lecture to the operations of surgery. It was to no purpose that his friends urged to him the impropriety of such an at-

tempt. He was determined to make the experiment, and accordingly delivered the lecture; but towards the conclusion his strength was so exhausted that he fainted away, and was obliged to be carried to bed by two servants. The following night and day his symptoms were such as indicated danger; and on Saturday morning Mr Combe, who made him an early visit, was alarmed on being told by Dr Hunter himself, that during the night he had certainly had a paralytic stroke. As neither his speech nor his pulse were affected, and he was able to raise himself in bed, Mr Combe encouraged him to hope that he was mistaken. But the event proved the doctor's idea of his complaint to be but too well founded; for from that time till his death, which happened on Sunday the 30th of March, he voided no urine without the assistance of the catheter, which was occasionally introduced by his brother; and purgative medicines were administered repeatedly without procuring a passage by stool. These circumstances, and the absence of pain, seemed to show, that the intestines and urinary bladder had lost their sensibility and power of contraction; and it was reasonable to presume that a partial palsy had affected the nerves distributed to those parts.

By his will, the use of his museum, under the direction of trustees, devolved to his nephew Dr Matthew Baillie, and in case of his death to Mr Cruikshank for the term of thirty years; at the end of which period the whole collection is bequeathed to the university of Glasgow, with eight thousand pounds sterling as a fund for the support and augmentation of the collection, which is now deposited at Glasgow.

Dr Hunter was regularly shaped, but of a slender make, and rather below a middle stature. His manner of living was extremely simple and frugal, and the quantity of his food was small as well as plain. He was an early riser; and when business was over, was constantly engaged in his anatomical pursuits, or in his museum. There was something very engaging in his manner and address; and he had such an appearance of attention to his patients, when he was making his inquiries, as could hardly fail to conciliate their confidence and esteem. In consultation with his medical brethren, he delivered his opinions with diffidence and candour. In familiar conversation he was cheerful and unassuming. As a teacher of anatomy he has been long and deservedly celebrated. He was a good orator; and having a clear and accurate conception of what he taught, he knew how to place in distinct and intelligible points of view the most abstruse subjects of anatomy and physiology. Among other methods of explaining and illustrating his doctrines, he used frequently to introduce some apposite story or case that had occurred to him in his practice; and few men had acquired a more interesting fund of anecdotes of this kind, or related them in a more agreeable manner.

HUNTER, John, an eminent surgeon, was the youngest child of John Hunter of Kilbride, in the county of Lanark. He was born at Long Calderwood on the 13th of July 1728. His father died when he was about ten years of age, from which circumstance his mother was induced to grant him too much indulgence. In consequence he made no progress at the grammar-school, and was almost wholly illiterate at the age of 20, when

Hunter. he arrived in London. His brother Dr W. Hunter was at that time the most eminent teacher of anatomy, and John expressed a wish to attend him in his researches. The doctor, anxious to make trial of his talents, gave him an arm to dissect for the muscles, with proper instructions how it was to be performed; and the dexterity with which he managed his undertaking exceeded the expectations of his brother.

Having acquired some reputation from this first attempt, his brother employed him in a more difficult dissection, which was an arm wherein all the arteries were injected, and these and the muscles were to be preserved and exposed. In the execution of this task he also gave the highest satisfaction, and his brother predicted that he would become a good anatomist, and never want employment. Under the instructions of his brother, and Mr Symonds his assistant, he enjoyed every favourable opportunity of increasing his anatomical knowledge, since that school monopolized all the dissections then carried on in London.

He was admitted into partnership with his brother in the winter of 1755, and a certain department of the lectures was allotted to him, and he also lectured when the doctor was called away to attend his patients. The mind of Mr Hunter was peculiarly fitted for the study of anatomy, and the indefatigable ardour with which he prosecuted it is scarcely to be equalled. He applied to human anatomy for ten years, during which period he made himself master of every thing then known, and also made some considerable additions. He was the first who discovered the existence of the lymphatic vessels in birds.

With such eagerness did he apply himself to the study of comparative anatomy, that he even applied to the keeper of wild beasts in the Tower for the bodies of such as died there, and to all those who were in the habit of exhibiting wild beasts to the public. He made a purchase of every rare animal that came in his way, which, together with those presented to him by his friends, he gave to the showmen to keep till they died, the more effectually to prevail with them to assist him in his labours. So much was his health impaired by unwearied attention to his favourite pursuits, that in 1760 his friends advised him to go abroad, as he exhibited many symptoms of an incipient consumption. In October that year he was appointed a surgeon on the staff by the inspector-general of hospitals (Mr Adair), and in the spring of the ensuing year he went to Belleisle with the army.

He served during the continuance of the war, as senior surgeon on the staff, when he acquired his knowledge of gun-shot wounds. He settled in London on his return to England; but finding that his half pay and private practice could not support him, he taught practical anatomy and surgery for several winters. He built a house near Brompton, where he pursued the study of comparative anatomy with unabated ardour. He discovered the changes which animal and vegetable substances undergo in the stomach by the action of the gastric juice; the mode in which a bone retains its shape during its growth; and explained the process of exfoliation, by which a piece of dead bone is separated from the living.

On the 5th of February 1767, he was chosen F. R. S. In the year 1768 he became a member of the incorpo-

ration of surgeons, and in the following year was elected one of the surgeons of St George's hospital, through the influence of his brother. He published his treatise on the natural history of the teeth in May 1771, and in July the same year he married Miss Home, daughter of Mr Home, surgeon to Burgoyne's regiment of light horse. His private practice and professional reputation advanced with rapidity after his marriage, and although his family increased, he devoted much of his time to the forming of his collection. He discovered the cause of failure in the cure of every case of hydrocele, and proposed a mode of operating in which that event may certainly be avoided. He ascertained that simple exposure to the air can neither produce nor increase inflammation; and he considered the blood as alive in its fluid state. He also discovered that the stomach after death is sometimes acted on and dissolved by the gastric juice, respecting which he communicated a paper to the Royal Society.

Comparative anatomy occupied the greater part of his time and attention, and he suffered no opportunity to escape him. He dissected the torpedo in 1773, and laid an account of its electrical organs before the Royal Society. A young elephant which had been presented to the queen, having died, it was given to Dr Hunter, which afforded our author an opportunity of examining the structure of that monstrous animal, as did also two others which died in the queen's menagerie. In the year 1774, he published an account, in the Philosophical Transactions, of certain receptacles of air in birds, communicating with the lungs, and lodged in the muscular parts and hollow bones of these animals. Several animals belonging to the species called *Gymnotus electricus* of Surinam having been brought alive to Britain in 1775, their electrical properties excited a considerable share of the public attention, and Mr Hunter purchased many of them after they died, for the purpose of prosecuting his favourite experiments. He published an account of their electrical organs in the Philosophical Transactions for 1775; and in the same volume appeared his experiments on the power of animals and vegetables to produce heat.

Mr Hunter was appointed surgeon extraordinary to his majesty in 1776; in the autumn of which year he grew extremely ill, when both himself and his friends apprehended that his life was in danger, but he happily recovered so far as to be able to publish the second part of his treatise on the Teeth in 1778, which completed the subject; and in 1779 he published in the Philosophical Transactions his account of the Free Martin. He was chosen a fellow of the Royal Society of Sciences and Belles Lettres at Gottenburg, and in 1783 he became a member of the Royal Society of Medicine and the Royal Academy of Surgery in Paris.

In the building which he formed for his valuable collection, there was a room 52 feet by 28, lighted from the top, with a gallery all round, for containing his preparations. At this time he had reached the height of his career as a surgeon, with his mind and body in full vigour; and his hands were capable of performing whatever was suggested by his capacious mind, and his judgement was fully ripened by long experience.

He removed a tumor from the head and neck of a patient in St George's hospital, as large as the head to which it was attached; and by bringing the cut

Hunter.

edges of the skin into contact, the whole was almost healed by the first intention. He dissected or cut out a tumor on the neck, which one of the best surgeons in this country declared that none but a fool or a madman would ever attempt; yet the patient perfectly recovered. He discovered a new method of performing the operation for the popliteal aneurism, by taking up the femoral artery on the anterior part of the thigh, without doing any thing to the tumor or the ham. This, from many subsequent experiments which have been successfully performed, must be allowed to stand high among the modern improvements in surgery.

Mr Hunter was engaged in a very extensive private practice; he was surgeon to St George's hospital; he gave a very long course of lectures during the winter season; he carried on his inquiries in comparative anatomy; he had a school of practical human anatomy in his own house, and was continually employed in some experiments respecting the animal economy. In 1786 he was chosen deputy surgeon-general to the army, at which time he published his work on the venereal disease, the first edition of which met with a very rapid sale.

In the year 1787 he published a treatise on the effect of extirpating one ovary on the number of young, which procured him the annual gold medal of Sir John Copley. His collection was now brought into a state of arrangement, which he shewed to his friends and acquaintances twice a year, and in May to noblemen and gentlemen, who were only in town during the spring. When Mr Adair died, Mr Hunter was appointed inspector general of hospitals, and surgeon-general to the army. This event happened in 1792, at which time he was elected honorary member of the Chirurgo-Physical Society of Edinburgh, and one of the vice-presidents of the Veterinary College of London, then first established. He published also three papers on the treatment of inflamed veins, on intussusception, and on the mode of conveying food into the stomach in cases of paralysis of the œsophagus.

The collection of comparative anatomy left by Mr Hunter remains an unequivocal testimony of his perseverance and abilities, and an honour to the country in which he was educated. In it is beheld the natural gradation from the lowest state in which life is found to exist, up to the most perfect and complex of the animal creation—man himself.

Mr Hunter enjoyed a good state of health, for the first 40 years of his life, during which he had no complaint of any consequence, except an inflammation of his lungs in 1759. The first attack of the gout which he ever experienced was occasioned by an affection of the mind, and every subsequent fit originated from the same source.

Mr Hunter was of a short stature, uncommonly strong and active, well formed, and capable of great bodily exertion. His countenance was open, animated, and deeply impressed with thoughtfulness towards the close of his life. Lavater seeing a print of him, is said to have exclaimed, "that man thinks for himself." For the last twenty years of his life he drank nothing stronger than water, and wine at no period agreed with his stomach. He was easily irritated, and not soon pacified when once provoked. He was an enemy to dissimulation, and free even to a fault. Few men re-

quire so little relaxation as Mr Hunter did, for he seldom slept above four hours in the night, but always an hour after dinner. In private practice he was scrupulously honest in declaring his opinion of the case before him, and ready on all occasions to confess his ignorance of what he did not understand. He sometimes spoke harshly of his cotemporaries; which did not originate from envy, but from a full conviction that surgery was as yet in its infancy, and he himself a novice in his own art.

On October the 16th 1793, when in his usual state of health, he went to St George's hospital, and meeting with some things which irritated his mind, and not being perfectly master of the circumstances, he withheld his sentiments; in which state of restraint he went into the next room, and turning round to Dr Robertson, one of the physicians of the hospital, he gave a deep groan and dropt down dead, being then in his 65th year, the same age at which his brother Dr Hunter had died.

HUNTING, the exercise or diversion of pursuing four-footed beasts of game. See the article GAME.

Four-footed beasts are hunted in the fields, woods, and thickets, and that both with guns and gre-hounds.

Birds, on the contrary, are either shot in the air, or taken with nets and other devices, which exercise is called *fowling*; or they are pursued and taken by birds of prey, which is called *hawking*. See the articles FOWLING, HAWKING, FALCONRY, SHOOTING, *BIRD-Catching*, and DECOY.

F. de Launay, professor of the French laws, has an express treatise of hunting. From those words of God to Adam, Gen. i. 26. and 28. and to Noah, Gen. ix. 2, 3. hunting was considered as a right devolved or made over to man; and the following ages appear to have been of the same sentiment. Accordingly we find, that among the more civilized nations it made one of their diversions; and as to the wilder and more barbarous it served them with food and necessaries. The Roman jurisprudence, which was formed on the manners of the first ages, made a law of it, and established it as a maxim, that as the natural right of things which have no master belongs to the first possessor, wild beasts, birds, and fishes, are the property of whomsoever can take them first.

But the northern nations of barbarians who overran the Roman empire, bringing with them a stronger taste for the diversion, and the people being now possessed of other and more easy means of subsistence from the lands and possessions of those they had vanquished, their chiefs and leaders began to appropriate the right of hunting, and, instead of a natural right, to make it a royal one. Thus it continues to this day; the right of hunting, among us, belonging only to the king, and those who derive it from him.

The hunting used by the ancients was much like that now practised for the rein-deer; which is seldom hunted at force, or with hounds; but only drawn with a blood-hound, and forestalled with nets and engines. Thus did they with all beasts; whence a dog is never commended by them for opening before he has discovered where the beast lies. Hence, they were not in any manner curious as to the music of their hounds, or the composition of their kennel or pack, either for

deepness,

Hunter,
Hunting.

ing. deepness, loudness, or sweetness of cry, which is a principal point in the hunting of our days. Their huntmen, indeed, were accustomed to shout and make a great noise, as Virgil observes in the third of his *Georgics*: *Ingentem clamore premea ad retia cervum*. But that confusion was only to bring the deer to the nets laid for him.

The Sicilian way of hunting had something in it very extraordinary.—The nobles or gentry being informed which way a herd of deer passed, gave notice to one another, and appointed a meeting; every one bringing with him a cross-bow or long-bow, and a bundle of staves shod with iron, the heads bored, with a cord passing through them all: thus provided, they came to the herd, and, casting themselves about in a large ring, surrounded the deer.—Then, each taking his stand, unbound his faggot, set up his stake, and tied the end of the cord to that of his next neighbour, at the distance of ten feet from one another.—Then taking feathers, dyed in crimson, and fastened on a thread, they tied them to the cord; so that with the least breath of wind they would whirl round.—Which done, the persons who kept the stands withdrew, and hid themselves in the next covert. Then the chief ranger entering within the line with bounds to draw after the herd, roused the game with their cry; which flying towards the line, were turned off; and, still gazing on the shaking and shining feathers, wandered about as if kept in with a real wall or pale. The ranger still pursued, and calling every person by name as he passed by their stand, commanded him to shoot the first, third, or sixth, as he pleased: and if any of them missed, or singled out another than that assigned him, it was counted a grievous disgrace. By such means, as they passed by the several stations, the whole herd was killed by the several hands. *Pier. Hieroglyphic. lib. vii. cap. 6.*

Hunting formed the greatest part of the employment of the ancient Germans, and probably of the Britons also, when they were not engaged in war. We are informed by some ancient historians, that this was the case even as late as the third century with the unconquered Britons who lived beyond Adrian's wall; nay, that they subsisted chiefly by the prey they took in this way. The great attachment shown by all the Celtic nations to hunting, however, proceeded most probably from its being a kind of apprenticeship to war. Thus their youth acquired that courage, strength, swiftness, and dexterity in handling their arms, which made them so formidable in time of war to their enemies. Thus also they freed the country from many mischievous animals which abounded in the forests, furnishing themselves also with materials for those feasts which seem to have constituted their greatest pleasure. The young chieftains had thus likewise an opportunity of paying court to their mistresses, by displaying their bravery and agility, and making them presents of their game; nay, so strong and universal was the passion for hunting among the ancient Britons, that young ladies of the highest quality and greatest beauty spent much of their

time in the chase. They employed much the same weapons in hunting that they did in war, viz. long spears, javelins, and bows and arrows; having also great numbers of dogs to assist them in finding and pursuing their game. These dogs, we are also told, were much admired among other nations, on account of their swiftness, strength, fierceness, and exquisite sense of smelling. They were of several different kinds, called by different names, and formed a considerable article of commerce. They were highly valued by all the Celtic nations, insomuch that some very comical penalties were inflicted upon those who were convicted of stealing them (A). From the poems of Ossian also it appears, that the Britons were not unacquainted with the art of catching birds with hawks trained for that purpose; but they seem to have been absolutely ignorant of the method of catching fish; for there is not a single allusion to this art in all the works of that venerable bard. Their ignorance of this art is both confirmed and accounted for by Dio Niceus, who assures us, that the ancient Britons never tasted fish, though they had innumerable multitudes in their seas, rivers, and lakes. "By the bye (says Dr Henry), we may observe that this agreement between the poems of Ossian and the Greek historian, in a circumstance so singular, is at once a proof of the genuine antiquity of these poems, and that the Greek and Roman writers were not so ill informed about the affairs and manners of the ancient Britons as some have imagined."

The Mexicans, whatever imbecility may be imputed to them in other respects, were very dexterous in hunting. They used bows and arrows, darts, nets, snares, and a kind of tubes named *carbottans*, through which they shot by blowing out little balls at birds. Those which the kings and great men made use of were curiously carved and painted, and likewise adorned with gold and silver. Besides the exercise of the chase which private individuals took either for amusement or to provide food for themselves, there were general hunting-matches, sometimes appointed by the king; at others, undertaken with a view to provide plenty of victims for sacrifices. A large wood, generally that of Zacatapec, not far distant from the capital, was pitched upon as the scene of these grand hunting-matches. Here they chose the place best adapted for setting a great number of snares and nets. The wood was inclosed by some thousands of hunters, forming a circle of six, seven, or eight miles, according to the number of animals they intended to take. Fire was then set to the grass in a great number of places, and a terrible noise made with drums, horns, shouting, and whistling. The hunters gradually contracted their circle, continuing the noise till the game were inclosed in a very small space. They were then killed or taken in snares, or with the hands of the hunters. The number of animals taken or destroyed on these occasions was so great, that the first Spanish viceroy of Mexico would not believe it without making the experiment himself. The place chosen for his hunting-match was a great plain in the country of the

Hunting.

(A) Si quis canem veltraum aut segutium vel petrunculum, præsumerit involare, jubemus at convictus, coram omni populo, posteriora ipsius osculetur.

Hunting.

the Otomies, lying between the villages of Xilotepec and S. Giovanni del Rio; the Indians being ordered to proceed according to their usual customs in the times of their paganism. The viceroy, attended by a vast retinue of Spaniards, repaired to the place appointed, where accommodations were prepared for them in houses of wood erected for the purpose. A circle of more than 15 miles was formed by 11,000 Otomies, who started such a quantity of game on the plain, that the viceroy was quite astonished, and commanded the greater part of them to be set at liberty, which was accordingly done. The number retained, however, was still incredibly great, were it not attested by a witness of the highest credit. On this occasion upwards of 600 deer and wild goats, 100 cajotes, with a surprising number of hares, rabbits, and other smaller animals. The plain still retains the Spanish name *Cuzadero*, which signifies the "place of the chase."

The Mexicans, besides the usual methods of the chase, had particular contrivances for catching certain animals. Thus, to catch young asses, they made a small fire in the woods, putting among the burning coals a particular kind of stone named *cacalotti*, "raven or black stone," which bursts with a loud noise when heated. The fire was covered with earth, and a little maize laid around it. The asses quickly assembled with their young, in order to feed upon the maize; but while they were thus employed, the stone burst, and scared away the old ones by the explosion, while the young ones, unable to fly, were carried off by the hunters. Serpents were taken even by the hands, seizing them intrepidly by the neck with one hand, and sewing up their mouths with the other. This method is still practised. They showed the greatest dexterity in tracing the steps of wild beasts, even when an European could not have discerned the smallest print of their feet. The Indian method, however, was by observing sometimes the herbs or leaves broken down by their feet; sometimes the drops of blood which fell from them when wounded. It is said that some of the American Indians show still greater dexterity in discovering the tracks of their enemies, which to an European would be altogether imperceptible.

Hunting was a favourite diversion of the great and bloody conqueror Jenghiz Khan, if indeed we can apply the word *diversion* to a monster whose mind was set upon the destruction of his own species, and who only endeavoured to make the murder of brutes subservient to that of men, by keeping his soldiers in a kind of warfare with the beasts when they had no human enemies to contend with. His expeditions were conducted on a plan similar to that of the Mexicans already mentioned; and were no doubt attended with still greater success, as his numerous army could enclose a much greater space than all the Indians whom the Spanish viceroy could muster. The East Indian princes still show the same inclination to the chase; and Mr Blane, who attended the hunting excursions of Asoph Ul Dowlah visir of the Mogul empire and nabob of Oude in 1785 and 1786, gives the following account of the method practised on this occasion.

The time chosen for the hunting party is about the beginning of December; and the diversion is continued till the heats, which commence about the beginning of March, oblige them to stop. During this time a cir-

Hunting

cuit of between 400 and 600 miles is generally made; the hunters bending their course towards the skirts of the northern mountains, where the country is wild and uncultivated. The visir takes along with him not only his court and seraglio, but a great part of the inhabitants of his capital. His immediate attendants may amount to about 2000; but besides these he is also followed by 500 or 600 horse, and several battalions of regular sepoy with their field-pieces. Four or five hundred elephants are also carried along with him: of which some are used for riding, others for fighting, and some for clearing the jungles and forests of the game. About as many sumpter horses of the beautiful Persian and Arabian breeds are carried along with him. A great many wheel carriages drawn by bullocks likewise attend, which are used chiefly for the convenience of the women; sometimes also he has an English chaise or two, and sometimes a chariot; but all these as well as the horses are merely for show, the visir himself never using any other conveyance than an elephant, or sometimes when fatigued or indisposed a palanquin. The animals used in the sport are principally grehounds, of which there may be about 300; he has also about 200 hawks, and a few trained leopards for hunting deer. There are a great number of marksmen, whose profession it is to shoot deer; with many fowlers, who provide game: as none of the natives of India know how to shoot game with small shot, or to hunt with slow bounds. A vast number of matchlocks are carried along with the company, with many English pieces of various kinds, 40 or 50 pairs of pistols, bows and arrows, besides swords, daggers, and sabres without number. There are also nets of various kinds, some for quail, and others very large, for fishing, which are carried along with him upon elephants, attended by fishermen, so as always to be ready for throwing into any river or lake that may be met with. Every article that can contribute to luxury or pleasure is likewise carried along with the army. A great many carts are loaded with the Ganges water, and even ice is transported for cooling the drink. The fruits of the season and fresh vegetables are daily sent to him from his gardens by bearers stationed at the distance of every ten miles; by which means each article is conveyed day or night at the rate of four miles an hour. Besides the animals already mentioned, there are also fighting antelopes, buffaloes, and rams in great numbers; also several hundred pigeons, some fighting cocks, with a vast variety of parrots, nightingales, &c.

To complete the magnificence or extravagance of this expedition, there is always a large bazar, or moving town, which attends the camp; consisting of shopkeepers and artificers of all kinds, money-changers, dancing-women; so that, on the most moderate calculation, the whole number of people in his camp cannot be computed at fewer than 20,000. The nabob himself, and all the gentlemen of his camp, are provided with double sets of tents and equipage, which are always sent on the day before to the place to which he intends to go; and this is generally eight or ten miles in whatever direction most game is expected; so that by the time he has finished his sport in the morning, he finds his whole camp ready pitched for his reception.

Hunting.

The nabob, with the attending gentlemen, proceed in a regular moving court or durbar, and thus they keep conversing together and looking out for game. A great many foxes, hares, jackals, and sometimes deer, are picked up by the dogs as they pass along: the hawks are carried immediately before the elephants, and let fly at whatever game is sprung for them, which is generally partridges, bustards, quails, and different kinds of herons; these last affording excellent sport with the falcons or sharp-winged hawks. Wild boars are sometimes started, and either shot or run down by the dogs and horsemen. Hunting the tyger, however, is looked upon as the principal diversion, and the discovery of one of these animals is accounted a matter of great joy. The cover in which the tyger is found is commonly long grass, or reeds of such a height as frequently reach above the elephants; and it is difficult to find him in such a place, as he commonly endeavours either to steal off, or lies so close to the ground that he cannot be roused till the elephants are almost upon him. He then roars and skulks away, but is shot at as soon as he can be seen; it being generally contrived that the nabob shall have the compliment of firing first. If he be not disabled, the tyger continues to skulk along, followed by the line of elephants; the nabob and others shooting at him as often as he can be seen till he falls. The elephants themselves are very much afraid of this terrible animal, and discover their apprehensions by shrieking and roaring as soon as they begin to smell him or hear him growl; generally attempting to turn away from the place where he is. When the tyger can be traced to a particular spot, the elephants are disposed of in a circle round him; in which case he will at last make a desperate attack, springing upon the elephant that is nearest, and attempting to tear him with his teeth or claws. Some, but very few, of the elephants, can be brought to attack the tyger; and this they do by curling up their trunks under their mouths, and then attempting to toss, or otherwise destroy him with their tusks, or to crush him with their feet or knees. It is considered as good sport to kill one tyger in a day; though sometimes, when a female is met with her young ones, two or three will be killed.

The other objects of pursuit in these excursions are wild elephants, buffaloes, and rhinoceroses. Our author was present at the hunting of a wild elephant of vast size and strength. An attempt was first made to take him alive by surrounding him with tame elephants, while he was kept at bay by crackers and other fire-works; but he constantly eluded every effort of this kind. Sometimes the drivers of the tame elephants got so near him, that they threw strong ropes over his head, and endeavoured to detain him by fastening them around trees; but he constantly snapped the ropes like pack-threads, and pursued his way to the forest. Some of the strongest and most furious of the fighting elephants were then brought up to engage him; but he attacked them with such fury that they were all obliged to desist. In his struggle with one of them he broke one of his tusks, and the broken piece, which was upwards of two inches in diameter, of solid ivory, flew up into the air several yards above their heads. Orders were now given to kill him, as

it appeared impossible to take him alive; but even this was not accomplished without the greatest difficulty. He twice turned and attacked the party who pursued him; and in one of these attacks struck the elephant obliquely on which the prince rode, threw him upon his side, but then passed on without offering farther injury. At last he fell dead, after having received as was supposed upwards of 1000 balls into his body.

Notwithstanding the general passion among most nations for hunting, however, it has by many been deemed an exercise inconsistent with the principles of humanity. The late king of Prussia expressed himself on this subject in the following manner. "The chase is one of the most sensual of pleasures, by which the powers of the body are strongly exerted, but those of the mind remain unemployed. It is an exercise which makes the limbs strong, active, and pliable: but leaves the head without improvement. It consists in a violent desire in the pursuit, and the indulgence of a cruel pleasure in the death, of the game. I am convinced that man is more cruel and savage than any beast of prey: We exercise the dominion given us over these our fellow-creatures in the most tyrannical manner. If we pretend to any superiority over the beasts, it ought certainly to consist in reason; but we commonly find that the most passionate lovers of the chase renounce this privilege, and converse only with their dogs, horses, and other irrational animals. This renders them wild and unfeeling; and it is probable that they cannot be very merciful to the human species. For a man who can in cold blood torture a poor innocent animal, cannot feel much compassion for the distresses of his own species. And, besides, can the chase be a proper employment for a thinking mind?"

The arguments used by his majesty against hunting seem indeed to be much confirmed by considering the various nations who have most addicted themselves to it. These, as must be seen from what has already been said, were all barbarous; and it is remarkable, that Nimrod, the first great hunter of whom we have any account, was likewise the first who oppressed and enslaved his own species. As nations advanced in civilization, it always became necessary to restrain by law the inclination of the people for hunting. This was done by the wise legislator Solon, lest the Athenians should neglect the mechanic arts on its account. The Lacedæmonians, on the contrary, indulged themselves in this diversion without controul; but they were barbarians, and most cruelly oppressed those whom they had in their power, as is evident from their treatment of the Helots. The like may be said of the Egyptians, Persians, and Scythians; all of whom delighted in war, and oppressed their own species. The Romans, on the other hand, who were somewhat more civilized, were less addicted to hunting. Even they, however, were exceedingly barbarous, and found it necessary to make death and slaughter familiar to their citizens from their infancy. Hence their diversions of the amphitheatre and circus, where the hunting of wild beasts was shown in the most magnificent and cruel manner; not to mention their still more cruel sport of gladiators, &c.

In two cases only does it seem possible to reconcile the practice of hunting with humanity; viz. either when

Hunting.

Hunting. when an uncultivated country is overrun with noxious animals; or when it is necessary to kill wild animals for food. In the former case, the noxious animals are killed because they themselves would do so if they were allowed to live; but if we kill even a lion or a tyger merely for the pleasure of killing him, we are undoubtedly chargeable with cruelty. In like manner, our modern foxhunters expressly kill foxes, not in order to destroy the breed of these noxious animals, but for the pleasure of seeing them exert all their power and cunning to save their lives, and then beholding them torn in pieces after being half dead with fatigue. This refinement in cruelty, it seems, is their favourite diversion; and it is accounted a crime for any person to destroy these animals in self-defence, as appears from the following passage in Mr Beckford's treatise on hunting. "Besides the digging of foxes, by which method many young ones are taken and old ones destroyed, traps, &c. are too often fatal to them. Farmers for their lambs, (which, by the bye, few foxes ever kill), gentlemen for their game, and old women for their poultry, are their inveterate enemies. In the country where I live, most of the gentlemen are sportsmen; and even those who are not, show every kind of attention to those who are. I am sorry it is otherwise with you; and that your old gouty neighbour should destroy your foxes, I must own concerns me. I know some gentlemen, who, when a neighbour had destroyed all their foxes, and thereby prevented them from pursuing a favourite amusement, loaded a cart with spaniels, and went all together and destroyed his pheasants. I think they might have called this very properly *lex talionis*: and it had the desired effect; for as the gentleman did not think it prudent to fight them all, he took the wiser method, he made peace with them. He gave an order that no more foxes should be destroyed, and they never afterwards killed any of his pheasants."

In the first volume of the Manchester Transactions we have a dissertation upon the diversions of hunting, shooting, &c. as compatible with the principles of humanity. One argument used by the author is, that death is no positive evil to brutes. "It would perhaps (says he) be too hasty an assertion to affirm, that death to brutes is no evil. We are not competent to determine whether their existence, like our own, may not extend to some future mode of being, or whether the present limited sphere is all in which they are interested. On so speculative a question little can be advanced with precision; nor is it necessary for the investigation of the subject before us. If we may be allowed to reason from what we know, it may be safely conjectured, that death to brutes is no positive evil: we have no reason to believe they are endowed with foresight; and therefore, even admitting that with them the pleasures of life exceed its pains and cares, in terminating their existence, they only suffer a privation of pleasure."

On this extraordinary piece of reasoning we may observe, that it would hold much more against the human species than against the brutes. There are few amongst us willing to allow that the pleasures we enjoy are equivalent to our pains and cares: death therefore must be to us a relief from pain and misery, while to the brutes it is a privation of pleasure. Hence, if it be no positive evil for a brute to suffer death, to a

Hunting. man it must be a positive good: add to which, that a man lives in hope of an endless and glorious life, while a brute has no such hope; so that, if to kill a brute, on our author's principles, be no cruelty, to kill a man must be an act of tenderness and mercy!

Another argument, no less inconclusive, is our author's supposing that death from disease is much more to be dreaded in a brute than a violent death. Were brutes naturally in as helpless a state as man, no doubt their want of support from society in cases where they are attacked by sickness would be very deplorable; but it must be considered that the parallel betwixt the two species is in this respect by no means fair. A brute has everywhere its food at hand, and is naturally capable of resisting the inclemencies of the weather; but man has not only a natural inability to procure food for himself in the way that the brutes do, but is, besides, very tender and incapable of resisting the inclemency of the air. Hence, a man unassisted by society must very soon perish; and, no doubt, it would be much more merciful for people to kill one another at once, than to deprive them of the benefits of society, as is too frequently done in various ways needless to be mentioned at present. A brute, however, has nothing to fear. As long as its stomach can receive food, nature offers an abundant supply. One that feeds upon grass has it always within reach; and a carnivorous one will content itself with worms or insects, which, as long as it is able to crawl, it can still make a shift to provide; but so totally helpless is man when left to himself in a state of weakness, that many barbarous nations have looked upon the killing of their old and infirm people to be an act of mercy.

Equally unhappy is our author in his other arguments, that the quick transition from a state of perfect health to death mitigates the severity. The transition is not quick. The sportsmen estimate their diversion by the length of the chase; and during all that time the creature must be under the strongest agonies of terror; and what person of humanity is there who must not feel for an animal in this situation? All this is assented to by our author, who says, "Hard is the heart who does not commiserate the sufferer." Is not this an acknowledgment on his part, that before a person can become a thorough sportsman, he must harden his heart, and stifle those amiable sensations of compassion, which on all occasions ought to be encouraged towards every creature, unless in cases of necessity. But in the present case no necessity is or can be pretended. If a gentleman chooses to regale himself with venison of any kind, he may breed the animals for the purpose. We call Domitian cruel, because he took pleasure in catching flies, and stabbing them with a bodkin. A butcher is excluded from sitting on a jury on account of his being accustomed to sights which are deemed inhuman; but whether it is more inhuman to knock down an ox at once with an axe, or to tear him in pieces with dogs, (for they would accomplish the purpose if properly trained), must be left to the sportsmen to determine.

Lastly, the great argument in favour of hunting, that it contributes to the health of the body and exhilaration of the spirits, seems equally fallacious with the rest. It cannot be proved that hunters are more healthy or long-lived

Hunting. lived than other people. That exercise will contribute to the preservation of health, as well as to the exhilaration of the mind, is undoubted; but many other kinds of exercise will do this as well as hunting. A man may ride from morning to night, and amuse himself with viewing and making remarks on the country through which he passes; and surely there is no person will say that this exercise will tend to impair his health or sink his spirits. A man may amuse and exercise himself not only with pleasure, but profit also, in many different ways, and yet not accustom himself to behold the death of animals with indifference. It is this that constitutes the cruelty of hunting; because we thus wilfully extinguish in part that principle naturally implanted in our nature, which if totally eradicated would set us not only on a level with the most ferocious wild beasts, but perhaps considerably below them; and it must always be remembered, that whatever pleasure terminates in death is cruel, let us use as many palliatives as we please to hide that cruelty from the eyes of others, or even from our own.

The gentlemen and masters of the sport have invented a set of terms which may be called the *hunting-language*. The principal are those which follow:

1. For beasts as they are in company.—They say, a *herd* of harts, and all manner of deer. A *bevy* of roes. A *souder* of swine. A *roust* of wolves. A *richess* of martens. A *brace* or *leash* of bucks, foxes, or hares. A *couple* of rabbits or coney.

2. For their lodging.—A hart is said to *harbour*. A buck *lodges*. A roe *beds*. A hare *seats* or *forms*. A coney *sits*. A fox *kennels*. A marten *troes*. An otter *watches*. A badger *earths*. A boar *couches*.—Hence, to express their dislodging, they say, *Unharbour* the hart. *Rouse* the buck. *Start* the hare. *Bolt* the coney. *Unkennel* the fox. *Untree* the marten. *Vent* the otter. *Dig* the badger. *Rear* the boar.

3. For their noise at rutting time.—A hart *bellets*. A buck *growns* or *troats*. A roe *bellows*. A hare *beats* or *taps*. An otter *whines*. A boar *frames*. A fox *barks*. A badger *shrieks*. A wolf *howls*. A goat *rattles*.

4. For their copulation.—A hart or buck goes to *rut*. A roe goes to *tourne*. A boar goes to *brim*. A hare or coney goes to *buck*. A fox goes to *clickitting*. A wolf goes to *match* or *make*. An otter *hunteth* for his kind.

5. For the footing and treading.—Of a hart, we say the *slot*. Of a buck, and all fallow-deer, the *view*. Of all deer, if on the grass and scares visible, the *foiling*. Of a fox, the *print*; and of other the like vermin, the *footing*. Of an otter, the *marks*. Of a boar, the *track*. The hare when in open field, is said to *sore*; when she winds about to deceive the hounds, she *doubles*; when she beats on the hard highway, and her footing comes to be perceived, she *pricketh*: in snow, it is called the *trace* of the hare.

6. The tail of a hart, buck, or other deer, is called the *single*. That of a boar, the *wreath*. Of a fox, the *brush* or *drag*; and the tip at the end, the *chape*. Of a wolf, the *storn*. Of a hare and coney, the *scut*.

7. The ordure or excrement of a hart and all deer,

is called *ferments* or *fermishing*. Of a hare, *crotils* or *croting*. Of a boar, *leses*. Of a fox, the *billiding*; and of other the like vermin, the *fuants*. Of an otter, the *spraints*. **Hunting.**

8. As to the attire of deer, or parts thereof, those of a stag, if perfect, are the *bur*, the *pearls*, the little *knobs* on it, the *beam*, the *gutters*, the *antler*, the *sur-antler*, *royal*, *sur-royal*, and all at top the *croches*. Of the buck, the *bur*, *beam*, *brow-antler*, *black-antler*, *advancer*, *palm*, and *spellers*. If the croches grow in the form of a man's hand, it is called a *palmed head*. Heads bearing not above three or four, and the croches placed aloft, all of one height, are called *crowned heads*. Heads having double croches, are called *forked heads*, because the croches are planted on the top of the beam like forks.

9. They say, a *titter* of cubs, a *nest* of rabbits, a squirrel's *dray*.

10. The terms used in respect of the dogs, &c. are as follow.—Of grehounds, two make a *brace*; of hounds a *couple*. Of grehounds, three make a *leash*; of hounds, a *couple* and *half*.—They say, *let slip* a grehound; and, *cast off* a hound. The string wherein a grehound is led, is called a *leash*; and that of a hound, a *lyome*. The grehound has his *collar*, and the hound his *couplets*. We say a *kennel* of hounds, and a *pack* of beagles.

HUNTING, as practised among us, is chiefly performed with dogs; of which we have various kinds, accommodated to the various kinds of game, as, *hounds*, *grehounds*, *bloodhounds*, *terriers*, &c. See CANIS, HOUND, &c.

In the kennels or packs they generally rank them under the heads of *enterers*, *drivers*, *flyers*, *tyers*, &c.

On some occasions, nets, spears, and instruments for digging the ground, are also required: nor is the hunting horn to be omitted.

The usual chases among us are, the *hart*, *buck*, *roe*, *hare*, *fox*, *badger*, and *otter*.—We shall here give something of what relates to each thereof: first premising an explanation of some general terms and phrases, more immediately used in the progress of the sport itself; what belongs to the several sorts of game in particular being reserved for the respective articles.

When the hounds, then, being cast off, and finding the scent of some game, begin to open and cry; they are said to *challenge*. When they are too busy ere the scent be good, they are said to *babble*. When too busy where the scent is good, to *bevol*. When they run it endwise orderly, holding in together merrily, and making it good, they are said to be in *full cry*. When they run along without opening at all, it is called *running mute*.

When spaniels open in the string, or a grehound in the course, they are said to *lapse*.

When beagles bark and cry at their prey, they are said to *yaarn*.

When the dogs hit the scent the contrary way, they are said to *draw amiss*.

When they take fresh scent, and quit the former chase for a new one, it is called *hunting change*.

When they *hunt* the game by the heel or track, they are said to *hunt counter*.

When

Hunting.

When the chase goes off, and returns again, traversing the same ground, it is called *hunting the foil*.

When the dogs run at a whole herd of deer, instead of a single one, it is called *running riot*.

Dogs set in readiness where the game is expected to come by, and cast off after the other hounds are passed, are called a *relay*. If they be cast off ere the other dogs be come up, it is called *vauntlay*.

When, finding where the chase has been, they make a proffer to enter, but return, it is called a *blemish*.

A lesson on the horn to encourage the hounds, is named a *call*, or a *recheat*. That blown at the death of a deer, is called the *mort*. The part belonging to the dogs of any chase they have killed, is the *reward*. They say, *take off* a deer's skin; *strip* or *case* a hare, fox, and all sorts of vermin; which is done by beginning at the snout, and turning the skin over the ears down to the tail.

HUNTING is practised in a different manner, and with different apparatus, according to the nature of the beasts which are hunted, a description of which may be found under their respective articles, *infra*.

With regard to the seasons, that for hart and buck-hunting begins a fortnight after midsummer, and lasts till Holy-rod day; that for the hind and doe, begins on Holy-rod day, and lasts till Candlemas; that for fox-hunting begins at Christmas, and holds till Lady-day; that for roe-hunting begins at Michaelmas, and ends at Christmas; hare-hunting commences at Michaelmas, and lasts till the end of February; and where the wolf and boar are hunted, the season for each begins at Christmas, the first ending at Lady-day, and the latter at the Purification.

When the sportsmen have provided themselves with nets, spears, and a hunting horn to call the dogs together, and likewise with instruments for digging the ground, the following directions will be of use to them in the pursuit of each sort of game.

Badger-HUNTING. In doing this, you must seek the earths and burrows where he lies, and in a clear moonshine night go and stop all the burrows, except one or two, and therein place some sacks, fastened with drawing strings, which may shut him in as soon as he straineth the bag. Some use no more than to set a hoop in the mouth of the sack, and so put it into the hole; and as soon as the badger is in the sack and straineth it, the sack slippeth off the hoop, and follows him to the earth, so he lies tumbling therein till he is taken. These sacks or bags being thus set, cast off the hounds, beating about all the woods, coppices, hedges, and tufts, round about, for the compass of a mile or two; and what badgers are abroad, being alarmed by the hounds, will soon betake themselves to their burrows; and observe, that he who is placed to watch the sacks, must stand close and upon a clear wind: otherwise the badger will discover him, and will immediately fly some other way into his burrow. But if the hounds can encounter him before he can take his sanctuary, he will then stand at a bay like a boar, and make good sport, grievously biting and clawing the dogs; for the manner of their fighting is lying on their backs, using both teeth and nails; and by blowing up their skins, defend themselves against all bites of the dogs, and blows of the men upon their noses. And for the better preservation of your dogs, it is good

to put broad collars about their necks made of gray Hunting skins.

When the badger perceives the terriers to begin to yearn him in his burrow, he will stop the hole betwixt him and the terriers, and if they still continue baying, he will remove his couch into another chamber or part of the burrow, and so from one into another, barricading the way before them, as they retreat, until they can go no further. If you intend to dig the badger out of his burrow, you must be provided with the same tools as for digging out a fox; and besides, you should have a pail of water to refresh the terriers, when they come out of the earth to take breath and cool themselves. It will also be necessary to put collars of bells about the necks of your terriers, which making a noise may cause the badger to bolt out. The tools used for digging out of the badger, being troublesome to be carried on men's backs, may be brought in a cart. In digging, you must consider the situation of the ground, by which you may judge where the chief angles are; for else, instead of advancing the work, you will hinder it. In this order you may besiege them in their folds, or castles; and may break their platforms, parapets, casements, and work to them with mines and countermines until you have overcome them.

Having taken a live and lusty badger, if you would make sport, carry him home in a sack and turn him out in your court-yard, or some other enclosed place, and there let him be hunted and worried to death by your hounds.

There are the following profits and advantages which accrue, by killing this animal. Their flesh, blood, and grease, though they are not good food, yet are very useful for physicians and apothecaries for oils, ointments, salves, and powders for shortness of breath, the cough of the lungs, for the stone, sprained sinews, colic-aches, &c.; and the skin being well dressed, is very warm and good for old people who are troubled with paralytic distempers.

Boar-HUNTING. See BOAR.

Buck-HUNTING. Here the same hounds and methods are used as in running the stag; and, indeed, he that can hunt a hart or stag well, will not hunt a buck ill.

In order to facilitate the chase, the game-keeper commonly selects a fat buck out of the herd, which he shoots in order to maim him, and then he is run down by the hounds.

As to the method of hunting the buck. The company generally go out very early for the benefit of the morning. Sometimes they have a deer ready lodged; if not, the coverts are drawn till one is roused: or sometimes in a park a deer is pitched upon, and forced from the herd, then more hounds are laid on to run the chase. If you come to be at a fault, the old staunch hounds are only to be relied upon till you recover him again: if he be sunk, and the hounds thrust him up, it is called an *imprime*, and the company all sound a recheat; when he is run down, every one strives to get in to prevent his being torn by the hounds, fallow deer seldom or never standing at bay.

He that first gets in, cries hoo-up, to give notice that he is down, and blows a death. When the company are all come in, they paunch him, and reward the hounds, and generally the chief person of quality amongst them *takes say*, that is, cuts his belly open, to see how fat he

is. When this is done, every one has a chop at his neck, and the head being cut off is shewed to the hounds, to encourage them to run only at a male deer, which they see by the horns, and to teach them to bite only at the head: then the company all standing in a ring, one blows a single death; which being done, all blow a double reheat, and so conclude the chase with a general halloo of hoo-up, and depart the field to their several homes, or to the place of meeting; and the huntsman, or some other, hath the deer cast across the buttocks of his horse, and so carries him home.

Fox-HUNTING makes a very pleasant exercise, and is either above or below ground.

1. *Above ground.* To hunt a fox with hounds, you must draw about groves, thickets, and bushes, near villages. When you find one, it will be necessary to stop up the earth, the night before you design to hunt, and that about midnight; at which time he is gone out to prey: this may be done by laying two white sticks across in his way, which he will imagine to be some gin or trap laid for him; or else they may be stopped up with black thorns and earth mixed together.

Mr Beckford is of opinion that for fox-hunting the pack should consist of 25 couple. The hour most favourable for the diversion is an early one; and he thinks that the hounds should be at the cover at sun-rising. The huntsman should then throw in his hounds as quickly as he can, and let the two whippers in keep wide of him on either hand; so that a single hound may not escape them; let them be attentive to his halloo, and let the sportsmen be ready to encourage or rate as that directs. The fox ought on no account to be hallooed too soon, as in that case he would most certainly turn back again, and, spoil all the sport.—Two things our author particularly recommends, viz. the making all the hounds steady, and making them all draw. “Many huntsmen (says he) are fond of having them at their horse’s heels; but they never can get so well or so soon together as when they spread the cover; besides, I have often known where there have been only a few finders, that they have found their fox gone down the wind, and been heard of no more that day. Much depends upon the first finding your fox; for I look upon a fox well found to be half killed. I think people are generally in too great a hurry on this occasion. There are but few instances where sportsmen are not too noisy, and too fond of encouraging their hounds, which seldom do their business so well as when little is said to them. The huntsman ought certainly to begin with his foremost hounds; and I should wish him to keep as close to them as he conveniently can; nor can any harm arise from it, unless he should not have common sense. No hounds can then slip down the wind and get out of his hearing; he will also see how far they carry a scent, a necessary requisite; for without it he never can make a cast with any certainty.—You will find it not less necessary for your huntsman to be active in pressing forward his hounds when the scent is good, than to be prudent in not hurrying them beyond it when it is bad. It is his business to be ready at all times to lend them that assistance which they so frequently need, and which when they are first at a fault is then most critical. A fox-hound at that time will exert himself most; he afterwards cools and becomes most indifferent about his game. Those huntsmen who

do not get forward enough to take advantage of this eagerness and impetuosity, and direct it properly, seldom know enough of hunting to be of much use to them afterwards. Though a huntsman cannot be too fond of hunting, a whipper-in easily may. His business will seldom allow him to be forward enough with the hounds to see much of the sport. His only thought therefore should be to keep the hounds together, and to contribute as much as he can to the killing of the fox: keeping the hounds together is the surest means to make them steady. When left to themselves they seldom refuse any blood they can get; they become conceited; learn to tie upon the scent; and besides this they frequently get a trick of hunting by themselves, and are seldom good for much afterwards.

“Every country is soon known; and nine foxes out of ten, with the wind in the same quarter, will follow the same track. It is therefore easy for the whipper-in to cut short, and catch the hounds again. With a high scent you cannot push on hounds too much. Screams keep the fox forward, at the same time that they keep the hounds together, or let in the tail-hounds: they also enliven the sport; and, if discreetly used, are always of service; but in cover they should be given with the greatest caution. Halloos seldom do any hurt when you are running up the wind, for then none but the tail hounds can hear you: when you are running down the wind, you should halloo no more than may be necessary to bring the tail hounds forward; for a hound that knows his business seldom wants encouragement when he is upon a scent.—Most fox-hunters wish to see their hounds run in a *good style*. I confess I myself am one of those; I hate to see a string of them; nor can I bear to see them creep where they can leap. A pack of harriers, if they have time, may kill a fox, but I defy them to kill him in the style in which he ought to be killed; they must hunt him down. If you intend to tire him out, you must expect to be tired also yourself; I never wish a chase to be less than one hour, or to exceed two: It is sufficiently long if properly followed: it will seldom be longer unless there be a fault somewhere either in the day, the huntman, or the hounds.

“Changing from the hunted fox to a fresh one is as bad an accident as can happen to a pack of fox-hounds, and requires all the ingenuity and observation that man is capable of to guard against it. Could a fox-hound distinguish a hunted fox as the deer-hound does the deer that is blown, fox-hunting would then be perfect. A huntsman should always listen to his hounds while they are running in cover; he should be particularly attentive to the headmost hounds, and he should be constantly on his guard against a skirter: for if there be two scents, he must be wrong. Generally speaking, the best scent is least likely to be that of the hunted fox: and as a fox seldom suffers hounds to run up to him as long as he is able to prevent it; so, nine times out of ten, when foxes are hallooed early in the day, they are all fresh foxes. The hounds most likely to be right are the hard-running line-hunting ones; or such as the huntsman knows had the lead before there arose any doubt of changing. With regard to the fox, if he break over an open country, it is no sign that he is hard run; for they seldom at any time will do that unless they are a great way before the hounds. Also if he run

Hunting. up the wind; they seldom or never do that when they have been long hunted and grow weak; and when they turn their foil, that also may direct him. All this requires a good ear and nice observation; and indeed in that consists the chief excellence of a huntsman.

"When the hounds divide, and are in two parts, the whipper-in, in stopping, must attend to the huntsman and wait for his halloo, before he attempts to stop either: for want of proper management in this respect, I have known the hounds stopped at both places, and both foxes lost. If they have many scents, and it is quite uncertain which is the hunted fox, let him stop those that are farthest down the wind; as they can hear the others, and will reach them soonest: in such a case there will be little use in stopping those that are up the wind. When hounds are at a check, let every one be silent and stand still. Whippers-in are frequently at this time coming on with the tail hounds. They should never halloo to them when the hounds are at fault; the least thing does them harm at such a time, but a halloo more than any other. The huntsman, at a check, had better let his hounds alone; or content himself with holding them forward, without taking them off their noses.—Should they be at a fault, after having made their own cast (which the huntsman should always first encourage them to do), it is then his business to assist them further; but except in some particular instances, I never approve of their being cast as long as they are inclined to hunt. The first cast I bid my huntsman make it generally a regular one, not choosing to rely entirely on his judgment: if that should not succeed, he is then at liberty to follow his own opinion, and proceed as observation or genius may direct. When such a cast is made, I like to see some mark of good sense and meaning in it; whether down the wind, or towards some likely cover or strong earth. However, as it is at best uncertain, I always wish to see a regular cast before I see a knowing one; which, as a last resource, should not be called forth till it be wanted: The letting hounds alone is but a negative goodness in a huntsman; whereas it is true this last shows real genius; and to be perfect it must be born with him. There is a fault, however, which a knowing huntsman is too apt to commit: he will find a fresh fox, and then claim the merit of having recovered the hunted one. It is always dangerous to throw hounds into a cover to retrieve a lost scent; and unless they hit him in, is not to be depended on.

"Gentlemen, when hounds are at fault, are too apt themselves to prolong it. They should always stop their horses some distance behind the hounds; and if it be possible to remain silent, this is the time to be so. They should be careful not to ride before the hounds or over the scent; nor should they ever meet a hound in the face, unless with a design to stop him. Should you at any time be before the hounds, turn your horse's head the way they are going, get out of their track, and let them pass by you. In dry weather, and particularly in heathy countries, foxes will run the roads. If gentlemen at such times will ride close upon the hounds, they may drive them miles without any scent.—High-mettled fox-hounds are seldom inclined to stop while horses are close at their heels. No one should ever ride in a direction which if persisted in would

carry him amongst the hounds, unless he be at a great distance behind them.

"The first moment that hounds are at fault is a critical one for the sport people, who should then be very attentive. Those who look forward may perhaps see the fox; or the running of sheep, or the pursuit of crows, may give them some tidings of him. Those who listen may sometimes get a hint which way he is gone from the clattering of a magpie; or perhaps be at a certainty from a distant halloo: nothing that can give any intelligence at such a time ought to be neglected. Gentlemen are too apt to ride all together: were they to spread more, they might sometimes be of service; particularly those who, from a knowledge of the sport, keep down the wind: it would then be difficult for either hounds or fox to escape their observation.—You should, however, be cautious how you go to a halloo. The halloo itself must in a great measure direct you; and though it afford no certain rule, yet you may frequently guess whether it can be depended upon or not. At the sowing time, when boys are keeping off the birds, you will sometimes be deceived by their halloos; so that it is best, when you are in doubt, to send a whipper-in to know the certainty of the matter."

Hounds ought not to be cast as long as they are able to hunt. It is a common, though not very just idea, that a hunted fox never stops; but our author informs us that he has known them stop even in wheel-ruts in the middle of a down, and get up in the middle of the hounds. The greatest danger of losing a fox is at the first finding him, and when he is sinking; at both which times he frequently will run short, and the eagerness of the hounds will frequently carry them beyond the scent. When a fox is first found, every one ought to keep behind the hounds till they are well settled on the scent; and when the hounds are catching him, our author wishes them to be as silent as possible; and likewise to eat him eagerly after he is caught. In some places they have a method of *treecing* him; that is, throwing him across the branch of a tree, and suffering the hounds to bay at him for some minutes before he is thrown among them; the intention of which is to make them more eager, and to let in the tail hounds; during this interval also they recover their wind, and are apt to eat him more readily. Our author, however, advises not to keep him too long, as he supposes that the hounds have not any appetite to eat him longer than while they are angry with him.

2. *Under-ground.* In case a fox does so far escape as to earth, countrymen must be got together with shovels, spades, mattocks, pick-axes, &c. to dig him out, if they think the earth not too great. They make their earths as near as they can in ground that is hard to dig, as in clay, stony ground, or amongst the roots of trees; and their earths have commonly but one hole, and that is straight a long way in before you come at their couch. Sometimes craftily they take possession of a badger's old burrow, which hath a variety of chambers, holes, and angles.

Now to facilitate this way of hunting the fox, the huntsman must be provided with one or two terriers to put into the earth after him, that is, to fix him into an angle; for the earth often consists of many angles: the

use

Hunting. use of the terrier is to know where he lies; for as soon as he finds him, he continues baying or barking, so that which way the noise is heard that way dig to him. Your terriers must be garnished with bells hung in collars, to make the fox belt the sooner; besides, the collars will be some small defence to the terriers.

The instruments to dig withal are these; a sharp-pointed spade, which serves to begin the trench where the ground is hardest and broader tools will not so well enter; the round hollowed spade, which is useful to dig among roots, having very sharp edges; the broad flat spade to dig withal, when the trench has been pretty well opened, and the ground softer; mattocks and pick-axes to dig in hard ground, where a spade will do but little service; the coal-rake to cleanse the hole, and to keep it from stopping up; clamps, wherewith you may take either fox or badger out alive to make sport with afterwards. And it would be very convenient to have a pail of water to refresh your terriers with, after they are come out of the earth to take breath.

Hare-HUNTING. As, of all chases, the hare makes the greatest pastime, so it gives no little pleasure to see the craft of this small animal for her self-preservation. If it be rainy, the hare usually takes to the high-ways; and if she come to the side of a young grove, or spring, she seldom enters, but squats down till the hounds have over-shot her; and then she will return the very way she came, for fear of the wet and dew that hangs on the boughs. In this case, the huntsman ought to stay a hundred paces before he comes to the wood-side, by which means he will perceive whether she return as aforesaid; which if she do, he must halloo in his hounds; and call them back; and that presently, that the hounds may not think it the counter she came first.

The next thing that is to be observed, is the place where the hare sits, and upon what wind she makes her form, either upon the north or south wind: she will not willingly run into the wind, but run upon a side, or down the wind; but if she form in the water, it is a sign she is foul and meased: if you hunt such a one, have a special regard all the day to the brook-sides; for there, and near plashes, she will make all her crossings, doublings, &c.

Some hares have been so crafty, that as soon as they have heard the sound of a horn, they would instantly start out of their form, though it was at the distance of a quarter of a mile, and go and swim in some pool, and rest upon some rush bed in the midst of it; and would not stir from thence till they have heard the sound of the horn again, and then have started out again, swimming to land, and have stood up before the hounds four hours before they could kill them, swimming and using all subtilities and crossings in the water. Nay, such is the natural craft and subtilty of a hare, that sometimes after she has been hunted three hours, she will start a fresh hare, and squat in the same form. Others having been hunted a considerable time, will creep under the door of a sheep cot, and hide themselves among the sheep; or, when they have been hard hunted, will run in among a flock of sheep, and will by no means be gotten out from among them till the hounds are coupled up, and the sheep driven into their pens. Some of them (and that seems somewhat strange

Hunting. will take the ground like a coney, and that is called *going to the vault*. Some hares will go up one side of the hedge, and come down the other, the thickness of the hedge being the only distance between the courses. A hare that has been sorely hunted, has got upon a quickset hedge, and run a good way upon the top thereof, and then leapt off upon the ground. And they will frequently betake themselves to furze bushes, and will leap from one to the other, whereby the hounds are frequently in default.

Having found where a hare hath relieved in some pasture or corn-field, you must then consider the season of the year, and what weather it is: for if it be in the spring-time, or summer, a hare will not then set in bushes, because they are frequently infested with pis-mires, snakes, and adders; but will set in corn-fields, and open places. In the winter-time, they set near towns and villages, in tufts of thorns and brambles, especially when the wind is northerly or southerly. According to the season and nature of the place where the hare is accustomed to sit, there beat with your hounds, and start her; which is much better sport than trailing of her from her relief to her form.

After the hare has been started and is on foot, then step in where you saw her pass, and halloo in your hounds, until they have all undertaken it and go on with it in full cry: then recbeat to them with your horn, following fair and softly at first, making not too much noise either with horn or voice; for at the first, hounds are apt to overshoot the chase through too much heat. But when they have run the space of an hour, and you see the hounds are well in with it, and stiek well upon it, then you may come in nearer with the hounds, because by that time their heat will be cooled, and they will hunt more soberly. But above all things, mark the first doubling, which must be your direction for the whole day; for all the doublings that she shall make afterwards will be like the former; and according to the policies that you shall see her use, and the place where you hunt, you must make your compasses great or little, long or short, to help the defaults, always seeking the moitest and most commodious places for the hounds to scent in.

To conclude: Those who delight in hunting the hare must rise early, lest they be deprived of the scent of her footsteps.

Hart or Stag HUNTING. Gesner, speaking of hart-hunting, observes, that this wild, deceitful, and subtle beast, frequently deceives its hunter by windings and turnings. Wherefore the prudent hunter must train his dogs with words of art, that he may be able to set them on and take them off again at pleasure.

First of all, he should encompass the beast in her own layer, and so unharbour her in the view of the dogs, that so they may never lose her slot or footing. Neither must he set upon every one, either of the herd or those that wander solitary alone, or a little one; but partly by sight, and partly by their footing and fumets, make a judgment of the game, and also observe the largeness of his layer.

The huntsman, having made these discoveries in order to the chase, takes off the couplings of the dogs; and some on horseback, others on foot, follow the cry, with the greatest art, observation, and speed; remembering and intercepting him in his subtle turnings and

Hunting. headings; with all agility leaping hedges, gates, pales, ditches; neither fearing thorns, down-hills, nor woods, but mounting a fresh horse if the first tire. Follow the largest head of the whole herd, which must be singled out of the chase; which the dogs perceiving, must follow; not following any other. The dogs are animated to the sport by the winding of horns, and the voices of the huntsmen. But sometimes the crafty beast sends forth his little squire to be sacrificed to the dogs and hunters, instead of himself, lying close the mean time. In this case, the huntsman must sound a retreat, break off the dogs, and take them in, that is, leam them again, until they be brought to the fairer game; which riseth with fear, yet still striveth by flight, until he be wearied and breathless. The nobles call the beast a *wise hurt*, who, to avoid all his enemies, runneth into the greatest herds, and so brings a cloud of error on the dogs, to obstruct their further pursuit; sometimes also bearing some of the herd into his footings, that so he may the more easily escape by amusing the dogs. Afterwards he betakes himself to his heels again, still running with the wind, not only for the sake of refreshment, but also because by that means he can the more easily hear the voice of his pursuers whether they be far from him or near to him. But at last being again discovered by the hunters and sagacious scent of the dogs, he flies into the herds of cattle, as cows, sheep, &c. leaping on a cow or ox, laying the fore parts of his body thereon, that so touching the earth only with his hinder feet, he may leave a very small or no scent at all behind for the hounds to discern. But their usual manner is, when they see themselves hard beset and every way intercepted, to make force at their enemy with their horns, who first comes upon him, unless they be prevented by spear or sword. When the beast is slain, the huntsman with his horn windeth the fall of the beast; and then the whole company comes up, blowing their horns in triumph for such a conquest; among whom, the skillfullest opens the beast, and rewards the hounds with what properly belongs to them, for their future encouragement; for which purpose the huntsmen dip bread in the skin and blood of the beast to give to the hounds.

It is very dangerous to go in to a hart at bay; of which there are two sorts, one on land and the other in water. Now, if the hart be in a deep water, where you cannot well come at him, then couple up your dogs; for should they continue long in the water, it would endanger their surbating or foundering. In this case, get a boat, and swim to him, with dagger drawn, or else with rope that has a noose, and throw it over his horns: for if the water be so deep that the hart swims, there is no danger in approaching him; otherwise you must be very cautious.

As to the land-bay, if a hart be burnished, then you must consider the place; for if it be in a plain and open place, where there is no wood nor covert, it is dangerous and difficult to come in to him; but if he be on a hedge-side, or in a thicket, then, while the hart is staring on the hounds, you may come softly and covertly behind him, and cut his throat. If you miss your aim, and the hart turn head upon you, then take refuge at some tree; and when the hart is at bay, couple up your hounds; and when you see the hart turn head to

fly, gallop in roundly to him, and kill him with your sword.

Directions at the Death of a Hart or Buck. The first ceremony, when the huntsman comes in to the death of a deer, is to cry "ware haunch," that the hounds may not break into the deer; which being done, the next is the cutting his throat, and there blooding the youngest hounds, that they may the better love a deer, and learn to leap at his throat: then the mort having been blown, and all the company come in, the best person who hath not taken say before, is to take up the knife that the keeper or huntsman is to lay across the belly of the deer, some holding by the fore legs, and the keeper or huntsman drawing down the pizzle, the person who takes say, is to draw the edge of the knife leisurely along the middle of the belly, beginning near the brisket, and drawing a little upon it, enough in the length and depth to discover how fat the deer is; then he that is to break up the deer, first slits the skin from the cutting of the throat downward, making the arber, that so the ordure may not break forth, and then he paunches him, rewarding the hounds with it.

In the next place, he is to present the same person who took say, with a drawn hanger, to cut off the head of the deer. Which being done, and the hounds rewarded, the concluding ceremony is, if it be a stag, to blow a triple mort; and if a buck, a double one; and then all who have horns, blow a recheat in concert, and immediately a general whoop, whoop.

Otter-HUNTING is performed with dogs, and also with a sort of instruments called *otter-spears*; with which when they find themselves wounded, they make to land, and fight with the dogs, and that most furiously, as if they were sensible that cold water would annoy their green wounds.

There is indeed craft to be used in hunting them; but they may be caught in snares under water, and by river-sides: but great care must be taken, for they bite sorely and venomously; and if they happen to remain long in the snare, they will not fail to get themselves free by their teeth.

In hunting them, one man must be on one side of the river, and another on the other, both beating the banks with dogs; and the beast not being able to endure the water long, you will soon discover if there be an otter or not in that quarter; for he must come out to make his sprainte, and in the night sometimes to feed on grass and herbs.

If any of the hounds finds out an otter, then view the soft grounds and moist places, to find out which way he bent his head; if you cannot discover this by the marks, you may partly perceive it by the spraints; and then follow the hounds, and lodge him as a hart or deer. But if you do not find him quickly, you may imagine he is gone to couch somewhere farther off from the river; for sometimes they will go to feed a considerable way from the place of their rest, choosing rather to go up the river than down it. The persons that go a-hunting otters, must carry their spears, to watch his vents, that being the chief advantage; and if they perceive him swimming under water, they must endeavour to strike him with their spears, and if they miss, must pursue him with the hounds, which, if they be good and perfectly entered, will go chanting

Hunting. ing and travelling along by the river-side, and will beat every root of a tree, and osier-bed, and tuft of bulrushes; nay, they will sometimes take water, and bait the beast, like a spaniel, by which means he will hardly escape.

Roe-buck HUNTING is performed divers ways, and very easily in the woods.

When chased, they usually run against the wind, because the coolness of the air refreshes them in their course; therefore the huntsmen place their dogs with the wind: they usually, when hunted, first take a large ring, and afterwards hunt the hounds. They are also often taken by counterfeiting their voice, which a skilful huntsman knows how to do by means of a leaf in his mouth. When they are hunted, they turn much and often, and come back upon the dogs directly; and when they can no longer endure, they take foil, as the hart does, and will hang by a bough in such a manner, that nothing of them shall appear above the water but their snout, and they will suffer the dogs to come just upon them before they will stir.

The venison of a roe-buck is never out of season, being never fat, and therefore they are hunted at any time; only that some favour ought to be shown the doe while she is big with fawn, and afterwards till her fawn is able to shift for himself; but some roe-does have been killed with five fawns in their bellies.

He is not called, by the skilful in the art of hunting, a *great* roe-buck, but a *fair* roe-buck; the herd of them is called a *bevy*: and if he hath not bevy-grease upon his tail, when he is broken up, he is more fit to be dog's meat than man's meat. The hounds must be rewarded with the bowels, the blood, and feet slit asunder, and boiled altogether; this is more properly called a *doss* than a *reward*.

HUNTING-Match. The first thing that is to be considered by one who designs to match his horse for his own advantage, and his horse's credit, is not to flatter himself with the opinion of his horse, by fancying that he is a swift, when he is but a slow galloper; and that he is a whole-running-horse, that is, that he will run four miles without a sob at the height of his speed, when he is not able to run two or three. Very probably some gentlemen are led into this error, by their being mistaken in the speed of their hounds, who for want of trying them against other dogs that have been really fleet, have supposed their own to be so, when in reality they are but of a middling speed; and because their horse, when trained, was able to follow them all day, and upon any hour, to command them upon deep as well as light earths, have therefore made a false conclusion, that their horse is as swift as the best; but, upon trial against a horse that has been rightly trained after hounds that were truly fleet, have bought their experience perhaps full dear. Therefore it is advisable for all lovers of hunting to procure two or three couple of tried hounds, and once or twice a-week to follow after them at train-scent; and when he is able to top them on all sorts of earth, and to endure heats and colds stoutly, then he may better rely on his speed and toughness.

That horse which is able to perform a hare-chase of five or six miles briskly and courageously, till his body be as it were bathed in sweat; and then, after the

hare has been killed, in a nipping frosty morning, can endure to stand till the sweat be frozen on his back, so that he can endure to be pierced with the cold as well as the heat; and then, even in that extremity of cold, to ride another chase as briskly, and with as much courage as he did the former; that horse which can thus endure heats and colds is most valued by sportsmen. Therefore in order to make a judgment of the goodness of a horse, observe him after the death of the first hare, if the chase has been any thing brisk: if, when he is cold, he shrinks up his body, and draws his legs up together, it is an infallible sign of want of vigour and courage: the like may be done by the slackening of his girths after the first chase, and from the dulness of his teeth, and the dulness of his countenance, all which are true tokens of faintness and being tired; and such a horse is not to be relied on in case of a wager.

Here it will not be improper to take notice of the way of making matches in former times, and the modern way of deciding wagers. The old way of trial was, by running so many train-scents after hounds, as was agreed upon between the parties concerned, and a bell-course, this being found not so uncertain, but more durable than hare-hunting; and the advantage consisted in having the trains led on earth most suitable to the qualifications of the horses. But now others choose to hunt the hare till such an hour, and then to run this wild-goose chase; a method of racing that takes its name from the manner of the flight of wild geese, which is generally one after another; so the two horses after running of twelvescore yards, had liberty, which horse soever could get the leading, to ride what ground he pleased, the hindmost horse being bound to follow him, within a certain distance agreed on by articles, or else to be whipped up by the triers or judges which rode by; and whichever horse could distance the other won the match.

But this chase, in itself very inhuman, was soon found to be very destructive to good horses, especially when two good horses were matched; for neither being able to distance the other till both were ready to sink under their riders through weakness, oftentimes the match was fain to be drawn and left undecided, though both the horses were quite spoiled.

This brought up the custom of train-scents, which afterwards was changed to three heats and a straight course; and that the lovers of horses might be encouraged to keep good ones, plates have been erected in many places in Britain. The fewer of these before you come to the course, if your horse be fiery and mettled, the better; and the shorter the distance, the better. Also, above all things, be sure to make your bargain to have the leading of the first train; and then make choice of such grounds where your horse may best show his speed, and the fleetest dogs you can procure: give your hounds as much law before you as your triers will allow, and then making a loose, try to win the match with a wind; but if you fail in this attempt, then bear your horse, and save him for the course; but if your horse be slow, but well-winded, and a true spurred nag, then the more train-scents you run before you come to the straight-course, the better. But here you ought to observe to gain the leading of the first train; which in this case you must lead.

Hunting.

Hunting

Hu-quang

lead upon such deep earths, that it may not end near any light ground: for this is the rule received among horsemen, that the next train is to begin where the last ends, and the last train is to be ended at the starting place of the course; therefore remember to end your last on deep earths, as well as the first.

HUNTINGDON, the county-town of Huntingdonshire in England, seated upon an easy ascent, on the north side of the river Ouse. It was made a free borough by King John, consisting of a mayor, 12 aldermen, burgesses, &c. by whom the two members of parliament are chosen. It had anciently 15 parishes, and has now but two; in one of which, called *St John's*, Oliver Cromwell was born, in 1599. Here was formerly a castle, built by William the Conqueror, which afterwards belonged to David, a prince of Scotland, with the title of *earl*; but Henry VIII. gave it to George Hastings, with the earldom annexed, in whose family it still continues. It stands on the great north road; and has a bridge built of free-stone over the Ouse, which is made navigable for small vessels as high as Bedford. It is the place where the assizes are kept, and where the county-jail stands. It has a good market-place, and several convenient inns, besides a grammar-school, and contained 2397 inhabitants in 1811. W. Long. o. 11. N. Lat. 52. 17.

HUNTINGDONSHIRE, a county of England, bounded on the south by Bedfordshire; on the west by Northamptonshire, as also on the north; and by Cambridgeshire on the east; extending 26 miles in length from north to south, 20 in breadth from east to west, and nearly 67 in circumference. This county, which is in the diocese of Lincoln, is divided into four hundreds, and contains 6 market-towns, 29 vicarages, 78 parishes, 256 villages, about 6841 houses, and in 1811, 42,208 inhabitants; but sends only four members to parliament, namely, two knights of the shire, and two members for Huntingdon. It is a good corn country; and abounds in pastures, especially on the eastern side, which is feony. The rest is diversified by rising hills and shady groves, and the river Ouse waters the southern part.

The air of this county is in most parts pleasant and wholesome, except among the fens and meres, though they are not so bad as the hundreds of Kent and Essex. The soil is fruitful, and produces great crops of corn, and the hilly parts afford a fit pasture for sheep. They have great numbers of cattle; and plenty of water-fowl, fish, and turf for firing; which last is of great service to the inhabitants, there being but little wood, though the whole county was a forest in the time of Henry II. The only river besides the Ouse is the Nen, which runs through Whittlesey mere.

HU-QUANG, a province of the kingdom of China, in Asia, which has a great river called *Yang*, and *Tse-chiang*, which runs across it from east to west. It is divided into the north and south parts, the former of which contains eight cities of the first rank, and 60 of the second and third; and the latter, seven of the first rank, and five of the second and third. It is a flat, open country, watered everywhere with brooks, lakes, and rivers, in which there are great numbers of fish. Here is plenty of wild-fowls; the fields nourish cattle without number, and the soil produces corn, and various kinds of fruits. There is gold found in the

sands of the rivers; and in the mines they have iron, tin, &c. In short, there is such a variety of all sorts of commodities, that it is called *the magazine of the empire*. Hu-quang

Hurricane

HURA, in *Botany*, a genus of plants belonging to the monœcia class; and in the natural method ranking under the 38th order, *Tricocœa*. See **BOTANY Index**.

HURDLE, is the name of a sledge used to draw traitors to the place of execution.

HURDLES, in *Fortification*, are made of twigs of willows or osiers interwoven close together, sustained by long stakes. They are made in the figure of a long square, the length being five or six feet, and the breadth three and a half. The closer they are wattled together, the better. They serve to render the batteries firm, or to consolidate the passage over muddy ditches; or to cover traverses and lodgments for the defence of the workmen against fire-works or stones thrown against them.

The Romans had a kind of military execution for mutineers, called *putting to death under the hurdle*. The manner of it was this: The criminal was laid at his length in a shallow water, under an hurdle, upon which was heaped stones, and so pressed down till he was drowned.

HURDLES, in *Husbandry*, certain frames made either of split timber, or of hazel-rods wattled together, to serve for gates in inclosures, or to make sheep-folds, &c.

HURDS, or **HORDS**, of flax or hemp; the coarser parts separated in the dressings from the tear, or fine stuff. See **FLAX**.

HURL-BONE, in a horse, a bone near the middle of the buttock, very apt to go out of its sockets with a hurt or strain.

HURLERS, a number of large stones, set in a kind of square figure near St Clare in Cornwall, so called from an odd opinion held by the common people, that they are so many men petrified, or changed into stones, for profaning the sabbath-day by hurling the ball, an exercise for which the people of that country have been always famous.

The hurlers are oblong, rude, and unhewed. Many authors suppose them to have been trophies erected in memory of some battle: others take them for boundaries to distinguish lands. Lastly, others, with more probability, hold them to have been sepulchral monuments.

HURLY-BURLY, in vulgar language, denotes confusion or tumult, and is said to owe its origin to two neighbouring families, Hurleigh and Burleigh, which filled their part of the kingdom with contest and violence.

HURON, a vast lake of North America, situated between 80° and 84° W. Long. and between 43° and 46° of N. Lat. from whence the country contiguous to it is called *the country of the Hurons*, whose language is spoken over a great extent in the southern parts of America.

HURRICANE, a general name for any violent storm of wind; but which is commonly applied to those storms which happen in the warmer climates, and which greatly exceed the most violent storms known in this country. The ruin and desolation accompany-

Hurricane ing a hurricane (says Dr Mosely*) cannot be described. Like fire, its resistless force consumes every thing in its track, in the most terrible and rapid manner. It is generally preceded by an awful stillness of the elements, and a closeness and mistiness in the atmosphere, which makes the sun appear red, and the stars larger. But a dreadful reverse succeeding—The sky is suddenly overcast and wild—The sea rises at once from a profound calm into mountains—The wind rages and roars like the noise of cannon—The rain descends in deluges—A dismal obscurity envelopes the earth with darkness—The superior regions appear rent with lightning and thunder—The earth often does and always seems to tremble—Terror and consternation distract all nature—Birds are carried from the woods into the ocean; and those whose element is the sea, seek for refuge on land—The frightened animals in the field assemble together, and are almost suffocated by the impetuosity of the wind in searching for shelter; which, when found, serves them only for destruction—The roofs of houses are carried to vast distances from their walls, which are beat to the ground, burying their inhabitants under them—Large trees are torn up by the roots, and huge branches shivered off, and driven through the air in every direction, with immense velocity—Every tree and shrub that withstands the shock, is stripped of its boughs and foliage—Plants and grass are laid flat on the earth—Luxuriant spring is changed in a moment to dreary winter.—This direful tragedy ended, when it happens in a town, the devastation is surveyed with accumulated horror; the harbour is covered with wrecks of boats and vessels; and the shore has not a vestige of its former state remaining. Mounds of rubbish and rafters in one place, heaps of earth and trunks of trees in another, deep gullies from torrents of water, and the dead and dying bodies of men, women, and children, half buried, and scattered about, where streets but a few hours before were, present the miserable survivors with a shocking conclusion of a spectacle to be followed by famine, and when accompanied by an earthquake by mortal diseases.

These destructive phenomena are now thought to arise from electricity, though the manner in which it acts in this case is by no means known. It seems probable, indeed, that not only hurricanes, but even the most gentle gales of wind, are produced by the action of the electric fluid; for which see WIND, WHIRLWIND, &c. METEOROLOGY Index.

HURST, HYRST, or HERST, are derived from the Saxon *hyrst*, i. e. a wood, or grove of trees. There are many places in Kent, Sussex, and Hampshire, which begin and end with this syllable; and the reason may be, because the great wood called *Andreswald* extended through those counties.

Hurst-Castle, a fortress of Hampshire in England, not far from Limington. It is seated on the extreme point of a neck of land which shoots into the sea, towards the isle of Wight, from which it is distant two miles.

HUSBAND, a man joined or contracted with a woman in marriage. See MARRIAGE.

HUSBAND-Land, a term used in Scotland for a portion of land containing six acres of sock and scythe land; that is, of land that may be tilled with a plough, and mown with a scythe.

HUSBANDRY, as defined by some, includes not only agriculture, but several other branches connected with it, such as the rearing of cattle, the management of the dairy, making butter and cheese, raising flax, timber, &c. See AGRICULTURE.

Virgilian HUSBANDRY, a term used by authors to express that sort of husbandry, the precepts of which are so beautifully delivered in Virgil's Georgics. The husbandry in England is Virgilian in general, as is seen by the method of paring and burning the surface, of rafting or cross-ploughing, and of the care in destroying weeds, upon the same principle, and by much the same means. In those parts of England along the southern coast, where the Romans principally inhabited, not only the practice, but the expressions, are in many respects the same with those of the ancient Romans, many of the terms used by the ploughmen being of Latin origin, and the same with those used by those people on the like occasions. And on a strict observation, more of Virgil's husbandry is at this time practised in England than in Italy itself. This change in the Italian husbandry is, however, much more to the credit of that people, than the retaining the Virgilian scheme is to ours.

Tull, who has established a new method of husbandry, observes, that it is upon the whole so contradictory to this old plan, that it may be called the *anti-Virgilian husbandry*; and adds that no practice can be worse than the Virgilian.

HUSK, the same with what botanists call the *calyx* or *cup* of a flower. See CALYX, BOTANY Index.

HUSO. See ACCIPENSER, ICHTHYOLOGY Index.

HUSS, JOHN. See HUSSITES.

HUSSARS, are the national cavalry of Hungary and Croatia. Their regimentals consist in a rough furred cap, adorned with a cock's feather (the officers either an eagle's or a heron's); a doublet, with a pair of breeches to which the stockings are fastened, and yellow or red boots: besides, they occasionally wear a short upper waistcoat edged with fur, and five rows of round metal buttons; and in bad weather a cloak. Their arms are a sabre, carbine, and pistols. They are irregular troops: hence, before beginning an attack, they lay themselves so flat on the necks of their horses, that it is hardly possible to discern their force; but being come within pistol-shot of the enemy, they raise themselves with such surprising quickness, and begin the fight with such vivacity on every side, that, unless the enemy is accustomed to their method of engaging, it is very difficult for troops to preserve their order. When a retreat is necessary, their horses have so much fire, and are so indefatigable, their equipage so light, and themselves such excellent horsemen, that no other cavalry can pretend to follow them. They leap over ditches, and swim over rivers, with surprising facility. They never encamp, and consequently are not burdened with any camp-equipage, saving a kettle and a hatchet to every six men. They always lie in the woods, out-houses, or villages, in the front of the army. The emperor, queen of Hungary, and king of Prussia, have the greatest number of troops under this name in their service.

HUSSITES, in ecclesiastical history, a party of reformers, the followers of John Huss.

John Huss, from whom the Hussites take their name.

Husband-Land.

Treatise on Tropical Diseases, &c.

Husbandry Hussites.

Hussites. name, was born in a little village in Bohemia, called *Huss*, and lived at Prague in the highest reputation, both on account of the sanctity of his manners and the purity of his doctrine. He was distinguished by his uncommon erudition and eloquence, and performed at the same time the functions of professor of divinity in the university, and of ordinary pastor in the church of that city. He adopted the sentiments of Wickliffe, and the Waldenses; and in the year 1407 began openly to oppose and preach against divers errors in doctrine, as well as corruptions in point of discipline, then reigning in the church. Huss likewise endeavoured to the utmost of his power to withdraw the university of Prague from the jurisdiction of Gregory XII. whom the kingdom of Bohemia had hitherto acknowledged as the true and lawful head of the church. This occasioned a violent quarrel between the incensed archbishop of Prague and the zealous reformer, which the latter inflamed and augmented from day to day, by his pathetic exclamations against the court of Rome, and the corruptions that prevailed among the sacerdotal order.

There were other circumstances that contributed to inflame the resentment of the clergy against him. He adopted the philosophical opinions of the realists, and vehemently opposed and even persecuted the nominalists, whose number and influence were considerable in the university of Prague. He also multiplied the number of his enemies in the year 1408, by procuring through his great credit, a sentence in favour of the Bohemians, who disputed with the Germans concerning the number of suffrages which their respective nations were intitled to in all matters that were carried by election in this university. In consequence of a decree obtained in favour of the former, which restored them to their constitutional right of three suffrages, usurped by the latter, the Germans withdrew from Prague, and, in the year 1409, founded a new academy at Leipsack. This event no sooner happened, than Huss began to inveigh with greater freedom than he had before done against the vices and corruptions of the clergy, and to recommend, in a public manner, the writings and opinions of Wickliffe, as far as they related to the papal hierarchy, the despotism of the court of Rome, and the corruption of the clergy. Hence an accusation was brought against him, in the year 1410, before the tribunal of John XXIII. by whom he was solemnly expelled from the communion of the church. Notwithstanding this sentence of excommunication, he proceeded to expose the Romish church with a fortitude and zeal that were almost universally applauded.

This eminent man, whose piety was equally sincere and fervent, though his zeal was perhaps too violent, and his prudence not always circumspect, was summoned to appear before the council of Constance. Secured, as he apprehended, from the rage of his enemies by the safe conduct granted him by the emperor Sigismund, for his journey to Constance, his residence in that place, and his return to his own country, John Huss obeyed the order of the council, and appeared before it to demonstrate his innocence, and to prove that the charge of his having deserted the church of Rome was entirely groundless. However, his enemies so far prevailed, that by the most scandalous breach of

public faith, he was cast into prison, declared a heretic because he refused to plead guilty against the dictates of his conscience, in obedience to the council, and burnt alive in 1415; a punishment which he endured with unparalleled magnanimity and resignation.

The same unhappy fate was borne by Jerome of Prague, his intimate companion, who attended the council, in order to support his persecuted friend. Jerome, indeed, was terrified into temporary submission; but he afterwards resumed his fortitude, and maintained the opinions, which he had for a while deserted through fear, in the flames in which he expired in 1416.

The disciples of Huss adhered to their master's doctrine after his death with a zeal which broke out into an open war, that was carried on with the most savage and unparalleled barbarity. John Ziska, a Bohemian knight, in 1420, put himself at the head of the Hussites, who were now become a very considerable party, and threw off the despotic yoke of Sigismund, who had treated their brethren in the most barbarous manner. Ziska was succeeded by Procopius, in the year 1424. The acts of barbarity that were committed on both sides were shocking and horrible beyond expression: for notwithstanding the irreconcilable opposition between the religious sentiments of the contending parties, they both agreed in this one horrible principle, that it was innocent and lawful to persecute and extirpate with fire and sword the enemies of the true religion; and such they reciprocally appeared to each other. Those commotions in a great measure subsided, by the interference of the council of Basil, in the year 1433.

The Hussites, who were divided into two parties, viz. the Calixtines and Taborites, spread over all Bohemia and Hungary, and even Silesia and Poland; and there are some remains of them still subsisting in all those parts.

HUSTINGS (from the Saxon word *hustinge*, i. e. *concilium*, or *curia*), a court held in Guildhall before the lord-mayor and aldermen of London, and reckoned the supreme court of the city. Here deeds may be enrolled, outlawries sued out, and replevins and writs of error determined. In this court also is the election of aldermen, of the four members of parliament for the city, &c. This court is very ancient, as appears by the laws of Edward the Confessor. Some other cities have likewise had a court bearing the same name, as Winchester, York, &c.

HUSUM, a town of Denmark, in the duchy of Sleswick, and capital of a bailiwick of the same name, with a strong ciadel and a very handsome church. It is seated near the river Ow, on the German sea; and is subject to the duke of Holstein-Gottorp. E. Long. 9. 4. N. Lat. 54. 5.

HUTCHESON, DR FRANCIS, a very elegant writer and excellent philosopher, was the son of a dissenting minister in the north of Ireland, and was born on the 8th of August 1694. He early discovered a superior capacity; and having gone through a school-education, began his course of philosophy at an academy, whence he removed to the university of Glasgow, where he applied himself to all the parts of literature, in which his progress was suitable to his uncommon abilities.

Hutcheson. He then returned to Ireland: and entering into the ministry, was just about to be settled in a small congregation of dissenters in the north of Ireland, when some gentlemen about Dublin, who knew his great abilities and virtues, invited him to take up a private academy there. He complied with the invitation, and met with much success. He had been fixed but a short time in Dublin, when his singular merits and accomplishments made him generally known; and his acquaintance was sought by men of all ranks, who had any taste for literature, or any regard for learned men. Lord Viscount Molesworth is said to have taken great pleasure in his conversation, and to have assisted him with his criticisms and observations upon his "Inquiry into the Ideas of Beauty and Virtue," before it came abroad. He received the same favour from Dr Syngé, lord bishop of Elphin, with whom he also lived in great friendship. The first edition of this performance came abroad without the author's name, but the merit of it would not suffer him to be long concealed. Such was the reputation of the work, and the ideas it had raised of the author, that Lord Granville, who was then lord lieutenant of Ireland, sent his private secretary to inquire at the bookseller's for the author; and when he could not learn his name, he left a letter to be conveyed to him: in consequence of which he soon became acquainted with his excellency, and was treated by him, all the time he continued in his government, with distinguished marks of familiarity and esteem.

From this time his acquaintance began to be still more courted by men of distinction either for station or literature in Ireland. Archbishop King, the author of the celebrated book *De origine mali*, held him in great esteem; and the friendship of that prelate was of great use to him in screening him from two different attempts made to prosecute him for daring to take upon him the education of youth, without having qualified himself by subscribing the ecclesiastical canons, and obtaining a license from the bishops. He had also a large share in the esteem of the primate Bolter, who through his influence made a donation to the university of Glasgow of a yearly fund for an exhibitioner to be bred to any of the learned professions. A few years after his Inquiry into the Ideas of Beauty and Virtue, his Treatise on the Passions was published: both these works have been often reprinted; and always admired, both for the sentiment and language, even by those who have not assented to the philosophy of them, nor allowed it to have any foundation in nature. About this time he wrote some philosophical papers accounting for laughter, in a different way from Hobbes, and more honourable to human nature: which papers were published in the collection called *Hibernicus's Letters*.

After he had taught in a private academy at Dublin for seven or eight years with great reputation and success, he was called in the year 1729, to Scotland, to be a professor of philosophy in the university of Glasgow. Several young gentlemen came along with him from the academy, and his high reputation drew many more thither both from England and Ireland. Here he spent the remainder of his life in a manner highly honourable to himself and ornamental to the university of which he was a member. His whole

time was divided between his studies and the duties of his office; except what he allotted to friendship and society. A firm constitution and a pretty uniform state of good health, except some few slight attacks of the gout, seemed to promise a longer life; yet he did not exceed the 53d year of his age. He was married, soon after his settlement in Dublin, to Mrs Mary Wilson, a gentleman's daughter in the county of Longford; by whom he left behind him one son, Francis Hutcheson, doctor of medicine. By this gentleman was published, from the original manuscript of his father, "A system of Moral Philosophy, in three books, by Francis Hutcheson, LL. D. at Glasgow, 1755," in two volumes, 4to.

HUTCHINSON, JOHN, a philosophical writer, whose notions have made no inconsiderable noise in the world, was born in 1674. He served the duke of Somerset in the capacity of steward; and in the course of his travels from place to place employed himself in collecting fossils: we are told that the large and noble collection bequeathed by Dr Woodward to the university of Cambridge was actually made by him, and even unfairly obtained from him. When he left the duke's service to indulge his studies with more freedom, the duke, then master of the horse to George I. made him his riding surveyor, a kind of sinecure place of 200l. a-year with a good house in the Meuse. In 1724 he published the first part of *Moses's Principia*, in which he ridiculed Dr Woodward's Natural History of the Earth, and exploded the doctrine of gravitation established in Newton's *Principia*: in 1727, he published a second part of *Moses's Principia*, containing the principles of the Scripture Philosophy. From this time to his death, he published a volume every year or two, which, with the MSS. he left behind, were published in 1748, in 12 vols 8vo. On the Monday before his death, Dr Mead urged him to be bled; saying pleasantly, "I will soon send you to Moses," meaning to his studies: but Mr Hutchinson taking it in the literal sense, answered in a muttering tone, "I believe, Doctor, you will;" and was so displeased, that he dismissed him for another physician; but died in a few days after, August 28. 1737. Singular as his notions are, they are not without some defenders, who have obtained the appellation of *Hutchinsonians*. The reader may find a distinct and comprehensive account of the Hutchinsonian system in a book intitled, *Thoughts concerning Religion, &c.* printed at Edinburgh 1743; and in a letter to a bishop, annexed to it, first printed in 1732.

HUTTON, DR JAMES, physician and naturalist, was the son of Mr William Hutton, a respectable merchant in Edinburgh. He was born on the 3d of June 1726, and lost his father while he was very young, the charge of his education devolving on his mother, who determined that it should be very liberal. Having finished his grammar-school education at the high school of Edinburgh, he entered the university at the age of 14 in the year 1740. He always considered himself as greatly indebted to Professor Stevenson's lectures on logic, not because they made him a logician, but because they accidentally gave him a predilection for chemistry which he retained and cherished to the close of life. As an illustration of some particular doctrine, the professor observed, that while the acids can only dissolve

Hutton. the baser metals, they must unite their strength before they can have any influence upon gold; that metal is only to be dissolved by nitro-muriatic acid, formerly denominated *aqua regia*. From this remark he found his thirst for chemical knowledge daily increase, and sought for information from every quarter.

He always evinced talents sufficient to encourage the prosecution of his studies; but it was the wish of his friends that he should turn his attention to business, with which he complied though contrary to his own inclinations. In 1743 he was put an apprentice to Mr George Chalmers, writer to the signet, where he soon discovered the ruling propensity of his mind; for when he should have been transcribing law papers, he was amusing his fellow apprentices with experiments in chemistry. Mr Chalmers perceiving this, generously freed him from his obligations to serve him, desiring him to turn his attention to some other employment more congenial to his views. He fixed his choice on the study of medicine as nearly related to his favourite pursuits, and after spending about three years at Edinburgh, he studied two years at Paris, and returning home by the Low Countries, took his degree of doctor of medicine at Leyden, in September 1749. The subject of his thesis was, *De Sanguine et Circulatione in Microcosmo*.

When he arrived in London, about the end of 1749, he conceived the design of settling in the world. He justly conjectured that Edinburgh did not hold out for him any flattering prospects in the capacity of a physician, as the principal practice was in the hands of a few eminent physicians who had been long established. He accordingly wrote to his friends in Edinburgh with much anxiety, as to the subject of his future prospects in life. To Mr James Davie, a young man nearly of his own age, with whom he contracted a friendship which death only could extinguish, he also communicated the perplexed state of his mind. Their mutual knowledge of the nature of sal ammoniac led them to establish this manufacture, which afterwards became a most lucrative concern to both. The sentiments of Mr Davie were communicated to Dr Hutton while yet in London, which probably was the chief reason why he resolved to abandon entirely the practice of physic.

On his return to Edinburgh, in the year 1750, he resolved to devote all his attention to agriculture, which might probably be occasioned by his having succeeded to a small property in Berwickshire on the death of his father. Mr Playfair of the university of Edinburgh has ascribed it, and we apprehend with great propriety, to the native simplicity of his character, and the moderation of his views, which were always free from ambition. His attachment to the life of a farmer was increased by his acquaintance with Sir John Hall of Dungaess, a gentleman who was very ingenious, a friend and lover of science, and one who well understood agriculture. Determined to make himself master of rural economy, Dr Hutton went into the county of Norfolk, where he continued for some time in the house of a farmer, who was at once his preceptor and his host. The farmer's name was John Dybold, whose practical knowledge of agriculture Dr Hutton always mentioned in terms of the highest respect.

During his residence in this county, which was to him a paradise, he made frequent excursions into different parts of England; and although information re-

specting rural economy was the great and primary object of his pursuit, yet it was here that he first commenced the study of mineralogy, to serve him as an amusement on the road. He acquainted his friend Sir John Hall, that he was become remarkably fond of studying the surface of the earth, and was narrowly examining every pit, or ditch, or bed of a river that fell in his way. The agricultural knowledge he acquired in Norfolk increased his desire to pay a visit to Flanders, the only place in Europe where husbandry can boast of the greatest antiquity. He set out accordingly in the spring of 1754, and returned to England during the summer of the same year. Soon after his arrival in London, he observed in a letter to Sir John Hall; "had I doubted of it before I set out, I should have returned fully convinced that they are good husbandmen in Norfolk."

About this time he returned to his native country, and was for some time at a loss what place to fix upon for the purpose of carrying into effect his agricultural improvements. His own farm at length became his choice, and a ploughman whom he had brought with him from Norfolk gave the first specimen of excellent tillage ever exhibited in that part of Scotland. To Dr Hutton the country is indebted for the introduction of the new husbandry into a county where it may be said to have made more astonishing progress than in almost any other part of the British empire. In the year 1764, he made an excursion into the north of Scotland, in company with Commissioner Clerk, who was afterwards Sir George Clerk, a man of singular worth and abilities. They went by Crief, Dalwhinnie, Fort Augustus, and Inverness, and returned along the coast by Aberdeen to Edinburgh. To increase his knowledge of geology was Dr Hutton's chief aim in this tour, to which he was now determined to pay the most unremitting attention. About the year 1768 he devoted his whole time to scientific pursuits, and having met with a favourable opportunity of letting his farm to advantage, he took up his constant residence in Edinburgh. He now turned his attention very much to the study of chemistry, and we believe he was the first who discovered that mineral alkali is contained in zeolite. The same fact has since been confirmed by the experiments of that celebrated mineralogist M. Klaproth, as well as by those of Dr Kennedy, which have led to others of a similar nature.

Dr Hutton gave the world his first publication in 1777, which was a small pamphlet of 37 pages, entitled, *Considerations on the nature, quality, and distinctions of Coal and Culm*. It was designed to answer a question which began to be much agitated, whether the small coal of Scotland is the same with the culm of England? and whether it ought to be carried coastwise free of all duty? This created a keen contest between the proprietors and revenue officers, the one insisting that it should, and the other that it should not pay any duty. It was discussed before the board of customs in Scotland, and even occupied the attention of the privy council. The small coal of Scotland was finally exempted from the payment of duty, to which the pamphlet of Dr Hutton greatly contributed.

During a period of 30 years the attention of the doctor was turned towards geological studies, to qualify

Hutton. him for writing on his favourite topic, a new theory of the earth. Long before that theory made its appearance in the world, he had completed the great outline of it, which was only shewn to a few confidential friends. He was first induced to publish it by communicating an abridgement of it to the Royal Society of Edinburgh. Of the merits or defects of this theory (for an account of which, see GEOLOGY), our readers must judge for themselves. It has found a very able advocate in Professor Playfair of the university of Edinburgh, whose illustrations of it have received a very candid and ingenious reply from an anonymous writer, who entitles his book, *A comparative view of the Huttonian and Neptunian systems of geology*. Dr Hutton's theory did not meet with that reception from the public which the doctor's admirers expected, and which it is probable he looked for himself. Professor Playfair thinks it was in a great measure owing to the obscurity with which he wrote, so repugnant to the perspicuity of his conversation; but as the world had received so many unsatisfactory theories before, it is not improbable that men were become disgusted with every thing of the kind, and almost determined to refuse a hearing to every subsequent attempt.

A theory of rain from the same author appeared in the first volume of the Edinburgh Transactions. He had made meteorology his study for a considerable time; and his theory has been pronounced one of the few to be met with in that department of knowledge which is deserving of the name. Soon after this publication, Dr Hutton gave the world, in three volumes quarto, *An investigation of the principles of knowledge, and of the progress of reason from sense to science and philosophy*. His elements of agriculture, the result of much study and long experience, was the last work which he seemed anxious to publish, but it was left in manuscript at his death, which took place in 1796-7. On the 26th of March he was seized with a shivering, which induced him to send for his friend Mr Russel, who attended him as surgeon; but before it was possible for that gentleman to arrive, all medical aid was absolutely vain. Having with some difficulty stretched out his hand to Mr Russel, he instantly expired.

To the name of a philosopher Dr Hutton was most justly entitled, by virtue of his natural talents, acquisitions, and temper. The direction of his studies was rather uncommon and irregular; but for that very reason it was peculiarly fitted to develop his quick penetration and originality of thought, by which his intellectual character was strikingly marked. The vast acquisitions of wealth and fortune never excited more lively sensations of pleasure in the minds of men, than those which arose in the mind of Dr Hutton on hearing of a new invention, or the being made acquainted with a new truth. This pleasure, which appeared almost ridiculous to those who could not enter into his views, was not confined to any one branch of science; for in the language of Professor Playfair, "he would rejoice over Watt's improvements on the steam engine, or Cook's discoveries in the South sea, with all the warmth of a man who was to share in the honour or the profit about to accrue from them." Dr Hutton was not exclusively attached to the company of men of letters, whose conversation was entirely directed to subjects of literature; for he could occasionally unbend himself, and enjoy the innocent hilarity of promiscuous company, when he

freely indulged in the gratification of his native pleasure.

Dr Hutton was never married, but kept house with his three sisters, who were ornaments to their sex, and had the sole management of his domestic concerns. One of them, Miss Isabella, survived her worthy brother, and lived to lament a death which was certainly a loss to the literary world, as a very large share of his knowledge unavoidably perished with himself. He left no particular directions behind him as to the disposal of his collection of fossils, which was accordingly presented to Dr Black, who gave it to the Royal Society of Edinburgh, on condition that it should be completely arranged, and always kept separate, for the purpose of illustrating the Huttonian Theory of the Earth.

HUXING of pike, among fishermen, a particular method of catching that fish.

For this purpose, they take 30 or 40 as large bladders as can be got; blow them up, and tie them close and strong; and at the mouth of each tie a line, longer or shorter according to the depth of the water. At the end of the line is fastened an armed hook, artfully baited: and thus they are put into the water with the advantage of the wind, that they may gently move up and down the pond. When a master pike has struck himself, it affords great entertainment to see him bounce about in the water with a bladder fastened to him; at last, when they perceive him almost spent, they take him up.

HUY, a town of the Netherlands, in the bishopric of Liege, and capital of Condrass. It is advantageously seated on the river Maese, over which there is a bridge. E. Long. 5. 15. N. Lat. 50. 32.

HUYGENS, CHRISTIAN, one of the greatest mathematicians and astronomers of the 17th century, was the son of Constantine Huygens, lord of Zuylichem, who had served three successive princes of Orange in the quality of secretary; and was born at the Hague, in 1629. He discovered from his infancy an extraordinary fondness for the mathematics; in a little time made a great progress in them; and perfected himself in those studies under the famous professor Schooten, at Leyden. In 1649, he went to Holstein and Denmark, in the retinue of Henry count of Nassau; and was extremely desirous of going to Sweden, in order to see Des Cartes, but the count's short stay in Denmark, would not permit him. He travelled into France and England; was, in 1663, made a member of the Royal Society; and, upon his return into France, M. Colbert, being informed of his merit, settled a considerable pension upon him to engage him to fix at Paris; to which Mr Huygens consented, and staid there from the year 1666 to 1681, where he was admitted a member of the Academy of Sciences. He lived a quiet and studious manner of life, and frequently retired into the country to avoid interruption, but did not contract that moroseness which is so frequently the effect of solitude and retirement. He was the first who discovered Saturn's ring, and a third satellite belonging to that planet, which had hitherto escaped the eyes of astronomers. He discovered the means of rendering clocks exact, by applying the pendulum, and rendering all its vibrations equal by the cycloid. He brought telescopes to perfection, made many other useful discoveries, and died at the Hague in 1695. He

Hutton
|
Huygens.

Huygens,
Huysum.

was the author of several excellent works. The principal of these are contained in two collections; the first of which was printed at Leyden in 1682, in quarto, under the title of *Opera varia*; and the second at Amsterdam in 1728, in two volumes quarto, entitled *Opera reliqua*.

HUYSUM, the name of several Dutch painters; the most celebrated of whom was John, whose subjects were flowers, fruit, and landscapes. According to Mr Pilkington, this illustrious painter hath surpassed all who have ever painted in that style; and his works excite as much surprise by their finishing as they excite admiration by their truth. He was born at Amsterdam in 1682, and was a disciple of Justus van Huysum his father. He set out in his profession with a most commendable principle, not so much to paint for the acquisition of money as of fame; and therefore he did not aim at expedition, but at delicacy, and, if possible, to arrive at perfection in his art. Having attentively studied the pictures of Mignon, and all other artists of distinction who had painted in his own style, he tried which manner would soonest lead him to imitate the lightness and singular beauties of each flower, fruit, or plant, and then fixed on a manner peculiar to himself, which seems almost inimitable. His pictures are finished with inconceivable truth; for he painted every thing after nature; and was so singularly exact, as to watch even the hour of the day in which his model appeared in its greatest perfection. By the judicious he was accounted to paint with greater freedom than Mignon or Broughel; with more tenderness and nature than Mario da Fiori, Michael Angelo di Campidoglio, or Segers; with more mellowness than De Heem, and greater force of colouring than Baptist. His reputation rose to such a height at last, that he fixed immoderate prices on his works; so that none but princes, or those of princely fortunes, could pretend to become purchasers. Six of his paintings were sold at a public sale in Holland for prices that were almost incredible. One of them, a flower-piece, for fourteen hundred and fifty guilders; a fruit-piece for a thousand and five guilders; and the smaller pictures for nine hundred. The vast sums which Van Huysum received for his works, caused him to redouble his endeavours to excel; no person was admitted into his room while he was painting, not even his brothers; and his method of mixing the tints, and preserving the lustre of his colours, was an impenetrable secret, which he never would disclose. Yet this conduct is certainly not to his honour, but rather an argument of a low mind, fearful of being equalled or surpassed. From the same principle, he would never take any disciples, except one lady, named Haverman; and he grew envious and jealous even of her merit. By several domestic disquiets his temper became changed; he grew morose, fretful, and apt to withdraw himself from society. He had many enviers of his fame, which has ever been the severe lot of the most deserving in all professions; but he continued to work, and his reputation never diminished. It is universally agreed that he has excelled all who have painted fruit and flowers before him, by the confessed superiority of his touch, by the delicacy of his pencil, and by an amazing manner of finishing; nor does it appear probable that any future artist will

become his competitor. The care which he took to purify his oils and prepare his colours, and the various experiments he made to discover the most lustrous and durable, are instances of extraordinary care and industry as well as capacity. From having observed some of his works that were perfectly finished, some only half finished, and others only begun, the principles by which he conducted himself may perhaps be discoverable. His cloths were prepared with the greatest care, and primed with white, with all possible purity, to prevent his colours from being obscured, as he laid them on very lightly. He glazed all other colours except the clear and transparent, not omitting even the white ones, till he found the exact tone of the colour; and over that he finished the forms, the lights, the shadows and the reflections, which are all executed with precision and warmth, without dryness or negligence. The greatest truth, united with the greatest brilliancy, and a velvet softness on the surface of his objects, are visible in every part of his compositions; and as to his touch, it looks like the pencil of nature. Whenever he represented flowers placed in vases, he always painted those vases after some elegant model, and the bas-relief is as exquisitely finished as any of the other parts. Through the whole he shows a delicate composition, a fine harmony, and a most happy effect of light and shadow. Those pictures which he painted on a clear ground are preferred to others of his hand, as having greatest lustre, and as they demanded more care and exactness in the finishing; yet there are some on a darkish ground, in which appears rather more force and harmony. It is observed of him, that in the grouping of his flowers, he generally designed those which were brightest in the centre, and gradually decreased the force of his colour from the centre to the extremities. The birds nests and their eggs, the feathers, insects, and drops of dew, are expressed with the utmost truth, so as even to deceive the spectator. And yet, after all this merited and just praise, it cannot but be confessed, that sometimes his fruits appear like wax or ivory, without that peculiar softness and warmth which is constantly observable in nature. Beside his merit as a flower painter, he also painted landscapes with great applause. They are well composed; and although he had never seen Rome, he adorned his scenes with the noble remains of ancient magnificence which are in that city. His pictures in that style are well coloured, and every tree is distinguished by a touch that is proper for the leafing. The grounds are well broken, and disposed with taste and judgment; the figures are designed in the manner of Lairease, highly finished, and touched with a great deal of spirit; and through the whole composition the scene represents Italy, in the trees, the clouds, and the skies. He died in 1749, aged 67.

HUZZOOR, a Hindoostan word, signifying *The presence*; applied, by way of eminence, to the Mogul's court. According to polite usage, it is now applied to the presence of every nabob or great man.

Huzzoor News; the secretary who resides at court, and keeps copies of all the *firmans*, records, or letters.

HYACINTH, in *Natural History*, a species of the zircon genus. See ZIRCON, MINERALOGY *Index*.

HYACINTHUS, HYACINTH, a genus of plants, belonging

Huy
Hyaci
thus

Hyacinthus belonging to the hexandria class; and in the natural method ranking under the 10th order, *Coronaria*. See *Hybla*. BOTANY *Index*.

HYACINTHIA, in antiquity, feasts held at Sparta, in honour of Apollo, and in commemoration of his favourite Hyacinth.

This Hyacinth was the son of Amyclas king of Sparta, and was beloved both by Apollo and Zephyrus. The youth showing most inclination to the former, his rival grew jealous; and, to be revenged, one day as Apollo was playing at the discus, i. e. quoits, with Hyacinth, Zephyrus turned the direction of a quoit which Apollo had pitched full upon the head of the unhappy Hyacinth, who fell down dead. Apollo then transformed him into a flower of the same name; and as a farther token of respect, they say, commanded this feast. The Hyacinthia lasted three days; the first and third whereof were employed in bewailing the death of Hyacinth, and the second in feasting and rejoicing.

HYADES, in *Astronomy*, are seven stars in the bull's head, famous among the poets for the bringing of rain. Whence their name *Ἰάδες*, from the Greek *ἵω*, "to rain." The principal of them is in the left eye, by the Arabs called *Aldebaran*.

The poets feign them the daughters of Atlas and Pleone. Their brother Hyas being torn to pieces by a lioness, they wept his death with such vehemence, that the gods, in compassion to them, translated them into heaven, and placed them in the bull's forehead, where they continue to weep; this constellation being supposed to presage rain. Others represent the Hyades as Bacchus's nurses; and the same with the Dodonides, who fearing the resentment of Juno, and flying from the cruelty of King Lycurgus, were translated by Jupiter into heaven.

HYÆNA. See *CANIS*, *MAMMALIA Index*.

HYÆNIUS LAPIS, in *Natural History*, the name of a stone said to be found in the eyes of the hyæna. Pliny tells us, that those creatures were in old times hunted and destroyed for the sake of those stones, and that it was supposed they gave a man the gift of prophecy by being put under his tongue.

HYBERNACULUM, in *Botany*, **WINTER-QUARTERS**; defined by Linnæus to be that part of the plant which defends the embryo herb from injuries during the severities of the winter. See *BULB* and *GEMMA*.

HYBLA, in *Ancient Geography*, or **MEGARA**; which last name it took from the Megareans, who led thither a colony; called also *Hybla Parva* and *Galeotis*. In Strabo's time Megara was extinct; but the name *Hybla* remained on account of its excellent honey named from it. It was situated on the east coast of Sicily, between Syracuse and the Leontines. *Galeotæ* and *Megarenses*, the names of the people, who were of a prophetic spirit, being the descendants of Galeus the son of Apollo. *Hyblaicus* the epithet.—The *Hyblæi colles*, small eminences at the springs of the Alabus near this place, were famous from their variety of flowers, especially thyme; the honey gathered from which was by the ancients reckoned the best in the world, excepting that of Hymettus in Attica. By the moderns it was called *Mel Passi*, for the same reason, namely, on account of its excellent honey, and extraordinary fertility, till it was overwhelmed by the lava of *Ætna*; and hav-

ing then become totally barren, its name was changed to *Mal Passi*. In a second eruption, by a shower of ashes from the mountain, it soon reassumed its ancient beauty and fertility, and for many years was called *Bel Passi*: and, last of all, in the year 1669, it was again laid under an ocean of fire, and reduced to the most wretched sterility; since which time it is again known by the appellation of *Mal Passi*. However, the lava, in its course over this beautiful country, has left several little islands or hillocks, just sufficient to show what it formerly was. These make a singular appearance in all the bloom of the most luxuriant vegetation, surrounded and rendered almost inaccessible by large fields of black and rugged lava.

HYBLA Major, in *Ancient Geography*, was situated in the tract lying between Mount *Ætna* and the river *Symethus*. In Pausanius's time desolate.

HYBLA Major, or *Heræa*, in *Ancient Geography*, an inland town of Sicily, situated between the rivers *Oanus* and *Herminius*. Now *RAGUSA*.

HYBRIDA PLANTA, a monstrous production of two different species of plants, analogous to a mule among animals. The seeds of hybrid plants will not propagate.

HYBRISTICA, (of *ἵβρις*, *injurium*), in antiquity, a solemn feast held among the Greeks, with sacrifices and other ceremonies, at which the men attended in the apparel of women, and the women in that of men, to do honour to Venus in quality either of a god or a goddess, or both. Or, according to the account given by others, the *hybristica* was a feast celebrated at Argos, wherein the women being dressed like men, insulted their husbands, and treated them with all marks of superiority, in memory of the Argian dames having anciently defended their country with singular courage against Cleomenes and Demaratus.

Plutarch speaks of this feast in his treatise of the great actions of women. The name, he observes, signifies infamy; which is well accommodated to the occasion, wherein the women strutted about in men's clothes, while the men were obliged to dangle in petticoats.

HYDATIDES, in *Medicine*, little transparent vesicles or bladders full of water, sometimes found solitary, and sometimes in clusters, upon the liver and various other parts, especially in hydropical cases.

HYDATOSCOPIA, called also **HYDROMANCY**, a kind of divination or method of foretelling future events by water.

HYDE, EDWARD, earl of Clarendon, and lord high-chancellor of England, was a very eminent statesman and historian, son of Henry Hyde, a private gentleman, resident at Dinton in Wiltshire, where his lordship was born, in the month of February 1608. The first rudiments of his education he received in his father's house, the vicar of the parish being his preceptor, under whose tuition he made such rapid progress, that he was sent to Oxford at the age of 13, where he studied only for one year in Magdalen-hall, as his father entered him in the Middle Temple, that he might be trained up to the profession of the law. He repaired to London at the age of 17, being countenanced and protected by his uncle, who was afterwards chief justice of the court of king's bench. On the death of his uncle he was still a student, yet such a heavy

Hybla
||
Hyde.

Hyde.

heavy misfortune did not deter him from the prosecution of his designs. As a licentiousness of manners was at that time extremely prevalent, the well-disposed part of the community considered early marriage as a commendable preservative against irregularity of conduct; and therefore in compliance with an opinion so respectable, Mr Hyde united himself in wedlock with a beautiful young lady, when he was only in the 21st year of his age, whom he had the misfortune to lose in six months after the celebration of their nuptials, she having fallen a victim to that loathsome malady the smallpox. After a widowhood of three years continuance, he married the daughter of Sir Thomas Aylesbury, with whom he lived 36 years in conjugal felicity. He considered it as a fortunate circumstance that he was made acquainted at an early period with a number of very distinguished characters, among whom we find the names of Lord Falkland, Selden, Kenelm Digby, Carew, Sheldon, May, Waller, Hales of Eton, Morley, Chillingworth, and others; of whom he has made respectable mention in memoirs written by himself; and to their instructive conversation he nobly ascribes the principal part of his literary acquisitions. His diffidence is very amiably expressed in these words; "that he never was so proud, or thought himself so good a man, as when he was the worst man in the company."

Being concerned in a cause in behalf of the merchants of London, he was thus introduced to the notice of Archbishop Laud, commissioner of the treasury, by whom he was treated with much respect, and had his advancement in the profession of the law greatly promoted. His easy circumstances and respectable connections powerfully contributed to bring him forward and increase his business as a barrister. But in the multiplicity of causes which he was employed to bring before different courts, he never lost sight of polite literature, on the study of which he bestowed indefatigable attention, and in his general deportment he exhibited more of the polished gentleman than of the mere lawyer. So great was the reputation which by this time he had acquired, that in 1640 he was chosen burgess for Wotton-Basset and Shaftesbury, in the parliament summoned by Charles I. on account of the Scotch rebellion. As public grievances first attracted the attention of this new parliament, Hyde brought forward a statement of the illegal oppressions and malpractices of the earl marshal's court; but as it was soon dissolved, a radical investigation of the conduct of that court was for a time prevented. The borough of Saltash made choice of him for the new parliament, in which he pleaded so effectually against the earl marshal's court as to procure its suppression. He now totally abandoned the profession of a barrister, and wholly confined himself to the discussion of public business; and as he was generally supposed to be attached to no particular party, he was frequently appointed chairman of committees in the transaction of the most important affairs.

Hyde was represented to his majesty in such a favourable light, that the king requested a private interview with him, in the course of which he expressed his great obligations to him for his meritorious services, and was much pleased with his zealous attachment to the church. After this interview he may be considered as devoted to the royal cause; and in order to make a

Hyde.

proper estimate of his subsequent conduct, it will be necessary for our readers to attend to his own declaration. He informs us that he had "a very particular passion and devotion for the person of the king; and a most zealous esteem and reverence for the constitution of government, which he believed to be so equally poised, that if the least branch of the prerogative was torn off, the subject suffered by it; and he was as much troubled when the crown exceeded its just limits." He believed the church of England to be most admirably calculated for the promotion of literature, piety, and peace, perhaps of any other in the whole world, and deemed the application of any part of its revenue to civil purposes to be the most abominable sacrilege and unpardonable robbery. He also considered the removal of bishops from the house of peers as a violation of the principles of justice, which made him an enemy to every innovation in the church from conscientious motives.

When the commons published their remonstrance on the state of the nation, Hyde drew up a reply to it, merely to gratify his own personal indignation, according to his own confession, without the smallest intention of making it public, although it is more than probable that Lord Digby was made acquainted with its contents. He was, however, at length prevailed upon to allow it to appear as the king's answer with the advice of his council. This procured him an offer of the office of solicitor-general, which he thought proper to decline, although he undertook the management of the king's affairs in parliament, in conjunction with Lord Digby and Sir John Colepepper. He opposed the king's assent to the bill for depriving the bishops of their seats in the house of peers, in which the sovereign acted in direct opposition to the sentiments of his professed friend, by giving his assent. In the year 1642 his majesty sent for Hyde to York, where he contributed his assistance in drawing up various papers in the cause of the falling monarch. He was recalled by parliament, but he refused to obey the summons without the royal permission, which excluded him from pardon by a vote of the house.

Soon after the breaking out of hostilities between the king and parliament, when the court of the former was held at Oxford, Hyde was appointed chancellor of the exchequer, sworn a member of the privy council, and created a knight. He continued with his majesty till the month of March 1644, when he was appointed to accompany Prince Charles to the west, and afterwards to the island of Jersey, where Sir Edward Hyde continued during two years after the departure of the prince, prosecuting his studies with indefatigable industry, and composing a history of those memorable transactions in which he himself had borne a distinguished part. He likewise published a reply to the parliamentary declaration of February 1647, in which it was declared improper to send any more addresses to the king. In 1648 he received orders to attend the prince at Paris, who having in the mean time set out for Holland, Sir Edward took shipping for Dunkirk. The prince was at the Hague when he received the melancholy intelligence of his royal father's fate. Upon this the council of the young king determined to send ambassadors to Spain, and for this purpose made choice of Sir Edward Hyde and Lord Collington, who arrived at Madrid in 1694; and when their residence in that metropolis

Hyde. *ropolis was no longer necessary, Sir Edward returned to Paris. The king's court at the Hague was torn by dissension, which made Sir Edward apply for, and obtain leave to retire to Antwerp, the residence of his wife and children, as he clearly perceived that his personal attendance was not likely to be productive of any substantial good. This retreat afforded him literary and domestic happiness, and was better suited to the reduced state of his finances. The princess of Orange, eldest daughter of the unfortunate Charles I. having assigned Sir Edward a house at Breda free of rent, out of gratitude for his warm attachment to her father, he was prevailed upon to remove to that city.*

In the year 1657 he was appointed lord high-chancellor of England; a nomination which to our readers may probably seem ridiculous, as coming from a king who was not possessed of a kingdom; but it should be remembered that the young sovereign was of an easy and too pliable a disposition, incapable of denying any request; and therefore as applications were continually made to him for contingent grants and reversions, he justly considered it as a prudent step to raise a man to that high rank, who had sufficient firmness to reject all improper requisitions.

It is but doing justice to the memory of Sir Edward Hyde to say that he was the most confidential and faithful minister of Charles II. at the time of the restoration; and by the consent of all parties, the many public and private difficulties which this event occasioned, were settled by him with much wisdom, integrity and honour. Notwithstanding he was a warm advocate for the royal prerogative, it says much for the wisdom of his head and the goodness of his heart, that he was an enemy to the extension of it beyond the limits prescribed by the constitution; for when it was proposed to raise a great standing revenue, which would have made the king independent of parliament, it met from Sir Edward the warmest opposition, and he restrained the zeal of the royalists, and their desire of revenge. His zeal for episcopacy was, however, carried to an extravagant height, as it led him to wish for the annihilation of every vestige of presbyterianism. He was chosen chancellor of the university of Oxford in 1690, and at the same time created a peer; being in the year following made Viscount Corbary and earl of Clarendon. But as his new dignity was far superior to his fortune, the crown made several grants to him to enable him to support it. This sudden elevation, and the strictness of his moral deportment, which bordered on austerity, did not fail to create a number of enemies in such a licentious court as that of Charles II.

It would perhaps be improper to omit a remarkable circumstance respecting his daughter, who was a maid of honour to the princess of Orange, as it had every appearance of affecting his future fortune in a very material degree. The duke of York was so captivated with the charms of his lordship's daughter, that he entered with her into a private contract of marriage, when he found it impracticable to triumph over her virtue, or procure her for a mistress. Finding herself pregnant, she boldly insisted that the duke would make an open avowal of their marriage, which rendered it necessary to make the king acquainted with it; but when it reached the ears of her father, he behaved on the occasion in such a manner, as greatly to tarnish a

character so illustrious. He said he would rather see his daughter the duke's mistress than his consort; advised to confine her in the Tower, and even asserted that she ought to lose her head. He was afraid of the king's indignation, from a supposition that he was privy to the marriage, which there is no good reason for believing, yet such an apprehension might bring such expressions from him as were wholly incompatible with the feelings of a parent. His extravagant notions of royalty might also have their own weight in producing such an unnatural conduct, since he would conceive the blood of majesty to be contaminated by such an alliance. To the honour of Charles he behaved on the occasion in a very commendable manner; and notwithstanding the rage of the queen-mother, the base conduct of the duke in denying his marriage, and attempting by calumny to impeach the chastity of his consort, she was at length acknowledged as the duchess of York, and became the mother of two English queens.

Earl Clarendon's influence with the crown was naturally increased by this marriage, while it as naturally procured him the envy of his fellow courtiers, and paved the way to his subsequent degradation. The sale of Dupkirck to the French was viewed as dishonourable by the nation at large, although perhaps on the score of economy and sound policy it was capable of vindication. To this we may add the unpopular measure of opposing the bill for granting liberty of conscience, as it brought on him the displeasure both of the king and of all religious sectaries. Even the unfortunate war with the Dutch was charged to his account, although he was known to be its enemy from its very commencement. Rigidly virtuous himself, the libidinous course of life pursued by his master could not fail to give him offence, and he certainly displeased the king by the freedom of his reproofs. In defiance, therefore, of all his former services, he was basely abandoned to the indignation of the people, and driven from every office of public trust in the month of August 1667. He was charged with the crime of high-treason by the house of commons, but the peers refused to commit him upon their charge; but while the dispute between the two houses was yet undetermined, Clarendon received his majesty's orders to quit the kingdom. His apology to the peers was burnt by the common executioner, and a bill of banishment was issued against him for flying from justice. While he proceeded from Calais to Rouen, the court of France sent an order to him to quit that kingdom, which bodily distress at that time rendered impracticable, upon which the cruel order was reversed. The savage rage of some Englishmen nearly deprived him of his life as he passed from Rouen to Avignon after his recovery; but the court of France punished the perpetrators of the deed. At Montpellier he met with very respectful treatment during a residence of four years, which time he devoted to the vindication of his conduct. Having spent some time at Moulins, he fixed his residence at Rouen, where he terminated his career in December 1674, in the 68th year of his age. His remains were brought to England, and interred in the abbey of Westminster.

Lord Clarendon was the author of Contemplations and Reflections on the Psalms; Animadversions on a book of Mr Cressy's in the Roman Catholic Controver-

Hyde.

Hyde
||
Hydra.

sy; A brief view of the Errors in Hobbes's Leviathan; History of the grand Rebellion; his own Life and a Continuation of his History, published by the university in 1759. In a literary point of view his lordship is only known as a historian; and his history of the civil war is regarded by competent judges as an important source of information. The writings of Clarendon resemble those of a man who takes a decided part, yet his representations are generally allowed to be moderate and just. His language is not devoid of beauty; but his injudicious use of the relative pronoun often renders him obscure; few however have ever excelled him in the delineation of characters.

HYDE, *Dr Thomas*, professor of Arabic at Oxford, and one of the most learned writers of the 17th century, was born in 1636; and studied first at Cambridge, and afterwards at Oxford. Before he was 18 years of age, he was sent from Cambridge to London to assist Mr Brian Walton in the great work of the Polyglot Bible; and about that period undertook to transcribe the Persian Pentateuch out of the Hebrew characters, which Archbishop Usher, who well knew the difficulty of the undertaking, pronounced to be an impossible task to a native Persian. After he had happily succeeded in this, he assisted in correcting several parts of Mr Walton's work, for which he was perfectly qualified. He was made archdeacon of Gloucester, canon of Christ-church, head-keeper of the Bodleian library, and professor both of Hebrew and Arabic in the university of Oxford. He was interpreter and secretary of the Oriental languages, during the reigns of Charles II. James II. and William III.; and was perfectly qualified to fill this post, as he could converse in the languages which he understood. There never was an Englishman in his situation of life who made so great a progress; but his mind was so engrossed by his beloved studies, that he is said to have been but ill qualified to appear to any advantage in common conversation. Of all his learned works (the very catalogue of which, as observed by Anth. Wood, is a curiosity), his *Religio Veterum Persarum* is the most celebrated. Dr Gregory Sharpe, the late learned and ingenious master of the Temple, has collected several of his pieces formerly printed, and republished them with some additional dissertations, and his life prefixed, in two elegant volumes quarto. This great man died on the 18th of February 1702. Among his other works are, 1. A Latin translation of Ulug Beig's observations on the longitude and latitude of the fixed stars; and, 2. A catalogue of the printed books in the Bodleian library.

HYDNUM, a genus of the natural order of fungi, belonging to the cryptogamia class of plants. See BOTANY *Index*.

HYDRA, in fabulous history, a serpent in the marsh of Lerna, in Peloponnesus, represented by the poets with many heads, one of which being cut off, another immediately succeeded in its place, unless the wound was instantly cauterized. Hercules attacked this monster; and having caused Iolaus to hew down wood for flaming brands, as he cut off the heads he ap-

plied the brands to the wounds, by which means he destroyed the hydra.

This hydra with many heads is said to have been only a multitude of serpents, which infested the marshes of Lerna near Mycene, and which seemed to multiply as they were destroyed. Hercules, with the assistance of his companions, cleared the country of them, by burning the reeds in which they lodged.

HYDRA, in *Astronomy*, a southern constellation, consisting of a number of stars, imagined to represent a water serpent. The stars in Hydra, in Ptolemy's catalogue, are twenty-seven; in Tycho's, nineteen; in Hevelius's, thirty-one.

HYDRA, in *Zoology*, a genus of the order of zoophyta, belonging to the class of vermes. See HELMINTHOLOGY *Index*.

HYDRAGOGUES, among physicians, remedies which evacuate a large quantity of water in dropsies. The word is formed of *ιδμε*, water, and *αγω*, to draw or lead; but the application of the term proceeds upon a mistaken supposition, that every purgative had some particular humour which it would evacuate, and which could not be evacuated by any other. It is now, however, discovered, that all strong purgatives will prove *hydragogues*, if given in large quantity, or in weak constitutions. The principal medicines recommended as *hydragogues*, are the juice of elder, the root of iris, soldanella, mechoacan, jalap, &c.

HYDRANGEA, a genus of plants belonging to the decandria class, and in the natural method ranking under the 13th order, *Succulentæ*. See BOTANY *Index*.

HYDRASTIS, a genus of plants, belonging to the polyandria class, and in the natural method ranking with those of which the order is doubtful. See BOTANY *Index*.

HYDRARGYRUM, a name given to mercury, or quicksilver. The word is formed of *ιδμε*, aqua, "water," and *αργυρος*, argentum, "silver;" q. d. *water of silver*, on account of its resembling liquid or melted silver.

HYDRAULICS, the science of the motion of fluids and the construction of all kinds of machines relating thereto. See HYDRODYNAMICS in this work, and HYDRAULICS, SUPPLEMENT.

HYDRENTEROCELE, in *Surgery*, a species of hernia, wherein the intestines descend into the scrotum, together with a quantity of water.

HYDROCEPHALUS, a preternatural distension of the head to an uncommon size by a stagnation and extravasation of the lymph; which, when collected in the inside of the cranium, is then termed *internal*; as that collected on the outside is termed *external*. See MEDICINE *Index*.

HYDROCHARIS, the LITTLE WATER-LILY, a genus of plants belonging to the diœcia class, and in the natural method ranking under the first order, *Palmae*. See BOTANY *Index*.

HYDROCOTYLE, WATER-NAVELWORT, a genus of plants belonging to the pentandria class, and in the natural method ranking under the 45th order, *Umbellatæ*. See BOTANY *Index*.

Hydra
||
Hydrocotyle.

HYDRODYNAMICS.

History. 1. **HYDRODYNAMICS**, from ὕδωρ, "water," and Δύναμις, "power," is properly that science which **Definition.** treats of the power of water, whether it acts by pressure or by impulse. In its more enlarged acceptation, however, it treats of the pressure, equilibrium, cohesion, and motion of fluids, and of the machines by which water is raised, or in which that fluid is employed as the first mover. Hydrodynamics is divided into two branches, *Hydrostatics* and *Hydraulics*. Hydrostatics comprehends the pressure, equilibrium, and cohesion of fluids, and Hydraulics their motion, together with the machines in which they are chiefly concerned.

HISTORY.

Hydrodynamics, in some respects, a modern science.

2. The science of hydrodynamics was cultivated with less success among the ancients than any other branch of mechanical philosophy. When the human mind had made considerable progress in the other departments of physical science, the doctrine of fluids had not begun to occupy the attention of philosophers; and, if we except a few propositions on the pressure and equilibrium of water, hydrodynamics must be regarded as a modern science, which owes its existence and improvement to those great men who adorned the 17th and 18th centuries.

Discoveries of Archimedes.

3. Those general principles of hydrostatics which are to this day employed as the foundation of that part of the science, were first given by Archimedes in his work *De Insidentibus Humido*, about 250 years before the birth of Christ, and were afterwards applied to experiments by Marinus Ghetaldus in his *Archimedes Promotus*. Archimedes maintained that each particle of a fluid mass, when in equilibrio, is equally pressed in every direction; and he inquired into the conditions, according to which a solid body floating in a fluid should assume and preserve a position of equilibrium. We are also indebted to the philosopher of Syracuse for that ingenious hydrostatic process by which the purity of the precious metals can be ascertained, and for the screw engine which goes by his name, the theory of which has lately exercised the ingenuity of some of our greatest mathematicians.

Inventions of Ctesibius and Hero.

4. In the Greek school at Alexandria which flourished under the auspices of the Ptolemies, the first attempts were made at the construction of hydraulic machinery. About 120 years after the birth of Christ, the fountain of compression, the syphon, and the forcing pump, were invented by Ctesibius and Hero; and though these machines operated by the elasticity and weight of the air, yet their inventors had no distinct notions of these preliminary branches of pneumatical science. The syphon is a simple instrument which is employed to empty vessels full of water or spirituous liquors, and is of great utility in the arts. The forcing pump, on the contrary, is a complicated and abstruse invention, which could scarcely have been expected in the infancy of hydraulics. It was probably suggested to Ctesibius by the *Egyptian wheel* or *Noria*, which

Vol. X. Part II. †

Forcing pump.

Egyptian wheel.

History. was common at that time, and which was a kind of chain pump, consisting of a number of earthen pots carried round by a wheel. In some of these machines the pots have a valve in their bottom which enables them to descend without much resistance, and diminishes greatly the load upon the wheel; and if we suppose that this valve was introduced so early as the time of Ctesibius, it is not difficult to perceive how such a machine might have led this philosopher to the invention of the forcing pump.

5. Notwithstanding these inventions of the Alexandrian school, its attention does not seem to have been directed to the motion of fluids. The first attempt to investigate this subject was made by Sextus Julius Frontinus, inspector of the public fountains at Rome in the reigns of Nerva and Trajan; and we may justly suppose that his work entitled *De Aquæductibus urbis Romæ Commentarius* contains all the hydraulic knowledge of the ancients. After describing the Roman aqueducts, and mentioning the dates of their erection, he considers the methods which were at that time employed for ascertaining the quantity of water discharged from adjutages, and the mode of distributing the waters of an aqueduct or a fountain. He justly remarks that the expence of water from an orifice, depended not only on the magnitude of the orifice itself, but also on the height of the water in the reservoir; and that a pipe employed to carry off a portion of water from an aqueduct, should, as circumstances required, have a position more or less inclined to the original direction of the current. But as he was unacquainted with the true law of the velocities of running water as depending upon the depth of the orifice, we can scarcely be surprised at the want of precision which appears in his results.

6. The labours of the ancients in the science of hydrodynamics terminated with the life of Frontinus. The sciences had already begun to decline, and that night of ignorance and barbarism was advancing apace, which for more than a thousand years brooded over the nation of Europe. During this lengthened period of mental degeneracy, when less abstruse studies ceased to attract the notice, and rouse the energies of men, the human mind could not be supposed capable of that vigorous exertion, and patient industry, which are so indispensable in physical researches. Poetry and the fine arts, accordingly had made considerable progress under the patronage of the family of Medici, before Galileo began to extend the boundaries of science. This great man, who deserves to be called the father and restorer of physics, does not appear to have directed his attention to the doctrine of fluids: but his discovery of the uniform acceleration of gravity, laid the foundation of its future progress, and contributed in no small degree to aid the exertions of genius in several branches of science.

7. Castelli and Torricelli, two of the disciples of Galileo, applied the discoveries of their master to the science of hydrodynamics. In 1628 Castelli published

4 T

History. a small work, in which he gave a very satisfactory explanation of several phenomena in the motion of fluids. But he committed a great paralogism in supposing the velocity of the water proportional to the depth of the orifice below the surface of the vessel. Torricelli observing that in a *jet d'eau* where the water rushed through a small adjutage, it rose to nearly the same height with the reservoir from which it was supplied, imagined that it ought to move with the same velocity as if it had fallen through that height by the force of gravity. And hence he deduced this beautiful and important proposition, that the velocities of fluids are as the square roots of the pressures, abstracting from the resistance of the air and the friction of the orifice. This theorem was published in 1643, in his treatise *De Motu Gravium naturaliter accelerato*. It was afterwards confirmed by the experiments of Raphael Magiotti, on the expence of water discharged from different adjutages under different pressure; and though it is true only in small orifices, it gave a new turn to the science of hydraulics.

Of Torricelli.

Of Pascal. 8. After the death of the celebrated Pascal, who discovered the pressure of the atmosphere, a treatise on the equilibrium of fluids was found among his manuscripts, and was given to the public in 1662. In the hands of Pascal, hydrostatics assumed the dignity of a science. The laws of the equilibrium of fluids were demonstrated in the most perspicuous and simple manner, and amply confirmed by experiments. The discovery of Torricelli, it may be supposed, would have incited Pascal to the study of hydraulics. But as he has not treated this subject in the work which has been mentioned, it was probably composed before that discovery had been made public.

Of Mariotte. 9. The theorem of Torricelli was employed by many succeeding writers, but particularly by the celebrated Mariotte, whose labours in this department of physics deserve to be recorded. His *Traité du Mouvement des eaux*, which was published after his death in the year 1686, is founded on a great variety of well conducted experiments on the motion of fluids, performed at Versailles and Chantilly. In the discussion of some points, he has committed considerable mistakes. Others he has treated very superficially, and in none of his experiments does he seem to have attended to the diminution of efflux arising from the contraction of the fluid vein, when the orifice is merely a perforation in a thin plate; but he appears to have been the first who attempted to ascribe the discrepancy between theory and experiment to the retardation of the water's velocity arising from friction. His cotemporary Guglielmini, who was inspector of the rivers and canals in the Milanese, had ascribed this diminution of velocity in rivers, to transverse motions arising from inequalities in their bottom. But as Mariotte observed similar obstructions, even in glass pipes, where no transverse currents could exist, the cause assigned by Guglielmini seemed destitute of foundation. The French philosopher therefore regarded these obstructions as the effects of friction. He supposes that the filaments of water which graze along the sides of the pipe lose a portion of their velocity; that the contiguous filaments having on this account a greater velocity, rub upon the former, and suffer a diminution of their celerity; and that the other filaments are affected with similar retardations proportional to the distance from the axis of the pipe. In this way the medium velocity

of the current may be diminished, and consequently the quantity of water discharged in a given time, must, from the effects of friction, be considerably less than that which is computed from theory. **History.**

10. That part of the science of hydrodynamics which relates to the motion of rivers seems to have originated in Italy. This fertile country receives from the Appennines a great number of torrents, which traverse several principalities before they mingle their waters with those of the Po, into which the greater part of them fall. To defend themselves from the inundations with which they were threatened, it became necessary for the inhabitants to change the course of their rivers; and while they thus drove them from their own territories, they let them loose on those of their neighbours. Hence arose the continual quarrels which once raged between the Bolognese, and the inhabitants of Modena and Ferrara. The attention of the Italian engineers was necessarily directed to this branch of science; and hence a greater number of works were written on the subject in Italy than in all the rest of Europe. **The motion of rivers first attended to in Italy.**

11. Guglielmini was the first who attended to the motion of water in rivers and open canals. Embracing the theorem of Torricelli, which had been confirmed by repeated experiments, Guglielmini concluded that each particle in the perpendicular section of a current has a tendency to move with the same velocity as if it issued from an orifice at the same depth from the surface. The consequences deducible from this theory of running waters are in every respect repugnant to experience, and it is really surprising that it should have been so hastily adopted by succeeding writers. Guglielmini himself was sufficiently sensible that his parabolic theory was contradictory to fact, and endeavoured to reconcile them by supposing the motion of rivers to be obstructed by transverse currents arising from irregularities in their bed. The solution of this difficulty as given by Mariotte was more satisfactory, and was afterwards adopted by Guglielmini, who maintained also that the viscosity of water had a considerable share in retarding its motion. **Theory of Guglielmini.**

12. The effects of friction and viscosity in diminishing the velocity of running water were noticed in the Principia of Sir Isaac Newton, who has thrown much light upon several branches of hydrodynamics. At a time when the Cartesian system of vortices universally prevailed, this great man found it necessary to investigate that absurd hypothesis, and in the course of his investigation he has shown that the velocity of any stratum of the vortex is an arithmetical mean between the velocities of the strata which enclosed it; and from this it evidently follows, that the velocity of a filament of water moving in a pipe is an arithmetical mean between the velocities of the filaments which surround it. Taking advantage of these results, it was afterwards shewn by M. Pitot that the retardations arising from friction are inversely as the diameters of the pipes in which the fluid moves. The attention of Newton was also directed to the discharge of water from orifices in the bottom of vessels. He supposed a cylindrical vessel full of water to be perforated in its bottom with a small hole by which the water escaped, and the vessel to be supplied with water in such a manner that it always remained full at the same height. He then supposed this cylindrical column of water to be divided into two parts; the first being

History.

a hyperboloid generated by the revolution of a hyperbola of the fifth degree around the axis of the cylinder which should pass through the orifice; and the second the remainder of the water in the cylindrical vessel. He considered the horizontal strata of this hyperboloid as always in motion, while the remainder of the water was in a state of rest; and imagined that there was a kind of cataract in the middle of the fluid. When the results of this theory were compared with the quantity of water actually discharged, Newton concluded that the velocity with which the water issued from the orifice was equal to that which a falling body would receive by descending through half the height of water in the reservoir. This conclusion, however, is absolutely irreconcilable with the known fact, that jets of water rise nearly to the same height as their reservoirs, and Newton seems to have been aware of this objection. In the second edition of his Principia, accordingly, which appeared in 1714, Sir Isaac has reconsidered his theory. He had discovered a contraction in the vein of fluid which issued from the orifice, and found that at the distance of about a diameter of the aperture, the section of the vein was contracted in the subduplicate ratio of 2 to 1. He regarded therefore the section of the contracted vein as the true orifice from which the discharge of water ought to be deduced, and the velocity of the effluent water as due to the whole height of water in the reservoir; and by this means his theory became more conformable to the results of experience. This theory however is still liable to serious objections. The formation of a cataract is by no means agreeable to the laws of hydrostatics; for when a vessel is emptied by the efflux of water through an orifice in its bottom, all the particles of the fluid direct themselves toward this orifice, and therefore no part of it can be considered as in a state of repose.

The oscillation of waves first considered by Newton.

13. The subject of the oscillation of waves, one of the most difficult in the science of hydrodynamics, was first investigated by Sir Isaac Newton. By the 44th proposition of the 2d book of his Principia, he has furnished us with a method of ascertaining the velocity of the waves of the sea, by observing the time in which they rise and fall. If the two vertical branches of a syphon which communicate by means of a horizontal branch be filled with a fluid of known density, the two fluid columns when in a state of rest will be in equilibrio and their surfaces horizontal. But if the one column is raised above the level of the other, and left to itself, it will descend below that level, and raise the other column above it; and after a few oscillations, they will return to a state of repose. Newton occupied himself in determining the duration of these oscillations, or the length of a pendulum isochronous to their duration; and he found by a simple process of reasoning, that, abstracting from the effects of friction, the length of a synchronous pendulum is equal to one-half of the length of the syphon, that is, of the two vertical branches and the horizontal one, and hence he deduced the isochronism of these oscillations. From this Newton concluded, that the velocity of waves formed on the surface of water either by the wind or by means of a stone, was in the subduplicate ratio of their size. When their velocity therefore is measured, which can be easily done, the size of the waves will be determined

by taking a pendulum which oscillates in the time that a wave takes to rise and fall.

History.

14. In the year 1718 the Marquis Poleni published at Padua his work *De Castellis per quæ derivantur Fluviorum aquæ, &c.* He found from a great number of experiments, that if A be the aperture of the orifice, and D its depth below the surface of the reservoir, the quantity of water discharged in a given time will be as $2 AD \times \frac{0.571}{1.000}$, while it ought to be as 2 AD, if the velocity of the issuing fluid was equal to that acquired by falling through D. By adapting to a circular orifice through which the water escaped, a cylindrical tube of the same diameter, the marquis found that the quantity discharged in a determinate time was considered greater than when it issued from the circular orifice itself; and this happened whether the water descended perpendicularly or issued in a horizontal direction.

Labours of the Marquis Poleni.

15. Such was the state of hydrodynamics in 1738, when Daniel Bernouilli published his *Hydrodynamica, seu de viribus et motibus Fluidorum Commentarii*. His theory of the motion of fluids was founded on two suppositions, which appeared to him conformable to experience. He supposed that the surface of a fluid, contained in a vessel which was emptying itself by an orifice, remains always horizontal; and if the fluid mass is conceived to be divided into an infinite number of horizontal strata of the same bulk, that these strata remain contiguous to each other, and that all their points descend vertically, with velocities inversely proportional to their breadth, or to the horizontal sections of the reservoir. In order to determine the motion of each stratum, he employed the principle of the *conservatio virium vivarum*, and obtained very elegant solutions. In the opinion of the abbé Bossut, his work was one of the finest productions of mathematical genius.

Daniel Bernouilli's theory of the motion of fluids.

16. The uncertainty of the principle employed by Daniel Bernouilli, which has never been demonstrated in a general manner, deprived his results of that confidence which they would otherwise have deserved; and rendered it desirable to have a theory more certain, and depending solely on the fundamental laws of mechanics. Maclaurin and John Bernouilli, who were of this opinion, resolved the problem by more direct methods, the one in his *Fluxions*, published in 1742; and the other in his *Hydraulica nunc primum detecta, et directè demonstrata ex principis purè mechanicis*, which forms the fourth volume of his works. The method employed by Maclaurin has been thought not sufficiently rigorous; and that of John Bernouilli is, in the opinion of La Grange, defective in perspicuity and precision.

Objected to by Maclaurin and John Bernouilli, who resolve the problem by more direct methods.

17. The theory of Daniel Bernouilli was opposed also by the celebrated D'Alembert. When generalising James Bernouilli's Theory of Pendulums, he discovered a principle of dynamics so simple and general, that it reduced the laws of the motion of bodies to that of their equilibrium. He applied this principle to the motion of fluids, and gave a specimen of its application at the end of his *Dynamics* in 1743. It was more fully developed in his *Traité des Fluides*, which was published in 1744, where he has resolved, in the most simple and elegant manner, all the problems which re-

D'Alembert applies his principle of dynamics to the motion of fluids.

History.

late to the equilibrium and motion of fluids. He makes use of the very same suppositions as Daniel Bernouilli, though his calculus is established in a very different manner. He considers, at every instant, the actual motion of a stratum, as composed of a motion which it had in the preceding instant, and of a motion which it has lost. The laws of equilibrium between the motions lost, furnish him with equations which represent the motion of the fluid. Although the science of hydrodynamics had then made considerable progress, yet it was chiefly founded on hypothesis. It remained a desideratum to express by equations the motion of a particle of the fluid in any assigned direction. These equations were found by D'Alembert, from two principles, that a rectangular canal, taken in a mass of fluid in equilibrium, is itself in equilibrium; and that a portion of the fluid, in passing from one place to another, preserves the same volume when the fluid is incompressible, or dilates itself according to a given law when the fluid is elastic. His very ingenious method was published in 1752, in his *Essai sur la resistance des fluides*. It was brought to perfection in his *Opuscules Mathematiques*, and has been adopted by the celebrated Euler.

Before the time of D'Alembert, it was the great object of philosophers to submit the motion of fluids to general formulæ, independent of all hypothesis. Their attempts, however, were altogether fruitless; for the method of fluxions, which produced such important changes in the physical sciences, was but a feeble auxiliary in the science of hydraulics. For the resolution of the questions concerning the motion of fluids, we are indebted to the method of partial differences, a new calculus, with which Euler enriched the sciences. This great discovery was first applied to the motion of water by the celebrated D'Alembert, and enabled both him and Euler to represent the theory of fluids in formulæ restrained by no particular hypothesis.

Experiments of Michelotti.

18. An immense number of experiments on the motion of water in pipes and canals was made by Professor Michelotti of Turin, at the expence of the sovereign. In these experiments the water issued from holes of different sizes, under pressures of from five to twenty-two feet, from a tower constructed of the finest masonry. Basins built of masonry, and lined with stucco, received the effluent water, which was conveyed in canals of brickwork lined with stucco, of various forms and declivities. The whole of Michelotti's experiments were conducted with the utmost accuracy; and his results are, in every respect, entitled to our confidence.

Of the Abbe Bossut.

19. The experiments of the Abbé Bossut, whose labours in this department of science have been very assiduous and successful, have, in as far as they coincide, afforded the same results as those of Michelotti. Though performed on a smaller scale, they are equally entitled to our confidence, and have the merit of being made in cases which are most likely to occur in practice. In order to determine what were the motions of the fluid particles in the interior of a vessel emptying itself by an orifice, M. Bossut employed a glass cylinder, the bottom of which different adjutages were fitted; and he found that all the particles descend at first vertically, but that at a certain distance from the orifice they turn from their first direction towards the aperture. In consequence of these oblique motions, the fluid vein forms a kind of truncated conoid, whose greatest base is the

History

orifice itself, having its altitude equal to the radius of the orifice, and its bases in the ratio of 3 to 2.—It appears also, from the experiments of Bossut, that when water issues through an orifice made in a thin plate, the expence of water, as deduced from theory, is to the real expence as 16 to 10, or as 8 to 5; and, when the fluid issues through an additional tube, two or three inches long, and follows the sides of the tube, as 16 to 13.—In analyzing the effects of friction, he found, 1. That small orifices gave less water in proportion than great ones, on account of friction; and, 2. That when the height of the reservoir was augmented, the contraction of the fluid vein was also increased, and the expence of water diminished; and by means of these two laws he was enabled to determine the quantity of water discharged, with all the precision he could wish. In his experiments on the motion of water in canals and tubes, he found that there was a sensible difference between the motion of water in the former and the latter. Under the same height of reservoir, the same quantity of water always flows in a canal, whatever be its length and declivity; whereas, in a tube, a difference in length and declivity has a very considerable influence on the quantity of water discharged.—According to the theory of the resistance of fluids, the impulse upon a plane surface, is as the product of its area multiplied by the square of the fluid's velocity, and the square of the sine of the angle of incidence. The experiments of Bossut, made in conjunction with D'Alembert and Condorcet, prove, that this is sensibly true when the impulse is perpendicular; but that the aberrations from theory increase with the angle of impulsion. They found, that when the angle of impulsion was between 60° and 90° , the ordinary theory may be employed, that the resistances thus found will be a little less than they ought to be, and the more so as the angles recede from 90° . The attention of Bossut was directed to a variety of other interesting points, which we cannot stop to notice, but for which, must refer the reader to the works of that ingenious author.

20. The oscillation of waves, which was first discussed by Sir Isaac Newton, and afterwards by D'Alembert, in the article *Ondes*, in the French Encyclopædia, was now revived by M. Flaugergues, who attempted to overthrow the opinions of these philosophers. He maintained, that a wave is not the effect of a motion in the particles of water, by which they rise and fall alternately, in a serpentine line, when moving from the centre where they commenced; but that it is a kind of intumescence, formed by a depression at the place where the impulse is first made, which propagates itself in a circular manner when removing from the point of impulse. A portion of the water, thus elevated, he imagines, flows from all sides into the hollow formed at the centre of impulse, so that the water being, as it were, heaped up, produces another intumescence, which propagates itself as formerly. From this theory, M. Flaugergues concludes, and he has confirmed the conclusion by experiment, that all waves, whether great or small, have the same velocity.

Inquiries of M. Flaugergues concerning the oscillation of waves.

21. This difficult subject has also been discussed by M. de la Grange, in his *Mecanique Analytique*. He de la Grange found, that the velocity of waves, in a canal, is equal to that which a heavy body would acquire by falling through a height equal to half the depth of the water

Hydrostatics. in the canal. If this depth, therefore, be one foot, the velocity of the waves will be 5.495 feet in a second; and if the depth is greater or less than this, their velocity will vary in the subduplicate ratio of the depth, provided it is not very considerable. If we suppose that, in the formation of waves, the water is agitated but to a very small depth, the theory of La Grange may be employed, whatever be the depth of the water and the figure of its bottom. This supposition, which is very plausible, when we consider the tenacity and adhesion of the particles of water, has also been confirmed by experience.

Experiments and theory of the chevalier de Buat. 22. The most successful labourer in the science of hydrodynamics, was the chevalier Buat, engineer in ordinary to the king of France. Following in the steps of the abbé Bossut, he prosecuted the inquiries of that philosopher with uncommon ingenuity; and in the year 1786, he published his *Principes d'Hydraulique*, which contains a satisfactory theory of the motion of fluids founded solely upon experiments. The chevalier du Buat considered, that if water were a perfect fluid, and the channels in which it flowed infinitely smooth, its motion would be continually accelerated, like that of bodies descending in an inclined plane. But as the motion of rivers is not continually accelerated, and soon arrives at a state of uniformity, it is evident that the viscosity of the water, and the friction of the channel in which it descends, must equal the accelerating force. M. Buat, therefore, assumes it as a proposition of fundamental importance, that when water flows in any channel or bed, the accelerating force, which obliges it to move, is equal to the sum of all the resistances which it meets with, whether they arise from its own viscosity or from the friction of its bed. This principle was employed by M. Buat, in the first edition of his work, which appeared in 1779; but the theory contained in that edition was founded on the experiments of others. He soon saw, however, that a theory so new, and leading to results so different from the ordinary theory, should be founded on new experiments more direct than the former, and he was employed in the performance of these from 1780 to 1783. The experiments of Bossut having been made only on pipes of a moderate declivity, M. Buat found it necessary to supply this defect. He used declivities of every kind, from the smallest to the greatest; and made his experiments upon channels, from a line and a half in diameter, or seven or eight square toises. All these experiments he arranged under some circumstances of resemblance, and produced the following proposition, which agrees in a most wonderful manner with the immense number of facts which he has brought together, viz. $V = \frac{307 \times \sqrt{d-0.1}}{\sqrt{s-L} \sqrt{s+1.6}} - 0.3 \times \sqrt{d-0.1}$, where d is the hydraulic mean depth, s the slope of the pipe, or of the surface of the current, and V the velocity with which the water issues. The theory of M. Buat, with its application to practice, will be found in the articles *RIVER* and *WATER-Works*.

23. M. Venturi, professor of natural philosophy in the university of Modena, has lately brought to light some of M. Venturi's curious facts respecting the motion of water, in his work on the "Lateral Communication of Motion in Fluids." He observed, that if a current of water is introduced with a certain velocity into a vessel filled with the same fluid at rest, and if this current passing through a portion of the fluid is received in a curvilinear channel, the bottom of which gradually rises till it passes over the rim of the vessel itself, it will carry along with it the fluid contained in the vessel; so that after a short time has elapsed, there remains only the portion of the fluid which was originally below the aperture at which the current entered. This phenomenon has been called by Venturi, the lateral communication of motion in fluids; and, by its assistance, he has explained many important facts in hydraulics. He has not attempted to explain this principle; but has shewn, that the mutual action of the fluid particles does not afford a satisfactory explanation of it. The work of Venturi contains many other interesting discussions, which are worthy of the attention of every reader.

24. The science of hydrodynamics has of late years been cultivated by M. Eytelwein of Berlin, whose practical conclusions coincide nearly with those of Bossut;—by Dr Matthew Young, late bishop of Clonfert, who has explained the cause of the increased velocity of efflux through additional tubes, and by Mr Vince, Dr T. Young, Coulomb, and Don George Juan; but the limits of this work will not permit us to give any further account of their labours at present. We must now proceed to initiate the reader into the science itself, beginning with that branch of it which relates to the pressure, equilibrium, and cohesion of non-elastic fluids.

PART I. HYDROSTATICS.

Definition of hydrostatics.

25. **HYDROSTATICS** is that branch of the science of hydrodynamics which comprehends the pressure and equilibrium of non-elastic fluids, as water, oil, mercury, &c.; the method of determining the specific gravities of substances, the equilibrium of floating bodies (A), and the phenomena of capillary attraction.

Definitions and Preliminary Observations.

Definition of a fluid.

26. A fluid is a collection of very minute particles, cohering so little among themselves, that they yield to the smallest force, and are easily moved among one another.

Perfect fluids.

27. Fluids have been divided into *perfect* and *imperfect*.

sect. In perfect fluids the constituent particles are supposed to be endowed with no cohesive force, and to be moved one among another by a pressure infinitely small. But, in imperfect or viscous fluids, the mutual cohesion of their particles is very sensible, as in oil, varnish, melted glass, &c.; and this tenacity prevents them from yielding to the smallest pressure. Although water, mercury, alcohol, &c. have been classed among perfect fluids, yet it is evident that neither these nor any other liquid is possessed of perfect fluidity. When a glass vessel is filled with water above the brim, it assumes a convex surface; and when a quantity of it is thrown

Hydrostatics.

thrown on the floor, it is dispersed into a variety of little globules, which can scarcely be separated from one another. Even mercury, the most perfect of all the fluids, is endowed with such a cohesive force among its particles, that if a glass tube, with a small bore, is immersed in a vessel full of this fluid, the mercury will be lower in the tube than the surface of the surrounding fluid;—if a small quantity of it be put in a glass vessel, with a gentle rising in the middle of its bottom, the mercury will desert the middle, and form itself into a ring, considerably rounded at the edges; or if several drops of mercury be placed upon a piece of flat glass, they will assume a spherical form; and if brought within certain limits, they will conglobulate and form a single drop. Now, all these phenomena concur to prove, that the particles of water have a mutual attraction for each other; that the particles of mercury have a greater attraction for one another, than for the particles of glass; and, consequently, that these substances are not entitled to the appellation of perfect fluids.

28. It was universally believed, till within the last 45 years, that water, mercury, and other fluids of a similar kind, could not be made to occupy a smaller space, by the application of any external force. This opinion was founded on an experiment made by Lord Bacon, who inclosed a quantity of water in a leaden globe, and by applying a great force attempted to compress the water into less space than it occupied at first: The water, however, made its way through the pores of the metal, and stood on its surface like dew. The same experiment was afterwards repeated at Florence by the academy del Cimento, who filled a silver globe with water, and hammered it with such force as to alter its form, and drive the water through the pores of the metal. Though these experiments were generally reckoned decisive proofs of incompressibility, yet Bacon himself seems to have drawn from his experiment a very different conclusion; for after giving an account of it, he immediately adds, that *he computed into how much less space the water was driven by this violent pressure* (B). This passage from Lord Bacon does not seem to have been noticed by any writer on hydrostatics, and appears a complete proof that the compressibility of water was fairly deducible from the issue of his experiment. In consequence of the reliance which was universally placed on the result of the Florentine experiment, fluids have generally been divided into compressible and incompressible, or elastic and non-elastic fluids: water, oil, alcohol, and mercury, being regarded as incompressible and non-elastic; and air, steam, and other æriform fluids, as compressible or elastic.

29. About the year 1761, the ingenious Mr Canton began to consider this subject with attention, and distrusting the result obtained by the academy del Cimento, resolved to bring the question to a decisive issue (C). Having procured a small glass tube, about two feet long, with a ball at one end, an inch and a quarter in diameter, he filled the ball and part of the tube with

mercury, and brought it to the temperature of 50° of Fahrenheit. The mercury then stood six inches and a half above the ball; but after it had been raised to the top of the tube by heat, and the tube sealed hermetically, then, upon bringing the mercury to its former temperature of 50°, it stood $\frac{1\frac{1}{2}}{100}$ th of an inch higher in the tube than it did before. By repeating the same experiment with water exhausted of air, instead of mercury, the water stood $\frac{4\frac{1}{2}}{100}$ th of an inch higher in the tube than it did at first. Hence it is evident, that when the weight of the atmosphere was removed, the water and mercury expanded, and that the water expanded $\frac{1\frac{1}{2}}{100}$ th of an inch more than the mercury. By placing the apparatus in the receiver of a condensing engine, and condensing the air in the receiver, he increased the pressure upon the water, and found that it descended in the tube. Having thus ascertained the fact, that water and mercury are compressible, he subjected other fluids to similar experiments, and obtained the results in the following table.

Compression of	Millionth Parts.	Specific Gravity.
mercury,	3	13.595
sea-water,	40	1.028
rain-water,	46	1.000
oil of olives,	48	0.918
spirit of wine,	66	0.846

lest it should be imagined that this small degree of compressibility arose from air imprisoned in the water, Mr Canton made the experiment on some water which had imbibed a considerable quantity of air, and found that its compressibility was not in the least augmented. By inspecting the preceding table, it will be seen that the compressibility of the different fluids is nearly in the inverse ratio of their specific gravities.

30. The experiments of Mr Canton have been lately confirmed by Professor Zimmerman. He found that sea-water was compressed $\frac{1\frac{1}{2}}{100}$ th part of its bulk when inclosed in the cavity of a strong iron cylinder, and under the influence of a force equal to a column of sea-water 1000 feet high. From those facts, it is obvious that fluids are susceptible of contraction and dilatation, and that there is no foundation in nature for their being divided into compressible and incompressible. If fluids are compressible, they will also be elastic; for when the compressing force is removed, they will recover their former magnitude; and hence their division into elastic and non-elastic is equally improper.

31. The doctrines of hydrostatics have been deduced by different philosophers from different properties of fluids. Euler has founded his analysis on the following property, "that when fluids are subjected to any pressure, that pressure is so diffused throughout the mass, that when it remains in equilibrio all its parts are equally pressed in every direction (D)." D'Alembert at first (E) deduced the principles of hydrostatics from the property which fluids have of rising to the same altitude in any number of communicating vessels; but he afterwards

(B) Bacon's works, by Shaw, vol. ii. p. 521. *Novum Organum*, part ii. sect. 2. aph. 45. § 222.

(C) See the Philosophical Transactions for 1762 and 1764, vols liii. and liv.

(D) *Nov. Comment. Petropol.* tom. xiii. p. 305.

(E) *Mélanges de Littérature, d'Histoire, et de Philosophie.*

Florentine experiment.

Compressibility of water first noticed by Lord Bacon.

Fluids divided into compressible and incompressible.

Compressibility of water ascertained by Mr Canton.

Hydrostatics.

Pressure, &c. of Fluids.
 afterwards* adapted the same property as Euler from the foundation which it furnishes for an algebraical calculus. The same property has been employed by Bossut, Prony, and other writers, and will form the first proposition of the following chapter.

Pressure, &c. of Fluids.
 none of the powers A, B, C, D, can yield to the action of the rest. The fluid mass, therefore, will neither change its form nor its situation, and the powers A, B, C, D will be in equilibrio. If the powers A, B, C, D are not equal to one another, nor the orifices mn, op, rs, tu ; but if $A : B = mn : op$, and so on with the rest, the fluid will still be in equilibrio. Let A be greater than B, then mn will be greater than op ; and whatever number of times B is contained in A, so many times will op be contained in mn . If $A = 2B$, then $mn = 2op$, and since the orifice mn is double of op , the pressure upon it must also be double; and, in order to resist that pressure, the power A must also be double of B; but, by hypothesis, $A = 2B$, consequently the pressures upon the orifices, or the powers A, B, will be in equilibrio. If the power A is any other multiple of B, it may be shewn in the same way that the fluid will be in equilibrio.

* Traité des Fluides, § 20.

CHAP. I. On the Pressure and Equilibrium of Fluids.

PROPOSITION I.

32. WHEN a mass of fluid, supposed without weight, is subjected to any pressure, that pressure is so diffused throughout the whole, that when it remains in equilibrio all its parts are equally pressed in every direction.

The parts of a fluid subjected to any pressure, are equally pressed in every direction.
 As it is the distinguishing property of fluids that their particles yield to the smallest pressure, and are easily moved among themselves (16.), it necessarily follows, that if any particle is more pressed towards one side than towards another, it will move to that side where the pressure is least; and the equilibrium of the fluid mass will be instantly destroyed. But by the hypothesis the fluid is in equilibrio, consequently the particle cannot move towards one side, and must therefore be equally pressed in every direction.

Plate CCLXIII. § 1.
 In order to illustrate this general law, let EF (fig. 1.) be a vessel full of any liquid, and let mn, op be two orifices at equal depths below its surface; then, in order to prevent the water from escaping, it will be necessary to apply two pistons, A and B, to the orifices mn, op with the same force, whether the orifice be horizontal or vertical, or in any degree inclined to the horizon; so that the pressure to which the fluid mass is subject, which in this case is its own gravity, must be distributed in every direction. But if the fluid has no weight, then the pressure exerted against the fluid at the orifice op , by means of the piston B, will propagate itself through every part of the circular vessel EF, so that if the orifices mn, tu are shut, and rs open, the fluid would rush through this aperture in the same manner as it would rush through mn or tu , were all the other orifices shut. This proposition, however, is true only in the case of perfect fluids; for when there is a sensible cohesion between the particles, as in water, an equilibrium may exist even when a particle is less pressed in one direction than in another; but this inequality of pressure is so exceedingly trifling, that the proposition may be considered as true, even in cases of imperfect fluidity.

PROP. II.

Fig. 1.
 33. If to the equal orifices mn, tu, op, rs of a vessel, containing a fluid destitute of weight, be applied equal powers A, B, C, D, in a perpendicular direction, or if the orifices mn , &c. be unequal, and the powers A, B, &c. which are respectively applied to them be proportional to the orifices, these powers will be in equilibrio.

It is evident from the last proposition, that the pressure exerted by the power B is transmitted equally to the orifices mn, rs, tu , that the pressure of the power C is transmitted equally to the orifices mn, op, tu , and so on with all the other powers. Every orifice then is influenced with the same pressure, and, consequently,

PROP. III.

34. The surface of a fluid influenced by the force of gravity and in equilibrio in any vessel, is horizontal, or at right angles to the direction of gravity.

The surface of fluids horizontal. Fig. 2.
 Let the surface of the fluid be supposed to assume the waving form APEB. Any particle P in the surface of the fluid is influenced by the force of gravity, which may be represented by PS, and which may be decomposed into two forces Pm, Pn in the direction of the two elementary portions of the surface Pm, Pn, (see DYNAMICS, 148). But since the particle P is in a state of equilibrio, the force of gravity acting in the direction Pm, Pn must be destroyed by equal and opposite forces, exerted by the neighbouring particles against P in the direction mP, nP; therefore the forces Pm, Pn are equal to the forces mP, nP. Now the particle P being in equilibrio, must be equally pressed in every direction (32.). Wherefore the forces Pm, Pn are equal, and by the doctrine of the composition of forces (see DYNAMICS, 133. D), the angle mPn formed by the two elementary portions Pm, Pn of the surface of the fluid, must be bisected by PS, the line which represents the direction of gravity. The same may be proved of every other point of the surface of the fluid; and therefore this surface must be horizontal or perpendicular to the direction of gravity.

35. This proposition may be otherwise demonstrated. From the principles of mechanics, it is obvious, that when the centre of gravity of any body is at rest, the body itself is at rest; and that when this centre is not supported, the body itself will descend, till it is prevented by some obstacle from getting farther. In the same manner the centre of gravity of a fluid mass will descend to the lowest point possible; and it can be shewn that this centre will be in its lowest position when the surface of the fluid mass is horizontal. For let FGHI (fig. 2.) be any surface, whether solid or fluid, and C its centre of gravity, the point C is nearer the line HI when FG is parallel to HI and rectilinear, than when it has any other form or position. When the surface FGHI is suspended by the point C, or balanced upon it, it will be in equilibrio; but if the line F is made to assume any other form as F'rsG, by removing the portion Gop of the surface to F'rs, the equilibrium

Pressure,
&c. of
Fluids.

equilibrium will be destroyed, and the side FG will preponderate. In order, therefore, to restore the equilibrium, the surface must be balanced on a point c farther from HI ; that is, the centre of gravity of the surface *Frstop* IH is c . In the same way it may be shewn, that whatever be the form of the bounding line FG , the quantity of surface remaining the same, its centre of gravity will be nearest HI , when FG is rectilinear and parallel to it.—On the truth contained in this proposition depends the art of levelling, and the construction of the spirit level, for an account of which see **LEVELLING**.

36. As the direction of gravity is in lines which meet near the centre of the earth; and as it appears from this proposition, that the surface of fluids is perpendicular to that direction, their surface will be a portion of a spheroid similar to the earth. When the surface has no great extent, it may be safely considered as a plane; but when it is pretty large, the curvature of the earth must be taken into the account.

PROP. IV.

37. The surface of a fluid influenced by the force of gravity, and contained in any number of communicating vessels, however different in form and position, will be horizontal.

The surface of a fluid in any number of communicating vessels is horizontal.
Fig. 3.

Let $ABCDE$ be a system of communicating vessels into which a quantity of fluid is conveyed: It will rise to the same height in each vessel, and have a horizontal surface $ABCDE$. Suppose $AGFE$, a large vessel full of water. By the last proposition, its surface $ABCDE$ will be horizontal. Now, if any body be plunged into this vessel, the cylinder C for instance, the surface of the fluid will still be horizontal; for no reason could be assigned for the water's rising on one side of this body any more than on another. Let us now take out the cylinder C , and immerse into the fluid, successively, the solid bodies Aa , Bb , Cc , Dd , then after each immersion the surface will still be horizontal; and when all these solids are immersed, the large vessel AF will be converted into the system of communicating vessels represented in fig. 4.; in which the surface of the fluid will, of consequence, be horizontal.

Fig. 4.

38. This proposition may be also demonstrated by supposing the parts Aa , Bb , Cc , Dd , converted into ice without changing their former magnitude. When this happens, the equilibrium will not be disturbed; and the fluid mass AF , whose surface was proved to be horizontal by the last proposition, will continue in the same state after the congelation of some of its parts. That is, the surface of the fluid in the communicating vessels A , B , C , D , E will be horizontal.

This proposition is not true when the communicating vessels are capillary tubes.

39. When the communicating vessels are so small that they may be regarded as capillary tubes, the surface of the fluid will not be horizontal. From the attraction which all fluids have for glass, they rise to a greater height in smaller tubes than in larger ones, and the quantity of elevation is in the inverse ratio of the diameters of the bores. In the case of mercury, and probably of melted metals, the fluid substance is depressed in capillary tubes, and the depression is subject to the same law. The subject of capillary attraction

will be treated at length in a subsequent part of this article.

Pressure
&c. of
Fluids.

40. This proposition explains the reason why the surface of small pools in the vicinity of rivers is always on a level with the surface of the rivers themselves, when there is any subterraneous communication between the river and the pool. The river and the pool may be considered as communicating vessels.

PROP. V.

41. If a mass of fluid contained in a vessel be in equilibrio, any particle whatever is equally pressed in every direction, with a force equal to the weight of a column of particles whose height is equal to the depth of the particle pressed below the surface of the fluid.

Immerse the small glass tube mp , into the vessel AB Fig. 5 filled with any fluid; then if the tube is not of the capillary kind, the fluid will rise to n on the same level with the surface AB of the fluid in the vessel. Now it is evident, that the particle p at the bottom of the tube mp is pressed downwards by the superincumbent column of particles np , which is equal to the depth of the particle p below the surface of the fluid. But since the mass of fluid is in equilibrio, the particle p is pressed equally in every direction: Therefore, the particle p is pressed equally in every direction by a force equal to the superincumbent column np .

PROP. VI.

42. A very small portion of a vessel of any form, filled with a fluid, is pressed with a force which is in the compound ratio of the number of particles contained in that surface, its depth below the surface of the fluid, and the specific gravity of the fluid.

Let $DpEB$ be the vessel, and rs a very small portion of its surface, the pressure upon rs is in the compound ratio of the number of particles in rs , and np its depth below the horizontal surface DB . Suppose the glass tube mp to be inserted in the infinitely small aperture p , then, abstracting from the influence of capillary attraction, the fluid in the glass tube will ascend to m on a level with DB , the surface of the fluid in the vessel, and the particle p will be pressed with a column of particles, whose height is np . In the same way it may be shewn, that every other particle contained between r and s is pressed with a similar column. Then, since $p \times np$ will represent the pressure of the column np on the particle p ; if N be the number of particles in the space rs , $N \times np$ will be the force of the column supported by the space rs . And as the weight of this column must increase with the specific gravity of the fluid, $S \times N \times np$ will represent its pressure, S being the specific gravity of the fluid.

PROP. VII.

43. The pressure upon a given portion of the bottom of a vessel, whether plane or curved, filled with

any

Pressure,
&c. of
Fluids.

any fluid, is in the compound ratio of the area of that portion, and the mean altitude of the fluid, that is, the perpendicular distance of the centre of gravity of the given portion from the surface of the fluid; or, in other words, the pressure is equal to the weight of a column of fluid whose base is equal to the area of the given portion, and whose altitude is the mean altitude of the fluid.

Pressure,
&c. of
Fluids.

For since the fluid in the two communicating vessels AB, CD will rise to the same level, whatever be their size, the fluid in AB evidently balances the fluid in CD; and any surface *mn* is pressed with the same force in the direction *Bm* by the small column AB, as it is pressed in the direction *Dm* by the larger column CD.

46. COR. 1. From this proposition it follows that the whole pressure on the sides of a vessel which are perpendicular to its base, is equal to the weight of a rectangular prism of the fluid, whose altitude is that of the fluid, and whose base is a parallelogram, one side of which is equal to the altitude of the fluid, and the other to half the perimeter of the vessel.

COR. 2. The pressure on the surface of a hemispherical vessel full of fluid, is equal to the product of its surface multiplied by its radius.

COR. 3. In a cubical vessel the pressure against one side is equal to half the pressure against the bottom; and the pressure against the sides and bottom together, is to that against the bottom alone as three to one. Hence, as the pressure against the bottom is equal to the weight of the fluid in the vessel, the pressure against both the sides and bottom will be equal to three times that weight.

COR. 4. The pressure sustained by different parts of the side of a vessel are as the squares of their depths below the surface; and if these depths are made the abscissa of a parabola, its ordinate will indicate the corresponding pressures.

DEFINITION.

Definition.

47. The centre of pressure is that point of a surface exposed to the pressure of a fluid, to which if the total pressure were applied, the effect upon the plane would be the same as when the pressure was distributed over the whole surface: Or, it is that point to which if a force equal to the total pressure were applied in a contrary direction, the one would exactly balance the other, or, in other words, the force applied and the total pressure would be *in equilibrio*.

PROP. VIII.

48. The centre of pressure coincides with the centre of percussion.

Let AB be a vessel full of water, and CE the section of a plane whose centre of pressure is required. Prolong CE till it cuts the surface of the water in M. Take any point D, and draw DO, EP, CN perpendicular to the surface MP. Then if M be made the axis of suspension of the plane CE, the centre of percussion of

Fig. 5.

LET AEGB be the vessel, and AFB the surface of the fluid which it contains. Let GH be a given portion of its bottom, and C the centre of gravity of that portion: Then shall CF be the mean altitude of the fluid.—Conceive the portion GH to be divided into an infinite number of small elements *Hh*, *Gg*, &c. then (42.) the pressure sustained by the elements *Hh*, *Gg*, will be respectively $S \times Hh \times Hw$; $S \times Gg \times Gt$, &c. the specific gravity of the fluid being called *S*. But it follows from the nature of the centre of gravity, that the sum of all these products is equal to the product of the whole portion GH into CF the distance of its centre of gravity from the horizontal surface of the fluid (*r*). Therefore the pressure upon the portion GH is in the compound ratio of its surface converted into a plane, and the mean altitude of the fluid.

Hydrostatic paradox.

44. From this proposition we may deduce what is generally called the *Hydrostatic paradox*, viz. that the pressure upon the bottoms of vessels filled with fluid does not depend upon the quantity of fluid which they contain, but upon its altitude; or, in other words, that any quantity of fluid, however small, may be made to balance any quantity or any weight, however great. Let ACOQRFDB be a vessel filled with water, the bottom QR will sustain the same pressure as if it supported a quantity of water equal to MQRN. It is evident (43.) that the part EF is pressed with the column of fluid ABEF, and that the part DG equal to CD is pushed upwards with the weight of a column equal to ABCD. Now, as action and reaction are equal and contrary, the part DG reacts upon FH with a force equal to the weight of the column ABCD, and FH evidently sustains the smaller column DGFH; therefore FH sustains a pressure equal to the weight of the two columns ABCD and DGFH, that is, of the column BIHF. In the same way it might be shewn, that any other equal portion of the bottom QR sustains a similar pressure; and therefore it follows, that the pressure upon the bottom QR is as great as if it supported the whole column MNQR.

Fig. 6.

45. The same truth may be deduced from Prop. IV.

Fig. 7.

(*r*) This will be evident from the following proposition. If every indefinitely small part of a surface be multiplied by its perpendicular distance from a given plane, the sum of the products will be equal to the product of the whole surface, multiplied by the perpendicular distance of its centre of gravity from the same plane. In Plate CCLXIII. fig. 7. let *a*, *c* represent two weights suspended at their centre of gravity by the lines *aA*, *cC* attached to the horizontal plane of which ABC is a section, and let *b* be the common centre of gravity of these weights and *bB* the distance of this centre from the given plane, then $a \times aA + c \times cC = a + c \times bB$.—Draw *an*, *cm* at right angles to *bB*. Then since *b* is the common centre of gravity of the weights *a*, *c*, we shall have by the similar triangles *anb*, *cmb* (Euclid VI. 4.) $nb : mb = (ba : bc) : a$ (See MECHANICS, Centre of Gravity). Hence $a \times nb = c \times mb$, or $a \times nb - bB = c \times mb - mB$, or $a \times nb - a \times bB = c \times mb - c \times mB$; then by transposition, $a \times nb - c \times mB = a \times bB + c \times mb = a + c \times bB$. But $aB = aA$ and $mB = cC$, therefore, by substitution $a \times aA + c \times cC = a + c \times bB$. By supposing the two weights *a* and *c* united in their common centre of gravity, the same demonstration may be extended to any number of weights.

Pressure,
&c. of
Fluids.

of the plane CE revolving round M will also be the centre of pressure. If MCE moves round M as a centre, and strikes any object, the percussive force of any point C is as its velocity, that is, as its distance CM from the centre of motion; therefore the percussive force of the points C, D, E, are as the lines CM, DM, EM. But the pressures upon the point C, D, E, are as the lines CN, DO, EP, and these lines are to one another as CM, DM, EM; therefore the percussive forces of the points C, D, E, are as the pressures upon these points. Consequently, the centre of pressure will always coincide with the centre of percussion.

SECT. II. Instruments and Experiments for illustrating the Pressure of Fluids.

Machine
for illustrating
the hydrostatic
paradox.

Plate
CCLXIV.
Fig. 1.

49. WE have already shewn in art. 41. that the pressure upon the bottoms of vessels filled with fluids does not depend upon the quantity of fluid which they contain, but upon its particular altitude. This proposition has been called the Hydrostatical Paradox, and is excellently illustrated by the following machine. In fig. 1. AB is a box which contains about a pound of water, and *a b c d* a glass tube fixed to the end C of the beam of the balance, and the other end to a moveable bottom which supports the water in the box, the bottom and wire being of an equal weight with an empty scale hanging at the other end of the balance. If one pound weight be put into the empty scale, it will make the bottom rise a little, and the water will appear at the bottom of the tube *a*, consequently it will press with a force of one pound upon the bottom. If another pound be put into the scale, the water will rise to *b*, twice as high as the point *a*, above the bottom of the vessel. If a third, a fourth, and a fifth pound be put successively into the scale, the water will rise at each time to *c*, *d*, and *e*, the divisions *ab*, *bc*, *cd*, *de* being all equal. This will be the case, however small be the bore of the glass tube; and since when the water is at *b*, *c*, *d*, *e*, the pressures upon the bottom are successively twice, thrice, four times, and five times as great as when the water was contained within the box, we are entitled to conclude that the pressure upon the bottom of the vessel depends altogether on the altitude of the water in the glass tube, and not upon the quantity it contains. If a long narrow tube full of water, therefore, be fixed in the top of a cask likewise full of water, then though the tube be so small as not to hold a pound of the fluid, the pressure of the water in the tube will be so great on the bottom of the cask as to be in danger of bursting it; for the pressure is the same as if the cask was continued up in its full size to the height of the tube, and filled with water. Upon this principle it has been affirmed that a certain quantity of water, however small, may be rendered capable of exerting a force equal to any assignable one, by increasing the height of the column, and diminishing the base on which it presses. This, however, has its limits; for when the tube becomes so small as to belong to the capillary kind, the attraction of the glass will support a considerable quantity of the water it contains, and therefore diminish the pressure upon its base.

The smallest
quantity
of water
may exert
a force e-
qual to any
assignable
one.

Construc-
tion of the
preceding
machine.
Fig. 2.

50. The preceding machine must be so constructed, that the moveable bottom may have no friction against the inside of the box, and that no water may get be-

tween it and the box. The method of effecting this will be manifest from fig. 2. where ABCD is a section of the box, and *a b c d* its lid, which is made very light. The moveable bottom E, with a groove round its edges, is put into a bladder *fg*, which is tied close around it in the groove, by a strong waxed thread. The upper part of the bladder is put over the top of the box at *a* and *d* all around, and is kept firm by the lid *a b c d*, so that if water be poured into the box through the aperture *ll* in its lid, it will be contained in the space *f E g h*, and the bottom may be raised by pulling the wire *i* fixed to it at E.

51. The upward pressure of fluids is excellently illustrated by the hydrostatic bellows. The form given to this machine by the ingenious Mr Ferguson (*Lectures*, vol. ii. p. 111.) is represented in fig. 3. where ABCD is an oblong square box, into one of whose sides is fixed the upright glass tube *a I*, which is bent into a right angle at the lower end as at *s*, fig. 4. To this bent extremity is tied the neck of a large bladder K, which lies in the bottom of the box. Over this bladder is placed the moveable board L, figs. 3. and 4. in which the upright wire M is fixed. Lead weights NN, with holes in their centre, to the amount of 16 pounds, are put upon this wire, and press with all their weight upon the board L. The cross bar *p* is then put on, in order to keep the glass tube in an upright position; and afterwards the piece EFG for keeping the weights NN horizontal, and the wire M vertical. Four upright pins, about an inch long, are placed in the corners of the box, for the purpose of supporting the board L, and preventing it from pressing together the sides of the bladder. When the machine is thus fitted up, pour water into the tube I till the bladder is filled up to the board L. Continue pouring in more water, and the upward pressure which it will excite in the bladder will raise the board with all the weights NN, even though the base of the tube should be so small as to contain no more than an ounce of water.

52. That the pressure of fluids arises from their gravity, and is propagated in every direction, may be proved by the following experiment. Insert into an empty vessel, a number of glass tubes bent into various angles. Into their lower orifices introduce a quantity of mercury, which will rest in the longer legs on a level with these orifices. Let the vessel be afterwards filled with water; and it will be seen, while the vessel is filling, that the mercury is gradually pressed from the lower orifices towards the higher, where the water is prevented from entering. Now, in consequence of the various angles into which the glass tubes are bent, the lower orifices point to almost every direction; and therefore it follows, that the pressure of the superincumbent water is propagated in every direction. When a straight tube is employed to shew the upward pressure of fluids, the mercury which is introduced into its lower extremity must be kept in by the finger till the height of the water above the orifice is equal to fourteen times the length of the column of quicksilver: When the finger is removed the mercury will ascend in the tube.

53. The pressure of the superior strata of fluids upon the interior strata may be shown in the following manner. Immerse two tubes of different bores, but not of the capillary kind, in a vessel of mercury. The mercury will rise in the tube on a level with its surface

Pressure
&c. of
Fluids.

The up-
ward pres-
sure of
fluids illu-
strated by
the hydro-
static bellows.
Fig. 3. 4.
5.

Experiment
for shew-
ing that the
pressure of
fluids arises
from their
gravity, and is
propagated
in every di-
rection.

Experiment
for shew-
ing that the
superior
strata of
fluids press
upon the
inferior
strata of
fluids.

Pressure,
&c. of
Fluids.

Pressure,
&c. of
Fluids.

in the vessel. Let water then be poured upon the mercury so as not to enter the upper orifices of the tubes, the pressure of the water upon the inferior fluid will cause the mercury to ascend in the tubes above the level of that in the vessel, but to the same height in both tubes. The columns of quicksilver in the two tubes are evidently supported by the pressure of the water on the inferior fluid. The same experiment may be made with oil and tinged water, the latter being made the inferior fluid.

through the syphon *a c d* into the cup *b*, until a perfect equilibrium is obtained by an equality between the columns of water *a e* and *h b*.

Description
of the sy-
phon.
Fig. 6.

54. The syphon is an instrument which shews the gravitation of fluids, and is frequently employed for decanting liquors. It is nothing more than a bent tube EABCF, having one of its legs longer than the other. The shorter leg BCF is immersed in the fluid contained in the vessel D; and if, by applying the mouth to the orifice E, the air be sucked out of the tube, the water in the vessel D will flow off till it be completely emptied. Now it is obvious that the atmosphere which has a tendency to raise the water in the shorter leg EB by its pressure on the surface of the water at C, has the same tendency to prevent the water from falling from the orifice E, by its pressure there, and therefore if the syphon had equal legs as AB, BC, no water could possibly issue from the orifice E. But when the leg EB is longer than BC, the column of fluid which it contains being likewise longer, will by its superior weight cause the water to flow from the orifice E, and the velocity of the issuing fluid will increase as the difference between the two legs of the syphon is made greater.

SECT. III. Application of the Principles of Hydrostatics to the Construction of Dykes, &c. for resisting the pressure of water.

DEFINITION.

Definition.

A dyke is an obstacle either natural or artificial, which opposes itself to the constant effort of water to spread itself in every direction.

56. In discussing this important branch of hydraulic architecture, we must inquire into the thickness and form which must be given to the dyke in order to resist the pressure of the water. In this inquiry the dyke may be considered as a solid body which the water tends to overthrow by turning it round upon its posterior angle C; or it may be regarded as a solid, whose foundation is immovable, but which does not resist the pressure of the water through the whole of its height, and which may be separated into horizontal sections by the efforts of the fluid. A dyke may be considered also as a solid body which can be neither broken nor overturned, but which may be pushed horizontally from its base, and can preserve its stability only by the friction of its base on the ground which supports it. On these conditions are founded the calculations in the following propositions which contain the most useful information that theory can suggest upon the construction of dykes.

PROP. I.

Experiment
for shewing
that the ef-
fect of the
syphon de-
pends on
the gravi-
tation of
fluids.
Fig. 7.

55. In order to shew that the effect of the syphon depends upon the gravitations of fluids, M. Pascal devised the following experiment. In the large glass vessel AB, fasten by means of bees wax two cylindrical cups *a, b*, containing tinged water, whose surface is about an inch higher in the one than in the other. Into the tinged water insert the legs of a glass syphon *c d*, having an open tube *e* fixed into the middle of it, and put a wooden cover on the vessel with a hole in its centre to receive the tube and keep it in a vertical position. Then through the funnel *f*, fixed in another part of the cover, pour oil of turpentine into the larger vessel till it flow into the cups *a, b*, and rise above the arch of the syphon. The pressure of the oil upon the tinged water in the cups will cause the water to pass through the syphon from the higher cup to the lower, till the surfaces of the water in both the cups be reduced to a level. In order to explain this, suppose a horizontal plane *e b* to pass through the legs of the syphon, and the tinged water in the cups, the parts of this plane within the legs when the syphon is full, will be equally pressed by the columns of tinged water *o e, d b* within the syphon; but the equal parts of this plane between the circumference of each leg of the syphon, and the circumference of each cylindrical cup, their diameters being equal, will sustain unequal pressures from their superincumbent columns, through the altitudes of these columns be equal. For since the pressure upon *e* is exerted by a column of oil *a c*, and a column of water *a e*, whereas the pressure upon *b* is exerted by a column of oil *h d*, and a column of water *h b*; the column *c e* which contains the greatest quantity of water, will evidently exert the greatest force, and by its pressure will drive the tinged water from the cup *a*,

57. To find the dimensions of a dyke which the water tends to overthrow by turning it round its posterior angle.

Let ABCD be the section of the dyke, considered as a continuous solid, or a piece of firm masonry, HK the level of the water which tends to overthrow it by turning it round its posterior angle C, supposed to be fixed, and let AC, BD, be right lines or known curves. It is required to determine CD the thickness which must be given to its base to prevent it from being overturned.

To the surface of the water HK draw the ordinates PM, *p m* infinitely near each other, and let fall from the points H and M the perpendiculars, HT, MX. Draw the horizontal line ML and raise the perpendicular CL, and suppose

- HP = *s*
- PM = *y*
- P *p* or MV the fluxion of *s* = *s*
- V *m* the fluxion of *y* = *y*
- HT = *a*
- DT = *b*
- CD = *x*
- The momentum of the area ABCD, or the force with which it resists being turned round the fulcrum C = *Z*
- The specific gravity of water = *s*
- The specific gravity of the dyke = *e*

58. It is obvious from art. 41. that every element sustains a perpendicular pressure proportional to the height PM. Let RM perpendicular to M *m* represent the force

Pressure
&c. of
Fluids.

Pressur
&c. of
Fluids.

force exerted by the column of water $M m p P$, and let it be decomposed into two other forces, one of which RQ is horizontal, and has a tendency to turn the dyke round the point C , and the other RY is vertical and tends to press the dyke upon its base. The force RQ is evidently $= s \times y \times M m$, (42.) and therefore the horizontal part of it will be only $sy \times M m \times \frac{RQ}{RM}$. But the triangles RQM, MVm are evidently similar, consequently $RQ : RM = V m : M m$; hence $\frac{RQ}{RM} = \frac{V m}{M m} = \frac{y}{M m}$.

Wherefore by substitution we have the force $RQ = sy \times M m \times \frac{y}{M m}$, and dividing by $M m$, we have $RQ = sy y$. The force RQ , therefore, will always be the same as the force against $V m$, whatever be the nature of the curve BD . Now the momentum of this force with relation to the fulcrum C , or its power to make the dyke revolve round C , is measured by the perpendicular CL let fall from the centre of motion to the direction in which the force is exerted (See MECHANICS), consequently this momentum will be $sy y \times CL = sy y \times a - y$ (since $CL = HT - PM = a - y$) $= sayy - sy y y$, whose fluent is $\frac{s a y y}{2} - \frac{s y^3}{3}$, which by supposing $y = a$ becomes $\frac{1}{2} s a^3$ for the total momentum of the horizontal effort of the water to turn the dyke round C . The vertical force RY or QM , which presses the dyke upon its base, is evidently $sy \times M m \times \frac{MQ}{RM}$, but

on account of the similar triangles $\frac{MQ}{RM} = \frac{x}{M m}$, consequently by substitution we shall have the force $RY = sy \times M m \times \frac{x}{M m} = sy x$, after division by $M m$. The momentum, therefore, of the vertical force RY with relation to C , or its power to prevent the dyke from moving round the fulcrum C , will be $sy x \times CX$; CX being the arm of the lever by which it acts, or the perpendicular let fall from the fulcrum upon the direction of the force. Now $CX = CD - DT + TX$ or HP , that is $CX = x - b + x$, therefore the momentum of the force $RY = sy x \times x - b + x$, and the sum of the similar momenta from F to H will be the fluent $\int (x - b + x) sy x$,

the combined momentum of all the vertical forces which resist the efforts of the horizontal forces to turn the dyke round C . But the efforts of the horizontal forces are also resisted by the weight of the dyke whose momentum we have called Z , therefore σZ , σ being the specific gravity of the dyke, will be the momentum of the dyke. We have now three forces acting at once, viz. the horizontal force of the water striving to overturn the dyke, and the vertical force of the water combined with the momentum of the dyke, striving to

resist its overthrow, therefore we shall have an equilibrium between these three forces, when the momentum of the horizontal forces is made equal to the momentum of the vertical forces, added to that of the dyke itself, consequently

$$\frac{1}{2} s a^3 = \int (x - b + x) sy x + \sigma Z.$$

59. As it is necessary, however, to give more stability to the dyke than what is just requisite to preserve its equilibrium, we must make its dimensions such as to resist a force greater than the horizontal forces, a force, for example, n times the momentum of the horizontal forces (G). The equation will therefore become

$$(L) n \times \frac{1}{2} s a^3 = \int (x - b + x) sy x + \sigma Z,$$

which comprehends every possible case of stability; for if we wish the stability of the dyke to have double the stability of equilibrium, we have only to make $n = 2$. The preceding general equation is susceptible of a variety of applications according to the nature of the curves which form the sides of the dyke. It is at present worthy of remark that since the momentum of the horizontal forces is always the same whatever be the curvature of the sides AC, BD , and since the momentum of the vertical forces increases as the angle CDH diminishes, it follows that it will always be advantageous to diminish the angle CDH and give as much slope as possible to the sides of the dyke.

60. Let us now consider the conditions that may be necessary to prevent the dyke $ABCD$ from sliding on its base CD . Since the base of the dyke is supposed horizontal, the force which the dyke opposes to the horizontal efforts of the water arises solely from the adhesion of the dyke to its base, and from the resistance of friction. These two forces, therefore, combined with the weight of the dyke, form the force which resists the horizontal efforts of the water; an equilibrium will consequently obtain when the three first forces are made equal to the last. But the force of adhesion, and the resistance of friction, being unknown, may be made equal to the weight of the dyke multiplied by the constant quantity m , which must be determined by experience. Now calling A the area of the section $ABCD$, we shall have σA for its weight, and $m \sigma A$ for the resistance which is opposed to the horizontal efforts of the water. But we have already seen that the horizontal forces of the water upon M are equal to $sy y$, whose fluent $\frac{1}{2} s a^3$ (when $a = y$) is the sum of all the horizontal forces, consequently when an equilibrium takes place between these opposing forces we shall have

$$(II) m \sigma A = \frac{1}{2} s a^3, \text{ or } A = \frac{s}{\sigma} \times \frac{a^3}{2 m}.$$

We might have added to the weight of the dyke the vertical pressure of the water, but it has been neglected for the purpose of having the dyke sufficiently strong to resist an additional force.

61. We

(G) The dimensions of the dyke would be sufficiently strong to resist any additional force by neglecting the term σZ , which represents the vertical pressure of the water tending to keep the dyke upon its base.

Pressure, &c. of Fluids. sides is therefore to its area with vertical sides nearly as 4 to 5: and hence we may conclude that a dyke with inclined sides has the same stability as a dyke with vertical sides; while it requires $\frac{1}{3}$ less materials.

2. The momentum of the part AMN of the dyke will be $= \sigma \int x y$ the area of the surface AMN, multiplied by the distance of its centre of gravity from the fulcrum N, which is equal to $\frac{\int x x y}{\int x y}$ See MECHANICS.

Pressure, &c. of Fluids.

PROP. II.

To find the dimensions of the dyke when the water tends to separate it into horizontal sections or laminae. 66. To find the dimensions of a dyke which can neither slide upon its base, nor turn round its posterior angle; but which is composed of horizontal sections which may be separated from each other.

68. In order to simplify the calculus, and at the same time increase the stability of the dyke, we shall neglect the vertical force of the water, and the adhesion of the two surfaces MN, $m n$. The only forces therefore which we have to consider, are the horizontal efforts of the water acting against the momentum of the superior part AMN. By making an equilibrium between these forces we shall have the following equation

In solving this proposition we must find the curvature of the side exposed to the pressure of the water, which will make all the different sections or horizontal laminae equally capable of resisting the different forces which tend to separate them. If the lamina NM does not resist the column PM, which partly presses it in the direction MN as powerfully as the lamina $n m$ resists the horizontal pressure of the column $p m$, the lamina NM is in danger of being separated from the lamina $n m$. But if all the laminae NM, $n m$ resist with equal force the horizontal effects of the water, and if the dyke cannot be made to slide upon its base nor turn round its posterior angle T, it cannot possibly yield to the pressure of the water; for it is impossible to separate one lamina from another, unless the one opposes a less resistance than the other. To simplify the investigation as much as possible, let us suppose the posterior side of the dyke to be vertical, and the depth of the water to be equal to the height of the dyke.

$$\frac{1}{3} s y^2 = \sigma \int x y \times \frac{\int x x y}{\int x y} = \frac{1}{3} \sigma \times \int x x y$$

By taking the fluxion we have

$$\frac{1}{3} s y^2 \dot{y} = \frac{1}{3} \sigma \times x x \dot{y}$$

Dividing by \dot{y} we have $\frac{1}{3} s y^2 = \frac{1}{3} \sigma \times x^2$, which by reduction becomes $y = \sqrt{\frac{\sigma}{s}} \times x$.

The line AMC therefore is rectilinear, and the base BC is to the altitude BA as $\sqrt{s} : \sqrt{\sigma}$; that is, as the square root of the specific gravity of the water is to the square root of the specific gravity of the dyke.

69. In order to prevent the superior portion AMN from sliding on its base MN, we must procure an equilibrium between the adhesion of the surfaces MN, $m n$ and the horizontal force exerted by the water. Now the sum of all the horizontal forces exerted by the water is (by art. 58.) $\frac{1}{3} s y^2$, and the adhesion may be represented by some multiple m , of its weight, the constant quantity m being determined by experience. The adhesion will therefore be $m \times \sigma \int x y$, and the equation of equilibrium will be

$$\frac{1}{3} s y^2 = m \times \sigma \int x y$$

the fluxion of which is $s y \dot{y} = m \times \sigma x \dot{y}$ Dividing by \dot{y} we have $s y = m \sigma x$, and therefore $x : y = s : m \sigma$.

Hence the base BC of the dyke is to its altitude BA as the specific gravity of water is to a multiple m of the specific gravity of the dyke, m being a constant quantity which experiments alone can determine.

In a work by the Abbé Bossut and M. Viallet, entitled *Recherches sur la Construction la plus avantageuse des Digues*, the reader will find a general solution of the preceding problem, in which the vertical efforts of the water and the adhesion of the surfaces are considered. This able work, which we have followed in the preceding investigation, contains much practical information on the construction of dykes of every kind; and may be considered as a continuation of the second part of Belidor's *Architecture Hydraulique*.

Enumeration of the forces which act upon the dyke.

67. Let ABC be the section of the dyke, AK the surface of the water, AC the curvature required, AB its posterior side; MN $n m$ a horizontal lamina infinitely small, in the direction of which the dyke has a tendency to break in consequence of the efforts of the water upon AM. If the dyke should break in the direction MN, the superior part AMN will detach itself from the inferior part MNBC, by moving from M towards N; and at the moment when the impulse takes place it will have a small motion of rotation round the point N. We must therefore determine the forces which act upon the lamina MN $n m$, and form an equation expressing their equilibrium round the point N. The forces alluded to are evidently, 1. The horizontal efforts of the water; 2. The vertical efforts of the water; 3. The weight of the part AMN; and, 4. The adhesion of the two surfaces MN, $m n$. Of these four forces the first is the only one which has a tendency to overthrow the portion AMN of the dyke; and its efforts are resisted by the three other forces. In order to find the momenta of these forces with regard to the point N let us suppose

- AP=NM ==s
- PM ==y
- The specific gravity of water ==s
- The specific gravity of the dyke ==σ

Then we shall have,

Momentum of these forces. 1. The momentum of the horizontal forces of the water will be $= \frac{1}{3} s y^2$, by the same reasoning that was employed in art. 57.

Of Specific Gravities.

CHAP. II. Of Specific Gravities.

DEFINITION.

Specific gravity defined.

70. THE absolute weights of different bodies of the same bulk are called their *specific gravities* or *densities*; and one body is said to be *specifically heavier*, or *specifically lighter* than another, when under the same bulk it contains a greater or less quantity of matter. Brass, for example, is said to have eight times the specific gravity of water, because one cubic inch of brass contains eight times the quantity of matter, or is eight times heavier than a cubic inch of water.

PROP. I.

71. Fluids pressing against each other into two or more communicating vessels, will be in equilibrium when the perpendicular altitudes above the level of their junction are in the inverse ratio of their specific gravities.

Plate CCLXV. Fig. 1.

If a quantity of mercury be poured into the vessel FMN, it will be in equilibrium when it rises to the same level AHIB in both tubes. Take away an inch of mercury ACDH, and substitute in its room $13\frac{1}{2}$ inches of water FCDG. Then since mercury is $13\frac{1}{2}$ times heavier than water, $13\frac{1}{2}$ inches of water will have the same absolute weight as one inch of mercury, and the equilibrium will not be disturbed; for the column of water FD will exert the same pressure upon the surface CD of the mercury, as the smaller column of mercury did formerly. The surface of the mercury, therefore, will remain at IB: now, since AB, CE, are horizontal lines, AC will be equal to LK; but FC was made $13\frac{1}{2}$ times AC, therefore $FC = 13\frac{1}{2}$ times IK, that is $FC : IK = 13\frac{1}{2} : 1$, the ratio between the specific gravities of mercury and water.

Construction of the barometer.

72. On this proposition depends the theory of the barometer. Let a quantity of mercury be introduced into the tube FMN, and let the pressure of the atmosphere be removed from the surface IB; the pressure of the air upon the other surface CD will be the same as if the tube PD were continued to the top of the atmosphere, and therefore, instead of the column of water FD we have a column of air equal to the height of the atmosphere acting against the mercury CDMIB; the mercury consequently will rise towards N, so that its height will be to the height of the atmosphere as the specific gravity of air is to the specific gravity of mercury; but as the density of the air diminishes as it recedes from the earth, we must take the specific gravity of the air at a mean height in the atmosphere. It is obvious from the proposition, that the altitude of the column of mercury which balances the column of air must be reckoned from CD the level of their junction; and that, when the specific gravity of the air is diminished, the mercury will fall, and will again rise when it regains its former density.

PROP. II.

Bodies immersed in a fluid are pressed upwards with a force equal to the weight of the quantity of fluid displaced.

73. If any body is immersed in a fluid, or floats on its surface, it is pressed upwards with a force equal to the weight of the quantity of fluid displaced.

Let mH be the section of a body immersed in the vessel AB filled with a fluid. Any portion mn of its upper surface is pressed downwards by the column of fluid $CmnD$ (43.); but the similar portion EF of its lower surface is pressed upwards with a column of fluid equal to $CEFD$, therefore the part EF is pressed upwards with the difference of these forces, that is, with a force equivalent to the column of fluid $mEFn$, for $CEFD - CmnD = mEFn$. In the same way it may be shewn, that the remaining part FH is pressed upwards with a force equal to the weight of a column $nFH0$; and therefore it follows, that the rectangle $mEH0$ is pressed upwards with a force equivalent to a column $mEH0$, that is, to the quantity of fluid displaced.

Of Specific Gravities. Demonstration when a parallelepiped is immersed in the fluid. Fig. 2.

74. If the body floats in the fluid like CH in the vessel AB (fig. 3.) the same consequence will follow; for the body CH is evidently pressed upwards with a force equivalent to the column $mEH0$, that is, to the part immersed or the quantity of fluid displaced. Now as the same may be demonstrated of every other section of a solid parallelepiped, we may conclude, that the proportion is true with respect to every solid whose section is rectangular.

When the parallelepiped floats in the fluid. Fig. 3.

75. When the solid has any other form as CD , however irregular, we may conceive its section to be divided into a number of very small rectangles no : then (41.) the small portion of the solid at n is pressed downwards by a column of particles mn , and the small portion at o is pressed upwards by a column of particles equal to no ; therefore the differences of these forces, viz. the column no , is the force with which the portion o is pressed upward. In the same manner it can be shewn, that every other similar portion of the lower surface of the solid CD is pressed upwards with a force equal to a column of particles whose height is equal to the vertical breadth of the solid; but all these columns of particles must occupy the same space as the solid itself, therefore any solid body immersed in a fluid, or floating on its surface, is pressed upwards with a force equal to the weight of the quantity of fluid displaced.

When the solid has any other form. Fig. 4.

76. COR. 1. When a body floats in a fluid, the weight of the quantity of fluid displaced is equal to the weight of the floating solid. For since the solid is in equilibrium with the fluid, the force which causes it to descend must be equal to the force which presses it upward; but the force which keeps a part of the solid immersed in the fluid is the weight of the solid, and the force which presses the solid upward, and prevents it from sinking, is equivalent to the weight of the quantity of fluid displaced (73.); therefore these forces and the weights to which they are equivalent must be equal.

The weight of a floating body is equal to the weight of the quantity of fluid displaced.

77. COR. 2. A solid weighed in a fluid loses as much of its weight as is equal to the weight of the quantity of fluid displaced; for since the body is pressed upwards with a force equal to the weight of the fluid displaced (3.), this pressure acts in direct opposition to the natural gravity or absolute weight of the solid, and therefore diminishes its absolute weight by a quantity equal to the weight of the fluid displaced. The part of the weight thus lost is not destroyed: It is only sustained by a force acting in a contrary direction.

78. COR. 3. A solid immersed in a fluid will sink, if its specific gravity exceed that of the fluid: It will float

Of Specific Gravities float on the surface, partly immersed, if its specific gravity be less than that of the fluid; and it will remain wholly immersed wherever it is placed, if the specific gravities of the solid and fluid are equal. In the first case, the force with which the solid is pressed downwardly exceeds the upward pressure, and therefore it must sink. In the second case, the upward pressure exceeds the pressure downwards, and therefore the body must float; and, in the third case, the upward and downward pressures being equal, the solid will remain wherever it is placed.

79. COR. 4. The specific gravities of two or more fluids are to one another as the losses of weight sustained by the same solid body, and specifically heavier than the fluids, when weighed in each fluid respectively. The solid in this case displaces equal quantities of each fluid; but the losses of weight are respectively as the absolute weights of the quantities displaced (Cor. 2.), therefore the specific gravities, which are as the absolute weights of equal quantities of any body (70), must be as the losses of weight sustained by the immersed solid.

80. COR. 5. The specific gravity of a solid is to that of a fluid as the absolute weight of the solid is to the loss of weight which it sustains when weighed in the fluid. For since the loss of weight sustained by the solid is equal to the absolute weight of the quantity of fluid displaced, or of a quantity of fluid of the same bulk as the solid, the specific gravities, which (70.) are in the ratio of the absolute weights of equal volumes, must be as the absolute weight of the solid to the loss of weight which it sustains.

81. COR. 6. The specific gravity of a solid floating in a fluid, is to the specific gravity of the fluid itself, as the bulk of the part immersed is to the total bulk of the solid.

82. COR. 7. Bodies which sustain equal losses of weight are of the same bulk. For, since the losses of weight are as the weights of the quantities of fluid displaced, and as the quantities displaced are as the bulks of the solids which displace them, the bulks must be equal when the losses of weight are equal.

83. The preceding corollaries may be expressed algebraically, and may be deduced from a general equation in the following manner. Let B be the total bulk of a floating body, and C the part of it which is immersed; let S be the specific gravity of the solid, and s that of the fluid. Then it is obvious, that the absolute weight of the solid will be expressed by $B \times S$, and the absolute weight of the fluid displaced by $C \times s$; for the fluid displaced has the same bulk as the part of the solid which is immersed. In order that an equilibrium may obtain between the solid and fluid, we must have $B \times S = C \times s$: Now, when $s > S$, we have $B > C$, so that the solid will float, which is the second case of Cor. 3.—When $S = s$ we have $B = C$, which is the third case of Cor. 3.—When $S > s$ we have $C > B$, that is, the body will sink below the surface; and it will descend to the bottom, for it cannot be suspended in the fluid without some power to support it; and if such a power were necessary, we should have $B \times S > C \times s$, which is contrary to the equation of equilibrium.

84. From the equation $B \times S = C \times s$ we have (Euclid VI. 16.) $S : s = B : C$, which is Cor. 6.—When the

body is completely immersed we have $B = C$, in which case the equation becomes $B \times S = B \times s$; and when the solid is specifically heavier than the fluid, it will require a counterweight to keep the solid suspended in the fluid. Let W be the counterweight necessary for keeping the solid suspended in the fluid, then in the case of an equilibrium the equation will be $B \times s + W = B \times S$, or $B \times S - W = B \times s$, or $S \times B - W = S \times B \times s$, whence (Euclid VI. 16.) $S : s = B \times S : B \times S - W$, which is Cor. 5.

85. If the same solid body is plunged in a second fluid of a different specific gravity from the first let σ be the specific gravity of the second fluid, and w the counterweight necessary to keep the solid suspended in it. The equation for the first fluid was $B \times s + W = B \times S$ (84.), and the equation for the second fluid will be $B \times \sigma + w = B \times S$; therefore we shall have, by the first equation $S \times B - W = s \times B$, and by the second $S \times B - w = \sigma \times B$, and consequently $s \times B : \sigma \times B = S \times B - W : S \times B - w$, or (Euclid V. 16.) $s : \sigma = S \times B - W : S \times B - w$, which is Cor. 4.; for the losses of weight in each fluid are evidently represented by $S \times B - W$ and $S \times B - w$.

86. If B and b express the bulks of two solids, S and s their specific gravities, σ the specific gravity of the fluid, and W, w the counterweights which keep them in equilibrium with the fluid. Then with the solid S the equation will be $S \times B - W = \sigma \times B$ (85.); and with the solid s the equation will be $s \times b - w = \sigma \times b$. Wherefore, if the two solids sustain equal losses of weight, we shall have $S \times B - W = s \times b - w$, since each side of the equation represents the loss of weight sustained by each solid respectively. Consequently, $\sigma \times B = \sigma \times b$, and dividing by σ , we have $B = b$, which is corollary 7.

87. From the preceding proposition and its corollaries, we may deduce a method of detecting adulteration in the precious metals, and of resolving the problem proposed to Archimedes, by Hiero king of Syracuse. Take a real guinea, and a counterfeit one made of copper and gold. If the latter be lighter than the former, when weighed in a pair of scales, the imposition is instantly detected: But should their weight be the same, let the two coins be weighed in water, and let the loss of weight sustained by each be carefully observed, it will then be found that the counterfeit will lose more of its weight than the unadulterated coin. For, since the specific gravity of copper exceeds that of gold, and since the absolute weights of the coins were equal, the counterfeit guinea must be greater in bulk than the real one, and will therefore displace a greater quantity of water, that is (77.), it will lose a greater part of its weight.

88. Hiero, king of Syracuse, having employed a goldsmith to make him a crown of gold, suspected, that proposed the metal had been adulterated, and inquired at Archimedes if his suspicions could be verified or disproved without injuring the crown. The particular method by which Archimedes detected the fraud of the goldsmith is not certainly known; but it is probable that he did it in the following manner. A quantity of gold, of the same absolute weight as the crown, would evidently have the same bulk also, if the crown were pure gold, and would have a greater bulk if the crown were

The preceding corollaries deduced from an equation of equilibrium.

Method of detecting adulteration in metals.

by Hiero to Archimedes.

Of Specific Gravities. made of adulterated gold. By weighing, therefore, the quantity of gold and the crown in water, and observing their respective losses of weight, Archimedes found that the crown lost more of its weight than the quantity of gold; and therefore concluded, that as the crown must have displaced a greater portion of water than the piece of gold, its bulk must likewise have been greater, and the metal adulterated of which it was composed.

miscible fluids, and therefore its specific gravity should be ascertained by the present proposition. **Of Specific Gravities.**

PROP. III.

89. If two immiscible fluids, of different specific gravities, and a solid of an intermediate specific gravity, be put into a vessel, the part of the solid in the lighter fluid will be to the whole solid, as the difference between the specific gravities of the solid and the heavier fluid, is to the difference between the specific gravities of the two fluids.

PROP. IV.

92. If two bodies, whether solid or fluid, be mixed together so as to form a compound substance, the bulk of the heavier is to the bulk of the lighter ingredient, as the difference between the specific gravities of the compound, and the lighter ingredient, is to the difference between the specific gravities of the compound and the heavier ingredient.

Fig. 5.

Let AB (fig. 5.) be the vessel which contains the two fluids, suppose mercury and water, and the solid CD. The mercury being heavier than water will sink to the bottom and have mn for its surface, and the water will occupy the space AB mn. The solid having a greater specific gravity than water, will sink in the water (78.); but having a less specific gravity than mercury, it will float in the mercury. It will, therefore, be suspended in the fluids, having one portion C in the water, and the other portion D in the mercury. Now let S be the specific gravity of the mercury, s the specific gravity of the water, σ that of the solid, C the part of the solid in the water, and D the part of the mercury. Then the bulk of the solid is C + D, and its weight σ × C + D: The quantity of water displaced by the part C, or the loss of weight sustained by the part C, will be C × s; and the quantity of mercury displaced, or the loss of weight sustained by part D, will be D × S. But as the solid is suspended in the fluids, and therefore in equilibrio with them, the whole of its weight is lost. Consequently, the part of its weight which is lost in the water, added to the part lost in the mercury, must be equal to its whole weight, that is, C × s + D × S = σ × C + D, or s C + SD = σ C + σ D. Transposing σ C and SD, we have s C - σ C = SD - σ D, or C × s - σ = D × S - σ, and (Euclid VI. 16.) C : D = S - σ : s - σ. Then, by inversion and composition (Euclid V. Propositions B and 18.) C : C + D = S - σ : S - s. Q. E. D.

Let S and s be the specific gravities of the two ingredients, σ the specific gravity of the compound, and B, b the bulks of the ingredients; then the bulk of the compound will be B + b, and its weight σ × B + b. The weight of the ingredient B will be B × S, and that of the other ingredient b × s; and as the weight of the compound must be equal to the weight of its ingredients, we have the following equation. σ b + σ B = BS + b s, and by transposing σ b and BS, we shall have B σ - BS = b s - b σ, or B × σ - S = b × s - σ; therefore (Euclid VI. 16.) B : b = s - σ : σ - S. Q. E. D.

93. In the preceding proposition, it has been taken for granted that the magnitude of the compound is exactly equal to the sum of the magnitudes of the two ingredients. This, however, does not obtain universally either in fluids or solids; for an increase or diminution of bulk often attends the combination of different ingredients. A cubical inch of alcohol, for example, combined with a cubical inch of water, will form a compound which will measure less than two cubical inches; and a cubical inch of tin, when incorporated in a fluid state with a cubical inch of lead, will form a compound, whose bulk will exceed two cubical inches. The preceding proposition, however, is, even in these cases, of great use in ascertaining the increase or decrease of bulk sustained by the compound, by comparing the computed with the observed bulk. See *Specific Gravity*.

PROP. V. PROBLEM.

94. How to determine the specific gravities of bodies whether solid or fluid.

90. COR. 1. From the analogy C : D = S - σ : s - σ, we learn that the part of the solid in the heavier fluid, is to the part in the lighter fluid, as the difference between the specific gravities of the solid and the lighter fluid, is to the difference between the specific gravities of the solid and the heavier fluid.

The simplest and most natural way of finding the specific gravities of bodies would be to take the absolute weights of a cubic inch, or any other determinate quantity, of each substance; and the number thus found would be their specific gravities. But as it is difficult to form two bodies of the very same size, and often impossible, as in the case of precious stones, to give a determinate form to the substance under examination, we are obliged to weigh them in a fluid, and deduce their specific gravities from the losses of weight which they severally sustain. Water is a fluid which is always employed for this purpose, not only because it can be had without difficulty, but because it can be procured of the same temperature, and of the same density, in every part of the world. The specific gravity of water is always called 1.000, and with this, as a standard, the specific gravity of every other substance is compared. Thus, if

91. COR. 2. When s is very small compared with S, we may use the analogy C : C + D = σ : s, though in cases where great accuracy is necessary this ought not to be done. When the specific gravity of a body, lighter than water, is determined by comparing the part immersed with the whole body, there is evidently a small error in the result; for the body is suspended partly in water and partly in air. It is in fact a solid of an intermediate specific gravity floating in two im-

Of Specific Gravities. a certain quantity of water weighed four pounds, and a similar quantity of mercury 56 pounds. the specific gravity of the mercury would be called 14, because as $4 : 56 = 1 : 14$. In order, therefore, to determine the densities of bodies, we have occasion for no other instrument than a common balance with a hook fixed beneath one of its scales. When fitted up in this way, it has been called the *hydrostatic balance*, which has already been described under the article BALANCE, *Hydrostatical*.

Hydrostatic balance.

To find the specific gravity of a solid heavier than water.

95. *When the substance is heavier than its bulk of water.*—Suspend the solid by means of a fine silver wire to the hook beneath the scale, and find its weight in air. Fill a jar with pure distilled water, of the temperature of 62° of Fahrenheit's thermometer, and find the weight of the solid when immersed in this fluid. The difference of these weights is the loss of weight sustained by the solid. Then, (80.) as the loss of weight is to the weight of the solid in air, so is 1.000 the specific gravity of water to a fourth proportional, which will be the specific gravity of the solid. But as the third term of the preceding analogy is always 1.000, the fourth proportional, or density of the solid, will always be had by dividing the weight of the solid in air by its loss of weight in water. If the solid substance consists of grains of platina or metallic filings, place it in a small glass bucket. Find the weight of the bucket in air, when empty, and also its weight when it contains the substance. The difference of these weights will be the weight of the substance in air. Do the very same in water, and its weight in water will be had. Its specific gravity will then be found as formerly.—If the body is soluble in water, or so porous as to absorb it, it should be covered with varnish or some unctuous substance. When it is weighed in water, it should never touch the sides of the glass jar, and it must be carefully freed from any bubbles of air that happen to adhere to it.

To find the specific gravity of a solid lighter than water.

96. *When the substance is lighter than its bulk of water.*—Fasten to it another solid heavier than water, so that they may sink together. Find the weight of the denser body, and also of the compound body, both in air and in water; and by subtracting their weight in water from their weight in air, find how much weight they have severally lost. Then say as the difference between their losses of weight is to the weight of the light body in air, so is 1.000 to the specific gravity of the body.

To find the specific gravity of powders.

97. *When the substance is a powder which absorbs water, or is soluble in it.*—Place a glass phial in one scale, and counterpoise it by weights in the other. Fill this phial with the powder to be examined; and having rammed it as close as possible to the very top, find the weight of the powder. Remove the powder from the phial, and fill it with distilled water, and find its weight. The weight of the powder, divided by the weight of the water, will be the specific gravity of the former.

To find the specific gravity of fluids.

98. *When the substance is a fluid,* its specific gravity may be determined very accurately by the method in the preceding article, or by the following method deduced from article 79.—Take any solid specifically heavier than water, and the given fluid. Find the loss of weight which it sustains in water, and also in the given fluid. Then, since the specific gravities are as the losses of weight sustained by the same solid, the specific

gravity of the fluid required will be found by dividing the loss of weight sustained by the solid in the given fluid, by the loss of weight which it sustains in water.

SECT. II. On the Hydrometer.

99. In order to determine, with expedition, the strength of spirituous liquors, which are inversely proportional to their specific gravities, an instrument more simple, though less accurate, than the hydrostatic balance, has been generally employed. This instrument is called a *hydrometer*, sometimes an *areometer* and *gravimeter*, and very erroneously a *hygrometer* by some foreign authors. It seems to have been invented by Hypathia, the daughter of Theon Alexandrinus, who flourished about the end of the fourth century; though there is some foundation for the opinion that the invention is due to Archimedes.

100. The hydrometer of Fahrenheit, which is one of the simplest that has been constructed, is represented in fig. 6. and may be formed either of glass or metal. AB is a cylindrical stem, and C, D two hollow balls appended to it. Into the lower ball D is introduced a quantity of mercury, sufficient to make the ball C sink to F, a little below the surface of distilled water. If this apparatus be plunged into a fluid lighter than water, the ball C will sink farther below the surface; and if it be immersed in a heavier fluid, it will rise nearer the surface. In this way we can tell whether one fluid is more or less dense than another. But in order to determine the real specific gravities of the fluids, the hydrometer must either be loaded with different weights, or have a scale AB engraven on its stem. The former of these methods was employed by Fahrenheit. Having placed some small weights on the top A, he marked any point E, to which the instrument sunk in distilled water. By weighing the instrument thus loaded, he found the weight of a quantity of water equal to the part immersed (76.). When the hydrometer was placed in a fluid denser than water, he loaded it with additional weights till it sunk to the same point E. The weight of the hydrometer being again found, gave him the weight of a quantity of the denser fluid equal to the part immersed; but as the part immersed was the same in both cases, the weights of the hydrometer were equal to the absolute weights of equal quantities of the two fluids; and consequently the specific gravities of the water and the other fluid were in the ratio of these weights. When the fluid, whose density is required, has less specific gravity than water, some of the weights are to be removed from the top A till the instrument sinks to E; and the density of the fluid to be determined as before.—Instead of making the weight of the hydrometer variable, it is more simple, though less accurate, to have a scale of equal parts upon the stem AB. In order to graduate this scale, immerse the hydrometer in distilled water, at the temperature of 60° Fahrenheit, so that it may sink to B near the bottom of the stem, which may be easily effected, by diminishing or increasing the quantity of mercury in the ball D. At B place the number 1.000, which shows that every fluid, in which the hydrometer sinks to B, has its specific gravity 1.000, or that of distilled water. The hydrometer is then to be plunged in another fluid less dense than water, suppose oil, whose specific gravity

Of Specific Gravities. it sinks. Every fluid, therefore, in which the hydrometer sinks to A, has its specific gravity .900; and if the scale AB be divided into equal parts, every intermediate degree of specific gravity between .900 and 1.000 will be marked. If the scale AB be divided into four parts in the points E, F, G, the fluid in which the hydrometer sinks to G will have .975 for its specific gravity; the specific gravity of that in which it sinks to F will be .950, and so on with the other points of division. If it is required to extend the range of the instrument, and to make it indicate the densities of fluids specifically lighter than water, we have only to load it in such a manner as to make it sink to the middle of the scale F in distilled water; and by taking two fluids, between whose densities the specific gravity of every other fluid is contained, excepting mercury and metals in a fluid state, to determine, as before, the extremities of the scale.

Theorem for hydrometers in which the weight is variable.
Fig. 6.

101. When the weight of the hydrometer is variable, let E be the point to which it sinks in two different fluids; and let W be the absolute weight necessary to make it sink to E in the denser fluid, and $W \pm p$ the weight necessary to make it sink to the same point in the lighter fluid. Let S, s be the specific gravities of the two fluids, and V the volume of the part of the hydrometer that is constantly immersed. Then (83.)

$$W = S \times V, W \pm p = s \times V. \text{ From the first equation we have, } V = \frac{W}{S}, \text{ and from the second equation } V = \frac{W \pm p}{s}, \text{ consequently } \frac{W \pm p}{s} = \frac{W}{S}, \text{ and by reduction } s = \frac{s \times W \pm p}{W}.$$

Thus, by knowing W and the weight p, and also S the specific gravity of one of the fluids, which will be 1.000 if that fluid be water, we can find s the specific gravity of the other fluid.

Theorem for hydrometers in which the weight is constant.

102. When the weight of the hydrometer is constant, and the density of the fluid indicated by the depth to which it descends, let F, E be the points to which it sinks in two different fluids, whose specific gravities are S, s, W the absolute weight of the hydrometer, V the volume of the part immersed when the hydrometer has sunk to E, and v its volume when sunk to F. Then (83.), we have $W = S \times V$, and $W = s \times v$, consequently $s \times v = S \times V$, and $s = \frac{S \times V}{v}$.

If the absolute weight W, therefore, of the hydrometer be known, and also the volumes V, v, and the specific gravity S of one of the fluids, which may be water, the specific gravity of the other fluid may be determined by the preceding formula. When the figure of the hydrometer is regular, the volumes V, v, may be determined geometrically; but as the instrument is generally of an irregular form, the following method should be employed.

Description of various hydrometers.

Jones's hydrometer.

103. The hydrometers of Clarke and Desaguliers differ so little from those which have now been described, that they are not entitled to a more particular description. The hydrometer invented by Mr William Jones of Holborn, is a simple and accurate instrument, and requires only three weights to discover the strengths of spirituous liquors from alcohol to water. Like other instruments of the same kind, it is adjusted to the temperature of 60° of Fahrenheit; but as every change of

temperature produces a change in the specific gravity of the spirits, Mr Jones found it necessary to attach a thermometer to the instrument, and thus make a proper allowance for every variation of temperature. Almost all bodies expand with heat and contract with cold; and as their volume becomes different at different temperatures, their specific gravities must also (70.) be variable, and will diminish with an increase of temperature. M. Homborg, and M. Eisenched found that the absolute weight of a cubic inch of brandy was four drams 42 grains in winter, and only four drams 32 grains in summer, and that the difference in spirits of nitre was still greater. It has been found, indeed, upon an average, that 32 gallons of spirits in winter will expand to 33 gallons in summer. As the strength of spirituous liquors is inversely as their specific gravities, they will appear much stronger in summer than in winter. This change in their strength had been formerly estimated in a rough way; but by the application of the thermometer, and by adjusting its divisions experimentally, Mr Jones has reduced it to pretty accurate computation. It has already been stated (93.) that where two substances are combined, the magnitude of the compound body is sometimes greater and sometimes less than the sum of the magnitudes of the two ingredients, and that this mutual penetration particularly happened in the mixture of alcohol and water. In strong spirits, this concentration is sometimes so great, as to produce a diminution of four gallons in the 100; for if to 100 gallons of spirit of wine found by the hydrometer to be 66 gallons in the 100 over proof, you add 66 gallons of water to reduce it to proof, the mixture will consist only of 162 gallons instead of 166 of proof spirits. This mutual penetration of the particles of alcohol and water has also been considered in Mr Jones's hydrometer, which we shall now describe with greater minuteness.

Plate GCLXV. 45-7.

104. In fig. 7. the whole instrument is represented with the thermometer attached to it. Its length AB is about 9½ inches: the ball C is made of hard brass, and nearly oval, having its conjugate diameter about 1¼ inches. The stem AD is a parallelepiped, on the four sides of which the different strengths of spirits are engraved: the three sides which do not appear in fig. 7. are represented in fig. 8. with the three weights numbered 1, 2, 3, corresponding with the sides similarly marked at the top. If the instrument when placed in the spirits sinks to the divisions on the stem without a weight, their strength will be shown on the side AD marked o at the top, and any degree of strength from 74 gallons in the 100 to 47 in the 100 above proof, will thus be indicated. If the hydrometer does not sink to the divisions without a weight, it must be loaded with any of the weights 1, 2, 3, till the ball C is completely immersed. If the weight N° 1 is necessary, the side marked 1 will show the strength of the spirits, from 46 to 13 gallons in the 100 above proof. If the weight N° 2 is employed, the corresponding side will indicate the remainder of overproof to proof, marked P in the instrument, and likewise every gallon in 100 under proof, down to 29. When the weight N° 3 is used, the side similarly marked will show any strength from 30 gallons in the 100 under proof, down to water; which is marked W in the scale. The small figures as 4 at 66, 3½ at 61, 2½ at 48 (fig. 7.) indicate the diminution

Of Specific Gravities. of bulk which takes place when water is mixed with spirits of wine in order to reduce it to proof: thus, if the spirit be 61 gallons in the 100 over proof, and if 61 gallons of water are added in order to render it proof, the magnitude of the mixture will be $3\frac{1}{2}$ gallons less than the sum of the magnitudes of the ingredients, that is, instead of being 161 it will be only 157 $\frac{1}{2}$ gallons. The thermometer F connected with the hydrometer, has four columns engraved upon it, two on one side as seen in the figure, and two on the other side. When any of the scales upon the hydrometer, marked 0, 1, 2, 3, are employed, the column of the thermometer similarly marked must be used, and the number at which the mercury stands carefully observed. The divisions commence at the middle of each column which is marked 0, and is equivalent to a temperature of 60 degrees of Fahrenheit; then, whatever number of divisions the mercury stands above the zero of the scale, the same number of gallons in the 100 must the spirit be reckoned weaker than the hydrometer indicates, and whatever number of divisions the mercury stands below the zero, so many gallons in the 180 must the spirit be reckoned stronger.

Dicas's hydrometer with a sliding rule. 105. The patent hydrometer invented by Mr Dicas of Liverpool, possesses all the advantages of that which has now been described, but is superior to it in regard to the accuracy with which it estimates the aberration arising from a change of temperature. It is constructed in the common form, with 36 different weights, which are valued from 0 to 370, including the divisions on the stem; but the chief improvement consists in an ivory sliding rule which accompanies the instrument. In order to understand the construction of this sliding rule the reader must have recourse to the instrument itself.

Quin's universal hydrometer. 106. Quin's universal hydrometer is constructed in such a manner, as to ascertain, with the greatest expedition, the strength of any spirit from alcohol to water, and also the concentration and specific gravity of each different strength. With the assistance of four weights, it discovers likewise the gravity of worts, and is therefore of more universal use than any other hydrometer. The instrument is represented in fig. 9. with the four sides of its stem graduated and marked at the top so as to correspond with the weights below. The side of the stem marked A, B, C, D, &c. to Z, shows the strength of any spirit from alcohol to water, and the three other sides numbered 1, 2, 3, are adapted for worts. The variation of density arising from the contraction and dilatation of the fluid is determined by means of a sliding rule, differing very little from that of Mr Dicas. In order to use this instrument, place any of the weights, if necessary, on the stem at C; find the temperature of the spirit by a thermometer, and bring the star on the sliding rule to the degree of heat on the thermometer's scale: then opposite to the number of the weight and the letter on the stem, you have the strength of the spirit pointed out on the sliding rule, which is lettered and numbered in the same way as the instrument and weights. In ascertaining the strength of worts, the weight N^o 4 is always to continue on the hydrometer, and the weights, N^o 1, 2, 3, are adapted to the sides N^o 1, 2, 3, of the square stem, which point out the exact gravity of the worts.

Nicholson's hydrometer.

107. A considerable improvement on the hydrometer

has lately been made by Mr Nicholson, who has rendered it capable of ascertaining the specific gravities both of solids and fluids. In fig. 10. F is a hollow ball of copper attached to the dish AA by a stem B, made of hardened steel. To the lower extremity of the ball is affixed a kind of iron stirrup FF, carrying another dish G of such a weight as to keep the stem vertical when the instrument is afloat. The parts of the hydrometer are so adjusted, that when the lower dish G is empty, and the upper dish AA contains 1000 grains, it will sink in distilled water at the temperature of 60° of Fahrenheit, so that the surface of the fluid may cut the stem DB at the point D. In order to measure the specific gravities of fluids, let the weight of the instrument, when loaded, be accurately ascertained. Then, this weight is equal to that of a quantity of distilled water at the temperature of 60°, having the same volume as that part of the instrument which is below the point D of the stem. If the hydrometer, therefore, is immersed to the point D in any other fluid of the same temperature, which may be done by increasing or diminishing the weights in the dish AA, the difference between this last weight and 1000 grains will express the difference between equal bulks of water and the other fluid. Now as the weight of the mass of water is equal to the weight of the instrument, which may be called W, the above-mentioned difference or D must be either added to or subtracted from W, (according as the weight in the dish AA was increased or diminished) in order to have the weight of an equal bulk of the fluid; then $W \pm D$ will be to W as the specific gravity of the given fluid is to that of water. This ratio will be expressed with considerable accuracy, as the cylindrical stem of the instrument being no more than $\frac{1}{16}$ th of an inch in diameter, will be elevated or depressed nearly an inch by the subtraction or addition of $\frac{1}{16}$ of a grain, and will, therefore, easily point out any changes of weight, not less than $\frac{1}{16}$ of a grain, or $\frac{1}{16000}$ of the whole, which will give the specific gravities to five places of figures. The solid bodies whose specific gravities are to be determined by this hydrometer, must not exceed 1000 grains in weight. For this purpose, immerse the instrument in distilled water, and load the upper dish till the surface of the water is on a level with the point D of the stem. Then, if the weight required to produce this equilibrium be exactly 1000 grains, the temperature of the water will be 60° of Fahrenheit; but if they be greater or less than 1000 grains, the water will be colder or warmer. After noting down the weight necessary for producing an equilibrium, unload the upper dish, and place on it the body whose specific gravity is required. Increase the weight in the upper dish, till the instrument sinks to the point D, and the difference between this new weight and the weight formerly noted down will be the weight of the body in air. Place the body in the lower dish G, and add weights in the upper dish till the hydrometer again sinks to D. This weight will be the difference between 1000 grains and the weight of the body in water; and since the weight of the body in air, and its weight in water, are ascertained, its loss of weight will be known, and consequently its specific gravity (80.).

108. The areometer or hydrometer of M. de Parcieux consists of a small glass phial EG, about two inches in diameter

De Parcieux's areometer. Plate CCLXVI. fig. 6.

Of Specific Gravities.
 Plate CCLXXVI.
 Fig. 1.

diameter and seven inches long, having its bottom as flat as possible. The mouth is closed with a cork stopper, into which is inserted a straight iron or brass wire EF, about a line in diameter, and 30 inches long. When two fluids are to be compared, the bottle is loaded in such a manner by the introduction of small shot, that the instrument, when plunged in the lightest of the fluids, sinks so deep as to leave only the extremity of the wire above its surface, while in the heaviest fluid, the wire is some inches below the surface. The same effect may be produced by fixing a little dish F to the top of the wire, and varying the weights, or by altering the thickness of the wire. The areometer thus constructed, will indicate the smallest differences of specific gravity, and such minute variations of density, arising from a change of temperature, which would be imperceptible by any other hydrometer. The motion of an instrument of this kind, says Montucla, was so sensible, that when immersed in water of the usual temperature, it sunk several inches while the rays of the sun fell upon the water, and instantly rose when his rays were intercepted. In one of the areometers used by Deparcieux, an interval of six lines in the stem corresponded to a change of density about $\frac{1}{135000}$ of the whole. (*Mém. de l'Acad. Paris* 1766, p. 158.)

Wilson's hydrometer.

109. In order to determine the strength of spirits with the greatest expedition, Professor Wilson of Glasgow employed a very simple method. His hydrometer consists of a number of glass beads, the specific gravities of each of which vary in a known ratio. When the strength of any spirit is to be tried, the glass beads,

which are all numbered, are to be thrown into it. Some of those whose specific gravity exceeds that of the spirit, will sink to the bottom, while others will swim on the top, or remain suspended in the fluid. That which neither sinks to the bottom nor swims on the surface, will indicate by its number the specific gravity of the spirits (78.). For an account of the Patent Beads constructed by Mrs Lovi of Edinburgh, in all respects the most accurate apparatus for this purpose, see note under *SPIRITUOUS Liquors*.

SECT. III. On Tables of Specific Gravities.

110. As the knowledge of the specific gravities of bodies is of great use in all the branches of mechanical philosophy, we have given the following table, published in the enlarged edition of Ferguson's Lectures, 2d edition. It comprehends the greater part of Brisson's tables, and is one of the most extensive that has yet been published. The names of the minerals, as given in Kirwan's Mineralogy, have in general been adopted; and such as have been discovered since the publication of that work will be found in later works. When the specific gravities of any substance, as determined by different authors, seem to be at variance, the different results are frequently given, and the names of the chemists prefixed by whom these results were obtained. The substances in the table have, contrary to the usual practice, been disposed in an alphabetical order. This was deemed more convenient for the purposes of reference, than if they had been divided into classes, or arranged according to the order of their densities.

TABLE of Specific Gravities.

A			
ACACIA, inspissated juice of,	1.5153	Agate, stained, veined,	2.6324
Acid, nitric,	1.2715	Icelandic,	2.6667
muriatic,	1.1940	of Havre,	2.348
red acetous,	1.0251	Jaspée,	2.5881
white acetous,	1.0135	Herborisée,	2.6356
distilled acetous,	1.0095	Irisée,	2.5891
acetic,	1.0626	Air, atmospheric,	2.5535
sulphuric,	1.8409	Barom. 29.75 } Thermom. 32. } Barom. 29.85 } Thermom. 54°.5 }	0.00122
highly concentrated,	2.125		Lavoisier. 0.0012308
nitric, highly concentrated,	1.580	Alabaster of Valencia,	2.638
fluoric,	1.500	veined,	2.691
formic,	0.9942	of Piedmont,	2.693
phosphoric,	1.5575	of Malta,	2.699
citric,	1.0345	yellow,	2.699
arsenic,	1.8731	Spanish saline,	2.713
of oranges,	1.0176	oriental white,	2.730
of gooseberries,	1.0581	ditto, semitransparent,	2.762
of grapes,	1.0241	stained brown,	2.744
Actynolite, glassy,	Kirwan. { 2.950	of Malaga pink,	2.8761
Æther, sulphuric,	3.903	of Dalias,	2.6110
nitric,	0.7396	Alcohol, highly rectified,	0.8293
muriatic,	0.9088	commercial,	0.7371
asetic,	0.7296	15 parts water 1 part	0.8527
Agate, oriental,	0.8664	14 2	0.8674
onyx,	0.5901	13 3	0.8815
speckled,	2.6375	12 4	0.8947
cloudy,	2.607	11 5	0.9075
	2.6253		Alcohol,

Of Specific Gravities.	Alcohol, 10 parts water 6	0.9199	Asbestos, mountain cork,	<i>Bergman.</i>	{ 0.6806	Of Specific Gravities
	9	0.9317			{ 0.9933	
	8	0.9427		penetrated with	{ 1.2492	
	7	0.9519		water,	{ 1.3492	
	6	0.9594	ripe,	<i>Brisson.</i>	2.5779	
	5	0.9674	penetrated with water,		2.6994	
	4	0.9733	starry,		3.0733	
	3	0.9791	penetrated with water,		3.0808	
	2	0.9852	unripe,		2.9958	
	1	0.9919	penetrated with water,		3.0343	
Alder wood,	<i>Muschenbroek.</i>	0.8000	Ash trunk,	<i>Muschenbroek.</i>	0.8450	
Aloes, hepatic,		1.3586	dry,	<i>Turin.</i>	0.800	
saccharine,		1.3795	Asphaltum, cohesive,		{ 1.450	
Alouchi, odoriferous gum,		1.0604			{ 2.060	
Alumina, sulphate of,	<i>Muschenbroek.</i>	1.7140	compact,		{ 1.070	
saturated solution of,					{ 1.165	
temp. 42°, <i>Watson.</i>		1.033	Asafoetida,		1.3275	
Amber, yellow transparent,		1.0780	Aventurine, semitransparent,		2.6667	
opaque,		1.0855	opaque,		2.6426	
red,		1.0834	Augite, octahedral basaltic,	<i>Häuy.</i>	3.226	
green,		1.0829		<i>Werner.</i>	3.471	
Ambergris,		{ 0.7800		<i>Russ.</i>	3.777	
		{ 0.9263	Azure stone, or lapis lazuli,	<i>Brisson.</i>	2.7675	
Ametyst, common. See Rock crystal.		2.750	oriental,	<i>Kirwan.</i>	2.896	
Amianthus, long,		0.9088	of Siberia,		2.7714	
penetrated with water,		1.5662			2.9454	
short,		2.3134				
penetrated with water,		3.3803				
Asianthite from Raschan,		2.584				
Bayreuth,		2.916				
Ammoniac, liquid,		0.8970				
muriate of,	<i>Muschenbroek.</i>	1.4530				
saturated solution of,						
temp. 42°, <i>Watson.</i>		1.072				
Andalusite, or hard spar,	<i>Häuy.</i>	3.165	Barolite, or witherite,		{ 4.300	
Anise, oriental,		1.0284			{ 4.338	
occidental,		1.0426	Baroselenite, or barytes,		{ 4.400	
Antimony, glass of,		4.9464	white,		{ 4.865	
in a metallic state, fused,		{ 6.624	grey,		4.4308	
native,	<i>Klaproth.</i>	6.860	rhomboidal,		4.4909	
sulphur of		6.720	octahedral,		4.4434	
Antimonial ore, gray and foliated,	<i>Kirwan.</i>	4.0643	in stalactites,		4.4712	
radiated,	<i>Kirwan.</i>	4.368	sulphate of, native,	<i>Kirwan.</i>	{ 4.000	
red,	<i>La Metheric.</i>	3.750	carbonate of, native,		{ 4.460	
	<i>Klaproth.</i>	4.090			{ 4.300	
Apple tree,	<i>Muschenbroek.</i>	0.7930	Basaltic,	<i>Kirwan.</i>	{ 4.338	
Aquamarine. See Beryl.				<i>Bergman.</i>	2.979	
Arcanson,		1.0857			3.000	
Areca, inspissated juice of,		1.4573	from the Giant's causeway,		2.864	
Arctizite, or wernerite,	<i>Dandrada.</i>	3.606	prismatic from Auvergne,		2.4215	
Argillite, or slate clay,	<i>Kirwan.</i>	{ 2.600	of St Tubery,		2.7948	
		{ 2.680	Baras, a juice of the pine,		1.0441	
Arnotto,		0.5956	Bay tree, Spanish,	<i>Muschenbroek.</i>	0.8220	
Arragon spar,	<i>Häuy.</i>	2.946	Bdellium,		1.1377	
Arsenic bloom, Pharmacolite,	<i>Klaproth.</i>	2.640	Beech-wood,	<i>Muschenbroek.</i>	0.8520	
fused,	<i>Bergman.</i>	8.310	Beer, red,		1.0338	
native,	<i>Kirwan.</i>	5.670	white,		1.0231	
pyrites, common,	<i>Stiltz.</i>	4.791	Benzoin,		1.0924	
	<i>La Metheric.</i>	5.600	Beryl, oriental aquamarine,		3.5491	
	<i>Brisson.</i>	6.523	occidental,		2.723	
native, orpiment,		5.452	or aquamarine,	<i>Werner.</i>	{ 2.650	
glass of, (arsenic of the shops),		3.5942	schorlous, or shorlite,	<i>Häuy.</i>	{ 2.759	
Asbestinite,	<i>Kirwan.</i>	{ 3.000	Bezoar, oriental,		3.514	
		{ 3.310	occidental,		1.666	
			occidental,		2.233	
			Bismuth, native,	<i>Kirwan.</i>	9.570	
			sulphurated,	<i>Kirwan.</i>	6.181	
			ochre,	<i>Brisson.</i>	4.371	
			in a metallic state, fused,		{ 9.756	
					{ 9.822	
					Bitumes,	

<i>Specific Gravity.</i>	Bitumen, of Judaea,	1.104	Cedar, wild,	<i>Muschenbroek.</i>	0.5608	<i>Of Specific Gravity.</i>
	Black-coal, pitch coal,	<i>Wiedemann.</i> 1.308	Palestine,	<i>Muschenbroek.</i>	0.5960	
	slate coal, English,	<i>Kirwan.</i> { 1.250	Indian,	<i>Muschenbroek.</i>	1.3150	
	Bielschowitz,	1.370	Celestine,	<i>Klaproth.</i>	3.830	
	cannel coal,	<i>Richter.</i> { 1.321	foliated,		3.500	
		1.382	Ceylanite,	<i>Häuy.</i> { 3.765		
		<i>La Metherie.</i> 1.270		3.793		
	Bleude, yellow,	<i>Gellert.</i> { 4.044	Chalcedony, bluish,		2.5867	
		4.048	onyx,		2.6151	
	brown, foliated,	<i>Gellert.</i> { 3.770	veined,		2.6059	
	black,	4.048	transparent,		2.6640	
		<i>Gellert.</i> 3.930	reddish,		2.6645	
	auriferous from Nag-	<i>Brisson.</i> 4.166	common,	<i>Kirwan.</i> { 2.600		
	yag,	<i>Von Muller.</i> 5.398	Chalk,	<i>Muschenbroek.</i>	2.252	
	Blood, human,	<i>Jurin.</i> 1.054	Cherry-tree,	<i>Watson.</i>	2.657	
	crassamentum of,	<i>Jurin.</i> 1.126	Chrysoberyl,	<i>Muschenbroek.</i>	0.7150	
	serum of,	<i>Jurin.</i> 1.030		<i>Werner.</i> { 3.600		
	Boles,	<i>Kirwan.</i> { 1.400		3.720		
		2.000	Chrysolite of the jewellers,	<i>Häuy.</i>	3.796	
	Bone of an ox,	1.656	of Brasil,	<i>Brisson.</i>	2.782	
	Boracite,	<i>Westrumb.</i> 2.566		2.692		
	Borax,	1.714		<i>Werner.</i> { 3.340		
	saturated solution of,		Chrysoptase,	3.410		
	temp. 42°,	<i>Watson.</i> 1.010		2.489		
	Bourneite,	5.576	Crystal. See Rock.	3.250		
	Boxwood, French,	<i>Muschenbroek.</i> 0.9120	Crystalline lens,		1.100	
	Dutch,	<i>Muschenbroek.</i> 1.3280	Cinnabar, dark red, from Deux			
	dry,	<i>Jurin.</i> 1.030	Ponts,	<i>Kirwan.</i>	7.786	
	Brass, common, cast,	7.824	from Almaden,	<i>Brisson.</i>	6.902	
	wiredrawn,	8.544	crystallized,	<i>Brisson.</i>	10.218	
	cast, not hammered,	8.396	Cinnamon, volatile oil of,		1.044	
	Brazil wood, red,	<i>Muschenbroek.</i> 1.0310	Citron tree,	<i>Muschenbroek.</i>	0.7263	
	Brick,	2.000	Clinkstone,	<i>Klaproth.</i>	2.575	
	Butter,	0.9423	Cloves, volatile oil of,		1.036	
			Cobalt, in a metallic state, fused,		7.645	
			ore, gray,	<i>Häuy.</i> { 7.811		
				5.511		
			ochre, black, indurated,	<i>Kirwan.</i>	5.309	
			vitreous oxide of,	<i>Gellert.</i> { 2.019		
				2.425		
			Cocos wood,	<i>Muschenbroek.</i>	2.4405	
			Coccolite,	<i>Dandrada.</i>	1.0403	
			Columbium,	<i>Hatchet.</i>	3.316	
			Copal, opaque,		5.918	
			transparent,		1.1398	
			Madagascar,		1.0452	
			Chinese,		1.0600	
					1.0628	
			Copper, native,	<i>Kirwan.</i> { 7.600		
			from Siberia,	<i>Häuy.</i>	7.800	
			Hungary,	<i>Gellert.</i>	8.5084	
			ore, compact vitreous,	<i>Kirwan.</i>	7.728	
			Cornish,	<i>Kirwan.</i>	4.129	
			purple, from Bannat,	<i>Kirwan.</i>	5.452	
			from Lorraine,	<i>La Metherie.</i>	4.956	
				<i>Kirwan.</i>	4.300	
				<i>Wiedemann.</i>	4.983	
				<i>Kirwan.</i>	5.467	
			pyrites,	<i>Kirwan.</i>	4.080	
				<i>Brisson.</i>	4.344	
			ore, white,	<i>La Metherie.</i>	4.500	
			gray,	<i>Häuy.</i>	4.865	

Of Specific Gravities.	Of Specific Gravities.
Glance-coal, slaty,	1.300
Glass, white flint,	1.530
crown,	3.00
common plate,	2.520
yellow plate,	2.760
white, or French crystal,	2.520
St Gobins,	2.8922
gall,	2.4882
bottle,	2.8548
Leith crystal,	2.7325
green,	3.189
borax,	2.6423
fluid,	2.6070
of Bohemia,	3.329
of Cherbourg,	2.3959
of St Cloud,	2.5596
animal,	3.2549
mineral,	2.5647
Gold, pure, of 24 carats fine, fused, but not hammered,	2.2694
the same hammered,	19.258
English standard, 22 carats fine, fused, but not hammered,	19.342
guinea of George II.	18.888
guinea of George III.	17.150
Parisian standard, 22 carats, not hammered,	17.629
the same hammered,	17.486
Spanish gold coin,	17.589
Holland ducats,	17.655
trinket standard, 20 carats, not hammered,	19.352
the same hammered,	15.709
Portuguese coin,	15.775
French money, 21½ carats, fused, coined,	17.9664
French in the reign of Louis XIII.	17.4022
Granite, red Egyptian,	7.6474
gray, Egyptian,	17.5531
beautiful red,	2.6541
of Girardmor,	2.7279
violet of Gyromagny,	2.7609
red of Dauphiny,	2.7163
green, ———	2.6852
radiated, ———	2.6431
red of Semur,	2.6836
gray of Bretagne,	2.6678
yellowish,	2.6384
of Carinthia, blue,	2.7378
Granitelle, of Dauphiny,	2.6136
Graphic ore,	<i>Kirwan.</i> 2.9564
Graphite. See Plumbago.	3.0626
Grenatite. See Staurotide.	2.8465
Gum Arabic,	<i>Muller.</i> 5.723
tragacanth,	1.4523
seraphic,	1.3161
cherry tree,	1.201
Bassora,	1.4817
Acajou,	1.4346
Moubain,	1.4456
Gutte,	1.4206
ammoniac,	1.2216
Gayac,	1.2071
1.2289	1.2289
Gum lac,	1.1390
animé d'orient,	1.0284
d'occident,	1.0426
Gunpowder in a loose heap,	0.836
shaken,	0.932
solid,	1.745
Gypsum, opaque,	2.1679
compact, specimen in the Leskean collection,	2.939
compact,	1.872
impure,	2.288
foliated, mixed with granular limestone,	2.473
alabaster,	<i>Kirwan.</i> 2.725
semitransparent,	<i>Ward.</i> 1.872
fine ditto,	2.3062
opaque,	2.2741
rhomboidal,	2.2642
ditto, 10 faces,	2.3114
cuniform, crystallised,	2.3117
striated of France,	2.3060
of China,	2.3057
flowered,	2.3088
spathic opaque,	2.3059
semitransparent,	2.2746
granularly foliated, in the Leskean collection,	3.3108
mixed with marl, of a slaty form,	<i>Kirwan.</i> 2.900
	2.473
	H
Hazel,	<i>Muschenbroek.</i> 0.606
Heavy spar, fresh, straight, lamellar,	4.300
columned, ——— not above	4.500
Heliotropium,	4.500
	<i>Kirwan.</i> 2.629
	2.700
	<i>Blumenbach.</i> 2.633
Hematites. See Ironstone.	
Hollow spar, Chialtolite,	2.944
Hone, razor, white,	2.8763
penetrated with water,	2.8839
razor, white and black,	3.1271
Honey,	1.4500
Honestone, or Mellilite,	1.586
	1.666
Hornblende, common,	3.600
	<i>Kirwan.</i> 3.830
resplendent, Labrador,	<i>Kirwan.</i> 3.350
Schiller spar,	<i>Kirwan.</i> 3.434
schistose,	2.882
basaltic,	2.909
	3.155
	<i>Reuss.</i> 3.150
	3.220
	<i>Kirwan.</i> 3.333
Hornstone, or Petrosilex,	2.530
ferruginous,	2.653
veined,	2.813
Hornstone, gray. See <i>Kirwan's Mineralogy</i> ,	2.747
blackish gray,	2.654
yellowish white,	2.744
bluish, and partly yellowish gray,	2.563
dark purplish red iron shot,	2.626
	2.638

		Of Specific Gravities.		
Lead glance, compact,	<i>Gellert.</i>	6.886	<i>Brisson.</i> { 4.249 <i>Rinmann.</i> { 4.756 <i>Hagen.</i> 4.181 <i>Kirwan.</i> 3.742 <i>Dalomicu.</i> { 3.233 { 2.0000 <i>Brisson.</i> { 3.0000 { 3.7076 { 3.9039 { 4.1165 <i>Muschenbroek.</i> 0.7550 2.726 2.695 2.650 2.700 2.710 2.705 2.678 2.755 2.708 2.858 2.728 2.728 2.649 2.714 2.668 2.516 1.0742 <i>Muschenbroek.</i> 0.8490 <i>Muschenbroek.</i> 0.9440 <i>Karsten.</i> 3.691 <i>Werner.</i> 3.800 <i>Lampadius.</i> 4.270 <i>Gregor.</i> 4.427 <i>Kirwan.</i> { 7.186 { 7.352 <i>Gellert.</i> 7.937 13.619 13.580 13.375 <i>Biddle.</i> 15.612 <i>Biddle.</i> 13.545 <i>Watson.</i> 1.037 9.230 10.871 8.399 <i>Hahn.</i> 2.233 <i>Brisson.</i> 2.791 <i>Blumenbach.</i> 2.934 1.0203 1.0346 1.0355 1.0341 1.0409 1.0324 <i>Gregor.</i> 2.253 Mineral	
	crystallized,	<i>Kirwan.</i>		4.319
	radiated,	<i>Brisson.</i>		7.587
	from the Hantz,	<i>La Metherie.</i>		5.500
	Kautenbach,	<i>Kirwan.</i>		7.448
	Kirschwalder,	<i>Vauquelin.</i>		6.140
	ore, corneous,	<i>Vauquelin.</i>		6.820
	reniform,	<i>Cheneviz.</i>		6.065
	of black lead,	<i>Bindheim.</i>		3.920
	blue,	<i>Gellert.</i>		6.745
	brown,	<i>Wiedemann.</i>		5.461
	from Huguelgoet,	<i>Klaproth.</i>		6.974
	black,	<i>Häuy.</i>		6.600
	white from Leadbills,	<i>Gellert.</i>		6.909
	phosphorated from Wanlock-	<i>Cheneviz.</i>		5.770
head,	<i>Häuy.</i>	7.236		
Zschoppan,	<i>Häuy.</i>	6.559		
Briegaw,	<i>Klaproth.</i>	6.560		
red; or red lead spar,	<i>Klaproth.</i>	6.270		
yellow, molybdenated,	<i>Häuy.</i>	6.941		
Lead,	<i>Bindheim.</i>	5.750		
acetite of,	<i>Brisson.</i>	6.027		
vitriol from Anglesea,	<i>Brisson.</i>	5.092		
Lemon tree,	<i>Gellert.</i>	11.352		
Lenticular ore (arsenate of copper),	<i>Muschenbroek.</i>	11.445		
Lepidolite, lilalite,	<i>Klaproth.</i>	2.3953		
	<i>Klaproth.</i>	6.300		
	<i>Muschenbroek.</i>	0.7033		
	<i>Bournon.</i>	2.882		
	<i>Klaproth.</i>	2.816		
	<i>Häuy.</i>	2.854		
	<i>Klaproth.</i>	2.455		
	<i>Klaproth.</i>	2.490		
	<i>Muschenbroek.</i>	1.3330		
		1.3864		
		2.7200		
		2.710		
		2.837		
		2.700		
		2.800		
		3.182		
		2.742		
		3.156		
		2.700		
	<i>Muschenbroek.</i>	0.604		
	<i>Muschenbroek.</i>	0.9130		
M				
Madder root,	<i>Muschenbroek.</i>	0.7650		
Mahogany,		1.0630		
Magnesia,	<i>Kirwan.</i>	2.3300		
sulphate of, saturated solution,	<i>Watson.</i>	1.232		
temp. 42°	<i>Hatchet.</i>	4.518		
Magnetic-pyrites,		4.200		
ironstone,		4.939		
Malachite,	<i>Brisson.</i>	3.572		
compact,	<i>Brisson.</i>	3.641		
	<i>Muschenbroek.</i>	3.994		
	<i>Bergman.</i>	6.850		
	<i>Hielm.</i>	7.000		
Manganese, gray ore of, striated,				
gray, foliated,				
red from Kapnick,				
black,				
penetrated with water,				
scaly,				
Maple wood,				
Marble, Pyrenean,				
black Biscayan,				
Brocatelle,				
Castilian,				
Valencian,				
Grenadian white,				
Siennian,				
Roman violet,				
African,				
Italian, violet,				
Norwegian,				
Siberian,				
French,				
Switzerland,				
Egyptian, green,				
yellow of Florence,				
Mastic,				
tree,				
Medlar tree,				
Meerschaum. See Keffekil.				
Melanite, or black garnet,				
Mellilite. See Honeystone,				
Menachanite,				
Mercurial hepatic ore, compact,				
Mercury at 32° of heat,				
at 60°,				
at 212°,				
in a solid state, 40° below 0				
Fahr.				
in a fluid state 47° above 0,				
corrosive muriate of, saturated so-				
lution, temp. 42°,				
natural calx of,				
precipitate per se,				
red,				
mineralized by sulphur, native				
Ethiops. See also Cinna-				
bar,				
Mica, or glimmer,				
Milk, woman's,				
mare's,				
ass's,				
goat's,				
ewe's,				
cow's,				
Mineral from Cornwall, supposed to be zeo-				
lite, at 55° Fahrenheit,				

Of Specific Gravities.

Mineral pitch, elastic, or asphaltum, <i>Hatchet.</i>	{ 0.905
	1.233
<i>La Metherie.</i>	0.930
	0.770
Mineral tallow,	7.500
Molybdena in a metallic state, saturated with water,	<i>Kirwan.</i> 4.048
native,	<i>Shumacher.</i> 4.667
	<i>Brisson.</i> 4.7385
Mountain crystal. See Rock Crystal.	
Mulberry tree, Spanish,	<i>Muschenbroek.</i> 0.8979
Muricalcite, crystallized, or rhomb spar,	2.480
Myrrh,	1.3600

N

Naphtha,	0.8475
Nephrite. See Jade.	
Nickel in a metallic state,	{ 7.421
	8.500
	<i>Bergman.</i> 9.3333
copper,	<i>Brisson.</i> { 6.6086
	6.6481
	<i>Gellert.</i> 7.560
Nickel, ore of, called Kupfernickel of Saxe,	6.648
Kupfernickel of Bohemia,	6.607
sulphurated,	6.620
Nickeline, a metal discovered by Richter,	
cast,	<i>Richter.</i> 8.55
forged,	<i>Richter.</i> 8.60
Nigrine, or calcareo-siliceous titanite ore,	<i>Vauquelin.</i> 3.700
	<i>Klaproth.</i> 4.445
	<i>Lowitz.</i> 4.673
Nitre,	<i>Muschenbroek.</i> 1.9000
quadrangular,	<i>Muschenbroek.</i> 2.2460
saturated solution of temperature 42°	
	<i>Watson.</i> 1.095
Novaculite, or Turkey hone. See Slate, Whet.	

O

Oak, 60 years old, heart of,	<i>Muschenbroek.</i> 1.1700
Obsidian, or Icelandic agate. See Lapis Obsidianus.	
Octahedrite,	<i>Häuy.</i> 3.857
Oil of filberts,	0.916
walnut,	0.9227
hemp-seed,	0.9258
poppies,	0.9238
rape-seed,	0.9193
lint-seed,	0.9403
poppy-seed,	0.929
whale,	0.9233
ben, a tree in Arabia,	0.9119
beechmast,	0.9176
codfish,	0.9233
olives,	0.9153
almonds, sweet,	0.9179
volatile, of mint, common,	0.8982
volatile, of sage,	0.9016
thyme,	0.9023
rosemary,	0.9057
calamint,	0.9116
cochlearia,	0.9427
wormwood,	0.9073

Oil, volatile of, tansy,	0.9328
Stragan,	0.9949
Roman camomile,	0.8943
sabine,	0.9294
fennel,	0.9294
fennel-seed,	1.0083
coriander-seed,	0.8655
caraway-seed,	9.9049
dill-seed,	0.9128
anise-seed,	0.9867
juniper-seed,	0.8577
cloves,	1.0363
ciunnamon,	1.0439
turpentine,	0.8697
amber,	0.8865
the flowers of orange,	0.8798
lavender,	0.8938
hysop,	0.8892

Olibanum, gum,	1.1732
Olive tree,	<i>Muschenbroek.</i> 0.9270
copper ore, foliated,	<i>Boarnon.</i> 4.281
fibrous,	<i>Bournon.</i> 4.281
	<i>Werner.</i> 3.225
Olivine,	<i>Blumenbach.</i> 2.114
Opal, precious,	
common,	<i>Klaproth.</i> { 1.958
	2.015
	<i>Kirwan.</i> 2.144
semiopal, reddish, from Telkoba-	
nya,	<i>Klaproth.</i> 2.540
ligniform, or wood,	2.600

Opium,	1.3365
Ophites. See Porphyry Horablende.	
Opoponax,	1.6226
Orange tree,	<i>Muschenbroek.</i> 0.7059
Orpiment,	<i>Kirwan.</i> { 3.048
	3.435
Orpiment, red. See Realgar.	

P

Pear trees,	<i>Muschenbroek.</i> 0.6610
Pearls, oriental,	2.683
Peat, hard,	1.329
Peruvian bark,	0.7840
Petrol,	0.8783
Petrosilex. See Hornstone.	
Phosphorite, or Spargel stone, whitish, from Spain, before absorbing water,	2.8249
after absorbing water,	2.8648
greenish, from Spain,	3.098
Saxon,	3.218
Phosphorus,	1.714
Pierre de valvic,	2.320
Pinite,	<i>Kirwan.</i> 2.980
Pitch ore, or sulphurated uranite,	<i>Guyton.</i> 6.378
	<i>Häuy.</i> 6.530
	<i>Klaproth.</i> 7.500
Pitch-stone, black,	<i>Brisson.</i> 2.0499
yellow,	<i>Brisson.</i> 2.0860
red,	<i>Brisson.</i> 2.6695
brick red, from Misnia,	<i>Kirwan.</i> 2.720
leek green, inclining to olive,	<i>Kirwan.</i> 2.298
pearl gray,	<i>Kirwan.</i> 1.970
blackish,	<i>Brisson.</i> 2.3191
	Pitch-stone,

chap. II.

HYDRODYNAMICS.

of Specific Gravities.

	pyramidal, (pauant gris), (pauant noir), or flos ferri,	2.7141 2.7121 2.6207 2.6747	Sylvan, native,	<i>Jacquin, jun.</i> 4.107 <i>Muller.</i> 5.723 <i>Klaproth.</i> 6.115 <i>Muller.</i> 10.678 <i>Jacquin, jun.</i> 6.157 <i>Muller.</i> 8.919 <i>Muschenbroeck.</i> 1.0989	Of Spe Gravit
Spargel stone.	See Phosphorite.		ore, yellow, black,		
Spermaceti,		9.9433	Syringa,		
Spinelle,	<i>Klaproth.</i> <i>Wiedemann.</i>	3.570 3.700			
Spirit of wine.	See Alcohol.				
Spodumene,	<i>Häuy.</i> <i>Dandrada.</i>	3.192 3.218			
Stalactite, transparent, opaque,		2.3239 2.4783	Tacamahaca, resin,		1.0463
	penetrated with water,	2.5462	Talc, black crayon, ditto German, yellow, white, of mercury, black, earthy, common Venetian,		2.080 2.246 2.655 2.704 2.7917 2.9004 2.6325 2.700 2.800
Staurolite.	See Cross-stone.		Tallow,		0.9419
Staurotite, or grenatite,	<i>Häuy.</i>	3.286	Tantalite,	<i>Eckeberg.</i>	7.953
Steatites of Bareight,		2.6149	Tartar,	<i>Muschenbroeck.</i>	1.8490
	penetrated with water,	2.6657	Terra Japonica,		1.3980
	indurated,	2.5834	Thumserstone,	<i>Häuy,</i> { <i>Gerhard.</i> 3.250 <i>Kirwan.</i> 3.2956	3.213 3.300
	penetrated with water,	2.6322			
Steel, soft,		7.8331	Tin, pure, from Cornwall, fused,	<i>Watson.</i> {	7.170 7.291
hammered,		7.8404		fused and hammered,	7.291
hardened in water,		7.8163	of Malacca, fused,		7.296
hammered and then hardened in water,		7.8180		fused and hammered,	7.306
St John's wort, inspissated juice of,		1.5263	of Galicia,	<i>Gellert.</i>	7.063
Strontian,	<i>Kirwan.</i> { <i>Klaproth.</i>	3.400 3.644 3.675	of Ehrenfriedensdorf in Saxony, pyrites,	<i>Gellert.</i> <i>Klaproth.</i> <i>La Metheric.</i>	7.271 4.350 4.785
Stone, sand, paving, grinding, cutlers,		2.4158 2.1429 2.1113	stone,	<i>Gellert.</i> {	6.300 6.989
Fountaiableau, glittering,		2.5616		<i>Brunich.</i> <i>Leyser.</i> <i>Brisson.</i> <i>Brisson.</i>	6.750 6.880 6.901 6.9348
	crystallized,	2.6111	black, red,	<i>Klaproth.</i> {	5.845 6.970
scythe, of Auvergne, mean grained,		2.5638		<i>Werner.</i> <i>Brunich.</i> <i>Blumenbach.</i>	7.000 5.800 6.450
	fine grained,	2.6090	fibrous,		7.3013
	coarse grained,	2.5686		new, fused, fused and hammered,	7.3115
Lorraine,		2.5298		fine, fused, fused and hammered,	7.4789 7.5194
Liege,		2.6356		common, called <i>Clair-etoffe</i> ,	7.9200 8.4869
mill,		2.4835	ore, Cornish,	<i>Brunich.</i> <i>Klaproth.</i>	5.800 6.450
Bristol,		2.510	stone, white,		6.008
Burford,		2.049	Titanite. See Rutile.		
Portland,		2.496	Topaz, oriental		4.0106
rag,		2.470	Brazilian,		3.5365
rotten,		1.981	from Saxony,		3.5640
St Cloud,		2.201	oriental pistachio,		4.0615
St Maur,		2.034	Saxony white,		3.5535
Notre Dame,		2.378	Tourmaline. See Short.		
Clicard from Brachet, Ouchain,		2.357 2.274	Tungsten,	<i>Leyser.</i>	4.355
rock of Chatillon,		2.122			Tungsten,
hard paving,		2.460			
Siberian blue,		2.945			
touch,		2.415			
prismatic basaltes, of the quarry of Bourè, of Charence,		2.722 1.3864 2.4682			
Storax,		1.1098			
Sugar, white,	<i>Muschenbroeck.</i>	1.6060			
Sulphur, native, fused,		2.0332 1.9907			
Sulphuric or vitriolic acid,		1.841			
Sulphurate, triple, of lead, antimony, and cop- per,	<i>Hatchet.</i>	5.766			
Sylvanite, or tellurite, in a metallic state, twice fused,		6.343			

Of Specific Gravities.

Tungsten,

Kirwan. { 5.800
6.028
Brisson. { 6.066
6.015
Klaproth. { 5.570
8.235

Turbeth mineral, 0.870
Turpentine, spirits of, 0.991
liquid,
Turquoise, ivory tinged by the blue calx of copper, { 2.500
2.908

U

Ultramarine, Desormes and Clement. 2.360
Uran, Mica, Champeaus. 3.1212
Uranite in a metallic state, Klaproth. 6.440
sulphurated. See Pitch ore.
Uranitic ochre, indurated, La Metheric. 3.150
Häuy. 3.2438
Uranium, stone of, { 7.500
1.015
Urine, human, { 1.026

V

Vermeille, a kind of oriental ruby, 4.2299
Vesuvian, Wiedemann. 3.575
Klaproth. 3.420
of Siberia, Klaproth. { 3.365
3.339
Häuy. 3.497
Vine, Muschenbroek. 1.2370
Vinegar, red, Muschenbroek. 1.0251
white, 1.0135
Vitriol, Dantzic, 1.715

W

Walnut-tree of France, Muschenbroek. 0.6710
Water distilled at 32° temperature, 1.0000
sea, 1.0263
of Dead sea, 1.2403
wells, 1.0017
of Bareges, 1.00037
of the Seine, filtered, 1.00015
of Spa, 1.0009
of Armeil, 1.00046
Avray, 1.00043
Seltzer, 1.0035
Wavellite, or hydragillite, Davy. 2.7000
Wax, Ourouchi, 9.8979
bees, 0.9648

Wax, white, shoesmakers, 0.9686
Whey, cows, 0.897
Willow, 1.019
Witherite. See Barolite.
Wine of Torrins, red, white, 0.9930

Muschenbroek.

Champagne, white, 0.9876
Pakaret, 0.9979
Xeret, 0.9997
Malmsy of Madeira, 0.9924
Burgundy, 1.0382
Jurancon, 0.9915
Bordeaux, 0.9932
Malaga, 0.9939
Constance, 1.0221
Tokay, 1.0819
Canary, 1.0538
Port, 1.033
0.997

Wolfram,

Gmelin. 5.705
Elhuyar. 6.835
Leonhardt. 7.000
Hatchet. 6.955
Häuy. 7.333

Wolf's eye (name of a mineral), 2.3507
Woodstone, 2.045
2.675

Y

Yew tree, Dutch, Muschenbroek. 0.7880
Spanish, Muschenbroek. 0.8070
Yttertantalite, Eskeberg. 5.130

Z

Zeolite from Edelfors, red, scintillant, 2.4868
white scintillant, 2.0739
compact, 2.1344
radiated, Häuy. 2.083
cubic, Häuy. 2.716
siliceous, 2.515
Zinc, pure and compressed, 7.1908
in its usual state, 6.862
formed by sublimation and full of cavities, Kirwan. 5.918
sulphate of Muschenbroek. 1.9000
saturated solution of, temp. 42°, Watson. 1.386
Zircon, or jargon, Klaproth. 4.615
Karsten. 4.666
Wiedemann. 4.700

Fluids do not rise to the same level in a system of communicating vessels when their diameters are very minute.

CHAP. III. On Capillary Attraction, and the Cohesion of Fluids.

III. WE have already seen, when discussing the equilibrium of fluids, that when water or any other fluid is poured into a vessel, or any number of communicating vessels, its surface will be horizontal, or it will rise to the same height in each vessel, whatever be its form or position. This proposition, however, only holds true when the diameter of these vessels or tubes exceeds the

fifteenth of an inch: for if a system of communicating vessels be composed of tubes of various diameters, the fluid will rise to a level surface in all the tubes which exceed one-fifteenth of an inch in diameter; but in the tubes of a smaller bore, it will rise above that level to altitudes inversely proportional to the diameters of the tubes. The power by which the fluid is raised above its natural level is called *capillary attraction*, and the glass tubes which are employed to exhibit its phenomena are named *capillary tubes*. These appellations derive their origin from the Latin word *capillus*, signifying a hair, either

Capillary Attraction, &c.

either because the bores of these tubes have the fineness of a hair, or because that substance is itself supposed to be of a tubular structure.

112. When we bring a piece of clean glass in contact with water or any other fluid, except mercury and fused metals, and withdraw it gently from its surface, a portion of the fluid will not only adhere to the glass, but a small force is necessary to detach this glass from the fluid mass, which seems to resist any separation of its parts. Hence it is obvious that there is an attraction of cohesion between glass and water, and that the constituent particles of water have also an attraction for each other. The suspension of a drop of water from the lower side of a plate of glass is a more palpable illustration of the first of these truths; and the following experiment will completely verify the second. Place two large drops of water on a smooth metallic surface, their distance being about the tenth of an inch. With the point of a pin unite these drops by two parallel canals, and the drops will instantly rush to each other through these canals, and fill the dry space that intervenes. This experiment is exhibited in fig. 2. where AB is the metallic plate, C, D the drops of water, and *m*, *n* the two canals.

There is an attraction of cohesion between glass and water, and between the particles of water.

Plate CCLXVI. fig. 2.

113. Upon these principles many attempts have been made to account for the elevation of water in capillary tubes; but all the explanations which have hitherto been offered, are founded upon hypothesis, and are very far from being satisfactory. Without presuming to substitute a better explanation in the room of those which have been already given, and so frequently repeated, we shall endeavour to illustrate that explanation of the phenomena of capillary attraction which seems liable to the fewest objections. For this purpose let E be a drop of water laid upon a clean glass surface AB. Every particle of the glass immediately below the drop E, exerts an attractive force upon the particles of water. This force will produce the same effect upon the drop as a pressure in the opposite direction, the pressure of a column of air, for instance, on the upper surface of the drop. The effect of the attractive force, therefore, tending to press the drop to the glass will be an enlargement of its size, and the water will occupy the space FG; this increase of its dimensions will take place when the surface AB is held downwards; and that it does not arise from atmospheric pressure may be shown by performing the experiment *in vacuo*. Now let AB (fig. 2.) be a section of the plate of glass AB (fig. 3.) held vertically, part of the water will descend by its gravity, and form a drop B, while a small film of the fluid will be supported at *m* by the attraction of the glass. Bring a similar plate of glass CD into a position parallel to AB, and make them approach nearer and nearer each other. When the drops B and D come in contact, they will rush together from their mutual attraction, and will fill the space *op*. The gravity of the drops B and D being thus diminished, the film of water at *m* and *s* which was prevented from rising by their gravity will move upwards. As the plates of glass continue to approximate, the space between them will fill with water, and the films at *m* and *s* being no longer prevented from yielding to the action of the glass immediately below them (by the gravity of the water at *op*, which is diminished by the mutual action of the

Attempt to account for the rise of water in capillary tubes. Fig. 2.

Fig. 5.

VOL. X. Part II.

fluid particles) will rise higher in proportion to the approach of the plates. Hence it may be easily understood how the water rises in capillary tubes, and how its altitude is inversely as their internal diameters. For let A, *a* be the altitudes of the fluid in two tubes of different diameters D, *d*; and let C, *c* be the two cylinders of fluid which are raised by virtue of the attraction of the glass. Now, as the force which raises the fluid must be as the number of attracting particles, that is, as the surface of the tube in contact with the water, that is, as the diameter of the tubes, and as this same force must be proportional to its effects on the cylinder of water raised, we shall have $D : d :: C : c$. But (GEOMETRY, Sect. VIII. Theor. XL. Sect. IX. Theor. II.) $C : c :: D^2 A : d^2 a$, therefore $D^2 A : d^2 a :: D : d$; hence $D^2 A d = d^2 a D$, and $DA = \frac{d^2 a D}{D d}$, or $DA = da$, that is, $D : d :: a : A$, or the altitudes of the water are inversely as the diameters of the tubes. Since $DA = da$, the product of the diameter by the altitude of the water will always be a constant quantity. In a tube whose diameter is 0.01, or $\frac{1}{100}$ of an inch, the water has been found to reach the altitude of 5.3 inches; hence the constant quantity $5.3 \times 0.1 = 0.053$ may fitly represent the attraction of glass for water. According to the experiments of Muschenbroek, the constant quantity is 0.039; according to Weithrecht 0.0428; according to Monge 0.042, and according to Atwood 0.0530. When a glass tube was immersed in melted lead, Gellert found the depression multiplied by the bore to be 0.0054.

Capillary Attraction, &c.

The altitudes of fluids in capillary tubes are inversely as their diameters.

114. Having thus attempted to explain the causes of capillary action, we shall now proceed to consider some of its most interesting phenomena. In fig. 4. MN is a vessel of water in which tubes of various forms are immersed. The water will rise in the tubes A, B, C to different altitudes *m*, *n*, *o*, inversely proportional to their diameters. If the tube B is broken at *a*, the water will not rise to the very top of it at *a*, but will stand at *b*, a little below the top, whatever be the length of the tube or the diameter of its bore. If the tube be taken from the fluid and laid in a horizontal position, the water will recede from the end that was immersed. These two facts seem to countenance the opinion of Dr Jurin and other philosophers, that the water is elevated in the tube by the attraction of the annulus, or ring of glass, immediately above the cylinder of water. This hypothesis is sufficiently plausible; but supposing it to be true, the ring of glass immediately below the surface of the cylinder of fluid should produce an equal and opposite effect, and therefore the water instead of rising should be stationary, being influenced by two forces of an equal and opposite kind.

Phenomena of capillary attraction. Fig. 4.

Jurin's hypothesis. Phil. Trans. N^o 363.

115. If a tube D composed of two cylindrical tubes of different bores be immersed in water with the widest part downwards, the water will rise to the altitude *p*, and if another tube E of the same size and form be plunged in the fluid with the smaller end downwards, the water will rise to the same height *q* as it did in the tube D. This experiment seems to be a complete refutation of the opinion of Dr Jurin, that the water is raised by the action of the annulus of glass above the fluid column; for since the annular surface is the same at *q* as at *p*, the same quantity of fluid ought to be supported in both tubes, whereas the tube E evidently

Phenomena of capillary attraction.

4 Z

Capillary Attraction, &c.

raises much less water than D. But if we admit the supposition in art. 113. that the fluid is supported by the whole surface of glass in contact with the water, the phenomenon receives a complete explanation; for since the surface of glass in contact with the fluid in the tube E is much less than the surface in contact with it in the tube D, the quantity of fluid sustained in the former ought to be much less than the quantity supported in the latter.

Phenomena of capillary attraction.

116. When a vessel Fvw is plunged in water, and the lower part *tuvw* filled by suction till the fluid enter the part Ft, the water will rise to the same height as it does in the capillary tube G, whose bore is equal to the bore of the part Ft. In this experiment the portions of water *tux* and *uxw* on each side of the column *Fx* are supported by the pressure of the atmosphere on the surface of the water in the vessel MM; for if this vessel be placed in the exhausted receiver of an air-pump, these portions of water will not be sustained. Dr Jurin, indeed, maintains that these portions will retain their position *in vacuo*, but in his time the exhausting power of the air-pump was not sufficiently great to determine a point of so great nicety. The column *tux*, which is not sustained by atmospherical pressure, is kept in its position by the attraction of the water immediately around and above it, and the column *Ftu* is supported by the attraction of the glass surface with which it is in contact. According to Dr Jurin's hypothesis, the column *tux* is supported by the ring of glass immediately above *r*, which is a very unlikely supposition.

Fig. 4.

Hypothesis of Dr Hamilton and Dr Matthew Young.

117. The preceding experiment completely overturns the hypothesis of Dr Hamilton, afterwards revived by Dr Matthew Young. These philosophers maintained that the fluid was sustained in the tube by the lower ring of glass contiguous to the bottom of the tube, that this ring raises the portion of water immediately below it, and then other portions successively till the portion of water thus raised be in equilibrium with the attraction of the annulus in question. But if the elevation of the fluid were produced in this way, the quantity supported would be regulated by the form and magnitude of the orifice at the bottom of the tube; whereas it is evident from every experiment, that the cylinder of fluid sustained in capillary tubes has no reference whatever to the form of the lower annulus, but depends solely upon the diameter of the tube immediately above the elevated column of water.

The capillary phenomena take place in the exhausted receiver of an air-pump.

118. If the experiments which we have now explained be performed in the exhausted receiver of an air-pump, the water will rise to the same height as when they are performed in air. We may therefore conclude, that the ascent of the water is not occasioned, as some have imagined, by the pressure of the atmosphere acting more freely upon the surface of the water in the vessel than upon the column of fluid in the capillary tube.

Experiments of Mr B. Martin on the ascent of different fluids in capillary tubes.

119. It appears from the following table constructed by Mr B. Martin, that different fluids rise to very different heights in capillary tubes, and that spirituous liquors, whose specific gravity is less than that of water, are not raised to the same altitude. Mr Martin's experiments were made with a tube about $\frac{1}{7}$ of an inch in diameter. He found that when capillary tubes charged with different fluids were suspended in the sun for months together, the enclosed fluid was not in the least degree diminished by evaporation.

Names of the Fluids.

	Alth.	Constant Number
Common spring water	Inches 1.2	.048
Spirit of urine	1.1	.044
Tincture of galls	1.1	.044
Recent urine	1.1	.044
Spirit of salt	0.9	.036
Ol. tart. per deliq.	0.9	.036
Vinegar	0.95	.038
Small beer	0.9	.036
Strong spirit of nitre	0.85	.034
Spirit of hartshorn	0.85	.034
Cream	0.8	.032
Skimmed milk	0.8	.032
Aquafortis	0.75	.030
Red wine	0.75	.030
White wine	0.75	.030
Ale	0.75	.030
Ol. sul. per campanam	0.65	.026
Oil of vitriol	0.65	.026
Sweet oil	0.6	.024
Oil of turpentine	0.55	.022
Geneva	0.55	.022
Rum	0.5	.020
Brandy	0.5	.020
White hard varnish	0.5	.020
Spirit of wine	0.45	.018
Tincture of mars	0.45	.018

Capillary Attraction, &c.

120. To the preceding table as given by Mr Martin we have added the constant number for each fluid, or the product of the altitude of the liquid, and the diameter of the tube (art. 115.). By this number, therefore, we can find the altitude to which any of the preceding fluids will rise in a tube of a given bore, or the diameter of the bore when the altitude of the fluid is known; for since the constant number $C=DA$ (art. 113.) we shall have

$$D = \frac{C}{A} \text{ and } A = \frac{C}{D}$$

Since the constant number, however, as deduced from the experiments of Martin, may not be perfectly correct, it would be improper to derive from it the diameter of the capillary bore when great accuracy is necessary. The following method, therefore, may be adopted as the most correct that can be given. Put into the capillary tube a quantity of mercury, whose weight in troy grains is *W*, and let the length *L* of the tube which it occupies be accurately ascertained; then if the mercury be pure and at the temperature of 60° of Fahrenheit, the diameter of the

Method of measuring the internal diameter of a capillary tube.

tube $D = \sqrt{\frac{W}{L}} \times 0.019241$, the specific gravity of mercury being 13.580. The weight of a cubic inch of mercury being 3438 grains, and the solid content of the mercurial column being $D^2L \times 0.7854$, we shall have $1 : 3438 = D^2L \times 0.7854 : W$. Hence (GEOMETRY, Sect. IV. Theor. VIII.) $D^2L \times 0.7854 \times 3438 = W$, and dividing we have $D^2 = \frac{W}{L \times 0.7854 \times 3438}$

$$\text{or } D = \sqrt{\frac{W}{L \times 0.7854 \times 3438}} \text{ or } D = \sqrt{\frac{W}{L}} \times 0.019241$$

If the whole tube be filled with mercury, and if *W* be the difference in troy grains between its weight when empty.

Capillary Attraction, &c. empty, and when filled with mercury, the same theorem will serve for ascertaining the diameter of the tube. Should the temperature of the mercury happen to be 32° of Fahrenheit, its specific gravity will be 13.619, which will alter a very little the constant multiplier 0.019241.

The motion of water in capillary tubes accelerated by electricity and by heat. 121. When water is made to pass through a capillary tube of such a bore that the fluid is discharged only by successive drops; the tube, when electrified, will furnish a constant and accelerated stream, and the acceleration is proportional to the smallness of the bore. A similar effect may be produced by employing warm water. Mr Leslie found that a jet of warm water rose to a much greater height than a jet of cold water, though the water in both cases moved through the same aperture, and was influenced by the same pressure. A syphon also which discharged cold water only by drops, yielded warm water in an invariable stream.

On the ascent of fluids between two inclined plates of glass. 122. Such are the leading phenomena of capillary tubes. The rise of fluids between two plates of glass remains to be considered; and while it furnishes us with a very beautiful experiment, it confirms the reasoning by which we have accounted for the elevation of fluids in cylindrical canals. Let ABEF and CDEF be two pieces of plate glass with smooth and clean surfaces, having their sides EF joined together with wax, and their sides AB, CD kept a little distance by another piece of wax W, so that their interior surfaces, whose common intersection is the line EF, may form a small angle. When this apparatus is immersed in a vessel MN full of water, the fluid will rise in such a manner between the glass panes as to form the curve DgomE, which represents the surface of the elevated water. By measuring the ordinates m, n, o, p , &c. of this curve, and also its abscissæ $F n, F p$, &c. Mr Hawksbee found it to be the common Apollonian hyperbola, having for its asymptotes the surface DE of the fluid, and EF the common intersection of the two plates. To the very same conclusion we are led by the principles already laid down; for as the distance between the plates diminishes at every point of the curve DgomE from D towards E, the water ought to rise higher at o than at q , still higher at m , and highest of all at E, where the distance between the plates is a minimum. To illustrate this more clearly, let ABEF and CDEF be the same plates of glass, (inclined at a greater angle for the sake of distinctness) and let EmqD, and EosB be the curves which bound the surface of the elevated fluid. Then, since the altitudes of the water in capillary tubes are inversely as their diameters or the distances of their opposite sides, the altitudes of the water between two glass plates, should at any given point be inversely as the distances of the plates at that point. Now, the distance of the plates at the point m is obviously mo , or its equal np , and the distance at q is qs or rt ; and since mn is the altitude of the water at m , and qr its altitude at q , we have $mn : qr = np : rt$; but (GEOMETRY, Sect. IV. Theor. XVII.) $F n : F r = np : rt$; therefore $mn : qr = F n : F r$, that is, the altitudes of the fluid at the points m, q , which are equal to the abscissæ $F n, F r$ (fig. 5.) are proportional to the ordinates qr, mn , equal to $F n, F r$, in fig. 5. But in the Apollonian hyperbola the ordinates are inversely proportional to their respective abscissæ, therefore the curve DgomE is the

Plate CGI. XVL fig. 5.

Fig. 6.

common hyperbola.—As the plates are infinitely near each other at the apex E, the water will evidently rise to that point, whatever be the height of the plates. Capillary Attraction, &c.

123. The phenomena which we have been endeavouring to explain, are all referable to one simple fact, that the particles of glass have a stronger attraction for the particles of water than the particles of water have for each other. This is the case with almost all other fluids except mercury, the particles of which have a stronger attraction for each other than for glass. When capillary tubes therefore are plunged in this fluid, a new series of phenomena present themselves to our consideration. Let MN (fig. 7.) be a vessel full of mercury. Plunge into the fluid the capillary tube CD, and the mercury, instead of rising in the tube, will remain stationary at E, its depression below the level surface AB being inversely proportional to the diameter of the bore. This was formerly ascribed to a repulsive force supposed to exist between mercury and glass, but we shall presently see that it is owing to a very different cause. Mercury descends in capillary tubes. Fig. 7.

124. That the particles of mercury have a very strong attraction for each other, appears from the globular form which a small portion of that fluid assumes, and from the resistance which it opposes to any separation of its parts. If a quantity of mercury is separated into a number of minute parts, all these parts will be spherical; and if two of these spheres be brought into contact, they will instantly rush together, and form a single drop of the same form. There is also a very small degree of attraction existing between glass and mercury; for a globule of the latter very readily adheres to the lower surface of a plate of glass. Now suppose a drop of water laid upon a surface anointed with grease, to prevent the attraction of cohesion from reducing it to a film of fluid, this drop, if very small, will be spherical. If its size is considerable, the gravity of its parts will make it spheroidal, and as the drop increases in magnitude, it will become more and more flattened at its poles, like AB in fig. 8. The drop, however, will still retain its convexity at the circumference, however oblate be the spheroid into which it is moulded by the force of gravity. Let two pieces of glass $o A m, p B n$, be now brought in contact with the circumference of the drop; the mutual attraction between the particles of water which enabled it to preserve the convexity of its circumference, will yield to their superior attraction for glass; the space m, n, o, p , will be immediately filled; and the water will rise on the sides of the glass, and the drop will have the appearance of AB in fig. 9. If the drop AB fig. 8. be now supposed mercury instead of water, it will also, by the gravity of its parts, assume the form of an oblate spheroid; but when the pieces of glass $o A m, p B n$ are brought close to its periphery, their attractive force upon the mercurial particles is not sufficient to counteract the mutual attraction of these particles; the mercury therefore retains its convexity at the circumference, and assumes the form of AB in fig. 10. The small spaces o, p being filled by the pressure of the superincumbent fluid, while the spaces m, n , still remain between the glass and the mercury. Now if the two plates of glass, A, B be made to approach each other, the depressions m, n will still continue, and when the distance of the plates is so small that these depressions or indentations meet, the mercury Cause of the depression of mercury in capillary tubes. Fig. 8.

Fig. 9. Fig. 10.

Capillary will sink between the plates, and its descent will continue as the pieces of glass approach. Hence the depression of the mercury in capillary tubes becomes very intelligible.—If two glass planes forming a small angle, as in fig. 5. bb immersed in a vessel of mercury, the fluid will sink below the surface of the mercury in the vessel, and form an Apollonian hyperbola like D o E, having for its asymptotes the common intersection of the planes and the surface of mercury in the vessel.

The depression of mercury in glass tubes, owing ultimately to an imperfect contact between the solid and the fluid.

125. The depression of mercury in capillary tubes is evidently owing to the greater attraction that subsists between the particles of mercury, than between the particles of mercury and those of glass. The difference between these two attractions, however, arises from an imperfect contact between the mercury and the capillary tube, occasioned by the interposition of a thin coating of water which generally lines the interior surface of the tube, and weakens the mutual action of the glass and mercury; for this action always increases as the thickness of the interposed film is diminished by boiling. In the experiments which were made by Laplace and Lavoisier on barometers, by boiling the mercury in them for a long time, the convexity of the interior surface of the mercury was often made to disappear. They even succeeded in rendering it concave, but could always restore the convexity by introducing a drop of water into the tube. When the ebullition of the mercury is sufficiently strong to expel all foreign particles, it often rises to the level of the surrounding fluid, and the depression is even converted into an elevation.

Capillary attraction does not seem to act at any perceptible distance.

126. Newton, Clairaut, and other geometers, have maintained, that the action of the capillary tube is sensible at a small distance, and that it is extended to the particles of fluid in the axis of the tube. Laplace and other philosophers who have lately attended to this subject, suppose capillary attraction to be like the refractive force, and all the chemical affinities, which are not sensible except at imperceptible distances; and it must be allowed that this opinion is consistent with many of the phenomena. It has been often observed that water rises to the same height in glass tubes, of the same bore, whether they be very thin or very thick. The zones of the glass tube therefore, which are at a small distance from the interior surface, do not contribute to the ascent of the water, though in each of these zones, taken separately, the water would rise above its level. When the interior surface of a capillary tube is lined with a very thin coating of an unctuous substance, the water will no longer ascend. Now if the attraction of the glass tube were similar to the attraction of gravity, of electricity, or magnetism, it ought to act through bodies of all kinds, and, notwithstanding the thin coating of grease, should elevate the fluid in which it is immersed. But as the intervention of an attenuated film of grease destroys capillary action, there is reason to conclude, that it does not extend to sensible distances. The same conclusion is deducible from the fact in the preceding paragraph.

Opinion of Laplace.

127. From these facts Laplace concludes, that the attraction of capillary tubes has not any influence on the elevation or depression of the fluids which they contain, except by determining the inclination of the first planes of the surface of the interior fluid, which are extremely near the sides of the tube. He supposes that when

the attraction of the tube upon the fluid exceeds the attraction of the fluid upon itself, the fluid will in that case attach itself to the tube, and form an anterior tube, which alone will raise the fluid.

128. 'It is interesting, says Laplace, to ascertain the radius of curvature of the surface of water included in capillary tubes of glass. This may be known by a curious experiment, which shews at the same time the effects of the concavity and convexity of surfaces. It consists in plunging in water, to a known depth, a capillary tube of which the diameter is likewise known. The lower extremity of the tube is then to be closed with the finger, and the tube being taken out of the water, its external surface must be gently wiped. Upon withdrawing the finger in this last situation, the water is seen to subside in the tube and form a drop at its lower base; but the height of the column is always greater than the elevation of the water in the tube above the level in the common experiment of plunging it in water. This excess in the height is owing to the action of the drop upon the column on account of its convexity; and it is observable that the increase in the elevation of the water is more considerable, the smaller the diameter of the drop beneath. The length of the fluid column which came out by subsidence to form the drop, determines its mass; and as its surface is spherical as well as that of the interior fluid, if we know the height of the fluid above the summit of the drop, and the distance of this summit from the plane of the interior bore of the tube, it will be easy to deduce the radii of these two surfaces. Some experiments lead me to conclude that the surface of the interior fluid approaches very nearly to the figure of an hemisphere.'

129. 'The theory which I have adopted, observes the same philosopher, likewise gives the explanation and measure of a singular phenomenon presented by experiment. Whether the fluid be elevated or depressed between two vertical planes, parallel to each other, and plunged in the fluid at their lower extremities, the planes tend to come together. Analysis shews us, that if the fluid be raised between them, each plane will undergo from without inwards a pressure equal to that of a column of the same fluid, of which the height would be half the sum of the elevations above the level of the points of contact of the interior and exterior surfaces of the fluids with the plane, and of which the base should be the parts of the plane comprised between the two horizontal lines drawn through those points. If the fluid be depressed between the planes, each of them will in like manner undergo from without inwards, a pressure equal to that of a column of the same fluid, of which the height would be half the sum of the depressions below the level of the points of contact of the interior and exterior surfaces of the fluid with the plane, and of which the base should be the part of the plane comprised between the two horizontal lines drawn through those points.'

130. As most philosophers seem to agree in thinking that all the capillary phenomena are referable to the cohesive attraction of the superficial particles only of the fluid, a variety of experiments has been made in order to determine the force required to raise a horizontal solid surface from the surface of a fluid. Mr Achard found that a disc of glass, 1 1/2 French inches in diameter, required a weight of 91 French grains to raise

Capill. Attract. &c.

When a fluid is elevated or depressed between two parallel vertical planes, it tends to come together.

Achard's experiment on the force necessary to raise a solid surface from the surface of water.

Capillary
Attraction,
&c.

it from the surface of the water at 69° of Fahrenheit, which is only 37 English grains for each square inch. At 44½ of Fahrenheit the force was $\frac{1}{2}$ greater, or 39½ grains, the difference being $\frac{1}{2}$ for each degree of Fahrenheit. From these experiments Dr Young concludes that the height of ascent in a tube of a given bore, which varies in the duplicate ratio of the height of adhesion, is diminished about $\frac{1}{100}$ for every degree of Fahrenheit that the temperature is raised above 50°; and he conjectures that there must have been some considerable source of error in Aohard's experiments, as he never found this diminution to exceed $\frac{1}{1000}$. According to the experiments of Dutour, the force necessary to elevate the solid, or the quantity of water raised, is equal to 44.1 grains for every square inch.

Morveau's
experi-
ments on
the force
necessary
to raise me-
tals from
the surface
of mercury.

131. According to the experiments of Morveau, the force necessary to elevate a circular inch of gold from the surface of mercury is 446 grains; a circular inch of silver, 429 grains; a circular inch of tin, 418 grains; a circular inch of lead, 397 grains; a circular inch of bismuth, 372 grains; a circular inch of zinc, 204 grains; a circular inch of copper, 142 grains; a circular inch of metallic antimony, 126; a circular inch of iron, 115 grains; and a similar surface of cobalt required 8 grains. The order in which these metals are arranged is the very order in which they are most easily amalgamated with mercury.

On the ap-
parent at-
traction of
floating bo-
dies.

132. The approach of two floating bodies has been ascribed by some to their mutual attraction, and by others to the attraction of the portions of fluid that are raised round each by the attraction of cohesion. Dr Young, however, observes that the approach of the two floating bodies is produced by the excess of the atmospheric pressure on the remote sides of the solids, above its pressure on their neighbouring sides; or, if the experiments are performed in a vacuum, by the equivalent hydrostatic pressure or suction derived from the weight and immediate cohesion of the intervening fluid. This force varies alternately in the inverse ratio of the square of the distance; for when the two bodies approach each other, the altitude of the fluid between them is increased in the simple inverse ratio of the distance; and the mean action, or the negative pressure of the fluid on each particle of the surface, is also increased in the same ratio. When the floating bodies are surrounded by a depression, the same law prevails, and its demonstration is still more simple and obvious.

Experi-
ments of
Count
Rumford
on the ad-
hesion of
fluids.

133. A number of experiments on the adhesion of fluids have been lately made by Count Rumford, which authorise him to conclude, that on account of the mutual adhesion of the particles of fluid, a pellicle or film is formed at the superior and inferior surfaces of water, and that the force of the film to resist the descent of bodies specifically heavier than the fluid increases with the viscosity of the water. He poured a stratum of sulphuric ether upon a quantity of water, and introduced a variety of bodies specifically heavier than water into this compound fluid. A sewing needle, granulated tin, and small globules of mercury, descended through the ether, but floated upon the surface of the water. When the eye was placed below the level of the aqueous surface, the floating body, which was a

Capillary
Attraction,
&c.

spherule of mercury, seemed suspended in a kind of bag a little below the surface. When a larger spherule of mercury was employed, about the 40th or 50th of an inch in diameter, it broke the pellicle and descended to the bottom. The same results were obtained by using essential oil of turpentine or oil of olives instead of ether. When a stratum of alcohol was incumbent upon the water, a quantity of very fine powder of tin thrown upon its surface, descended to the very bottom, without seeming to have met with any resistance from the film at the surface of the water. This unexpected result Count Rumford endeavours to explain by supposing that the aqueous film was destroyed by the chemical action of the alcohol. In order to ascertain with greater accuracy the existence of a pellicle at the surface of the water, Count Rumford employed a cylindrical glass vessel 10 inches high and 1½ inch in diameter, and filled it with water and ether as before. A number of small bodies thrown into the vessel descended through the ether and floated on the surface of the water. When the whole was perfectly tranquil, he turned the cylinder three or four times round with considerable rapidity in a vertical position. The floating bodies turned round along with the glass, and stopped when it was stopped; but the liquid water below the surface did not at first begin to turn along with the glass; and its motion of rotation did not cease with the motion of the vessel. From this Count Rumford concludes that there was a real pellicle at the surface of the water, and that this pellicle was strongly attached to the sides of the glass, so as to move along with it. When this pellicle was touched by the point of a needle, all the small bodies upon its surface trembled at the same time. The apparatus was allowed to stand till the ether had entirely evaporated, and when the pellicle was examined with a magnifier, it was in the same state as formerly; and the floating bodies had the same relative positions.

134. In order to shew that a pellicle was formed at the inferior surface of water, Count Rumford poured water upon mercury, and upon that a stratum of ether. He threw into a vessel a spherule of mercury about one-third of a line in diameter, which being too heavy to be supported by the pellicle at the superior surface of the water, broke it, and descending through that fluid, was stopped at its inferior surface. When this spherule was moved, and even compressed with a feather, it still preserved its spherical form, and refused to mix with the mass of mercury. When the viscosity of the water was increased by the infusion of gum-arabic, much larger spherules were supported by the pellicle. From the very rapid evaporation of ether, and its inability to support the lightest particles of a solid upon its surface, Count Rumford very justly concludes, that the mutual adhesion of its particles is very small.

135. Those who wish to extend their inquiries concerning the cohesion of fluids, may consult an ingenious paper on Capillary Action by Professor Leslie, in the *Phil. Mag.* for 1802; Dr Thomas Young's Essay on the Cohesion of Fluids, in the *Phil. Trans.* 1805; an Abstract of a Memoir of Laplace, in Nicholson's Journal, N° 57.; and an Account of Rumford's Experiments in the same Journal, N° 60, 61, and 62.

PART II. HYDRAULICS.

Definition. 136. **HYDRAULICS** is that branch of the science of hydrodynamics which relates to fluids in motion. It comprehends the theory of running water, whether issuing from orifices in reservoirs by the pressure of the superincumbent mass, or rising perpendicularly in *jets d'eau* from the pressure of the atmosphere; whether moving in pipes and canals, or rolling in the beds of rivers. It comprehends also the resistance or the percussion of fluids, and the oscillation of waves.

CHAP. I. Theory of Fluids issuing from Orifices in Reservoirs, either in a Lateral or a Vertical direction.

Preliminary observations.

Plate CCLXVII.

Fig. 1.

Cause of the vena contracta.

137. IF water issues from an orifice either in the bottom or side of a reservoir, the surface of the fluid in the reservoir is always horizontal till it reaches within a little of the bottom. When a vessel therefore is emptying itself, the particles of the fluid descend in vertical lines, as is represented in fig. 1.; but when they have reached within three or four inches of the orifice mn , the particles which are not immediately above it change the direction of their motion, and make for the orifice in directions of different degrees of obliquity. The velocities of these particles may be decomposed into two others, one in a horizontal direction, by which they move parallel to the orifice, and the other in a vertical direction by which they approach that orifice. Now, as the particles about C and D move with greater obliquity than those nearer E, their horizontal velocities must also be greater, and their vertical velocities less. But the particles near E move with so little obliquity that their vertical are much greater than their horizontal velocities, and very little less than their absolute ones. The different particles of the fluid, therefore, will rush through the orifice mn with very different velocities, and in various directions, and will arrive at a certain distance from the orifice in different times. On account of the mutual adhesion of the fluid particles, however, those which have the greatest velocity drag the rest along with them; and as the former move through the centre of the orifice, the breadth of the issuing column of fluid will be less at op than the width of the orifice mn .

138. That the preceding phenomena really exist when a vessel of water is discharging its contents through an aperture, experience sufficiently testifies. If some small substances specifically heavier than water be thrown into the fluid when the vessel is emptying itself, they will at first descend vertically, and when they come within a few inches of the bottom they will deviate from this direction, and describe oblique curves similar to those in the figure. The contraction of the vein or column of fluid at op is also manifest from observation. It was first discovered by Sir Isaac Newton, and denominated the *vena contracta*. The greatest contraction takes place at a point o whose distance from the orifice is equal to

which was discovered by Newton.

half its diameter, so that $om = \frac{mn}{2}$; and the breadth of the vein or column of fluid at o is to the width of the orifice as 5 to 8 according to Bossut, or as 5.197 to 8 according to the experiments of Michellotti, the orifice being perforated in a thin plate. But when the water is made to issue through a short cylindrical tube, the same contraction, though not obvious to the eye, is so considerable, that the diameter of the contracted vein is to that of the orifice as 6.5 to 8. If A therefore be the real size of the orifice in a thin plate, its corrected size, or the breadth of the contracted vein, will be $\frac{5.197 \times A}{8}$, and when a cylindrical

Description of the vena contracta.

tube is employed it will be $\frac{13 \times A}{16}$. In the first case the height of the water in the reservoir must be reckoned from the surface of the fluid to the point o , where the vein ceases to contract; and when a cylindrical tube is employed, it must be reckoned from the same surface to the exterior aperture of the tube.

139. Suppose the fluid ABCD divided into an infinite number of equal *strata* or *laminæ* by the horizontal surfaces MN, gh infinitely near each other; and let $mno p$ be a small column of fluid which issues from the orifice in the same time that the surface MN descends to gh . The column $mno p$ is evidently equal to the lamina MN gh , for the quantity of fluid which is discharged during the time that MN descends to gh , is evidently MN hg ; and to the quantity discharged in that time, the column $mno p$ was equal by hypothesis. Let A be the area of the base MN, and B the area of the base mn ; let x be the height of a column equal to MN gh , and having A for its base, and let y be the height of the column $mno p$. Then, since the column $mno p$ is equal to the lamina MN gh , we shall have $Ax = By$, and (GEOMETRY, Sect. IV. Theor. IX.) $x : y = A : B$; but as the surface MN descends to gh in the same time that mn descends to op , x will represent the mean velocity of the lamina MN gh , and y the mean velocity of the column $mno p$. The preceding analogy, therefore, informs us, that the mean velocity of any lamina is to the velocity of the fluid issuing from the orifice reciprocally as the area of the orifice is to the area of the base of the lamina MN gh . Hence it follows, that, if the area of the orifice is infinitely small, with regard to the area of the base of the lamina into which the fluid is supposed to be divided, the mean velocity of the fluid at the orifice will be infinitely greater than that of the lamina; that is, while the velocity at the orifice is finite, that of the lamina will be infinitely small.

Relation between the velocity of the fluid at the orifice, and that of the interior laminae.

140. Before applying these principles to the theory of hydraulics, it may be proper to observe, that several distinguished philosophers have founded the science upon the same general law from which we have deduced the principles of hydrostatics (32.). In this way they have represented the motion of fluids in general formulae; but these formulae are so complicated from the

very

Motion of Fluids, &c.

very nature of the theory, and the calculations are so intricate, and sometimes impracticable from their length, that they can afford no assistance to the practical engineer.

these positions will be those due to the heights $E n, F n, G n$, for in these different positions the moving forces are the columns $E m n, F m n, G m n$.

Motion of Fluids, &c.

DEFINITION.

Fig. 1.

141. If the water issues at $m n$ with the same velocity V that a heavy body would acquire by falling freely through a given height H , this velocity is said to be due to the height H , and inversely the height H is said to be due to the velocity V .

144. COR. 1. Since the velocities of the issuing fluid when its surface is at E, F, G , are those due to the heights $E n, F n, G n$, it follows from the properties of falling bodies (see MECHANICS), that if these velocities were continued uniformly, the fluid would run through spaces equal to $2 E n, 2 F n, 2 G n$ respectively, in the same time that a heavy body would fall through $E n, F n, G n$, respectively.

PROP. I.

142. The velocity of a fluid issuing from an infinitely small orifice in the bottom or side of a vessel, is equal to that which is due to the height of the surface of the fluid above that orifice, the vessel being supposed constantly full.

145. COR. 3. As fluids press equally in all directions, the preceding proposition will hold true, when the orifices are at the sides of vessels, and when they are formed to throw the fluid upwards, either in a vertical or an inclined direction, provided that the orifices are in these several cases at an equal distance from the upper surface of the fluid. This corollary holds also in the case mentioned in Cor. 1.

Fig. 2.

Let AB be the vessel containing the fluid, its velocity when issuing from the aperture $m n$ will be that which is due to the height $D m$, or equal to that which a heavy body would acquire by falling through that height. Because the orifice $m n$ is infinitely small, the velocity of the laminæ into which the fluid may be supposed to be divided, will also be infinitely small (art. 138.). But since all the fluid particles, by virtue of their gravity, have a tendency to descend with the same velocity; and since the different laminæ of the fluid lose this velocity, the column $m n s t$ must be pressed by the superincumbent column $D m n$; and calling S the specific gravity of the fluid, the moving force which pushes out the column $m n s t$ will be $S \times D m \times m n$ (art. 42.). Now let us suppose, that, when this moving force is pushing out the column $m n s t$, the absolute weight of the column $m n o p$, which may be represented by $S \times m n \times n p$, causes itself to fall through the height $n p$. Thus, if V, U be the velocities impressed upon the columns $m n s t$, and $m n o p$, by the moving forces $S \times D m \times m n$, and $S \times m n \times n p$; these moving forces must be proportional to their effects, or to the quantities of motion which they produce, that is, to $V \times m n s t$ and $U \times m n o p$, because the quantity of motion is equal to the velocity and mass conjointly; hence we shall have $S \times D m \times m n^2 : S \times m n \times n p = V \times m n s t : U \times m n o p$. But since the volumes $m n s t, m n o p$ are to one another as their heights $m o, o s$, and as their heights are run through in equal times, and consequently represent the velocity of their motion, $m n s t$ may be represented by $V \times m n$ and $m n o p$ by $U \times m n$; therefore we shall have $S \times D m \times m n : S \times m n \times n p = V \times V \times m n : U \times U \times m n$, and dividing by $m n, S \times D m : n p = V^2 : U^2$. Now let v be the velocity due to the height $D m$, then (see MECHANICS) $n p : U^2 = D m : v^2$; but since $S \times D m : S \times n p = V^2 : U^2$; then by (Euclid V. 15.), and by permutation $D m : V^2 = n p : U^2$, therefore by substitution (Euclid V. 11.) $D m : V^2 = D m : v^2$, and (Euclid V. 9.) $V^2 = v^2$ or $V = v$. But V is the velocity with which the fluid issues from the orifice $m n$, and v is the velocity due to the height $D m$; therefore, since the velocities are equal, the proposition is demonstrated.

146. COR. 4. When the fluid issues vertically, it will rise to a height equal to the perpendicular distance of the orifice from the surface of the fluid; for (see MECHANICS), this is true of falling bodies in general, and must therefore be true in the case of water: owing to the resistance of the air, however, and the friction of the issuing fluid upon the sides of the orifice, jets of water do not exactly rise to this height.

147. COR. 5. As the velocities of falling bodies are as the square roots of the heights through which they fall (see MECHANICS), the velocity V of the effluent water when the surface is at E , will be to its velocity v when the surface is at G , as $\sqrt{E n} : \sqrt{G n}$, (Cor. 1.) that is, the velocities of fluids issuing from a very small orifice are as the square roots of the altitude of the water above these orifices. As the quantities of fluids discharged are as the velocities, they will also be as the square roots of the altitude of the fluid. This corollary holds true of fluids of different specific gravities, notwithstanding Belidor (*Architec. Hydraul.* tom. i. p. 187.) has maintained the contrary; for though a column of mercury $D m n$ presses with 14 times the force of a similar column of water, yet the column $m n o p$ of mercury which is pushed out is also 14 times as heavy as a similar column of water; and as the resistance bears the same proportion to the moving force, the velocities must be equal.

Fig. 2.

148. COR. 6. When a vessel is emptying itself, if the area of the laminæ into which we may suppose it divided; be everywhere the same, the velocity with which the surface of the fluid descends, and also the velocity of efflux, will be uniformly retarded. For (art. 138.) as the velocity V with which the surface descends is to the velocity v at the orifice, as the area a of the orifice to the area A of the surface, then $V : v = a : A$; but the ratio of $a : A$ is constant, therefore V varies as v , that is, $V : V' = v : v'$; but, (Cor. 1.) $v : v' = \sqrt{h} : \sqrt{h'}$, h being the height of the surface above the orifice, therefore $V : V' = \sqrt{h} : \sqrt{h'}$. But this is the property of a body projected vertically from the earth's surface, and as the retarding force is uniform in the one case (see MECHANICS), it must also be uniform in the other.

143. COR. 1. If the vessel AB empties itself by the small orifice $m n$, so that the surface of the fluid takes successively the positions DP, QR, ST , the velocities with which the water will issue when the surfaces have

149. COR. 7. If a cylindrical vessel be kept constantly full, twice the quantity contained in the vessel will run out during the time in which the vessel would have emptied,

Motion of tied itself. For (Cor. 2. and 6.) the space through which Fluids, &c. the surface of the fluid at D would descend if its velocity continued uniform being $2Dm$, double of Dm the space which it actually describes in the time it empties itself, the quantity discharged in the former case will also be double the quantity discharged in the latter: because the quantity discharged when the vessel is kept full, may be measured by what the descent of the surface would be, if it could descend with its first velocity.

Fig. 2.

SCHOLIUM.

150. The reader will probably be surprised when he finds in some of our elementary works on hydrostatics, that the velocity of the water at the orifice is only equal to that which a heavy body would acquire by falling through *half* the height of the fluid above the orifice. This was first maintained by Sir Isaac Newton, who found that the diameter of the *vena contracta* was to that of the orifice as 21 to 25. The area therefore of the one was to the area of the other as 21^2 to 25^2 , which is nearly the ratio of 1 to $\sqrt{1}$. But by measuring the quantity of water discharged in a given time, and also the area of the *vena contracta*, Sir Isaac found that the velocity at the *vena contracta* was that which was due to the *whole* altitude of the fluid above the orifice. He therefore concluded, that since the velocity at the orifice was to that at the *vena contracta* as (H) $1 : \sqrt{1}$, and in the latter velocity was that which was due to the whole altitude of the fluid, the former velocity, or that at the orifice, must be that which is due to only *half* that altitude, the velocities being as the square roots of the heights. Now the difference between this theory and that contained in the preceding proposition may be thus reconciled. The velocity found by the preceding proposition is evidently the vertical velocity of the filaments at E, which being immediately above the centre of the aperture mn are not diverted from their course, and have therefore their vertical equal to their absolute velocity. But the vertical velocity of the particles between C and E, and E and D, is much less than their absolute velocity, on account of the obliquity of their motion, and also on account of their friction on the sides of the orifice. The mean vertical velocity, consequently, of the issuing fluid will be much less than the vertical velocity of the particles at E, that is, than the velocity found by the above proposition, or that due to the height Dm . Now the velocity found by Sir Isaac Newton from measuring the quantity of water discharged, was evidently the mean velocity, which ought to be less than the velocity given by the preceding proposition, the two velocities being as $1 : \sqrt{1}$ or as $1 : 1.414$. The theorem of Newton therefore may be considered as giving the mean velocity at the orifice, while our proposition gives the velocity of the particles at D, or the velocity at the *vena contracta*.

Fig. 1.

(H) When a fluid runs through a conical tube kept continually full, the velocities of the fluid in different sections will be inversely as the area of the sections. For as the same quantity of fluid runs through every section in the same time, it is evident that the velocity must be greater in a smaller section, and as much greater as the section is smaller, otherwise the same quantity of water would not pass through each section in the same time. Now the area of the *vena contracta* is to the area of the orifice, as $1 : \sqrt{1}$, therefore the velocity at the *vena contracta* must be to the velocity at the orifice as $\sqrt{2} : 1$.

PROP. II.

151. To find the quantity of water discharged from a very small orifice in the side or bottom of a reservoir, the time of discharge, and the altitude of the fluid, the vessel being kept constantly full, and any two of these quantities being given.

Motion Fluids, I

Plate CCLXV fig. 2.

Let A be the area of the orifice mn ; W the quantity of water discharged in the time T; H the constant height Dm of the water in the vessel, and let 16.087 feet be the height through which a heavy body descends in a second of time. Now, as the times of description are proportional to the square roots of the heights described, the time in which a heavy body will fall through the height H, will be found from the following analogy, $\sqrt{16.087} : \sqrt{H} = 1 : \frac{\sqrt{H}}{16.087}$, the time required. But as the velocity at the orifice is uniform, a column of fluid whose base is mn and altitude $2H$ (Prop. I. Cor. 2.) will issue in the time $16.087 \sqrt{H}$, or since A is the area of the orifice mn , $A \times 2H$ or $2HA$ will represent the column of fluid discharged in that time. Now since the quantities of fluid discharged in different times must be as the times of discharge, the velocity at the

orifice being always the same, we shall have $\frac{\sqrt{H}}{16.087} : T = 2HA : W$, and (GEOMETRY, Sect. IV. Theor. VIII.)

$$\frac{W\sqrt{H}}{16.087} = 2HAT \text{ or } W = \frac{2HAT \times 16.087}{\sqrt{H}}, \text{ and since } \frac{H}{\sqrt{H}} = \sqrt{H} \text{ we shall have } W = 2AT \sqrt{H} \times 16.087,$$

an equation from which we deduce the following formulae, which determine the quantity of water discharged, the time of discharge, the altitude of the fluid, and the area of the orifice, any three of these four quantities being given :

$$W = 2AT \sqrt{H} \times 16.087 \quad A = \frac{W}{2T \sqrt{H} \times 16.087}$$

$$H = \frac{W^2}{4A^2 T^2 \times 16.887} \quad T = \frac{W}{2A \sqrt{H} \times 16.087}$$

152. It is supposed in the preceding proposition that the orifice in the side of the vessel is so small that every part of it is equally distant from the surface of the fluid. But when the orifice is large like M (fig. 3.), the depths of different parts of the orifice below the surface of the fluid are very different, and consequently the preceding formulae will not give very accurate results.

Fig. 3.

Motion of Fluids, &c. sults. If we suppose the orifice M divided into a number of smaller orifices *a, b, c*, it is evident that the water will issue at *a*, with a velocity due to the height *D a*, the water at *b*, with a velocity due to the height *E b*, and the water at *c*, with a velocity due to the height *F c*. When the whole orifice, therefore, is opened, the fluid will issue with different velocities at different parts of its section. Consequently, in order to find new formulæ expressing the quantity of water discharged, we must conceive the orifice to be divided into an infinite number of areas or portions by horizontal planes; and by considering each area as an orifice, and finding the quantity which it will discharge in a given time, the sum of all these quantities will be the quantity discharged by the whole orifice M.

PROP. III.

153. To find the quantity of water discharged by a rectangular orifice in the side of a vessel kept constantly full.

Plate CCLXVII. Let ABD be the vessel with the rectangular orifice GL, and let AB be the surface of the fluid. Draw the lines MNOP, *m n o p* infinitely near each other, and from any point D draw the perpendicular DC meeting the surface of the fluid in C. Then regarding the infinitely small rectangle MO *m o* as an orifice whose depth below the surface of the fluid is H, we shall have by the first of the preceding formulæ, the quantity of water discharged in the time T, or $W = T \sqrt{16.087} \times \sqrt{CN} \times 2MO \times Nn$, CN being equal to H and MO $\times Nn$ to the area. As the preceding formula represents the quantity of fluid discharged by each elementary rectangular orifice, into which the whole orifice GL is supposed to be divided, we must find the sum of all the quantities discharged in the time T, in order to have the total quantity afforded by the finite orifice in the same time. Upon DC as the principal axis, describe the parabola CHE, having its parameter P equal to 4DC. Continue FG and DK to H and E. The area NP *p n* may be expressed by NP $\times Nn$. But (CONIC SECTIONS, Part I. Prop. X.) $NP^2 = CN \times P$ (P being the parameter of the parabola) therefore NP = $\sqrt{CN \times P}$, and multiplying by N *n* we have NP $\times Nn = Nn \sqrt{CN \times P}$, which expresses the area NP *p n*. Now this expression of the elementary area being multiplied by the constant quantity $T \sqrt{16.087} \times \frac{MO}{\sqrt{\frac{1}{2}P}}$ gives for a product $T \sqrt{16.087} \times \sqrt{CN} \times 2MO \times Nn$, for $\sqrt{\frac{1}{2}P} = \frac{1}{2}\sqrt{P}$ and $\frac{MO \times \sqrt{P}}{\frac{1}{2}\sqrt{P}} = 2MO$. But that product is the very same formula which expresses the quantity of water discharged in the time T by the orifice MO *o m*. Therefore since the elementary area MP *p m* multiplied by the constant quantity $T \sqrt{16.087} \times \frac{MO}{\sqrt{\frac{1}{2}P}}$ gives the quantity of water discharged by the orifice MO *o m* in a given time, and since the same may be proved of every other orifice of the same kind into which the whole orifice is supposed divided, we may conclude that the quantity of water discharged by

VOL. X. Part II. †

the whole orifice GL will be found by multiplying the parabolic area FHED by the same constant quantity $T \sqrt{16.087} \times \frac{MO}{\sqrt{\frac{1}{2}P}}$. Now the area FHED is equal to the difference between the areas CDE and CFH. But (CONIC SECTIONS, Part I. Prop. X.) the area CDE = $\frac{1}{2}CD \times DE$; and since $P = 4CD$, and (CONIC SECTIONS, Part I. Prop. X.) $DE^2 = CD \times P$ we have $DE^2 = CD \times 4CD = 4CD^2$, that is $DE = 2CD$, then by substituting this value of DE in the expression of the area CDE, we have $CDE = \frac{1}{2}CD^2$. The area CFH = $\frac{1}{2}CF \times FH$, consequently the area FHED = $\frac{1}{2}CD^2 - \frac{1}{2}CF \times FH$, which multiplied by the constant quantity, gives for the quantity of water discharged, ($\frac{1}{2}P^2$ being substituted instead of its equal $\frac{1}{2}CD^2$).

$$W = \frac{T \sqrt{16.087} \times MO \times \frac{1}{2}P^2 - \frac{1}{2}CF \times FH}{\sqrt{\frac{1}{2}P}}$$

But by the property of the parabola $FH^2 = CF \times P$ and $FH = \sqrt{CF \times P}$, therefore substituting this value of FH in the preceding formula, and also $\frac{1}{2}\sqrt{P}$ for its equal $\sqrt{\frac{1}{2}P}$, we have

$$W = \frac{T \sqrt{16.087} \times MO \times \frac{1}{2}P^2 - \frac{1}{2}CF \times \sqrt{CF \times P}}{\frac{1}{2}\sqrt{P}}$$

and dividing by $\frac{1}{2}\sqrt{P}$ gives us

$$W = T \sqrt{16.087} \times MO \times \frac{1}{2}P \sqrt{P} - \frac{1}{2}CF \times \sqrt{CF};$$

hence

$$T = \frac{W}{\sqrt{16.087} \times MO \times \frac{1}{2}P \sqrt{P} - \frac{1}{2}CF \times \sqrt{CF}};$$

$$MO = \frac{W}{T \sqrt{16.087} \times \frac{1}{2}P \sqrt{P} - \frac{1}{2}CF \times \sqrt{CF}};$$

$$P = \frac{9W}{4T \sqrt{16.087}} + 3CF \sqrt{CF} \Big| \frac{1}{2};$$

and since $P = 4CD$

$$CD = \frac{9W}{16T \sqrt{16.087}} + 12CF \times \sqrt{CF} \Big| \frac{1}{2}$$

$$CF = \frac{9W}{16T \sqrt{16.087}} + \frac{1}{2}P \sqrt{P} \Big| \frac{1}{2}$$

In these formulæ W represents the quantity of water discharged, T the time of discharge, MO the horizontal width of the rectangular orifice, P the parameter of the parabola = 4CD, CD the depth of the water in the vessel or the altitude of the water above the bottom of the orifice, and CF the altitude of the water above the top of the orifice. The vertical breadth of the orifice is equal to CD - CF.

154. Let *x* be the mean height of the fluid above the orifice, or the height due to a velocity, which, if communicated to all the particles of the issuing fluid, would make the same quantity of water issue in the time T as if all the particles moved with the different velocities due to their different depths below the surface, then by Prop. II. the quantity discharged or $W = 2T \times MO \times CD - CF \times \sqrt{x \times 16.087}$, the area of the orifice being MO

Motion of Fluids, &c.

× CD - CF, and by making this value of W equal to its value in the preceding article, we have the following equation.

$2T \times MO \times \sqrt{CD - CF} \times \sqrt{x \times 16.087} = T \sqrt{16.087} \times MO \times \frac{1}{2} \sqrt{P - \frac{1}{2} CF} \sqrt{CF}$, which by division and reduction, and the substitution of $\frac{1}{2}P$ instead of CD its equal, becomes

$$x = \frac{\frac{1}{2}(P \sqrt{P - \frac{1}{2}CF} \sqrt{CF})^2}{4(\frac{1}{2}P - CF)^2}$$

Now this value of x is evidently different from the distance of the centre of gravity of the orifice from the surface of the fluid, for this distance is $\frac{CD + CF}{2}$ or $\frac{\frac{1}{2}P + CF}{2}$. But in proportion as CE increases, the other qualities remaining the same, the value of x will approach nearer the distance of the centre of gravity of the orifice from the surface of the fluid; for when CF becomes infinite, the parabolic arch CHE will become a straight line, and consequently the mean ordinate of the curve, which is represented by the mean velocity of the water, will pass through the middle of FD or the centre of gravity of the orifice.

PROP. IV.

155. To find the time in which a quantity of fluid equal to ABRT, will issue out of a small orifice in the side or bottom of the vessel AB, that is, the time in which the surface AB will descend to RT.

Plate CCLXVII. fig. 5.

Draw DE, de at an infinitely small distance and parallel to AB. The lamina of fluid D de E may be represented by $DE \times ob$; DE expressing the area of the surface. When the surface of the water has descended to DE, the quantity of fluid which will be discharged by a uniform velocity in the time T, will be $T \sqrt{16.087} \times 2A \times \sqrt{om}$, A being the area of the orifice, as in Prop. II. But as the variation in the velocity of the water will be infinitely small, when the surface descends from DE to de , its velocity may be regarded as uniform. The time, therefore, in which the surface describes the small height ob will be found by the following analogy; $T \sqrt{16.087} \times 2A \times \sqrt{om} : T = DE \times ob : \frac{DE \times ob}{\sqrt{16.087} \times 2A \times \sqrt{om}}$. Now as this

formula expresses the time in which the surface descends from DE to de , and as the same may be shewn of every other elementary portion of the height CS, the sum of all these elementary times will give us the value of T, the time in which the surface AB falls down to RT. For this purpose, draw GP equal and parallel to Cn, and upon it as an axis, describe the parabola PVQ, having its parameter P equal to 4GP. Continue the lines AB, DE, de , RT, so as to form the ordinates HF, hf , UV, of the parabola. Upon GP as an axis describe a second curve, so that the ordinate GM may be equal to the area of the surface at AB, divided by the corresponding ordinate GQ of the parabola, and that the ordinate H may be the quotient

Motion of Fluids, &c.

of the area of the surface at DE divided by the ordinate HF. Now (CONIC SECTIONS, Part I. Prop. X.) $\frac{HF^2}{HP} = \frac{HP \times P}{HP} = P$, or $HF = \sqrt{HP \times P}$, that is $\sqrt{HP} \times \sqrt{P}$; and since $om = HP$; $\frac{DE}{\sqrt{om}} = \frac{DE \times \sqrt{P}}{HF}$. But

by the construction of the curve MN, we have $\frac{DE}{HF} = Hr$, consequently $\frac{DE}{\sqrt{om}} = Hr \times \sqrt{P}$. The elementary time therefore, expressed by $\frac{DE \times ob}{\sqrt{16.087} \times 2A \times \sqrt{om}}$

will, by the different substitutions now mentioned, be $\frac{Hr \times ob \times \sqrt{P}}{2A \sqrt{16.087}}$ or $\frac{\sqrt{P}}{2A \sqrt{16.087}} \times Hr \times ob$. But the factor $\frac{\sqrt{P}}{2A \sqrt{16.087}}$ consisting of constant quantities is

itself constant, and the other factor $Hr \times ob$ represents the variable curvilinear area $Hrsb$. Now as the same may be shown of every other element of the time T, compared with the corresponding elements of the area GU t M, it follows that the time T required, will be found by multiplying the constant quantity $\frac{\sqrt{P}}{2A \sqrt{16.087}}$ by the curvilinear area GU t M; therefore $T = \frac{\sqrt{P}}{\sqrt{16.087}} \times \frac{GU \ t \ M}{2A}$, and the time in which

the surface descends to mn , or in which the vessel empties itself, will be equal to $\frac{\sqrt{P}}{\sqrt{16.087}} \times \frac{GPNM}{2A}$.

COR. The quantity of fluid discharged in the given time T may be found by measuring the contents of the vessel AB between the planes AB, and RT, the descent of the surface AB, viz. the depth CS, being known.

PROP. V.

156. To find the time in which a quantity of fluid equal to ABRT will issue out of a small orifice in the side or bottom of the cylindrical vessel AB, that is, the time in which the surface AB will descend to RT.

Let us suppose that a body ascends through the height mC with a velocity increasing in the same manner as if the vessel AB were inverted, and the body fell from m to C. The velocity of the ascending body at different points of its path being proportional to the square roots of the heights described, will be expressed by the ordinates of the parabola PVQ. The line DE being infinitely near to de , as soon as the body arrives at b it will describe the small space bo or hH in a portion of time infinitely small, with a velocity represented by the ordinate HF. Now the time in which the body will ascend through the space mC or its

Plate CCLXVIII. fig. 6.

equal PG will be $\frac{\sqrt{PG}}{\sqrt{16.087}}$, because $\sqrt{16.087} : \sqrt{PG} = \sqrt{PG} : PG$ (See MECHANICS); and if the velocity

Motion of impressed upon the body when at C were continued uniformly, it would run through a space equal

the latter $\frac{DE}{HF}$ instead of Hr , which is equal to it by Motion of Fluids, &c.

to 2 GP or GQ in the time $\frac{\sqrt{PG}}{\sqrt{16.087}}$. But (DYNAMICS, 22.) the times of description are as the spaces described directly, and the velocities inversely, and therefore the time of describing the space 2 GP or GQ uniformly, viz. the time $\frac{\sqrt{PG}}{\sqrt{16.087}}$ will be to the time

construction, will become $\frac{\sqrt{P}}{\sqrt{16.087}} \times \frac{Hh}{HF} : \frac{\sqrt{P}}{\sqrt{16.087}}$

of describing the space hH uniformly, as, $\frac{GQ}{GQ} : \frac{Hh}{HF}$

$\times \frac{DE \times Hh}{A \times HF}$, DE representing, in this and in the following proposition, the area of the surface of the fluid at D. Now, if we multiply the first of these expressions by DE, and the second by A, we shall find the two products equal; consequently (Euclid VI. 16.) the first expression is to the second, or the time of the body's ascent through hH is to the time of the surface's descent through Hh , as the area A of the orifice is to the area DE of the base of the cylindrical vessel; and as the same may be demonstrated of every elementary time in which the ascending body and the descending surface describe equal spaces, it follows that the whole time in which the ascending body will describe the height mC or PG, is to the whole time in which the surface AB will descend to mn , or in which the vessel will empty itself, as the area A of the orifice is to the

that is, as $\frac{GQ}{GQ}$ or 1 : $\frac{\sqrt{PG}}{\sqrt{16.087}} = \frac{Hh}{HF} : \frac{\sqrt{PG}}{\sqrt{16.087}}$

area of the surface DE, that is $A : DE = \frac{\sqrt{PG}}{\sqrt{16.087}}$

$\times \frac{Hh}{HF}$ the time in which the ascending body will describe Hh uniformly; but PG being equal to $\frac{1}{2}P$, the parameter of the parabola, we shall have $\sqrt{PG} = \sqrt{\frac{1}{2}P} = \frac{1}{\sqrt{2}}\sqrt{P}$. Substituting this value of \sqrt{PG} in the last formula, we shall have for the expression of the time of describing Hh uniformly $\frac{\frac{1}{\sqrt{2}}\sqrt{P}}{\sqrt{16.087}} \times \frac{Hh}{HF}$

But by Prop. IV. the time in which the surface DH descends into the position dh , that is, in which it describes Hh , is represented by $\frac{\sqrt{P}}{2A\sqrt{16.087}} \times Hr \times ob$ or

$\frac{\sqrt{PG}}{\sqrt{16.087}} \times \frac{DE}{A}$, the time in which the vessel AB will empty itself. If RT mn be the vessel, it may be shewn in the same manner, that the time in which it will empty itself will be $\frac{\sqrt{PU}}{\sqrt{16.087}}$

$\frac{\sqrt{P}}{\sqrt{16.087}} \times \frac{Hr \times Hh}{2A}$. Therefore the time in which the ascending body moves through hH , is to the time in which the descending surface moves through Hh as $\frac{\frac{1}{\sqrt{2}}\sqrt{P}}{\sqrt{16.087}}$

$\times \frac{DE}{A}$, DE being equal to RT. But the difference between the time in which the vessel AB mn empties itself, and the time in which the vessel RT mn empties itself, will be equal to the time required in the proposition, during which the surface AB descends to RT. This time therefore will be

$\times \frac{Hh}{HF} : \frac{\sqrt{P}}{\sqrt{16.087}} \times \frac{Hr \times Hh}{2A}$, which expressions after being multiplied by 2, and after substituting in

$$T = \frac{\sqrt{PG}}{\sqrt{16.087}} \times \frac{DE}{A} \sqrt{\frac{PU}{16.087}} \times \frac{DE}{A} = \frac{DE \sqrt{PG} - DE \sqrt{PU}}{A \sqrt{16.087}}$$

$$T = \frac{DE \times \sqrt{PG} - \sqrt{PU}}{A \sqrt{16.087}} \text{ Hence}$$

$$PU = \left(\frac{T, A \sqrt{16.087}}{DE} - \sqrt{PG} \right)^2$$

$$PG = \left(\frac{T, A \sqrt{16.087}}{DE} + \sqrt{PU} \right)^2$$

$$PG - PU \text{ or } UG = \frac{2T, A \times DE \sqrt{PG \times 16.087} - T^2 A^2 \times 16.087}{DE^2}$$

As the quantity of fluid discharged while the surface AB descends to RT is equal to $DE \times UG$, we shall have

$$W = DE \times \frac{2T, A \times DE \sqrt{PG \times 16.087} - T^2 A^2 \times 16.087}{DE^2}$$

$$A = \frac{DE \times \sqrt{PG \times PU}}{T \sqrt{16.087}}$$

$$DE = \frac{T, A \sqrt{16.087}}{\sqrt{PG} - \sqrt{PU}}$$

Motion of Fluids, &c.

PROP. VI.

157. If two cylindrical vessels are filled with water, the time in which their surfaces will descend through similar heights will be in the compound ratio of their bases, and the difference between the square roots of the altitudes of each surface at the beginning and end of its motion, directly, and the area of the orifices inversely.

Figs. 6. and 7.

Let $AB\ m\ n$, $A'\ B'$, $m'\ n'$ be the two vessels; then, by the last proposition, the time T , in which the surface AC of the first descends to RT , will be to the time T' in which the surface $A'\ B'$ of the second descends to

$$R'T' \text{ as } \frac{DE \times \sqrt{PG} \times \sqrt{PU}}{A \sqrt{16.087}} \text{ to } \frac{D'E' \times \sqrt{P'G'} - \sqrt{P'U'}}{A' \sqrt{16.087}}$$

or, by dividing by $\sqrt{16.087}$, as $\frac{DE \times \sqrt{PG} - \sqrt{PU}}{A}$

to $\frac{D'E' \times \sqrt{P'G'} - \sqrt{P'U'}}{A}$. Q. E. D.

158. COR. Hence the time in which two cylindrical vessels full of water will empty themselves, will be in the compound ratio of their bases and the square roots of their altitudes directly, and the area of the orifices inversely; for in this time the surfaces $AB, A'\ B'$ descend to $m\ n, m'\ n'$ respectively, and therefore $\sqrt{PG} - \sqrt{PU} = \sqrt{PG}$;

Hours.	0	1	2	3	4	5	6	7	8	9	10	11	12
Distance of each Hour above the bottom.	144	121	100	81	64	49	36	25	16	9	4	1	0
Number of Parts in each Hour.	23	21	19	17	15	13	11	9	7	5	3	1	

For since the velocity with which the surface AB descends, the area of that surface being always the same, is as the square roots of its altitude above the orifice (PROP. I. COR. 6.); and since the velocities are as the times of description, the times will also be as the square roots of the altitudes, that is, when

12 11 10 9 &c. are the times
144 121 100 81 will be the altitudes of the surface. Q. E. D,

PROP. VIII.

160. To explain the lateral communication of motion in fluids.

Lateral communication of motion in fluids. Fig. 9.

This property of fluids in motion was discovered by M. Venturi, professor of natural philosophy in the university of Modena, who has illustrated it by a variety of experiments in his work on the lateral communication of motion in fluids. Let a pipe AC , about half an inch in diameter and a foot long, proceeding from the reservoir AB , and having its extremity bent into the form CD , be inserted into the vessel CDG , whose side DG gradually rises till it passes over the rim of the vessel. Fill this vessel with water, and pour the same fluid into the reservoir AB , till, running down the pipe AC , it forms the stream EGH . In a short while, the

since PU vanishes, the times will be as $\frac{DE \times \sqrt{PG}}{A}$ to $\frac{D'E' \times \sqrt{P'G'}}{A}$.

PROP. VII.

159. To explain the theory and construction of clepsydra or water-clocks. Theory of clepsydra or water-clocks.

A clepsydra or water-clock, is a machine which, filled with water, measures time by the descent of the fluid surface. See Part III. on Hydraulic Machinery.

It has already been demonstrated in Prop IV. that the times in which the surface AB descends to DE and RT , &c. are as the areas $GM\ r\ H$, $GM\ t\ U$, &c. If such a form therefore is given to the vessel that the areas $GM\ r\ H$, $GM\ t\ U$, &c. increase uniformly as the times, or are to one another as the numbers 1, 2, 3, 4, 5, &c. the time in which the surface AB descends to DE , and RT , &c. will be in the same ratio, and the vessel will form a machine for measuring time. If the vessel is cylindrical and empties itself in 12 hours, its altitude may be divided in such a manner that the fluid surface may take exactly an hour to descend through each division. Let the cylindrical vessel, for example, be divided into 144 equal parts, then the surface of the water, when the twelve hours begins to run, will be 144 parts above the bottom of the vessel; when one hour is completed, the surface will be 121 parts above the bottom, and so on in the following manner.

water in the vessel CDG will be carried off by the current EG , which communicates its motion to the adjacent fluid. In the same way, when a stream of water runs through air, it drags the air along with it, and produces wind. Hence we have the water blowing machine which conveys a blast to furnaces, and which shall be blowing described in a future part of this article. The lateral communication of motion, whether the surrounding fluid be air or water, is well illustrated by the following beautiful experiments of Venturi's. In the side of the reservoir AB insert the horizontal line P about an inch and a half in diameter, and five inches long. At the point o of this pipe, about seven-tenths of an inch from the reservoir, fasten the bent glass tube $o\ n\ m$, whose cavity communicates with that of the pipe, whilst its other extremity is immersed in coloured water contained in the small vessel F . When water is poured into the reservoir AB , having no connection with the pipe C , so that it may issue from the horizontal pipe, the red liquor will rise towards m in the incurvated tube $o\ n\ m$. If the descending leg of this glass syphon be six inches and a half longer than the other, the red liquor will rise to the very top of the syphon, enter the pipe P , and running out with the other water will in a short time leave the vessel F empty. Now the cause of this phenomenon is evidently this: When the water begins to flow from the pipe P , it communicates with the air in the syphon $o\ n\ m$, and drags

drag a portion along with it. The air in the syphon is therefore rarefied, and this process of rarefaction is constantly going on as long as the water runs through the horizontal pipe. The equilibrium between the external air pressing upon the fluid in the vessel F, and that included in the syphon, being thus destroyed, the red liquor will rise in the syphon, till it communicates with the issuing fluid, and is dragged along with it through the orifice of the pipe P, till the vessel F is emptied.

PROP. IX.

161. To find the horizontal distance to which fluids will spout from an orifice perforated in the side of a vessel, and the curve which it will describe.

Let AB be a vessel filled with water, and C an orifice in its side, so inclined to the horizon as to discharge the fluid in the direction CP. If the issuing fluid were influenced by no other force except that which impels it out of the orifice, it would move with an uniform motion in the direction CP. But immediately upon its exit from the orifice C it is subject to the force of gravity, and is therefore influenced by two forces, one of which impels it in the direction CP, and the other draws it downwards in vertical lines. Make CE equal to EG, and CP double of CS the altitude of the fluid. Draw PL parallel to CK and join SL. Draw also EF, GH parallel to CN, and FM, HN parallel to CG, and let CM, CN represent the force of gravity, or the spaces through which it would cause a portion of fluid to descend in the time that this portion would move through CE, CG respectively by virtue of the impulsive force. Now, it follows from the composition of forces, (DYNAMICS, 135.) that the fluid at C, being solicited in the direction CE by a force which would carry it through CE in the same time that the force of gravity would make it fall through CM, will describe the diagonal CF of the parallelogram CEFM, and will arrive at F in the same time that it would have reached E by its impulsive force, or M by the force of gravity; and for the same reason the portion of the fluid will arrive at H in the same time that it would have reached G by the one force, and N by the other. The fluid therefore being continually deflected from its rectilinear direction CP by the force of gravity, will describe a curve line CEHP, which will be a parabola: for since the motion along CP must be uniform, CE, CG will be to one another as the times in which they are described; and may therefore represent the times in which the fluid would arrive at E and G, if influenced by no other force. But in the time that the fluid has described CE gravity has made it fall through EF, and in the time that it would have described

CG, gravity has caused it to fall through GH. Now, since the spaces are as the squares of the times in which they are described, (DYNAMICS, 37. 2.) we shall have $EF : GH = CE^2 : CG^2$. But on account of the parallelograms CEFM, CGHN, EF and GH are equal to CM and CN respectively, and MF, NH to CE, CG respectively; therefore $CM : CN = MF^2 : NH^2$, which is the property of the parabola, CM, CN being the abscissæ, and ME, NH the ordinates (CONIC SECTIONS, Part I. Prop. IX. Cor.).

162. On account of the parallels LP, CX, LC, GX, the triangles LCP, GCX are similar, and therefore (GEOM. Sect. IV. Theor. XX.) $CG : CX = PC : PL$ and $GX : CX = CL : PL$. Hence $CG = \frac{CX \times PC}{PL}$, and $GX = \frac{CX \times CL}{PL}$, but since $PC = 2CS$, we have $CG = \frac{CX \times 2CS}{PL}$, and since $GX = GX - HX$, we shall have

$$GH = \frac{CX \times CL}{PL} - HX.$$

But as the parameter of the parabola CRK is equal to $4CS$ (1), we have, by the property of this conic section, $NH^2 = CN \times 4CS$, or $CG^2 = 4GH \times CS$; therefore, by substituting in this equation the preceding values of CG and GH, we shall have $CX^2 \times CS = CX \times CL \times PL - HX \times PL^2$. Now, it is evident, from this equation, that HX is nothing, or vanishes when $CX = 0$, or when $CX = \frac{CL \times PL}{CS}$, for HX being $= 0$, $HX \times PL^2$, will also be $= 0$, and the equation will become $CX^2 \times CS = CX \times CL \times PL$, or dividing by CX and CS, it becomes $CX = \frac{CL \times PL}{CS}$.

But when HX vanishes towards K, CX is equal to CK, consequently $CK = \frac{CL \times PL}{CS}$. Bisect CK in T, then $CT = \frac{CK}{2}$, and $CT = \frac{CL \times PL}{2CS}$. Draw TR perpendicular to CK, and TR will be found $= \frac{CL^2}{4CS}$.

Then if Hm be drawn at right angles to HX, we shall have $CX = CT - Hm = \frac{CL \times PL}{2CS} - Hm$ and $HX = RT - Rm = \frac{CL^2}{4CS} - Rm$. After substituting these values of CX and HX in the equation $CX^2 \times CS = CX \times CL \times PL - HX \times PL^2$, it will become, after the necessary reductions, $Hm^2 = \frac{PL^2}{CS} \times Rm$. The curve CRK

is

(1) The parameter of the parabola described by the issuing fluid, is equal to *four times* the altitude of the fluid above the orifice. For since the fluid issues at C with a velocity equal to that acquired by falling through SC, if this velocity were continued uniform, the fluid would move through $2CS$ or CP, in the same time that a heavy body would fall through SC. Draw PQ parallel to CS, and QW to CP; then since Q is in the parabola, the fluid will describe CP uniformly in the same time that it falls through CW by the force of gravity, therefore $CW = CS$. Now $CP = 2CS$, and $CP^2 = 4CS^2 = 4 \times CS \times CS = 4 \times CS \times CW$; but it is a property of the parabola, that the square of the ordinate WQ or CP is equal to the product of the abscissa CW and the parameter, therefore $4CS$ is the parameter of the parabola.

Motion of is therefore a parabola whose vertex is R, its axis
Fluids. &c.
RT and its parameter $\frac{PL^2}{CS}$, Rm being an abscissa of the

axis, and Hm its correspondent ordinate. Now, making $a=CS$, the altitude of the reservoir; R = radius; $m=PL$ the sine of the angle PCL; and $n=CL$, the cosine of the same angle, CP being radius. Then $CP:PL=R:m$, therefore $PL \times R=CP \times m$, and dividing by R and substituting $2a$ or $2CS$ instead of its equal CP, we have $PL=\frac{2am}{R}$, and by the very same reason-

ing, we have $CL=\frac{2an}{R}$. Hence $RT \times \frac{CL^2}{4CS}$ will be $=\frac{4a^2n^2}{R^2}$ divided by $4a$, or $RT=a \times \frac{n^2}{R^2}$, and $CT=\frac{CL \times PL}{2CS}=\frac{4a^2mn}{2a \times R^2}=2a \times \frac{mn}{R^2}$, and the parameter of the parabola $=\frac{PL^2}{CS}=\frac{4a^2m^2}{a \times R^2}=4a \times \frac{m^2}{R^2}$.

Fig. 2.

163. Hence we have the following construction. With $\frac{1}{2}CS$ as radius, describe the semicircle SGC, which the direction CR of the jet or issuing fluid meets in G. Draw GN perpendicular to CS, and having prolonged it towards R, make GR equal to GN. From R let fall RT perpendicular to CK and meeting it in T, and upon RT, CT describe the parabola CRK having its vertex in R, this parabola shall be the course of the issuing fluid. For by the construction NR or $CT=2GN$, and on account of the similar triangles SGC, CGN, SC:SG=CG:GN; hence $SC \times GN=SG \times CG$, or $2GN$, or $CT=\frac{2SG \times CG}{SC}$. But from the similarity of

triangles CS:CG=SG:GN and CS:CG=CG:CN, consequently, when CG is radius or =R, GN will be the sine m of the angle GCS, and CN its cosine n ; and we shall then have, by Euclid VI. 16. and reduction $SG=\frac{CS \times m}{R}$, and $CG=\frac{CS \times n}{R}$. But substituting these values of SG and CG in the equation $CT=\frac{2SG \times CG}{SC}$, we have $CT=\frac{2}{SC} \times \frac{CS \times m}{R} \times \frac{CS \times n}{R}=\frac{2CS \times m \times CS \times n}{CS \times R \times R}=\frac{2CS \times mn}{R^2}=2a \times \frac{mn}{R^2}$. But the

parameter P of the parabola CRK is equal to $\frac{CT^2}{RT}$, because it is a third proportional to the abscissa and its ordinate, therefore $P=\frac{4a^2 \times m^2 n^2}{R^2 \times RT}$. Now $RT=CN$, and $CN=\frac{NG \times n}{m}$, because $CN:NG=m:n$, or $CN=RT=a \times \frac{n^2}{R^2}$ by substituting the preceding value of NG.

Therefore the parameter $P=(\frac{4a^2 \times m^2 n^2}{R^2} \div (\frac{a \times n^2}{R^2}))=4a \times \frac{m^2}{R^2}$, which is the same value of the parameter as was found in the preceding article, and therefore verifies the construction.

164. COR. 1. Since $NG=GR$ and $CT=TK$, the am-

plitude or distance CK, to which the fluid will reach on a horizontal plane, will be $4NG$, or quadruple the sine of the angle formed by the direction of the jet and a vertical line, the chord of the arch CG being radius.

165. COR. 2. If Sr be made equal to CN, and rg be drawn parallel to CT, and gr be made equal to ng ; then if the direction of the jet be Cg , the fluid will describe the parabola CrK whose vertex is r , and will meet the horizontal line in K, because $rg=NG$, and $4ng=4NG=CK$. The same may be shewn of every other pair of parabolas whose vertices Rr are equidistant from ac a horizontal line passing through the centre of the circle.

166. COR. 3. Draw the ordinate ab through the centre a , and since this is the greatest ordinate that can be drawn, the distance to which the water will spout, being equal to $4a$, will be the greatest when its line of direction passes through b , that is, when it makes an angle of 45° with the horizon.

167. COR. 4. If an orifice be made in the vessel AB at N, and the water issues horizontally in the direction NG, it will describe the parabola NT, and CT will be equal to $2NG$. For (by Prop. IX. note) the parameter of the parabola NT is equal to $4NS$, and by the property of the parabola $CT^2=NC \times 4NS$, or $\frac{1}{2}CT=2\sqrt{NC \times NS}$; but by the property of the circle (GEOM. Sect. IV. Theor. XXVIII.) $NG^2=NC \times NS$, and $NG=\sqrt{NC \times NS}$, hence $CT=2NG$. If the fluid is discharged from the orifice at n , so that $Sn=CN$, ng will be =NG, and it will spout to the same distance CT.

PROP. X.

168. To determine the pressure exerted upon pipes by the water which flows through them.

Let us suppose the column of fluid CD divided into an infinite number of laminae EFfe. Then friction being abstracted, every particle of each lamina will move with the same velocity when the pipe CD is horizontal. Now the velocity at the vena contracta mn may be expressed by \sqrt{A} , A being the altitude of the fluid in the reservoir. But the velocity at the vena contracta is to the velocity in the pipe, as the area of the latter is to the area of the former. Therefore d being the diameter of the vena contracta, and d' that of the pipe CD, the area of the one will be to the area of the other, as $d^2 : d'^2$, (GEOMETRY, Sect. VI. Prop. IV.) consequently we shall have $d' : d = \sqrt{A} : \frac{d' \sqrt{A}}{d}$, the velocity of the water in the pipe. But since the velocity \sqrt{A} is due to the altitude A, the velocity $\frac{d' \sqrt{A}}{d}$ will be due to the altitude $\frac{d'A}{d^2}$. Now as each particle of fluid which successively reaches the extremity DH of the pipe, has a tendency to move with the velocity \sqrt{A} , while it moves only with the velocity $\frac{d' \sqrt{A}}{d}$, the extremity Dn of the pipe will sustain a pressure equal to the difference of the pressures produced by the velocities \sqrt{A} and $\frac{d' \sqrt{A}}{d}$, that is,

by

Experiments on the Motion of Fluids.

by a pressure $A - \frac{\rho A}{d^4}$, A representing the pressure which produces the velocity \sqrt{A} , and $\frac{\rho A}{d^4}$ the pressure which produces the velocity $\frac{\rho^2 \sqrt{A}}{d^2}$. But this pressure is distributed through every part of the pipe CD, consequently the pressure sustained by the sides of the pipe will be $A - \frac{\rho A}{d^4}$.

169. COR. 1. If a very small aperture be made in the side of the pipe, the water will issue with a velocity due to the height $A - \frac{\rho A}{d^4}$. When the diameter ρ of the orifice is equal to the diameter d of the pipe, the altitude becomes $A - A$ or nothing; and if the orifice is in this case below the pipe, the water will descend through it by drops. Hence we see the mistake of those who have maintained, that when a lateral orifice is pierced in the side of a pipe, the water will rise to a height due to the velocity of the included water.

170. COR. 2. Since the quantities of water, discharged by the same orifice, are proportional to the square roots of the altitudes of the reservoir, or to the pressures exerted at the orifice, the quantity of water discharged by a lateral orifice may be easily found. Let W be the quantity of water discharged in a given time by the proposed aperture under the pressure A , and let w be the quantity discharged under the pressure $A - \frac{\rho A}{d^4}$. Then $W :$

$$w = \sqrt{A - \frac{\rho A}{d^4}} : \sqrt{A} :: W : w$$

$$\text{consequently, } w \times \sqrt{A} = W \times \sqrt{A - \frac{\rho A}{d^4}}$$

$$\text{and } w = \frac{W \times \sqrt{A - \frac{\rho A}{d^4}}}{\sqrt{A}} = W \sqrt{\frac{d^4 - \rho^2}{d^4}}$$

Therefore, since W may be determined by the experiments in the following chapter, w is known.

CHAP. II. Account of Experiments on the Motion of Water discharged from vessels, either by Orifices or additional Tubes, or running in Pipes or open Canals.

Ratio between the area of the vena contracta and the orifice.

171. IN the preceding chapter, we have taken notice of the contraction produced upon the vein of fluid issuing from an orifice in a tin plate, and have endeavoured to ascertain its cause. According to Sir Isaac Newton, the diameter of the *vena contracta* is to that of the orifice as 21 to 25. *Polenus* makes it as 11 to 13; *Bernoulli* as 5 to 7; the *Chevalier de Buat* as 6 to 7; *Bossut* as 41 to 50; *Michelotti*, as 4 to 5; and *Venturi*, as 4 to 5. This ratio, however, is by no means constant. It varies with the form and position of the orifice, with the thickness of the plate in which the orifice is made, and likewise with the form of the vessel and the weight of the superincumbent fluid. But these variations are too trifling to be regarded in practice.—We shall now lay before the reader an account of the results of the experiments of different philosophers, but particularly those of the Abbé Bossut, to whom the science is deeply indebted both for the accuracy and extent of his labours.

SECT. I. On the Quantity of Water discharged from Vessels constantly full by Orifices in thin Plates.

Experiments on the Motion of Fluids.

172. In the following experiments, which were frequently repeated in various ways, the orifice was pierced in a plate of copper about half a line thick. When the orifice is in the bottom of the vessel, it is called a *horizontal* orifice, and when it is in the side of it, it is called a *lateral* orifice.

TABLE I. Shewing the Quantity of Water discharged in one minute, by orifices differing in form and position.

Altitude of the fluid above the centre of the orifice.	Form and position of the orifice.	The orifice's diameter.	No of cub. in. discharged in a minute.
ft. in. Lin.	Circular and Horizontal	6 lines	2311
11 8 10	Circular and Horizontal	1 inch	9281
	Circular and Horizontal	2 inches	37203
	Rectangular and Horizontal	1 inch by 3 lines	2933
	Horizontal and Square	1 inch, side	11817
9 0 0	Horizontal and Square	2 inch, side	47361
	Lateral and Circular	6 lines	2018
	Lateral and Circular	1 inch	8135
4 0 0	Lateral and Circular	6 lines	1353
	Lateral and Circular	1 inch	5436
5 0 7	Lateral and Circular	1 inch	628

173. From the results contained in the preceding table, we may draw the following conclusions.

1. That the quantities of water discharged in equal times by different apertures, the altitudes of the fluid being the same, are very nearly as the areas of the orifices. That is, if A or a represent the areas of the orifices, and W , w the quantities of water discharged,

$$W : w = A : a.$$

2. The quantities discharged in equal times by the same aperture, the altitude of the fluid being different, are to one another very nearly as the square roots of the altitudes of the water in the reservoir, reckoning from the centres of the orifices. That is, if H , h be the different altitudes of the fluid, we shall have $W : w = \sqrt{H} : \sqrt{h}$.

3. Hence we may conclude in general that the quantities discharged in the same time by different apertures, and under different altitudes in the reservoir, are in the compound ratio of the areas of the orifices, and the square roots of the altitudes.—Thus, if W , w be the quantities discharged in the same time from the orifices A , a , under the same altitude of water; and if W' , w' be the quantities discharged in the same time by the same aperture a under different altitudes, H , h : then by the first of the two preceding articles.

$$W : w = A : a, \text{ and by the second}$$

$w : W = \sqrt{H} : \sqrt{h}$. Multiplying these analogies together, gives us

$$W w : W' w' = A \sqrt{H} : a \sqrt{h}, \text{ and dividing by } w.$$

$$W : W' = A \sqrt{H} : a \sqrt{h}.$$

Experiments on the Motion of Fluids.

This rule is sufficiently correct in practice; but when great accuracy is required, the following remarks must be attended to.

4. Small orifices discharge less water in proportion than great ones, the altitude of the fluid being the same. The circumference of the small orifices being greater in proportion to the issuing column of fluid than the circumferences of greater ones, the friction, which increases with the area of the rubbing surfaces, will also be greater, and will therefore diminish the velocity, and consequently the quantity discharged.

5. Hence of several orifices whose areas are equal, that which has the smallest circumference will discharge more water than the rest under the same altitude of fluid in the reservoir, because in this case the friction will be least.—Circular orifices, therefore, are the most advantageous of all, for the circumference of a circle is the shortest of all lines that can be employed to inclose a given space.

6. In consequence of a small increase which the contraction of the vein of fluid undergoes, in proportion as the altitude of the water in the reservoir augments, the quantity discharged ought also to diminish a little as that altitude increases.

By attending to the preceding observations, the results of theory may be so corrected, that the quantities of water discharged in a given time may be determined with the greatest accuracy possible.

Comparison between the theoretical and the real discharges from a circular orifice.

174. The abbé Bossut has given the following table containing a comparison of the theoretical with the real discharges, for an orifice one inch diameter, and for different altitudes of the fluid in the reservoir. The real discharges were not found immediately by experiment, but were determined by the precautions pointed out in the preceding articles, and may be regarded to be as accurate as if direct experiments had been employed. The fourth column was computed by M. Prony.

TABLE II. Comparison of the Theoretic with the Real discharges from an orifice one inch in diameter.

Constant altitude of the water in the reservoir above the centre of the orifice.	Theoretical discharges through a circular orifice one inch in diameter.	Real discharges in the same time through the same orifice.	Ratio of the theoretical to the real discharges.
Paris Feet.	Cubic Inches.	Cubic Inches.	
1	4381	2722	1 to 0.62133
2	6196	3846	1 to 0.62073
3	7589	4710	1 to 0.62064
4	8763	5436	1 to 0.62034
5	9797	6075	1 to 0.62010
6	10732	6654	1 to 0.62000
7	11592	7183	1 to 0.61965
8	12392	7672	1 to 0.61911
9	13144	8135	1 to 0.61892
10	13855	8574	1 to 0.61883
11	14530	8990	1 to 0.61873
12	15180	9384	1 to 0.61819
13	15797	9764	1 to 0.61810
14	16393	10130	1 to 0.61795
15	16968	10472	1 to 0.61726
1	2	3	4

175. It is evident from the preceding table, that the theoretical, as well as the real discharges, are nearly proportional to the square roots of the altitudes of the fluid in the reservoir. Thus, if we take the altitudes 1 and 4, whose square roots are as 1 to 2, the real discharges taken from the table are 2722, 5436, which are to one another very nearly as 1 to 2, their real ratio being as 1 to 1.997.

The fourth column of the preceding table also shows us that the theoretical are to the real discharges nearly in the ratio of 1 to 0.62, or more accurately, as 1 to 0.61938; therefore 0.62 is the number by which we must multiply the discharges as found by the formulæ in the preceding chapter, in order to have the quantities of water actually discharged.

176. In order to find the quantities of fluid discharged by orifices of different sizes, and under different altitudes of water in the reservoir, we must use the table in the following manner. Let it be required, for example, to find the quantity of water furnished by an orifice three inches in diameter, the altitude of the water in the reservoir being 30 feet. As the real discharges are in the compound ratio of the area of the orifices, and the square roots of the altitudes of the fluid, (art. 173. N^o 3.) and as the theoretical quantity of water discharged by an orifice one inch in diameter, is by the second column of the table 16918 cubic inches in a minute, we shall have this analogy, $1 \sqrt{15} : 9 \sqrt{30} = 16968 : 215961$ cubic inches, the quantity required. This quantity being diminished in the ratio of 1 to .62, being the ratio of the theoretical to the actual discharges, gives 133896 for the real quantity of water discharged by the given orifice. But (by N^o 5. of art. 173.) the quantity discharged ought to be a little greater than 133896, because greater orifices discharge more than small ones; and by N^o 6. the quantity ought to be less than 133896, because the altitude of the fluid is double that in the table. These two causes therefore having a tendency to increase and diminish the quantity deduced from the preceding table, we may regard 133896 as very near the truth. Had the orifice been less than one inch, or the altitude less than 15 feet, it would have been necessary to diminish the preceding answer by a few cubic inches. Since the velocities of the issuing fluid are as the quantities discharged, the preceding results may be employed also to find the real velocities from those which are deduced from theory.

177. As the velocity of falling bodies is 16.087 feet per second, the velocity due to 16.087 feet will be 32.174 feet per second, and as the velocities are as the square roots of the height, we shall have $\sqrt{16.087} : \sqrt{H} = 32.174 : V$ the velocity due to any other height, consequently $V = \frac{32.174 \sqrt{H}}{\sqrt{16.087}} = \frac{32.174 \sqrt{H}}{4.011} = 8.016 \sqrt{H}$,

so that 8.016 is the coefficient by which we must always multiply the altitude of the fluid in order to have its theoretical velocity.

178. According to the experiments of M. Eytelwein, published at Berlin in 1801, in his treatise *Handbuch der Mechanik und der Hydraulik*, the following are the ratios between the theoretical and actual discharges, and the coefficients by which the height may be multiplied in order to find the velocities of the issuing fluid.

Experiments on the Motion of Fluids.

Experiments on the Motion of Fluids.

TABLE III. Results of Eytelwein's Experiments.

No	Nature of the orifices employed.	Ratio between the theoretical and real discharges.	Coefficients for finding the velocities.
1	When the orifice has the form of the contracted stream	1 to 0.973	7.8
2	For wide openings whose bottom is on a level with that of the reservoir	1 to 0.961	7.7
3	For sluices with walls in a line with the orifice	1 to 0.961	7.7
4	For bridges with pointed piers	1 to 0.961	7.7
5	For narrow openings whose bottom is on a level with that of the reservoir	1 to 0.861	6.9
6	For smaller openings in a sluice with side walls	1 to 0.861	6.9
7	For abrupt projections and square piers of bridges	1 to 0.861	6.9
8	For openings in sluices without side walls	1 to 0.635	5.1
9	For orifices in a thin plate	1 to 0.625	5.0

179. M. Eytelwein has likewise shown, that the quantity of water discharged from rectangular orifices in the side of a reservoir extending to the surface, may be found by taking two-thirds of the velocity due to the mean height, and allowing for the contraction according to the form of the orifice.

SECT. II. On the Quantity of Water discharged from Vessels constantly full, by small Tubes adapted to Circular Orifices.

180. The difference between the natural discharges, and those deduced from theory, arises from the contraction of the fluid vein, and from the friction of the water against the circumference of the orifice. If the operation of any of these causes could be prevented, the quantities of water actually discharged would approach nearer the theoretical discharges. There is no probability of diminishing friction in the present case by the application of unguents; but if a short cylindrical tube be inserted in the orifice of the vessel, the water will follow the sides of the tube, the contraction of the fluid vein will be in a great measure prevented, and the actual discharges will approximate much nearer to those deduced from theory, than when the fluid issues through a simple orifice.

181. If a cylindrical tube two inches long, and two inches in diameter, be inserted in the reservoir, and if this orifice is stopped by a piston till the reservoir is filled with water, the fluid, when permitted to escape, will not follow the sides of the tube, that is, the tube will not be filled with water, and the contraction in the vein of fluid will take place in the same manner as if the orifice were pierced in a thin plate. When the cylindrical tube was one inch in diameter, and two inches long, the water followed the sides of the tube, and the vein of fluid ceased to contract. While M. Bossut was repeating this experiment, he prevented the escape of the fluid by placing the instrument MN, consisting of a handle and a circular head, upon the interior extremity of the tube, and found, to his great surprise, that when he withdrew the instrument MN, to give passage to the water, it sometimes followed the sides of the tube, and sometimes detached itself from them, and produced a contraction in the fluid vein similar to that which took place when the first tube

was employed. After a little practice, he could produce either of these effects at pleasure. The same phenomenon was exhibited when the length of the tube was diminished to one inch six lines; only it was more difficult to make the fluid follow the circumference of the tube. This effect was still more difficult to produce when its length was reduced to one inch; and when it was so small as half an inch, the water uniformly detached itself from its circumference, and formed the *vena contracta*.

182. TABLE IV. Shewing the Quantities of Water discharged by Cylindrical Tubes one inch in diameter with different lengths.

Variable lengths of the tubes expressed in lines.	Cubic inches discharged in a minute.
Constant altitude of the fluid above the superior base of the tube being 11 feet 8 inches and 10 lines.	The tube being filled with the issuing fluid } 48 12274 24 12188 18 12168
	The tube not filled with the issuing fluid } 18 9282

Quantities of fluid discharged from cylindrical tubes of the same diameters but different lengths.

The experiments in the preceding table were made with tubes inserted in the bottom of the vessel. When the tubes were fixed horizontally in the side of the reservoir, they furnished the very same quantities of fluid, their dimensions and the altitude of the fluid remaining the same.

It appears from the preceding results, that the quantities of water discharged increase with the length of the tube, and that these quantities are very nearly as the square roots of the altitudes of the fluid above the interior orifice of the vertical tube.

We have already seen that the theoretical are to real discharges, as 1 to 0.62, or nearly as 16.1 to 10. But by comparing the two last experiments in the preceding table, it appears that the quantity of fluid discharged by a cylindrical tube where the water follows its sides, is to the quantity discharged by the same tube when the *vena contracta* is formed, as 13 to 10; and since the same quantity must be discharged by the latter method as by a simple orifice, we may conclude

Quantities of water discharged by small tubes.

When the cylindrical tube is two inches long and two in diameter, the fluid vein is contracted as in simple orifices.

Plate CCLXVIII fig. 4.

Experiments on the Motion of Fluids.

clude that the quantity discharged according to theory, and that which is discharged by a cylindrical tube and by a simple orifice, are to one another very nearly as the numbers 16, 13, 10. Though the water therefore follows the sides of the cylindrical tube, the contraction of the fluid vein is not wholly destroyed; for the difference between the quantity discharged in this case, and that deduced from theory, is too great to be ascribed to the increase of friction which arises from the water following the circumference of the tube.

183. In order to determine the effect of tubes of different diameters, under different altitudes of water in the reservoir, M. Bossut instituted the experiments, the results of which are exhibited in the following table.

TABLE V. Shewing the Quantities of Water discharged by Cylindrical Tubes two inches long, with different diameters.

Quantities of water discharged by cylindrical tubes of the same length but different diameters.	Constant altitude of the water above the orifice.		Diameter of the tube.	Quantity of water discharged in a minute.
	Feet.	Inches.		
3	10	}	The tube being filled with the issuing fluid.	6 1689
			The tube not filled with the issuing fluid.	10 4703
			The tube being filled with the issuing fluid.	6 1293
			The tube not filled with the issuing fluid.	10 3598
2	0	}	The tube being filled with the issuing fluid.	6 1222
			The tube not filled with the issuing fluid.	10 3402
				6 935
				10 2603

184. By comparing the different numbers in this table we may conclude,

1. That the quantities of water discharged by different cylindrical tubes of the same length, the altitude of the fluid remaining the same, are nearly as the areas of the orifices, or the squares of their diameter.
2. That the quantities discharged by cylindrical tubes of the same diameter and length, are nearly as the square roots of the altitude of the fluid in the reservoir.
3. Hence the quantities discharged during the same time, by tubes of different diameters, under different altitudes of fluid in the reservoir, are nearly in the compound ratio of the squares of the diameters of the tube, and the square roots of the altitudes of the water in the reservoir.
4. By comparing these results with those which were deduced from the experiments with simple orifices, it will be seen that the discharges follow the same laws in cylindrical tubes as in simple orifices.

185. The following table is deduced from the foregoing experiments, and contains a comparative view of the quantities of water discharged by a simple orifice, according to theory, and those discharged by a cylindrical tube of the same diameter under different altitudes of water. The numbers might have been more accurate by attending to some of the preceding remarks; but they are sufficiently exact for any practical purpose. The fourth column, containing the ratio between the theoretical and actual discharges, was computed by M. Prony.

TABLE VI. Comparison of the Theoretical with the Real Discharges from a Cylindrical Tube one inch in Diameter and two inches Long.

Constant altitude of the water in the reservoir above the centre of the orifice.	Theoretical discharges through a circular orifice one inch in diameter.	Real discharges in the same time by a cylindrical tube one inch in diameter and two inches long.	Ratio of the theoretical to the real discharges.
Pairs Feet.	Cubic inches.	Cubic inches.	
1	4381	3539	1 to 0.81781
2	6196	5002	1 to 0.80729
3	7589	6126	1 to 0.80724
4	8763	7070	1 to 0.80681
5	9797	7900	1 to 0.80638
6	10732	8654	1 to 0.80638
7	11592	9340	1 to 0.80573
8	12392	9975	1 to 0.80496
9	13144	10579	1 to 0.80485
10	13855	11151	1 to 0.80483
11	14530	11693	1 to 0.80477
12	15180	12205	1 to 0.80403
13	15797	12699	1 to 0.80390
14	16393	13177	1 to 0.80382
15	16968	13620	1 to 0.80270
1	2	3	4

By comparing the preceding table with that in art. 174. we shall find that cylindrical tubes discharge a much greater quantity of water than simple orifices of the same diameter, and that the quantities discharged are as 81 to 62 nearly. This is a curious phenomenon, and will be afterwards explained.

186. The application of this table to other additional tubes under different altitudes of the fluid, not contained in the first column, is very simple. Let it be required, for example, to find the quantity of water discharged by a cylindrical tube, 4 inches in diameter, and 8 inches long, the altitude of the fluid in the reservoir being 25 feet. In order to resolve this question, find (by art. 176.) the theoretical quantity discharged which in the present instance will be 350490 cubic inches, and this number diminished in the ratio of 1 to 0.81 will give 284773 for the quantity required. The length of the tube in this example was made 8 inches, because, when the length of the tube is less than twice its diameter, the water does not easily follow its interior circumference. If the tube were longer than 8 inches, the quantity of fluid discharged would have been greater, because it uniformly increases with the length of the tube; the greatest length of the tube being always small, in comparison with the altitude of the fluid in the reservoir.

187. Hitherto we have supposed the tube to be exactly cylindrical. When its interior surface, however, is conical, the quantities discharged undergo a considerable variation, which may be estimated from the following experiments of the marquis Poleni, published in his work *De Castellis per que derivantur fluviorum aqua*, &c. which appeared at Padua in 1718.

Exp
mon
the M
of F
Comp
of the
retica
the re
disch
in cyl
cal ut

Experiments on the Motion of Fluids.

Experiments on the Motion of Fluids.

TABLE VII. *Shewing the Quantities of Water discharged by Conical Tubes of different Diameters.*

		Apertures employed.	Interior diameter.	Exterior diameter.	Quantity discharged in a min. in cubic ft.	Time in which 73035 cub. inches were discharged.
Constant altitude of the water in the reservoir, 256 lines, or 1 foot 9 inches and 4 lines.	Length of each tube 92 lines, or 7 inches 8 lines.	Orifice in a thin plate,	26 lines	26 lines	15877	4' 36"
		Cylindrical tube,	26	26	23434	3' 7"
		1st Conical tube,	33	26	24758	2' 57"
		2d Conical tube,	42	26	24619	2' 58"
		3d Conical tube,	60	26	24345	3' 0"
		4th Conical tube,	118	26	23687	3' 5"

From these experiments we are authorised to conclude, 1. That the real discharges are less than those deduced from theory, which in the present case is 27425 cubic inches in a minute, and 2. That when the interior orifice of the tube is enlarged to a certain degree, the quantity discharged is increased; but that when this enlargement is too great, a contraction takes place without the exterior orifice, and the quantity discharged suffers a diminution. If the smallest base of the conical tube be inserted in the side of the reservoir, it will furnish more water than a cylindrical tube whose diameter is equal to the smallest diameter of the conical tube; for the divergency of its sides changes the oblique motion which the particles would otherwise have had, when passing from the reservoir into the tube.

188. The experiments of Poleni and Bossut having

been made only with tubes of a conical and cylindrical form, M. Venturi was induced to institute a set of experiments, in which he employed tubes of the various forms exhibited in fig. 4. The results of his researches are contained in the following table, for which we have computed the column containing the number of cubic inches discharged in one minute, in order that the experiments of the Italian philosopher may be more easily compared with those which are exhibited in the preceding tables. The constant altitude of the water in the reservoir was 32.5 French inches, or 34.642 English inches. The quantity of water which flowed out of the vessel in the times contained in the first column was 4 French cubic feet, or 4.845 English cubic feet. The measures in the table are all English, unless the contrary be expressed.

TABLE VIII. *Shewing the Quantities of Water discharged from Orifices of various forms, the constant Altitude of the Fluid being 32.5 French, or 34.642 English inches.*

N ^o	Nature and dimensions of the tubes and orifices.	Time in which 4 Paris cub. ft. were discharged.	Paris cubic inches discharged in a minute
1	A simple circular orifice in a thin plate, the diameter of the aperture being 1.6 inches,	Seconds.	
2	A cylindrical tube 1.6 inches in diameter, and 4.8 inches long,	41	10115
3	A tube similar to B, figure 4. which differs from the preceding only in having the contraction in the shape of the natural contracted vein,	31	13378
4	The short conical adjutage, A, figure 4. being the first conical part of the preceding tube,	31	13378
5	The tube D, figure 4. being a cylindrical tube adapted to the small conical end A, <i>mn</i> being 3.2 inches long,	42	9874
6	The same adjutage, <i>mn</i> being 12.8 inches,	42.5	9758
7	The same adjutage, <i>mn</i> being 25.6 inches,	45	9216
8	The tube C, consisting of the cylindrical tube of Exp. 2. placed over the conical part of A,	48	8640
9	The double conical pipe E, <i>a b = a c = 1.6 inches, c d = 0.977 inches, e f = 1.376 inches</i> , and the length <i>cc</i> of the outer cone = 4.351 inches,	32.5	12760
10	The tube F, consisting of a cylindrical tube 3.2 inches long, and 1.376 inches in diameter, interposed between the two conical parts of the preceding,	27.5	15081
		28.5.	14516

Important facts deducible from Venturi's experiments. Fig. 4.

189. These experiments of Venturi inform us of a curious fact, extremely useful to the practical hydraulist. They incontestably prove, that when water is conveyed through a straight cylindrical pipe of an unlimited length, the discharge of water may be increased only by altering the form of the terminations of the pipe, that is, by making the end of the pipe A of the

same form as the *vena contracta*, and by forming the other extremity BC into a truncated one, having its length BC about 9 times the diameter of the cylindrical tube AB, and the aperture at C to that at B, as 18 to 10. By giving this form to the pipe, it will discharge more than twice as much water in a given time, the quantity discharged by the cylindrical pipe being to

5 B 2

Experiments on the Motion of Fluids.

the quantity discharged by the pipe of the form ABC, as 10 to 24.

190. M. Venturi also found, that the quantities of water discharged out of a straight tube, a curved tube forming a quadrantal arc, and an elbowed tube with an angle of 90°, each branch having a horizontal position, are to one another nearly as the numbers 70, 50, 45. Hence we see the disadvantages of sinuosities and bendings in conduit pipes. In the construction of hydraulic machines, any variation in the internal diameter of the pipe ought to be carefully avoided, excepting those alterations at the extremities which we have recommended in the preceding paragraph.

Results of Eytelwein's experiments on additional tubes.

191. It appears from the researches of Eytelwein, that when the shortest tube that will make the water follow its sides is applied to the reservoir, the quantity discharged will be to that deduced from theory, as 0.810 to 1.000, and the multiplier for finding the velocity will be 6.5. When the lengths of the tubes are increased from two to four times their diameter, the ratio of the actual and theoretical discharge will be 0.822 to 1.000, and the constant multiplier for finding the velocity will be 6.6. In employing a conical tube approaching to the figure of the *vena contracta*, the ratio of the discharges was as 0.92 to 1.00, and when its edges were rounded off, as 0.98 to 1.00 computing from its least section. He found also that the smallest quantity of water was discharged, when the interior extremity of the tube projected within the reservoir, the quantity furnished in this case being reduced to one half of what was discharged when the tube had its proper position.

Reason why cylindrical tubes furnish more water than orifices of the same diameter.

192. When a cylindrical tube is applied to an orifice, the oblique motion of the particles which enter it is diminished; the vertical velocity of the particles, therefore, is increased, and consequently the quantity of water discharged. M. Venturi maintains that the pressure of the atmosphere increases the expence of water through a simple cylindrical tube, and that in conical tubes, the pressure of the atmosphere increases the expenture in the ratio of the exterior section of the tube to the section of the contracted vein, whatever be the position of the tube.

Best form for tubes employed to discharge water.

193. Of all the tubes that can be employed for discharging water, that is the most advantageous which has the form of a contracted vein. Hence, it will be a truncated cone with its greatest base next the reservoir, having its length equal to half the diameter of that base, and the area of the two orifices as 8 to 5, or their diameters in the subduplicate ratio of these numbers, viz. as $\sqrt{8} : \sqrt{5}$.

SECT. III. Experiments on the Exhaustion of Vessels.

Difficulty in determining the time when a vessel is completely exhausted.

194. It is almost impossible to determine the exact time in which any vessel of water is completely exhausted. When the surface of the fluid has descended within a few inches of the orifice, a kind of conoidal funnel is formed immediately above the orifice. The pressure of the superincumbent column being therefore removed, the time of exhaustion is prolonged. The water falls in drops; and it is next to impossible to determine the moment when the vessel is empty. Instead, therefore, of endeavouring to ascertain the time in which vessels are completely exhausted, the abbé Bossut has determi-

ned the times in which the superior surface of the fluid descends through a certain vertical height, and his results will be found in the following table.

Experiments on the Motion of Fluids.

TABLE IX. Shewing the times in which Vessels are partly exhausted.

Primitive altitude of the water in the vessel.	Constant area of a horizontal section of the vessel.	Diameter of the circular orifice.	Depression of the upper surface of the fluid.	Time in which this depression takes place.
Paris Feet.	Square Feet.	Inches.	Feet.	Min. Sec.
11.6666	9	1	4	7 25 $\frac{1}{2}$
		2	4	1 52
		1	9	20 24 $\frac{1}{2}$
		2	9	5 6
PG	DE	$\sqrt{\frac{A}{.7854}}$	PG-PU	T

Plate CCLXV fig. 5. 6. Comparison of the experiments with the results of theory.

195. In order to compare these experimental results with those deduced from theory, we must employ the formula (in Prop. V. 156.) where the time in which the surface descends through any height is $T = \frac{DE \times \sqrt{PG - \sqrt{PU}}}{A \sqrt{16.087}}$, in which DE is the area of a sec-

tion of the vessel, PG the primitive altitude of the surface above the centre of the orifice, PU the altitude of the surface after the time T is elapsed, A the area of the orifice, and 16.087 the space through which a heavy body descends in one second of time. That the preceding formula may be corrected, we must substitute $0.62A$ or $\frac{5A}{8}$, instead of A, in the formula, $0.62A$, A

being the area of the *vena contracta*; and as the measures in the preceding table are in Paris feet, we must use 15.085 instead of 16.087, the former being the distance in Paris feet, and the latter the distance in English feet, which falling bodies describe in a second. The

formula, therefore, will become $T = \frac{DE \times \sqrt{PG - PU}}{0.62A \sqrt{15.085}}$,

and when the computations are made for the different diameters of the orifices and the different depressions of the fluid surface, the results will be had, which are exhibited in the last column of the following table, containing the values of T, according to theory and experience.

TABLE X. Comparison of the results of Theory with those of Experience.

Diameter of the circular orifice.	Depression of the upper surface of the fluid.	Time of the depression of the surface by experiment.	Time of the depression of the surface by the formula.	Difference between the theory and the experiments.
Inches.	Feet.	Min. Sec.	Min. Sec.	Seconds.
1	4	7 25 $\frac{1}{2}$	7 22.36	3.14
2	4	1 52	1 50.59	1.41
1	9	20 24 $\frac{1}{2}$	20 16	8.50
2	9	5 6	5 4	2.00

Experiments on the Motion of Fluids.

It appears from this table that the times of discharge, by experiment, differ very little from those deduced from the corrected formula; and that the latter always err in defect. This may arise from 0.62 being too great a multiplier for finding the corrected diameter of the orifice.—When the orifices are in the sides of the reservoir, the altitude PG, PU of the surface may be reckoned from the centre of gravity of the orifice, unless when it is very large.

SECT. IV. Experiments on Vertical and Oblique Jets.

Experiments on the Motion of Fluids.

196. We have already seen, that, according to theory, vertical jets should rise to the same altitude as that of the reservoirs from which they are supplied. It will appear, however, from the following experiments of Bossut, that jets do not rise exactly to this height. This arises from the friction at the orifice, the resistance of the air, and other causes which shall afterwards be explained.

TABLE XI. Containing the Altitudes to which Jets rise through Adjustages of different forms, the Altitude of the Reservoir being Eleven Feet, reckoning from the upper surface of the horizontal Tubes m n P, o p R.

Plate CLXVIII. fig. 6.

Diameter of the horizontal tubes mP, nR, each being six feet long.	Form of the orifices.	References to Fig. 6.	Diameter of the orifice.	Altitude of the jet when rising vertically, reckoning from ω .	Altitude of the jet when inclined a little to the vertical.	Description of the jets.
Inch. Lines.			Lines.	Feet. Inch. Lines.	Feet. Inch. Lines.	
3 8	Simple orifice	H	2	10 0 10	10 4 6	The vertical jet beautiful.
3 8	————	G	4	10 5 10	10 7 6	The vertical jet beautiful, not much enlarged at the top.
3 8	————	F	8	10 6 6	10 8 0	All the jets occasionally rise to different heights. This very perceptible in the present experiment. The vertical jet much enlarged at top. The inclined one less so, and more beautiful.
3 8	Conical tube	E	94 by 70	9 6 4	9 8 6	The vertical jet beautiful.
3 8	Cylindrical tube	D	4 by 70	9 1 6	7 3 6	The vertical jet beautiful.
0 9½	Simple orifice	M	2	9 11 0	— — —	The jet beautiful.
0 9½	————	L	4	9 7 10	— — —	The jet much deformed, and very much enlarged at top.
0 9½	————	K	8	7 10 0	— — —	The column much broken; and the successive jets are detached from each other.

197. It appears, from the three first experiments of the preceding table, that *great jets rise higher than small ones*; and from the three last experiments, that *small jets rise higher than great ones when the horizontal tube is very narrow*. There is therefore a certain proportion between the diameter of the horizontal tube and that of the adjustage or orifice, which will give a maximum height to the jet. This proportion may be found in the following manner. Let D be the diameter of the tube, d that of the adjustage, a the altitude B m of the reservoir, b the velocity along the tube; and as the velocity at the adjustage is constant, it may be expressed by \sqrt{a} . Now (art. 150. note) the velocity in the tube is to the velocity at the adjustage as the area of their respective sections, that is, as the square of the diameter of the one is to the square of the diameter of the other. Therefore, $\sqrt{g} : b = D^2 : d^2$, and consequently $b =$

$\frac{d^2 \sqrt{a}}{D^2}$. If there is another tube and another adjustage, the corresponding quantities may be the same letters in the Greek character, viz. $\Delta, \delta, \alpha, \beta$, and we shall have the equation $\beta = \frac{\delta^2 \sqrt{\alpha}}{\Delta^2}$. If we wish, therefore, that the two jets be furnished in the same manner, then if the velocity in the first tube leaves to the first jet all the height possible, the velocity in the second tube leaves also to the second jet all the height possible, and we shall have $b = \beta$, or $\frac{d^2 \sqrt{a}}{D^2} = \frac{\delta^2 \sqrt{\alpha}}{\Delta^2}$. Hence $D^2 : \Delta^2 = dd\sqrt{a} : \delta\delta\sqrt{\alpha}$, that is, the squares of the diameters of the horizontal tubes ought to be to one another in the compound ratio of the squares of the diameters of the adjustages, and the square roots of the altitudes of the reservoir.

Ratio between the diameters of the tube and the adjustage for producing a maximum height to the jet.

Experiments on the Motion of Fluids.

voir. Now, it appears from the experiments of Mariotte (*Traité de mouvement des eaux*), that when the altitude of the reservoir is 16 feet, and the diameter of the adjutage six lines, the diameter of the horizontal tube ought to be 28 lines and a half. By taking this as a standard, therefore, the diameters of the horizontal tube may be easily found by the preceding rule, whatever be the altitude of the reservoir and the diameter of the adjutage.

It results from the three last experiments, that the jets rise to the smaller height when the adjutage is a cylindrical tube (see D fig. 6.), that a conical adjutage throws the fluid very much higher, and that when the adjutage is a simple orifice the jet rises highest of all.

Fig. 6.

198. By comparing the preceding experiments with those of Mariotte, it appears, that the differences between the heights of vertical jets, and the heights of the reservoir, are nearly as the squares of the heights of the jets. Thus, $ab : cd = Eb^2 : Fd^2$; therefore, if ab be known by experiment, we shall have $cd = \frac{ab \times Fd^2}{Eb^2}$, and

by adding cd to Fd , we shall have the altitude of the reservoir. But if Fc were given, and it were required to find Fd , the height of the jet, we have, by the preceding analogy, $Fd^2 = \frac{Eb^2 \times cd}{ab}$. But cd is an unknown

quantity, and is equal to $Fc - Fd$, therefore, by substitution, $Fd^2 = \frac{Eb^2 \times Fc - Fd}{ab}$, or $Fd^2 \times \frac{Eb^2}{ab} \times Fd = \frac{Eb^2 \times Fc}{ab}$, which is evidently a quadratic equation, which, after reduction, becomes $Fd = \sqrt{\frac{Eb^2 \times Fc}{ab} + \frac{Eb^2}{4} - \frac{Eb^2}{2}}$.

A small inclination of the table, if the jet increases its altitude.

199. From a comparison of the 5th and 6th columns of the table, it appears that a small inclination of the jet, to a vertical line, makes it rise higher than when it ascends exactly vertical (κ); but even then it still falls short of the height of the reservoir. When the water first escapes from the adjutage, it generally springs higher than the reservoir; but this effect is merely momentary, as the jet instantly subsides, and continues at the altitudes exhibited in the foregoing tables. The great size of the jet at its first formation, and its subsequent diminution, have been ascribed by some philosophers to the elasticity of the air which follows the water in its passage through the orifice; but it is obvious, that this air, which moves along with the fluid, can never give it an impulsive force. In order to explain this phenomenon, let us suppose the adjutage to be stopped; then the air which the water drags along with it, will lodge itself at the extremity of the adjutage, so that there will be no water contiguous to the body which covers the orifice. As soon as the cover is removed from the adjutage, the imprisoned air escapes; the water immediately behind it rushes into the space which it leaves, and thus acquires in the tube a certain velocity which increases at the orifice in the ratio of the area of the section of the tube to the area of the section of the orifice (art. 150. note). When the orifice is small in compa-

The jet rises higher than the reservoir at its commencement.

rise with the tube, the velocity of the issuing fluid must be considerable, and will raise it higher than the reservoir. But as the jet is resisted by the air, and retarded by the descending fluid, its altitude diminishes, and the simple pressure of the fluid becomes the only permanent source of its velocity. The preceding phenomenon was first noticed by Torricellius, who seems to ascribe the diminution in the altitude of the jet to the gravity of the descending particles.

200. The following table exhibits all that is necessary in the formation of jets. The two first columns are taken from Mariotte, and shew the altitude of the reservoir requisite to producing a jet of a certain height. The third column contains, in Paris pints, 36 of which are equal to a cubic foot, the quantity of water discharged in a minute by an orifice six lines in diameter. The fourth column, computed from the hypothesis in art. 197. contains the diameters of the horizontal tubes for an adjutage six lines in diameter, relative to the altitudes in the second column. The thickness of the horizontal tubes will be determined in a subsequent section.

TABLE XII. Containing the Altitudes of Reservoirs, the Diameters of the Horizontal Tubes, &c. for Jets of different heights.

Altitude of the jet.	Altitude of the reservoir.	Quantity of water discharged in a minute from an adjutage 6 lines in diam.	Diameters of the horizontal tubes suited to the two preceding columns.
Paris Feet.	Feet. Inches.	Paris Pints.	Lines.
5	5 1	32	21
10	10 4	45	26
15	15 9	56	28
20	21 4	65	31
25	27 1	73	33
30	33 0	81	34
35	39 1	88	36
40	45 4	95	37
45	51 9	101	38
50	58 4	108	39
55	65 1	114	40
60	72 0	120	41
65	79 1	125	42
70	86 4	131	43
75	93 9	136	44
80	101 4	142	45
85	109 1	147	46
90	117 0	152	47
95	125 1	158	48
100	133 4	163	49

201. We have already seen that jets do not rise to the heights of their reservoirs; and have remarked that the difference between theory and experiment arises from the friction at the orifice, and the resistance of the air. The diminution of velocity produced by friction is very small, and the resistance of the air is a very inconsiderable

(κ) This was also observed by Wolfius, *Opera Mathematica*, tom. i. p. 802. Schol. iv.

Experiments on the Motion of Fluids
 * Wolfii Opera Mathematica. tom. I. p. 802. schol. 4.

Experiments on the Motion of Fluids.

considerable source of retardation, unless when the jet rises to a great altitude. We must seek therefore for another cause of obstruction to the rising jet, which, when combined with these, may be adequate to the effect produced. Wolfius* has very properly ascribed the diminution in the altitude of the jet to the gravity of the falling water. When the velocity of the foremost particles is completely spent, those immediately behind by impinging against them lose their velocity, and, in consequence of this constant struggle between the ascending and descending fluid, the jet continues at an altitude less than that of the reservoir. Hence we may discover the reason why an inclination of the jet increases its altitude; for the descending fluid falling a little to one side does not encounter the rising particles, and therefore permits them to reach a greater altitude, than when their ascension is in a vertical line. Wolfius observes, in proof of his remark that the diminution is occasioned also by the weight of the ascending fluid, that mercury rises to a less height than water: but this cannot be owing to the greater specific gravity of mercury; for though the weight of the mercurial particles is greater than that of water, yet the momentum with which they ascend is proportionally greater, and therefore the resistance which opposes their tendency downwards, has the same relation to their gravity, as the resistance in the case of water has to the weight of the aqueous particles.

202. The theory of oblique jets has already been discussed in Prop. IX. art. 161. The two following experiments of Bossut contain all that is necessary to be known in practice. When the height NS of the reservoir AB was 9 feet, and the diameter of the adjutage at N, 6 lines, a vertical abscissa CN of 4 feet 3 inches and 7 lines, answered to a horizontal ordinate CT of 11 feet 3 inches and 3 lines. When the altitude NS of the reservoir was 4 feet, the adjutage remaining the same, a vertical abscissa CN of 4 feet 3 inches, and 7 lines, corresponded with a horizontal ordinate CT of 8 feet 2 inches and 8 lines. The real amplitudes, therefore, are less than those deduced from theory; and both are very nearly as the square roots of the altitudes of the reservoirs. Hence, to find the amplitude of a jet when the height of the reservoir is 10 feet, and the vertical ab-

scissa the same, we have $\sqrt{9}$ feet : $\sqrt{16}$ feet = 11 feet 3 inches 3 lines : 15 feet 4 lines, the amplitude of the jet required. This rule, however, will apply only to small reservoirs; for when the jets enlarge, the curve which they describe cannot be determined by theory, and therefore the relation between the amplitudes and the heights of the reservoirs must be uncertain.

SECT. V. Experiments on the Motion of Water in Conduit Pipes.

203. The experiments of the chevalier de Buat, will be given at great length in the article *Water-Works*, for which we have been indebted to the late learned Dr Robison. That the reader, however, may be in possession of every thing valuable on a subject of such public importance, we shall at present give a concise view of the experiments of Couplet and Bossut, and of the practical conclusions which they authorize us to form.

204. It must be evident to every reader, that, when water is conducted from a reservoir by means of a long horizontal pipe, the velocity with which the water enters the pipe will be much greater than the velocity with which it issues from its farther extremity; and, that if the pipe has various flexures or bendings, the velocity with which the water leaves the pipe will be still farther diminished. The difference, therefore, between the initial velocity of the water, and the velocity with which it issues, will increase with the length of the pipe and the number of its flexures. By means of the theory, corrected by the preceding experiments, it is easy to determine with great accuracy the initial velocity of the water, or that with which it enters the pipe; but on the obstructions which the fluid experiences in its progress through the pipe, and on the causes of these obstructions, theory throws but a feeble light. The experiments of Bossut afford much instruction on this subject; and it is from them that we have arranged the following table, containing the quantities of water discharged by pipes of different lengths and diameters, compared with the quantities discharged from additional tubes.

TABLE

Experiments on oblique jets
 Plate CCLXVIII
 fig. 2.

Experiments on the Motion of Fluids.

Experiments on the Motion of Fluids.

TABLE XIII.—Containing the Quantities of Water discharged by Conduit Pipes of different lengths and diameters, compared with the Quantities discharged from additional tubes inserted in the same Reservoir.

Constant altitude of the water in the reservoir above the axis of the tube.	Length of the conduit Pipes.	Quantity of water discharged in a minute by an additional tube.	Quantity of water discharged by the conduit pipe in a minute.	Ratio between the quantities of water furnished by the tube and the pipe of 16 lines diameter.	Quantity of water discharged by an additional tube in a minute	Quantity of water discharged by the conduit pipe in a minute.	Ratio between the quantities of water furnished by the tube and the pipe of 24 lines diameter.
		Tube and pipe 16 lines diam.			Tube and pipe 24 lines diam.		
Feet.	Feet.	Cubic Inches.	Cubic Inches.		Cubic Inches.	Cubic Inches.	
1	30	6330	2778	1 to .4389	14243	7680	1 to .5392
1	60	6330	1957	1 to .3091	14243	5564	1 to .3906
1	90	6330	1587	1 to .2507	14243	4534	1 to .3183
1	120	6330	1351	1 to .2134	14243	3944	1 to .2769
1	150	6330	1178	1 to .1861	14243	3486	1 to .2448
1	180	6330	1052	1 to .1662	14243	3119	1 to .2190
2	30	8939	4066	1 to .4548	20112	11219	1 to .5578
2	60	8939	2888	1 to .3231	20112	8190	1 to .4072
2	90	8939	2352	1 to .2631	20112	6812	1 to .3387
2	120	8939	2011	1 to .2250	20112	5885	1 to .2926
2	150	8939	1762	1 to .1971	20112	5232	1 to .2601
2	180	8939	1583	1 to .1770	20112	4710	1 to .2341
1	2	3	4	5	6	7	8

Deductions from the preceding table.

205. The third column of the preceding table contains the quantity of water discharged through an additional cylindrical tube 16 lines in diameter, or the quantity discharged from the reservoir into a conduit pipe of the same diameter; and the fourth column contains the quantity discharged by the conduit pipe. The fifth column, therefore, which contains the ratio between these quantities, will also contain the ratio between the velocity of the water at its entrance into the conduit pipe, which we shall afterwards call its initial velocity, and its velocity when it issues from the pipe, which shall be denominated its final velocity; for the velocities are as the quantities discharged, when the orifices are the same. The same may be said of the 6th, 7th, and 8th columns, with this difference only, that they apply to a cylindrical tube and a conduit pipe 24 lines in diameter.

Cause of the retardation of water in moving pipes.

206. By examining some of the experiments in the foregoing table, it will appear, that the water sometimes loses $\frac{1}{10}$ ths of its initial velocity. The velocity thus lost is consumed by the friction of the water on the sides of the pipe, as the quantities discharged, and consequently the velocities, diminish when the length of the pipe is increased. In simple orifices, the friction is in the inverse ratio of their diameter; and it appears from the table, that the velocity of the water is more retarded in the pipe 16 lines in diameter, than in the other, which has a diameter of 24 lines. But though the velocity decreases when the length of the tube is increased, it by no means decreases in a regular arithmetical progression, as some authors have maintained. This is obvious from the table, from which it appears, that the differences between the quantities discharged, which represent also the differences between the velocities, always decrease, whereas the differences would have been equal,

had the velocities decreased in an arithmetical progression. The same truth is capable of a physical explanation. If every filament of the fluid rubbed against the sides of the conduit pipe, then, since in equal times they all experience the same degree of friction, the velocities must diminish in the direct ratio of the lengths of the tubes, and will form a regular arithmetical progression, of which the first term will be the final, and the last the initial velocity of the water. But it is only the lateral filaments that are exposed to friction. This retards their motion; and the adjacent filaments which do not touch the pipe, by the adhesion to those which do touch it, experience also a retardation, but in a less degree, and go on with the rest, each filament sustaining a diminution of velocity inversely proportional to its distance from the sides of the pipe. The lateral filaments alone, therefore, provided they always remain in contact with the sides of the pipe, will have their velocities diminished in arithmetical progression, while the velocities of the central filaments will not decrease in a much slower progression; consequently, the mean velocity of the fluid, or that to which the quantities discharged are proportional, will decrease less rapidly than the terms of an arithmetical progression.

207. When the altitude of the reservoir was two feet, the diminution of discharge, and consequently of velocity, was greater than when the height of the reservoir was only one foot. The cause of this is manifest. Friction increases with the velocity, because a greater number of obstructions are encountered in a certain time, and the velocities are as the square roots of the altitudes; therefore friction must also be as the square roots of the altitudes of the reservoir. On some occasions Coulomb found that the friction of solid bodies diminished with an augmentation of velocity, but there is no ground for

Experiments on the Motion of Fluids. In inclined pipes the velocity of the fluid is increased by its relative gravity. Plate CCLXVIII. § 7.

208. When the pipe is inclined to the horizon, as CGF, the water will move with a greater velocity than in the horizontal tube CG *h* *f*. In the former case, the relative gravity of the water, which is to its absolute gravity as *Ff* to *Cf*, or as the height of the inclined plane to its length, accelerates its motion along the tube. But this acceleration takes place only when the inclination is considerable; for if the angle which the direction of the pipe forms with the horizon were no more than one degree, the retardation of friction would completely counterbalance the acceleration of gravity. Thus when the pipe CF, 16 lines in diameter, was 177 feet, and was divided into three equal parts in the points D and E, so that CD was 59 feet, CE 118 feet; and when CF was to *Ff* as 2124 to 241, the quantity of water discharged at F was 5795 cubic inches in a minute, the quantity discharged at E was 5801 cubic inches in a minute, and the quantity at D 5808 cubic

inches. The quantities discharged therefore, and consequently the velocities, decreased from C to F; whereas if there had been no friction, and no adhesion between the aqueous particles, the velocities would have increased along the line CF in the subduplicate ratio of the altitudes CB, D *m*, E *n*, and F *o*; AB being the surface of the water in the reservoir. The preceding numbers, representing the quantities discharged at F, E, and D, decrease very slowly; consequently by increasing the relative gravity of the water, that is, by inclining the tube more to the horizon, the effects of friction may be exactly counterbalanced. This happens when the angle *f*CF is about 6° 31', or when *Ff* is the eighth or ninth part of CF. The quantities discharged at C, D, E, and F, will be then equal, and friction will have consumed the velocity arising from the relative gravity of the included water.

Experiments on the Motion of Fluids. Friction de-stroys this increase of velocity when the inclination is 6° 31'.

209. In order to determine the effects produced by flexures or sinuosities in conduit pipes, M. Bossut made the following experiments.

TABLE XIV. Shewing the Quantities of Water discharged by rectilinear and curvilinear Pipes 50 Feet long, and 1 Inch in Diameter.

Altitude of the Water in the Reservoir:	Form of the conduit Pipes.—See Figures 8. and 9.	Quantities of Water discharged in a Minute.
Feet. Inches.		Cubic Inches
0 4	The rectilinear tube MN placed horizontally,	576
1 0	The same tube similarly placed,	1050
0 4	The same tube bent into the curvilinear form ABC, fig. 8. each flexure lying flat on a horizontal plane, ABC being a horizontal section,	540
1 0	The same tube similarly placed,	1030
0 4	The same tube placed as in fig. 9. where ABCD is a vertical section, the parts A, B, C, D rising above a horizontal plane, and the parts <i>a</i> , <i>b</i> , <i>c</i> lying upon it,	520
1 0	The same tube similarly placed,	1028

Experiments with curvilinear pipes.

210. 1. The two first experiments of the foregoing table shew, that the quantities discharged diminish as the altitude of the reservoir. This arises from an increase of velocity, which produces an increase of friction.

2. The four first experiments shew, that a curvilinear pipe, in which the flexures lie horizontally, discharges less water than a rectilinear pipe of the same length. The friction being the same in both cases, this difference must arise from the impulse of the fluid against the angles of the tube; for if the tube formed an accurate curve, it is demonstrable that the curvature would not diminish the velocity of the water.

3. By comparing the 1st and 5th, and the 2d and 6th experiments, it appears, that when the flexures are vertical, the quantity discharged is diminished. This also arises from the imperfection of curvature.

4. It appears from a comparison of the 3d and 5th, with the 4th and 6th experiments, that when the flexures are vertical, the quantity discharged is less than when they are horizontal. In the former case, the motion of the fluid arises from the central impulsion of the

water, retarded by its gravity in the ascending parts of the pipe, and accelerated in the descending parts; whereas the motion, in the latter case, arises wholly from the central impulsion of the fluid. To these points of difference the diminution of velocity may somehow or other be owing.

When a large pipe has a number of contrary flexures, the air sometimes mixes with the water, and occupies the highest parts of each flexure as at B and C, fig. 9. By this means the velocity of the fluid is greatly retarded, and the quantities discharged much diminished. This ought to be prevented by placing small tubes at B and C, having a small valve at their top.

211. A set of valuable experiments on a large scale were made by M. Couplet upon the motion of water in conduit pipes, and are detailed in the Memoirs of the Academy for 1732, in his paper entitled *Des Recherches sur le mouvement des eaux dans les tuyaux de conduite*. These experiments are combined with those of the Abbé Bossut in the following table, which gives a distinct view of all that they have done on this subject, and will be of great use to the practical hydraulist.

Experiments on the Motion of Fluids.

TABLE XV. Containing the results of the Experiments of Couplet and Bossut on Conduit Pipes differing in form, length, diameter, and in the materials of which they are composed,—under different Altitudes of water in the Reservoir.

Table containing the results of the experiments of Couplet and Bossut on conduit pipes of various kinds.

Altitude of the Water in the Reservoir.			Length of the Conduit Pipes.	Diameter of the Conduit Pipes.	Nature, Position, and Form of the Conduit Pipes.	Ratio between the Quantities which would be discharged if the Fluid experienced no resistance in the pipes, and the Quantities actually discharged:—or the Ratio between the initial and the final Velocities of the Fluid.
Feet.	Inch.	Line.	Feet.	Lines.		
0	4	0	50	12	Rectilinear and horizontal pipe made of lead,	I to 0.281
1	0	0	50	12	The same pipe similarly placed,	I to 0.305
0	4	0	50	12	The same pipe with several horizontal flexures,	I to 0.264
1	0	0	50	12	Same pipe,	I to 0.291
0	4	0	50	12	The same pipe with several vertical flexures,	I to 0.254
1	0	0	50	12	Same pipe,	I to 0.290
1	0	0	180	16	Rectilinear and horizontal pipe made of white iron,	I to 0.166
2	0	0	180	16	Same pipe,	I to 0.177
1	0	0	180	24	Rectilinear and horizontal pipe made of white iron,	I to 0.218
2	0	0	180	24	Same pipe,	I to 0.234
20	11	0	177	16	Rectilinear pipe made of white iron, and inclined so that CF (fig. 7.) is to Ff as 2124 is to 241,	I to 0.2000
13	4	8	118	16	Rectilinear pipe made of white iron, and inclined like the last,	I to 0.2500
6	8	4	159	16	Rectilinear pipe made of white iron, and inclined like the last,	I to 0.354
0	9	0	1782	48	Conduit pipe almost entirely of iron, with several flexures both horizontal and vertical,	I to 0.350
1	9	0	1782	48	Same pipe,	I to 0.0376
2	7	0	1782	48	Same pipe,	I to 0.0387
0	3	0	1710	72	Conduit pipe almost entirely of iron, with several flexures both horizontal and vertical,	I to 0.0809
0	5	3	1710	72	Same pipe,	I to 0.0878
0	5	7	7020	60	Conduit pipe, partly stone and partly lead, with several flexures both horizontal and vertical,	I to 0.0432
0	11	4	7020	60	Same pipe,	I to 0.0476
1	4	9	7020	60	Same pipe,	I to 0.0513
1	9	1	7020	60	Same pipe,	I to 0.0532
2	1	0	7020	60	Same pipe,	I to 0.0541
12	1	3	3600	144	Conduit pipe made of iron, with flexures both horizontal and vertical,	I to 0.0992
12	1	3	3600	216	Conduit pipe made of iron, with several flexures both horizontal and vertical,	I to 0.1653
4	7	6	4740	216	Conduit pipe made of iron, with several flexures both horizontal and vertical,	I to 0.0989
20	3	0	14040	144	Conduit pipe made of iron, with several flexures both horizontal and vertical,	I to 0.0517

Application and use of the preceding table:

212. In order to shew the application of the preceding results, let us suppose, that a spring, or number of springs combined, furnishes 40,000 cubic inches of water in one minute; and that it is required to conduct it to a given place 4 feet below the level of the spring, and so situated that the length of the pipe must be 2400 feet. It appears from Table VI. art. 185. that the quantity of water furnished in a minute by a short cylindrical tube, when the altitude of the fluid in the reservoir is 4 feet, is 7070 cubic inches; and since the quantities furnished by two cylindrical pipes under the same altitude of water are as the squares of their dia-

eters, we shall have by the following analogy the diameter of the tube necessary for discharging 40,000 cubic inches in a minute; $\sqrt{70720} : \sqrt{40000} = 12$ lines or 1 inch : 28.7 lines, the diameter required. But by comparing some of the experiments in the preceding table, it appears, that when the length of the pipe is nearly 2400 feet, it will admit only about one-eighth of the water, that is, about 5000 cubic inches. That the pipe, however, may transmit the whole 40000 cubic inches, its diameter must be increased. The following analogy, therefore, will furnish us with this new diameter; $\sqrt{5000} : \sqrt{40000} = 28.54$ lines : 86.73 lines, or 6 inches $\frac{8}{15}$

Experiments on the Motion of Fluids.

8 1/2 lines, the diameter of the pipe which will discharge 40000 cub. inches of water when its length is 2400 feet.

SECT. VI. Experiments on the Pressure exerted upon Pipes by the water which flows through them.

Experiments on the pressure sustained by pipes.

213. The pressure exerted upon the sides of conduit pipes by the included water, has been already investigated theoretically in Prop. X. Part II. The only way of ascertaining by experiment the magnitude of this lateral pressure is to make an orifice in the side of the

pipe, and find the quantity of water which it discharges in a given time. This lateral pressure is the force which impels the water through the orifice; and therefore the quantity discharged, or the effect produced, must be always proportional to that pressure as its producing cause, and may be employed to represent it. The following table, founded on the experiments of Bossut, contains the quantities of water discharged from a lateral orifice about 3 1/2 lines in diameter, according to theory and experiment.

Experiments on the Motion of Fluids.

TABLE XVI. Containing the Quantities discharged by a Lateral Orifice, or the Pressures on the Sides of Pipes, according to Theory and Experiment.

Altitude of the Water in the Reservoir.	Length of the Conduit Pipe.	Quantities of Water discharged in 1 Minute, according to Theory.	Quantities of Water discharged in 1 Minute according to Experiment.
Feet.	Feet.	Cubic Inches.	Cubic Inches.
1	30	176	171
1	60	186	186
1	90	190	190
1	120	191	191
1	150	192	193
1	180	193	194
2	30	244	240
2	60	259	256
2	90	264	261
2	120	267	264
2	150	268	265
2	180	269	266

It appears from the preceding table, that the real lateral pressure in conduit pipes differs very little from that which is computed from the formula; but in order that this accordance may take place, the orifice must be so perforated, that its circumference is exactly perpendicular to the direction of the water, otherwise a portion of the water discharged would be owing to the direct motion of the included fluid.

SECT. VII. Experiments on the Motion of Water in Canals.

Experiments on the velocity of water in horizontal canals.

214. AMONG the numerous experiments which have been made on this important subject, those of the Abbé Bossut seem entitled to the greatest confidence. His experiments were made on a rectangular canal 105 feet long, 5 inches broad at the bottom, and from 8 to 9

inches deep. The orifice which transmitted the water from the reservoir into the canal was rectangular, having its horizontal base constantly 5 inches, and its vertical height sometimes half an inch, and at other times an inch. The sides of this orifice were made of copper, and rising perpendicularly from the side of the reservoir they formed two vertical planes parallel to each other. This projecting orifice was fitted into the canal, which was divided into 5 equal parts of 21 feet each, and also into 3 equal parts of 35, and the time was noted which the water employed in reaching these points of division. The arrival of the water at these points was signified by the motion of a very small water wheel placed at each, and impelled by the stream. When the canal was horizontal, the following results were obtained.

TABLE XVII. Containing the Velocity of Water in a Rectangular Horizontal Canal 105 Feet long, under different Altitudes of Fluid in the Reservoir.

Altitude of the water in the reservoir.	Ft. In. 11 8	Ft. In. 7 8	Ft. In. 3 8	Ft. In. 11 8	Ft. In. 7 8	Ft. In. 9 8	Space run through by the water.
Vertical breadth of the orifice.	3/4 an inch.	1/2 an inch.	1/4 an inch.	1 inch.	1 inch.	1 inch.	Feet.
Time in which the number of feet in column seventh are run through by the water.	2" 5- 10- 16- 23+	3"- 7 13- 20- 28+	3"+ 9 17+ 27+ 38+	2" 4 7 11 16 1/2	2"+ 5 9 14 20	3" 6+ 11+ 18+ 26	21 42 63 84 105

Deductions from the preceding experiments.

215. It appears from column 1st, that the times successively employed to run through spaces of 21 feet each, are as the numbers 2, 3-, 5, 6, 7+, which form nearly an

arithmetical progression, whose terms differ nearly by 1, so that by continuing the progression, we may determine very nearly the time in which the fluid would run through

Experiments on the Motion of Fluids.

through any number of feet not contained in the 7th column. The same may be done with the other columns of the table.

If we compute theoretically the time which the water should employ in running through the whole length of the canal, or 105 feet, we shall find, that under the circumstances for each column of the preceding table the times, reckoning from the first column, are 6".350, 7".834, 11".330, 6".350, 7".834, 11".330. It appears, therefore, by comparing these times with those found by experiment, that the velocity of the stream is very much retarded by friction, and that this retarda-

tion is less as the breadth of the orifice is increased; for since a greater quantity of water issues in this case from the reservoir, it has more power to overcome the obstacles which obstruct its progress. The signs + and - affixed to the numbers in the preceding table indicate, that these numbers are a little too great or too small.

216. The following experiments were made on inclined canals with different declivities, and will be of great use to the practical hydraulist. The inclination of the canal is the vertical distance of one of its extremities from a horizontal line which passes through its other extremity.

TABLE XVIII. Containing the Velocity of Water in a Rectangular inclined Canal 105 Feet long, and under different Altitudes of Fluid in the Reservoir.

Table of the velocity of water in rectangular inclined canals.

Altitude of water in the reservoir.	Ft. In.	Ft. In.	Ft. In.	Ft. In.	Ft. In.	Ft. In.	Space run through by the Water.
Inclination of the canal.	0 3	0 3	0 3	0 6	0 6	0 6	Fcet.
Height of the orifice $\frac{1}{2}$ an inch.	4" 11+ 22	4"+ 14+ 26	6"+ 18+ 34+	3" $\frac{1}{2}$ 11 $\frac{1}{2}$ 21	4+ 14 25+	6 18- 31+	35 70 105
Inclination of the canal.	0 6	0 6	0 6	1 0	1 0	1 0	
Height of the orifice 1 inch.	3" 8 15	4"- 9+ 19-	5"- 13- 23-	3"- 7 $\frac{1}{2}$ 14	4"- 9 16	5- 12 21	35 70 105
Inclination of the canal.	2 0	2 0	2 0	4 0	4 0	4 0	
Height of the orifice 1 inch.	2"+ 7 13	4"- 9- 15-	4" 10 $\frac{1}{2}$ 17 $\frac{1}{2}$	2"+ 6 $\frac{1}{2}$ 12	3"+ 8 13	4+ 9+ 15+	35 70 105
Inclination of the canal.	6 0	6 0	6 0	9 0	9 0	9 0	
Height of the orifice 1 inch.	2"+ 6 10	3" 7+ 12	4" 9- 14-	2"+ 6- 9	3"+ 6 $\frac{1}{2}$ 10	4"- 8- 12-	35 70 105
Inclination of the canal.	Fcet. 11	Fcet. 11	Fcet. 11	Fcet. 11	Fcet. 11	Fcet. 11	
In the three first columns the height of the orifice was $\frac{1}{2}$ an inch, and in the three last 1 inch.	Half sec. 2+ 7 12 17 21+	Half sec. 3+ 8+ 13+ 18+ 23+	Half sec. 4+ 10 16 22 28	Half sec. 2 5 9 13 17	Half sec. 3+ 7 11 15 19	Half sec. 3 8 13 18- 22	21 42 63 84 105
Inclination of the canal.	Fcet. 11	Fcet. 11	Fcet. 11				
Height of the orifice 1 $\frac{1}{2}$ inches.	Half sec. 2 5 8+ 12 15+	Half sec. 3- 6 10- 13+ 17	Half sec. 3+ 7 11+ 15 20				21 42 63 84 105
Time in which the number of feet in the last col. is run through by the water.							

Experiments on the Motion of Fluids. 217. In the preceding experiments the velocity of the first portion of water that issues from the reservoir was only observed; but when the current is once established, and its velocity permanent, it moves with greater rapidity, and there is always a fixed proportion between the velocity of the first portion of water and the permanent velocity of the established current. The cause of this difference Bossut does not seem to have thoroughly comprehended, when he ascribes it to a diminution of friction when the velocity becomes permanent. The velocity of the first portion of water that issues from the reservoir was measured by its arrival at certain divisions of the canal, consequently the velocity thus determined was the mean velocity of the water. The velocity of the established current, on the contrary, was measured by light bodies floating upon its surface, at the centre

of the canal, therefore the velocity thus determined was the superficial velocity of the stream. But the velocity of the superficial central filaments must be the greatest of all, because being at the greatest distance from the sides and bottom of the canal they are less affected by friction than any of the adjacent or inferior filaments, and are not retarded by the weight of any superincumbent fluid. The superficial velocity of the current must of consequence be greater than its mean velocity, or, in other words, the velocity of the established current must exceed the velocity of the first portion of water. The following table contains the experiments of Bossut on this subject; the canal being of the same size as in the former experiments, but 600 feet long, and its inclination one-tenth of the whole, or 59.702 feet.

TABLE XIX. Containing a Comparison between the Velocity of the First Portion of Water, and that of the Established Current.

Altitude of the water in the reservoir.		Vertical breadth of the orifice 1 inch.		Vertical breadth of the orifice 2 inches.		Space run through by the water.
		Vel. of the 1st portion of water.	Vel. of the established current.	Vel. of the 1st portion of water.	Vel. of the established current.	
Feet.	Inches.	Seconds.	Seconds.	Seconds.	Seconds.	Feet.
4	0	10	8	8	7	100
4	0	20+	17	17	14½	200
4	0	31—	26	26	22	300
4	0	42—	35	35—	29+	400
4	0	52½	43+	43+	37—	500
4	0	62+	52	52—	44+	600
2	0	11	10	9	8—	100
2	0	23	20	19	16	200
2	0	35	30	29	24	300
2	0	46+	40	39	32	400
2	0	58	49	49	40	500
2	0	69	58	58	48	600
1	0	12+	12	15	13	100
1	0	25½	23+	31	26½	200
1	0	39	33	47	39½	300
0	6	11—	9	13½	11½	100
0	6	22	18—	26½	23	200
0	6	32	27	39½	33½	300

The common theory of the motion of fluids defective in not considering the temperature of the water employed. 218. In all the experiments related in this chapter, and in those of the Chevalier Buat, which are given in the article *WATER-Works*, the temperature of the water employed has never been taken into consideration. That the fluidity of water is increased by heat can scarcely admit of a doubt. Professor Leslie, in his ingenious paper on Capillary Action, has proved by experiment that a jet of warm water will spring much higher than a jet of cold water, and that a syphon which discharges cold water only by drops, will discharge water of a high temperature in a continued stream. A si-

ilar fact was observed by the ancients. Plutarch (L) Warm water in particular assures us, that the clepsydræ or water clocks went slower in winter than in summer, and he seems to attribute this retardation to a diminution of fluidity. It is therefore obvious, that warm water will issue from an aperture with greater velocity than cold water, and that the quantities of fluid discharged from the same orifice, and under the same pressure, will increase with the temperature of the fluid. Hence we may discover the cause of the great discrepancy between the experiments of different philosophers on the motion of fluids.

(L) Ἐλευσίου γὰρ ἡ ψυχρότης τοῦ ὕδατος ποιεῖ βαρὺν καὶ σαρπητώδη, οἷον ἔστιν ἐν ταῖς κλεψυδραῖς καταράταις, βραδύον γὰρ ἵλασσι χυμῶσι ἢ θερμῶσι. *Aquam enim impellens frigus gravem facit et crassam, quod in clepsydriis licet observare: tardius enim trahunt hyeme quam aestate.* PLUTARCH, *Quest. Natural.*

On the Resistance of Fluids.

fluids. Their experiments were performed in different climates and at different seasons of the year; and, as the temperature of the water would be variable from these and from other causes, a variation in their results was the inevitable consequence.

Experiments for determining the effects of heat on the motion of fluids.

219. The writer of this article has a set of experiments in view, by which he expects to determine the precise effects of heat upon the motion of fluids, and to furnish the practical hydraulist with a more correct formula than that of the Chevalier Buat, for finding, under any given circumstances, the velocity of water and the quantities discharged. He hopes also to be able to determine whether or not the friction of water in conduit pipes varies, as in the case of solid bodies, with the nature of the substances of which the pipes are formed; and to ascertain the effects of different nungents in diminishing the resistance of friction. The result of these experiments will probably be communicated in a subsequent article of this work.

CHAP. III. On the Resistance of Fluids.

Reference to the article RESISTANCE of Fluids.

220. IN the article RESISTANCE of Fluids, the reader will find that important subject treated at great length, and with great ability, by the late learned Dr Robison. The researches of preceding philosophers are there given in full detail; their different theories are compared with experiments, and the defects of these minutely considered. Since that article was composed, this intricate subject has been investigated by other writers, and though they have not enriched the science of hydraulics with a legitimate theory of the resistance of fluids, the results of their labours cannot fail to be interesting to every philosopher.

Researches of Coulomb.

221. The celebrated Coulomb has very successfully employed the principle of torsion, to determine the cohesion of fluids, and the laws of their resistance in very slow motions. His experiments are new, and were performed with the greatest accuracy; and the results which he obtained were perfectly conformable to the deductions of theory. We shall therefore endeavour to give the reader some idea of the discoveries which he has made.

222. When a body is struck by a fluid with a velocity exceeding eight or nine inches per second, the resistance has been found proportional to the square of the velocity, whether the body in motion strikes the fluid at rest, or the body is struck by the moving fluid. But when the velocity is so slow as not to exceed four-tenths of an inch in a second, the resistance is represented by two terms, one of which is proportional to the simple velocity, and the other to the square of the velocity. The first of these sources of resistance arises from the cohesion of the fluid particles which separate from one another, the number of particles thus separated being proportional to the velocity of the body. The other cause of resistance is the inertia of the particles, which when struck by the fluid, acquire a certain degree of velocity proportional to the velocity of the body; and as the number of these particles is also proportional to that velocity, the resistance generated by their inertia must be proportional to the square of the velocity.

* Principia lib. ii. prop. xi.

223. When Sir Isaac Newton* was determining the resistance which the air opposed to the oscillatory motion of a globe in small oscillations, he employed a formula of

three terms, one of them being as the square of the velocity, the second the $\frac{1}{2}$ power of the velocity, and the third as the simple velocity; and in another part of the work he reduces the formula to two terms, one of which is as the square of the velocity, and the other constant. D. Bernouilli (*Comment. Petropol. tom. iii. Bernouilli, and Gravesende.*) also supposes the resistance to be represented by two terms, one as the square of the velocity, and the other constant. M. Gravesende (*Elements of Nat. Phil. art. 1911*), has found that the pressure of a fluid in motion against a body at rest, is partly proportional to the simple velocity, and partly to the square of the velocity. But when the body moves in a fluid at rest, he found (art. 1975) the resistance proportional to the square of the velocity, and to a constant quantity.—When the body in motion, therefore, meets the fluid at rest, these three philosophers have agreed, that the formula which represents the resistance of fluids consists of two terms, one of which is as the square of the velocity, and the other constant. The experiments of Coulomb, however, incontestably prove, that the pressure which the moving body in this case sustains, is represented by two terms, one proportional to the simple velocity, and the other to its square, and that if there is a constant quantity, it is so very small as to escape detection.

224. In order to apply the principle of torsion to the resistance of fluids, M. Coulomb made use of the apparatus represented in fig. 1. On the horizontal arm LK, which may be supported by a vertical stand, is fixed the small circle *f e*, perforated in the centre, so as to admit the cylindrical pin *b a*. Into a slit in the extremity of this pin is fastened, by means of a screw, the brass wire *a g*, whose force of torsion is to be compared with the resistance of the fluid; and its lower extremity is fixed in the same way into a cylinder of copper *g d*, whose diameter is about four-tenths of an inch. The cylinder *g d* is perpendicular to the disc DS, whose circumference is divided into 480 equal parts. When this horizontal disc is at rest, which happens when the torsion of the brass wire is nothing, the index RS is placed upon the point *o*, the zero of the circular scale. The small rule *R m* may be elevated or depressed at pleasure round its axis *n*, and the stand GH which supports it may be brought into any position round the horizontal disc. The lower extremity of the cylinder *g d* is immersed about two inches in the vessel of water MNOP, and to the extremity *d* is attached the planes, or the bodies whose resistance is to be determined when they oscillate in the fluid by the torsion of the brass wire. In order to produce these oscillations, the disc DS, supported by both hands, must be turned gently round to a certain distance from the index, without deranging the vertical position of the suspended wire. The disc is then left to itself; the force of torsion causes it to oscillate, and the successive diminutions of these oscillations are carefully observed. A simple formula gives in weights the force of torsion that produces the oscillations; and another formula well known to geometers, determines (by an approximation sufficiently accurate in practice), by means of the successive diminution of the oscillations compared with their amplitude, what is the law of the resistance, relative to the velocity, which produces these diminutions.

On the Resistance of Fluids. Opinions of Newton, Bernouilli, and Gravesende.

Apparatus employed in Coulomb's experiments.

Plate CCLXIX. fig. 1.

Method of using it.

Resistance Of Fluids.
 The method adopted by Coulomb resembles that employed by Newton and other philosophers who observed the oscillations of a pendulum in resisting media.
 Disadvantages of a pendulum.

225. The method employed by Coulomb, in reducing his experiments, is similar to that adopted by Newton and other mathematicians, when they wished to determine the resistance of fluids, from the successive diminutions of the oscillations of a pendulum moving in a resisting medium; but it is much better fitted for detecting the small quantities which are to be estimated in such researches. When the pendulum is employed, the specific gravity of the body, relative to that of the fluid, must be determined; and the least error in this point leads to very uncertain results. When the pendulum is in different points of the arc in which it oscillates, the wire or pendulum rod is plunged more or less in the fluid; and the alterations which may result from this are frequently more considerable than the small quantities which are the object of research. It is only in small oscillations, too, that the force which brings the pendulum from the vertical, is proportional to the angle which the pendulum rod, in different positions, forms with this vertical line; a condition which is necessary before the formulae can be applied. But small oscillations are attended with great disadvantages; and their successive diminutions cannot be determined but by quantities which it is difficult to estimate exactly, and which are changed by the smallest motion either of the fluid in the vessel, or of the air in the chamber. In small velocities, the pendulum rod experiences a greater resistance at the point of floatation than at any other part. This resistance, too, is very changeable; for the water rises from its level along the pendulum rod to greater or less heights, according to the velocity of the pendulum.

Advantages of comparing the resistance of fluids with the force of torsion.

226. These and other inconveniences which might be mentioned, are so inseparable from the use of the pendulum, that Newton and Bernouilli have not been able to determine the laws of the resistance of fluids in very slow motions. When the resistance of fluids is compared with the force of torsion, these disadvantages do not exist. The body is in this case entirely immersed in the fluid; and as every point of its surface oscillates in a horizontal plane, the relation between the densities of the fluid and the oscillating body has no influence whatever on the moving force. One or two circles of amplitude may be given to the oscillations; and their duration may be increased at pleasure, either by diminishing the diameter of the wire, or increasing its length; or, which may be more convenient, by augmenting the momentum of the horizontal disc. Coulomb, however, found that when each oscillation was so long as to continue about 100 seconds, the least motion of the fluid, or the tremor occasioned by the passing of a carriage, produced a sensible alteration on the results. The oscillations best fitted for experiments of this kind, continued from 20 to 30 seconds, and the amplitude of those that gave the most regular results, was comprehended between 480 degrees, the entire division of the disc, and 8 or 10 divisions reckoned from the zero of the scale. From these observations it will be readily seen, that it is only in very slow motions that an oscillating body can be employed for determining the resistance of fluids. In small oscillations, or in quick circular motions, the fluid struck by the body is continually in motion; and when the oscillating body returns to its former position, its velocity is either increased or

retarded by the motion communicated to the fluid, and not extinguished.

Resistance Of Fluids.
 On the Resistance of Fluids.
 When the velocity is very small, the part of the resistance proportional to the square of the velocity, wholly disappeared. For if, in any particular case, the portion of the resistance proportional to the square of the velocity, should be equal to the portion that is proportional to the square of the velocity when the body has a velocity of one-tenth of an inch per second; then, when the velocity is 100 tenths of an inch per second, the part proportional to the square of the velocity will be a hundred times greater than that proportional to the simple velocity; but if the velocity is only the 100th part of the tenth of an inch per second, then the part proportional to the simple velocity will be 100 times greater than the part proportional to the square of the velocity.

227. In the first set of experiments made by Coulomb, he attached to the lower extremity of the cylinder *g d* a circular plate of white iron, about 195 millimetres in diameter, and made it move so slowly, that the part of the resistance proportional to the square of the velocity, wholly disappeared. For if, in any particular case, the portion of the resistance proportional to the square of the velocity, should be equal to the portion that is proportional to the square of the velocity when the body has a velocity of one-tenth of an inch per second; then, when the velocity is 100 tenths of an inch per second, the part proportional to the square of the velocity will be a hundred times greater than that proportional to the simple velocity; but if the velocity is only the 100th part of the tenth of an inch per second, then the part proportional to the simple velocity will be 100 times greater than the part proportional to the square of the velocity.

228. When the oscillations of the white iron plate were so slow, that the part of the resistance which varies with the second power of the velocity was greatly inferior to the other part, he found, from a variety of experiments, that the resistance which diminished the oscillations of the horizontal plate was uniformly proportional to the simple velocity, and that the other part of the resistance, which follows the ratio of the square of the velocity, produced no sensible change upon the motion of the white iron disc.—He found also, in conformity with theory, that the momenta of resistance in different circular plates moving round their centre in a fluid, are as the fourth power of the diameters of these circles; and that, when a circle of 195 millimetres (6.677 English inches) in diameter, moved round its centre in water, so that its circumference had a velocity of 140 millimetres (5.512 English inches) per second, the momentum of resistance which the fluid opposed to its circular motion was equal to one-tenth of a gramme (1.544 English troy grains) placed at the end of a lever 143 millimetres (5.63 English inches) in length.

Result of Coulomb's experiments on the resistance of water to a horizontal plate moving round its centre in its superficies.

229. M. Coulomb repeated the same experiments in a vessel of clarified oil, at the temperature of 16 degrees of Reaumur. He found, as before, that the momenta of the resistance of different circles, moving round their centre in the plane of their superficies, were as the fourth power of their diameters; and that the difficulty with which the same horizontal plate, moving with the same velocity, separated the particles of oil, was to the difficulty with which it separated the particles of water, as 17.5 to 1, which is therefore the ratio that the mutual cohesion of the particles of oil has to the mutual cohesion of the particles of water.

Similar result obtained in clarified oil.
 Ratio between the mutual cohesion of the particles of oil, and the mutual cohesion of the particles of water.

230. In order to ascertain whether or not the resistance of a body moving in a fluid was influenced by the nature of its surface, M. Coulomb anointed the surface of the white iron plate with tallow, and wiped it partly away, so that the thickness of the plate might not be sensibly increased. The plate was then made to oscillate in water, and the oscillations were found to diminish in the same manner as before the application of the unguent. Over the surface of the tallow upon the plate, he afterwards scattered, by means of a sieve, a quantity

The resistance not influenced by the nature of the surface of the moving body.

On the Resistance of Fluids.

quantity of coarse sand which adhered to the greasy surface; but when the plate, thus prepared, was caused to oscillate, the augmentation of resistance was so small, that it could scarcely be appreciated. We may therefore conclude, that the part of the resistance which is proportional to the simple velocity, is owing to the mutual adhesion of the particles of the fluid, and not to the adhesion of these particles to the surface of the body.

Experiments for finding if the resistance is increased by increasing the superincumbent fluid.

231. If the part of the resistance varying with the simple velocity were increased when the white iron plate was immersed at greater depths in the water, we might suppose it to be owing to the friction of the water on the horizontal surface, which, like the friction of solid bodies, should be proportional to the superincumbent pressure. In order to settle this point, M. Coulomb made the white iron plate oscillate at the depth of two centimetres (.787 English inches), and also at the depth of 50 centimetres (19.6855 English inches), and found no difference in the resistance; but as the surface of the water was loaded with the whole weight of the atmosphere, and as an additional load of 50 centimetres of water could scarcely produce a perceptible augmentation of the resistance, M. Coulomb employed another method of deciding the question. Having placed a vessel full of water under the receiver of an air-pump, the receiver being furnished with a rod and collar of leather at its top, he fixed to the hook, at the end of the rod, a harpichord wire, numbered 7 in commerce, and suspended to it a cylinder of copper, like *gd*, fig. 1. which plunged in the water of the vessel, and under this cylinder he fixed a circular plane, whose diameter was 101 millimetres (3.976 English inches). When the oscillations were finished, and consequently the force of torsion nothing, the zero of torsion was marked by the aid of an index fixed to the cylinder. The rod was then made to turn quickly round through a complete circle, which gave to the wire a complete circle of torsion, and the successive diminutions of the oscillations were carefully observed. The diminution for a complete circle of torsion was found to be nearly a fourth part of the circle for the first oscillation, but always the same whether the experiment was made in a vacuum or in the atmosphere. A small pallet 50 millimetres long (1.969 English inches) and 10 millimetres broad, (0.3937 English inches) which struck the water perpendicular to its plane, furnished a similar result. We may therefore conclude, that when a submerged body moves in a fluid, the pressure which it sustains, measured by the altitude of the superior fluid, does not perceptibly increase the resistance; and consequently, that the part of this resistance proportional to the simple velocity, can in no respect be compared with the friction of solid bodies, which is always proportional to the pressure.

On the resistance of cylinders moving perpendicular to their axes.

232. The next object of M. Coulomb was to ascertain the resistance experienced by cylinders that moved very slowly, and perpendicular to their axes; but as the particles of fluid struck by the cylinder necessarily partook of its motion, it was impossible to neglect the part of the resistance proportional to the square of the velocity, and therefore he was obliged to perform the experiments in such a manner that both parts of the resistance might be computed. The three cylinders which he employed were 249 millimetres (.9803 English inches) long. The first cylinder was 0,87 millimetres (0.0342 English inches or $\frac{1}{29}$ of an inch) in

circumference, the second 11.2 millimetres (0.4409 English inches), and the third 21.1 millimetres (.8307 English inches). They were fixed by their middle under the cylindrical piece *dg*, so as to form two horizontal radii, whose length was 124.5 millimetres (.4901 English inches) or half the length of each cylinder. After making the necessary experiments and computations, he found that the part of the resistance proportional to the simple velocity, which, to avoid circumlocution we shall call *r*, did not vary with the circumferences of the cylinders. The circumferences of the first and third cylinders were to one another as 24 : 1, whereas the resistances were in the ratio of 3 : 1. The same conclusion was deduced by comparing the experiments made with the first and second cylinder.

233. In order to explain these results, M. Coulomb very justly supposes, that in consequence of the mutual adhesion of the particles of water, the motion of the cylinder is communicated to the particles at a small distance from it. The particles which touch the cylinder have the same velocity as the cylinder, those at a greater distance have a less velocity, and at the distance of about one-tenth of an inch the velocity ceases entirely, so that it is only at that distance from the cylinder that the mutual adhesion of the fluid molecules ceases to influence the resistance. The resistance *r* therefore should not be proportional to the circumference of the real cylinder, but to the circumference of a cylinder whose radius is greater than the real cylinder by one-tenth of an inch. It consequently becomes a matter of importance to determine with accuracy the quantity which must be added to the real cylinder in order to have the radius of the cylinder to which the resistance *r* is proportional, and from which it must be computed. Coulomb found the quantity by which the radius should be increased, to be 1.5 millimetres ($\frac{1}{66}$ of an English inch) so that the diameter of the augmented cylinder will exceed the diameter of the real cylinder by double that quantity, or $\frac{1}{33}$ of an inch.

234. The part of the resistance varying with the square of the velocity, or that arising from the inertia of the fluid, which we shall call *R*, was likewise not proportional to the circumferences of the cylinder; but the augmentation of the radii amounts in this case only to $\frac{1}{55}$ of an inch, which is only one-fifth of the augmentation necessary for finding the resistance *r*. The reason of this difference is obvious; all the particles of the fluid when they are separated from each other oppose the same resistance, whatever be their velocity; consequently as the value of *r* depends only on the adhesion of the particles, the resistances due to this adhesion will reach to the distance from the cylinder of an inch where the velocity of the particles is 0. In comparing the different values of *R*, the part of the resistance which varies as the square of the velocity, all the particles are supposed to have a velocity equal to that of the cylinder; but as it is only the particles which touch the cylinder that have this velocity, it follows that the augmentation of the diameter necessary for finding *R* must be less than the augmentation necessary for finding *r*.

235. In determining experimentally the part of the momentum of resistance proportional to the velocity, by two cylinders of the same diameter, but of different lengths, M. Coulomb found that this momentum was proportional

On the Resistance of Fluids. proportional to the third power of their lengths. The same result may be deduced from theory; for supposing each cylinder divided into any number of parts, the length of each part will be proportional to the whole length. The velocity of the corresponding parts will be as these lengths, and also as the distance of the same parts from the centre of rotation. The theory likewise proves, that the momentum of resistance depending on the square of the velocity, in two cylinders of the same diameter but of different lengths, is proportional to the fourth power of the length of the cylinder.

236. When the cylinder 0.9803 inches in length, and 0.04409 inches in circumference, was made to oscillate in the fluid with a velocity of 5.51 inches per second, the part of the resistance *r* was equal to 58 milligrammes, or .8932 troy grains. And when the velocity was 0.3937 inches per second, the resistance *r* was 0.00414 grammes, or 0.637 troy grains.

237. The preceding experiments were also made in the oil formerly mentioned; and it likewise appeared, from their results, that the mutual adhesion of the particles of oil was to the mutual adhesion of the particles of water as 17 to 1. But though this be the case, M. Coulomb discovered that the quantity by which the radii of the cylinder must be augmented in order to have the resistance *r*, is the very same as when the cylinder oscillated in water. This result was very unexpected, as the greater adhesion between the particles of oil might have led us to anticipate a much greater augmentation. When the cylinders oscillated both in oil and water with the same velocity, the part of the resistance *R* produced by the inertia of the fluid particles which the cylinder put in motion, was almost

the same in both. As this part of the resistance depends on the quantity of particles put in motion, and not on their adhesion, the resistances due to the inertia of the particles will be in different fluids as their densities.

238. In a subsequent memoir Coulomb proposes to determine numerically the part of the resistance proportional to the square of the velocity, and to ascertain the resistance of globes with plain, convex, and concave surfaces. He has found in general that the resistance of bodies not entirely immersed in the fluid is much greater than that of bodies which are wholly immersed; and he promises to make farther experiments upon this point. We intended on the present occasion to have given the reader a more complete view of the researches of this ingenious philosopher; but these could not well be understood without a knowledge of his investigations respecting the force of torsion, which we have not yet had an opportunity of communicating. In the article MECHANICS, however, we shall introduce the reader to this interesting subject; and may afterwards have an opportunity of making him farther acquainted with those researches of Coulomb, of which we have at present given only a general view.

239. The subject of the resistance of fluids has been recently treated by the learned Dr Hutton of Woolwich. His experiments were made in air, with bodies of various forms, moving with different velocities, and inclined at various angles to the direction of their motion. The following table contains the results of many interesting experiments. The numbers in the 9th column represent the exponents of the power of the velocity which the resistances in the 8th column bear to each other.

TABLE I. Shewing the Resistance of Hemispheres, Cones, Cylinders, and Globes, in different Positions, and moving with different Velocities.

Velocity per second.	Small hemisphere, 4 1/2 inches dia. flat side.	Large hemisphere 6 1/2 inches diameter.		Cone 6 1/2 inches diameter.		Cylinder 6 1/2 inches diameter.	Globe 6 1/2 inches diameter.	Power of the vel. to which the resistance is proportional.
		Flat side.	Round side.	Vertex.	Base.			
Feet.	Ounces av.	Ounces av.	Ounces av.	Ounces av.	Ounces av.	Ounces av.	Ounces av.	
3	.028	.051	.020	.028	.064	.050	.027	
4	.048	.096	.039	.048	.109	.090	.047	
5	.072	.148	.063	.071	.162	.143	.068	
6	.103	.211	.092	.098	.225	.205	.094	
7	.141	.284	.123	.129	.298	.278	.125	
8	.184	.368	.160	.168	.382	.360	.162	
9	.233	.464	.199	.211	.478	.456	.205	
10	.287	.573	.242	.260	.587	.565	.255	
11	.349	.698	.292	.315	.712	.688	.310	2.052
12	.418	.836	.347	.376	.850	.826	.370	2.042
13	.492	.988	.409	.440	1.000	.979	.435	2.036
14	.573	1.154	.478	.512	1.166	1.145	.505	2.031
15	.661	1.336	.552	.589	1.346	1.327	.581	2.032
16	.754	1.538	.634	.673	1.546	1.526	.663	2.033
17	.853	1.757	.722	.762	1.763	1.745	.752	2.038
18	.959	1.928	.818	.858	2.002	1.986	.848	2.044
19	1.073	2.998	.921	.959	2.260	2.246	.949	2.047
20	1.196	2.542	1.033	1.069	2.540	2.528	1.057	2.051
Mean proportional numbers.	140	288	119	126	291	285	124	2.040
1	2	3	4	5	6	7	8	9

On the Resistance of Fluids. Results of the preceding experiments.

240. From the preceding experiments we may draw the following conclusions: 1. That the resistance is nearly proportional to the surfaces, a small increase taking place when the surfaces and the velocities are great. 2. The resistance to the same surface moving with different velocities, is nearly as the square of the velocity; but it appears from the 9th column that the exponent increases with the velocity. 3. The round and sharp ends of solids sustain a greater resistance than the flat ends of the same diameter. 4. The resistance to the base of the hemisphere is to the resistance on the convex side, or the whole sphere, as $2\frac{1}{2}$ to 1, instead of 2 to 1, as given by theory. 5. The resistance on the base of the cone is to the resistance on the vertex nearly as $2\frac{1}{2}$ to 1; and in the same ratio is radius to the sine of half the angle at the vertex. Hence in this case the resistance is directly as the sine of the angle of incidence, the transverse section being the same. 6. The resistance of the base of a hemisphere, the base of a cone, and the base of a cylinder, are all different, though these bases be exactly equal and similar.

241. The following table contains the resistance sustained by a globe 1.965 inches in diameter. The fourth column is the quotient of the resistance by experiment, divided by the theoretical resistance.

Experiments with a globe 1.965 inches in diameter.

TABLE II. Containing the Resistance to a Globe 1.965 Inches in Diameter, moving with various Velocities, according to Theory and Experiment.

Velocity of the Globe per second.	Resistance by experiment.	Resistance by theory	Ratio between the experimental and theoretical resistances.	Power of the velocity to which the resistance is proportional.
Fect.	Oz. avoird.	Oz. avoird.		
5	0.006	0.005	1.20	
10	0.0245	0.020	1.23	
15	0.055	0.044	1.25	
20	0.100	0.079	1.27	
25	0.157	0.123	1.28	2.022
30	0.23	0.177	1.30	2.059
40	0.42	0.314	1.33	2.068
50	0.67	0.491	1.36	2.075
100	2.72	1.964	1.38	2.059
200	11	7.9	1.40	2.041
300	25	18.7	1.41	2.039
400	45	31.4	1.43	2.039
500	72	49	1.47	2.044
600	107	71	1.51	2.051
700	151	96	1.57	2.059
800	205	126	1.63	2.067
900	271	159	1.70	2.077
1000	350	196	1.78	2.086
1100	442	238	1.86	2.095
1200	546	283	1.90	2.102
1300	661	332	1.99	2.107
1400	785	385	2.04	2.111
1500	916	442	2.07	2.113
1600	1051	503	2.09	2.113
1700	1186	568	2.08	2.111
1800	1319	636	2.07	2.108
1900	1447	709	2.04	2.104
2000	1569	786	2.00	2.098
1	2	3	4	5

242. It appears from a comparison of the 2d, 3d, and 4th columns, that when the velocity is small the resistance by experiment is nearly equal to that deduced from theory; but that as the velocity increases, the former gradually exceeds the latter till the velocity is 1300 feet per second, when it becomes twice as great. The difference between the two resistances then increases, and reaches its maximum between the velocities of 1600 and 1700 feet. It afterwards decreases gradually as the velocity increases, and at the velocity of 2000 the resistance by experiment is again double of the theoretical resistance.—By considering the numbers in column 5th it will be seen, that in slow motions the resistances are nearly as the squares of the velocities; that this ratio increases gradually, though not regularly, till at the velocity of 1500 or 1600 feet it arrives at its maximum. It then gradually diminishes as the velocity increases.

Conclusions similar to these were deduced from experiments made with globes of a larger size.

243. The following table contains the resistance of a plane inclined at various angles, according to experiment, and according to a formula deduced from the experiments.

TABLE III. Containing the Resistances to a Plane inclined at various Angles to the Line of its Motion.

Inclination of the plane	Resistances by experiment	Resistances by the formula $0.84s^2 \cdot \sin^2 c$.	Sines of the angles to radius .840.
Degrees.	Oz. avoird.	Oz. avoird.	
0	.000	.000	.000
5	.015	.009	.073
10	.044	.035	.146
15	.082	.076	.217
20	.133	.131	.287
25	.200	.190	.355
30	.278	.278	.420
35	.362	.363	.482
40	.448	.450	.540
45	.534	.535	.594
50	.619	.613	.643
55	.684	.680	.688
60	.729	.736	.727
65	.770	.778	.761
70	.803	.808	.789
75	.823	.826	.811
80	.835	.836	.827
85	.839	.839	.838
90	.840	.840	.840
1	2	3	4

244. The plane with which the preceding experiments were performed was 32 square inches, and always moved with a velocity of 12 feet per second. The resistances which this plane experienced are contained in column 2d. From the numbers in that column Dr Hutton deduced the formula $.84s^2 \cdot \sin^2 c$, where s is the sine, and c is the cosine of the angles of inclination in the first column. The resistances computed from this formula are contained in column 3d, and agree very nearly

ly with the resistances deduced from experiment. The 4th column contains the sines of the angles in the first column to a radius .84, in order to compare them with the resistances which have obviously no relation either to the sines of the angles or to any power of the sines. From the angle of 0 to about 60° the resistances are less than the sines; but from 60° to 90° they are somewhat greater.

245. The experiments of Mr Vince were made with bodies at a considerable depth below the surface of water; and he determined the resistance which they experienced, both when they moved in the fluid at rest, and when they received the impulse of the moving fluid. In the experiments contained in the following table, the body moved in the fluid with a velocity of 0.66 feet in a second. The angles at which the planes struck the fluid are contained in the first column. The second column shews the resistance by experiment in the direction of their motion in troy ounces. The third column exhibits the resistances by theory, the perpendicular distance being supposed the same as by experiment. The fourth column shews the power of the sine of the angle to which the resistance is proportional, and was computed in the following manner. Let o be the sine of the angle, radius being 1, and r the resistance at that angle. Suppose r to vary as s^m , then we have $r^m : s^m = 0.2321 : r$; hence $s^m = \frac{r}{0.2321}$, and therefore $m = \frac{\text{Log. } r - \text{Log. } 0.2321}{\text{Log. } s}$, and by substituting their corresponding values, instead of r and s we shall have the values of m or the numbers in the fourth column.

TABLE IV. Containing the Resistance of a Plane Surface moving in a Fluid, and placed at different Angles to the Path of its Motion.

Angle of inclination.	Resistance by experiment.	Resistance by theory.	Power of the sine of the angle to which the resistance is proportional.
Degrees.	Troy ounces.	Troy ounces.	Exponents.
10	0.0112	0.0012	1.73
20	0.0364	0.0093	1.73
30	0.0769	0.0290	1.54
40	0.1174	0.0616	1.54
50	0.1552	0.1043	1.51
60	0.1902	0.1476	1.38
70	0.2125	0.1926	1.42
80	0.2237	0.2217	2.41
90	0.2321	0.2321	
I	2	3	4

246. According to the theory the resistance should vary as the cube of the sine, whereas from an angle of 90° it decreases in a less ratio, but not as any constant power, nor as any function of the sine and cosine. Hence the actual resistance always exceeds that which is deduced from theory, assuming the perpendicular resistance to be the same. The cause of this difference is partly owing

to our theory neglecting that part of the force which after resolution acts parallel to the plane, but which according to experiments is really a part of the force which acts upon the plane.

247. Mr Vince made also a number of experiments on the resistance of hemispheres, globes, and cylinders, which moved with a velocity of 0.542 feet per second. He found that the resistance to the spherical side of a hemisphere was to the resistance on its base as 0.034 is to 0.08339; that the resistance of the flat side of a hemisphere was to the resistance of a cylinder of the same diameter, and moving with the same velocity, as 0.08339 is to 0.07998; and that the resistance to a complete globe is to the resistance of a cylinder of the same diameter, and with the same velocity, as 1 : 2.23.

248. The following results were obtained, when the plane was struck by the moving fluid. The 2d column of the following table contains the resistance by experiment, and the 3d column the resistance by theory from the perpendicular force, supposing it to vary as the sine of the inclination.

TABLE V. Containing the Resistance of a Plane struck by the Fluid in Motion, and inclined at different Angles to the direction of its Path.

Angle of inclination.	Resistance by experiment.	Resistance by theory.
Degrees.	Oz. dwts. grs.	Oz. dwts. grs.
90	1 17 12	1 17 12
80	1 17 0	1 16 22
70	1 15 12	1 15 .6
60	1 12 12	1 12 11
50	1 18 10	1 18 17
40	1 4 10	1 4 2
30	0 18 18	0 18 18
20	0 12 12	0 12 19
10	0 6 4	0 6 12
I	2	3

249. It appears from the preceding results, that the resistance varies as the sine of the angle at which the fluid strikes the plane, the difference between theory and experiment being such as might be expected from the necessary inaccuracy of the experiments.

By comparing the preceding table with Table IV. it will be found that the resistance of a plane moving in a fluid is to the resistance of the same plane when struck by the fluid in motion as 5 to 6. In both these cases the actual effect on the plane must be the same, and therefore the difference in the resistance can arise only from the action of the fluid behind the body in the former case.

CHAP. IV. On the Oscillation of Fluids, and the Undulation of Waves.

PROP. I.

250. The oscillations of water in a syphon, consisting of two vertical branches and a horizontal one, are isochronous, and have the same duration.

Oscillation of Fluids, &c.

Plate GCLXIX. Fig. 2.

tion as the oscillations of a pendulum, whose length is equal to half the length of the oscillating column of water.

Into the tube MNOP, having its internal diameter everywhere the same, introduce a quantity of water. When the water is in equilibrio, the two surfaces AB, CD will be in the same horizontal line AD. If this equilibrium be disturbed by making the syphon oscillate round the point *z*, the water will rise and fall alternately in the vertical branches after the syphon is at rest. Suppose the water to rise to EF in the branch MO, it will evidently fall to GH in the other branch, so that CG is equal to AE. Then it is evident, that the force which makes the water oscillate, is the weight of the column EFKL, which is double the column EABF; and that this force is to the whole weight of the water, as 2AE is to AOPD. Now, let P be a pendulum, whose length is equal to half the length of the oscillating column AOPD, and which describes to the lowest point S arches PS, equal to AE; then 2AE : AOPD = AE : QP, because AE is one-half of 2AE, and QP one-half of AOPD. Consequently, since AOPD is a constant quantity, the force which makes the water oscillate is always proportional to the space which it runs through, and its oscillations are therefore isochronous. The force which makes the pendulum describe the arch PS, is to the weight of the pendulum as PS is to PQ, or as AE is to PQ, since AE = PS; but the force which makes the water oscillate, is to the weight of the whole water in the same ratio; consequently, since the pendulum P, and the column AOPD, are influenced by the very same force, their oscillations must be performed in the same time. Q. E. D.

Fig. 3.

251. COR. As the oscillations of water and of pendulums are regulated by the same laws, if the oscillating column of water is increased or diminished, the time in which the oscillations are performed will increase or diminish in the subduplicate ratio of the length of the pendulum.

SCHOLIUM.

252. This subject has been treated in a general manner, by Newton and different philosophers, who have shewn how to determine the time of an oscillation, whatever be the form of the syphon. See the *Principia*, lib. ii. Prop. 45, 46. Bossut's *Traité d'Hydrodynamique*, tom. i. *Notes sur le Chap. II. Part II. Bernouilli Opera*, tom. iii. p. 125. and *Encyclopedie*, art. *Ondes*.

PROP. II.

253. The undulations of waves are performed in the same time as the oscillations of a pendulum whose length is equal to the breadth of a wave, or to the distance between two neighbouring cavities or eminences.

On the undulation of waves.

Fig. 4.

In the waves ABCDEF, the undulations are performed in such a manner, that the highest parts A, C, E become the lowest; and as the force which

depresses the eminences A, C, E, is always the weight of water contained in these eminences, it is obvious, that the undulations of waves are of the same kind as the undulations or oscillations of water in a syphon. It follows, therefore, from Prop. I. that if we take a pendulum, whose length is one-half BM, or half the distance between the highest and lowest parts of the wave, the highest parts of each wave will descend to the lowest parts during one oscillation of the pendulum, and in the time of another oscillation will again become the highest parts. The pendulum, therefore, will perform two oscillations in the time that each wave performs one undulation, that is, in the time that each wave describes the space AC or BD, between two neighbouring eminences or cavities, which is called the breadth of the wave. Now if a pendulum, whose length is one-half BM, performs two oscillations in the above time, it will require a pendulum four times that length to perform only one oscillation in the same time, that is, a pendulum whose length is AC or BD, since $4 \times \frac{1}{2} BM = 2 BM = AC$ or BD. Q. E. D.

Oscillation of Fluids, &c.

SCHOLIUM.

254. The explanation of the oscillation of waves contained in the two preceding propositions, was first given by Sir Isaac Newton, in his *Principia*, lib. ii. Prop. 44. He considered it only as an approximation to the truth, since it supposes the waves to rise and fall perpendicularly like the water in the vertical branches of the syphon, while their real motion is partly circular. The theory of Newton was, nevertheless, adopted by succeeding philosophers, and gave rise to many analogous discussions respecting the undulation of waves. Very lately, however, an attempt has been made by M. Flaugergues, to overturn the theory of Newton. From a number of experiments on the motion and figure of waves, an account of which may be seen in the *Journal des Sçavans*, for October 1789, M. Flaugergues concludes, that a wave is not the result of a motion in the particles of water, by which they ascend and descend alternately in a serpentine line, when moving from the place where the water received the shock; but that it is an intumescence which this shock occasions around the place where it is received, by the depression that is there produced. This intumescence afterwards propagates itself circularly, while it removes from the place where the shock first raised it above the level of the stagnant water. A portion of the stagnant water then flows from all sides into the hollow formed at the place where the shock was received; this hollow is thus heaped with fluid, and the water is elevated so as to produce all around another intumescence, or a new wave, which propagates itself circularly as before. The repetition of this effect produces on the surface of the water a number of concentric rings, successively elevated and depressed, which have the appearance of an undulatory motion. This interesting subject has also been discussed by M. La Grange, in his *Mechanique Analytique*, to which we must refer the reader for farther information. See also some excellent remarks on this subject, in Mr Leslie's *Essay on Heat*, p. 223. and note 29.

PART III. ON HYDRAULIC MACHINERY.

Hydraulic machines. 255. TO describe the various machines in which water is the impelling power, would be an endless and unprofitable task. Those machines which can be driven by wind, steam, and the force of men or horses, as well as they can be driven by water, do not properly belong to the science of hydraulics. By hydraulic machinery, therefore, we are to understand those various contrivances by which water can be employed as the impelling power of machinery; and those machines which are employed to raise water, or which could not operate without the assistance of that fluid.

CHAP. I. On Water-Wheels.

Different kinds of water-wheels. 256. WATER-WHEELS are divided into three kinds, overshot-wheels, breast-wheels, and undershot-wheels, which derive their names from the manner in which the water is delivered upon their circumferences.

SECT. I. On Overshot-Wheels.

Description of an overshot-wheel. 257. An overshot-wheel is a wheel driven by the weight of water, conveyed into buckets disposed on its circumference. It is represented in fig. 5. where ABC is the circumference of the wheel furnished with a number of buckets. The canal MN conveys the water into the second bucket from the top Aa. The equilibrium of the wheel is therefore destroyed; and the power of the bucket Aa, to turn the wheel round its centre of motion O, is the same as if the weight of the water in the bucket were suspended at m, the extremity of the lever Om, c being the centre of gravity of the bucket, and Om a perpendicular let fall from the fulcrum O to the direction cm; in which the force is exerted. In consequence of this destruction of equilibrium, the wheel will move round in the direction AB, the bucket Aa will be at d, and the empty bucket b will take the place of Aa, and receive water from the spout N. The force acting on the wheel is now the water in the bucket d acting with a lever dO, and the water in the bucket Aa acting with a lever mO. The velocity of the wheel will therefore increase with the number of loaded buckets, and with their distance from the vertex of the wheel; for the lever by which they tend to turn the wheel about its axis, increases as the buckets approach to c, where their power, represented by cO, is a maximum. After the buckets have passed c, the lever by which they act gradually diminishes, they lose by degrees a small portion of their water; and as soon as they reach B it is completely discharged. When the wheel begins to move, its velocity will increase rapidly till the quadrant of buckets bc is completely filled. While these buckets are descending through the inferior quadrant eP, and the buckets on the left hand of b are receiving water from the spout, the velocity of the wheel will still increase; but the increments of velocity will be smaller and smaller, since the levers by which the inferior buckets act are gradually diminishing. As soon as the highest bucket Ac has reached the point B where it is emptied, the whole se-

micircumference nearly of the wheel is loaded with water; and when the bucket at B is discharging its contents, the bucket at A is filling, so that the load in the buckets, by which the wheel is impelled, will be always the same, and the velocity of the wheel will become uniform.

258. In order to find the power of the loaded arch Method of to turn the wheel, or, which is the same thing, to find computing a weight which suspended at the opposite extremity C, the moment of will balance the loaded arch or keep it in equilibrio, the water we must multiply the weight of water in each bucket, the water by the length of the virtual lever by which it acts, ed arch.

and take the sum of all these momenta for the momentum of the loaded arch. It will be much easier, however, and the result will be the same, if we multiply the weight of all the water on the arch AB, by the distance of its centre of gravity G, from the fulcrum or centre of motion O. Now, by the property of the centre of gravity (see MECHANICS), the distance of the centre of gravity of a circular arch from its centre, is a fourth proportional to half the arch, the radius, and the sine of half the arch. Since the vertical bucket b has no power to turn the wheel if it were filled, and since two or three buckets between B and P are always empty, we may safely suppose that the loaded arch never exceeds 160°, so that if R = radius of the wheel in feet, we shall have the length of half the loaded arch, or 80° = $2R \times 3.1416 \times \frac{1}{2} \times \frac{80}{90} = R \times 1.396$; and the distance of the centre of gravity from the fulcrum O, = GO = $R \times \text{Sin. } 80^\circ$.

Now, if N be the number of buckets in the wheel $\frac{160 N}{360}$, or $\frac{4 N}{9}$, will be the number of buckets in the loaded arch; and if G be the number of ale gallons contained in each bucket, the weight of the water in each bucket will be 1.02 X G pounds avoirdupois. The weight of the water, therefore, in the loaded arch, will be $\frac{4 N}{9} \times 10.2 G$, and consequently the momentum of the loaded arch will be = $\frac{4 N}{9} \times 10.2 G \times \frac{R \times \text{Sin. } 80^\circ}{R \times 1.396} = \frac{4 N}{9} \times 10.2 G \times 0.6338 = \frac{4 N}{9} \times 6.465 G$ pounds avoirdupois. Hence, we

have the following rule: Multiply the constant number 6.465 by $\frac{1}{3}$ of the number of buckets in the wheel, and this product by the number of ale gallons in each bucket; and the result will be the effective weight, or momentum of the water in the loaded arch. For a description of the best form that can be given to the buckets, see the article WATER-Works. Dr Robison has there recommended a mode of constructing the buckets invented by Mr Burns, who divided each bucket into two by means of a partition; but the writer of this article is assured, on the authority of an ingenious millwright, who wrought with Mr Burns at the time when wheels of this kind were constructed, that the inner bucket is never filled with water, and that much of the power is thus lost. The partition prevents the

On Water-Wheels. introduction of the fluid, and the water is driven backwards by the escape of the included air.

259. In the construction of overshot-wheels, it is of great importance to determine what should be the diameter of the wheel relatively to the height of the fall. It is evident that its diameter cannot exceed the height of the fall. Some mechanical writers have demonstrated that, in theory, an overshot-wheel will produce a maximum effect when its diameter is two-thirds of that height, the water being supposed to fall into the buckets with the velocity of the wheel. But this rule is palpably erroneous, and directly repugnant to the results of experiment. For if the height of the fall be 48 feet, the diameter of the wheel will, according to this rule, be 32 feet; and the water having to fall through 16 feet before it reaches the buckets, will have a velocity of 32 feet per second, which, according to the hypothesis, must also be the velocity of the wheel's circumference. But Smeaton has proved, that a maximum effect is produced by an overshot-wheel of any diameter, when its velocity is only *three* feet per second. The chevalier de Borda has shewn, that overshot-wheels will produce a maximum effect when their diameter is equal to the height of the fall; and this is completely confirmed by Mr Smeaton's experiments. From a great number of trials, Mr Smeaton has concluded, "that the higher the wheel is in proportion to the whole descent, the greater will be the effect." Nor is it difficult to assign the reason of this. The water which is conveyed into the buckets can produce very little effect by its impulse, even if its velocity be great; both on account of the obliquity with which it strikes the buckets, and in consequence of the loss of water occasioned by a considerable quantity of the fluid being dashed over their sides. Instead, therefore, of expecting an increase of effect from the impulse of the water occasioned by its fall through one-third of the whole height, we should allow it to act through this height by its gravity, and therefore make the diameter of the wheel as great as possible. But a disadvantage attends even this rule; for if the water is conveyed into the buckets without any velocity, which must be the case when the diameter of the wheel equals the height of the fall, the velocity of the wheel will be retarded by the impulse of the buckets against the water, and much power would be lost by the water dashing over them. In order, therefore, to avoid all inconveniences, the distance of the spout from the receiving bucket should, in general, be about two or three inches, that the water may be delivered with a velocity a little greater than that of the wheel; or, in other words, the diameter of an overshot-wheel should be two or three inches less than the greatest height of the fall; and yet it is no uncommon thing to see the diameters of these wheels scarcely one-half of that height. In such a construction the loss of power is prodigious.

On the proper velocity of overshot-wheels. 260. The proper velocity of overshot-wheels is a subject on which mechanical writers have entertained different sentiments. While some have maintained that there is a certain velocity which produces a maximum effect, Deparcieux has endeavoured to prove by a set of ingenious experiments that most work is performed by an overshot-wheel when it moves slowly, and that the more its motion is retarded by increasing the work to be performed, the greater will be the performance

of the wheel. In these experiments he employed a small wheel, 20 inches in diameter, having its circumference furnished with 48 buckets. On the centre or axle of this wheel were placed 4 cylinders of different diameters, the first being 1 inch in diameter, the second 2 inches, the third 3 inches, and the fourth 4 inches. When the experiments are made, a cord is attached to one of the cylinders, and after passing over a pulley a weight is suspended at its other extremity. By moving the wheel upon its axis, the cord winds round the cylinder and raises the weight. In order to diminish the friction, the gudgeons of the wheel are supported by two friction rollers, and before the wheel, a little higher than its axis, is placed a small table which supports a vessel filled with water, having an orifice in the side next the wheel. Above this vessel is placed a large bottle full of water and inverted, having its mouth immersed a few lines in the water, so that it empties itself in proportion as the water in the vessel is discharged from the orifice. The quantity of water thus discharged is always the same, and is conveyed from the orifice by means of a canal to the buckets of the wheel. With this apparatus he obtained the following results.

Diameters of the Cylinders.	Altitude through which 12 ounces were elevated.	Altitude through which 24 ounces were elevated.
Inches.	Inches. Lines.	Inches. Lines.
1	69 9	40 0
2	80 6	43 6
3	85 6	44 6
4	87 9	45 3

261. When the large cylinders were used, the velocity of the wheel was smaller, because the resistances are proportional to their diameter, the weight being the same. Hence, it appears, by comparing the four results in column 2d with one another, and also the four results in column 3d, that when the wheel turns more slowly, the effect, which is in this case measured by the elevation of the weight, always increases. When the weight of 24 ounces was used, the resistance was twice as great, and the velocity twice as slow, as when the 12 ounce weight was employed. But by comparing the results in column 2d with the corresponding results in column 3d, it appears, that when the 24 ounce weight was employed, and the velocity was only one-half of what it was when the 12 ounce weight was used, the effect was *more than one-half*, the numbers in the 3d column being more than one-half the numbers in the 2d. Hence we may conclude, that the slower an overshot-wheel moves, the greater will be its performance.

262. These experiments of Deparcieux presented such unexpected results, as to induce other philosophers to examine them with care. The chevalier d'Arcy, in particular, considered them attentively. He maintained that there was a determinate velocity when the effect of the wheel reached its maximum; and he has shewn, by comparing the experiments of Deparcieux with his own formulae, that the overshot-wheel which Deparcieux employed never moved with such a small velocity as corresponded with the maximum effect, and that

On Water-Wheels. if he had increased the diameter of his cylinders, or the magnitude of the weights, his own experiments would have exhibited the degree of velocity, when the effect was the greatest possible.

His opinion confirmed by the experiments of Smeaton. 263. The reasoning of the chevalier d'Arcy is completely confirmed by the experiments of Smeaton. This celebrated engineer concludes with Deparcieux that, *cæteris paribus*, the less the velocity of the wheel, the greater will be its effect. But he observes, on the contrary, that when the wheel of his model made about 30 turns in a minute, the effect was nearly the greatest; when it made 30 turns, the effect was diminished about one-twentieth part; and that when it made 40 it was diminished about one-fourth; when it made less than 18½ turns, its motion was irregular, and when it was loaded so that it could not make 18 turns, the wheel was overpowered by its load. Mr Smeaton likewise observes, that when the circumferences of overshot wheels, whether high or low, move with the velocity of three feet per second, and when the other parts of the work are properly adapted to it, they will produce the greatest possible effect. He allows, however, that high wheels may deviate farther from this rule before losing their power than low ones can be permitted

to do; and assures us that he has seen a wheel 24 feet high moving at the rate of six feet per second, without losing any considerable part of its power, and likewise a wheel 33 feet high moving very steadily and well with a velocity but little exceeding two feet.

264. The experiments of the abbé Bossut may also be brought forward in support of the same reasoning. He employed a wheel 3 feet in diameter, furnished with 48 buckets, having each three inches of depth, and four inches of width. The canal which conveyed the water into the buckets was perfectly horizontal, and was five inches wide. It furnished uniformly 1194 cubic inches of water in a minute. The resistance to be overcome was a variety of weights fixed to the extremity of a cord, which, after passing over a pulley as in Deparcieux's experiments, winded round the cylindrical axle of the wheel. The diameter of this cylinder was two inches and seven lines, and that of the gudgeons or pivots of the wheel two lines and a half. The number of turns which the wheel made in a minute was not reckoned till its motion became uniform, which always happened when it had performed five or six revolutions. When the wheel was unloaded it made 40¼ turns in a minute.

Number of pounds raised.	Number of seconds in which the load was raised.	Number of revolutions performed by the wheel.	Effect of the wheel, or the product of the number of turns multiplied by the load.
11	60"	11½	131½
12	60	11¼	134¼
13	60	10¾	136¾
14	60	9¾	137¾
15	60	9½	138½
16	60	8½	138½
17	60	8¼	139¼
18	60	7½	138
19	The wheel turned but exceedingly slow.		
20	The wheel stopped though first put in motion by the hand to make it catch the water.		

265. It appears evidently from the last column, which we have computed on purpose, that the effect increases as the velocity diminishes; but that the effect is a maximum when the number of turns is 8½ in a minute, being then 139½. When the velocity was farther diminished by adding an additional pound to the resistance, the effect was diminished to 138, and when the velocity was still less, the wheel ceased to move.

Now since the wheel was three feet in diameter, and 9.42 feet in circumference, the velocity of its circumference will be about one foot four inches per second, when it performs 8½ turns in a minute, or when the maximum effect is produced. With Mr Smeaton's model, the maximum effect was produced when the velocity of the wheel's circumference was two feet per second. So that the experiments both of Smeaton and Bossut concur to prove, that the power of overshot

wheels increases as the velocity diminishes; but that there is a certain velocity, between one and two feet per second, when the wheel produces a maximum effect. Since when the wheel was unloaded it turned 40¼ times in a minute, and performed only 8½ revolutions when its power was a maximum, the velocity of the wheel when unloaded will be to its velocity when the effect is the greatest, as five to one, nearly.

266. The chevalier de Borda maintains that an overshot wheel will raise through the height of the fall a feet of quantity of water equal to that by which it is driven, and Albert Euler has shewn that the effect of these wheels is very much inferior to the momentum or force which impels them. It appears, however, from Mr Smeaton's experiments, that when the work performed was a maximum, the ratio of the power to the effect was as four to three, when the height of the fall

On Water. **Wheels.** fall and the quantities of water expended were the least; but that it was as four to two when the heights of the fall and the quantities discharged were the greatest. By taking a mean between these ratios, we may conclude, in general, that in overshot wheels the power is to the effect as three to one. In this case the power is supposed to be computed from the whole height of the fall; because the water must be raised to that height in order to be in a condition of producing the same effect a second time. When the power of the water is estimated only from the height of the wheel, the ratio of the power to the effect was more constant, being nearly as five to four.

Investigations of Albert Euler. 267. The theory of overshot wheels has been ably discussed by Albert Euler, and Lambert. The former of these philosophers has shown that the altitude of the

On Water. **Wheels.** wheel should be made as great as possible: that the buckets should be made as capacious as other circumstances will permit; that their form should be such as to convey the water as near the lowest point of the wheel as can be conveniently done; and that the motion of the wheel should be slow, that the buckets may be completely filled. He has likewise shown that the effect of the wheel increases as its velocity is diminished; and that overshot wheels should be used only when there is a sufficient height of fall. The results of Lambert's investigations are less consonant with the experiments of Smeaton. By examining the following table, which contains these results, it will appear at once that he makes the diameter of the wheel much smaller than it ought to be.

TABLE for Overshot Mills.

Height of the fall, reckoning from the surface of the stream.	Radius of the wheel, reckoning from the extremity of the buckets.	Width of the buckets.	Depth of the buckets.	Velocity of the wheel per second.	Time in which the wheel performs one revolution	Turns of the mill-stone for one of the wheel.	Force of the water upon the buckets.	The length of m, n , in Plate CCLXIX.	The length of n, o , in Fig. 6. Plate CCLXIX.	Quantity of water required per second to turn the wheel.
Feet.	Feet.	Feet.	Feet.	Feet.	Seconds.		lbs. Avoir	Feet.	Feet.	Cub. Feet.
7	2.83	1.00	2.02	5.27	3.38	8.45	636	0.33	1.15	10.55
8	3.22	1.14	1.44	5.63	3.61	9.02	595	0.38	1.32	9.23
9	3.63	1.27	1.07	5.94	3.83	9.57	565	0.42	1.48	8.21
10	4.04	0.43	0.82	6.30	4.04	10.10	531	0.48	1.65	7.38
11	4.45	0.57	0.65	6.60	4.23	10.57	511	0.52	1.81	6.71
12	4.86	0.71	0.52	6.89	4.42	11.05	486	0.57	1.98	6.15
1	2	3	4	5	6	7	8	9	10	11

SECT. II. On Breast Wheels.

Description of breast-wheels. Plate CCLXIX. fig. 6. 268. A breast wheel partakes of the nature both of an overshot and an undershot wheel, and is driven partly by the impulse, but chiefly by the weight of the water. A water wheel of this kind is represented in fig. 6. where MC is the stream of water falling on the floatboard o , with a velocity corresponding to the altitude mn , and afterwards acting by its weight on the floatboards between o and B. The mill course oB is made concentric with the wheel, which is fitted to it in such a manner that very little water is allowed to escape at the sides and extremities of the floatboards. According to Mr Smeaton, the effect of a wheel driven in this manner is equal to the effect of an undershot wheel whose head of water is equal to the difference of level between the surface of water in the reservoir, and

the point where it strikes the wheel, added to that of an overshot whose height is equal to the difference of level between the point where it strikes the wheel and the level of the tail water (n). That is, the effect of the wheel A is equal to that of an undershot wheel driven by a fall of water equal to mn , added to that of an overshot wheel whose height is equal to nD .

269. Mr Lambert of the academy of sciences at Berlin (n) has shown that when the floatboards arrive at the position op , they ought to be horizontal: the point p should be lower than o , in order that the whole space between any two adjacent floatboards may be filled with water; and that Cm should be equal to the depth of the floatboards. He observes also, that a breast wheel should be used when the fall of water is above four feet in height, and below ten. The following table is calculated from Lambert's formulae, and exhibits at one view the results of his investigations.

TABLE

(n) Smeaton on Mills, schol. p. 36.
 (n) *Nouv. Mem. de l'Academie de Berlin*, 1775, p. 71.

TABLE for Breast Mills.

Height of the fall in feet=CD, fig. 6. Plate CCLXIX.	Breadth of the float-boards.	Depth of the float-boards.	Radius of the water wheel reckoned from the extremity of the float-boards.	Velocity of the wheel per second.	Time in which the wheel performs one revolution	Turns of the mill-stone for one of the wheel.	Force of the water upon the float-boards	The length of <i>m, n</i> , in Fig. 6. Plate CCLXIX.	The length of <i>m, o</i> , in Fig. 6. Plate CCLXIX.	Water required per second to turn the wheel.
	Feet.	Feet.	Feet.	Feet.	Seconds.		lbs. Avoir.	Feet.	Feet.	Cub. Feet.
1	0.17	198.6	0.75	2.18	1.92	4.80	1536	0.08	0.23	74.30
2	0.34	35.1	1.50	3.09	2.72	6.80	1084	0.15	0.46	37.15
3	0.51	12.7	2.26	3.78	3.33	8.32	886	0.23	0.68	24.77
4	0.69	6.2	3.01	4.36	3.84	9.60	768	0.30	0.91	18.57
5	0.86	3.57	3.76	4.88	4.28	10.70	686	0.38	1.14	14.86
6	1.03	2.25	4.51	5.35	4.70	11.76	626	0.46	1.37	12.38
7	1.20	1.53	5.26	5.77	5.08	12.70	581	0.53	1.60	10.61
8	1.37	1.10	6.02	6.17	5.43	13.58	543	0.60	1.83	9.29
9	1.54	0.81	6.77	6.55	5.76	14.40	512	0.68	2.05	8.26
10	1.71	0.79	7.52	6.90	6.07	15.18	486	0.76	2.28	7.43
I	2	3	4	5	6	7	8	9	10	11

270. It appears from the preceding table, that when the altitude of the fall of water is below three feet, there is such an unsuitable proportion between the depth and width of the floatboards, that a breast wheel cannot well be employed. It is also evident, on the other hand, that when the height of the fall approaches to ten feet, the depth of the floatboards is too small in relation to their width. These two extremes, therefore, ought to be avoided in practice. The eleventh column of the table contains the quantity of water necessary to drive the wheel; but the total quantity of water should always exceed this, by the quantity, at least, that escapes between the mill course and the sides and extremities of the floatboards (o).

271. The following are the dimensions of an excellent breast water wheel, differing very little from that which is represented in fig. 6. The water, however, instead of falling through the height *cn* which is 16 inches, is delivered on the floatboard *op*, through an adjutage six inches and a half high.—The height *nD* is four feet two inches; and therefore the whole height *CD* must be five feet and a half. The radius of the wheel *AB* is six feet and a half, the breadth of each floatboard six inches and a half, and their depth 28 inches. The point *P* of the wheel moves with the velocity of 7.588 feet in a second. The quantity of water discharged in a second is 3.266 cubic feet, and the force of impulsion upon the floatboards 356 pounds avoirdupois. On some occasions buckets have been used in breast wheels instead of floatboards; but this is evidently a disadvantage, as the height through which the water acts is diminished by the number of inches through which the water must fall in order to acquire the velocity of the wheel, and also by the versed sine of the arch above the lowest point of the wheel which may be considered as not loaded with water.

SECT. III. On Undershot Wheels.

272. AN undershot wheel is a wheel with a number of floatboards disposed on its circumference, which receive the impulse of the water conveyed to the lowest point of the wheel by an inclined canal. It is represented in fig. 1. where *WW* is the water wheel, and *ABDFHKMV* the canal or mill course, which conveys the water to *K*, where it strikes the plane floatboards *no*, &c. and makes the wheel revolve about its axis. Description of an undershot wheel. Plate CCLXX. fig. 1.

273. In order to construct the mill course to the greatest advantage, we must give but a very small declivity to the canal which conducts the water from the river. It will be sufficient to make *AB* slope about one inch in 200 yards, making the declivity, however, about half an inch for the first 48 yards, in order that the water may have sufficient velocity to prevent it from falling back into the river. The inclination of the fall, represented by the angle *GCR*, should be $25^{\circ} 50'$, or *CR* the radius should be to *GR*, the tangent of this angle, as 100 to 28, or as 25 to 12; and since the surface of the water *Sb* is bent from *ab* into *ac* before it is precipitated down the fall, it will be necessary to incurvate the upper part *BCD* of the course into *BD*, that the water in the bottom may move parallel to the water at the surface of the stream. For this purpose take the points *B, D* about 12 inches distant from *C*, and raise the perpendiculars *BE, DE*. The point of intersection *E* will be the centre from which the arch *BD* is to be described; the radius being about $10\frac{1}{2}$ inches. Now, in order that the water may act more advantageously upon the floatboards of the wheel *WW*, it must assume a horizontal direction, with the same velocity which it would have acquired when it came to the point *G*. But, if the water were allowed to fall from *C* to *G*, it would dash upon the horizontal part *HG*, and thus

On Water- thus lose a great part of its velocity. It will be necessary, therefore, to make it move along FH, an arch of a circle to which DF and KH are tangents in the points F and H. For this purpose make GF and GH each equal to three feet; and raise the perpendiculars HI, FI which will intersect one another in the point I, distant about four feet nine inches from the points F and H, and the centre of the arch FH will be determined. The distance HK, through which the water runs before it acts upon the wheel, should not be less than two or three feet, in order that the different filaments of the fluid may have attained a horizontal direction. If HK were too large, the steam would suffer a diminution of velocity by its friction on the bottom of the course. That no water may escape between the bottom of the course KH and the extremities of the floatboards, KL should be about three inches, and the extremity *o* of the floatboard *no* ought to reach below the line HKX, sufficient room being left between *o* and M for the play of the wheel; or KLM may be formed into the arch of a circle KM concentric with the wheel. The line LMV, which has been called the course of impulsion, should be prolonged so as to support the water as long as it can act upon the floatboards, and should be about nine inches distant from OP, a horizontal line passing through O the lowest point of the fall; for if OL were much less than nine inches, the water having spent the greatest part of its force in impelling the floatboard, would accumulate below the wheel, and retard its motion. For the same reason another course, which has been called the course of discharge, should be connected with LMV by the curve VN to preserve the remaining velocity of the water, which would otherwise be discharged by falling perpendicularly from V to N. The course of discharge, which is represented by the line VZ, sloping from the point O, should be about 16 yards long, having an inch of declivity for every two yards. The canal which reconducts the water from the course of discharge to the river should slope about four inches in the first 200 yards, three inches in the second 200 yards, decreasing gradually till it terminates in the river. But if the river to which the water is conveyed should, when swelled by the rains, force the water back upon the wheel, the canal must have a greater declivity to prevent this from taking place. Hence it is evident that very accurate levelling is requisite to the proper formation of the mill course.

Plate
CCLXX.
fig. 2.

As it is of great importance that none of the water should escape either below the floatboards, or at their sides, without contributing to turn the wheel, the course of impulsion KV should be wider than the course at K, as represented in fig. 2. where CD the course of impulsion corresponds with LV in fig. 1. AB corresponds with HK and BC with KL. The breadth of the floatboards therefore should be wider than *mn*, and their extremities should reach a little below B, like *no* in fig. 1. When these precautions are properly taken, no water can escape without exerting its force upon the floatboards.

273. It has been disputed among philosophers, whether the wheel should be furnished with a small or a great number of floatboards. M. Pitot has shewn, that when the floatboards have different degrees of obliquity, the force of impulsion upon the different surfaces will be reciprocally as their breadths: Thus in fig. 3. the force of impulsion upon *he* will be to the force upon DO, as DO to *he* (P). Hence he concludes that the distance between the floatboards should be equal to one-half of the immersed arch, or that when one floatboard is at the bottom of the wheel, and perpendicular to the current, as DE, the preceding floatboard BC should be just leaving the stream, and the succeeding one FG just immersing into it. For when the three floatboards FG, DE, BC have the same position as in the figure, the whole force of the current NM will act upon DE when it is in the most advantageous position for receiving it, whereas, if another floatboard *de* were inserted between FG and DE, the part *ig* would cover DO, and by thus substituting an oblique for a perpendicular surface, the effect would be diminished in the proportion of DO to *ig*. Hence it is evident that, upon this principle, the depth of the floatboard DE should be always equal to the versed sine of the arch EG (Q).

On Wat
Wheel
On the
number
floatboar
in under
shot whe
FIG. 3.
Role give
by Pitot.

274. Notwithstanding the plausibility of this reasoning, it will not be difficult to shew that it is destitute of foundation. It is evident from fig. 3. that when one of the floatboards DE is perpendicular to the stream, it receives the whole impulse of the water in the most advantageous manner. But when it arrives at the position *de*, and the succeeding one FG at the position *fg*, so that the angle *eAg* may be bisected by the perpendicular AE; the situation of these floatboards will be the most disadvantageous, for a great part of the water will escape between the extremities *g* and *e* of the floatboards without striking them, and the part *ig* of the floatboard, which is really impelled, is less than DE, and oblique to the current. The wheel, therefore, must move irregularly, sometimes quick and sometimes slow, according to the position of the floatboards with respect to the stream: and this inequality will increase with the arch plunged in the water. The reasoning of M. Pitot, indeed, is founded on the supposition, that if another floatboard *fg* were placed between FG and DE it would annihilate the force of the water that impels it, and prevent any of the fluid from striking the corresponding part DO of the preceding floatboard. But this is not the case. For when the water has acted upon *fg*, it still retains a part of its motion, and after bending round the extremity *g* strikes DE with its remaining force. We are entitled, therefore, to conclude that advantage must be gained by using more floatboards than are recommended by Pitot.

proved to
be inaccur
rate.
FIG. 3.

275. It is evident from the preceding remarks, that in order to remove any inequality of motion in the wheel, and prevent the water from escaping below the extremities of the floatboards, the wheel should be furnished with the greatest possible number of floatboards, without loading it too much, or enfeebling the rim on which they are

The number of the floatboards should be as great as possible.

(P) *Mem. de l'Acad. Paris*, 1729, 8vo. p. 359.

(Q) A table containing the number of floatboards for wheels of different diameters, and founded on this principle, has been computed by Mr Brewster. See *Appendix to Ferguson's Lectures*, vol. ii. p. 149. 2d Edit.

Water-Wheels. are fixed. This rule was first given by M. Dupetit Vaudin (R); and it is easily perceived, that if the mill-wright should err in using too many floatboards, this error in excess will be perfectly trifling, and that a much greater loss of power would be occasioned by an error in defect.

276. The section of the floatboards ought not to be rectangular like *abc* in fig. 3. but should be bevelled like *abmc*. For if they were rectangular, the extremity *bn* would interrupt a portion of the water which would otherwise fall on the corresponding part of the preceding floatboard. In order to find the angle *abm*, subtract from 180 degrees the number of degrees contained in the immersed arch *CEG*, and the half of the remainder will be the angle required.

277. It has been maintained by M. Pitot and other philosophers, that the floatboards should be a continuation of the radius, or perpendicular to the rim, as in fig. 1. This indeed is true in theory, but it appears from the most unquestionable experiments, that they should be inclined to the radius. This important fact was discovered by Deparcieux in 1753, and proved by several experiments. When the floatboards are inclined, the water heaps up on their surface, and acts not only by its impulse but also by its weight. The same truth has also been confirmed by the abbé Bossut, the most accurate of whose experiments are contained in the following table. The wheel that was employed was immersed four inches vertically in the water, and it was furnished with 12 floatboards.

Inclination of the floatboard.	Number of pounds raised.	Time in which the load was raised in seconds.	Number of turns made by the wheel.
0	40	40	13 $\frac{7}{8}$
15	40	40	14 $\frac{2}{8}$
30	40	40	14 $\frac{3}{8}$
37	40	40	14 $\frac{5}{8}$
1	2	3	4

278. It is obvious, from the preceding table, that the wheel made the greatest number of turns, or moved with the greatest velocity, when the number of floatboards was between 15 and 30. When the water-wheels are placed on canals that have little declivity, and in which the water can escape freely after its impulse upon the floatboards, it would be proper to make the floatboards a continuation of the radius. But when they move in an inclined mill-course, an augmentation of velocity may be expected from an inclination of the floatboards.

279. Having thus pointed out the most scientific method of constructing the wheel, and delivering the water upon its floatboards, we have now to determine the velocity with which it should move. It is evident, that the velocity of the wheel must be always less than that

of the water which impels it, even when there is no work to be performed; for a part of the impelling power is necessarily spent in overcoming the inertia of the wheel and the resistance of friction. It is likewise obvious, that when the wheel has little or no velocity, its performance will be very trifling. There is, consequently, a certain proportion between the velocity of the water and the wheel, when its effect is a maximum. By the reasoning which is employed in the section on undershot wheels in the article *WATER-Works*, Parent and Pitot found, that a maximum effect was produced when the velocity of the wheel was one-third of the velocity of the water; and Desaguliers (s) Maclaurin (r), Lambert (u), and Atwood (x), have adopted their conclusions. In the calculus from which this result was deduced, it was taken for granted, that the momentum or force of water upon the wheel is in the duplicate ratio of the relative velocity, or as the square of the difference between the velocity of the water and that of the wheel. This supposition, indeed, is perfectly correct when the water impels a single floatboard; for as the number of particles which strike the floatboard in a given time, and also the momentum of these, are each as the relative velocity of the floatboards, the momentum must be as the square of the relative velocity, that is, $M \propto R^2$, *M* being the momentum, and *R* the relative velocity. But we have seen, in some of the preceding paragraphs, that the water acts on more than one floatboard at a time. Now the number of floatboards acted upon in a given time will be as the velocity of the wheel, or inversely as the relative velocity; for if you increase the relative velocity, the velocity of the water remaining the same, you must diminish the velocity of the wheel. Consequently, we shall have $M \propto \frac{R^2}{R}$ or $M \propto R$; that is, the momentum of the water acting upon the wheel, is directly as the relative velocity.

280. Let *V* be now the velocity of the stream, and *F* the force with which it would strike the floatboard at rest, and *v* the velocity of the wheel. Then the relative velocity will be *V-v*; and since the velocity of the water will be to its momentum, or the force with which it would strike the floatboard at rest, as the relative velocity is to the real force which the water exerts against the moving floatboards, we shall have

$V : V-v = F : F \times \frac{V-v}{V} = \frac{F}{V} \times V-v$. But the effect of the wheel is measured by the product of the momentum of the water and the velocity of the wheel, consequently the effect of the undershot wheel will be

$v \times \frac{F}{V} \times V-v = \frac{F}{V} \times Vv-v^2$. Now this effect is to be a maximum, and therefore its fluxion must be equal to 0, that is, *v*, being the variable quantity, $Vv - 2vv = 0$, or $2vv = Vv$. Dividing by *v*, we have $2v = V$.

(R) *Memoires des Savans Etrangers*, tom. i.
 (s) Desaguliers' *Experimental Philosophy*, vol. ii. p. 424. lect. 12.
 (r) Atwood on Rectilineal and Rotatory Motion, p. 275—284.
 (u) Maclaurin's *Fluxions*, art. 907. p. 728.
 (x) *Nouv. Memoires de l'Acad. Berlin*, 1775, p. 63.

On Water-Wheels. V , and $v = \frac{V}{2}$, that is, the velocity of the wheel will be *one half* the velocity of the fluid when the effect is a maximum.

281. This result, which was first obtained by the chevalier de Borda, has been amply confirmed by the experiments of Mr Smeaton. "The velocity of the stream (says he) varies at the maximum between one-third and one-half that of the water; but in all the cases in which most work is performed in proportion to the water expended, and which approach the nearest to the circumstances of great works, when properly executed, the maximum lies much nearer *one-half* than *one-third*, one half seeming to be the true maximum, if nothing were lost by the resistance of the air, the scattering of the water carried up by the wheel, &c."

282. A result, nearly similar to this, was deduced from the experiments of Bossut. He employed a wheel whose diameter was three feet. The number of floatboards was at one time 48, and at another 24, their width being five inches, and their depth six. The experiments with the wheel, when it had 48 floatboards, were made in an inclined canal, supplied from a reservoir by an orifice two inches deep, the velocity being 300 feet in 27 seconds. The experiments with the wheel, when it had 24 floatboards, were made in a canal, contained between two vertical walls, 12 or 13 feet distant. The depth of the water was about seven or eight inches, and its mean velocity about 2740 inches in 40 seconds. The floatboards of the wheel were immersed about four inches in the stream.

ter of the wheel, and the number of turns which it makes in 40 seconds, with the velocity of the current, it will be found, that the velocity of the wheel, when its effect is the greatest possible, is nearly *two-fifths* that of the stream. From the two last columns of the table, where the effect is a maximum when the load is 60 pounds, the same conclusion may be deduced.

284. The proper velocity of the wheel being thus established, we shall proceed to point out the method of constructing a mill-wright's table for undershot wheels, taking it for granted, that the velocity of the wheel should be one-half the velocity of the stream, and that water moves with the same velocity as falling bodies.

1. Find the perpendicular height of the fall of water above the bottom of the mill-course, and having diminished this number by one-half the depth of the water at K, call that the height of the fall.

2. Since bodies acquire a velocity of 32.174 feet, by falling through the height of 16.087 feet; and as the velocities of falling bodies are as the square roots of the heights through which they fall, the square root of 16.087 will be to the square root of the height of the fall as 32.174 to a fourth number, which will be the velocity of the water. Therefore the velocity of the water may be always found by multiplying 32.174 by the square root of the height of the fall, and dividing that product by the square root of 16.087. Or it may be found more easily by multiplying the height of the fall by the constant quantity $64.348 = 2 \times 32.174$, and extracting the square root of the product. This root, abstracting from the effects of friction, will be the velocity of the water required.

3. Take *one-half* the velocity of the water, and it will be the velocity which must be given to the floatboards, or the number of feet they must move through in a second, in order to produce a maximum effect.

4. Divide the circumference of the wheel by the velocity of its floatboards per second, and the quotient will be the number of seconds in which the wheel revolves.

5. Divide 60 by the number last found, and the quotient will be the number of turns made by the wheel in a minute.—Or the number of revolutions performed by the wheel in a minute may be found, by multiplying the velocity of the floatboards by 60, and dividing the product by the circumference of the wheel.

6. Divide 90, the number of revolutions which a millstone, five feet diameter, should make in a minute, by the number of revolutions made by the wheel in a minute; and the quotient will be the number of turns which the millstone ought to make for one revolution of the wheel.

7. Then as the number of revolutions of the wheel in a minute, is to the number of revolutions of the millstone in a minute, so must the number of staves in the trundle be to the number of teeth in the wheel, in the nearest whole numbers that can be found.

8. Multiply the number of revolutions performed by the wheel in a minute, by the number of revolutions made by the millstone for one of the wheel, and the product will be the number of revolutions made by the millstone in a minute.

285. By these rules, the following table has been computed

Time in which the load is raised.	No. of pounds raised.	Number of turns made by the wheel.	No. of pounds raised.	Number of turns made by the wheel.
Seconds	48 Floatboards.		48 Floatboards.	
40	30½	22½	30	17½
40	31	22½	35	16½
40	31½	21½	40	15½
40	32	21½	45	14½
40	32½	21½	50	13½
40	33	21½	55	12½
40	33½	20½	56	12½
40	34	20½	57	12½
40	34½	20½	58	12½
40	35	19½	59	12½
40	35½	19½	60	11½
40	36	18½	61	11½
40			62	11½
			63	11½
			64	10½
			65	10½
			66	10½

283. As the effect of the machine is measured by the product of the load raised, and the time employed, it will appear, by multiplying the second and third columns, that the effect was a maximum when the load was 34½ pounds, the wheel performing 20½ revolutions in 40 seconds. By comparing the velocity of the centre of impression computed from the diame-

Confirmed by Smeaton's experiments.

and by the experiments of Bossut.

Method constant wright's table.

ft. 6.

On Water-wheels. computed for a water wheel fifteen feet in diameter, which is a good medium size, the millstone being seven feet in diameter, and revolving 90 times in a minute.

de Borda supposes it never to exceed three-eighths; and Mr Smeaton and the abbé Bossut found two-fifths to be the proper medium (γ). With three-sevenths, therefore, as the best medium, which differs only $\frac{1}{15}$ th from $\frac{2}{5}$ ths, the numbers in the following table have been computed. In Table I. the water was supposed to move with the same velocity as falling bodies, but owing to its friction on the mill-course, &c. this is not exactly the case. We have therefore deduced the velocity of the water in column second,

TABLE I. A New Mill-Wright's Table, in which the Velocity of the Wheel is one-half the Velocity of the Stream, the effects of Friction not being considered.

from the following formula, $V = \sqrt{\frac{172}{3} \times R b \frac{H h}{2}}$, Fig. 1. in which V is the velocity of the water, R b the absolute height of the fall, and H h the depth of the water at the bottom of the course. The formula is founded on the experiments of Bossut, from which it appears, that if a canal be inclined one-tenth part of its length, this additional declivity will restore that velocity to the water which was destroyed by friction.

Height of the fall of water.	Velocity of the water per second, friction not being considered.	Velocity of the wheel per second, being one-half that of the water.	Revolutions of the wheel per minute, its diameter being 15 feet.	Revolutions of the mill-stone for one of the wheel.	Teeth in the wheel and staves in the trundle.	Revolutions of the mill-stone per minute by these staves and teeth.
Feet.	Feet. 100 parts of a foot.	Feet. 100 parts of a foot.	Revol. 100 parts of a revol.	Revol. 100 parts of a revol.	Teeth. Staves.	Revol. 100 parts of a revol.
1	8.02	4.01	5.10	17.65	106. 6	90.01
2	11.34	5.67	7.22	12.47	87. 7	90.03
3	13.89	6.95	8.85	10.17	81. 8	90.00
4	16.04	8.02	10.20	8.82	79. 9	89.96
5	17.94	8.97	11.43	7.87	71. 9	89.95
6	19.65	9.82	12.50	7.20	65. 9	90.00
7	21.22	10.61	13.51	6.66	60. 9	89.98
8	22.69	11.34	14.45	6.23	56. 9	90.02
9	24.06	12.03	15.31	5.88	53. 9	90.02
10	25.37	12.69	16.17	5.57	50. 10	90.06
11	26.60	13.30	16.95	5.31	53. 10	90.00
12	27.79	13.90	17.70	5.08	51. 10	89.91
13	28.92	14.46	18.41	4.89	49. 10	90.02
14	30.01	15.01	19.11	4.71	47. 10	90.00
15	31.07	15.53	19.80	4.55	48. 11	90.09
16	32.09	16.04	20.40	4.45	44. 10	89.96
17	33.07	16.54	21.05	4.28	47. 11	90.09
18	34.03	17.02	21.66	4.16	50. 12	90.10
19	34.97	17.48	22.26	4.04	44. 11	89.93
20	35.97	17.99	22.86	3.94	48. 12	90.07
1	2	3	4	5	6	7

TABLE II. A New Mill-Wright's Table, in which the Velocity of the Wheel is three-sevenths of the Velocity of the Water, and the effects of Friction on the Velocity of the stream reduced to computation.

Height of the fall of water.	Velocity of the water per second, friction being considered.	Velocity of the wheel per second, being 3-7ths that of the water.	Revolutions of the wheel per minute, its diameter being 15 feet.	Revolutions of the mill-stone for one of the wheel.	Teeth in the wheel and staves in the trundle.	Revolutions of the mill-stone per minute, by these staves and teeth.
Feet.	Feet. 100 parts of a foot.	Feet. 100 parts of a foot.	Revol. 100 parts of a revol.	Revol. 100 parts of a revol.	Teeth. Staves.	Revol. 100 parts of a revol.
1	7.62	3.27	4.16	21.63	130. 6	89.98
2	10.77	4.62	5.88	15.31	92. 6	90.02
3	13.20	5.66	7.20	12.50	100. 8	90.00
4	15.24	5.53	8.32	10.81	97. 9	89.94
5	17.04	7.30	9.28	9.70	97. 10	90.02
6	18.67	8.00	10.19	8.83	97. 11	89.98
7	20.15	8.64	10.99	8.19	90. 11	90.01
8	21.56	9.24	11.76	7.65	84. 11	89.96
9	22.86	9.80	12.47	7.22	72. 10	90.03
10	24.10	10.33	12.15	6.84	82. 12	89.95
11	25.27	10.83	13.79	6.53	85. 13	90.05
12	26.40	11.31	14.40	6.25	72. 12	90.00
13	27.47	11.77	14.99	6.00	72. 12	89.94
14	28.51	12.22	15.56	5.78	75. 13	90.04
15	29.52	12.65	16.13	5.58	67. 12	90.01
16	30.48	13.06	16.63	5.41	65. 12	89.97
17	31.42	13.46	17.14	5.25	63. 12	89.99
18	32.33	13.86	16.65	5.10	61. 12	90.01
19	33.22	14.24	18.13	4.96	64. 13	89.92
20	34.17	14.64	18.64	4.83	58. 12	89.84
1	2	3	4	5	6	7

286. The preceding table, computed by Mr Brewster (Appendix to Ferguson's Lectures, vol. ii. p. 174.) supposes, according to theory, that the velocity of the wheel, at the maximum effect, is one-half that of the stream, which is nearly the case in practice, when the quantities of water discharged by the stream are considerable. "When we consider, however, (observes the editor of the work now quoted), that after every precaution has been observed, a small quantity of water will escape between the mill course and the extremities of the floatboards, and that the effect is diminished by the resistance of the air and the dispersion of water carried up by the wheel, the propriety of making the wheel move with three-sevenths the velocity of the water will appear. The chevalier

(γ) The great hydraulic machine at Marly was found to produce a maximum effect, when its velocity was two-fifths that of the stream.

On Water-
Wheels.
Method of
using the
table.

287. In order that the wheel may move with a velocity duly adjusted to that of the current, we would not advise the mechanic to trust to the second column of Table II. for the true velocity of the stream, or to any theoretical results, even when deduced from formulæ founded on experiments. Bossut, with great justice, remarks, that "it would not be exact in practice to compute the velocity of a current from its declivity. This velocity ought to be determined by immediate experiment in every particular case." Let the velocity of the water, therefore, where it strikes the wheel, be determined by the method in the following paragraph. With this velocity, as an argument, enter column second of either of these tables, according as the velocity of the wheel is to be one-half or three-sevenths that of the stream, and take out the other numbers from the table.

Different
methods of
measuring
the veloci-
ty of the
stream.

288. Various methods have been proposed by different philosophers for measuring the velocity of running water; the method, by floating bodies, which Mariotte (Z) employed, the bent tube of Pitot (A), the regulator of Guglielmini (B), the quadrant (C), the little wheel (D), and the method proposed by the Abbé Mann (E), have each their advantages and disadvantages. The little wheel was employed in the experiments of Bossut. It is the most convenient mode of determining the superficial velocity of the water; and, when constructed in the following manner, will be more accurate, it is hoped, than any instrument that has hitherto been used. The small wheel WW should be formed of the lightest materials. It should be about 10 or 12 inches in diameter, and furnished with 14 or 16 floatboards. This wheel moves upon a delicate screw *a* B, passing through its axle B*b*; and when impelled by the stream it will gradually approach towards D, each revolution of the wheel corresponding with a thread of the screw. The number of revolutions performed in a given time are determined upon the scale *m* *a*, by means of the index O *h* fixed at O, and moveable with the wheel, each division of the scale being equal to the breadth of a thread of the screw, and the extremity *h* of the index O *h* coinciding with the beginning of the scale, when the shoulder *b* of the wheel is screwed close to *a*. The parts of a revolution are indicated by the bent index *m* *n* pointing to the periphery of the wheel, which is divided into 100 parts. When this instrument is to be used, take it by the handles C, D, or when great accuracy is required, make it rest on the handles C, D; and screw the shoulder *n* of the wheel close to *a*, so that the indices may both point to *o* the commencement of the scales. Then, by means of a stop-watch or pendulum, find how many revolutions of the wheel are performed in a given time. Multiply the mean circumference of the wheel (or the circumference deduced from the mean

radius, which is equal to the distance of the centre of the wheel from the axis *b* B) by the number of revolutions, and the product will be the number of feet through which the water moves in the given time. On account of the friction of the screw, the resistance of the air, and the weight of the wheel, its centre of impression will revolve with a little less velocity than that of the stream; but the diminution of velocity, arising from these causes, may be estimated with sufficient precision for all the purposes of the practical mechanic. (*Appendix to Ferguson's Lectures*, vol. ii. p. 177.)

289. It appears, from a comparison of the numerous and accurate experiments of Mr Smeaton, that, in undershot wheels, the power employed to turn the wheel is to the effect produced as 3 to 1; and that the load which the wheel will carry at its maximum, is to the load which will totally stop it, as 3 to 4. The same experiments inform us, that the impulse of the water on the wheel, in the case of a maximum, is more than double of what is assigned by theory, that is, instead of four-sevenths of the column, it is nearly equal to the whole column. In order to account for this, Mr Smeaton observes, that the wheel was not, in this case, placed in an open river, where the natural current, after it had communicated its impulse to the float, has room on all sides to escape, as the theory supposes; but in a conduit or race, to which the float being adapted, the water could not otherwise escape than by moving along with the wheel. He likewise remarks, that when a wheel works in this manner, the water, as soon as it meets the float, receives a sudden check, and rises up against it like a wave against a fixed object; insomuch, that when the sheet of water is not a quarter of an inch thick before it meets the float, yet this sheet will act upon the whole surface of a float, whose height is three inches. Were the float, therefore, no higher than the thickness of the sheet of water, as the theory supposes, a great part of the force would be lost by the water dashing over it. In order to try what would be the effect of diminishing the number of floatboards, Mr Smeaton reduced the floatboards, which were originally 24, to 12. This change produced a diminution of the effect, as a greater quantity of water escaped between the floats and the floor. But when a circular sweep was adapted to the floor, and made of such a length that one float entered the curve before the preceding one quitted it, the effect came so near to the former, as to afford no hopes of increasing it by augmenting the number of floats beyond 24 in this particular wheel. Mr Smeaton likewise deduced, from his experiments, the following maxims.

1. That the virtual or effective head being the same, the effect will be nearly as the quantity of water expended.

2. That

- (Z) *Traité du Mouvement des Eaux.*
 (A) *Mem. de l'Acad. Paris*, 1732.
 (B) *Aquarum Fluentium Mensura*, lib. iv.
 (C) Bossut *Traité d'Hydrodynamique*, art. 654.
 (D) *Id. id.* art. 655.
 (E) *Philosophical Transactions*, vol. lxix.

On Water-Wheels. 2. That the expence of water being the same, the effect will be nearly as the height of the virtual or effective head.

3. That the quantity of water expended being the same, the effect is nearly as the square of the velocity.

4. The aperture being the same, the effect will be nearly as the cube of the velocity of the water.

Undershot wheels with floatboards inclined to the plane of the wheel.
Plate CULXX.
fig. 5.

290. We have hitherto supposed the floatboards, though inclined to the radius, to be perpendicular to the plane of the wheel. Undershot-wheels, however, have sometimes been constructed with floatboards inclined to the plane of the wheel. A wheel of this kind is represented in fig. 5. where AB is the wheel, and CDEFGH the oblique floatboards. The horizontal current MN is delivered on the floatboards, so as to strike them perpendicularly. On account of the size of the floatboards, every filament of the water contributes to turn the wheel; and therefore its effect will be greater than in undershot wheels of the common form. Albert Euler imagines that the effect will be twice as great, and observes, that in order to produce such an effect, the velocity of the centre of impression should be to the velocity of the water, as radius is to triple the sine of the angle by which the floatboards are inclined to the plane of the wheel. If this inclination, therefore, be 60° , the velocity of the wheel at the centre of impression ought to be to the velocity of the impelling fluid as 1 to $\frac{3\sqrt{3}}{2}$, that is, as 5 to 13 nearly, because $\text{Sin. } 60^\circ = \frac{\sqrt{3}}{2}$. When the inclination is 30° , the ratio of the velocities will be found to be as 2 to 3.

and also to the radius.

291. In wheels of this kind, the floats may also be advantageously inclined to the radius. In this case, the stream, which still strikes them perpendicularly, is inclined to the horizon. If the angle formed by the common section of the wheel and floatboards with the radius of the wheel, be $= m$; and if the angle by which the floatboards are inclined to the plane of the wheel be $= n$, then the angle which the floatboards should form with the direction in which the wheel moves, will be $= \text{Cos. } m \times \text{Sin. } n$. In order, therefore, that the stream may strike the floatboards with a perpendicular impulse, its inclination to the horizon must be $= m$, and its inclination to the plane of the wheel $= 90^\circ - n$. The less that the velocity of the water is, the greater should be the angle m ; for there is, in this case, no danger that the celerity of the wheel be too great. The area of the floatboards ought to be much greater than the section of the current; and the interval between two adjacent floatboards should be so great, that before the one completely withdraws itself from the action of the water, the other should begin to receive its impulse.

On horizontal water-wheels.
Fig. 6.

292. Horizontal water-wheels have been much used on the continent, and are strongly recommended to our notice by the simplicity of their construction. In fig. 6. AB is the large water-wheel which moves horizontally upon its arbor CD. This arbor passes through the immoveable millstone EF at D, and being fixed to the upper one GH, carries it once round for every revolution of the great wheel. The mill-course is constructed in the same manner for horizontal as for verti-

cal wheels, with this difference only, that the part $mBnC$, fig. 2. of which KL in fig. 1. is a section, instead of being rectilineal like mn , must be circular like mP , and concentric with the rim of the wheel, sufficient room being left between it and the tips of the floatboards for the play of the wheel. In this construction, where the water moves in a horizontal direction before it strikes the wheel, the floatboards should be inclined about 25° to the plane of the wheel, and the same number of degrees to the radius, so that the lowest and outermost sides of the floatboards may be farthest up the stream.

293. Instead of making the canal horizontal before it delivers the water on the floatboards, they are frequently inclined in such a manner as to receive the impulse perpendicularly, and in the direction of the declivity of the mill-course. When this construction is adopted, the maximum effect will be produced when the

velocity of the floatboards is not less than $\frac{5.67\sqrt{H}}{2 \text{ Sin. } A}$, where H represents the height of the fall, and A the angle which the direction of the fall makes with a vertical line. But as the quantity $\frac{5.67\sqrt{H}}{2 \text{ Sin. } A}$ evidently

increases as the sine of A decreases, it follows, that without lessening the effect of these wheels, we may diminish the angle A, and thus augment considerably the velocity of the floatboards, according to the nature of the machinery employed; whereas, in vertical wheels, there is only one determinate velocity which produces a maximum effect.

294. In the southern provinces of France, where horizontal wheels are generally employed, the floatboards are made of a curvilinear form, so as to be concave towards the stream. The Chevalier de Borda observes, that in theory a double effect is produced when the floatboards are concave; but that the effect is diminished in practice, from the difficulty of making the fluid enter and leave the curve in a proper direction. Notwithstanding this difficulty, however, and other defects which might be pointed out, horizontal wheels with concave floatboards are always superior to those in which the floatboards are plane, and even to vertical wheels, when there is a sufficient fall of water. When the floatboards are plane, the wheel is driven merely by the impulse of the stream; but when they are concave, a part of the water acts by its weight and increases the velocity of the wheel. If the fall of water be 5 or 6 feet, a horizontal wheel with concave floatboards may be erected, whose maximum effect will be to that of the ordinary vertical wheels as 3 to 2.

295. An advantage attending horizontal wheels is, that the water may be divided into several canals, and delivered upon several floatboards at the same time. Each stream will heap up on its corresponding floatboard, and produce a greater effect than if the force of the water had been concentrated on a single floatboard. Horizontal wheels may be employed with greatest advantage when a small quantity of water falls through a considerable height.

296. It has been disputed among mechanical philosophers, whether overshot or undershot wheels produce the greatest effect. M. Belidor maintained that the former were inferior to the latter, while a contrary opinion

Overshot wheels superior to undershot ones.

Machines driven by the Reaction of Water.

was entertained by Desaguliers. It appears, however, from Mr Smeaton's experiments, that in overshot wheels the power is to the effect nearly as 3 to 2 or as 5 to 4 in general, whereas in undershot wheels, it is only as 3 to 1. The effect of overshot wheels therefore is nearly double that of undershot wheels, other circumstances being the same. In comparing the relative effects of water-wheels, the Chevalier de Borda remarks that overshot wheels will raise through the height of the fall, a quantity of water equal to that by which they are driven; that undershot vertical wheels will produce only three-eighths of this effect; that horizontal wheels will produce a little less than one half of it when the floatboards are plain, and a little more than one-half of it when the floatboards have a curvilinear form.

Besant's Undershot Wheel.

Description of Besant's water-wheel. Plate CCLXXI. Fig. 1. 297. The water-wheel invented by Mr Besant of Brompton is constructed in the form of a hollow drum, so as to resist the admission of the water. The floatboards are fixed obliquely in pairs on the periphery of the wheel, so that each pair may form an acute angle open at its vertex, while one of the floatboards extends beyond the vertex of the angle. A section of the water-wheel is represented in fig. 1. where AB is the wheel, CD its axis, *m n, op* the position of the floatboards. The motion of common undershot wheels is greatly retarded by the resistance which the tail-water and the atmosphere oppose to the ascending floatboards; but in Besant's wheel this resistance is greatly diminished, as the floats emerge from the stream in an oblique direction. Although this wheel is much heavier than those of the common construction, yet it revolves more easily upon its axis, as the stream has a tendency to make it float.

Conical Horizontal Wheel with Spiral Floatboards.

Description of a conical horizontal wheel with spiral floatboards. Fig. 2. 298. In Guyenne and Languedoc, in the south of France, a kind of conical horizontal wheel is sometimes employed for turning machinery. It is constructed in the form of an inverted cone AB, with spiral floatboards winding round its surface. The wheel moves on a vertical axis AB, in the building DD, and is driven chiefly by the impulse of the water conveyed by the canal B to the oblique floatboards, the direction of the current being perpendicular to the floatboards at the place of impact. When the impulsive force of the water is annihilated, it descends along the spirals, and continues to act by its weight till it reaches the bottom, when it is carried off by the canal M.

CHAP. II. On Machines driven by the Reaction of Water.

Water produces great effects by its reaction than by its impulse or weight. 299. WE have hitherto considered the mechanical effects of water as the impelling power of machinery, when it acts either by its impulse or by its gravity. The reaction of water may be employed to communicate motion to machinery; and though this principle has not yet been adopted in practice, it appears from theory, and from some detached experiments on a small scale,

that a given quantity of water, falling through a given height, will produce greater effects by its reaction than by its impulse or its weight.

SECT. I. On Dr Barker's Mill.

300. This machine, which is sometimes called Parent's mill, is represented in fig. 3. where A is the canal that conveys the water into the upright tube B, which communicates with the horizontal arm C. The water will therefore descend through the upright tube into this arm, and will exert upon the inside of it a pressure proportioned to the height of the fall. But if two orifices *d* and *e* be perforated at the extremities of the arm, and on contrary sides, the pressure upon these orifices will be removed by the efflux of the water, and the unbalanced pressure upon the opposite sides of the arm will make the tube and the horizontal arm revolve upon the spindle D as an axis. This will be more easily understood, if we suppose the orifices to be shut up, and consider the pressure upon a circular inch of the arm opposite to the orifice, the orifice being of the same size. The pressure upon this circular inch will be equal to a cylinder of water whose base is one inch in diameter, and whose altitude is the height of the fall; and the same force is exerted upon the shut-up orifice. These two pressures, therefore, being equal and opposite, the arm C will remain at rest. But as soon as you open the orifice, the water will issue with a velocity due to the height of the fall: the pressure upon the orifice will of consequence be removed; and as the pressure upon the circular inch opposite to the orifice still continues, the equilibrium will be destroyed, and the arm C will move in a retrograde direction.

301. The upright spindle D, on which the arm revolves, is fixed in the bottom of the arm, and screwed to it below by the nut *g*. It is fixed to the upright tube by two cross bars at *f*, so as to move along with it. If a corn mill is to be driven, the top of the spindle is fixed into the upper millstone H. The lower quiescent millstone I rests upon the floor K, in which is the hole L, to let the meal pass into a trough about M. The bridgetree GF, which supports the millstone, tube, &c. is moveable on a pin at *h*, and its other end is supported by an iron rod fixed into it, the top of the rod going through the fixed bracket *o*, furnished with a nut *o*. By screwing this nut, the millstone may be raised or lowered at pleasure. If any other kind of machinery is to be driven, the spindle D must be prolonged to X, and a small wheel W fixed to its extremity, which will communicate its motion to any species of mechanism. An improvement on this machine by M. Mathon de la Cour, and some excellent observations on the subject by Professor Robison, will be found in the article *WATER-Works*.

302. Mr Waring of the American Philosophical Society, has given a theory of Barker's mill with the improvement of M. Mathon de la Cour, which he has strangely ascribed to a Mr Rumsey about 20 years after it was published in *Rozier's Journal de Physique*, Jan. and August 1775. Contrary to every other philosopher, he makes the effect of the machine equal only to that of a good undershot-wheel, moved with the same quantity of water, falling through the same height. The following

Machines driven by the Reaction of Water.

Practical rules.

Machines driven by the Reaction of Water.

Plate CCLXXI. Fig. 5.

Fig. 6.

lowing rules, however, deduced from his calculus may be of use to those who may wish to make experiments on the effect of this interesting machine.

1. Make the arm of the rotatory tube or arm C, from the centre of motion to the centre of the aperture, of any convenient length, not less than one-third (one-ninth according to Mr Gregory (F), who has corrected some of Waring's numbers) of the perpendicular height of the water's surface above their centres.

2. Multiply the length of the arm in feet by .614, and take the square root of the product for the proper time of a revolution in seconds, and adapt the other parts of the machinery to this velocity; or, if the time of a revolution be given, multiply the square of this time by 1.63 for the proportional length of the arm.

3. Multiply together the breadth, depth, and velocity per second, of the race, and divide the last product by 18.47 times (14.27 according to Mr Gregory) the square root of the height, for the area of either aperture.

4. Multiply the area of either aperture by the height of the fall of water, and the product by $41\frac{2}{3}$ pounds (55.775 according to Mr Gregory), for the moving force estimated at the centres of the apertures in pounds avoirdupois.

5. The power and velocity at the aperture may be easily reduced to any part of the machinery by the simplest mechanical rules.

Form given to Barker's mill by Professor Segner.

Fig. 4.

303. Long after the preceding machine had been described in several of our English treatises on machines, Professor Segner published in his hydraulics, as an invention of his own, the account of a machine, differing from this only in form. MN was the axis of the machine, corresponding with DX in Barker's mill, and a number of tubes AB were also so arranged round this axis that their higher extremities A formed a circular superficies into which the water flowed from a reservoir. When the machine has this form, it has been shewn by Albert Euler that the maximum effect is produced when the velocity is infinite, and that the effect is equal to the power. As a considerable portion of the power, however, must be consumed in communicating to the fluid the circular motion of the tubes; and as the portion

thus lost must increase with the velocity of the tube, the effect will in reality sustain a diminution from an increase of velocity.

SECT. II. Description of Albert Euler's Machine driven by the Reaction of the Water.

304. THIS machine consists of two vessels, the lowest of which EEFF is moveable round the vertical axis OO, while the higher vessel remains immovable. The form of the lowest vessel, which is represented by itself in fig. 6. is similar to that of a truncated bell, which is fastened by the cross beams m, n to the axis O so as to move along with it. The annular cavity $h h h h$ terminates at ee in several tubes ef, ef, ef , diverging from the axis. Through the lower extremities of these tubes, which are bent into a right angle, the water flowing from the cavity $h h h h$ issues with a velocity due to the altitude of its surface in h, h , and produces by its reaction a rotatory and retrograde motion round the axis OO. The cavity of the ring h, h receives the water from the superior vessel GGHH, similar to the inferior vessel in fig. 6. but not connected with the axis OO. This vessel has also an annular cavity PP, into which the water is conveyed from a reservoir by the canal R. Around the lower part HH of the cavity, this vessel is divided into several apertures I i , placed obliquely that the water may descend with proper obliquity into the inferior vessel. The width of the higher vessel at HH ought to be equal to the width of the lower vessel at FF, that the water which issues from the former may exactly fill the annular cavity h, h, h, h .

When the machine is constructed in this way, its maximum effect will be equal to the power, provided all its parts be proportioned and adjusted according to the results in the following table, computed from the formulæ of Albert Euler. In the table,

- Q = the quantity of water, or number of cubic feet of water furnished in a second.
- T = the time, or number of seconds in which the lower vessel revolves.
- B = the breadth of the annular orifice in inches.

Machines driven by the Reaction of Water.

Table for mills driven by the reaction of water.

TABLE for Mills driven by the Reaction of Water.

Machines driven by the Reaction of Water.

Height of the fall of water.	Sum of the areas of all the orifices at <i>f, f, f, &c.</i>	Sum of the areas of all the orifices at <i>f, f, f, &c.</i>	Mean radius of the annular orifice HH.	Difference between the altitude of the two vessels.	Tangent of the inclination of the tubes to the horizon.
Feet.	Square Feet.	Square Inches.	Feet.	Inches.	
1	$0.17888 \times Q$	$2.5759 \times Q$	$0.8897 \times T$	$1.7695 \frac{QQ}{TTBB}$	$0.38400 \frac{Q}{TB}$
2	$0.12649 \times Q$	$18.214 \times Q$	$1.2582 \times T$	$0.8847 \frac{QQ}{TTBB}$	$0.19200 \frac{Q}{TB}$
3	$0.103228 \times Q$	$14.872 \times Q$	$1.5410 \times T$	$0.5898 \frac{QQ}{TTBB}$	$0.12800 \frac{Q}{TB}$
4	$0.08944 \times Q$	$12.880 \times Q$	$1.7794 \times T$	$0.4424 \frac{QQ}{TTBB}$	$0.09600 \frac{Q}{TB}$
5	$0.08000 \times Q$	$11.520 \times Q$	$1.9894 \times T$	$0.3539 \frac{QQ}{TTBB}$	$0.07680 \frac{Q}{TB}$
6	$0.07303 \times Q$	$10.516 \times Q$	$2.1793 \times T$	$0.2949 \frac{QQ}{TTBB}$	$0.06400 \frac{Q}{TB}$
7	$0.06761 \times Q$	$9.736 \times Q$	$2.3540 \times T$	$0.2528 \frac{QQ}{TTBB}$	$0.05486 \frac{Q}{TB}$
8	$0.06325 \times Q$	$9.107 \times Q$	$2.5165 \times T$	$0.2212 \frac{QQ}{TTBB}$	$0.04800 \frac{Q}{TB}$
9	$0.05963 \times Q$	$8.586 \times Q$	$2.6691 \times T$	$0.1966 \frac{QQ}{TTBB}$	$0.04267 \frac{Q}{TB}$
10	$0.05657 \times Q$	$8.146 \times Q$	$2.8135 \times T$	$0.1769 \frac{QQ}{TTBB}$	$0.03840 \frac{Q}{TB}$
11	$0.05394 \times Q$	$7.767 \times Q$	$2.9508 \times T$	$0.1609 \frac{QQ}{TTBB}$	$0.03494 \frac{Q}{TB}$
12	$0.05104 \times Q$	$7.436 \times Q$	$3.0820 \times T$	$0.1475 \frac{QQ}{TTBB}$	$0.03200 \frac{Q}{TB}$
13	$0.04961 \times Q$	$7.144 \times Q$	$3.2078 \times T$	$0.1361 \frac{QQ}{TTBB}$	$0.02954 \frac{Q}{TB}$
14	$0.04781 \times Q$	$6.885 \times Q$	$3.3290 \times T$	$0.1264 \frac{QQ}{TTBB}$	$0.02745 \frac{Q}{TB}$
15	$0.04619 \times Q$	$6.651 \times Q$	$3.4458 \times T$	$0.1179 \frac{QQ}{TTBB}$	$0.02560 \frac{Q}{TB}$
16	$0.04472 \times Q$	$6.440 \times Q$	$3.5588 \times T$	$0.1106 \frac{QQ}{TTBB}$	$0.02400 \frac{Q}{TB}$
17	$0.04339 \times Q$	$6.248 \times Q$	$3.6683 \times T$	$0.1041 \frac{QQ}{TTBB}$	$0.02259 \frac{Q}{TB}$
18	$0.04216 \times Q$	$6.072 \times Q$	$3.7747 \times T$	$0.0983 \frac{QQ}{TTBB}$	$0.02133 \frac{Q}{TB}$
1	2	3	4	5	6

Explanation of the table.

The determinations in the preceding table are exhibited in a general manner, that the machine may be accommodated to local circumstances. The time of a revolution T, for instance, is left undetermined, because upon this time depends the magnitude of the machine; and T may be assumed of such a value that the dimensions of the machine may be suitable to the given place, or to the nature of the work to be performed.

Example

305. In order to shew the application of the preceding table, let it be required to construct the machine when the height of the fall is five feet, and when the

reservoir furnishes one cubic foot of water in a second. In this case $Q=1$, and therefore, by column 3d, the sum of the areas of the orifices will be 11.52 square inches. Consequently, if there are twelve orifices, the area of each orifice will be $\frac{11.52}{12} = 0.96$ of a square inch. Suppose the time of a revolution to be $=1$ second or $T=1$, then the 4th column will give the mean radius of the annular orifice $=1.9894$ feet, or nearly two feet. Let the breadth of the annular orifice or $B=\frac{1}{2}$ an inch, then the difference between the altitude of

On Machines for raising Water.

of each vessel will be $0.3539 \times \frac{QQ}{TTBB} = 0.3539 \times \frac{I \times I}{\frac{1}{2} \times \frac{1}{2} \times I \times I} = 0.3539 \times \frac{I}{\frac{1}{2}} = 0.3539 \times 2 = 1.4156$ inches.

Now as the sum of the heights of the vessels must be always equal to the height of the fall, half that sum will in the present case be two feet six inches; and since half the difference of their altitudes is 7-tenths of an inch, the altitude of the superior vessel will be two feet six inches and seven-tenths, and that of the inferior vessel two feet five inches and three-tenths. It appears from the last column of the table, that the tangent of the inclination of the tubes is 0.1536, which corresponds with an angle of 8° 44'.

Reference to the researches of Leonhard Euler.

306. The theory of this machine has also been discussed by Leonhard Euler in the *Mém. de l'Acad. Berlin*, vol. vi. p. 311.; and its application to all kinds of work has been pointed out in a subsequent paper, entitled, *Application de la Machine Hydraulique de M. Segner à toutes sortes d'ouvrage, et de ses avantages sur les autres Machines Hydrauliques dont on se sert ordinairement*, *Mém. Acad. Berlin*, tom. vii. 1752, p. 271. The results of Euler's analysis are not sufficiently practical for the use of the general reader. But it appears from his investigations, as well as from those of John Bernouilli and other philosophers, that the reaction of water is the most powerful way in which the force of that fluid can be employed.

New kind of water-wheel suggested.

307. It has often occurred to the writer of this article, that a very powerful hydraulic machine might be constructed by combining the impulse with the reaction of water. If the spout *a*, for example, instead of delivering the water into the higher vessel, were to throw it upon a number of curvilinear floatboards fixed on its circumference, and so formed as to convey the water easily into the spiral canals, we should have a machine something like the conical horizontal wheel in fig. 2. with spiral channels instead of spiral floatboards; and which would in some measure be moved both by the impulse, weight, and reaction of the water.

Plate CCLXXXI

Fig. 2.

CHAP. III. On Machines for raising Water.

SECT. I. On Pumps.

Reference to the article PUMP.

308. THE subject of pumps has been fully and ably discussed by Dr Robison under the article PUMP, to which we must refer the reader for a complete view of the theory of the machine. In that article, however, a reference is made to the present for a description of the ancient pump of Ctesibius, and of those in common use to which it has given rise. To these subjects, therefore, we must now confine our attention.

Description of the original pump of Ctesibius.

309. The pump was invented by Ctesibius, a mathematician of Alexandria, who flourished under Ptolemy Ptochus, about 120 years before Christ. In its original state it is represented in fig. 1. where ABCD is a brass cylinder with a valve *L* in its bottom. It is furnished with a piston MK made of green wood, so as not to swell in water, and adjusted to the bore of the cylinder by the interposition of a ring of leather. The tube CI connects the cylinder ABCD with another tube NH, the bottom of which is furnished with a valve *I* opening upwards. Now when the extremity DC of the cylinder is immersed in water, and the pis-

Plate CCLXXXII

Fig. 1.

On Machines for raising Water.

ton MK elevated, the pressure of the water upon the valve *L* from below will be proportioned to the depth below the surface (41). The valve will therefore open and admit the water into the cylinder. But when the piston is depressed, it will force the water into the tube CH, and through the valve *I* into the tube NH. As soon as the portion of water that was admitted into the cylinder ABCD, is thus impelled into the tube NH, the valve *I* will close. A second elevation of the piston will admit another quantity of fluid into the cylinder, and a second depression will force it into the tube NH; so that, by continuing the motion of the piston, the water may be elevated to any altitude in the tube. From this pump of Ctesibius are derived the three kinds of pumps now commonly used, the sucking, the forcing, and the lifting pump.

310. The common sucking pump is represented in Description fig. 2. where ICBL is the body of the pump immersed in the water at A. The moveable piston DG is composed of the piston rod *Dd*, the piston or bucket *G*, and the valve *a*: The bucket *H*, which is fixed to the body of the pump, is likewise furnished with a valve *b*, which, like the valve *a*, should by its own weight lie close upon the hole in the bucket till the working of the engine commences. The valves are made of brass, and have their lower surface covered with leather, in order to fit the holes in the bucket more exactly. The moveable bucket *G* is covered with leather, so as to suit exactly the bore of the cylinder, and to prevent any air from escaping between it and the pump. The piston DG may be elevated or depressed by the lever *DQ*, whose fulcrum is *r*, the extremity of the bent arm *Rr*.

of the sucking pump. Fig. 2.

311. Let us now suppose the piston *G* to be depressed so that its inferior surface may rest upon the valve *b*. Then if the piston *G* be raised to *C*, there would have been a vacuum between *H* and *G* if the valve *b* were immovable. But as the valve *b* is moveable, and as the pressure of the air in the tube HL will, by its elasticity, force open the valve *b*, and expand itself through the whole cavity LC. This air, however, will be much rarer than that of the atmosphere; and since the equilibrium between the external air and that in the tube LH is destroyed by the rarefaction of the latter, the pressure of the atmosphere on the surface of the water in the vessel *K* will predominate, and raise the water to about *e* in the section pipe HL, so that the air formerly included in the space LC will be condensed to the same state as that of the atmosphere. The elasticity of the air both above and below the valve *b* being now equal, that valve will fall by its own weight.—Let the piston DG be now depressed to *b*. The air would evidently resist its descent, did not the valve *a* open and give a free exit to the air in the space CH, for it cannot escape through the inferior valve *b*. When the piston reaches *b*, the valve *a* will fall by its weight; and when the piston is again elevated, the incumbent air will press the valve *a* firmly upon its orifice. During the second ascent of the piston to *C* the valve *b* will rise, the air between *e* H will rush into HC; and in consequence of its rarefaction, and inability to counteract the pressure of the atmosphere, the water will rise to *f*. In the same way it may be shewn, that at the next stroke of the piston the water will rise through the box *H* to *B*,

On Machines for raising Water.

and then the valve *b* which was raised by it will fall when the bucket *G* is at *C*. Upon depressing the bucket *G* again, the water cannot be driven through the valve *b*, which is pressed to its orifice by the water above it. At the next ascent of the piston a new quantity of water will rise through *H*, and follow the piston to *C*. When the piston again descends, the valve *a* will open; and as the water between *C* and *H* cannot be pushed through the valve *b*, it will rise through *a*, and have its surface at *C* when the piston *G* is at *b*; but when the piston rises, the valve *a* being shut by the water above it, this water will be raised up towards *I*, and issue at the pipe *F*. A new quantity of water will rush through *H* and fill the space *HC*; consequently, the surface of the fluid will always remain at *C*, and every succeeding elevation of the piston from *b* to *C* will make the column of water *CH* run out at the pipe *F*.

The sucking pump will not raise water higher than 33 feet.

312. As the water rises in the pipe *CL* solely by the pressure of the atmosphere; and as a column of water, 33 feet high, is equal in weight to a column of air of the same base, reaching from the earth's surface to the top of the atmosphere, the water in the vessel *K* will not follow the piston *G* to a greater altitude than 33 feet; for when it reaches this height, the column of water completely balances, or is in equilibrium with, the atmosphere, and therefore cannot be raised higher by the pressure of the external air.

Description of the forcing pump.

Plate CCLXXII. Fig. 3.

Mode of its operation.

313. The forcing pump is represented in fig. 3. where *Dd* is the piston attached to a solid plunger *g*, adjusted to the bore of the pipe *BC* by the interposition of a ring of leather. The rectangular pipe *MMN* communicates with the tube *BC* by the cavity round *H*; and its upper extremity *P* is furnished with a valve *a* opening upwards. An air-vessel *KK* is fastened to *P*, and the tube *FGI* is introduced into it so as to reach as near as possible to the valve *a*.—Let us now suppose the plunger *Dg* to be depressed to *b*. As soon as it is elevated to *C* the air below it will be rarefied, and the water will ascend through the valve *b* in the same way as in the sucking pump, till the pipe is filled to *C*. The valve *b* will now be shut by the weight of the incumbent water; and therefore when the plunger *Dg* is depressed, it will force the water between *C* and *b* through the rectangular pipe *MMN*, into the air vessel *KK*. Before the water enters the air vessel, it opens the valve *a*, which shuts as soon as the plunger is again raised, because the pressure of the water upon its under side is removed. In this way the water is driven into the air vessel by repeated strokes of the plunger, till its surface is above the lower extremity of the pipe *IG*. Now, as the air in the vessel *KK* has no communication with the external air when the water is above *I*, it must be condensed more and more, as new quantities of water are injected. It will therefore endeavour to expand itself, and by pressing upon the surface *H* of the water in the air vessel, it will drive the water through the tube *IG*, and make it issue at *F* in a continued stream, even when the plunger is rising to *C*. If the pipe *GHI* were joined to the pipe *MMN* at *P*, without the intervention of an air vessel, the stream of water would issue at *F* only when the plunger was depressed.

314. The lifting pump, which is only a particular modification of the forcing pump, is represented in fig. 4. The barrel *AB* is fixed in the immoveable frame *KILM*, the lower part of which is immersed in the water to be raised. The frame *GEQHO* consists of two strong iron rods *EQ*, *GH* which move through holes in *IK* and *LM*, the upper and lower ends of the pump. To the bottom *GH* of this frame is fixed an inverted piston with its bucket and valve uppermost at *D*. An inclined branch *KH*, either fixed to the top of the barrel, or moveable by a ball and socket, as represented at *F*, must be fitted to the barrel so exactly as to resist the admission both of air and water. The branch *KH* is furnished with a valve *C* opening upwards. Let the pump be now plunged in the water to the depth of *D*. Then if the piston frame be thrust down into the fluid, the piston will descend, and the water by its upward pressure will open the valve at *D* and gain admission above the piston. When the piston frame is elevated, it will raise the water above *D* along with it, and forcing it through the valve, it will be carried off by the spout.

315. An ingenious pump, invented by De la Hire, is represented in fig. 5. It raises water equally quick by the descent as by the ascent of the piston. The pipes *B*, *C*, *E*, *F*, all communicate with the barrel *MD*, and have each a valve at their top, viz. at *b*, *S*, *e*, *f*. The piston rod *LM* and plunger *K* never rise higher than *K*, nor descend lower than *D*, *KD* being the length of the stroke. When the plunger *K* is raised from *D* to *K*, the pressure of the atmosphere forces the water through the valve *b*, and fills the barrel up to the plunger, in the very same way as in the forcing pump. When the plunger *K* is depressed to *D*, it forces the water between *K* and *b* up the pipe *E* and through the valve *e* into the box *G*, where it issues at the orifice *O*. During the descent of the plunger *K* the valve *f* falls, and covers the top of the pipe *F*; and as the piston rod *LM* moves in a collar of leather at *M*, and is air-tight, the air above the plunger, between *Q* and *M*, will be rarefied, and likewise the air in the pipe *CS*, which communicates with the rarefied air by the valve *S*. The pressure of the air therefore will raise the water in *CS*, force it through the valve *S*, and fill the space above the plunger, expelling the rarefied air through the valve *f*. When the piston is raised from *D* to *K*, it will force the water through the bent pipe *F* into the box *G*, so that the same quantity of water will be discharged at *O* through the pipe *F*, during the ascent of the piston, as was discharged through the pipe *E* during the piston's descent. Above the pipe *O* is a close air-vessel *P*, so that when the water is driven above the spout *O*, it compresses the air in the vessel *P*, and this air acting by its elasticity on the surface of the water, forces it out at *O* in a constant and nearly equal stream. As the effect of the machine depends on a proper proportion between the height *O* of the spout above the surface of the well, and the diameter of the barrel, the following table will be of use to the practical mechanic.

Height

On Machines for raising Water.

On Machines for raising Water.

Height of the spout O above the well.		Diameter of the barrel D.	
Feet.	Inches.	Feet.	Inches.
10	6.9	60	2.8
15	5.6	65	2.7
20	4.9	70	2.6
25	4.4	75	2.5
30	4.0	80	2.5
35	3.7	85	2.4
40	3.5	90	2.3
45	3.3	95	2.2
50	3.1	100	2.1

When the proportions in the preceding table are observed, a man of common strength will raise water much higher than he could do with a pump of the common construction.

Noble's pump. Fig. 6.

316. A very simple pump which furnishes a continued stream is represented in fig. 6. It was invented by a Mr Noble, and consists of a working barrel AB with two pistons C and B, which are moved up and down alternately by the rods fixed to the lever EMN. The rod of the piston B passes through the piston C, and the piston C moves upon the rod AB. When the piston rod B is depressed and elevated, it will make the water rise in the barrel A, in the same way as in the sucking pump, whether the valve C be moveable or not. Let us now suppose that the water is raised to A. Then if the piston B is elevated by depressing the extremity N of the lever, the water at A will be raised higher in the barrel, and issue at the spout P, and when the same piston B is depressed by elevating the end N of the lever, the piston C is evidently raised, and the water above it will be expelled at P. This pump, therefore, will give a continued stream, for as the pistons ascend and descend alternately, one of them must always be forcing the water out at P. The pistons are elevated and depressed by means of toothed arches, *c* and *d*, working in the teeth of a rack, at the extremities *a*, *b* of the piston rod.

Buchanan's pump. Fig. 7.

317. The pump invented by Mr Buchanan is shewn in fig. 7. In the vertical section DGA, A is the suction barrel, D the working barrel, E the piston, G the spout, B the inner valve, and C the outer valve. These valves are of the kind called clack valves, and have their hinges generally of metal. It is easily seen that when the piston E is raised, the water will rise through the suction barrel A, into the working barrel D, in the same way as in the sucking pump; and that when the piston E is depressed, it will force the water between it and the valve B, through the valve C, and make it issue at G. The points of difference between this pump and those of the common form, are,—that it discharges the water below the piston, and has its valves lying near each other. Hence the sand or mud which may be in the water, is discharged without injuring the barrel or the piston leathers; and as the valves B, C may be of any size, they will transmit, without being choked, any rubbish which may rise in the suction barrels. If any obstruction should happen to the valves, they are within the reach of the workman's hand, and may be cleared without taking the

pump to pieces. This simple machine may be quickly converted into a fire engine, by adding the air-vessel H, which is screwed like a hosepipe, and by fixing in the spout G a perforated stopple fitted to receive such pipes as are employed in fire engines. When these additions are made, the water, as in the case of the forcing pump, will be driven into the air vessel H, and repelled through the perforated stopple G, by the elasticity of the included air.

On Machines for raising Water.

318. A simple method of working two pumps at once by means of a balance, is exhibited in fig. 8. where AB is the balance, having a large iron ball at each end, placed in equilibrium on the two spindles C, see fig. 9. The person who works the pump stands on two boards I, I, nailed to two cross pieces fastened to the axis of the machine, and supports himself by a cross bar D d joined to the two parts D, E. At the distance of ten inches on each side of the axis are suspended the iron rods M, N, to which the pistons are attached. The workman, by bearing alternately on the right and left foot, puts the balance in motion. The pistons M, N are alternately elevated and depressed, and the water raised in the barrel of each, is driven into the pipe HH, in which it is elevated to a height proportional to the diameter of the valves, and the power of the balance. In order to make the oscillations of the balance equal, and prevent it from acquiring too great a velocity, iron springs F, G are fixed to the upright posts, which limit the length of its oscillations.

319. The chain pump is represented in fig. 1. It consists of a chain MTHG, about 30 feet long, carrying a number of flat pistons M, N, O, P, Q, which are made to revolve in the barrels ABCD and GH, by driving the wheel F. When the flat pistons are at the lower part of the barrel T, they are immersed in the water RR, and as they rise in the barrel GH, they bring up the water along with them into the reservoir MG, from which it is conveyed by the spout S. The teeth of the wheel F are so contrived as to receive one-half of the flat pistons, and let them fold in; and sometimes another wheel like F is fixed at the bottom D. The distance of the pistons from the side of the barrel is about half an inch; but as the machine is generally worked with great velocity, the ascending pistons bring along with them into the reservoir as much water as fills the cavity GH. Sometimes chain pumps are constructed without the barrels ABCD and GH. In this case, the flat pistons are converted into buckets connected with a chain, which dip in the water with their mouths downwards, and convey it to the reservoir. The buckets are moved by hexagonal axles, and the distance between each is nearly equal to the depth of the buckets. Chain pumps are frequently in an inclined position, and in this position they raise the greatest quantity of water when the distance of the flat pistons is equal to their breadth, and when the inclination of the barrels is about 24° 21'.

Chain-pump. Plate CCLXXXII. Fig. 1.

320. The hair-rope machine, invented by the Sicur Vera, operates on the same principle as the chain pump. Instead of a chain of pistons moving round the wheel F, a hair rope is substituted. The part of the rope at T is that is lowest always dips in the water, which adhering to the rope is raised along with it. When the rope reaches the top at G and M, it passes through two small tubes, which being fixed in the bottom of the reservoir

On Machines for raising Water.

Machine with cushions instead of flat pistons.

reservoir prevent the water from returning into the well. Sometimes a common rope is employed, having a number of stuffed cushions fixed to it instead of the flat pistons in the chain pump. These cushions carry the water along with them through the barrel HG, and deliver it into the reservoir.—For the description of other pumps, see the article PUMP; and for pump mills, see the article MILL.

SECT. II. On Engines for Extinguishing Fire.

Common squirting engine.

Fig. 2.

321. The common fire engine which discharges water in successive jets is represented in fig. 2. and is only a modification of the lifting pump. In the vessel AB full of water, is immersed the frame DC of a common lifting pump. This frame, and consequently the piston N, is elevated and depressed by means of the levers E, F, and the water which is raised is forced through the pipe G, which may be moved in any direction by means of the elastic leather pipe H, or by a ball and socket screwed on the top of the pump. While the piston N is descending, the stream at G is evidently discontinued, and issues only at each elevation of the piston. The vessel AB is supplied with water by buckets, and the pump is prevented from being choked by the strainer LK which separates from the water any mud that it may happen to contain.

Improved fire engine.

Fig. 3.

322. As this fire engine does not afford a continued stream, it is not so useful in case of accidents as when the stream is uninterrupted. An improved engine of this sort is represented in fig. 3. where D, E, are two forcing pumps connected with the large vessel OG, and wrought by the levers F, G, moving upon H as a fulcrum. This apparatus is plunged and fastened in the vessel AB partly filled with water, and by means of the forcing pump DE, the operation of which has already been described, the water is driven through the valves I, E into the large vessel OG, where the included air is condensed. Into this vessel is inserted the tube PO communicating with the leathern pipe ORQS. The elasticity of the condensed air in the vessel OG pressing upon the surface of the water in that vessel, forces it up through the tube PO into the leathern pipe, from whose extremity S, it issues with great force and velocity; and as the condensed air is continually pressing upon the water in the vessel OG, the stream at S will be constant and uniform.

Newsham's fire-engine.

Fig. 4.

323. A section of the fire engine, as improved by Mr Newsham, is represented in fig. 4. where TU and WX are the forcing pumps corresponding with D and C in fig. 3. YZ the large vessel corresponding with GO, and *ef* the tube corresponding with PO. The vessels TU, WX, YZ, the horizontal canals ON, QP, ML, and the vertical canal EE, all communicate with each other by means of four valves O, L, K, P opening upwards, and the vertical pipe is immersed in the water to be raised. When the piston R is raised by means of the double lever $\alpha\beta$, a vacuum would be made in the barrel TU, if the water at R were prevented from rising; but as this barrel communicates with the vessel of water below EF, on the surface of which the pressure of the atmosphere is exerted, the water will rise through EF, force open the valve H, and follow the piston R. By depressing the piston R, however, the water is driven down the barrel, closes the valve H, and rushes

through the valve I into the air vessel YZ. The very same operation is going on with the pump WX, which forces the water into the air vessel through the valve K. By these means the air vessel is constantly filling with water, and the included air undergoing continual condensation. The air thus compressed, reacts upon the surface YZ of the water, and forces it through the tube *ef* to the stop-cock *eg*, whence after turning the cock, the water passes into the tube *h*, fixed to a ball and socket, by which it may be discharged in any direction.

324. The fire engine has undergone various alterations and improvements from Bramah, Dickenson, Simpkin, Raventree, Philips and Furst, an account of whose engines may be seen in the Repertory of Arts, &c. A very simple and cheap fire engine has been invented by Mr B. Dearborn, and is described in the American Transactions for 1794, and in Gregory's Mechanics, vol. ii. p. 177.

SECT. III. On Whitehurst's Machine, and Montgolfier's Hydraulic Ram.

325. Mr Whitehurst* was the first who suggested the ingenious idea of raising water by means of its momentum. A machine upon the same principle as Mr Whitehurst's, but in an improved form, has lately made its appearance in France, and excited considerable attention both on the continent and in this country. Whatever credit, therefore, has been given to the inventor of the hydraulic ram, justly belongs to our countryman Mr Whitehurst, and Montgolfier is entitled to nothing more than the merit of an improver.

326. Mr Whitehurst's machine, which was actually erected at Oulton in Cheshire, is represented in fig. 1. where AM is the original reservoir having its surface in the same horizontal line with the bottom of the reservoir BN. The diameter of the main pipe AE is one inch and a half, and its length about 200 yards; and the branch pipe EF is of such a size that the height of the surface M of the reservoir is nearly 16 feet above the cock F. In the valve box D is placed the valve α , and into the air vessel C are inserted the extremities *m, n* of the main pipe, bent downwards to prevent the air from being driven out, when the water is forced into it. Now as the cock F is 16 feet below the reservoir AM, the water will issue from F with a velocity of nearly 30 feet per second. As soon as the cock F therefore is opened, a column of water 200 yards long is put in motion, and though the aperture of the cock F be small, this column must have a very considerable momentum. Let the cock F be now suddenly stopped, and the water will rush through the valve α into the air vessel C, and condense the included air. This condensation must take place every time the cock is shut, and the imprisoned air being in a state of high compression, will react upon the water in the air vessel, and raise it into the reservoir BN.

327. A section of the hydraulic ram of Montgolfier is exhibited in fig. 2. where R is the reservoir, RS the height of the fall, and ST the horizontal canal which conveys the water to the engine ABHTC. E and D are two valves, and FG a pipe reaching within a very little of the bottom CB. Let us now suppose that wa-

On Machines for raising Water.

Refer to the improvement.

Phil. Trans. 1775.

The idea raised by its own momentum first suggested by Mr Whitehurst.

Description of Mr Whitehurst's machine.

Plate CCLXXII fig. 1.

Description of Montgolfier's hydraulic ram. Fig. 2.

On Machines for raising Water.

On Machines for raising Water.

ter is permitted to descend from the reservoir. It will evidently rush out at the aperture mn till its velocity is such as to force up the valve E . The water being thus suddenly checked, and unable to find a passage at mn , will rush forwards to H and raise the valve D . A portion of water being thus admitted into the vessel ABC , the impulse of the column of fluid is spent, the valves D and E fall, and the water issues at mn as before; when its motion is again checked, and the same operation repeated, which has now been described. Whenever, therefore, the valve E closes, a portion of water will force its way into the vessel ABC , and condense the air which it contains, for the included air has no communication with the atmosphere after the bottom of the pipe FG is beneath the surface of the injected water. This condensed air will consequently react upon the surface of the water, and raise it in the pipe FG to an altitude proportioned to the elasticity of the included air. The external appearance of the engine, drawn from one in the possession of Professor Leslie, is represented in fig. 3. where ABC is the air vessel, F the valve box, G the extremity of the valve, and M, N screws for fixing the horizontal canal to the machine. When the engine is employed to form a jet of water, a piece of brass, A , with a small aperture, is screwed upon the top of the tube FG , which, in that case, rises no higher than the top of the air vessel. From this description it will be seen, that the only difference between the engines of Montgolfier and Whitehurst, is, that the one requires a person to turn the cock, while the other has the advantage of acting spontaneously. Montgolfier (G) assures us, that the honour of this invention does not belong to England, but that he is the sole inventor, and did not receive a hint from any person whatever. We leave the reader to determine the degree of credit to which these assertions are entitled.—It would appear from some experiments made by Montgolfier, that the effect of the water ram is equal to between a half and three-fourths of the power expended, which renders it superior to most hydraulic machines. *Appendix to Ferguson's Lectures, p. 19.*

Fig. 3.

SECT. IV. On Archimedes's Screw Engine.

Description of Archimedes's screw-engine.

Fig. 4.

328. THE screw engine invented by Archimedes is represented in fig. 4. where AB is a cylinder with a flexible pipe, $CEHOGF$, wrapped round its circumference like a screw. The cylinder is inclined to the horizon, and supported at one extremity by the bent pillar IR , while its other extremity, furnished with a pivot, is immersed in the water. When, by means of the handle K , the cylinder is made to revolve upon its axis, the water which enters the lower orifice of the flexible pipe is raised to the top, and discharged at D . On some occasions, when the water to be raised moves with a considerable velocity, the engine is put in motion by a number of floatboards fixed at L , and impelled by the current; and if the water is to be raised to a great height, another cylinder is immersed in the vessel D , which receives the water from the first

Operation of the screw engine.

cylinder, and is driven by a pinion fixed at I . In this way, by having a succession of screw engines, and a succession of reservoirs, water may be raised to any altitude. An engine of this kind is described in Ferguson's Lectures, vol. ii. p. 113.

Fig. 5.

329. In order to explain the reason why the water rises in the spiral tube, let AB be a section of the engine, $BCdDE$ the spiral tube, BF a horizontal line or the surface of the stagnant water which is to be raised, and ABC the angle which the axis of the cylinder makes with the horizon. Then, the water which enters the extremity B of the spiral tube will descend to C , and remain there as long as the cylinder is at rest. But if a motion of rotation be communicated to the cylinder, so that the lowest part C of the spiral BCD move towards B , and the points d, D, E towards C , and become successively the lowest parts of the spiral, the water must occupy successively the points d, D, E , and therefore rise in the tube; or, which is the same thing, when the point C moves to c , the point d will be at C ; and as the water at C cannot rise along with the point C to c , on account of the inclination of Cc to the horizon, it must occupy the point d of the spiral, when C has moved to c ; that is, the water has a tendency to occupy the lower parts of the spiral, and the rotatory motion withdraws this part of the spiral from the water, and causes it to ascend to the top of the tube. By wrapping a cord round the cylinder, and inclining it to the horizon, so that the angle ABC may be greater than the angle ABF , and then making it revolve upon its axis, the preceding remarks will be clearly illustrated.—If the direction of the spiral BC should be horizontal, that is, if it should coincide with the line BF , the water will have no tendency to move towards C , and therefore cannot be raised in the tube. For a similar reason, it will not rise when the point C is above the horizontal line BF . Consequently, in the construction of this engine, the angle ABC , which the spiral forms with the side of the cylinder, must always be greater than the angle ABF , at which the cylinder is inclined to the horizon. In practice, the angle of inclination ABF should generally be about 50° , and the angle ABC about 65° .

330. The theory of this engine is treated at great length by Hennert, in his *Dissertation sur la vis d'Archimede*, Berlin 1767; by Pitot, in the Memoirs of the French Academy, and by Euler in the *Nov. Comment. Petrop.* tom. v. An account of Pitot's investigations may be seen in Gregory's *Mechanics*, vol. ii. p. 348.

SECT. V. On the Persian Wheel.

331. THE Persian wheel is an engine which raises water to a height equal to its diameter. It is shewn in fig. 6. where CDE is the wheel driven by the stream AB acting upon floatboards fixed on one side of its rim. A number of buckets, a, a, a, a , are disposed on the opposite side of the rim, and suspended by strong pins, b, b, b, b , &c. When the wheel is in motion, the descending buckets immerse into the stream, and ascend full

Fig. 6.

(G) Cette invention n'est point originaire d'Angleterre, elle appartient toute entiere à la France. Je declare que j'en suis le seul inventeur, et que l'idée ne m'en a été fournie par personne. JOURNAL DES MINES, vol. xiii. N° 73.

On Machines for raising Water.

full of water till they reach the top K, where they strike against the extremity *n* of the fixed reservoir M, and being overset, discharge their contents into that reservoir. As soon as the bucket quits the reservoir, it resumes its perpendicular position by its own weight, and descends as before. On each bucket is fixed a spring *r*, which moves over the top of the bar *m*, fastened to the reservoir. By this means the bottom of the bucket is raised above the level of its mouth, and its contents completely discharged.

332. On some occasions the Persian wheel is made to raise water only to the height of its axle. In this case, instead of buckets, its spokes *c, d, e, f, g, h*, are made of a spiral form, and hollow within, so that their inner extremities all terminate in the box N on the axle, and their outer extremities in the circumference of the wheel. When the rim CDEF, therefore, is immersed in the stream, the water runs into the tubes C, D, E, F, &c. rises in the spiral spokes *c, d*, &c. and is discharged from the orifices at O into the reservoir Q, from which it may be conveyed in pipes.

SECT. VI. On the Zurich Machine.

333. THIS machine is a kind of pump invented and erected by H. Andreas Wirtz, an ingenious tin-plate worker in Zurich, and operates on a principle different from all other hydraulic engines. The following description of it, written by Dr Robison, is transferred to this part of the work for the sake of uniformity.

Plate
LXXIV.
fig. 7.

334. Fig. 7. is a sketch of the section of the machine, as it was first erected by Wirtz at a dye-house in Limmat, in the suburbs or vicinity of Zurich. It consists of a hollow cylinder, like a very large grindstone, turning on a horizontal axis, and partly plunged in a cistern of water. The axis is hollow at one end, and communicates with a perpendicular pipe CBZ, part of which is hid by the cylinder. This cylinder or drum is formed into a spiral canal by a plate coiled up within it like the main spring of a watch in its box; only the spires are at a distance from each other, so as to form a conduit for the water of uniform width. This spiral partition is well joined to the two ends of the cylinder, and no water escapes between them. The outermost turn of the spiral begins to widen about three-fourths of a circumference from the end, and this gradual enlargement continues from Q to S nearly a semicircle: this part may be called the HORN. It then widens suddenly, forming a SCOOP or shovel SS'. The cylinder is supported so as to dip several inches into the water, whose surface is represented by VV'.

335. When this cylinder is turned round its axis in the direction ABEO, as expressed by the two darts, the scoop SS' dips at V' and takes up a certain quantity of water before it immerses again at V. This quantity is sufficient to fill the taper part SQ, which we have called the HORN; and this is nearly equal in capacity to the outermost uniform spiral round.

336. After the scoop has emerged, the water passes along the spiral by the motion of it round the axis, and drives the air before it into the rising-pipe, where it escapes.—In the mean time, air comes in at the mouth of the scoop; and when the scoop again dips into the water, it again takes in some. Thus there is now a

part filled with water and a part filled with air. Continuing this motion, we shall receive a second round of water and another of air. The water in any turn of the spiral will have its two ends on a level; and the air between the successive columns of water will be in its natural state; for since the passage into the rising pipe or MAIN is open, there is nothing to force the water and air into any other position. But since the spires gradually diminish in their length, it is plain that the column of water will gradually occupy more and more of the circumference of each. At last it will occupy a complete turn of some spiral that is near the centre; and when sent farther in, by the continuance of the motion, some of it will run back over the top of the succeeding spiral. Thus it will run over at K 4 into the right-hand side of the third spiral. Therefore it will push the water of this spire backwards, and raise its other end, so that it also will run over backwards before the next turn be completed. And this change of disposition will at last reach the first or outermost spiral, and some water will run over into the horn and scoop, and finally into the cistern.

337. But as soon as water gets into the rising pipe, and rises a little in it, it stops the escape of the air when the next scoop of water is taken in. Here are now two columns of water acting against each other by hydrostatic pressure and the intervening column of air. They must compress the air between them, and the water and air-columns will now be unequal. This will have a general tendency to keep the whole water back, and cause it to be higher on the left or rising side of each spire than on the right descending side. The excess of height will be just such as produces the compression of the air between that and the preceding column of water. This will go on increasing as the water mounts in the rising pipe; for the air next to the rising pipe is compressed at its inner end with the weight of the whole column in the main. It must be as much compressed at its outer end. This must be done by the water column without it; and this column exerts this pressure partly by reason that its outer end is higher than its inner end, and partly by the transmission of the pressure on its outer end by air, which is similarly compressed from without. And thus it will happen that each column of water, being higher at its outer than at its inner end, compresses the air on the water column beyond or within it, which transmits this pressure to the air beyond it, adding to it the pressure arising from its own want of levels at the ends. Therefore the greatest compression, viz. that of the air next the main, is produced by the sum of all the transmitted pressures; and these are the sum of all the differences between the elevations of the inner ends of the water columns above their outer ends: and the height to which the water will rise in the main will be just equal to this sum.

338. Draw the horizontal lines K'K 1, K'K 2, K'K 3, &c. and *m n, m n, m n*, &c. Suppose the left-hand spaces to be filled with water, and the right-hand spaces to be filled with air. There is a certain gradation of compression which will keep things in this position. The spaces evidently decrease in arithmetical progression; so do the hydrostatic heights and pressures of the water columns. If therefore the air be dense in the same progression, all will be in hydrostatical equilibrium.

Now

On Ma-
chine: for
raising
Water.

On Ma-
chine: for
raising
Water.

Plate
CCLXXIV
fig. 7.

Now this is evidently producible by the mere motion of the machine; for since the density and compression in each air column is supposed inversely as the bulk of the column, the absolute quantity of air is the same in all; therefore the column first taken in will pass gradually inwards, and the increasing compression will cause it to occupy precisely the whole right-hand side of every spire. The gradual diminution of the water columns will be produced during the motion by the water running over backwards at the top, from spire to spire, and at last coming out by the scoop.

339. It is evident that this disposition of the air and water will raise the water to the greatest height, because the hydrostatic height of each water column is the greatest possible, viz. the diameter of the spire. This disposition may be obtained in the following manner: Take CL to CB as the density of the external air to its density in the last column next the rising-pipe or main; that is, make CL to CB as 33 feet (the height of the column of water which balances the atmosphere), to the sum of 33 feet and the height of the rising-pipe. Then divide BL into such a number of turns, that the sum of their diameters shall be equal to the height of the main; then bring a pipe straight from L to the centre C. The reason of all this is very evident.

340. But when the main is very high, this construction will require a very great diameter of the drum, or many turns of a very narrow pipe. In such cases it will be much better to make the spiral in the form of a cork-screw, as in fig. 1. instead of this flat form like a watch spring. The pipe which forms the spiral may be lapped round the frustum of a cone, whose greatest diameter is to the least (which is next to the rising pipe) in the same proportion that we assigned to CB and CL. By this construction the water will stand in every round so as to have its upper and lower surfaces tangents to the top and bottom of the spiral, and the water columns will occupy the whole ascending side of the machine, while the air occupies the descending side.

Plate
CCLXXV.
fig. 1.

341. This form is vastly preferable to the flat: it will allow us to employ many turns of a large pipe, and therefore produce a great elevation of a large quantity of water.

The same thing will be still better done by lapping the pipe on a cylinder, and making it taper to the end, in such a proportion that the contents of each round may be the same as when it is lapped round the cone. It will raise the water to a greater height (but with an increase of the impelling power) by the same number of turns, because the vertical or pressing height of each column is greater.

Nay, the same thing may be done in a more simple manner, by lapping a pipe of uniform bore round a cylinder. But this will require more turns, because the water columns will have less differences between the heights of their two ends. It requires a very minute investigation to show the progress of the columns of air and water in this construction, and the various changes of their arrangement, before one is attained which will continue during the working of the machine.

342. We have chosen for the description of the machine that construction which made its principle and

manner of working most evident, namely, which contained the same material quantity of air in each turn of the spiral, more and more compressed as it approaches to the rising pipe. We should otherwise have been obliged to investigate in great detail the gradual progress of the water, and the frequent changes of its arrangement, before we could see that one arrangement would be produced which would remain constant during the working of the machine. But this is not the best construction. We see that, in order to raise water to the height of a column of 34 feet, which balances the atmosphere, the air in the last spire is compressed into half its bulk; and the quantity of water delivered into the main at each turn is but half of what was received into the first spire, the rest flowing back from spire to spire, and being discharged at the spout.

343. But it may be constructed so as that the quantity of water in each spire may be the same that was received into the first; by which means a greater quantity (double in the instance now given) will be delivered into the main, and raised to the same height by very nearly the same force.—This may be done by another proportion of the capacity of the spires, whether by a change of their caliber or of their diameters. Suppose the bore to be the same, the diameter must be made such that the constant column of water, and the column of air, compressed to the proper degree, may occupy the whole circumference. Let A be the column of water which balances the atmosphere, and h the height to which the water is to be raised. Let A be to A+h as 1 to m.

344. It is plain that m will represent the density of the air in the last spire, if its natural density be 1, because it is pressed by the column A+h, while the common air is pressed by A. Let 1 represent the constant water column, and therefore nearly equal to the air column in the first spire. The whole circumference of the last spire must be $1 + \frac{1}{m}$, in order to hold the wa-

ter 1, and the air compressed into the space $\frac{1}{m}$ or $\frac{A}{A+h}$.

345. The circumference of the first spire is $1 + 1$ or 2. Let D and d be the diameters of the first and last spires; we have $2 : 1 + \frac{1}{m} = D : d$, or $2m : m + 1 =$

D : d. Therefore if a pipe of uniform bore be lapped round a cone, of which D and d are the end diameters, the spirals will be very nearly such as will answer the purpose. It will not be quite exact, for the intermediate spirals will be somewhat too large. The conoidal frustum should be formed by the revolution of a curve of the logarithmic kind. But the error is very trifling.

With such a spiral, the full quantity of water which was confined in the first spiral will find room in the last, and will be sent into the main at every turn. This is a very great advantage, especially when the water is to be much raised. The saving of power by this change of construction is always in proportion to the greatest compression of the air.

The great difficulty in the construction of any

On Ma-
chines for
raising
Water.

Plate
CCLXXV.
fig. 2.

of these forms is in determining the form and position of the horn and the scoop; and on this greatly depends the performance of the machine. The following instructions will make it pretty easy.

346. Let ABEO (fig. 2.) represent the first or outermost round of the spiral, of which the axis is C. Suppose it immersed up to the axis in the water VV, we have seen that the machine is most effective when the surfaces KB and O π of the water columns are distant the whole diameter BO of the spiral. Therefore let the pipe be first supposed of equal calibre to the very mouth Ee, which we suppose to be just about to dip into the water. The surface O π is kept there, in opposition to the pressure of the water column BAO, by the compressed air contained in the quadrant OE, and in the quadrant which lies behind EB. And this compression is supported by the columns behind, between this spire and the rising pipe. But the air in the outermost quadrant EB is in its natural state, communicating as yet with the external air. When, however, the mouth Ee has come round to A, it will not have the water standing in it in the same manner, leaving the half space BEO filled with compressed air; for it took in and confined only what filled the quadrant BE. It is plain, therefore, that the quadrant BE must be so shaped as to take in and confine a much greater quantity of air; so that when it has come to A, the space BEO may contain air sufficiently dense to support the column AO. But this is not enough: For when the wide mouth, now at Aa, rises up to the top, the surface of the water in it rises also, because the part AOoa is more capacious than the cylindrical part OEeo which succeeds it, and which cannot contain all the water that it does. Since, then, the water in the spire rises above A, it will press the water back from O π to some other position m'n', and the pressing height of the water-column will be diminished by this rising on the other side of O. In short, the horn must begin to widen, not from B, but from A, and must occupy the whole semicircle ABE; and its capacity must be to the capacity of the opposite cylindrical side as the sum of BO, and the height of a column of water which balances the atmosphere to the height of that column. For then the air which filled it, when of the common density, will fill the uniform side BEO, when compressed so as to balance the vertical column BO. But even this is not enough; for it has not taken in enough of water. When it dipped into the cistern at E, it carried air down with it, and the pressure of the water in the cistern caused the water to rise into it a little way; and some water must have come over at B from the other side, which was drawing narrower. Therefore when the horn is in the position EOA, it is not full of water. Therefore when it comes into the situation OAB, it cannot be full nor balance the air on the opposite side. Some will therefore come out at O, and rise up through the water. The horn must therefore, 1st, Extend at least from O to B, or occupy half the circumference; and, 2dly, It must contain at least twice as much water as would fill the side BEO. It will do little harm though it be much larger; because the surplus of air which it takes in at E will be discharged, as the end Ee of the horn rises from O to B, and it will leave the precise quantity that is wanted. The overplus water will be discharged as the horn comes

2.

round to dip again into the cistern. It is possible, but requires a discussion too intricate for this place, to make it of such a size and shape, that while the mouth moves from E to B, passing through O and A, the surface of the water in it shall advance from E π to O π , and be exactly at O when the beginning or narrow end of the horn arrives there.

347. We must also secure the proper quantity of water. When the machine is so much immersed as to be up to the axis in water, the capacity which thus secures the proper quantity of air will also take in the proper quantity of water. But it may be erected so as that the spirals shall not even reach the water. In this case it will answer our purpose if we join to the end of the horn a scoop or shovel QRSB (fig. 3.), which is so formed as to take in at least as much water as will fill the horn. This is all that is wanted in the beginning of the motion along the spiral, and more than is necessary when the water has advanced to the succeeding spire; but the overplus is discharged in the way we have mentioned. At the same time, it is needless to load the machine with more water than is necessary, merely to throw it out again. We think that if the horn occupies fully more than one-half of the circumference, and contains as much as will fill the whole round, and if the scoop lifts as much as will certainly fill the horn, it will do very well.

N. B. The scoop must be very open on the side next the axis, that it may not confine the air as soon as it enters the water. This would hinder it from receiving water enough.

348. The following dimensions of a machine erected at Florence, and whose performance corresponded extremely well with the theory, may serve as an example.

The spiral is formed on a cylinder of 10 feet diameter, and the diameter of the pipe is six inches. The smaller end of the horn is of the same diameter; it occupies three-fourths of the circumference, and is $7\frac{1}{2}$ inches wide at the outer end. Here it joins the scoop, which lifts as much water as fills the horn, which contains 4340 Swedish cubic inches, each = 1.577 English. The machine makes six turns in a minute, and raises 1354 pounds of water, or 22 cubic feet, 10 feet high in a minute.

349. The above account will, we hope, sufficiently explain the manner in which this singular hydraulic machine produces its effect. When every thing is executed by the maxims which we have deduced from its principles, we are confident that its performance will correspond to the theory; and we have the Florentine machine as a proof of this. It raises more than ten-elevenths of what the theory promises, and it is not perfect. The spiral is of equal caliber, and is formed on a cylinder. The friction is so inconsiderable in this machine, that it need not be minded: but the great excellency is, that whatever imperfection there may be in the arrangement of the air and water columns, this only affects the elegance of the execution, causing the water to make a few more turns in the spiral before it can mount to the height required; but wastes no power, because the power employed is always in proportion to the sum of the vertical columns of water in the rising side of the machine; and the height to which the water is raised by it is in the very same proportion. It should

be.

On Ma-
chines for
raising
Water.

Plate
CCLXXV.
fig. 3.

On Machines for raising Water.

Water Blowing Machine.

be made to move very slow, that the water be not always dragged up by the pipes, which would cause more to run over from each column, and diminish the pressure of the remainder.

screws, such as *gg*, which go into holes in the plate *ff*, and thus draw the two plates *ff* and *dd* together, with the plate *ee* between them. Pieces of thin leather are put on each side of *ee*; and thus all escape of water is effectually prevented, with a very moderate compression and friction.

350. If the rising-pipe be made wide, and thus room be made for the air to escape freely up through the water, it will rise to the height assigned; but if it be narrow, so that the air cannot get up, it rises almost as slow as the water, and by this circumstance the water is raised to a much greater height mixed with air, and this with hardly any more power. It is in this way that we can account for the great performance of the Florentine machine, which is almost triple of what a man can do with the finest pump that ever was made: indeed the performance is so great, that one is apt to suspect some inaccuracy in the accounts. The entry into the rising-pipe should be no wider than the last part of the spiral; and it would be advisable to divide it into four channels by a thin partition, and then to make the rising-pipe very wide, and to put into it a number of slender rods, which would divide it into slender channels that would completely entangle the air among the water. This will greatly increase the height of the heterogeneous column. It is surprising that a machine that is so very promising should have attracted so little notice. We do not know of any being erected out of Switzerland, except at Florence in 1778. The account of its performance was in consequence of a very public trial in 1779, and honourable declaration of its merit, by Sig. Lorenzo Ginori, who erected another, which fully equalled it. It is shortly mentioned by Professor Sulzer of Berlin, in the *Sammlungen Vermischten Schriften* for 1754. A description of it is published by the Philosophical Society at Zurich in 1766, and in the descriptions published by the Society in London for the encouragement of Arts in 1776. The celebrated Daniel Bernouilli has published a very accurate theory of it in the *Petersburgh Commentaries* for 1772, and the machines at Florence were erected according to his instructions. Baron Alstromer in Sweden caused a glass model of it to be made, to exhibit the internal motions for the instruction of artists, and also ordered an operative engine to be erected; but we have not seen any account of its performance. It is a very intricate machine in its principles; and an ignorant engineer, nay the most intelligent, may erect one which shall hardly do any thing; and yet by a very trifling change, may become very powerful. We presume that failures of this kind have turned the attention of engineers from it; but we are persuaded that it may be made very effective, and we are certain that it must be very durable. Fig. 4. is a section of the manner in which the author has formed the communication between the spiral and the rising pipe. P is the end of the hollow axis which is united with the solid iron axis. Adjoining to P, on the under side, is the entry from the last turn of the spiral. At Q is the collar which rests on the supports, and turns round in a hole of bell-metal. *ff* is a broad flanch cast in one piece with the hollow part. Beyond this the pipe is turned somewhat smaller, very round and smooth, so as to fit into the mouth of the rising-pipe, like the key of a cock. This mouth has a plate *ee* attached to it. There is another plate *dd*, which is broader than *ee*, and is not fixed to the cylindrical part, but moves easily round it. In this plate are four

CHAP. IV. On Machines in which Water is the chief Agent.

SECT. I. On the Water Blowing Machine.

351. THE water blowing machine consists of a reservoir of water AB, into the bottom of which the bent leaden pipe BCH is inserted; of a condensing vessel DE, into whose top the lower extremity H of the pipe is fixed, and of a pedestal P resting on the bottom of this vessel. When the water from the reservoir AB is descending through the part CH of the pipe, it is in contact with the external air by means of the orifices or tubes *m, n, o, p*; and by the principle of the lateral communication of motion in fluids (art. 160.), the air is dragged along with the water. This combination of air and water issuing from the aperture H, and impinging upon the surface of the stone pedestal P, is dispersed in various directions. The air being thus separated from the water, ascends into the upper part of the vessel, and rushes through the opening F, whence it is conveyed by the pipe FG to the fire at G, while the water falls to the lower part of the vessel, and is discharged by the openings M, N.—That the greatest quantity of air may be driven into the vessel DE, the water should begin to fall at C with the least possible velocity; and the height of the lowest tubes above the extremity H of the pipe should be three-elevenths of the length of the vertical tube CH, in order that the air may move in the pipe FG with sufficient velocity.

Description of the water blowing machine. Plate CCLXXV. fig. 5.

352. Fabri and Dietrich imagined that the wind is produced by the decomposition of the water, or its transformation into gas, in consequence of the agitation and percussion of its parts. But M. Venturi, to whom we owe the first philosophical account of this machine, has shewn that this opinion is erroneous, and that the wind is supplied from the atmosphere, for no wind was generated when the lateral openings *m, n, o, p* were shut. The principal object, therefore, in the construction of water blowing machines, is to combine as much air as possible with the descending current. For this purpose the water is often made to pass through a kind of cullender placed in the open air, and perforated with a number of small triangular orifices. Through these apertures the water descends in many small streams; and by exposing a greater surface to the atmosphere, it carries along with it an immense quantity of air. The water is then conveyed to the pedestal P by a pipe CH opened and enlarged at C, so as to be considerably wider than the end of the tube which holds the cullender.

353. It has been generally supposed that the water-fall should be very high; but Dr Lewis has shewn, by a variety of experiments, that a fall of four or five feet is sufficient, and that when the height is greater than this, two or more blowing machines may be erected, by conducting the water from which the air is extricated, into another reservoir, from which it again descends, and

Plate CCLXXV. fig. 4.

Bramah's Press. generates air as formerly. In order that the air which is necessarily loaded with moisture, may arrive at the furnace in as dry a state as possible, the condensing vessel DE should be made as high as circumstances will permit; and in order to determine the strength of the blast, it should be furnished with a gage *a b* filled with water.

Cause of the rain wind.

354. The rain wind is produced in the same way as the blast of air in water blowing machines. When the drops of rain impinge upon the surface of the sea, the air which they drag along with them often produces a heavy squall, which is sufficiently strong to carry away the mast of a ship. The same phenomenon happens at land, when the clouds empty themselves in alternate showers. In this case, the wind proceeds from that quarter of the horizon where the shower is falling. The common method of accounting for the origin of the winds by local rarefaction of the air appears pregnant with insuperable difficulties; and there is reason to think that these agitations in our atmosphere ought rather to be referred to the principle which we have now been considering. For farther information on this subject, the reader is referred to Lewis's *Commerce of Arts*, *Wolff's Opera Mathematica*, tom. i. p. 830. *Journal des Mines*, N^o xci. or Nicholson's *Journal*, vol. xii. p. 48.

SECT. II. Bramah's Hydrostatic Press.

Description of Bramah's machine.

Plate CCLXXXV. fig. 6.

355. THE machine invented by Mr Bramah of Piccadilly, depends upon the principle, that any pressure exerted upon a fluid mass is propagated equally in every direction, (art. 111.). It is represented in fig. 6. where A is a strong metallic cylinder, furnished with a piston B perfectly water-tight. Into the bottom of this cylinder is inserted the end of the bent tube C, the interior orifice of which is closed by the valve D. The other extremity of the tube communicates with the forcing pump E, by which water or other fluids may be driven into the cylinder A. Then, if any pressure is exerted on the surface of the water in the cylinder E by means of the lever H, this pressure will be propagated to the cylinder A, and exert a certain force upon the piston B, varying with the respective areas of the sections of each cylinder. If the diameter of the cylinder E is equal to the diameter of the cylinder A, and if a force of 10 pounds is exerted at the handle H, then the piston B will be elevated with a force of 10 pounds; if the diameter of E be one-half that of A, the piston B will be raised with a force of 40 pounds, because the area of the one piston is four times the area of the other. Or, in general, if D be the diameter of the cylinder A, *d* that of the cylinder E, and F the force exerted at the lever H, we shall have $d^2 : D^2 :: F : \frac{F \times D^2}{d^2}$, which is the force exerted upon the piston B.

Thus, if $d = 2$ inches, $D = 24$ inches, and $F = 10$ pounds, then $\frac{F \times D^2}{d^2} = \frac{10 \times 24 \times 24}{2 \times 2} = 1440$ pounds, the force with which the piston B is elevated. Now, as this force increases as d^2 diminishes, or as F and D^2 increase, there is no limit to the power of the engine; for the diameter of the cylinder A may be made of any size, and that of the cylinder E exceedingly small, while the power may be still farther augmented by

lengthening the lever H. The same effects may be produced by injecting air into the pipe C by means of a large globe fixed at its extremity. Upon the same principles the power and motion of one machine may be communicated to another; for we have only to connect the two machines by means of a pipe filled with water, inverted at each extremity into a cylinder furnished with a piston. By this means the power which depresses one of the pistons will be transferred along the connecting pipe, and will elevate the other piston. In the same way water may be raised out of wells of any depth, and at any distance from the place where the power is applied; but we must refer the reader, for a detailed account of these applications, to the specification of the patent obtained by Mr Bramah, or to Gregory's *Mechanics*, vol. ii. p. 120.

SECT. III. On Clepsydræ or Water-Clocks.

356. A clepsydra or water-clock, derived from History of *κλεψτρον*, "to steal," and *ὕδωρ*, "water," is a machine *clepsydra* which measures time by the motion of water (art. 159.) The invention of this machine has been ascribed to Scipio Nasica, the cousin of Scipio Africanus, who flourished about 200 years before the Christian era. It was well known, however, at an earlier period, among the Egyptians, who employed it to measure the course of the sun. It is highly probable that Scipio Nasica had only the merit of introducing it into his native country. These machines were in use for a very long period, and continued to be employed as measurers of time till the invention of the pendulum clock enriched the arts and sciences.

357. The clepsydra, invented by Ctesibius of Alex-*The clep-* andria, was an interesting machine. The water which *sydra* of *Ctesibius* indicated the progress of time by the gradual descent of its surface, flowed in the form of tears from the eyes of a human figure. Its head was bent down with age: Its look was dejected, while it seemed to pay the last tribute of regret to the fleeting moments as they passed. —The water which was thus discharged was collected in a vertical reservoir, where it raised another figure holding in its hand a rod, which, by its gradual ascent, pointed out the hours upon a vertical column. The same fluid was afterwards employed in the interior of the pedestal, as the impelling power of a piece of machinery which made this column revolve round its axis in a year, so that the months and the days were always shewn by this index, whose extremity described a vertical line divided according to the relative lengths of the hours of day and night. Among the ancients the length of the hours varied every day, and even the hours of the day differed in length from those of the night: for the length of the day, or the interval between sunrise and sunset, was always divided into *twelve* equal parts, while the length of the night, or the interval between sunset and sunrise, was divided into the same number of parts, for hours. A farther description of this beautiful machine, and others of the same nature, may be seen in Ferrault's *Vitruvius*.

358. The method of constructing clepsydræ, when the vessel from which the fluid issues is cylindrical or of any other form, has been shewn in Prop. VII. Part II. Instead of dividing the sides of the vessel, for a scale to ascertain the descent of the fluid surface, the following

Clepsydra. following method may be adopted. In the bottom of the cylindrical vessel ABCD, which is about 12 inches high, and four inches in diameter, is inserted a small glass adjutage E, which discharges the water in the vessel by successive drops. A hole F, about half an inch in diameter, is perforated in the cover AB, so as to allow the glass tube GI, about 16 inches long, and half an inch in diameter, to move up and down without experiencing any resistance. To the extremity of this tube is attached the ball I, which floats on the surface of the water in the vessel, and is kept steady, either by introducing a quantity of mercury into its cavity, if it be hollow, or by suspending a weight if it is a solid which does not sink in water. When the vessel is filled with water, the ball I will be at the top AB; then, in order to graduate the tube C, let the water flow out at E, and by means of a watch mark the points on the tube which descend to F after the lapse of every hour, every half hour, and every quarter, and the instrument will be finished. In order to use this hydroscope or water-clock, pour water into the vessel ABCD till the hour of the day is about to descend below F; and when this is done, it will point out any succeeding hour till the vessel is emptied.

Fig. 3.

Hamilton's Clepsydra. 359. The clepsydra, invented by the honourable Mr Charles Hamilton, is represented in fig. 7. An open canal *ec*, supplied with a constant and equal stream by the syphon *d*, has at each end *ff*, open pipes *f1*, *f2* of exactly equal bores, which deliver the water that runs along the canal *e*, alternately into the vessels *g1*, *g2*, in such a quantity as to raise the water from the mouth of the tantalus *t*, exactly in an hour. The canal *ec* is equally poised by the two pipes *f1*, *f2*, upon a centre *r*; the ends of the canal *e* are raised alternately, as the cups *xx* are depressed, to which they are connected by lines running over the pulleys *ll*. The cups *xx* are fixed at each end of the balance *mm*, which moves up and down upon its centre *v*. *n1*, *n2*, are the edges of two wheels or pulleys, moving different ways alternately, and fitted to the cylinder *o* by oblique teeth both in the cavity of the wheel and upon the cylinder, which, when the wheel *n* moves one way, that is, in the direction of the minute-hand, meet the teeth of the cylinder and carry the cylinder along with it, and slip over those of the cylinder when *n* moves the contrary way, the teeth not meeting, but receding from each other. One or other of these wheels *nn* continually moves *o* in the

same direction, with an equable and uninterrupted motion. A fine chain goes twice round each wheel, having at one end a weight X, always out of the water, which equiponderates with *y* at the other end, and, when kept floating on the surface of the fluid in the vessel *g*, which *y* must always be; the two cups *xx*, one at each end of the balance, keep it in equilibrio, till one of them is forced down by the weight and impulse of the water, which it receives from the tantalus *t*. Each of these cups *xx*, has likewise a tantalus of its own *h*, *h*, which empties it after the water has run from *g*, and leaves the two cups again in equilibrio: *g* is a drain to carry off the water. The dial-plate, &c. needs no description. The motion of the clepsydra is effected thus: As the end of the canal *ec*, fixed to the pipe *f1*, is the lowest in the figure, all the water supplied by the syphon runs through the pipe *f1*, into the vessel *g1*, till it runs over the top of the tantalus *t*; when it immediately runs out at *t* into the cup Z, at the end of the balance *m*, and forces it down; the balance moving on its centre *v*. When one side of *m* is brought down, the string which connects it to *f1*, running over the pulley *l*, raises the end *f1*, of the canal *e*, which turns upon its centre *r*, higher than *f2*; consequently, all the water which runs through the syphon *d* passes through *f2* into *g2*, till the same operation is performed in that vessel, and so on alternately. As the height to which the water rises in *g* in an hour, viz. from *S* to *t*, is equal to the circumference of *n*, the float *y* rising through that height along with the water, allows the weight X to act upon the pulley *n*, which carries with it the cylinder *o*; and this, making a revolution, causes the index *k* to describe an hour on the dial-plate. This revolution is performed by the pulley *n1*; the next is performed by *n2*, whilst *n1* goes back, as the water in *g1* runs out through the tantalus; for *y* must follow the water, as its weight increases, out of it. The axis *o* always keeps moving the same way; the index *p* describes the minutes; each tantalus must be wider than the syphon, that the vessels *gg* may be emptied as low as *s*, before the water returns to them.

360. For farther information respecting subjects connected with hydrodynamics, see the articles *FLOATING Bodies*, *MECHANICS*, *MILL*, *PUMP*, *RESISTANCE of Fluids*, *RIVER*, *SPECIFIC Gravity*, *SHIP-Building*, and *WATER-Works*.

Clepsydra.

INDEX.

<p>A</p> <p>CHARD's experiments on capillary attraction, N^o 130</p> <p>Adulteration in metals, how to detect it, 87</p> <p>Archimedes's method, 88</p> <p>Archimedes resolves the problem of Hiero, <i>ib.</i></p> <p>screw engine, 328</p> <p>Barometer, 99</p> <p>Deparcieux's, 108</p>	<p>Atmosphere, pressure of, discovered by Pascal, N^o 8</p> <p>Attraction, capillary, 112</p> <p>attempt to explain it, 113</p> <p>phenomena of, 114, &c.</p> <p style="text-align: center;">B</p> <p>Balance pump, 318</p> <p>Barker's mill, 300</p> <p>Barometer, construction of, 72</p> <p>Bellows, hydrostatic, 51</p>	<p>Bernoulli, Daniel, his theory of the motion of fluids, N^o 15</p> <p>John, on the motion of fluids, 16</p> <p>Blowing machine, 355</p> <p>Bossut makes numerous experiments on the motion of fluids, 19</p> <p>Bramah's hydrostatic press, 355</p> <p>Breast wheels, 268</p> <p>table for, 269</p> <p>dimensions of, 275</p>
--	--	---

<i>Buat</i> , Chevalier, makes accurate experiments on the motion of water, N° 22	
classes the experiments formerly made,	21
<i>Buchanan's</i> pump,	317
C	
<i>Canals</i> , velocity of water in,	214
<i>Canton</i> on the compressibility of fluids,	29
<i>Capillary</i> attraction,	112
<i>Jurin's</i> explanation of,	114
<i>Dr Hamilton's</i> ,	117
<i>Dr Young's</i> ,	ib.
<i>Laplace's</i> ,	127
<i>Achard's</i> experiments on,	130
<i>Morveau's</i> experiments on,	131
<i>Count Rumford's</i> ,	133
<i>Castelli</i> explains several hydraulic phenomena,	7
<i>Centre</i> of pressure, of percussion,	47
<i>Chain</i> pump,	319
<i>Clepsydræ</i> , history of,	356
<i>Ctesibius's</i> ,	357
<i>Hamilton's</i> ,	359
theory and construction of,	159
<i>Communicating</i> vessels, the surface of water in them horizontal,	37
<i>Conduit</i> pipes, pressure which they sustain,	168
experiments on the motion of water in,	203
table of the quantities which they discharge,	204
<i>Cones</i> , resistance which they sustain in fluids,	239
<i>Coulomb's</i> experiments on the resistance of fluids,	221
<i>Couplet's</i> experiments on the motion of water in conduit pipes,	211
<i>Ctesibius</i> invents the forcing pump, his pump,	309
his clepsydra,	357
<i>Cylinders</i> , resistance which they sustain in fluids,	236—239
D	
<i>D'Alembert</i> applies his principle of dynamics to the motion of fluids,	17
<i>Deparcieux's</i> areometer, experiments on overshot wheels,	108
260	
<i>Dicus's</i> hydrometer,	105
<i>Dykes</i> , on the construction of, to find the dimensions of,	57 & 66
E	
<i>Egyptian</i> wheel,	4
<i>Engines</i> for extinguishing fire,	321

<i>Euler</i> , Albert, on overshot wheels, N° 267 his machine driven by the reaction of water,	304
on the motion of fluids,	17
<i>Exhaustion</i> of vessels, theory of, 155—157 experiments on,	194
<i>Eytelwein's</i> experiments on the motion of fluids,	178

F

<i>Fahrenheit's</i> hydrometer,	100
<i>Fire-engine</i> , common squirting, improved,	321
<i>Newsbam's</i> ,	322
323	
<i>Flaugergues</i> on the oscillation of waves,	20
<i>Floating</i> bodies, equilibrium of, 73—82 apparent attraction and repulsion of,	132
<i>Fluids</i> , perfect and imperfect, pressure and equilibrium of, experiments for illustrating it, compressibility of, cohesion of, theory of the motion of, experiments on the motion of, oscillation of, in a vertical syphon,	250
press equally in every direction,	32
surface of, always horizontal,	34
pressure of, on the bottom and sides of the vessels,	43—46
immiscible, equilibrium of,	71
quantity of, discharged from orifices,	151
lateral communication of motion in,	150
<i>Forcing</i> pump,	313
<i>Frontinus's</i> work on the Roman aqueducts, and on the motion of fluids,	5

G

<i>Galileo</i> lays the foundation of hydraulics by discovering the uniform acceleration of gravity,	6
<i>Globes</i> , resistance which they sustain in fluids,	239, 241
<i>Gravimeter</i> ,	99
<i>Gravities</i> , specific,	70, 111

H

<i>Hair-rope</i> machine,	320
<i>Hamilton's</i> clepsydra,	359
<i>Hemispheres</i> , resistance which they sustain in fluids,	239, 247
<i>Hiero</i> invents the fountain of compression,	4
<i>Hiero's</i> problem,	88
<i>Hire's</i> , <i>De la</i> , pump,	315
<i>Horizontal</i> wheels, with curvilinear float-boards, conical,	292
294	
297	

<i>Hydraulic</i> machinery,	N° 2
<i>Hydraulic</i> ram, <i>Montgolfier's</i> ,	3
<i>Hydraulics</i> ,	1 & 1
<i>Hydrodynamics</i> ,	
<i>Hydrometer</i> invented by <i>Hypathia</i> , <i>Fahrenheit's</i> <i>Jones's</i> , <i>Dicus's</i> , <i>Quin's</i> , <i>Nicholson's</i> , <i>Deparcieux's</i> , <i>Wilson's</i> , theorem for it with weights, with an engraved scale,	1 & 1
<i>Hydrostatics</i> ,	1 & 1
principles of, discovered by <i>Archimedes</i> , applied to experiments by <i>Ghetaldus</i> ,	1
<i>Hydrostatic</i> paradox, machine for illustrating it, bellows, press, <i>Bramah's</i> ,	3
<i>Hypathia</i> invents the hydrometer,	0

I

<i>Jets</i> , theory of vertical, oblique, experiments on,	161, 10
<i>Jones's</i> hydrometer,	196, 2
<i>Imperfect</i> fluids, what,	10

L

<i>Lagrange</i> on the oscillation of waves,	2
<i>Lambert</i> on overshot wheels, on breast wheels,	28
<i>Laplace</i> on capillary attraction,	11
<i>Levelling</i> , foundation of,	3
<i>Lifting</i> pump,	31

M

<i>Machine</i> , hair-rope, <i>Whitehurst's</i> , driven by the reaction of water, <i>Zurich</i> ,	333, 8
<i>Machinery</i> , hydraulic,	2
<i>Maclaurin</i> discusses the motion of fluids,	2
<i>Mariotte's</i> experiments on the motion of fluids,	1
<i>Mercury</i> descends in capillary tubes, cause of this,	1
<i>Michelotti</i> makes experiments on the motion of water,	3
<i>Mill</i> , <i>Barker's</i> ,	3
<i>Waring's</i> rules for constructing it,	3
<i>Milwrights</i> tables, method of constructing them,	285, 2
<i>Montgolfier's</i> hydraulic ram,	31

Morcom

Index.

Morveau's experiments on capillary attraction, N^o 131

N

Newsham's fire-engine, 323

Newton, Sir Isaac, his discoveries in hydraulics, 12

on the oscillation of waves, 13 & 254

Nicholson's hydrometer, 107

Noble's pump, 316

Noria, 4-

O

Oscillation of waves considered by

Newton, 13 & 254

by Flaugergues, 20 & 254

by Lagrange, 21 & 254

of fluids, 250

Overshot wheels, 257

how to compute the momentum of the loaded arch, 258

on the diameter of, 259

on the proper velocity of, 260

according to Deparcieux, 261

Smeaton, 263

Bossut, 264

A. Euler's researches on, 267

Lambert's researches on, table for, ib.

P

Paradox, hydrostatic, 44

Parent's mill. See *Barker's* mill.

Pascal discovers the pressure of the atmosphere, 8

writes on the equilibrium of fluids, ib.

his experiment to shew the gravitation of fluids, 55

Percussion, centre of, 48

Perfect fluids, what, 27

Persian wheel, 331

Pipes, conduit, pressure exerted on them

by the included water, 168

experiments on this subject, 213

Poleni, marquis of, his experiments on the motion of fluids, 14

Pressure, centre of, 47

Pump, Ctesibius's, 309

sucking, 310

forcing, 313

lifting, 314

De la Hire's, 315

Noble's, 316

Buchanan's, 317

balance, 318

chain, 319

Q

Quin's hydrometer, 106

R

Rain wind, cause of it, 354

Resistance sustained by cylinders, 236, 239

by cones, 239

by globes, 239, 241

HYDRODYNAMICS.

Resistance sustained by hemispheres, N^o 239

plane surfaces, 243 & 250

of fluids, 220

Coulomb's experiments on, 221

Hutton's, 239

Vince's, 245

Rivers, motion of, first attended to in Italy, 10

Guglielmini's theory of, 11

Rumford, Count, on the adhesion of fluids, 133

S

Screw-engine, Archimedes's, 328

Segner's form of Barker's mill, 303

Smeaton on overshot wheels, 259, 263

Smeaton's experiments on undershot wheels, 286

Specific gravity defined, 70

gravities of bodies, how to determine, 92

gravity of solids, how to find, 95

of powders, 97

of fluids, 98

gravities, extensive table of, 111

Sucking pump, 310

Syphon, invented by Hiero, description of, 54

T

Table of the altitudes of different fluids in capillary tubes by Martin, 119

of the quantities of water discharged by different orifices, 172

of the quantities of water discharged according to theory and experiment, 174

of the results of Eytelwein's experiments, 178

of the quantities of water discharged by cylindrical tubes, 182, 183

of the quantities discharged by cylindrical tubes, according to theory and experiment, 185

of the quantities discharged by conical tubes, 187

of the quantities discharged by orifices of various forms, 188

shewing the time in which vessels are partly exhausted, 194, 195

shewing the altitudes, &c. of jets, 196

of the quantities of water discharged by conduit pipes, 204—211

shewing the pressure exerted upon pipes, 213

of the velocity of water in canals, 214, 215

shewing the resistance of hemispheres, cones, globes, and cylinders, 239

shewing the resistance of globes, 241

shewing the resistance of plane surfaces, 243, 245

Table of the maximum effect of overshot wheels, N^o 260, 264

for overshot wheels, 267

for breast wheels, 269

for undershot wheels, 285, 286

for machines driven by the reaction of water, 304

Torricelli discovers an important proposition in hydraulics, 7

Torsion, the principle of, employed by Coulomb to determine the resistance of fluids, 221

Tubes, cylindrical, discharge more water than simple orifices, 180

conical, Poleni's experiments with, 187

of various forms, Venturi's experiments with, 188

capillary, how to measure their diameters, 120

U

Undershot wheels, 272

number of their floatboards, 273—275

form of their floatboards, 276

position of their floatboards, 277

velocity of, 279

maximum effect of, according to theory, 280

maximum effect of, according to Smeaton, 281

maximum effect of, according to Bossut, 282

tables for, 285, 286

how to construct them, 284

Smeaton's experiments on, 289

Undulation of waves, 253

Velocity of fluids issuing from orifices, 137

Vena contracta, discovered by Newton, quantity of its contraction according to different authors, 171

Venturi discovers the lateral communication of motion in fluids, 23

Vessels, time in which they are exhausted, 155—177

Vera's hair-rope machine, 320

W

Waring's rules for Barker's mill, 302

Water blowing machine, 351

clocks, theory and construction of, 159

clocks move faster in summer than winter, 218

fluidity of, increased by electricity and by heat, 121

running, method of measuring its velocity, 288

instrument for, ib.

Water wheels,
Waves, undulation of,
oscillation of,
Wheels, overshot,
breast,
undershot,
Besant's,

N° 256	Wheels driven by the reaction of	N° 299
253	water,	292
13, 20, 21	horizontal,	298
257	conical,	
268	driven by the impulse, weight,	307
272	and reaction of water,	331
297	Persian,	

Whitehurst's machine,
Wilson's hydrometer,
Wind, rain, cause of it,
Z
Zimmerman on the compressibility of
fluids,
Zurich machine,

END OF THE TENTH VOLUME.

DIRECTIONS FOR PLACING THE PLATES, &c. OF VOL. X.

PART I.

GRAMMATICAL TABLE, to face	page 8
Plate CXLVIII. CXLIX.	188
CCL.	300
CCLI.—CCLIII.	364

PART II.

CCLIV.—CCLX.	426
HISTORICAL CHART,	546
Plate CCLXI.	572
CCLXII.	662
CCLXIII.—CCLXXV.	792

Fig. 1.

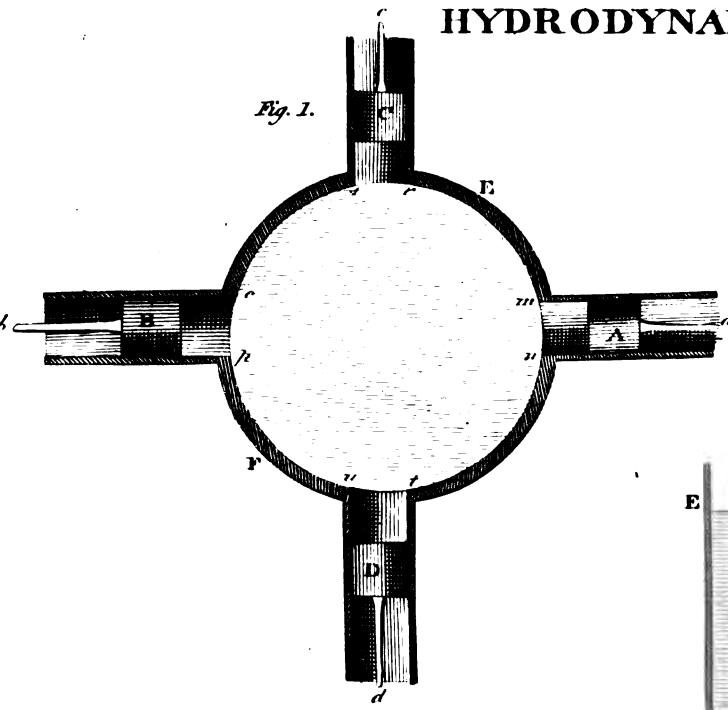

Fig. 2.

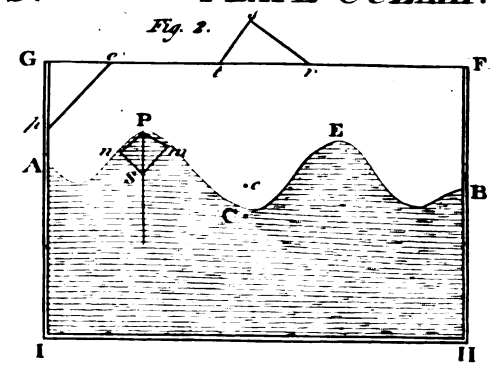

Fig. 4.

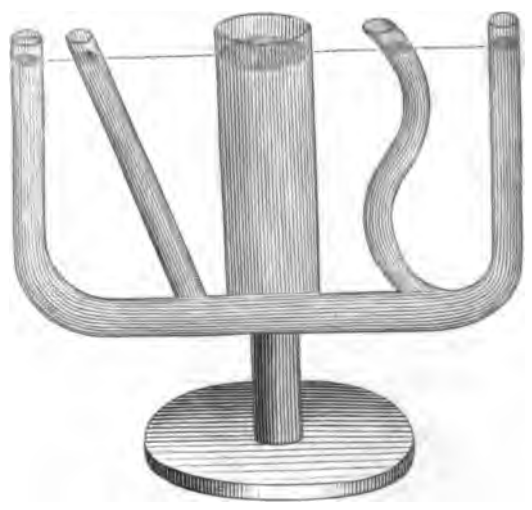

Fig. 3.

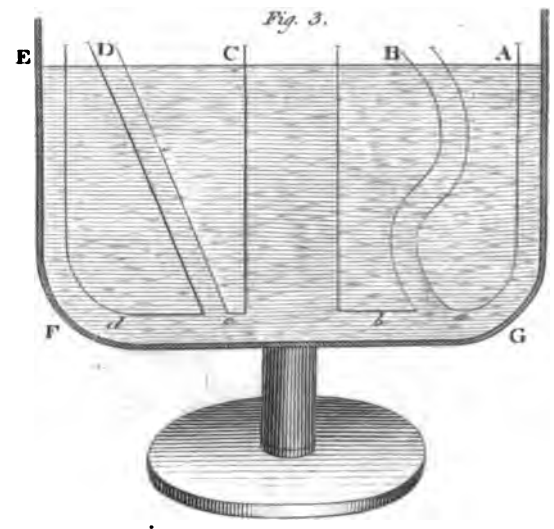

Fig. 5.

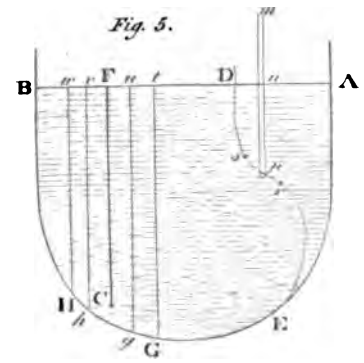

Fig. 6.

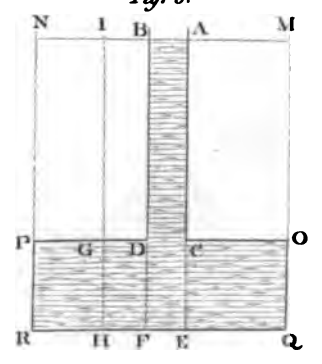

Fig. 7.

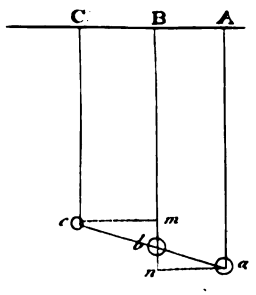

Fig. 8.

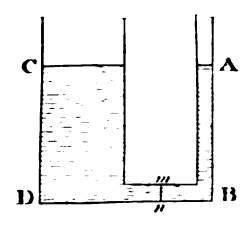
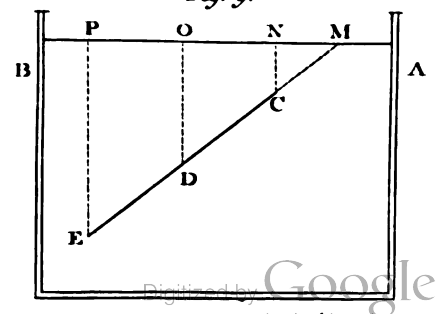
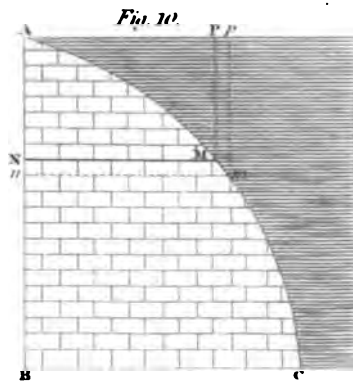
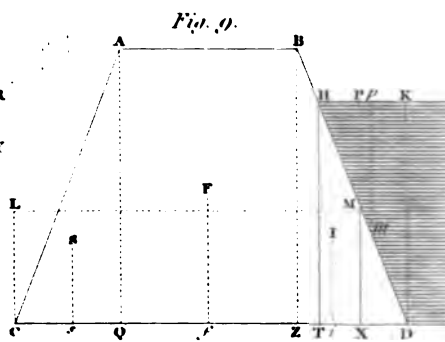
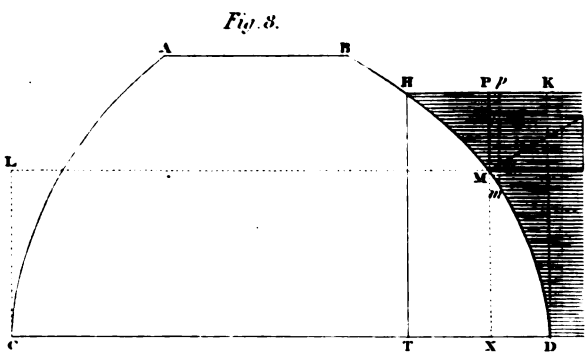
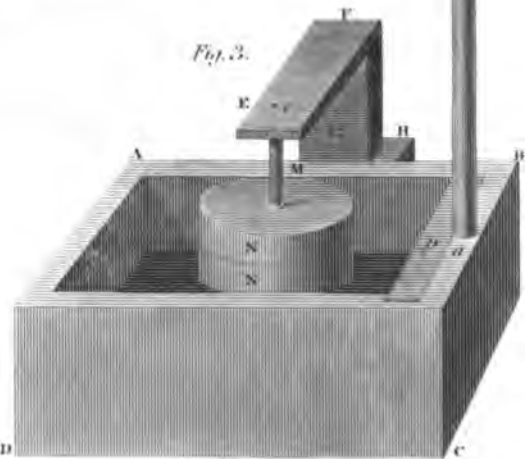
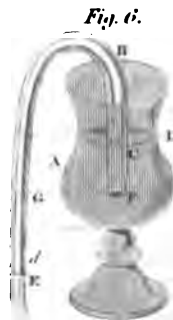
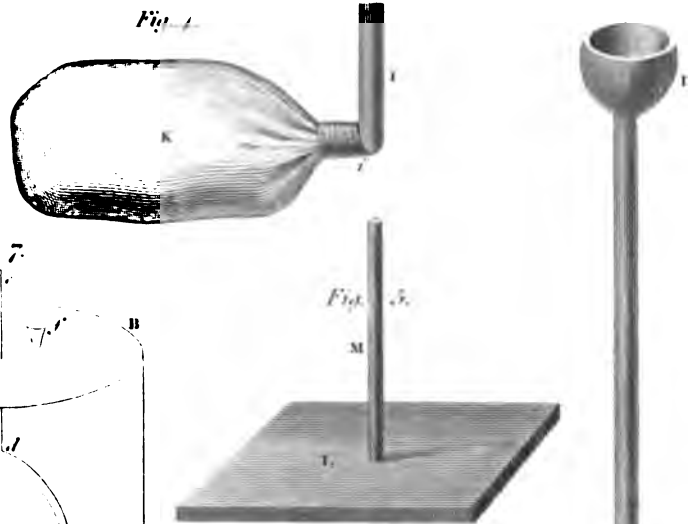
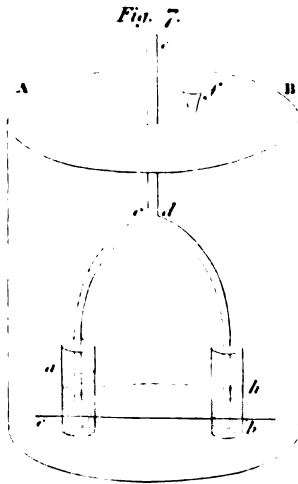
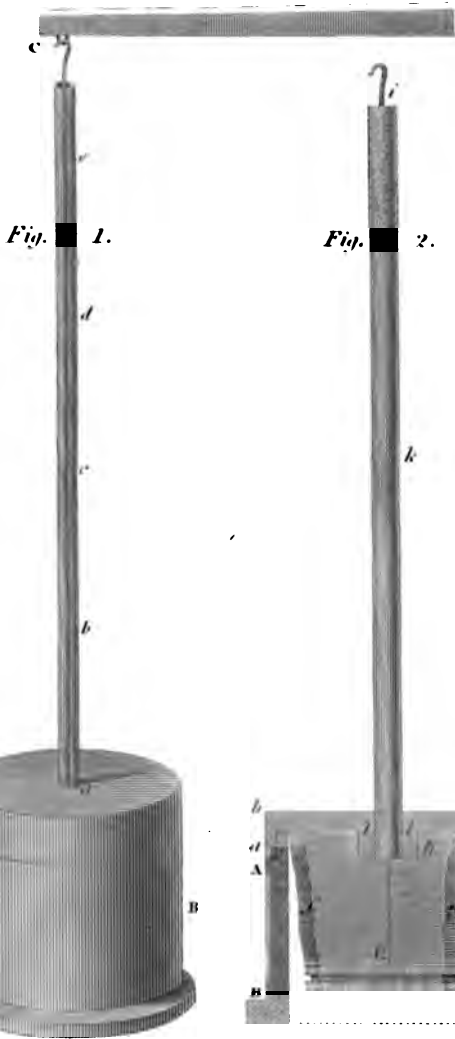
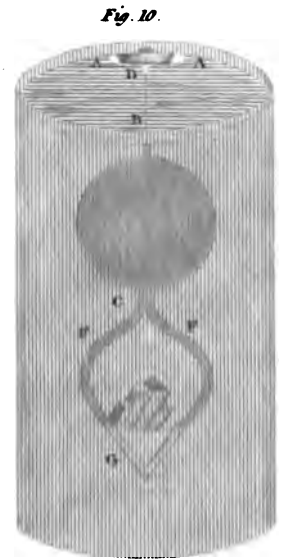
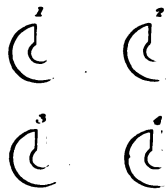
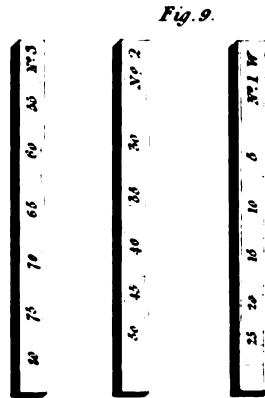
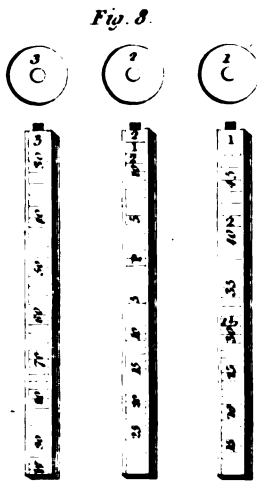
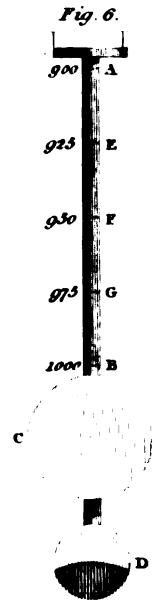
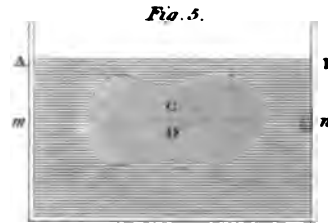
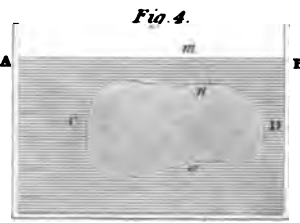
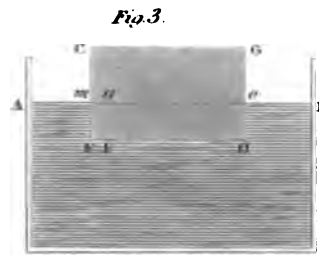
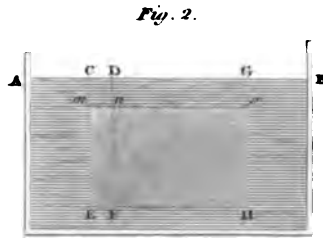
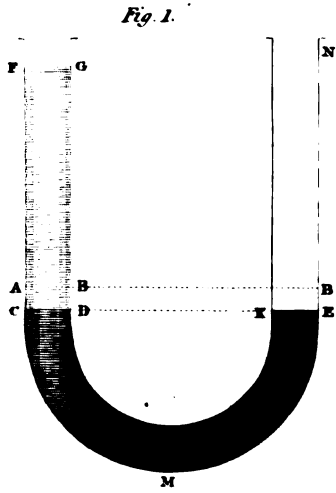

Fig. 9.







Eng^d by W & D Linnell Edin^g

Fig. 1.



Fig. 2.



Fig. 3.

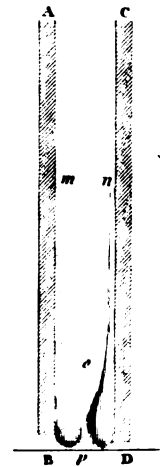

Fig. 4.

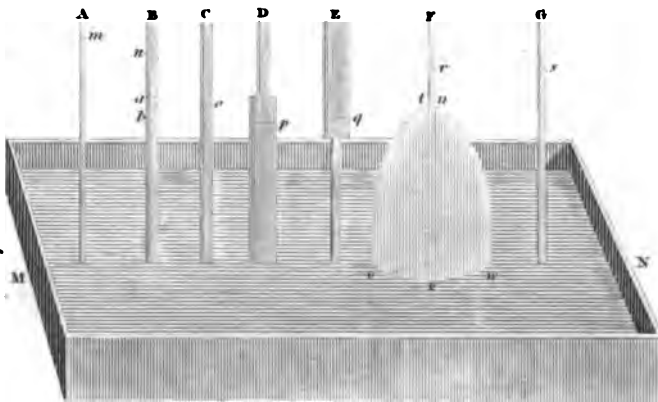

Fig. 5.

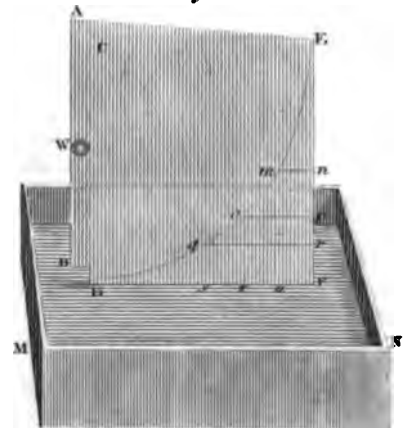

Fig. 6.

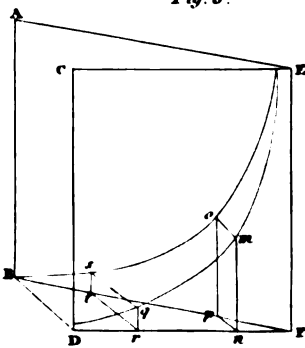

Fig. 7.

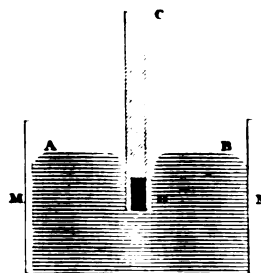

Fig. 8.



Fig. 9.



Fig. 10.

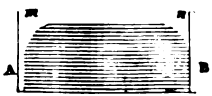

Fig. 1.

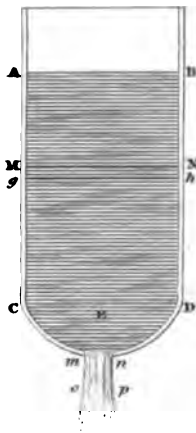

Fig. 2.



Fig. 3.

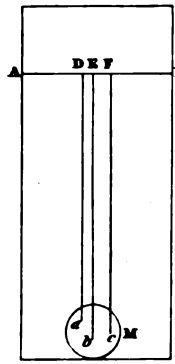

Fig. 4.

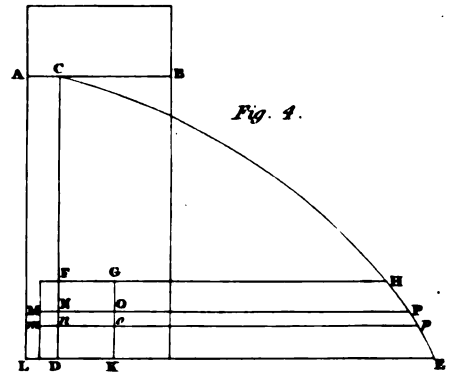

Fig. 5.

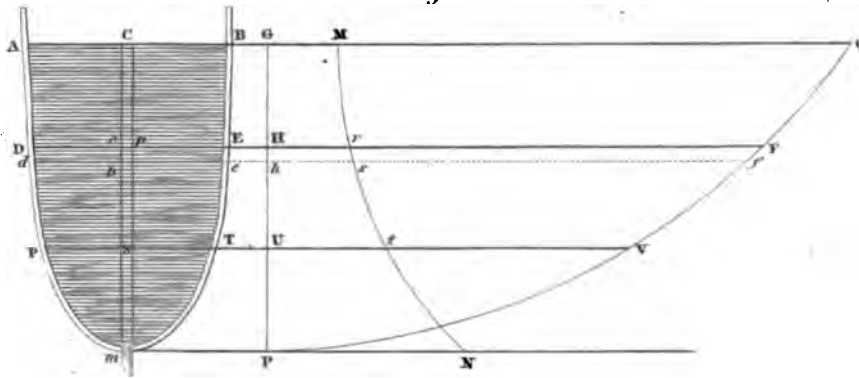

Fig. 7.

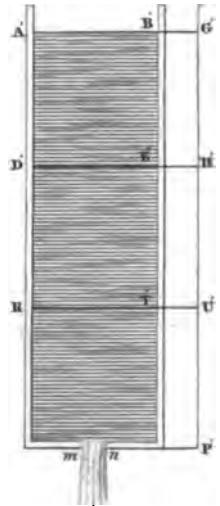

Fig. 6.

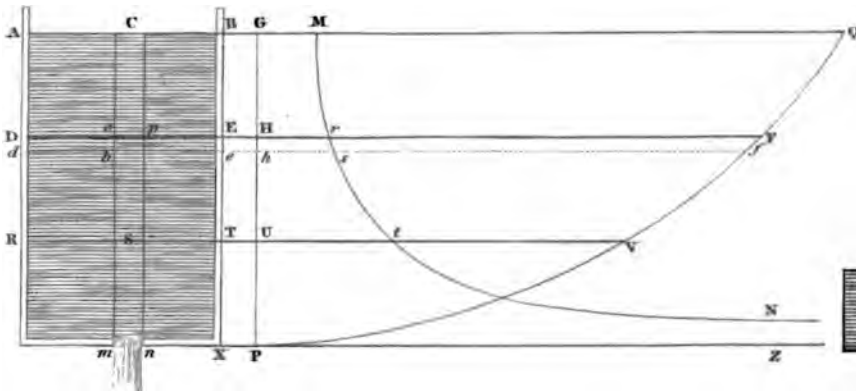

Fig. 9.

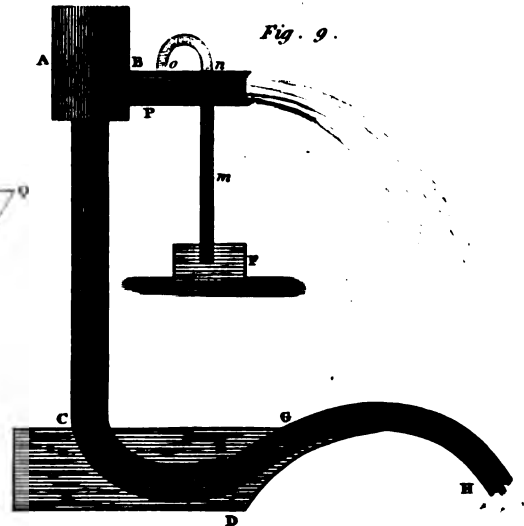

Fig. 1.

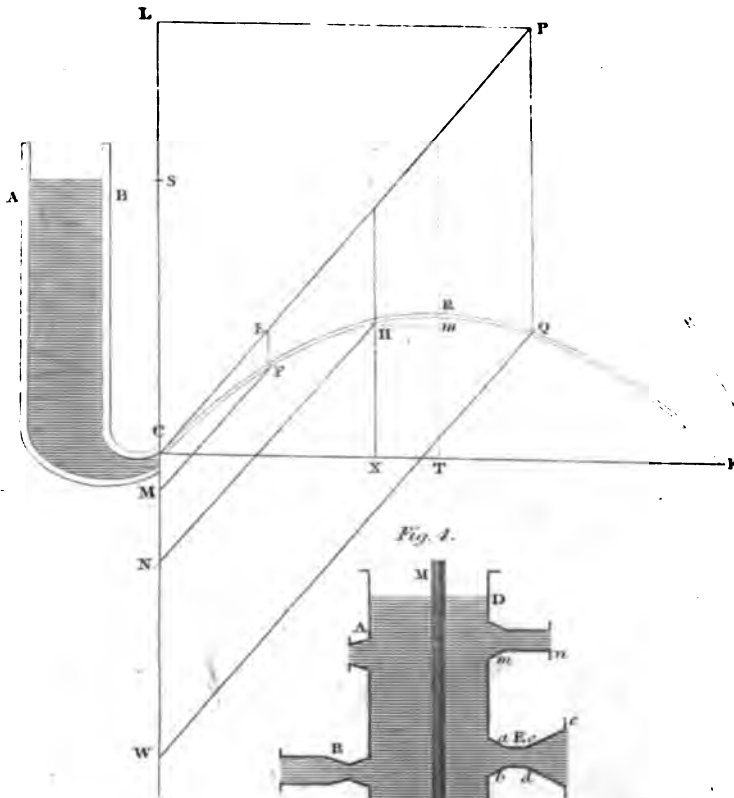

Fig. 2.

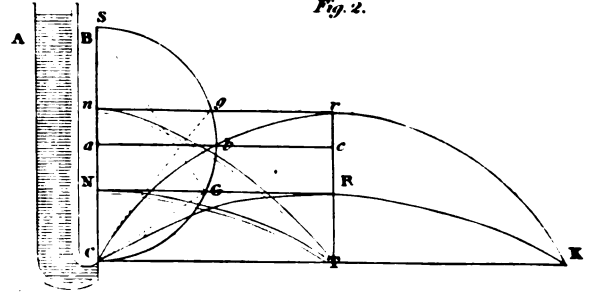

Fig. 3.

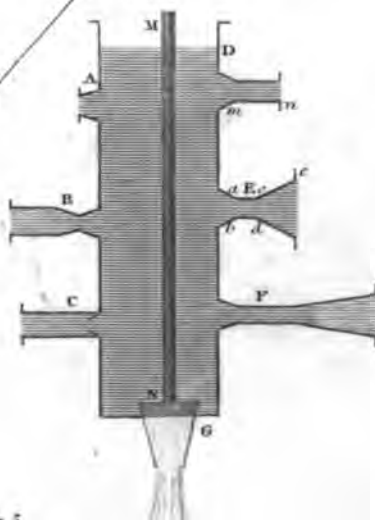

Fig. 4.

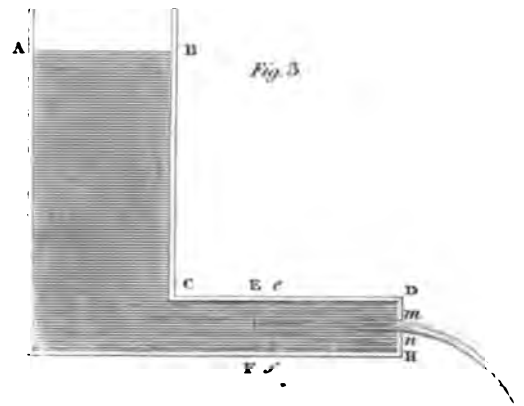

Fig. 5.



Fig. 6.

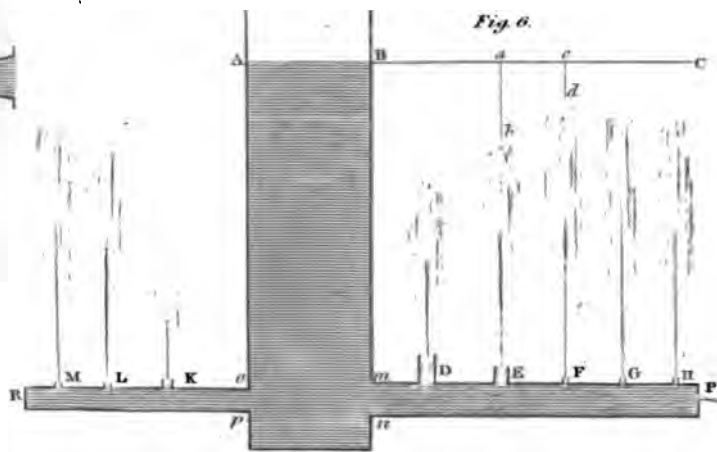

Fig. 7.

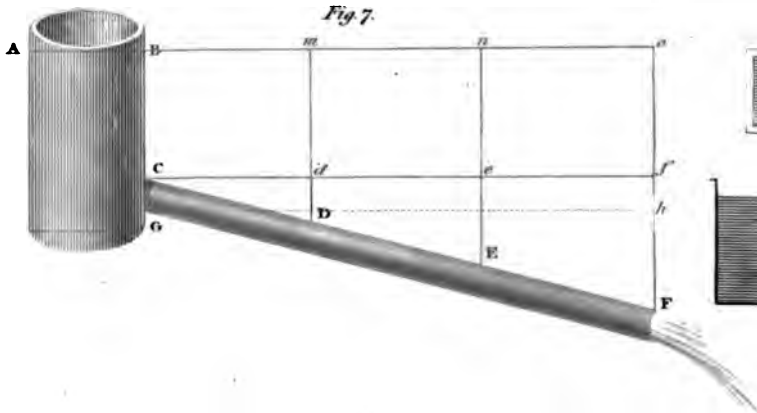

Fig. 8.

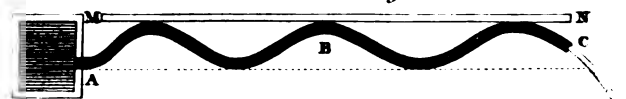

Fig. 9.

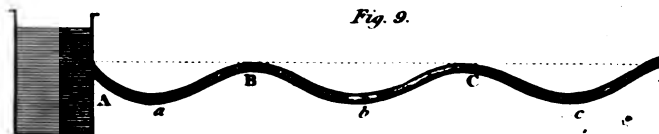

Fig. 1.



Fig. 2.

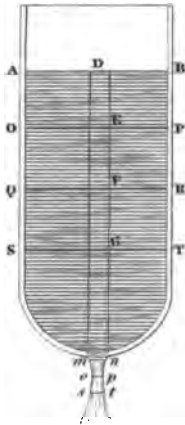

Fig. 3.

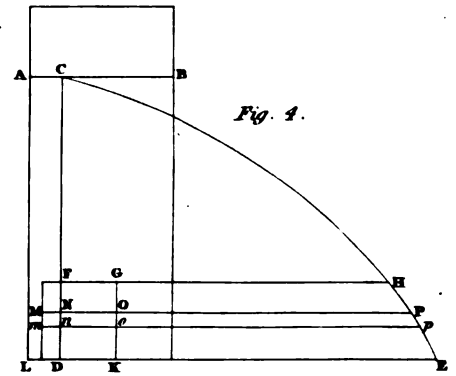
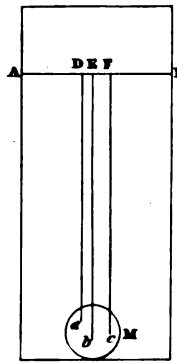

Fig. 4.

Fig. 5.

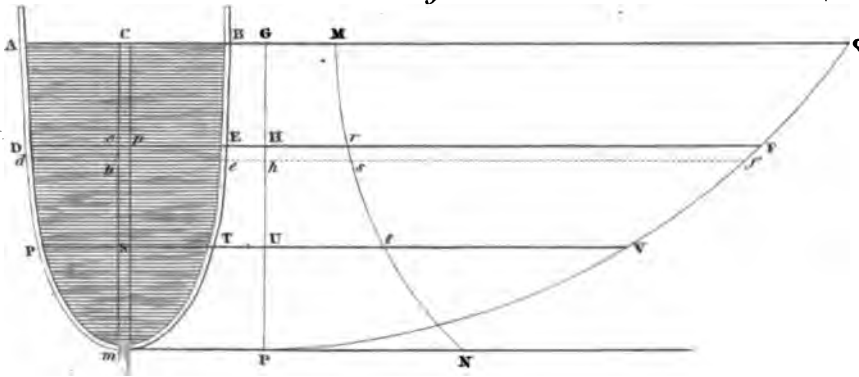

Fig. 7.

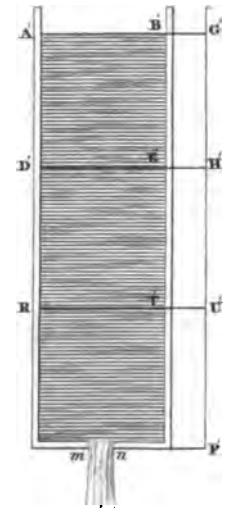

Fig. 6.

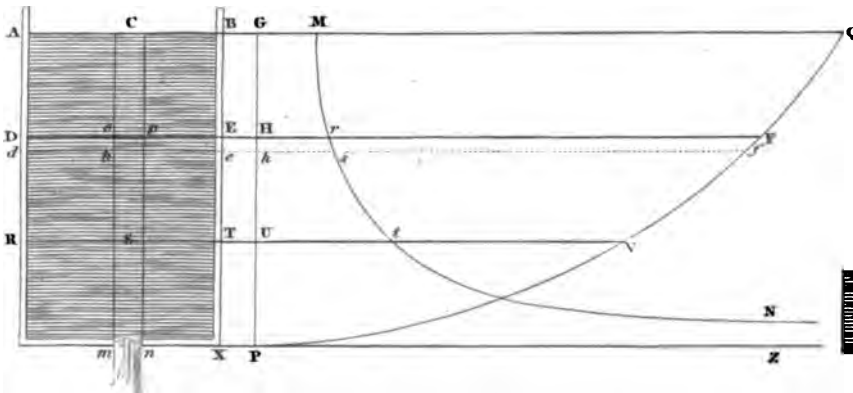

Fig. 9.

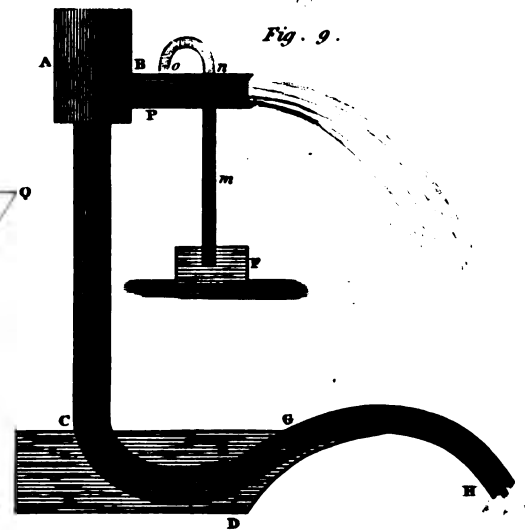

Fig. 1.

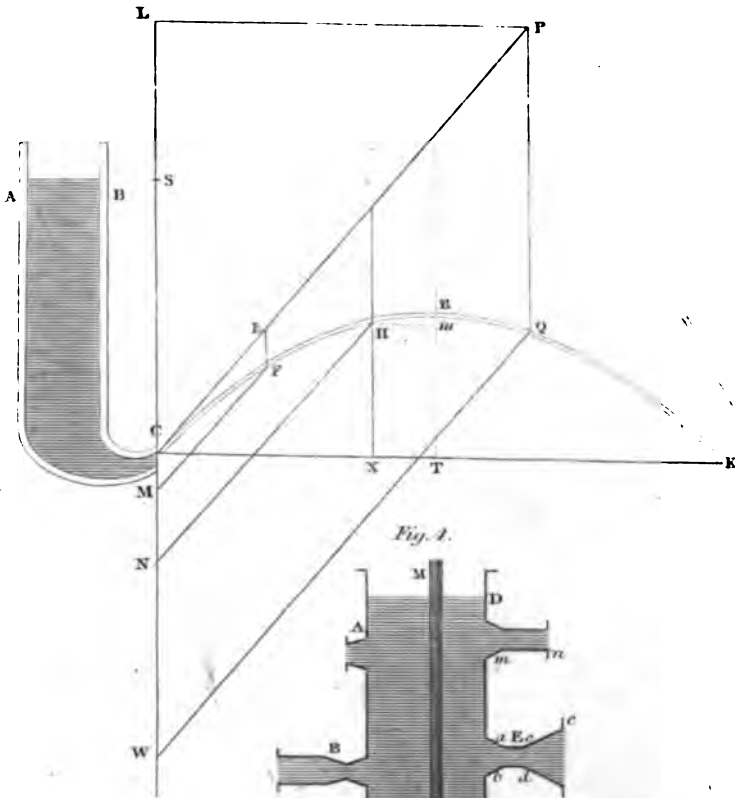

Fig. 2.

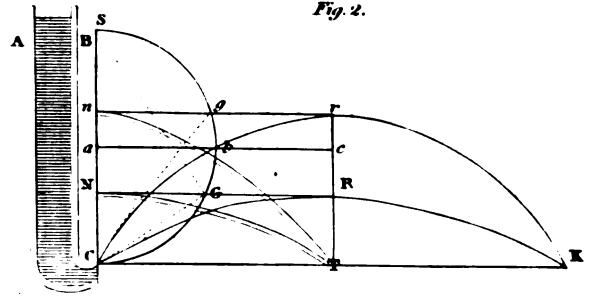

Fig. 4.

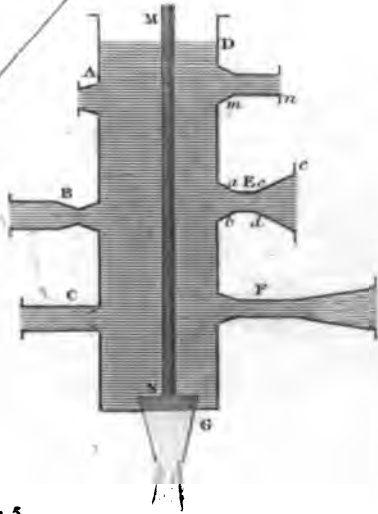

Fig. 3.

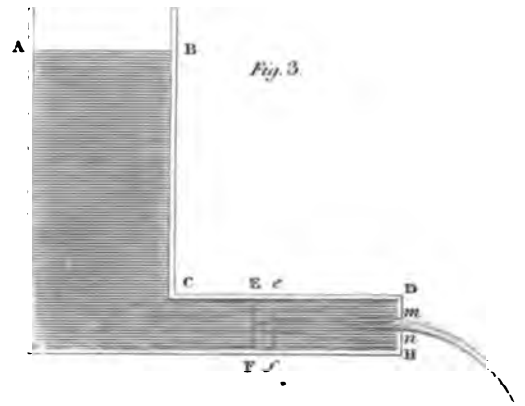

Fig. 5.

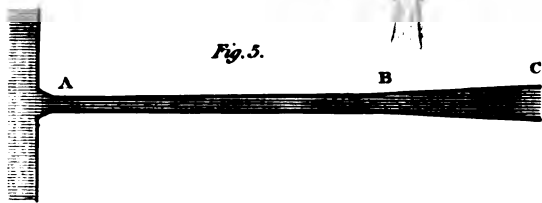

Fig. 6.

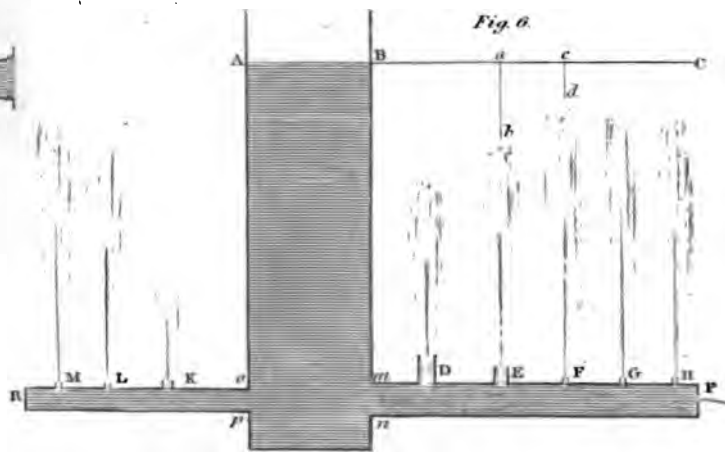

Fig. 7.

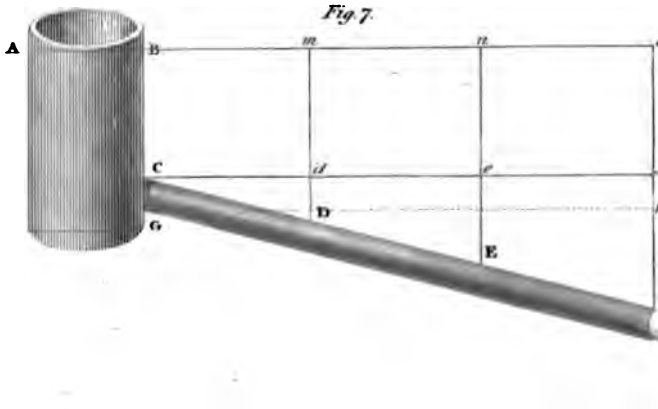

Fig. 8.

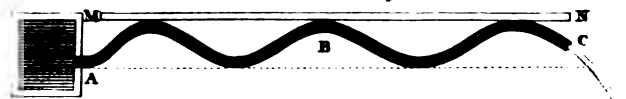
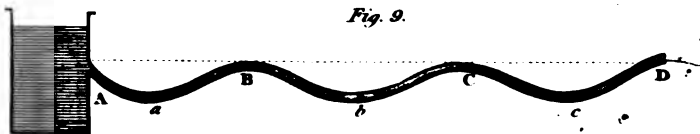
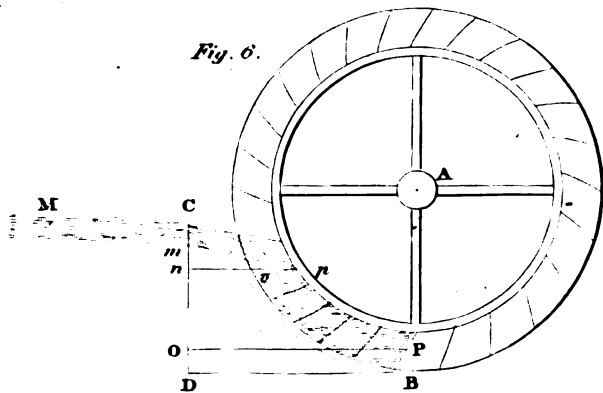
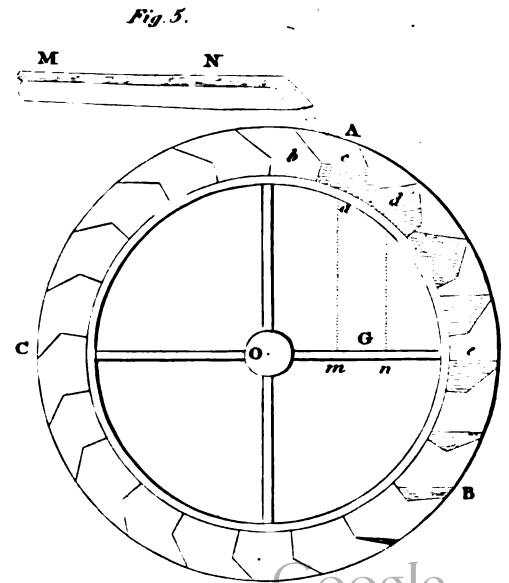
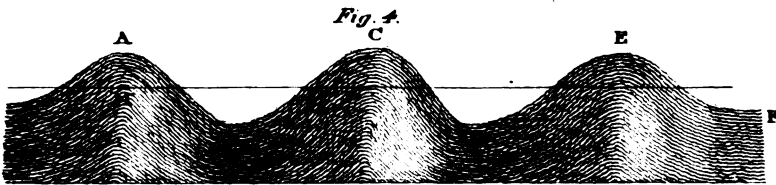
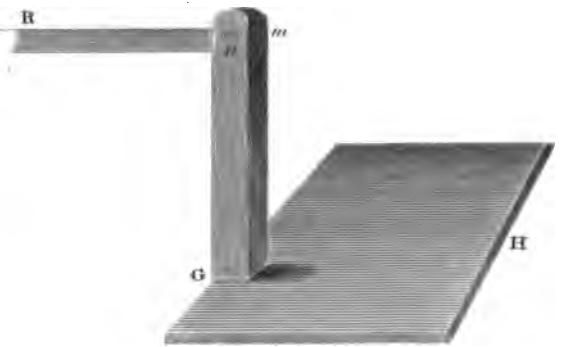
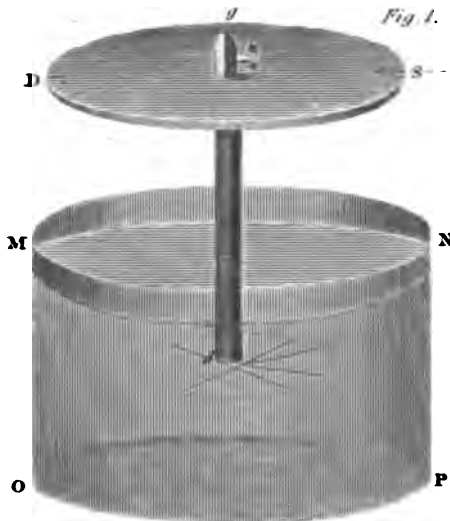
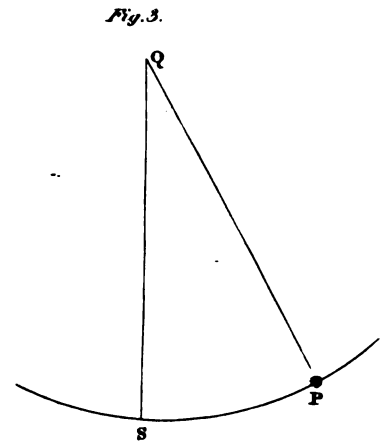
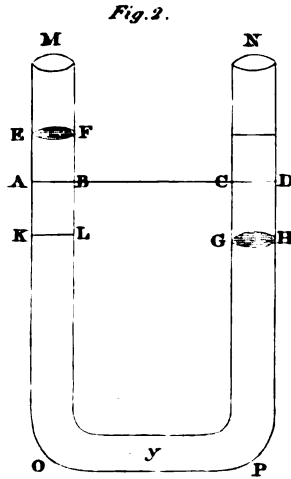

Fig. 9.





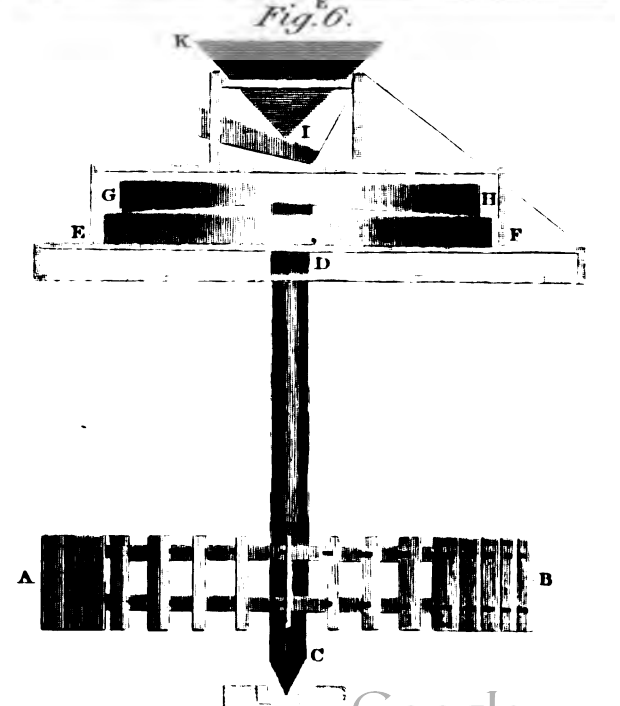
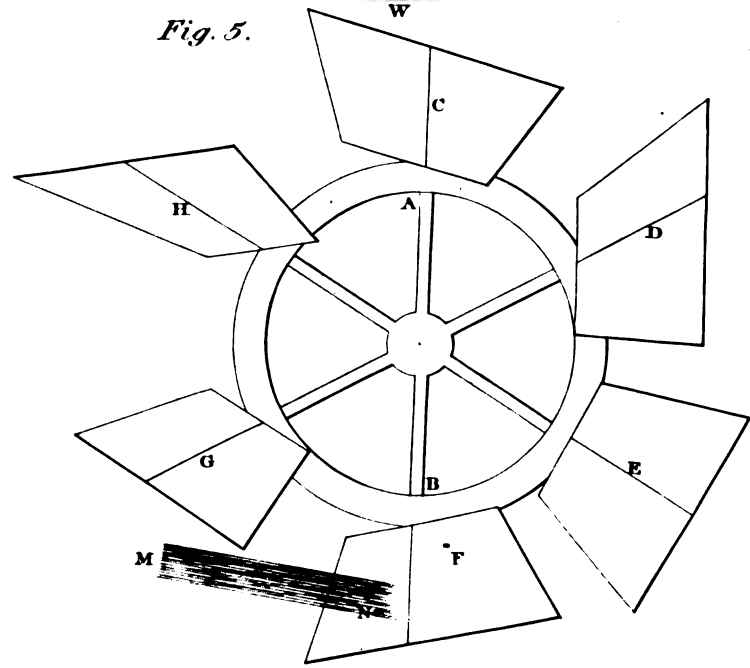
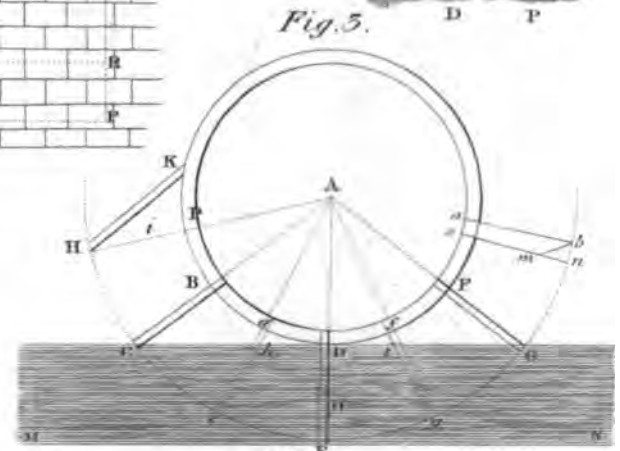
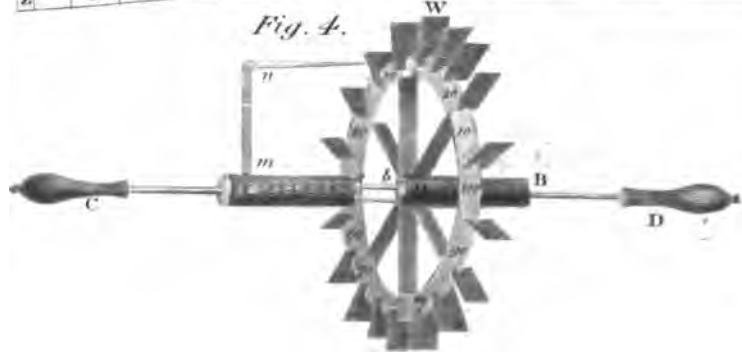
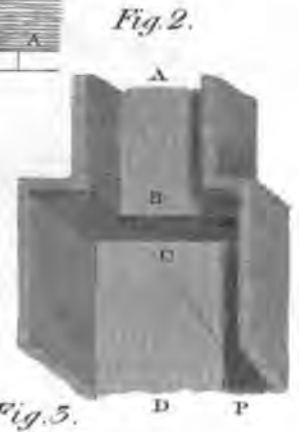
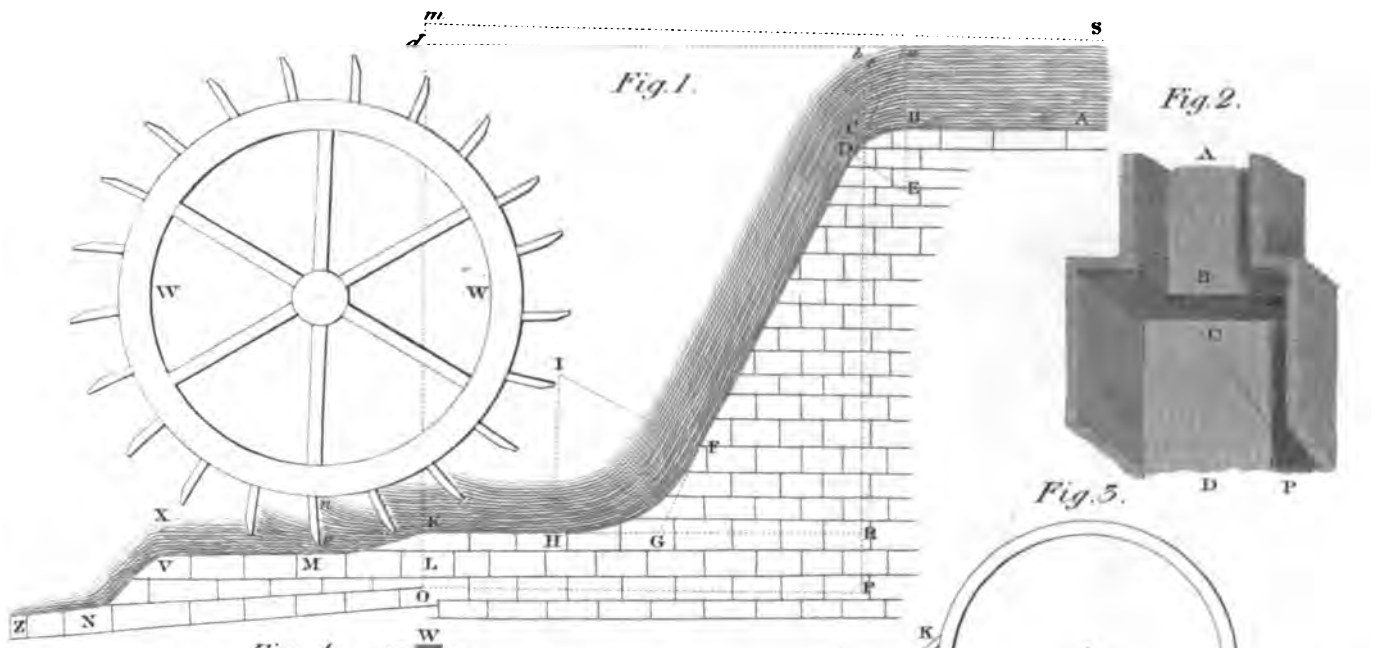

Fig. 2.

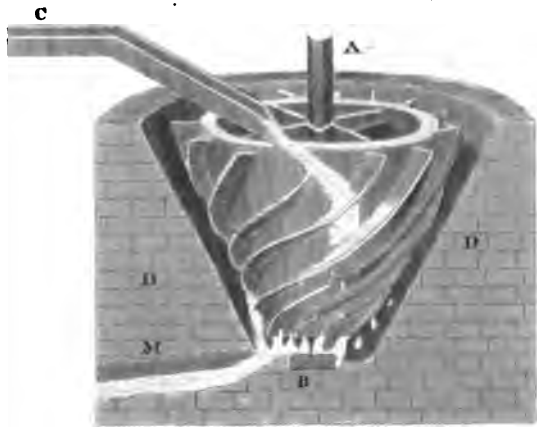

Fig. 1.

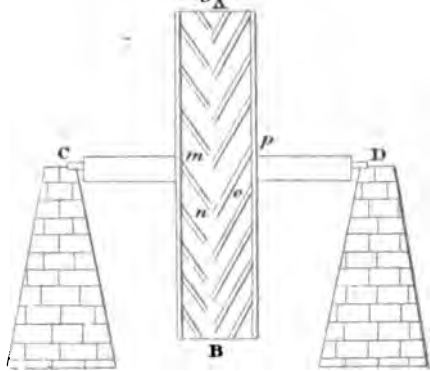

Fig. 4.

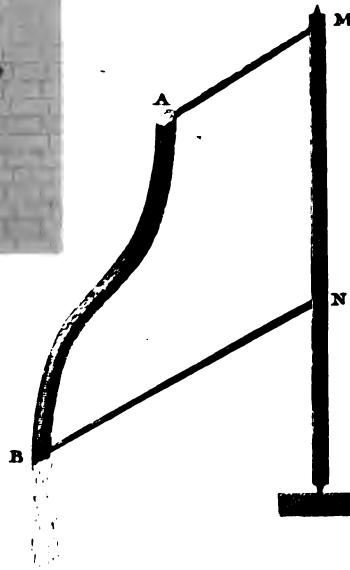

Fig. 3.

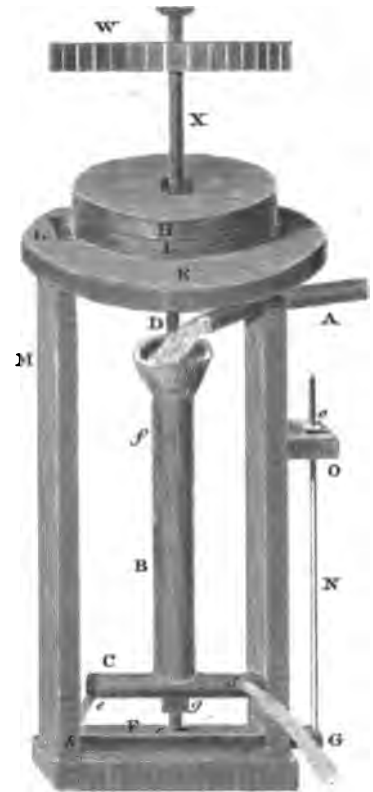

Fig. 5.

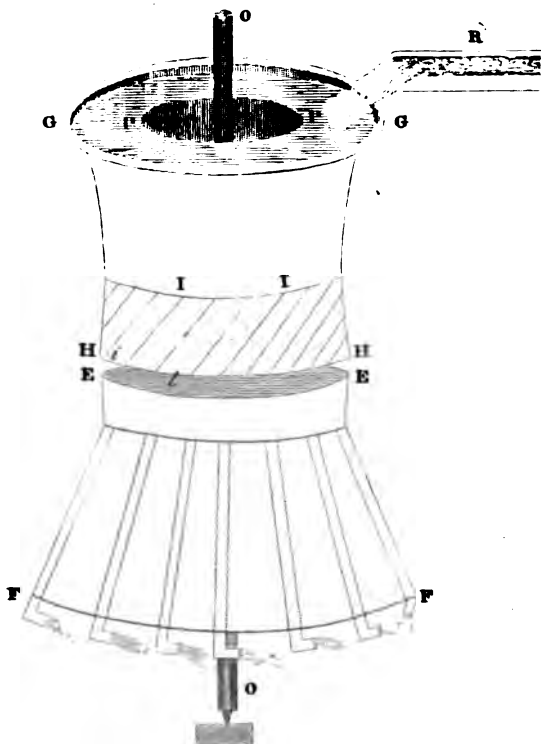
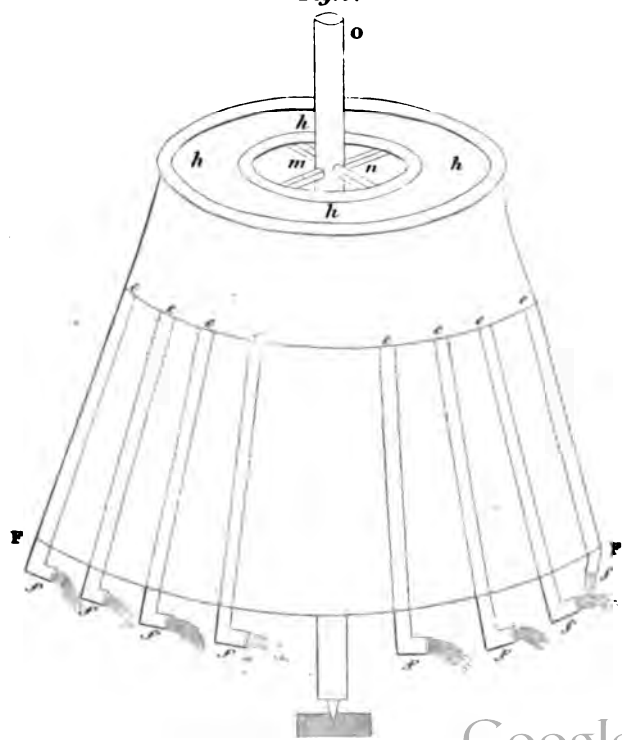

Fig. 6.



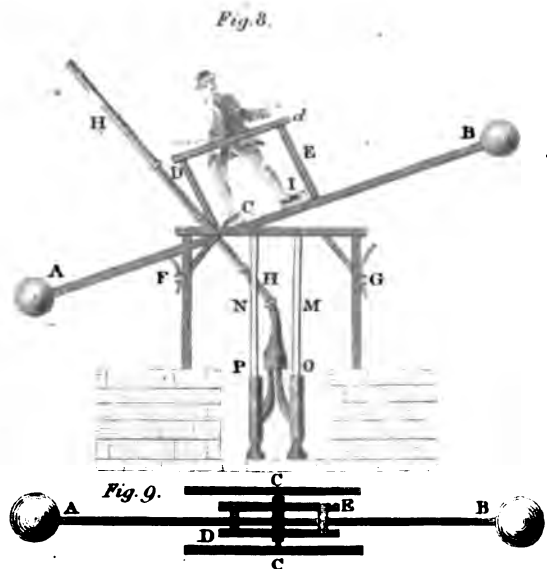
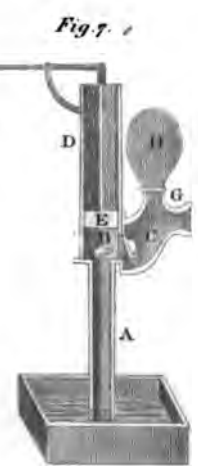
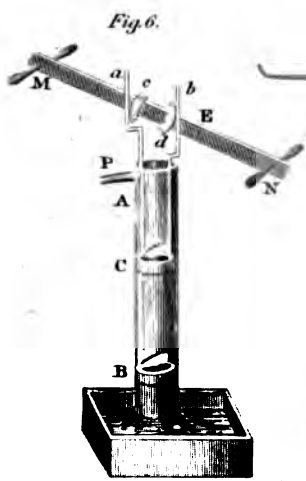
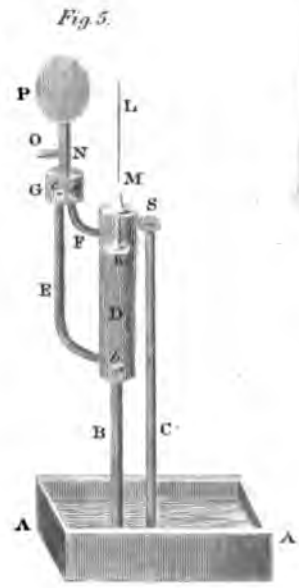
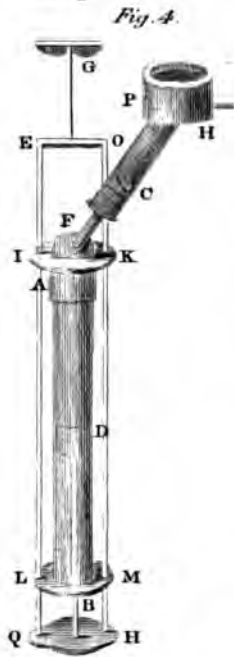
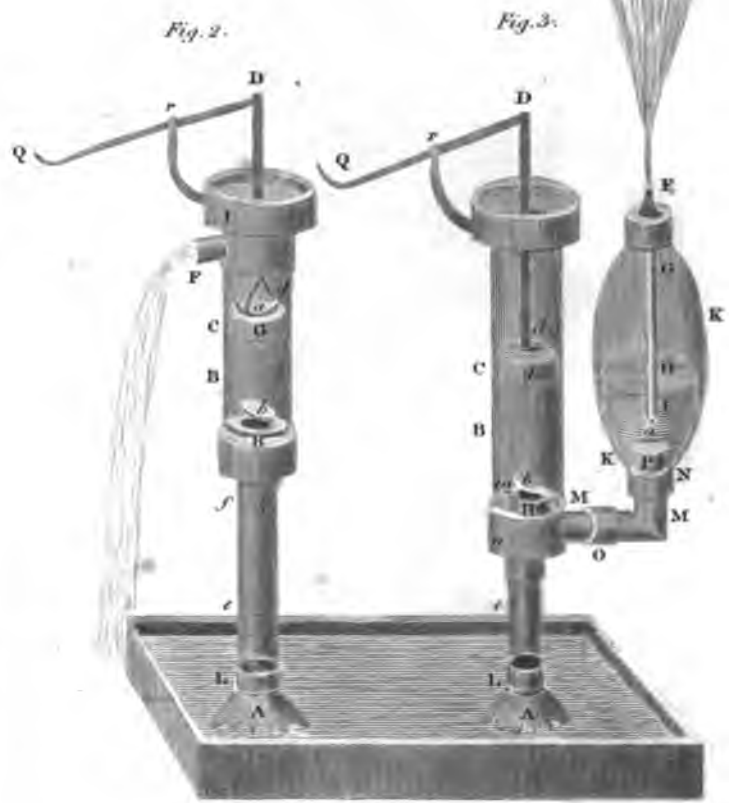
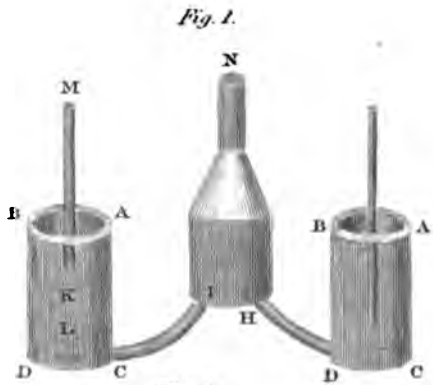

Fig. 1.

HYDRODYNAMICS

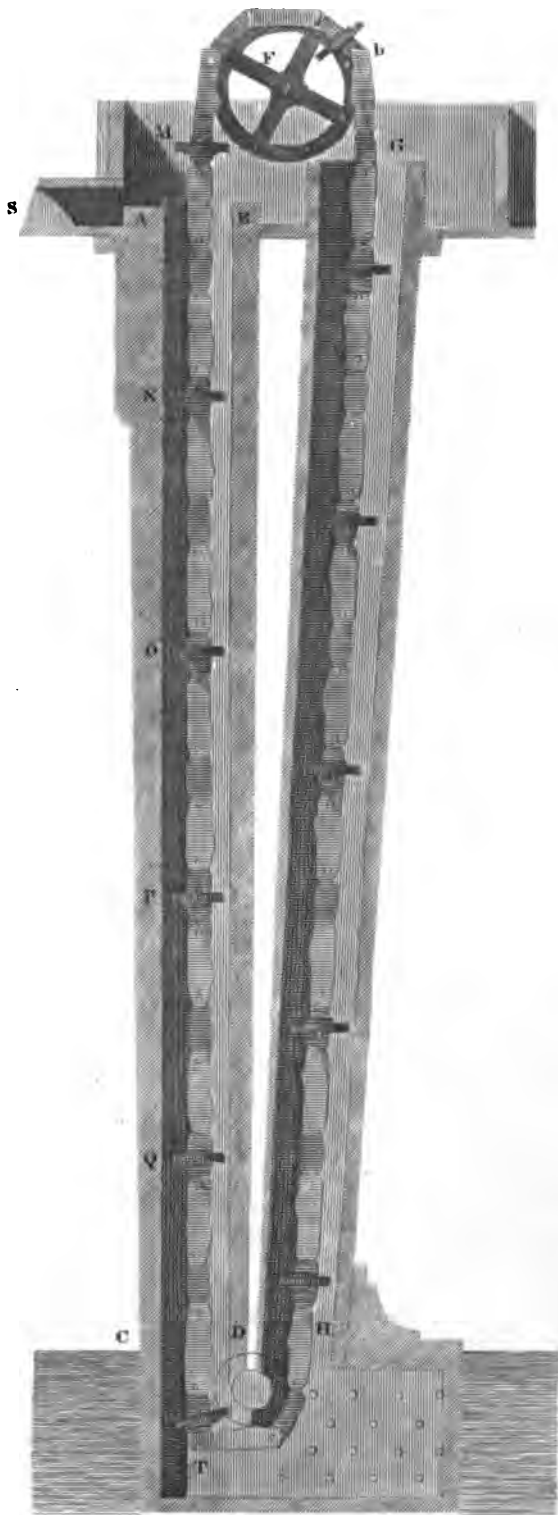

Fig. 2.



Fig. 4.

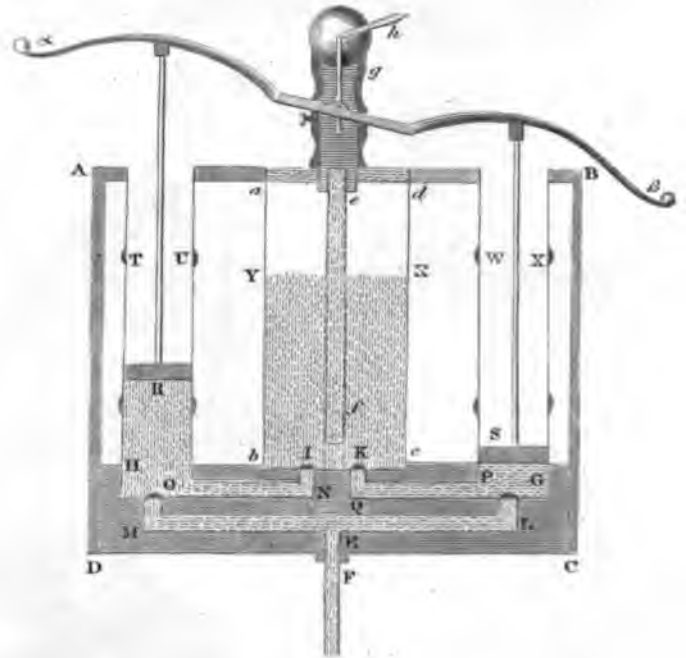

Fig. 3.



Fig. 1.

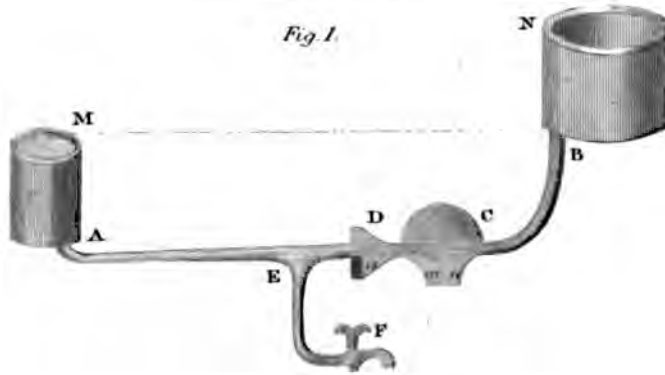

Fig. 2.

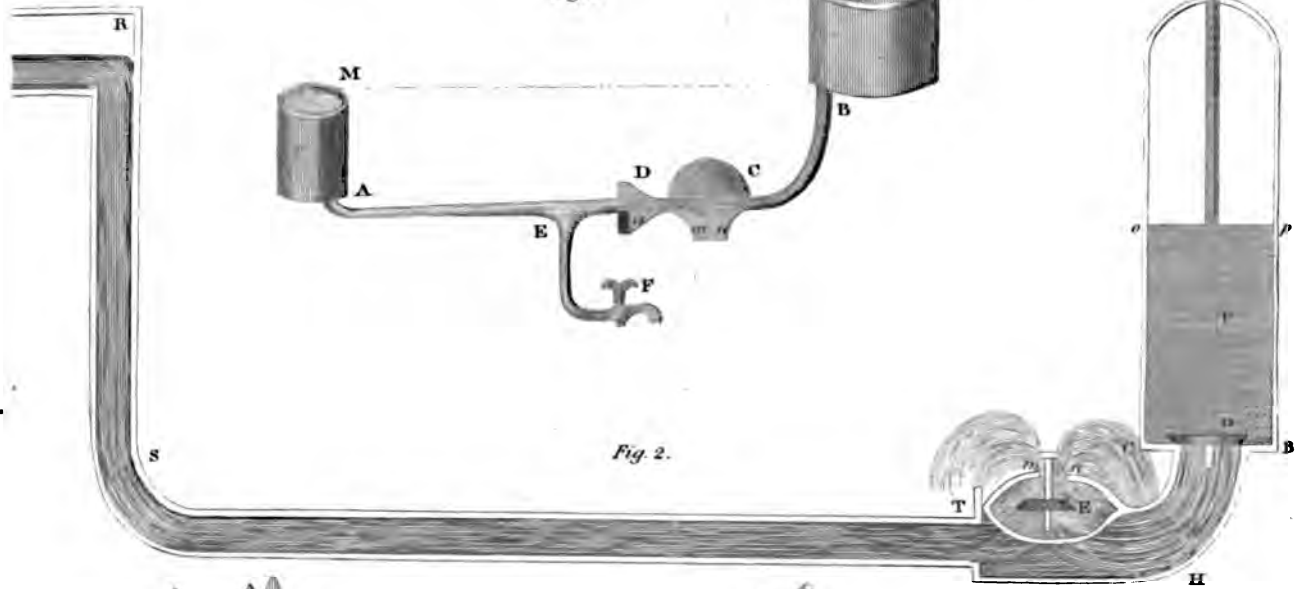

Fig. 3.

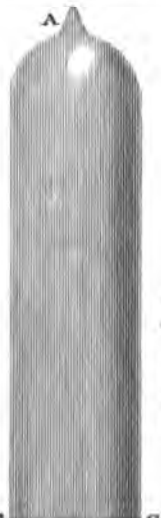

Fig. 4.

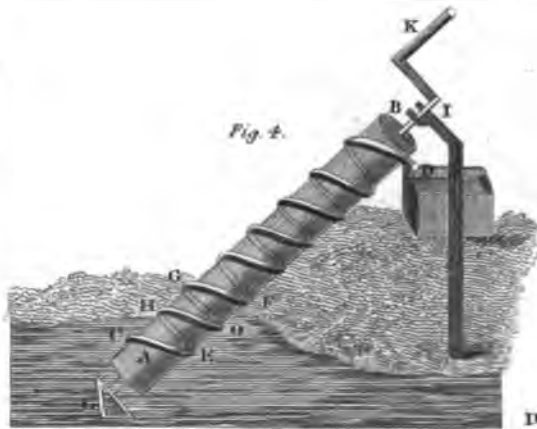

Fig. 5.

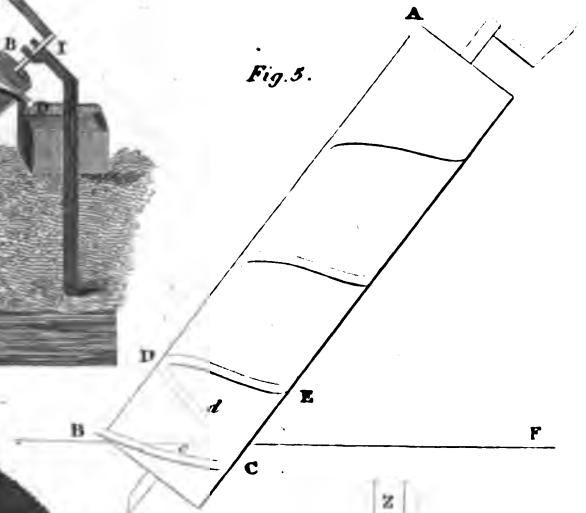

Fig. 6.

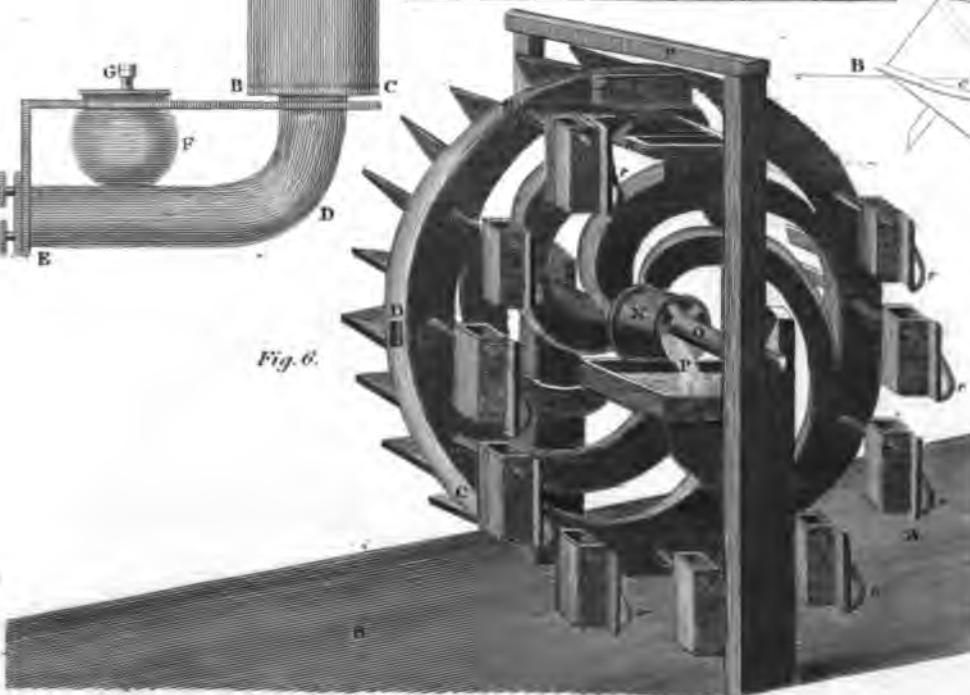

Fig. 7.

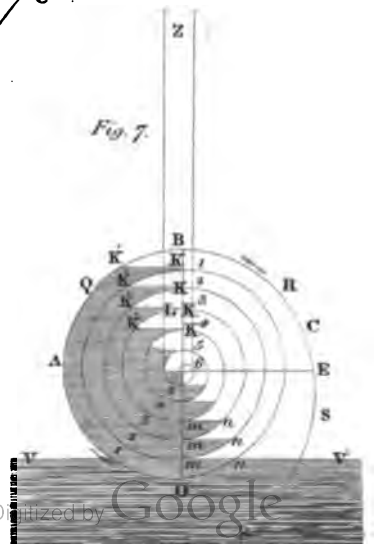

Fig. 1.

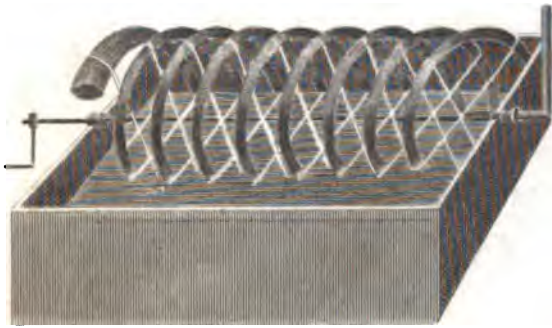

Fig. 2.

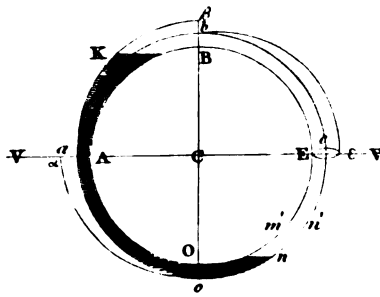

Fig. 3.

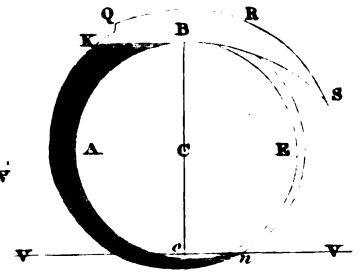

Fig. 4.



Fig. 6.

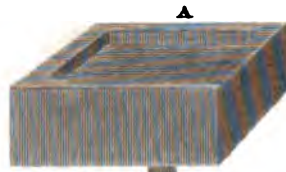
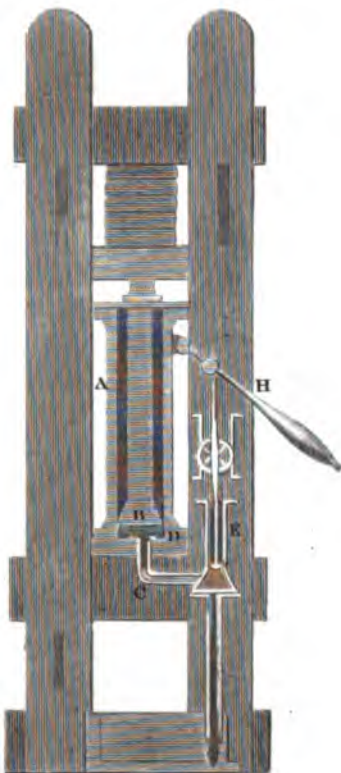

Fig. 5.

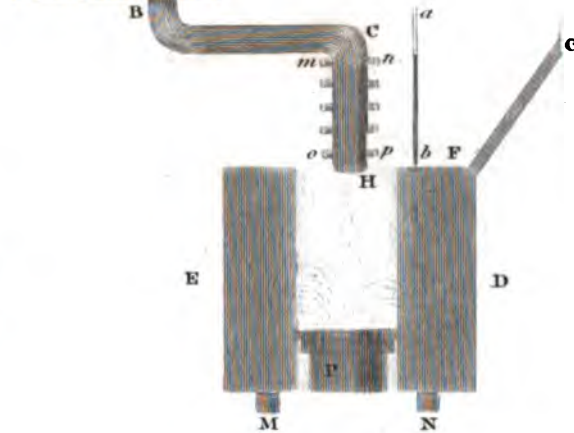

Fig. 3.

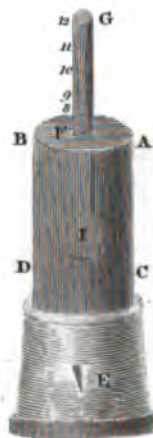

Fig. 7.

